

Draft **EN 300 497-4** V0.3.0 (1998-08)

European Standard (Telecommunications series)

**Digital Enhanced Cordless Telecommunications (DECT);
Common Interface (CI) Test Case Library (TCL);
Part 4: Test Suite Structure and Test Purposes (TSS&TP) -
Data Link Control (DLC) layer**



Reference

REN/DECT-040131-4 (4lp00100.PDF)

Keywords

DECT, testing, TSS&TP, layer 2

ETSI

Postal address

F-06921 Sophia Antipolis Cedex - FRANCE

Office address

650 Route des Lucioles - Sophia Antipolis
Valbonne - FRANCE
Tel.: +33 4 92 94 42 00 Fax: +33 4 93 65 47 16
Siret N° 348 623 562 00017 - NAF 742 C
Association à but non lucratif enregistrée à la
Sous-Préfecture de Grasse (06) N° 7803/88

Internet

secretariat@etsi.fr
<http://www.etsi.fr>
<http://www.etsi.org>

Copyright Notification

No part may be reproduced except as authorized by written permission.
The copyright and the foregoing restriction extend to reproduction in all media.

© European Telecommunications Standards Institute 1998.
All rights reserved.

Contents

Intellectual Property Rights.....	5
Foreword	5
1 Scope.....	6
2 References.....	6
3 Definitions and abbreviations	7
3.1 Definitions	7
3.2 Abbreviations.....	7
4 Test Suite Structure (TSS).....	8
4.1 Overview.....	8
4.2 TSS	9
4.3 Test groups	9
4.3.1 Protocol groups	10
4.3.1.1 C-plane	10
4.3.1.2 U-plane	10
4.3.2 Main test groups.....	10
4.3.2.1 Capability (CA) tests	10
4.3.2.2 Valid Behaviour (BV) tests	10
4.3.2.3 Inopportune Behaviour (BO) tests.....	10
4.3.2.4 Invalid Behaviour (BI) tests.....	10
5 Test Purposes (TP).....	10
5.1 Introduction.....	10
5.1.1 TP definition conventions	10
5.1.2 TP naming conventions	11
5.1.3 Sources of TP definitions	11
5.2 C-plane.....	12
5.2.1 LAPC Class U service.....	12
5.2.1.1 CA tests	12
5.2.1.2 BV tests	12
5.2.1.3 BI tests.....	13
5.2.1.4 BO tests	13
5.2.2 LAPC Class A service.....	14
5.2.2.1 CA tests	14
5.2.2.2 BV tests	15
5.2.2.3 BI tests.....	16
5.2.2.4 BO tests	17
5.2.3 LAPC Class B service	18
5.2.3.1 CA tests	18
5.2.3.2 BV tests	18
5.2.3.3 BI tests.....	18
5.2.3.4 BO tests	18
5.2.4 Broadcast service (Lb)	18
5.2.4.1 CA tests	18
5.2.4.2 BV tests	18
5.2.4.3 BI tests.....	18
5.2.4.4 BO tests	18
5.3 U-plane	19
5.3.1 Class 0 transmission procedures.....	19
5.3.1.1 CA tests	19
5.3.1.2 BV tests	19
5.3.1.3 BI tests.....	19
5.3.1.4 BO tests	19
5.3.2 Class 1 transmission procedures.....	19
5.3.2.1 CA tests	19

5.3.2.2	BV tests	19
5.3.2.3	BI tests	20
5.3.2.4	BO tests	20
5.3.3	Class 2 transmission procedures.....	20
5.3.3.1	CA tests	20
5.3.3.2	BV tests	20
5.3.3.3	BI tests.....	20
5.3.3.4	BO tests	20
5.3.4	Class 3 transmission procedures.....	20
5.3.4.1	CA tests	20
5.3.4.2	BV tests	20
5.3.4.3	BI tests.....	20
5.3.4.4	BO tests	20
	Bibliography	21
	History	22

Intellectual Property Rights

IPRs essential or potentially essential to the present document may have been declared to ETSI. The information pertaining to these essential IPRs, if any, is publicly available for **ETSI members and non-members**, and can be found in SR 000 314: "*Intellectual Property Rights (IPRs); Essential, or potentially Essential, IPRs notified to ETSI in respect of ETSI standards*", which is available **free of charge** from the ETSI Secretariat. Latest updates are available on the ETSI Web server (<http://www.etsi.fr/ipr> or <http://www.etsi.org/ipr>).

Pursuant to the ETSI IPR Policy, no investigation, including IPR searches, has been carried out by ETSI. No guarantee can be given as to the existence of other IPRs not referenced in SR 000 314 (or the updates on the ETSI Web server) which are, or may be, or may become, essential to the present document.

Foreword

This European Standard (Telecommunications series) has been produced by ETSI Project Digital Enhanced Cordless Telecommunications (DECT), and is now submitted for the Public Enquiry phase of the ETSI standards Two-step Approval Procedure.

The present document is part 4 of a multi-part EN covering the Common Interface (CI) Test Case Library (TCL), as identified below:

- Part 1: "Test Suite Structure (TSS) and Test Purposes (TP) for Medium Access Control (MAC) layer";
- Part 2: "Abstract Test Suite (ATS) for Medium Access Control (MAC) layer - Portable radio Termination (PT)";
- Part 3: "Abstract Test Suite (ATS) for Medium Access Control (MAC) layer - Fixed radio Termination (FT)";
- Part 4: "Test Suite Structure (TSS) and Test Purposes (TP) - Data Link Control (DLC) layer";**
- Part 5: "Abstract Test Suite (ATS) - Data Link Control (DLC) layer";
- Part 6: "Test Suite Structure (TSS) and Test Purposes (TP) - Network (NWK) layer - Portable radio Termination (PT)";
- Part 7: "Abstract Test Suite (ATS) for Network (NWK) layer - Portable radio Termination (PT)";
- Part 8: "Test Suite Structure (TSS) and Test Purposes (TP) - Network (NWK) layer - Fixed radio Termination (FT)";
- Part 9: "Abstract Test Suite (ATS) for Network (NWK) layer - Fixed radio Termination (FT)".

Proposed national transposition dates	
Date of latest announcement of the present document (doa):	3 months after ETSI publication
Date of latest publication of new National Standard or endorsement of the present document (dop/e):	6 months after doa
Date of withdrawal of any conflicting National Standard (dow):	6 months after doa

1 Scope

The present document contains the Test Suite Structure (TSS) and Test Purposes (TP) to test the Digital Enhanced Cordless Telecommunications (DECT) Data Link Control (DLC) layer.

The objective of this test specification is to provide a basis for approval tests for DECT equipment giving a high probability of air interface inter-operability between different manufacturer's DECT equipment.

The ISO standard for the methodology of conformance testing (ISO/IEC 9646-1 [10] and ISO/IEC 9646-2 [11]) as well as the ETSI rules for conformance testing (ETS 300 406 [9]) are used as the basis for the test methodology.

Test specifications for the Physical Layer (PHL), Medium Access Control (MAC) layer, and Network (NWK) layer are provided in other the DECT standards.

2 References

The following documents contain provisions which, through reference in this text, constitute provisions of the present document.

- References are either specific (identified by date of publication, edition number, version number, etc.) or non-specific.
- For a specific reference, subsequent revisions do not apply.
- For a non-specific reference, the latest version applies.
- A non-specific reference to an ETS shall also be taken to refer to later versions published as an EN with the same number.

- [1] EN 300 175-1: "Digital Enhanced Cordless Telecommunications (DECT); Common Interface (CI); Part 1: Overview".
- [2] EN 300 175-2: "Digital Enhanced Cordless Telecommunications (DECT); Common Interface (CI); Part 2: Physical Layer (PHL)".
- [3] EN 300 175-3: "Digital Enhanced Cordless Telecommunications (DECT); Common Interface (CI); Part 3: Medium Access Control (MAC) layer".
- [4] EN 300 175-4: "Digital Enhanced Cordless Telecommunications (DECT); Common Interface (CI); Part 4: Data Link Control (DLC) layer".
- [5] EN 300 175-5: "Digital Enhanced Cordless Telecommunications (DECT); Common Interface (CI); Part 5: Network (NWK) layer".
- [6] EN 300 175-6: "Digital Enhanced Cordless Telecommunications (DECT); Common Interface (CI); Part 6: Identities and addressing".
- [7] EN 300 175-7: "Digital Enhanced Cordless Telecommunications (DECT); Common Interface (CI); Part 7: Security features".
- [8] EN 300 175-8: "Digital Enhanced Cordless Telecommunications (DECT); Common Interface (CI); Part 8: Speech coding and transmission".
- [9] ETS 300 406: "Methods for Testing and Specification (MTS); Protocol and profile conformance testing specifications; Standardization methodology".
- [10] ISO/IEC 9646-1: "Information technology; Open Systems Interconnection; Conformance testing methodology and framework; Part 1: General concepts".
- [11] ISO/IEC 9646-2: "Information technology; Open Systems Interconnection; Conformance testing methodology and framework; Part 2: Abstract Test Suite Specification".

- [12] Directive 98/13/EC of the European Parliament and of the Council of 12 February 1998 relating to telecommunications terminal equipment and satellite earth station equipment, including the mutual recognition of their conformity.
- [13] TBR 6: "Digital Enhanced Cordless Telecommunications (DECT); General terminal attachment requirements".
- [14] TBR 10: "Digital Enhanced Cordless Telecommunications (DECT); General terminal attachment requirements; Telephony applications".
- [15] TBR 22 including Amendment 2: "Digital Enhanced Cordless Telecommunications (DECT); Attachment requirements for terminal equipment for DECT Generic Access Profile (GAP) applications".

3 Definitions and abbreviations

3.1 Definitions

For the purposes of the present document, the definitions given in ISO/IEC 9646-1 [10], ISO/IEC 9646-2 [11], EN 300 175-1 [1], EN 300 175-4 [4], EN 300 175-6 [6] and EN 300 175-7 [7] apply.

3.2 Abbreviations

For the purposes of the present document, the following abbreviations apply:

BI	Invalid Behaviour
BO	Inopportune Behaviour
BV	Valid Behaviour
C/L	Connectionless mode
C/O	Connection Oriented mode
CA	Capability tests
C-plane	Control plane
DECT	Digital Enhanced Cordless Telecommunications
DLC	Data Link Control layer
FP	Fixed Part
FT	Fixed radio Termination
IUT	Implementation Under Test
LAPC	a DLC layer C-plane protocol entity
Lb	a DLC broadcast entity
LLME	Lower Layer Management Entity
LT	Lower Tester
MAC	Medium Access Control layer
NWK	Network layer
PDU	Protocol Data Unit
PHL	Physical Layer
PICS	Protocol Implementation Conformance Statement
PIXIT	Protocol Implementation Extra Information for Testing
PP	Portable Part
PT	Portable radio Termination
RFP	Radio Fixed Part
SAPI	Service Access Point Identifier
TDMA	Time Division Multiple Access
TP	Test Purposes
TSS	Test Suite Structure
ULI	Unassigned Link Identifier (U-Plane)
U-plane	User plane

4 Test Suite Structure (TSS)

4.1 Overview

The Data Link Control (DLC) layer is layer 2b of the DECT protocol stack. The separation of the user information from the DECT signalling data is managed by the allocation of two independent planes:

- the User plane (U-plane); and
- the Control plane (C-plane).

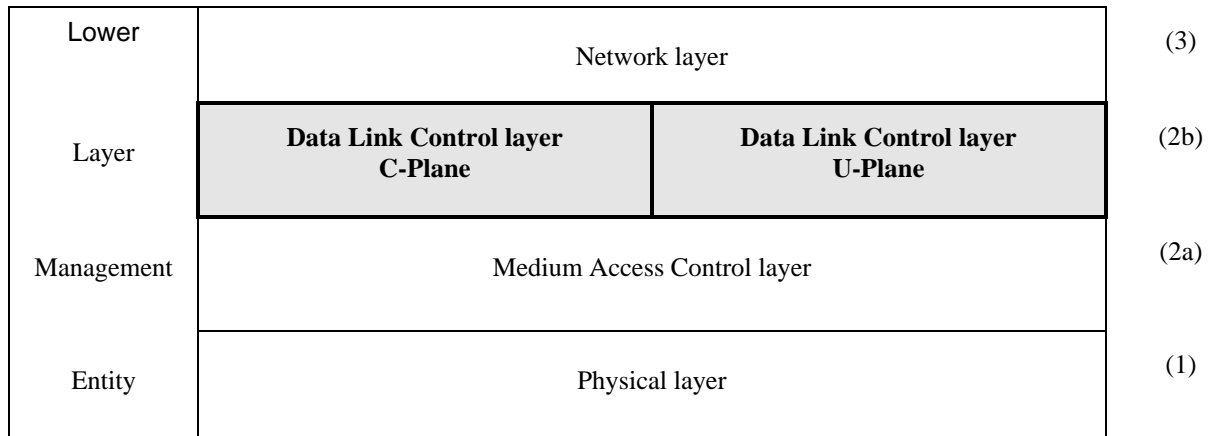

Figure 1: DECT protocol stack

The U-plane is the part of the DLC implementation that is responsible for the transmission of the user data. The U-plane may provide a series of different services and facilities, grouped into categories (LUX families).

The C-Plane is the second part of DECT DLC and is mainly involved with the transfer of signalling information. It provides the means to support DECT Connection Oriented, Connectionless and Broadcast services (the broadcast service exists only at the FT to PT direction). DECT DLC provides three classes of operation (Unacknowledged for C/L services, Single frame and Multiframe for C/O services).

At the DLC layer, C-plane and U-plane resources are considered as completely independent. The association of C and U-plane resources to serve a higher layer service (e.g. to setup and maintain a call) is a NWK layer responsibility. Moreover, no interaction is required between the services provided by each of the planes.

Figure 2 shows the DLC (TSS) including its subgroups and defined for the conformance testing.

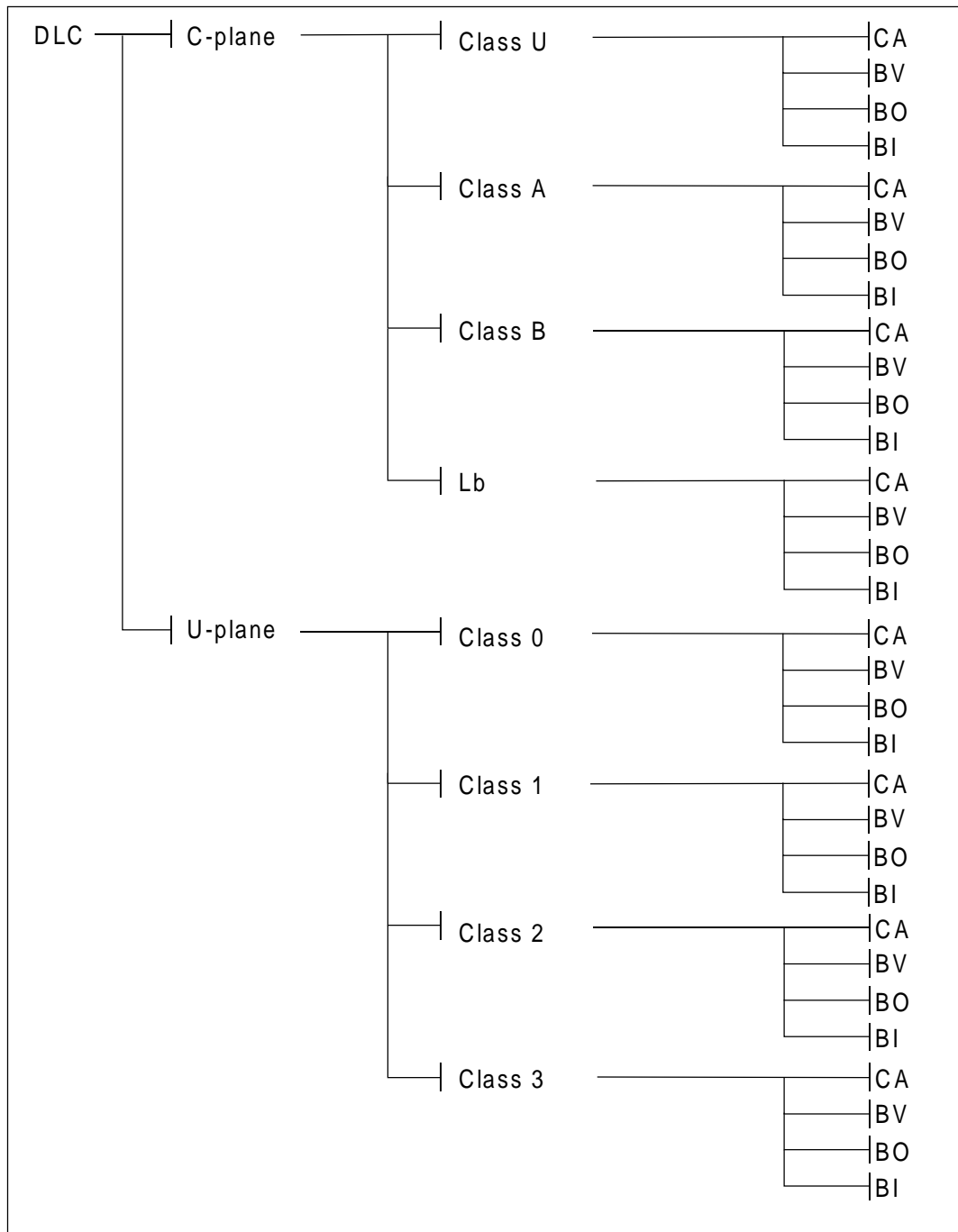

Figure 2: DLC TSS

4.2 TSS

The test suite is structured as a tree with a first level defined as DLC representing the protocol group "DLC for Portable Part (PP) and Fixed Part (FP)".

4.3 Test groups

The test groups are organized in three levels. The first level creates two protocol groups representing the protocol plane. The second level separates the protocol plane in functional modules. The last level contains the standard ISO subgroups CA, BV, BO and BI.

4.3.1 Protocol groups

The protocol groups identifies the DECT DLC planes, C-Plane and U-Plane, as defined in EN 300 175 [1] to [8].

4.3.1.1 C-plane

The C-plane protocol group is divided in four functional modules. The first functional module identifies the LAPC Class U services. The second functional module identifies the LAPC Class A services. The third functional module identifies the LAPC Class B services. The last functional module identifies the broadcast services Lb.

4.3.1.2 U-plane

The U-plane protocol group is divided in four functional modules. The first functional module identifies the Class 0 transmission procedures. The second functional module identifies the Class 1 transmission procedures. The third functional module identifies the Class 2 transmission procedures. The last functional module identifies the Class 3 transmission procedures.

4.3.2 Main test groups

The main test groups are the Capability group (CA), the Valid Behaviour group (BV), the inopportune Behaviour group (BO) and the Invalid Behaviour group (BI).

4.3.2.1 Capability (CA) tests

This test sub group shall provide limited testing of the major IUT capabilities aiming to assure that the claimed capabilities are correctly supported, in accordance with the PICS.

4.3.2.2 Valid Behaviour (BV) tests

This test sub group shall verify that the IUT reacts in conformity with the standard, on receipt or exchange of a valid Protocol Data Units (PDUs). Valid PDUs, means, that the exchange of messages and the content of the exchanged messages are considered as valid.

4.3.2.3 Inopportune Behaviour (BO) tests

This test sub group shall verify that the IUT is capable of a valid reaction, when an inopportune protocol event occurs. Such an event is syntactically correct but it occurs when it is not expected.

4.3.2.4 Invalid Behaviour (BI) tests

This test sub group shall verify that the IUT reacts in conformity with the standard, on receipt of a syntactically invalid Protocol Data Unit (PDU).

5 Test Purposes (TP)

5.1 Introduction

5.1.1 TP definition conventions

The TPs are defined following particular rules as shown in the table 1.

Table 1: TP definition rules

TP Id according to the TP naming conventions	Reference Initial condition Stimulus Expected behaviour
TP Id	The TP Id is a unique identifier it shall be specified according to the TP naming conventions defined in the subclause below.
Reference	The reference should contain the references of the subject to be validated by the actual TP (specification reference, clause, paragraph).
Condition	The condition defines in which initial state the IUT has to be to apply the actual TP.
Stimulus	The stimulus defines the test event to which the TP is related.
Expected behaviour	Definition of the events that are expected from the IUT to conform to the base specification.

5.1.2 TP naming conventions

The identifier of the TP is built according to table 2.

Table 2: TP naming convention

Identifier: TP<fm>x-<nnn>				
<fm> = functional module	U		C-plane Class U services	
	A		C-plane Class A services	
	B		C-plane Class B services	
	L		C-plane Broadcast services	
	0		U-plane transmission Class 0	
	1		U-plane transmission Class 1	
	2		U-plane transmission Class 2	
	3		U-plane transmission Class 3	
	x = Type of testing	C		CA, Capability Tests
		V		BV, Valid Behaviour Tests
O			BO, Inopportune Behaviour Tests	
I			BI, Invalid Behaviour Tests	
<nnn> = sequential number	(000-999)		Test Purpose Number	

5.1.3 Sources of TP definitions

All TPs are specified according to EN 300 175-4 [4]. The functions of the LC entity (frame delimiting, checksum generation / checking, fragmentation of DLC frames, and routing of frame to/from logical channels) are implicitly covered by the TP designed for the C-plane.

5.2 C-plane

5.2.1 LAPC Class U service

5.2.1.1 CA tests

DLC/C-Plane/ClassU/TPUC-000	EN 300 175-4 [4], subclause 9.3. Only applicable when a procedure is specified in the PIXIT to force the IUT to send an UI frame. Verify that the IUT is able to generate an UI frame by using MAC connectionless services.
DLC/C-Plane/ClassU/TPUC-001	EN 300 175-4 [4], subclause 9.3. Only applicable when a procedure is specified in the PIXIT to force the IUT to send an UI frame. Verify that the IUT is able to generate an UI frame by using an open MAC connection.
DLC/C-Plane/ClassU/TPUC-002	EN 300 175-4 [4], subclause 9.3. Only applicable when a procedure is specified in the PIXIT to determine UI frame reception. Verify that the IUT is able to receive an UI frame over MAC connectionless services.
DLC/C-Plane/ClassU/TPUC-003	EN 300 175-4 [4], subclause 9.3. Only applicable when a procedure is specified in the PIXIT to determine UI frame reception. Verify that the IUT is able to receive an UI frame over an open MAC connection.

5.2.1.2 BV tests

DLC/C-Plane/ClassU/TPUV-000	EN 300 175-4 [4], subclause 9.3.2. Only applicable when a procedure is specified in the PIXIT to determine UI frame reception. Verify that the IUT, on receipt of the first UI frame in an open MAC connection, considers the Class U link as established.
DLC/C-Plane/ClassU/TPUV-001	EN 300 175-4 [4], subclause 9.3.4. Only applicable when a procedure is specified in the PIXIT to determine UI frame reception. Verify that the IUT, on receipt of the a Class U upward release from the peer DLC entity in an open MAC connection, considers the Class U link as released.

5.2.1.3 BI tests

DLC/C-Plane/ClassU/TPUI-000	EN 300 175-4 [4], subclause 9.3.3.2. Only applicable when a procedure is specified in the PIXIT to determine UI frame reception. Verify that the IUT, on receipt of an UI frame with P bit set to '1', accepts this erroneous frame. The UI frame is transmitted over MAC connectionless services.
DLC/C-Plane/ClassU/TPUI-001	EN 300 175-4 [4], subclause 9.3.3.2. Only applicable when a procedure is specified in the PIXIT to determine UI frame reception. Verify that the IUT, on receipt of an UI frame with P bit set to '1', accepts this erroneous frame. The UI frame is transmitted over an open MAC connection.
DLC/C-Plane/ClassU/TPUI-002	EN 300 175-4 [4], subclause 9.3.3.2. Only applicable when a procedure is specified in the PIXIT to determine UI frame reception. Verify that the IUT, on receipt of an UI frame with NLF bit set to '1', accepts this erroneous frame. The UI frame is transmitted over MAC connectionless services.
DLC/C-Plane/ClassU/TPUI-003	EN 300 175-4 [4], subclause 9.3.3.2. Only applicable when a procedure is specified in the PIXIT to determine UI frame reception. Verify that the IUT, on receipt of an UI frame with NLF bit set to '1', accepts this erroneous frame. The UI frame is transmitted over an open MAC connection.
DLC/C-Plane/ClassU/TPUI-004	EN 300 175-4 [4], subclause 9.3.3.2. Only applicable when a procedure is specified in the PIXIT to determine UI frame reception. Verify that the IUT discards a UI frame with improper LLN (not Class U operation). The UI frame is transmitted over MAC connectionless services.
DLC/C-Plane/ClassU/TPUI-005	EN 300 175-4 [4], subclause 9.3.3.2. Only applicable when a procedure is specified in the PIXIT to determine UI frame reception. Verify that the IUT discards a UI frame with improper LLN (not Class U operation). The UI frame is transmitted over an open MAC connection.
DLC/C-Plane/ClassU/TPUI-006	EN 300 175-4 [4], subclause 9.3.3.2. Only applicable when a procedure is specified in the PIXIT to determine UI frame reception. Verify that the IUT discards a UI frame with improper Service Access Point Identifier (SAPI) (not "connectionless"). The UI frame is transmitted over MAC connectionless services.
DLC/C-Plane/ClassU/TPUI-007	EN 300 175-4 [4], subclause 9.3.3.2. Only applicable when a procedure is specified in the PIXIT to determine UI frame reception. Verify that the IUT discards a UI frame with improper SAPI (not "connection oriented"). The UI frame is transmitted over an open MAC connection.

5.2.1.4 BO tests

In an open MAC connection, transmitting or receiving UI frames is ever possible and inopportune TPs can not be defined.

5.2.2 LAPC Class A service

5.2.2.1 CA tests

DLC/C-Plane/ClassA/TPAC-000	<p>EN 300 175-4 [4], subclause 9.2.3.1. Only for IUT that is able to send the establishment request of the data link. Initial condition: The IUT has sent the link establishment request and is now in establishment pending state. Verify that the IUT re-transmits the same link establishment I-Frame request N250 times if, at each request, the timer <DL-07> expires and the expected RR response frame with the NLF bit set to '1' is not received and enters established state, if in the last re-transmission it receives the expected RR with the NLF bit set to '1'.</p>
DLC/C-Plane/ClassA/TPAC-001	<p>EN 300 175-4 [4], subclause 9.2.3.1. Only for IUT that is able to send the establishment request of the data link. Initial condition: The IUT has sent the link establishment request and is now in establishment pending state. Verify that the IUT, on receipt of a valid RR frame response to the link establishment request it has sent, enters established state.</p>
DLC/C-Plane/ClassA/TPAC-002	<p>EN 300 175-4 [4], subclause 9.2.3.8. Only for IUT that is able to send the establishment request of the data link. Initial condition: The IUT has sent the link establishment request to re-establish the link and is now in re-establishment pending state. Verify that the IUT re-transmits the same link establishment I-Frame request N250 times if, at each request, the timer <DL-07> expires and the expected RR response frame with the NLF bit set to '1' is not received and enters established state, if in the last re-transmission it receives the expected RR with the NLF bit set to '1'.</p>
DLC/C-Plane/ClassA/TPAC-003	<p>EN 300 175-4 [4], subclause 9.2.3.8. Only for IUT that is able to send the establishment request of the data link. Initial condition: The IUT has sent the link establishment request to re-establish the link and is now in re-establishment pending state. Verify that the IUT, on receipt of a valid RR frame response to the link re-establishment request it has sent, enters established state.</p>
DLC/C-Plane/ClassA/TPAC-005	<p>EN 300 175-4 [4], subclause 9.2.3.4. Initial condition: The IUT is in Class A established state. Verify that the IUT acknowledges rightly a valid received I-Frame within timer <DL-04>.</p>
DLC/C-Plane/ClassA/TPAC-006	<p>EN 300 175-4 [4], subclause 9.2.3.6. Initial condition: The IUT is in Class A established state. Verify that the IUT re-transmits N250 times the same I-Frame if, at each transmission, the timer <DL-04> expires and the expected acknowledgement is not received and remains in established state, if in the last re-transmission it receives the expected acknowledgement.</p>
DLC/C-Plane/ClassA/TPAC-007	<p>EN 300 175-4 [4], subclause 9.2.2.1. For IUT that implement only Class A operation (no Class B). Initial condition: The IUT is in Unassigned Link Identifier (ULI) state. Verify that the IUT, on receipt of the Class B link establishment I-Frame request, refuses this request by sending RR response frame with the reserved LLN value "Class A operation" and NLF bit set to "1", and enters into the Class A established state.</p>
DLC/C-Plane/ClassA/TPAC-008	<p>EN 300 175-4 [4], subclause 9.2.3.1. Initial condition: The IUT is in ULI state. Verify that the IUT, on receipt of a valid link establishment I-Frame request, responds with a RR response frame with the NLF bit set to "1" and enters into the Class A established state.</p>

5.2.2.2 BV tests

DLC/C-Plane/ClassA/TPAV-000	EN 300 175-4 [4], subclause 9.2.3.1. Only for IUT that is able to send and to receive the establishment request of the data link. Initial condition: The IUT has sent the link establishment request and is now in establishment pending state (timer <DL-07> is active). Verify that the IUT accepts an I-Frame indicating Class A link establishment, responds with a RR response frame with the NLF bit set and establishes Class A operation. (Collision of establishment requests)
DLC/C-Plane/ClassA/TPAV-002	EN 300 175-4 [4], subclause 9.2.3.5. Initial condition: The IUT is in Class A established state and has sent an I-Frame. Verify that the IUT accepts as an acknowledgement for a previously transmitted I-Frame, a RR response frame with correct N(R) value.
DLC/C-Plane/ClassA/TPAV-003	EN 300 175-4 [4], subclause 9.2.3.5. Initial condition: The IUT is in Class A established state and has sent an I-Frame. Verify that the IUT accepts as an acknowledgement for a previously transmitted I-Frame, an I-Frame command with correct N(S) and N(R) values.
DLC/C-Plane/ClassA/TPAV-005	EN 300 175-4 [4], subclause 9.2.3.6. Initial condition: The IUT is in timer recovery phase. Verify that the IUT accepts as an acknowledgement for a previously transmitted I-Frame, a RR response frame with correct N(R) value and leaves the timer recovery phase.
DLC/C-Plane/ClassA/TPAV-006	EN 300 175-4 [4], subclause 9.2.3.6. Initial condition: The IUT is in timer recovery phase. Verify that the IUT accepts as an acknowledgement for a previously transmitted I-Frame, an I-Frame with correct N(S) and N(R) values and leaves the timer recovery phase.
DLC/C-Plane/ClassA/TPAV-007	EN 300 175-4 [4], subclause 9.2.7.3.1. Initial condition: The IUT is in established state. Verify that the IUT manages rightly the PT intracell procedure for connection handover.
DLC/C-Plane/ClassA/TPAV-008	EN 300 175-4 [4], subclause 9.2.7.3.1. Initial condition: The IUT is in established state. Verify that the IUT manages rightly the PT intercell procedure for connection handover.

5.2.2.3 BI tests

DLC/C-Plane/ClassA/TPAI-000	EN 300 175-4 [4], subclause 9.2.3.1. Only for IUT that is able to send the establishment request of the data link. Initial condition: The IUT has sent the link establishment request and is now in establishment pending state (timer <DL-07> is active). Verify that the IUT, on receipt of a RR Class B response frame with NLF bit set to '1', discards the received frame and, on expiration of the timer <DL-07>, re-transmits the establishment request.
DLC/C-Plane/ClassA/TPAI-001	EN 300 175-4 [4], subclause 9.2.3.1. Only for IUT that is able to send the establishment request of the data link. Initial condition: The IUT has sent the link establishment request and is now in establishment pending state (timer <DL-07> is active). Verify that the IUT, on receipt of a RR response frame with NLF bit set to '1' and invalid N(R), discards the received RR response frame and, on expiration of the timer <DL-07>, re-transmits the establishment request.
DLC/C-Plane/ClassA/TPAI-002	EN 300 175-4 [4], subclause 9.2.3.8. Only for IUT that is able to send the establishment request of the data link. Initial condition: The IUT has sent the establishment request to r-establish the link and is waiting for the acknowledgement of the request. Verify that the IUT, on receipt of a RR Class B response frame with NLF bit set to '1', discards the received frame and, on expiration of the timer <DL-07>, re-transmits the re-establishment request.
DLC/C-Plane/ClassA/TPAI-003	EN 300 175-4 [4], subclause 9.2.3.8. Only for IUT that is able to send the establishment request of the data link. Initial condition: The IUT has sent the establishment request to r-establish the link and is waiting for the acknowledgement of the request. Verify that the IUT, on receipt of a RR response frame with NLF bit set to '1' and invalid N(R), discards the received RR response frame and, on expiration of the timer <DL-07>, re-transmits the re-establishment request.
DLC/C-Plane/ClassA/TPAI-004	EN 300 175-4 [4], subclause 9.2.3.6. Initial condition: The IUT, in Class A established state, has sent an -Frame and is waiting for the adequate acknowledgement. Verify that the IUT, on receipt of a RR Class B response frame with NLF bit set to '0', discards the received frame and, on expiration of the timer <DL-04>, re-transmits the unacknowledged I-Frame.
DLC/C-Plane/ClassA/TPAI-005	EN 300 175-4 [4], subclause 9.2.3.5. Initial condition: The IUT, in Class A established state, has sent an -Frame and is waiting for the adequate acknowledgement. Verify that the IUT, on receipt of a RR response frame with NLF bit set to '0' and invalid N(R), discards the received RR response frame and, on expiration of the timer <DL-04>, re-transmits the unacknowledged -Frame.
DLC/C-Plane/ClassA/TPAI-006	EN 300 175-4 [4], subclause 9.2.3.5. Initial condition: The IUT, in Class A established state, has sent an -Frame and is waiting for the adequate acknowledgement. Verify that the IUT, on receipt of an I-Frame with invalid N(R), accepts the received frame and, on expiration of the timer <DL-04>, re-transmits the unacknowledged I-Frame with N(R) set to correctly acknowledge the received I-Frame.
DLC/C-Plane/ClassA/TPAI-007	EN 300 175-4 [4], subclause 9.2.3.4. Initial condition: The IUT, in Class A established state, has sent an I-Frame and is waiting for the adequate acknowledgement. Verify that the IUT, on receipt of an I-Frame with invalid N(S), responds with a RR response frame or an I-Frame indicating in the N(R) field the expected N(S) of the received I-Frame and accepts the N(R) of the I-Frame as an acknowledgement for the previously transmitted frame.
DLC/C-Plane/ClassA/TPAI-008	EN 300 175-4 [4], subclause 9.2.3.6. Initial condition: The IUT, in Class A established state, has sent an I-Frame and is waiting for the adequate acknowledgement. Verify that the IUT, on receipt of an I-Frame with invalid N(S) and invalid N(R), responds with a RR response frame indicating in the N(R) field the expected N(S) of the received I-Frame, and, on expiration of the timer <DL-04>, re-transmits the unacknowledged I-Frame.

DLC/C-Plane/ClassA/TPAI-009	EN 300 175-4 [4], subclause 9.2.3.6. Initial condition: The IUT is in timer recovery phase. Verify that the IUT, on receipt of a RR Class B response frame with NLF bit set to '0', discards the received frame, it remains in timer recovery phase, and, on expiration of the timer <DL-04>, re-transmits the unacknowledged I-Frame.
DLC/C-Plane/ClassA/TPAI-011	EN 300 175-4 [4], subclause 9.2.3.6. Initial condition: The IUT is in timer recovery phase. Verify that the IUT, on receipt of an I-Frame with invalid N(R), accepts the received I-Frame and responds with an appropriate RR frame and, on expiration of the timer <DL-04>, re-transmits the unacknowledged I-Frame with N(R) set according to the last accepted I-Frame.
DLC/C-Plane/ClassA/TPAI-012	EN 300 175-4 [4], subclause 9.2.3.6. Initial condition: The IUT is in timer recovery phase. Verify that the IUT, on receipt of an I-Frame with invalid N(S), responds with an RR response frame or an I-frame, indicating in the N(R) field the expected N(S) of the received I-Frame, and leaves timer recovery phase because the N(R) of the received I-Frame is a valid acknowledgement for the I-Frame it has previously transmitted.
DLC/C-Plane/ClassA/TPAI-013	EN 300 175-4 [4], subclause 9.2.3.6. Initial condition: The IUT is in timer recovery phase. Verify that the IUT, on receipt of an I-Frame with invalid N(S) and invalid N(R), responds with a RR response frame indicating in the N(R) field the N(S) of the expected I-Frame and, re-transmits the last unacknowledged I-Frame.

5.2.2.4 BO tests

DLC/C-Plane/ClassA/TPAO-000	EN 300 175-4 [4], subclause 9.2.3.1. Only for IUT that is able to send the establishment request of the data link. Initial condition: The IUT has sent the link establishment request and is now in establishment pending state. Verify that the IUT, on receipt of an I-Frame with NLF bit set to '0', discards the received frame and, on expiration of the timer <DL-07>, re-transmits the establishment request.
DLC/C-Plane/ClassA/TPAO-001	EN 300 175-4 [4], subclause 9.2.3.1. Only for IUT that is able to send the establishment request of the data link. Initial condition: The IUT has sent the link establishment request and is now in establishment pending state. Verify that the IUT, on receipt of a RR response frame with NLF bit set to '0', discards the received RR response frame and, on expiration of the timer <DL-07>, re-transmits the establishment request.
DLC/C-Plane/ClassA/TPAO-002	EN 300 175-4 [4], subclause 9.2.3.8. Only for IUT that is able to send the establishment request of the data link. Initial condition: The IUT has sent the establishment request to re-establish the link and is waiting for the acknowledgement of the request. Verify that the IUT, on receipt of an I-Frame with NLF bit set to '0', discards the received frame and, on expiration of the timer <DL-07>, re-transmits the re-establishment request.
DLC/C-Plane/ClassA/TPAO-003	EN 300 175-4 [4], subclause 9.2.3.8. Only for IUT that is able to send the establishment request of the data link. Initial condition: The IUT has sent the establishment request to re-establish the link and is waiting for the acknowledgement of the request. Verify that the IUT, on receipt of a RR response frame with NLF bit set to '0', discards the received RR response frame and, on expiration of the timer <DL-07>, re-transmits the re-establishment request.

5.2.3 LAPC Class B service

5.2.3.1 CA tests

No TPs are defined for LAPC Class B service CA tests in the present document.

5.2.3.2 BV tests

No TPs are defined for LAPC Class B service BV tests in the present document.

5.2.3.3 BI tests

No TPs are defined for LAPC Class B service BI tests in the present document.

5.2.3.4 BO tests

No TPs are defined for LAPC Class B service BO tests in the present document.

5.2.4 Broadcast service (Lb)

5.2.4.1 CA tests

DLC/C-Plane/Lb/TPLC-000	EN 300 175-4 [4], subclause 5.2. For Fixed radio termination only. Verify that the IUT is able to generate a broadcast frame of the short frame format (3 octets). For Portable radio termination only. Verify that the IUT is able to receive a broadcast frame of the short frame format (3 octets).
DLC/C-Plane/Lb/TPLC-001	EN 300 175-4 [4], subclause 5.2. For Fixed radio termination only. Verify that the IUT is able to generate a broadcast frame of the long frame format (5 octets). For Portable radio termination only. Verify that the IUT is able to receive a broadcast frame of the long frame format (5 octets).
DLC/C-Plane/Lb/TPLC-002	EN 300 175-4 [4], subclause 9.4. For Fixed radio termination only. Verify that the IUT is able to transmit expedited broadcast message and normal broadcast message with prioritized queuing. For Portable radio termination only. Verify that the IUT is able to receive expedited broadcast message and normal broadcast message with prioritized queuing.

5.2.4.2 BV tests

No valid behaviour TP are defined because no statements are provided in the standard in case of reception or transmission of a broadcast message.

5.2.4.3 BI tests

No invalid behaviour TP are defined because the broadcast message content is only composed of higher layer information.

5.2.4.4 BO tests

No inopportune behaviour TP are defined because it is ever possible to receive or to transmit a broadcast message.

5.3 U-plane

5.3.1 Class 0 transmission procedures

5.3.1.1 CA tests

DLC/U-Plane/Class0/TP0C-000	EN 300 175-4 [4], subclause 14.3.2.1. Verify that the IUT is able to transmit a correct U-plane Class 0 frame.
DLC/U-Plane/Class0/TP0C-001	EN 300 175-4 [4], subclause 14.3.2.2. Verify that the IUT is able to receive a correct U-plane Class 0 frame.

5.3.1.2 BV tests

No valid behaviour TP are defined because Class 0 transmission provides no mechanisms for re-transmission or sequencing.

5.3.1.3 BI tests

No invalid behaviour TP are defined because, in Class 0 U-plane transmission, all frames are ever syntactically correct.

5.3.1.4 BO tests

No inopportune behaviour TP are defined because, in a Class 0 U-plane transmission, it is always possible to receive or to transmit a message.

5.3.2 Class 1 transmission procedures

5.3.2.1 CA tests

DLC/U-Plane/Class1/TP1C-000	EN 300 175-4 [4], subclause 14.3.3.1. Verify that the IUT is able to transmit a correct U-plane Class 1 frame.
DLC/U-Plane/Class1/TP1C-001	EN 300 175-4 [4], subclause 14.3.3.1. Verify that the IUT treats a received frame including an RN with the A/N bit set to '1', as an acknowledgement for all frames up to and including frame number RN.
DLC/U-Plane/Class1/TP1C-002	EN 300 175-4 [4], subclause 14.3.3.2. Verify that the IUT correctly acknowledges received frame(s) with appropriate send sequence number(s). (In-sequence frames)

5.3.2.2 BV tests

DLC/U-Plane/Class1/TP1V-000	EN 300 175-4 [4], subclause 14.3.3.1. Verify that the IUT disconnects the U-plane link, at the event of expiration of timer <DLU-01> without receiving the requested acknowledgement.
DLC/U-Plane/Class1/TP1V-001	EN 300 175-4 [4], subclause 14.3.3.1. Verify that the IUT resets timer <DLU-01> on receipt of a frame that includes a valid acknowledgement.
DLC/U-Plane/Class1/TP1V-002	EN 300 175-4 [4], subclause 14.3.3.1. Verify that the IUT maintains the <DLU-01> timer whenever the window size is reached (thereby halting further transmissions).

5.3.2.3 BI tests

DLC/U-Plane/Class1/TP1I-000	EN 300 175-4 [4], subclause 14.3.3.1. Verify that the IUT discards a received frame with an I/R bit set to '0'.
DLC/U-Plane/Class1/TP1I-001	EN 300 175-4 [4], subclause 14.3.3.1. Verify that the IUT discards a received frame with an A/N bit set to '0'.
DLC/U-Plane/Class1/TP1I-002	EN 300 175-4 [4], subclause 14.3.3.2. Verify that the IUT correctly acknowledges received frame(s) with erroneous send sequence number(s) after waiting for L(R) Time Division Multiple Access (TDMA) frames. (Out-of-sequence frames).

5.3.2.4 BO tests

No inopportune behaviour TP are defined because, in a Class 1 U-plane transmission, it is always possible to receive or to transmit a message.

5.3.3 Class 2 transmission procedures

5.3.3.1 CA tests

No TPs are defined for Class 2 transmission procedures CA tests in the present document.

5.3.3.2 BV tests

No TPs are defined for Class 2 transmission procedures BV tests in the present document.

5.3.3.3 BI tests

No TPs are defined for Class 2 transmission procedures BI tests in the present document.

5.3.3.4 BO tests

No inopportune behaviour TP are defined because, in a class 2 U-plane transmission, it is always possible to receive or to transmit a message.

5.3.4 Class 3 transmission procedures

5.3.4.1 CA tests

No TPs are defined for Class 3 transmission procedures CA tests in the present document.

5.3.4.2 BV tests

No TPs are defined for Class 3 transmission procedures BV tests in the present document.

5.3.4.3 BI tests

No TPs are defined for Class 3 transmission procedures BI tests in the present document.

5.3.4.4 BO tests

No inopportune behaviour TP are defined because, in a Class 3 U-plane transmission, it is always possible to receive or to transmit a message.

Bibliography

The following material, though not specifically referenced in the body of the present document, gives supporting information.

- EWOS/ETSI Project Team No 5: "Project Report and Technical Report. OSI Conformance Testing Methodology and Procedures in Europe".
- ETR 022: "Advanced Testing Methods (ATM); Vocabulary of terms used in communications protocols conformance testing".
- ETR 141: "Methods for Testing and Specification (MTS); Protocol and profile conformance testing specifications; The Tree and Tabular Combined Notation (TTCN) style guide".
- CEPT Recommendation T/SGT SF2 (89) 6/0: "Draft Recommendation T/SF Services and Facilities of Digital Enhanced Cordless Telecommunications".
- ETR 015: "Digital Enhanced Cordless Telecommunications (DECT); Reference document".
- ETR 041: "Transmission and Multiplexing (TM); Digital Enhanced Cordless Telecommunications (DECT); Transmission aspects 3,1 kHz telephony Interworking with other networks".
- ETR 042: "Digital European Cordless Telecommunications (DECT); A Guide to DECT features that influence the traffic capacity and the maintenance of high radio link transmission quality, including the results of simulations".
- ETR 043: "Digital European Cordless Telecommunications (DECT); Common interface (CI); Services and facilities requirements specification".
- ETR 056: "Digital European Cordless Telecommunications (DECT); System description document".

History

Document history		
Edition 1	August 1996	Publication as ETS 300 497-4
Edition 2	February 1998	Publication as ETS 300 497-4
V0.3.0	August 1998	Public Enquiry PE 9852: 1998-08-28 to 1998-12-25