

Draft **ETSI EN 300 440-1** V1.3.1 (2000-07)

European Standard (Telecommunications series)

**Electromagnetic compatibility
and Radio spectrum Matters (ERM);
Short range devices;
Radio equipment to be used
in the 1 GHz to 40 GHz frequency range;
Part 1: Technical characteristics and test methods**



Reference

REN/ERM-RP08-0406-1

Keywords

radio, testing, SRD

ETSI

650 Route des Lucioles
F-06921 Sophia Antipolis Cedex - FRANCE

Tel.: +33 4 92 94 42 00 Fax: +33 4 93 65 47 16

Siret N° 348 623 562 00017 - NAF 742 C
Association à but non lucratif enregistrée à la
Sous-Préfecture de Grasse (06) N° 7803/88

Important notice

Individual copies of the present document can be downloaded from:

<http://www.etsi.org>

The present document may be made available in more than one electronic version or in print. In any case of existing or perceived difference in contents between such versions, the reference version is the Portable Document Format (PDF).

In case of dispute, the reference shall be the printing on ETSI printers of the PDF version kept on a specific network drive within ETSI Secretariat.

Users of the present document should be aware that the document may be subject to revision or change of status.

Information on the current status of this and other ETSI documents is available at <http://www.etsi.org/tb/status/>

If you find errors in the present document, send your comment to:

editor@etsi.fr

Copyright Notification

No part may be reproduced except as authorized by written permission.
The copyright and the foregoing restriction extend to reproduction in all media.

© European Telecommunications Standards Institute 2000.
All rights reserved.

Contents

Intellectual Property Rights.....	6
Foreword	6
1 Scope	7
2 References	8
3 Definitions, symbols and abbreviations	8
3.1 Definitions	8
3.2 Symbols	9
3.3 Abbreviations	10
4 Technical requirements specifications	10
4.1 General requirements.....	10
4.1.1 Equipment classification	10
4.1.2 General performance criteria	10
4.2 Presentation of equipment for testing purposes	11
4.2.1 Choice of model for testing.....	11
4.2.2 Testing of equipment with alternative power levels.....	11
4.2.3 Testing of equipment that does not have an external 50 ohm RF connector (integral antenna equipment)	11
4.2.3.1 Equipment with an internal permanent or temporary antenna connector	11
4.2.3.2 Equipment with a temporary antenna connector	12
4.3 Mechanical and electrical design.....	12
4.3.1 General.....	12
4.3.2 Controls	12
4.3.3 Transmitter shut-off facility	12
4.3.4 Receiver mute or squelch.....	12
4.3.5 Marking (equipment identification)	12
4.3.5.1 Equipment identification	12
4.3.5.2 Regulatory marking	12
4.4 Declarations by the applicant	13
4.5 Auxiliary test equipment.....	13
4.6 Interpretation of the measurement results	13
5 Test conditions, power sources and ambient temperatures.....	13
5.1 Normal and extreme test conditions	13
5.2 Test power source.....	13
5.2.1 External test power source	13
5.2.2 Internal test power source	14
5.3 Normal test conditions.....	14
5.3.1 Normal temperature and humidity	14
5.3.2 Normal test power source	14
5.3.2.1 Mains voltage	14
5.3.2.2 Regulated lead-acid battery power sources	14
5.3.2.3 Other power sources.....	14
5.4 Extreme test conditions	14
5.4.1 Extreme temperatures	14
5.4.1.1 Procedure for tests at extreme temperatures.....	14
5.4.1.1.1 Procedure for equipment designed for continuous operation	15
5.4.1.1.2 Procedure for equipment designed for intermittent operation	15
5.4.1.2 Extreme temperature ranges	15
5.4.2 Extreme test source voltages.....	15
5.4.2.1 Mains voltage	15
5.4.2.2 Regulated lead-acid battery power sources	16
5.4.2.3 Power sources using other types of batteries.....	16
5.4.2.4 Other power sources.....	16

6	General conditions	16
6.1	Normal test signals and test modulation	16
6.1.1	Normal test signals for data	17
6.2	Artificial antenna	17
6.3	Test fixture	17
6.4	Test sites and general arrangements for radiated measurements	17
6.5	Measuring receiver	18
7	Methods of measurement and limits for transmitter parameters.....	18
7.1	Equivalent isotropically radiated power (eirp)	18
7.1.1	Definition.....	18
7.1.2	Method of measurement.....	18
7.1.2.1	Non spread spectrum transmitters with a -6 dB bandwidth up to 20 MHz.....	19
7.1.2.2	Other transmitters than defined in subclause 7.1.2.1	19
7.1.3	Limits.....	20
7.2	Permitted range of operating frequencies	21
7.2.1	Definition.....	21
7.2.2	Method of measurement.....	21
7.2.3	Method of measurement for equipment using FHSS modulation	22
7.2.4	Limit	22
7.3	Spurious emissions	23
7.3.1	Definition.....	23
7.3.2	Measuring receiver	23
7.3.3	Method of measurement conducted spurious emission	23
7.3.4	Method of measurement cabinet spurious radiation.....	24
7.3.5	Method of measurement radiated spurious emission	25
7.3.6	Additional requirements for equipment employing FHSS modulation	25
7.3.7	Limits.....	26
7.4	Duty cycle.....	26
7.4.1	Definitions	26
7.4.2	Declaration.....	26
7.4.3	Duty cycle classes	26
7.5	Additional requirements for FHSS equipment.....	27
7.5.1	FHSS modulation.....	27
7.5.2	FHSS transmit level during frequency hop	27
8	Receiver.....	27
8.1	Adjacent channel selectivity-in band	27
8.1.1	Definition.....	27
8.1.2	Method of measurement.....	27
8.1.3	Limits.....	28
8.2	Adjacent band selectivity.....	28
8.2.1	Definition.....	28
8.2.2	Method of measurement.....	28
8.2.3	Limits.....	29
8.3	Blocking or desensitization	29
8.3.1	Definition.....	29
8.3.2	Methods of measurement	29
8.3.3	Limits.....	30
8.4	Spurious emissions	30
8.4.1	Definition.....	30
8.4.2	Method of measurement conducted spurious components.....	30
8.4.3	Method of measurement cabinet radiation	31
8.4.4	Method of measurement radiated spurious components	31
8.4.5	Limits.....	32
9	Measurement uncertainty	32
Annex A (normative):	Radiated measurements	33
A.1	Test sites and general arrangements for measurements involving the use of radiated fields	33
A.1.1	Outdoor test site	33

A.1.1.1	Standard position	34
A.1.2	Test antenna.....	34
A.1.3	Substitution antenna	34
A.1.4	Optional additional indoor site	35
A.2	Guidance on the use of radiation test sites.....	35
A.2.1	Measuring distance.....	36
A.2.2	Test antenna.....	36
A.2.3	Substitution antenna	36
A.2.4	Artificial antenna	36
A.2.5	Auxiliary cables.....	36
A.3	Further optional alternative indoor test site using an anechoic chamber.....	36
A.3.1	Example of the construction of a shielded anechoic chamber	37
A.3.2	Influence of parasitic reflections in anechoic chambers	37
A.3.3	Calibration of the shielded RF anechoic chamber	38
Annex B (normative):	General description of measurement methods	40
B.1	Conducted measurements.....	40
B.2	Radiated measurements.....	40
Annex C (normative):	Transmitter spectrum mask for RFID systems operating in the 2,45 GHz ISM band	42
	Bibliography	43
	History	44

Intellectual Property Rights

IPRs essential or potentially essential to the present document may have been declared to ETSI. The information pertaining to these essential IPRs, if any, is publicly available for **ETSI members and non-members**, and can be found in ETSI SR 000 314: "*Intellectual Property Rights (IPRs); Essential, or potentially Essential, IPRs notified to ETSI in respect of ETSI standards*", which is available from the ETSI Secretariat. Latest updates are available on the ETSI Web server (<http://www.etsi.org/ipr>).

Pursuant to the ETSI IPR Policy, no investigation, including IPR searches, has been carried out by ETSI. No guarantee can be given as to the existence of other IPRs not referenced in ETSI SR 000 314 (or the updates on the ETSI Web server) which are, or may be, or may become, essential to the present document.

Foreword

This European Standard (Telecommunications series) has been produced by ETSI Technical Committee Electromagnetic compatibility and Radio spectrum Matters (ERM), and is now submitted for the Public Enquiry phase of the ETSI standards Two-step Approval Procedure.

For non EU countries the present document may be used for regulatory (Type Approval) purposes.

The present document is Part 1 of a two-part deliverable covering the Electromagnetic compatibility and Radio spectrum Matters (ERM); Short range devices; Radio equipment to be used in the 1 GHz to 40 GHz frequency range, as identified below:

Part 1: "Technical characteristics and test methods";

Part 2: "Harmonized EN under article 3.2 of the R&TTE Directive".

Clauses 1 and 3 provide a general description on the types of equipment covered by the present document and the definitions and abbreviations used. Clause 4 provides as a guide the number of samples required in order that type tests may be carried out and any markings on the equipment which the applicant has to provide.

Clauses 5 and 6 provide general test conditions to be used.

Clauses 7 and 8 specify the spectrum utilization parameters which are required to be measured. These are maximum limits which have been chosen to minimize harmful interference to other equipment or services. The clauses provide details on how the equipment should be tested and the conditions which should be applied.

Clause 9 gives the maximum measurement uncertainty values.

Annex A provides normative specifications concerning radiated measurements.

Annex B provides normative description of measurement methods.

Annex C is informative and details the parameters which are required to be measured for compliance with the Directive 1999/5/EC [2]. For further details, see Part 2 of the present document, EN 300 440-2 .

Proposed national transposition dates	
Date of latest announcement of this EN (doa):	3 months after ETSI publication
Date of latest publication of new National Standard or endorsement of this EN (dop/e):	6 months after doa
Date of withdrawal of any conflicting National Standard (dow):	6 months after doa

1 Scope

The present document applies to Short Range Devices (SRDs) transmitters and receivers:

- transmitters operating in range from 1 GHz to 40 GHz with power levels ranging up to 4W;
- receivers operating in the range from 1 GHz to 40 GHz.

The present document contains the technical characteristics for radio equipment and is referencing CEPT/ERC Recommendation for SRDs CEPT/ERC Recommendation 70-03 [3].

The present document does not necessarily include all the characteristics which may be required by a user, nor does it necessarily represent the optimum performance achievable. It is a product family standard which may be completely or partially superseded by specific standards covering specific applications.

The present document applies to generic SRDs:

- either with a Radio Frequency (RF) output connection and specified antenna, or with an integral antenna;
- for alarms, identification systems, radio-determination, telecommand, telemetry etc. applications;
- for all types of modulation;
- with or without speech.

The present document covers fixed stations, mobile stations and portable stations. If a system includes transponders, these are measured together with the transmitter.

All types of modulation for radio devices are covered by the present document, provided the requirements of subclause 7.2 are met.

The radio equipment, covered by the classification SRD is divided into several power classes based on maximum output power (see table 1). The power class designation is based on CEPT/ERC Recommendation 70-03 [3].

Table 1: Maximum radiated peak power (e.i.r.p.)

Power Class	Power level (conducted or radiated)
8	10 mW
9	25 mW
11	100 mW
12	500 mW
13	1 W
14	2 W
14a	4 W Note
NOTE: Under CEPT consideration	

The present document does not require measurements for radiated emissions below 25 MHz.

Additional standards or specifications may be required for equipment such as that intended for connection to the Public Switched Telephone Network (PSTN).

2 References

The following documents contain provisions which, through reference in this text, constitute provisions of the present document.

- References are either specific (identified by date of publication, edition number, version number, etc.) or non-specific.
- For a specific reference, subsequent revisions do not apply.
- For a non-specific reference, the latest version applies.
- A non-specific reference to an ETS shall also be taken to refer to later versions published as an EN with the same number.

- [1] ETSI EN 301 489-3 (V1.2.1): "Electromagnetic compatibility and Radio spectrum Matters (ERM); ElectroMagnetic Compatibility (EMC) standard for radio equipment and services; Part 3: Specific conditions for Short-Range Devices (SRD) operating on frequencies between 9 kHz and 40 GHz".
- [2] Directive 1999/5/EC of the European Parliament and of the Council of 9 March 1999 on radio equipment and telecommunications terminal equipment and the mutual recognition of their conformity".
- [3] CEPT/ERC Recommendation 70-03 (1997): "Relating to the use of Short Range Devices (SRD)".
- [4] CISPR 16-1: "Specification for radio disturbance and immunity measuring apparatus and methods; Part 1: Radio disturbance and immunity measuring apparatus".
- [5] ITU-T Recommendation O.153: "Basic parameters for the measurement of error performance at bit rates below the primary rate".
- [6] ETSI ETR 028: "Radio Equipment and Systems (RES); Uncertainties in the measurement of mobile radio equipment characteristics".
- [7] ITU-T Recommendation O.41: "Psophometer for use on telephone-type circuits".
- [8] CEPT/ERC Recommendation 74-01 (1998): "Spurious emissions"

3 Definitions, symbols and abbreviations

3.1 Definitions

For the purposes of the present document, the following terms and definitions apply:

alarm: use of radio communication for indicating an alarm condition at a distant location.

artificial antenna: non-radiating dummy load equal to the nominal impedance specified by the applicant.

assigned frequency band: frequency band within which the device is authorized to operate.

chip: unit of modulation used in Direct Sequence Spread Spectrum (DSSS) modulation.

chip rate: number of chips per second.

conducted measurements: measurements which are made using a direct connection to the equipment under test.

Direct Sequence Spread Spectrum (DSSS): form of modulation where a combination of data to be transmitted and a fixed code sequence (chip sequence) is used to directly modulate a carrier, e.g. by phase shift keying. The code sequence length determines the occupied bandwidth.

dedicated antenna: removable antenna supplied and type tested with the radio equipment, designed as an indispensable part of the equipment.

fixed station: equipment intended for use in a fixed location.

Frequency Hopping Spread Spectrum (FHSS): a spread spectrum technique in which the transmitter signal occupies a number of frequencies in time, each for some period of time, referred to as the dwell time. Transmitter and receiver follow the same frequency hop pattern. The number of hop positions and the bandwidth per hop position determine the occupied bandwidth.

identification system: equipment consisting of a transmitter(s), receiver(s) (or a combination of the two) and an antenna(s) to identify objects by means of a transponder.

integral antenna: permanent fixed antenna, which may be built-in, designed as an indispensable part of the equipment.

mobile station: equipment normally fixed in a vehicle or used as a transportable station.

portable station: equipment intended to be carried, attached or implanted.

operating frequency: nominal frequency at which equipment is operated; this is also referred to as the operating centre frequency. Equipment may be able to operate at more than one operating frequency.

operating frequency range: range of operating frequencies over which the equipment can be adjusted through tuning, switching or reprogramming.

radiated measurements: measurements which involve the absolute measurement of a radiated field.

radiodetermination: determination of the position, velocity and/or other characteristics of an object, or the obtaining of information relating to these parameters, by means of the propagation properties of radio waves.

spread spectrum: modulation technique in which the energy of a transmitted signal is spread throughout a large portion of the frequency spectrum.

telecommand: use of radio communication for the transmission of signals to initiate, modify or terminate functions of equipment at a distance.

telemetry: use of radio communication for indicating or recording data at a distance.

transponder: device which responds to an interrogation signal.

wideband: equipment to be used in a non-channelized continuous frequency band, or to be used in a channelized frequency band using more than one consecutive channel.

3.2 Symbols

For the purposes of the present document, the following symbols apply:

E	Electrical field strength
E ₀	Reference electrical field strength, (see Annex A)
f	Frequency
P	Power
R	Distance
R ₀	Reference distance, (see Annex A)
t	Time
λ	wavelength

3.3 Abbreviations

For the purposes of the present document, the following abbreviations apply:

dB	Decibel
dBi	gain in decibels relative to an isotropic antenna
DSSS	Direct Sequence Spread Spectrum
eirp	equivalent isotropically radiated power
EMC	ElectroMagnetic Compatibility
ERC	European Radiocommunication Committee
FHSS	Frequency Hopping Spread Spectrum
DSSS	Direct Sequence Spread Spectrum
PSTN	Public Switched Telephone Network
R&TTE	Radio and Telecommunications Terminal Equipment
RF	Radio Frequency
RFID	Radio Frequency Identification
SRD	Short Range Device
Tx	Transmitter
VSWR	Voltage Standing Wave Ratio

4 Technical requirements specifications

4.1 General requirements

4.1.1 Equipment classification

The product family of short range radio devices is divided into three equipment classes, see table 2, each having its own set of minimum performance criteria. This classification is based upon the impact on persons in case the equipment does not operate above the specified minimum performance level.

Table 2

Equipment class	Result of too low performance
1	Physical risk to persons
2	Inconvenience to persons, which cannot simply be overcome by other means
3	Inconvenience to persons, which can simply be overcome by other means (e.g. manual)

4.1.2 General performance criteria

For the purpose of the receiver performance tests, the receiver will produce an appropriate output under normal conditions as indicated below. Where the indicated performance cannot be achieved, the manufacturer shall declare and publish the performance criteria used to determine the performance of the receiver:

- a SND/ND ratio of 20 dB, measured at the receiver output through a telephone psophometric weighting network as described in ITU-T Recommendation O.41 [7]; or
- after demodulation, a data signal with a bit error ratio of 10^{-2} ; or
- after demodulation, a message acceptance ratio of 80 %.

4.2 Presentation of equipment for testing purposes

Each equipment submitted for testing shall fulfil the requirements of the present document on all frequencies over which it is intended to operate.

Where appropriate the applicant should chose appropriate frequencies in consultation with the Administration(s) from whom type approval is sought.

If an equipment is designed to operate with different carrier powers, measurements of each transmitter parameter shall be performed at the highest power level at which the transmitter is intended to operate.

Additionally, technical documentation and operating manuals, sufficient to allow testing to be performed, shall be supplied.

A test fixture for equipment with an integral antenna may be supplied by the applicant (see subclause 6.3).

To simplify and harmonize the testing procedures between the different testing laboratories, measurements shall be performed, according to the present document, on samples of equipment defined in subclauses 4.2.1 to 4.2.3.2.

These subclauses are intended to give confidence that the requirements set out in the present document have been met without the necessity of performing measurements on all frequencies.

4.2.1 Choice of model for testing

The applicant shall provide one or more samples of the equipment, as appropriate for testing.

Stand alone equipment shall be offered by the applicant complete with any ancillary equipment needed for testing.

If an equipment has several optional features, considered not to affect the RF parameters then the tests need only to be performed on the equipment configured with that combination of features considered to be the most complex, as proposed by the applicant and agreed by the test laboratory.

Where practicable, equipment offered for testing shall provide a 50 Ω connector for conducted RF power measurements.

In the case of integral antenna equipment, if the equipment does not have a internal permanent 50 Ω connector then it is permissible to supply a second sample of the equipment with a temporary antenna connector fitted to facilitate testing, see subclause 4.2.3.

4.2.2 Testing of equipment with alternative power levels

If a family of equipment has alternative output power levels provided by the use of separate power modules or add on stages, or additionally has alternative frequency coverage, then all these shall be declared by the applicant. Each module or add on stage shall be tested in combination with the equipment. The necessary samples and tests can be proposed by the applicant and/or the test laboratory and shall be agreed with the Administration(s), based on the requirements of subclause 4.2. As a minimum, measurements of the radiated power, eirp and spurious emissions shall be performed for each combination and shall be stated in the test report.

4.2.3 Testing of equipment that does not have an external 50 ohm RF connector (integral antenna equipment)

4.2.3.1 Equipment with an internal permanent or temporary antenna connector

The means to access and/or implement the internal permanent or temporary antenna connector shall be stated by the applicant with the aid of a diagram. The fact that use has been made of the internal antenna connection, or of a temporary connection, to facilitate measurements shall be recorded in the test report.

4.2.3.2 Equipment with a temporary antenna connector

The applicant may submit one set of equipment with the normal antenna connected, to enable radiated measurements to be made. The applicant shall attend the test laboratory at the conclusion of the radiated measurements, to disconnect the antenna and fit the temporary connector. The testing laboratory staff shall not connect or disconnect any temporary antenna connector.

Alternatively, the applicant may submit two sets of equipment to the test laboratory, one fitted with a temporary antenna connector with the antenna disconnected and another equipment with the antenna connected. Each equipment shall be used for the appropriate tests. The applicant shall declare that the two sets of equipment are identical in all aspects except for the antenna connector.

4.3 Mechanical and electrical design

4.3.1 General

The equipment submitted by the applicant shall be designed, constructed and manufactured in accordance with good engineering practice and with the aim of minimizing harmful interference to other equipment and services.

Transmitters and receivers may be individual or combination units.

4.3.2 Controls

Those controls which, if maladjusted, might increase the interfering potentialities of the equipment shall not be easily accessible to the user.

4.3.3 Transmitter shut-off facility

If the transmitter is equipped with an automatic transmitter shut-off facility, it should be made inoperative for the duration of the test.

4.3.4 Receiver mute or squelch

If the receiver is equipped with a mute, squelch or battery-saving circuit, this circuit shall be made inoperative for the duration of the tests.

4.3.5 Marking (equipment identification)

The equipment shall be marked in a visible place. This marking shall be legible and durable. Where this is not possible due to physical constraints, the marking shall be included in the users manual.

4.3.5.1 Equipment identification

The marking shall include as a minimum:

- the name of the manufacturer or his trademark;
- the type designation;
- equipment classification, see subclause 4.1.1.

4.3.5.2 Regulatory marking

The equipment shall be marked, where applicable, in accordance with CEPT/ERC Recommendation 70-03 [3] or the Directive 1999/5/EC [2], whichever is applicable. Where this is not applicable the equipment shall be marked in accordance with the National Regulatory requirements.

4.4 Declarations by the applicant

Where appropriate, the applicant shall supply the necessary information required by the appropriate application form.

4.5 Auxiliary test equipment

All necessary test signal sources and set-up information shall accompany the equipment when it is submitted for type testing.

4.6 Interpretation of the measurement results

The interpretation of the results recorded on the appropriate test report for the measurements described in the present document shall be as follows:

- the measured value relating to the corresponding limit shall be used to decide whether an equipment meets the requirements of the present document;
- the measurement uncertainty value for the measurement of each parameter shall be included in the test report;
- the recorded value of the measurement uncertainty shall, for each measurement, be equal to, or lower than, the figures in the table of measurement uncertainty (clause 9).

5 Test conditions, power sources and ambient temperatures

5.1 Normal and extreme test conditions

Type testing shall be made under normal test conditions, and also, where stated, under extreme test conditions.

The test conditions and procedures shall be as specified in subclauses 5.2 to 5.4.

5.2 Test power source

The equipment shall be tested using the appropriate test power source as specified in subclauses 5.2.1 or 5.2.2. Where equipment can be powered using either external or internal power sources, then the equipment shall be tested using the external power source as specified in subclause 5.2.1 then repeated using the internal power source as specified in subclause 5.2.2.

The test power source used shall be stated in the test report.

5.2.1 External test power source

During type tests, the power source of the equipment shall be replaced by an external test power source capable of producing normal and extreme test voltages as specified in subclauses 5.3.2 and 5.4.2. The internal impedance of the external test power source shall be low enough for its effect on the test results to be negligible. For the purpose of the tests, the voltage of the external test power source shall be measured at the input terminals of the equipment. The external test power source shall be suitably de-coupled as close to the equipment battery terminals as practicable. For radiated measurements any external power leads should be so arranged so as not to affect the measurements.

During tests the test power source voltages shall be within a tolerance of $< \pm 1\%$ relative to the voltage at the beginning of each test. The value of this tolerance can be critical for certain measurements. Using a smaller tolerance will provide a better uncertainty value for these measurements.

5.2.2 Internal test power source

For radiated measurements on portable equipment with integral antenna, fully charged internal batteries should be used. The batteries used should be as supplied or recommended by the applicant. If internal batteries are used, at the end of each test the voltage shall be within a tolerance of $< \pm 5\%$ relative to the voltage at the beginning of each test.

If appropriate, for conducted measurements or where a test fixture is used, an external power supply at the required voltage may replace the supplied or recommended internal batteries. This shall be stated on the test report.

5.3 Normal test conditions

5.3.1 Normal temperature and humidity

The normal temperature and humidity conditions for tests shall be any convenient combination of temperature and humidity within the following ranges:

- temperature $+15^{\circ}\text{C}$ to $+35^{\circ}\text{C}$;
- relative humidity 20 % to 75 %.

When it is impracticable to carry out tests under these conditions, a note to this effect, stating the ambient temperature and relative humidity during the tests, shall be added to the test report.

5.3.2 Normal test power source

5.3.2.1 Mains voltage

The normal test voltage for equipment to be connected to the mains shall be the nominal mains voltage. For the purpose of the present document, the nominal voltage shall be the declared voltage, or any of the declared voltages, for which the equipment was designed.

The frequency of the test power source corresponding to the ac mains shall be between 49 Hz and 51 Hz.

5.3.2.2 Regulated lead-acid battery power sources

When the radio equipment is intended for operation with the usual types of regulated lead-acid battery power source, the normal test voltage shall be 1,1 multiplied by the nominal voltage of the battery (e.g. 6 V, 12 V etc.).

5.3.2.3 Other power sources

For operation from other power sources or types of battery (primary or secondary), the normal test voltage shall be that declared by the equipment applicant and agreed by the accredited test laboratory. Such values shall be stated in the test report.

5.4 Extreme test conditions

5.4.1 Extreme temperatures

5.4.1.1 Procedure for tests at extreme temperatures

Before measurements are made the equipment shall have reached thermal balance in the test chamber. The equipment shall be switched off during the temperature stabilizing period.

In the case of equipment containing temperature stabilization circuits designed to operate continuously, the temperature stabilization circuits shall be switched on for 15 minutes after thermal balance has been obtained, and the equipment shall then meet the specified requirements.

If the thermal balance is not checked by measurements, a temperature stabilizing period of at least one hour, or such period as may be decided by the accredited test laboratory, shall be allowed. The sequence of measurements shall be chosen, and the humidity content in the test chamber shall be controlled so that excessive condensation does not occur.

5.4.1.1.1 Procedure for equipment designed for continuous operation

If the applicant states that the equipment is designed for continuous operation, the test procedure shall be as follows:

- before tests at the upper extreme temperature the equipment shall be placed in the test chamber and left until thermal balance is attained. The equipment shall then be switched on in the transmit condition for a period of a half hour after which the equipment shall meet the specified requirements;
- for tests at the lower extreme temperature, the equipment shall be left in the test chamber until thermal balance is attained, then switched on for a period of one minute after which the equipment shall meet the specified requirements.

5.4.1.1.2 Procedure for equipment designed for intermittent operation

If the applicant states that the equipment is designed for intermittent operation, the test procedure shall be as follows:

- before tests at the upper extreme temperature the equipment shall be placed in the test chamber and left until thermal balance is attained in the oven. The equipment shall then either:
 - transmit on and off according to the applicants declared duty cycle for a period of five minutes; or
 - if the applicant's declared on period exceeds one minute, then:
 - transmit in the on condition for a period not exceeding one minute, followed by a period in the off or standby mode for four minutes; after which the equipment shall meet the specified requirements.
- for tests at the lower extreme temperature, the equipment shall be left in the test chamber until thermal balance is attained, then switched to the standby or receive condition for one minute after which the equipment shall meet the specified requirements.

5.4.1.2 Extreme temperature ranges

For tests at extreme temperatures, measurements shall be made in accordance with the procedures specified in subclause 5.4.1.1, at the upper and lower temperatures of one of the following ranges:

- Category I (General): -20°C to +55°C;
- Category II (Portable): -10°C to +55°C;
- Category III (Equipment for normal indoor use): 0°C to +55°C.

NOTE: The term "Equipment for normal indoor use" is taken to mean the minimum indoor temperature is equal to or greater than +5 C.

For special applications, the manufacturer can specify wider temperature ranges than given as a minimum above. This shall be reflected in manufacturers product literature.

The test report shall state which range is used.

5.4.2 Extreme test source voltages

5.4.2.1 Mains voltage

The extreme test voltages for equipment to be connected to an ac mains source shall be the nominal mains voltage $\pm 10\%$. For equipment that operates over a range of mains voltages subclause 5.4.2.4 applies.

5.4.2.2 Regulated lead-acid battery power sources

When the radio equipment is intended for operation from the usual type of regulated lead-acid battery power sources the extreme test voltages shall be 1,3 and 0,9 multiplied by the nominal voltage of the battery (6 V, 12 V, etc.).

For float charge applications using "gel-cell" type batteries the extreme voltage shall be 1,15 and 0,85 multiplied by the nominal voltage of the declared battery voltage.

5.4.2.3 Power sources using other types of batteries

The lower extreme test voltages for equipment with power sources using batteries shall be as follows:

- for equipment with a battery indicator, the end point voltage as indicated;
- for equipment without a battery indicator the following end point voltages shall be used:
 - for the Leclanché or the lithium type of battery:
 - 0,85 multiplied by the nominal voltage of the battery;
 - for the nickel-cadmium type of battery:
 - 0,9 multiplied the nominal voltage of the battery;
- for other types of battery or equipment, the lower extreme test voltage for the discharged condition shall be declared by the equipment applicant.

The nominal voltage is considered to be the upper extreme test voltage in this case.

5.4.2.4 Other power sources

For equipment using other power sources, or capable of being operated from a variety of power sources, the extreme test voltages shall be those agreed between the equipment applicant and the accredited test laboratory. This shall be recorded in the test report.

6 General conditions

6.1 Normal test signals and test modulation

The test modulating signal is a signal which modulates a carrier, is dependent upon the type of equipment under test and also the measurement to be performed. Modulation test signals only apply to products with an external modulation connector. For equipment without an external modulation connector, normal operating modulation shall be used.

Where appropriate, a test signal shall be used with the following characteristics:

- representative of normal operation as declared by the applicant;
- causes greatest occupied RF bandwidth as declared.

For equipment using intermittent transmissions the test signal shall be such that:

- the generated RF signal is the same for each transmission;
- transmissions occur regularly in time;
- sequences of transmissions can be accurately repeated.

Details of the test signal shall be recorded in the test report.

Normal operating modulation shall be used, where there is no provision for external test modulation. For narrow band speech (≤ 120 kHz RF bandwidth) an unmodulated signal shall be used.

6.1.1 Normal test signals for data

Where the equipment has an external connection for general data modulation, the normal test signals are specified as follows:

- D-M2: a test signal representing a pseudo-random bit sequence of at least 511 bits in accordance with ITU-T Recommendation O.153 [5]. This sequence shall be continuously repeated. If the sequence cannot be continuously repeated, the actual method used shall be stated in the test report.
- D-M3: a test signal shall be agreed between the accredited test laboratory and the applicant in case selective messages are used and are generated or decoded within the equipment.

6.2 Artificial antenna

Where applicable, tests shall be carried out using an artificial antenna which shall be a substantially non-reactive non-radiating load with a 50 Ω impedance, connected to the antenna connector. The Voltage Standing Wave Ratio (VSWR) at the 50 Ω connector shall not be greater than 1,2: 1 over the frequency range of the measurement.

6.3 Test fixture

With equipment intended for use with an integral antenna, and not equipped with a 50 Ω RF output connector, a suitable test fixture may be used, see also subclause 4.2.3.

This fixture is a radio frequency device for coupling the integral antenna to a 50 Ω RF terminal at the working frequencies of the equipment under test. This allows certain measurements to be performed using conducted measuring methods. However, only relative measurements may be performed.

The test fixture shall be fully described by the applicant. The test laboratory shall calibrate the test fixture by carrying out the required field measurements at normal temperatures at the prescribed test site. Then the same measurements shall be repeated on the equipment under test using the test fixture for all identified frequency components.

In addition, the test fixture may provide:

- a connection to an external power supply;
- an audio interface either by direct connection or by an acoustic coupler;
- a connection to an analogue or a data interface.

The performance characteristics of the test fixture shall to the following basic parameters:

- the circuit associated with the RF coupling shall contain no active or non linear devices;
- the coupling loss shall not influence the measuring results;
- the coupling loss shall be independent of the position of the test fixture and be unaffected by the proximity of the surrounding objects or people;
- the coupling loss shall be reproducible when the equipment under test is removed and replaced;
- the coupling loss shall remain substantially constant when the environmental conditions are varied.

6.4 Test sites and general arrangements for radiated measurements

For guidance on radiation test sites, see Annex A. Detailed descriptions of radiated measurement arrangements are included in this Annex.

6.5 Measuring receiver

The term "measuring receiver" refers to a selective voltmeter or a spectrum analyser. The bandwidth of the measuring receiver shall be as given in table 3.

Table 3

Frequency: (f)	Measuring receiver bandwidth
$30 \text{ MHz} \leq f \leq 1\,000 \text{ MHz}$	120 kHz
$f > 1\,000 \text{ MHz}$	1 MHz

7 Methods of measurement and limits for transmitter parameters

Where the transmitter is designed with adjustable carrier power, then all transmitter parameters shall be measured using the highest power level, as declared by the applicant. The equipment shall then be set to the lowest carrier power setting, as declared by the applicant, and the measurements for spurious emissions shall be repeated (see subclause 7.3).

When making transmitter tests on equipment designed for intermittent operation, the duty cycle of the transmitter, as declared by the applicant, shall not be exceeded. The actual duty cycle used shall be recorded and stated in the test report.

NOTE: The maximum duty cycle of the transmitter under test should not be confused with the duty cycle of the equipment under normal operating conditions.

When performing transmitter tests on equipment designed for intermittent operation it may be necessary to exceed the duty cycle associated with normal operation. Where this is the case, care should be taken to avoid heating effects having an adverse effect on the equipment and the parameters being measured. The maximum transmit-on time shall be decided by the applicant and where applicable the accredited test laboratory, this time shall not be exceeded and details shall be stated in the test report.

If the equipment to be tested is designed with a permanent external 50 Ω RF connector and a dedicated or integral antenna, then full tests shall be carried out using this connector. If the RF connector is not 50 Ω a calibrated coupler or attenuator shall be used to provide the correct termination impedance, to facilitate the measurements. The equivalent isotropically radiated power is then calculated from the declared antenna gain.

In addition, the following tests shall be carried out with the dedicated or integrated antenna:

- effective radiated power (radiated) see subclause 7.1;
- spurious emissions (see subclause 7.3).

The equipment shall fulfil the requirements of the stated measurements.

7.1 Equivalent isotropically radiated power (eirp)

7.1.1 Definition

The eirp is defined as the peak power of the transmitter and calculated according to the procedure given in the following subclause. See clause 5 for the test conditions.

7.1.2 Method of measurement

Using the applicable measurement procedure as described in Annex B, the power output shall be measured and recorded in the test report. The method of measurement shall be documented in the test report.

In order to measure eirp it is first necessary to determine the appropriate method of measurement to be used, see subclauses 7.1.2.1 and 7.1.2.2. The -6dB transmitter bandwidth shall be determined using a 100 kHz measuring bandwidth in order to establish which measurement method is applicable.

7.1.2.1 Non spread spectrum transmitters with a -6 dB bandwidth up to 20 MHz

This method of measurement shall only be used for:

- non spread spectrum equipment with a -6 dB bandwidth of 20 MHz or less and a duty cycle above 50 %;
- spread spectrum equipment with a -6 dB channel bandwidth of 1 MHz or less.

Other transmitters are tested according to subclause 7.1.2.2.

The equipment shall be able to operate in a continuous transmit mode for testing purposes, where possible.

For FHSS systems, the hop frequency which provides the maximum indicated level shall be used. The frequency shall be indicated in the test report.

For peak power measurements, a spectrum analyser or selective voltmeter shall be used and tuned to the transmitter carrier at which the highest level is detected.

The measurement shall be made using a test signal, see subclause 6.1.

Measurements shall be performed at normal and extreme conditions (see subclauses 5.3 and 5.4).

The eirp is calculated according to the relevant method stated in Annex B.

7.1.2.2 Other transmitters than defined in subclause 7.1.2.1

This method of measurement shall be used for:

- equipment with a -6 dB bandwidth greater than 20 MHz;
- equipment with a duty cycle below 50 %;
- spread spectrum equipment with a channel bandwidth above 1 MHz.

The measurement shall be performed using normal operation of the equipment with test modulation applied.

The test procedure shall be as follows:

Step 1:

- using suitable attenuators, the output power of the transmitter shall be coupled to a matched diode detector. The output of the matched diode detector shall be connected to the vertical channel of an oscilloscope;
- the combination of the matched diode detector and the oscilloscope shall be capable of faithfully reproducing the envelope peaks and the duty cycle of the transmitter output signal;
- the observed duty cycle of the transmitter ($T_x \text{ on} / (T_x \text{ on} + T_x \text{ off})$) shall be noted as x ($0 < x \leq 1$), and recorded in the test report. For the purpose of testing, the equipment shall be operated with a duty cycle that is equal to or greater than 0,1. Where this duty cycle is not possible, then this shall be stated on the test report and the actual duty cycle shall be declared.

Step 2:

- the average output power of the transmitter shall be determined using a wideband calibrated RF power meter with a matched thermocouple detector or an equivalent thereof and with an integration period that exceeds the repetition period of the transmitter by a factor 5 or more. The observed value shall be noted as "A" (in dBm);
- the eirp shall be calculated from the above measured power output A (in dBm) the observed duty cycle x, and the declared antenna gain(s) "G" in dBi, according to the formula:
 - $P = A + G + 10 \log (1/x)$ (dBm).
- P, converted from dBm into mW, shall not exceed the value specified in table 4, and shall be recorded in the test report.

Step 3:

- the measurement set up as given under step 1 shall be used to determine, on the oscilloscope, the peak of the envelope of the output signal of the transmitter;
- the maximum (peak) deviation of the Y-trace of the oscilloscope shall be noted as "B".

Step 4:

- the transmitter shall be replaced by a signal generator. The output frequency of the signal shall be made equal to the centre of the frequency range occupied by the transmitter;
- the signal generator shall be unmodulated. The output power of the signal generator shall be raised to a level such that the deviation of the Y-trace of the oscilloscope reaches level B, as indicated in step 3;
- this output level "C" (in dBm) of the signal generator shall be determined using a wideband, calibrated RF power meter with a matched thermocouple detector or an equivalent thereof;
- level C shall not exceed by more than 3 dB the value specified in table 4, converted into dBm, minus the antenna gain(s) G in dBi;
- the measurement shall be repeated at the lowest, the middle, and the highest frequency of the declared frequency range. These frequencies shall be recorded in the test report.

Measurements shall be performed at normal and extreme conditions (see subclauses 5.3 and 5.4).

7.1.3 Limits

The transmitter maximum eirp under normal and extreme test conditions shall not exceed the values given in table 4.

Table 4: Maximum radiated peak power (eirp)

Power Class	Power level (conducted or radiated)
8	10 mW
9	25 mW
11	100 mW
12	500 mW
13	1 W
14	2 W
14a	4 W
NOTE: Class designation is based on CEPT/ERC Recommendation 70-03 [3]	

For equipment with an integral antenna and no RF connector, measurements under extreme conditions are not required.

7.2 Permitted range of operating frequencies

The frequency range of the equipment is determined by the lowest and highest frequencies occupied by the power envelope in accordance with CEPT/ERC Recommendation 74-01 [8].

f_H is the highest frequency of the power envelope, it is the frequency furthest above the frequency of maximum power where the output power drops below the level of $-74,8$ dBm/Hz spectral power density (-30 dBm if measured in a 30 kHz reference bandwidth) eirp.

f_L is the lowest frequency of the power envelope; it is the frequency furthest below the frequency of maximum power where the output power drops below the level of $-74,8$ dBm/Hz spectral power density (-30 dBm if measured in a 30 kHz reference bandwidth) eirp.

7.2.1 Definition

The permitted range of operating frequencies includes all frequencies on which the equipment may operate within an assigned frequency band. The operating frequency range shall be declared by the manufacturer.

The range of frequencies, determined by subclause 7.2, shall be specified in the test report.

7.2.2 Method of measurement

The method of measurement for equipment employing FHSS modulation is given in subclause 7.2.3.

Using applicable conducted measurement procedures, as described in Annex B, the frequency range(s) shall be measured and recorded in the test report.

During these measurements the test data sequence as specified in subclauses 6.1 and 6.1.1 shall be used. The transmitter power level shall be set to the rated power level.

These measurements shall be performed under both normal and extreme operating conditions.

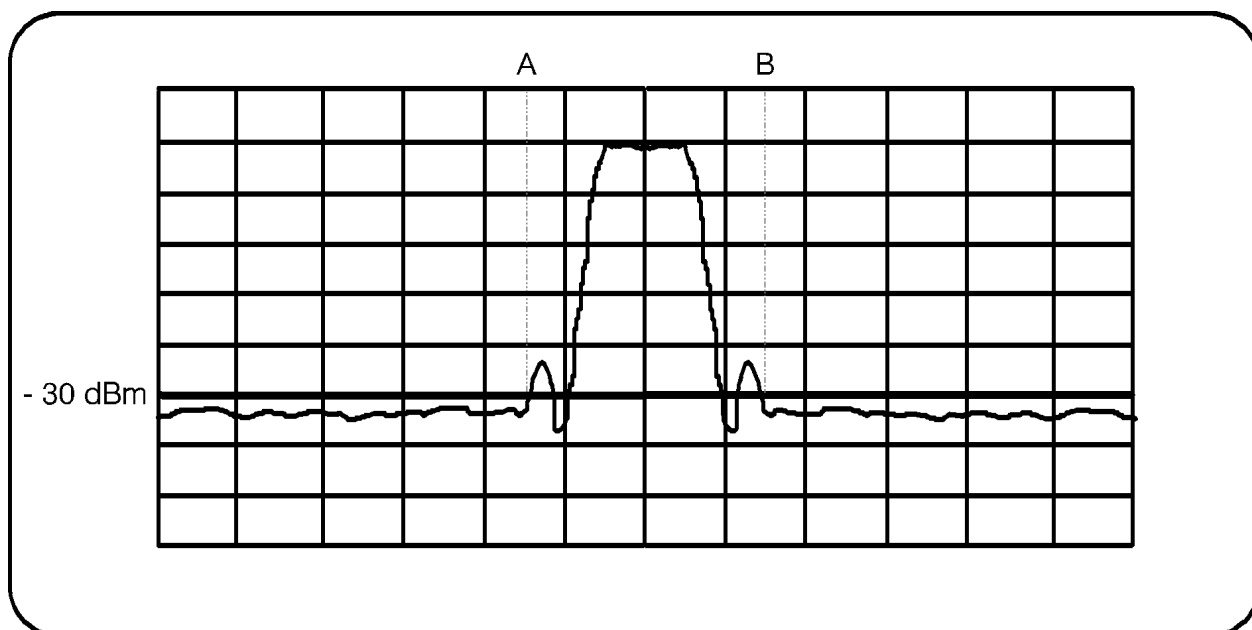

Figure 1: Measuring the extreme frequencies of the power envelope

The measurement procedure shall be as follows:

- a) put the spectrum analyser in video averaging mode with a minimum of 50 sweeps selected;
- b) select the lowest operating frequency of the equipment under test and activate the transmitter with modulation applied. The RF emission of the equipment shall be displayed on the spectrum analyser. The display will form an image like that shown in figure 1;
- c) using the marker of the spectrum analyser, find lowest frequency below the operating frequency at which spectral power density drops below the level given in subclause 7.2 (see A in figure 1). This frequency shall be recorded in the test report;
- d) select the highest operating frequency of the equipment under test and find the highest frequency at which the spectral power density drops below the value given in subclause 7.2 (see B in figure 1). This frequency shall be recorded in the test report;
- e) the difference between the frequencies measured in steps c) and d) is the operating frequency range. It shall be recorded in the test report.

This measurement shall be repeated for each frequency range declared by the manufacturer.

7.2.3 Method of measurement for equipment using FHSS modulation

Using an applicable conducted measurement procedure as described in Annex B the frequency range of the equipment shall be measured and recorded in the test report.

During these measurements the test data sequence, as specified in subclause 6.1, shall be used.

The transmitter power level shall be set to the rated power level.

These measurements shall be performed under both normal and extreme operating conditions.

The measurement procedure shall be as follows:

- a) put the spectrum analyser in video averaging mode with a minimum of 50 sweeps selected;
- b) select the lowest hop frequency of the equipment under test and activate the transmitter with modulation applied. The display will form an image similar to that shown in figure 1;
- c) find the lowest frequency below the operating frequency at which spectral power density drops below the level given in subclause 7.2 (see A in figure 1). This frequency shall be recorded in the test report;
- d) select the highest hop frequency of the equipment under test and find the highest frequency at which the spectral power density drops below the level given in subclause 7.2 (see B in figure 1). This frequency shall be recorded in the test report;
- e) the difference between the frequencies measured in steps c) and d) is the frequency range. It shall be recorded in the test report.

This measurement shall be repeated for each operating frequency range declared by the manufacturer.

7.2.4 Limit

The width of the power envelope is $f_H - f_L$ for a given operating frequency. In equipment that allows adjustment or selection of different operating frequencies, the power envelope takes up different positions in the allowed band. The frequency range is determined by the lowest value of f_L and the highest value of f_H resulting from the adjustment of the equipment to the lowest and highest operating frequencies.

For all equipment the frequency range shall lie within the frequency band allocated for use as recommended in CEPT/ERC Recommendation 70-03 [3]. For non-harmonized frequency bands the available frequency range may differ between national administrations.

7.3 Spurious emissions

7.3.1 Definition

Spurious emissions are emissions at frequencies, other than those of the carrier and sidebands associated with normal modulation. The level of spurious emissions shall be measured as either:

- a)
 - i) their power level in a specified load (conducted emission); and
 - ii) their effective radiated power when radiated by the cabinet and structure of the equipment (cabinet radiation);
or
- b) their effective radiated power when radiated by the cabinet and the integral or dedicated antenna, in the case of equipment fitted with such an antenna and no permanent RF connector.

7.3.2 Measuring receiver

The term "measuring receiver" refers to either a selective voltmeter or spectrum analyser. The bandwidth of the measuring receiver shall, where possible, be according to CISPR 16-1 [4]. In order to obtain the required sensitivity a narrower bandwidth may be necessary, this shall be stated in the test report form. The maximum bandwidth of the measuring receiver is given in table 5.

Table 5: Measuring receiver bandwidths

Frequency being measured (f)	Measuring receiver bandwidth
$f < 1\ 000\ \text{MHz}$	100 kHz to 120 kHz
$f \geq 1\ 000\ \text{MHz}$	1 MHz

7.3.3 Method of measurement conducted spurious emission

This method of measurement applies to transmitters having a permanent antenna connector.

Additional requirements for equipment employing FHSS modulation are given in subclause 7.3.6.

- a) The transmitter shall be connected to a measuring receiver through a test load, 50 Ω power attenuator, and if necessary, an appropriate filter to avoid overloading of the measuring receiver. The bandwidth of the measuring receiver shall be adjusted until the sensitivity of the measuring receiver is at least 6 dB below the spurious emission limit given in table 6, see subclause 7.3.7. This bandwidth shall be recorded in the test report.

For the measurement of spurious emissions below the second harmonic of the carrier frequency the filter used shall be a high "Q" (notch) filter centred on the transmitter carrier frequency and attenuating this signal by at least 30 dB.

For the measurement of spurious emissions at and above the second harmonic of the carrier frequency the filter used shall be a high pass filter with a stop band rejection exceeding 40 dB. The cut-off frequency of the high pass filter shall be approximately 1,5 times the transmitter carrier frequency.

Precautions may be required to ensure that the test load does not generate or that the high pass filter does not attenuate, the harmonics of the carrier.

- b) The transmitter shall be unmodulated and operating at the maximum limit of its specified power range. If modulation cannot be inhibited then the test shall be carried out with modulation (see subclause 6.1) and this fact shall be recorded in the test report.

- c) For carrier frequencies in the range 1 GHz to 20 GHz the frequency of the measuring receiver shall be adjusted over the frequency range 25 MHz to 10 times the carrier frequency, not exceeding 40 GHz. For carrier frequencies above 20 GHz the measuring receiver shall be tuned over the range 25 MHz up to twice the carrier frequency. The frequency and level of every spurious emission found shall be noted. The emissions within the channel occupied by the transmitter carrier and, for channelized systems its adjacent channels, shall not be recorded.
- d) If the measuring receiver has not been calibrated in terms of power level at the transmitter output, the level of any detected components shall be determined by replacing the transmitter by the signal generator and adjusting it to reproduce the frequency and level of every spurious emission noted in step c). The absolute power level of each of the emissions shall be noted.
- e) The frequency and level of each spurious emission measured and the bandwidth of the measuring receiver shall be recorded in the test report.
- f) If a user accessible power adjustment is provided then the tests in steps c) to e) shall be repeated at the lowest power setting available.
- g) The measurement in steps c) to f) shall be repeated with the transmitter in the standby condition if this option is available.

7.3.4 Method of measurement cabinet spurious radiation

This method of measurement applies to transmitters having a permanent antenna connector. For equipment without a permanent antenna connector see subclause 7.3.5.

Additional requirements for equipment employing FHSS modulation are given in subclause 7.3.6.

- a) A test site selected from Annex A which fulfils the requirements of the specified frequency range of this measurement shall be used. The test antenna shall be oriented initially for vertical polarization and connected to a measuring receiver. The bandwidth of the measuring receiver shall be adjusted until the sensitivity of the measuring receiver is at least 6 dB below the spurious emission limit given in table 6, see subclause 7.3.7. This bandwidth shall be recorded in the test report.

The transmitter under test shall be placed on the support in its standard position, connected to an artificial antenna (see subclause 6.2) and switched on without modulation. If modulation cannot be inhibited then the test shall be carried out with modulation, (see subclause 6.1), and this fact shall be recorded in the test report.

- b) For carrier frequencies in the range 1 GHz to 20 GHz the frequency of the measuring receiver shall be adjusted over the frequency range 25 MHz to 10 times the carrier frequency, not exceeding 40 GHz. For carrier frequencies above 20 GHz the measuring receiver shall be tuned over the range 25 MHz up to twice the carrier frequency, except for the channel on which the transmitter is intended to operate and for channelized systems, its adjacent channels. The frequency of each spurious emission detected shall be noted. If the test site is disturbed by interference coming from outside the site, this qualitative search may be performed in a screened room, with a reduced distance between the transmitter and the test antenna.
- c) At each frequency at which a emission has been detected, the measuring receiver shall be tuned and the test antenna shall be raised or lowered through the specified height range until the maximum signal level is detected on the measuring receiver.
- d) The transmitter shall be rotated through 360° about a vertical axis, to maximize the received signal.
- e) The test antenna shall be raised or lowered again through the specified height range until a maximum is obtained. This level shall be noted.
- f) The substitution antenna (see subclause A.2.3) shall replace the transmitter antenna in the same position and in vertical polarization. It shall be connected to the signal generator.

- g) At each frequency at which a emission has been detected, the signal generator, substitution antenna, and measuring receiver shall be tuned. The test antenna shall be raised or lowered through the specified height range until the maximum signal level is detected on the measuring receiver. The level of the signal generator giving the same signal level on the measuring receiver as in item e) shall be noted. After corrections due to the gain of the substitution antenna and the cable loss between the signal generator and the substitution antenna, is the radiated spurious emission at this frequency.
- h) The frequency and level of each spurious emission measured and the bandwidth of the measuring receiver shall be recorded in the test report.
- i) Steps c) to h) shall be repeated with the test antenna oriented in horizontal polarization.
- j) If a user accessible power adjustment is provided then the tests in steps c) to h) shall be repeated at the lowest power setting available.
- k) Steps c) to i) shall be repeated with the transmitter in the standby condition if this option is available.

7.3.5 Method of measurement radiated spurious emission

This method of measurement applies to transmitters having an integral antenna.

Additional requirements for equipment employing FHSS modulation are given in subclause 7.3.6.

- a) A test site selected from Annex A which fulfils the requirements of the specified frequency range of this measurement shall be used. The test antenna shall be oriented initially for vertical polarization and connected to a measuring receiver, through a suitable filter to avoid overloading of the measuring receiver if required. The bandwidth of the measuring receiver shall be adjusted until the sensitivity of the measuring receiver is at least 6 dB below the spurious emission limit given in table 6, see subclause 7.3.7. This bandwidth shall be recorded in the test report.

For the measurement of spurious emissions below the second harmonic of the carrier frequency the optional filter used shall be a high "Q" (notch) filter centred on the transmitter carrier frequency and attenuating this signal by at least 30 dB.

For the measurement of spurious emissions at and above the second harmonic of the carrier frequency the optional filter used shall be a high pass filter with a stop band rejection exceeding 40 dB. The cut-off frequency of the high pass filter shall be approximately 1,5 times the transmitter carrier frequency.

The transmitter under test shall be placed on the support in its standard position and shall be switched on without modulation. If modulation cannot be inhibited then the test shall be carried out with modulation (see subclause 6.1) and this fact shall be recorded in the test report.

- b) The same method of measurement as steps b) and k) of subclause 7.3.4 shall be used.

7.3.6 Additional requirements for equipment employing FHSS modulation

Measurements shall be carried out while the equipment is hopping between two frequencies separated by the maximum hop frequency change declared by the manufacturer, one of which is the lowest hop frequency.

The measurements shall be repeated on two frequencies separated by the maximum hop frequency change declared by the manufacturer, one of which is the highest hop frequency.

7.3.7 Limits

The power of any spurious emission shall not exceed the following values given in table 6.

Table 6: Radiated spurious emissions

State	47 to 74 MHz 87,5 to 118 MHz 174 to 230 MHz 470 to 862 MHz	Other frequencies ≤ 1 000 MHz	Frequencies > 1 000 MHz
Operating	4 nW	250 nW	1 μW
Standby	2 nW	2 nW	20 nW

7.4 Duty cycle

7.4.1 Definitions

For the purpose of the present document the term duty cycle refers to the ratio of the total on time of the "message" to the total off-time in any one hour period. The device may be triggered either automatically or manually and depending on how the device is triggered will also depend on whether the duty cycle is fixed or random.

7.4.2 Declaration

For software controlled or pre-programmed devices, the applicant shall declare the duty cycle class or classes for the equipment under test, see table 7.

For manually operated or event dependant devices, with or without software controlled functions, the applicant shall declare whether the device once triggered, follows a pre-programmed cycle, or whether the transmission is constant until the trigger is released or manually reset. The applicant shall also give a description of the application for the device and include a typical usage pattern. The typical usage pattern as declared by the applicant shall be used to determine the duty cycle and hence the duty class, see table 7.

Where an acknowledgement is required, the additional transmitter on-time shall be included and declared by the manufacturer.

7.4.3 Duty cycle classes

In a period of 1 hour the duty cycle shall not exceed the values given in table 7.

Table 7

Duty cycle Class	Duty cycle ratio
1	< 0,1 %
2	< 1,0 %
3	< 10 %
4	Up to 100 %

7.5 Additional requirements for FHSS equipment

7.5.1 FHSS modulation

FHSS modulation shall make use of at least 20 well defined, non-overlapping channels or hopping positions separated by the channel bandwidth as measured at 20 dB below peak power. The dwell time per channel shall not exceed 0,4 s. The maximum 20 dB bandwidth of a single hop channel shall not exceed 1 MHz, when measured in a 100 kHz bandwidth. While the equipment is operating (transmitting and/or receiving) each channel of the hopping sequence shall be occupied at least once during a period not exceeding four times the product of the dwell time per hop and the number of channels.

The applicant shall declare the total number of hops, the dwell time, the bandwidth per hop and the maximum separation of hops.

7.5.2 FHSS transmit level during frequency hop

The transmit level during the frequency hop is the instantaneous power level of the transmitter during the period of time between any given pair of hop channels.

For FHSS equipment the transmitter power level shall be attenuated to below the specified transmitter standby spurious emissions level, see subclause 7.3.7, during the period of hop between frequencies. This transmitter attenuation shall be declared by the applicant.

8 Receiver

8.1 Adjacent channel selectivity-in band

This measurement is required where a frequency plan with standard channel spacing is stated.

The measurement shall not be performed if:

- a) the transmitter cannot be switched off and the spacing between the transmit and the receiver is less than ten times the declared receiver 3 dB bandwidth; or
- b) the transmitter and receiver are operating at the same frequency and the transmitter cannot be switched off as the carrier is used as receiver injection signal.(e.g., for homodyne systems).

In the case where a) and/or b) above applies, this shall be stated in the test report.

8.1.1 Definition

The adjacent channel selectivity is a measure of the capability of the receiver to operate satisfactorily in the presence of an unwanted signal that differs in frequency from the wanted signal by an amount equal to the adjacent channel separation for which the equipment is intended.

8.1.2 Method of measurement

This measurement shall be conducted under normal conditions.

Two signal generators A and B shall be connected to the receiver via a combining network to the receiver, either:

- via a test fixture or a test antenna to the receiver integrated, dedicated or test antenna; or,
- directly to the receiver permanent or temporary antenna connector.

The method of coupling to the receiver shall be stated in the test report.

Signal generator A shall be at the nominal frequency of the receiver, with normal modulation of the wanted signal. Signal generator B shall be unmodulated and shall be adjusted to the test frequency immediately above that of the wanted signal.

Initially signal generator B shall be switched off and using signal generator A the level that still gives sufficient response shall be established. The output level of generator A shall then be increased by 3 dB.

Signal generator B is then switched on and adjusted until the wanted criteria are met. This level shall be recorded.

The measurements shall be repeated immediately below the wanted signal.

The adjacent channel selectivity shall be recorded for the upper and lower adjacent channels as the level in dBm of the unwanted signal.

For tagging systems (e.g, RF identification, anti-theft, access control, location and similar systems) signal generator A may be replaced by a physical tag positioned at 70 % of the measured system range in metres. In this case, the adjacent selectivity shall be recorded as the level in dBm of lowest level of the unwanted signal (generator B).

8.1.3 Limits

The adjacent channel selectivity of the equipment under specified conditions shall not exceed the levels of the unwanted signal as stated in table 8.

Table 8

Equipment class	Channel spacing \leq 1 MHz	Channel spacing $>$ 1 MHz
1	-40 dBm	-30 dBm

8.2 Adjacent band selectivity

8.2.1 Definition

The adjacent band selectivity is a measure of the capability of the receiver to operate satisfactorily in the presence of an unwanted signal which is situated at the edge of the assigned band.

8.2.2 Method of measurement

Two signal generators A and B shall be connected to the receiver via a combining network to the receiver, either:

- via a test fixture or a test antenna to the receiver integrated, dedicated or test antenna; or,
- directly to the receiver permanent or temporary antenna connector.

The method of coupling to the receiver shall be stated in the test report.

Signal generator A shall be at the nominal frequency of the receiver, with normal modulation of the wanted signal. Signal generator B shall be unmodulated and shall be adjusted to the upper band test frequency.

Initially signal generator B shall be switched off and using signal generator A the level which still gives sufficient response shall be established. The output level of generator A shall then be increased by 3 dB.

Signal generator B is then switched on and adjusted until the wanted criteria are met. This level shall be recorded.

The measurements shall be repeated at the lower band edge.

The adjacent band selectivity shall be recorded for the upper and lower adjacent channels as level in dBm of the unwanted signal.

For tagging systems (e.g., RF identification, anti-theft, access control, location and similar systems) signal generator A may be replaced by a physical tag positioned at 70 % of the measured system range in metres. In this case, the adjacent selectivity shall be recorded as the level in dBm of lowest level of the unwanted signal (generator B).

8.2.3 Limits

The adjacent channel selectivity of the equipment under specified conditions shall not exceed the levels of the unwanted signal as stated in table 9.

Table 9

Equipment class	At band edge
1	-30 dBm

8.3 Blocking or desensitization

8.3.1 Definition

Blocking is a measure of the capability of the receiver to receive a wanted modulated signal without exceeding a given degradation due to the presence of an unwanted input signal at any frequencies other than those of the spurious responses or the adjacent channels or bands, see subclauses 9.1 and 9.2.

8.3.2 Methods of measurement

This measurement shall be conducted under normal conditions.

Two signal generators A and B shall be connected to the receiver via a combining network to the receiver, either:

- via a test fixture or a test antenna to the receiver integrated, dedicated or test antenna; or,
- directly to the receiver permanent or temporary antenna connector.

The method of coupling to the receiver shall be stated in the test report.

Signal generator A shall be at the nominal frequency of the receiver, with normal modulation of the wanted signal. Signal generator B shall be unmodulated and shall be adjusted to a test frequency 1 to 10 MHz above that of the upper band edge.

Initially signal generator B shall be switched off and using signal generator A the level which still gives sufficient response shall be established. The output level of generator A shall then be increased by 3 dB.

Signal generator B is then switched on and adjusted until the wanted criteria are met. This level shall be recorded.

The frequency for signal generator B shall be at the following frequencies:

- a) For the frequency ranges 1 GHz to 10 GHz, the measurements shall be at approximately +5 MHz, +10 MHz, +20 MHz and +50 MHz from the upper band edge.
The tests shall be repeated at approximately -5 MHz, -10 MHz, -20 MHz and -1 MHz from the lower band edge.
- b) For the frequency ranges 10 GHz to 40 GHz, the measurements shall be at approximately +20 MHz, +50 MHz, +100 MHz and +200 MHz from the upper band edge.
The tests shall be repeated at approximately -20 MHz, -50 MHz, -100 MHz and -200 MHz from the lower band edge.

The blocking or desensitization shall be recorded as the level in dBm of lowest level of the unwanted signal (generator B).

For tagging systems (e.g., RF identification, anti-theft, access control, location and similar systems) signal generator A may be replaced by a physical tag positioned at 70 % of the measured system range in metres. In this case, the blocking or desensitization shall be recorded as the ratio in dBm of lowest level of the unwanted signal (generator B).

8.3.3 Limits

The blocking level, for any frequency within the specified ranges, shall not be less than the values given in table 10, except at frequencies on which spurious responses are found.

Table 10

Equipment Class	1 – 10 GHz		10 – 40 GHz	
	Frequency offset (MHz)	Limit	Frequency offset (MHz)	Limit
1	All	-30 dBm	All	-30 dBm
2	± 5	-50 dBm	± 20	-50 dBm
	± 10	-45 dBm	± 50	-45 dBm
	± 20	-40 dBm	± 100	-40 dBm
	± 50	-30 dBm	± 200	-30 dBm

8.4 Spurious emissions

This test is to be performed where the receiver is not combined with the transmitter and operating simultaneously.

8.4.1 Definition

Spurious radiations from the receiver are components at any frequency, radiated by the equipment and antenna.

The level of spurious radiations shall be measured by either:

- a)
 - i) their power level in a specified load (conducted spurious emission); and
 - ii) their effective radiated power when radiated by the cabinet and structure of the equipment (cabinet radiation);
or
- b) their effective radiated power when radiated by the cabinet and the integral antenna, in the case of portable equipment fitted with such an antenna and no permanent RF connector.

8.4.2 Method of measurement conducted spurious components

This method of measurement applies to receivers having a permanent antenna connector.

A test load, 50 Ω power attenuator, may be used to protect the measuring receiver (see subclause 7.3.2) against damage when testing a receiver combined in one unit with a transmitter.

The measuring receiver used shall have sufficient dynamic range and sensitivity to achieve the required measurement accuracy at the specified limit. The bandwidth of the measuring receiver shall be adjusted until the sensitivity of the measuring receiver is at least 6 dB below the spurious emission limit given in subclause 8.4.5. This bandwidth shall be recorded in the test report.

- a) The receiver input terminals shall be connected to a measuring receiver having an input impedance of 50 Ω and the receiver is switched on.
- b) For carrier frequencies in the range 1 GHz to 20 GHz the frequency of the measuring receiver shall be adjusted over the frequency range 25 MHz to 10 times the carrier frequency, not exceeding 40 GHz. For carrier frequencies above 20 GHz the measuring receiver shall be tuned over the range 25 MHz up to twice the carrier frequency. The frequency and the absolute power level of each of the spurious components found shall be noted.
- c) If the detecting device is not calibrated in terms of power input, the level of any detected components shall be determined by replacing the receiver by the signal generator and adjusting it to reproduce the frequency and level of every spurious component noted in step b). The absolute power level of each spurious component shall be noted.

- d) The frequency and level of each spurious emission measured and the bandwidth of the measuring receiver shall be recorded in the test report.

8.4.3 Method of measurement cabinet radiation

This method of measurement applies to receivers having a permanent antenna connector.

- a) A test site selected from Annex A which fulfils the requirements of the specified frequency range of this measurement shall be used. The test antenna shall be oriented initially for vertical polarization and connected to a measuring receiver. The bandwidth of the measuring receiver shall be adjusted until the sensitivity of the measuring receiver is at least 6 dB below the spurious emission limit given in subclause 8.1.5. This bandwidth shall be recorded in the test report.

The receiver under test shall be placed on the support in its standard position and connected to an artificial antenna, see subclause 6.2.

- b) For carrier frequencies in the range 1 GHz to 20 GHz the frequency of the measuring receiver shall be adjusted over the frequency range 25 MHz to 10 times the carrier frequency, not exceeding 40 GHz. For carrier frequencies above 20 GHz the measuring receiver shall be tuned over the range 25 MHz up to twice the carrier frequency. The frequency of each spurious component shall be noted. If the test site is disturbed by radiation coming from outside the site, this qualitative search may be performed in a screened room with reduced distance between the transmitter and the test antenna.
- c) At each frequency at which a component has been detected, the measuring receiver shall be tuned and the test antenna shall be raised or lowered through the specified height range until the maximum signal level is detected on the measuring receiver.
- d) The receiver shall be rotated up to 360° about a vertical axis, to maximize the received signal.
- e) The test antenna shall be raised or lowered again through the specified height range until a maximum is obtained. This level shall be noted.
- f) The substitution antenna (see subclause A.2.3) shall replace the receiver antenna in the same position and in vertical polarization. It shall be connected to the signal generator.
- g) At each frequency at which a component has been detected, the signal generator, substitution antenna and measuring receiver shall be tuned. The test antenna shall be raised or lowered through the specified height range until the maximum signal level is detected on the measuring receiver. The level of the signal generator giving the same signal level on the measuring receiver as in step e) shall be noted. This level, after correction due to the gain of the substitution antenna and the cable loss, is the radiated spurious component at this frequency.
- h) The frequency and level of each spurious emission measured and the bandwidth of the measuring receiver shall be recorded in the test report.
- i) Measurements b) to h) shall be repeated with the test antenna oriented in horizontal polarization.

8.4.4 Method of measurement radiated spurious components

This method of measurement applies to receivers having an integral antenna.

- a) A test site selected from Annex A which fulfils the requirements of the specified frequency range of this measurement shall be used. The test antenna shall be oriented initially for vertical polarization and connected to a measuring receiver. The bandwidth of the measuring receiver shall be adjusted until the sensitivity of the measuring receiver is at least 6 dB below the spurious emission limit given in subclause 8.4.5. This bandwidth shall be recorded in the test report.

The receiver under test shall be placed on the support in its standard position.

- b) The same method of measurement as items b) to i) of subclause 8.4.3 shall apply.

8.4.5 Limits

The power of any spurious emission shall not exceed 2 nW in the range 25 MHz to 1 GHz and shall not exceed 20 nW on frequencies above 1 GHz.

9 Measurement uncertainty

The interpretation of the results recorded in the test report for the measurements described in the present document shall be as follows:

- the measured value related to the corresponding limit shall be used to decide whether an equipment meets the requirements of the present document;
- the value of the measurement uncertainty for the measurement of each parameter shall be separately included in the test report;
- the value of the measurement uncertainty shall be, for each measurement, equal to or lower than the figures in table 11.

Table 11: Measurement uncertainty

Parameters	Uncertainty
RF frequency	$\pm 1 \times 10^{-7}$
RF power (conducted)	± 4 dB
Radiated emission of transmitter, valid to 80 GHz	± 6 dB
Radiated emission of receiver, valid to 80 GHz	± 6 dB
Temperature	$\pm 1^{\circ}$ C
Humidity	± 5 %

For the test methods, according to the present document the uncertainty figures shall be calculated according to the methods described in the ETR 028 [6] and shall correspond to an expansion factor (coverage factor) $k = 1,96$ or $k = 2$ (which provide confidence levels of respectively 95 % and 95,45 % in case where the distributions characterizing the actual measurement uncertainties are normal (Gaussian)).

Table 11 is based on such expansion factors.

The particular expansion factor used for the evaluation of the measurement uncertainty shall be stated.

Annex A (normative): Radiated measurements

A.1 Test sites and general arrangements for measurements involving the use of radiated fields

A.1.1 Outdoor test site

The outdoor test site shall be on a reasonably level surface or ground. A conducting ground plane of at least 5 m diameter shall be provided at one point on the site. In the middle of this ground plane, a non-conducting support, capable of rotation through 360° in the horizontal plane, shall be used to support the test sample in its standard position, at 1,5 m above the ground plane, with the exception of equipment with floor standing antenna. For this equipment, the antenna shall be raised, on a non-conducting support, 100 mm above the turntable, the point(s) of contact being consistent with normal use. The test site shall be large enough to allow the erection of a measuring or transmitting antenna at a distance of $\lambda/2$ or 3 m whichever is greater. The distance actually used shall be recorded with the results of the tests carried out on the site.

Sufficient precautions shall be taken to ensure that reflections from extraneous objects adjacent to the site do not degrade the measurements results in accordance with CISPR 16-1 [4].

Key:

- 1) equipment under test;
- 2) test antenna;
- 3) high pass filter (may not be necessary);
- 4) spectrum analyser or measuring receiver.

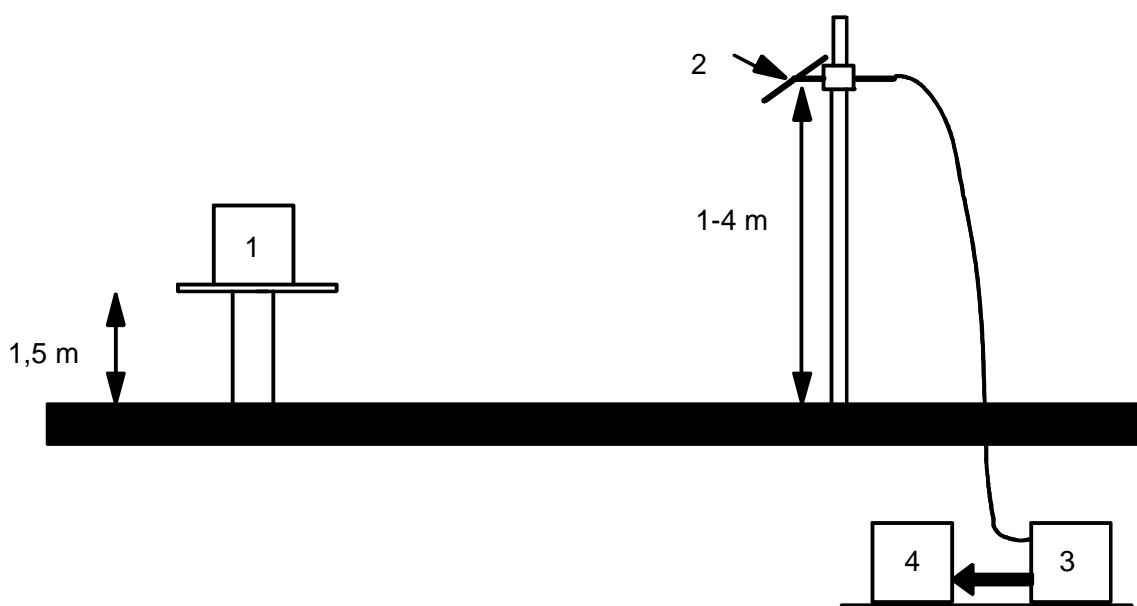

Figure A.1: Outdoor test site

A.1.1.1 Standard position

The standard position in all test sites, except for equipment which is intended to be worn on a person, shall be as follows:

- for equipment with an integral antenna, it shall be placed in the position closest to normal use as declared by the manufacturer;
- for equipment with a rigid external antenna, the antenna shall be vertical;
- for equipment with non-rigid external antenna, the antenna shall be extended vertically upwards by a non-conducting support.

A.1.2 Test antenna

The test antenna is used to detect the radiation from both the test sample and the substitution antenna, when the site is used for radiation measurements. Where necessary, it is used as a transmitting antenna, when the site is used for the measurement of receiver characteristics.

This antenna is mounted on a support such as to allow the antenna to be used in either horizontal or vertical polarization and for the height of its centre above ground to be varied over the range 1 m to 4 m. Preferably a test antenna with pronounced directivity should be used. The size of the test antenna along the measurement axis shall not exceed 20 % of the measuring distance.

For receiver and transmitter radiation measurements, the test antenna is connected to a measuring receiver, capable of being tuned to any frequency under investigation and of measuring accurately the relative levels of signals at its input.

For receiver radiated sensitivity measurements, the test antenna is connected to a signal generator.

A.1.3 Substitution antenna

When measuring in the frequency range up to 1 GHz the substitution antenna shall be a $\lambda/2$ dipole, resonant at the operating frequency, or a shortened dipole, calibrated to the $\lambda/2$ dipole. When measuring in the frequency range above 4 GHz, a horn radiator shall be used. For measurements between 1 GHz and 4 GHz either a $\lambda/2$ or a horn radiator may be used. The centre of this antenna shall coincide with the reference point of the test sample it has replaced. This reference point shall be the volume centre of the sample when its antenna is mounted inside the cabinet, or the point where an external antenna is connected to the cabinet.

The distance between the lower extremity of the dipole and the ground shall not be less than 0,3 m.

The substitution antenna shall be connected to a calibrated signal generator when the site is used for spurious radiation measurements and transmitter effective radiated power measurements. The substitution antenna shall be connected to a calibrated measuring receiver when the site is used for the measurement of receiver sensitivity.

The signal generator and the receiver shall operate at the frequencies under investigation and shall be connected to the antenna through suitable matching and balancing networks.

NOTE: The gain of a horn radiator is generally expressed relative to an isotropic radiator.

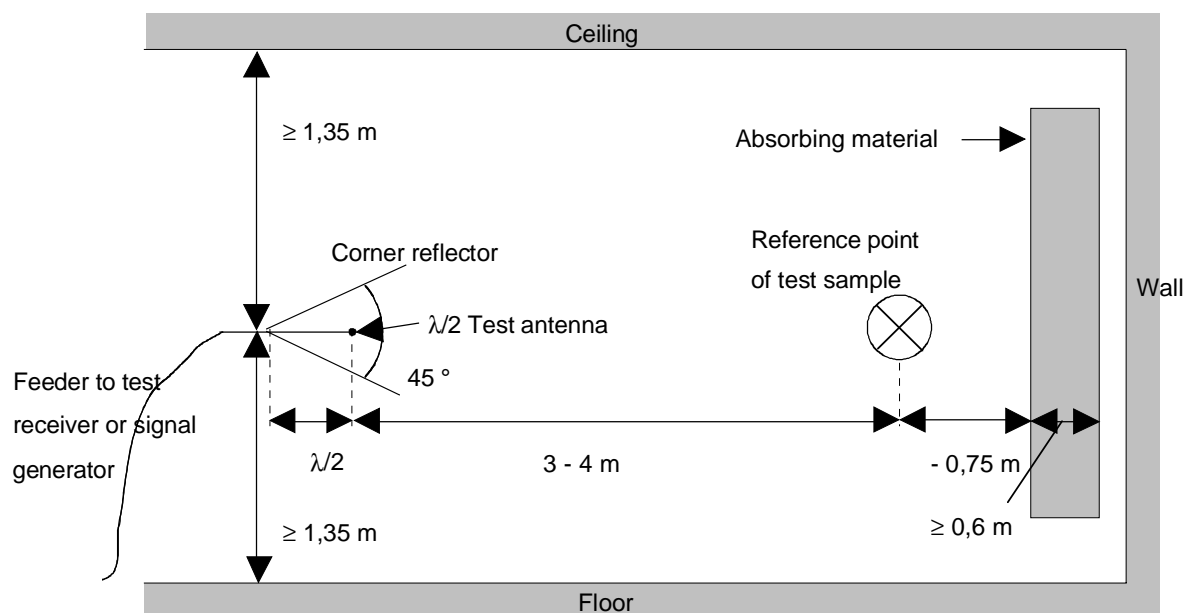

Figure A.2: Indoor site arrangement (shown for horizontal polarization)

A.1.4 Optional additional indoor site

When the frequency of the signals being measured is greater than 80 MHz, use may be made of an indoor test site. If this alternative site is used, this shall be recorded in the test report.

The measurement site may be a laboratory room with a minimum area of 6 m by 7 m and at least 2,7 m in height.

Apart from the measuring apparatus and the operator, the room shall be as free as possible from reflecting objects other than the walls, floor and ceiling.

The potential reflections from the wall behind the equipment under test are reduced by placing a barrier of absorbent material in front of it. The corner reflector around the test antenna is used to reduce the effect of reflections from the opposite wall and from the floor and ceiling, in the case of horizontally polarized measurements. Similarly, the corner reflector reduces the effects of reflections from the side walls for vertically polarized measurements. For the lower part of the frequency range (below approximately 175 MHz), no corner reflector or absorbent barrier is needed. For practical reasons, the $\lambda/2$ antenna in figure A.2 may be replaced by an antenna of constant length, provided that this length is between $\lambda/4$ and λ at the frequency of measurement, and the sensitivity of the measuring system is sufficient. In the same way, the distance of $\lambda/2$ to the apex may be varied.

The test antenna, measuring receiver, substitution antenna and calibrated signal generator are used in a way similar to that of the general method. To ensure that errors are not caused by the propagation path approaching the point at which phase cancellation between the direct and the remaining reflected signals occurs, the substitution antenna shall be moved through a distance of $\pm 0,1$ m in the direction of the test antenna as well as in the two directions perpendicular to this first direction.

If these changes of distance cause a signal change of greater than 2 dB, the test sample should be re-sited until a change of less than 2 dB is obtained.

A.2 Guidance on the use of radiation test sites

For measurements involving the use of radiated fields, use may be made of a test site in conformity with the requirements of clause A.1. When using such a test site, the following conditions should be observed to ensure consistency of measuring results.

A.2.1 Measuring distance

Evidence indicates that the measuring distance is not critical and does not significantly affect the measuring results, provided that the distance is not less than $\lambda/2$ at the frequency of measurement, and that the precautions described in this Annex are observed. Measurements at low frequencies and distances less than $\lambda/2$ are considered in the present document and shall be followed. Measuring distances of 3 m, 5 m, 10 m and 30 m are in common use in European test laboratories.

A.2.2 Test antenna

Different types of test antenna may be used, since performing substitution measurements reduces the effect of the errors on the measuring results.

Height variation of the test antenna over a range of 1 m to 4 m is essential in order to find the point at which the radiation is maximum.

Height variation of the test antenna may not be necessary at the lower frequencies below approximately 100 MHz and at higher frequencies above 1 GHz when a horn antenna is used.

A.2.3 Substitution antenna

Variations in the measuring results may occur with the use of different types of substitution antenna at the lower frequencies below approximately 80 MHz. Where a shortened dipole antenna is used at these frequencies, details of the type of antenna used should be included with the results of the tests carried out on the test site. Correction factors shall be taken into account when shortened dipole antennas are used.

A.2.4 Artificial antenna

The dimensions of the artificial antenna used during radiated measurements should be small in relation to the sample under test.

Where possible, a direct connection should be used between the artificial antenna and the test sample. In cases where it is necessary to use a connecting cable, precautions should be taken to reduce the radiation from this cable by, for example, the use of ferrite cores or double screened cables.

A.2.5 Auxiliary cables

The position of auxiliary cables (power supply and microphone cables etc.) which are not adequately de-coupled, may cause variations in the measurement results. In order to get reproducible results, cables and wires of auxiliaries should be arranged vertically downwards (through a hole in the non conducting support), or as specified in the technical documentation supplied with the equipment.

Care shall be taken to ensure that test cables do not adversely effect the measuring result.

A.3 Further optional alternative indoor test site using an anechoic chamber

For radiation measurements, when test frequency of the signals being measured is greater than 30 MHz, use may be made of an indoor test site being a well-shielded anechoic chamber simulating a free space environment. If such a chamber is used, this shall be recorded in the test report.

The test antenna, measuring receiver, substitution antenna and calibrated signal generator are used in a way similar to that of the general method, clause A.1. In the range 30 MHz to 100 MHz, some additional calibration may be necessary.

An example of a typical measurement site may be an electrically shielded anechoic chamber being 10 m long, 5 m broad and 5 m high. Walls and ceiling should be coated with RF absorbers of 1 m height. The base should be covered with absorbing material 1 m thick, and a wooden floor, able to carry test equipment and operators. A measuring distance of 3 m to 5 m in the long middle axis of the chamber can be used for measurements up to 12,75 GHz. For frequencies above 12,75 GHz the chamber may be used provided it has been calibrated for use at the frequency being measured. The construction of the anechoic chamber is described in the following subclauses.

A.3.1 Example of the construction of a shielded anechoic chamber

Free-field measurements can be simulated in a shielded measuring chamber where the walls are coated with RF absorbers. Figure A.3 shows the requirements for shielding loss and wall return loss of such a room. As dimensions and characteristics of usual absorber materials are critical below 100 MHz (height of absorbers < 1 m, reflection attenuation < 20 dB) such a room is more suitable for measurements above 100 MHz. Figure A.4 shows the construction of an anechoic shielded measuring chamber having a base area of 5 m by 10 m and a height of 5 m.

Ceilings and walls are coated with pyramidal formed RF absorbers approximately 1 m high. The base is covered with absorbers forming a non-conducting sub-floor or with special ground floor absorbers. The available internal dimensions of the room are 3 m × 8 m × 3 m, so that a maximum measuring distance of 5 m length in the middle axis of this room is available.

At 100 MHz the measuring distance can be extended up to a maximum of 2λ .

The floor absorbers reduce floor reflections so that the antenna height need not be changed and floor reflection influences need not be considered.

All measuring results can therefore be checked with simple calculations and the measurement uncertainties have the smallest possible values due to the simple measuring configuration.

A.3.2 Influence of parasitic reflections in anechoic chambers

For free-space propagation in the far field condition the correlation $E = E_0 (R_0/R)$ is valid for the dependence of the field strength E on the distance R , whereby E_0 is the reference field strength in the reference distance R_0 .

It is useful to use this correlation for comparison measurements, as all constants are eliminated with the ratio and neither cable attenuation, nor antenna mismatch, or antenna dimensions are of importance.

Deviations from the ideal curve can be seen easily if the logarithm of the above equation is used, because the ideal correlation of field strength and distance can then be shown as a straight line and the deviations occurring in practice are clearly visible. This indirect method more readily shows the disturbances due to reflections and is far less problematical than the direct measurement of reflection attenuation.

With an anechoic chamber of the dimensions suggested in clause A.3 at low frequencies up to 100 MHz there are no far field conditions, and therefore reflections are stronger so that careful calibration is necessary. In the medium frequency range from 100 MHz to 1 GHz the dependence of the field strength on the distance meets the expectations very well. In the frequency range of 1 to 80 GHz, because more reflections occur, the dependence of the field strength on the distance does not correlate so closely.

A.3.3 Calibration of the shielded RF anechoic chamber

Careful calibration of the chamber shall be performed over the range 30 MHz to 80 GHz.

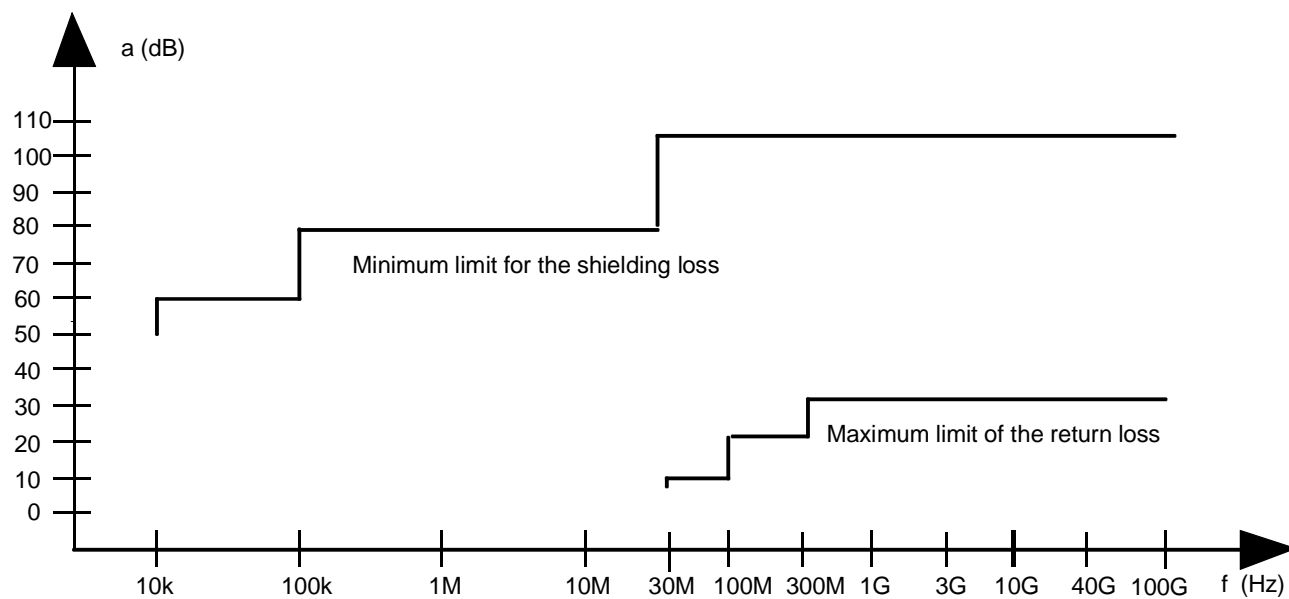
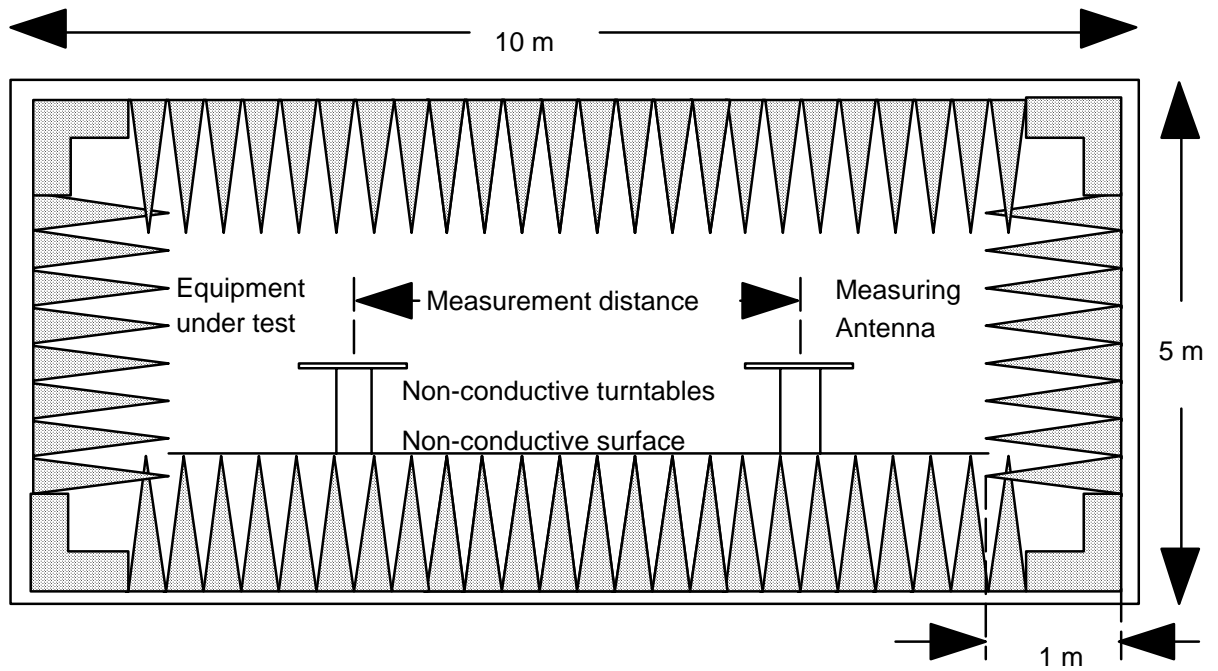

Figure A.3: Specification for shielding and reflections



Ground plan

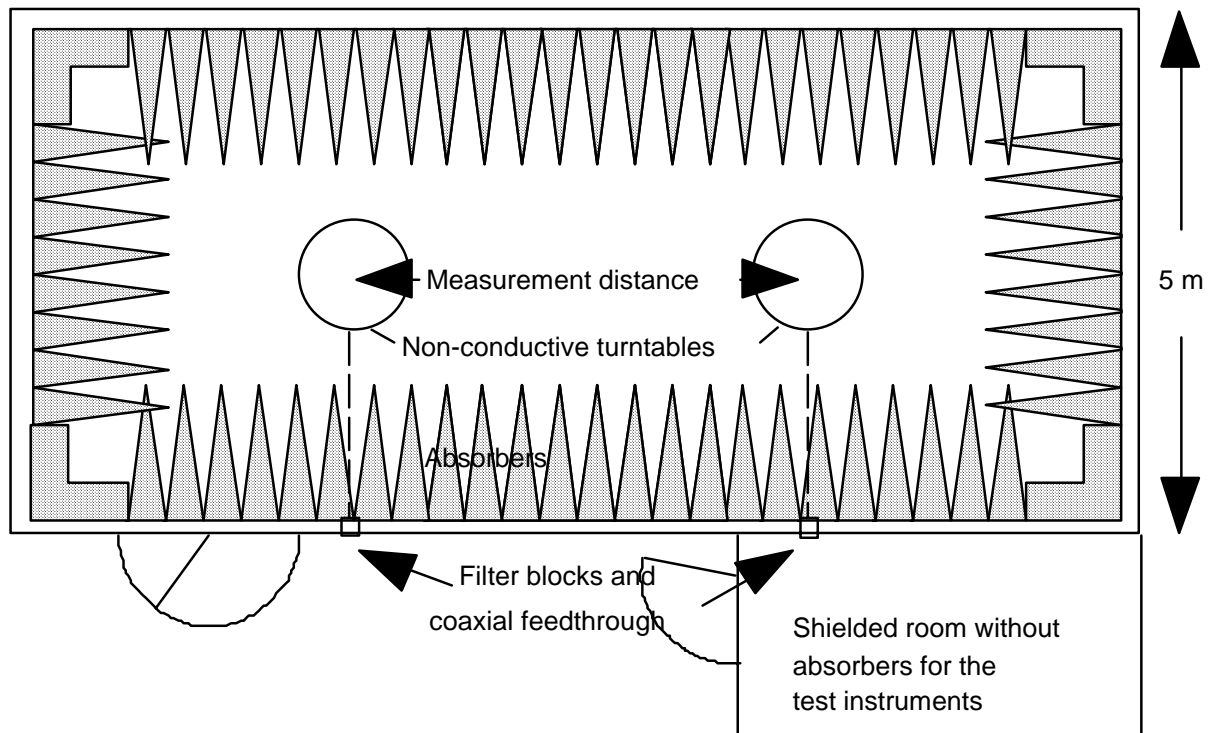

Figure A.4: Example of construction of an anechoic shielded chamber

Annex B (normative): General description of measurement methods

This Annex gives the general methods of measurements for RF signals using the test sites and arrangements described in Annex A. In addition, this Annex gives a simple measurement method for radiated emissions based on a calculated rather than measured path loss.

B.1 Conducted measurements

In view of the low power levels of the equipment to be tested under the present document, conducted measurements may be applied to equipment provided with an antenna connector. Where the equipment to be tested does not provide a suitable termination, a coupler or attenuator that does provide the correct termination value shall be used.

The equivalent isotropically radiated power is then calculated from the measured value, the known antenna gain, relative to an isotropic antenna, and if applicable, any losses due to cables and connectors in the measurement system.

B.2 Radiated measurements

Radiated measurements shall be performed with the aid of a test antenna and measurement receiver as described in Annex A. The test antenna and measurement receiver, spectrum analyser or selective voltmeter, shall be calibrated according to the procedure defined in this Annex. The equipment to be measured and the test antenna shall be oriented to obtain the maximum emitted power level. This position shall be recorded in the measurement report. The frequency range shall be measured in this position.

Preferably, radiated measurements shall be performed in an anechoic chamber. For other test sites corrections may be needed (see Annex A).

- a) A test site which fulfils the requirements of the specified frequency range of this measurement shall be used.
- b) The transmitter under test shall be placed on the support in its standard position (subclause A.1.2) and switched on.
- c) The test antenna shall be oriented initially for vertical polarization unless otherwise stated. The test antenna shall be raised or lowered, through the specified height range until the maximum signal level is detected on the measuring receiver.

The test antenna need not be raised or lowered if the measurement is carried out on a test site according to clause A.3.

- d) The transmitter shall be rotated through 360° about a vertical axis to maximize the received signal.
- e) The test antenna shall be raised or lowered again, if necessary, through the specified height range until a maximum is obtained. This level shall be recorded.

(This maximum may be a lower value than the value obtainable at heights outside the specified limits).
- f) This measurement shall be repeated for horizontal polarization.
- g) The substitution antenna, shall replace the transmitter antenna in the same position and in vertical polarization. The frequency of the signal generator shall be adjusted to the transmitter (carrier) frequency.
- h) Steps c) to f) shall be repeated.
- i) The input signal to the substitution antenna shall be adjusted in level until an equal or a known related level to that detected from the transmitter is obtained in the test receiver.

- j) This measurement shall be repeated with horizontal polarization.
- k) The radiated power is equal to the power supplied by the signal generator, increased by the known relationship if necessary and after corrections due to the gain of the substitution antenna and the cable loss between the signal generator and the substitution antenna.

Annex C (normative): Transmitter spectrum mask for RFID systems operating in the 2,45 GHz ISM band

The present document allows spectrum mask measurements to be made for RF ID systems. The measurements and limits may be relevant for RFID systems operating in the 2,45 GHz ISM band.

The spectrum mask shall be declared by the applicant and shall comply with the limits in table 4.

The parameters for RFID equipment operating in the 2,45 GHz band are defined in table C.1:

Table C.1: Parameters for 2,45 GHz RFID systems

Frequency band	Power limit, e.i.r.p. (Note)	Use of equipment	Comments
2 446 MHz to 2 454 MHz	+27 dBm	In and outdoor	FHSS or DSSS only
2 446 MHz to 2 454 MHz	+36 dBm	Indoor only	FHSS only
2 446 MHz to 2 447 MHz 2 453 MHz to 2 454 MHz	+27 dBm	In and outdoor	Unmodulated carrier (CW) only

NOTE: eirp including an antenna with the following data:

- minimum +6 dBi antenna gain;
- maximum 90 degrees horizontal beamwidth;
- 15 dB sidelobe attenuation.

The radiated spectrum shall be restricted inside the spectrum mask shown in figure C.1:

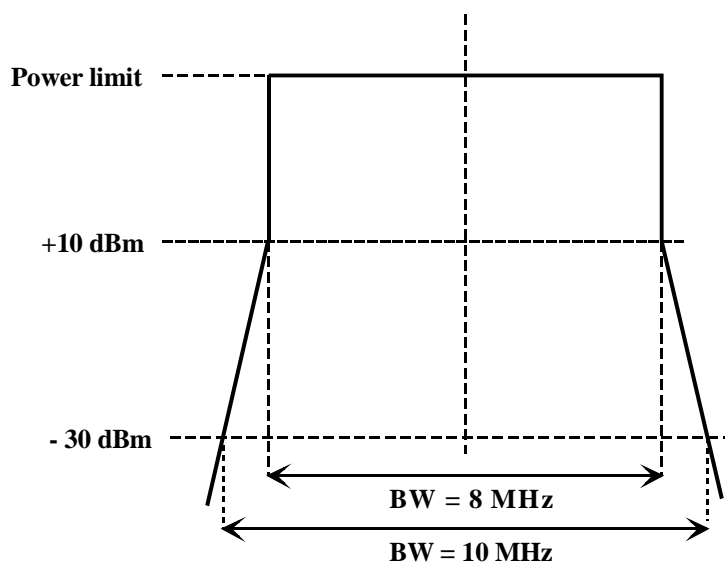

Figure C.1: Spectrum mask for RFID systems operating in the 2,45 GHz band

Bibliography

The following material, though not specifically referenced in the body of the present document (or not publicly available), gives supporting information.

- Council Directive 89/336/EEC of 3 May 1989 on the approximation of the laws of the Member States relating to electromagnetic compatibility.
- Directive 98/34/EC of the European Parliament and of the Council of 22 June 1998 laying down a procedure for the provision of information in the field of technical standards and regulations.

History

Document history		
Edition 1	December 1995	Publication as I-ETS 300 440
V1.2.1	April 1999	Public Enquiry as EN 300 440 PE 9934: 1999-04-23 to 1999-08-20
V1.3.1	July 2000	Public Enquiry PE 20001117: 2000-07-19 to 2000-11-17