

Draft **EN 300 417-7-1** V1.1.1 (1999-06)

---

*European Standard (Telecommunications series)*

**Transmission and Multiplexing (TM);  
Generic requirements of transport functionality of equipment;  
Part 7-1: Equipment management  
and auxiliary layer functions**

---



---

**Reference**

DEN/TM-01015-7-1 (3v1r9ico.PDF)

---

**Keywords**

management, SDH, PDH, transmission

**ETSI**

---

**Postal address**

F-06921 Sophia Antipolis Cedex - FRANCE

---

**Office address**

650 Route des Lucioles - Sophia Antipolis  
Valbonne - FRANCE  
Tel.: +33 4 92 94 42 00 Fax: +33 4 93 65 47 16  
Siret N° 348 623 562 00017 - NAF 742 C  
Association à but non lucratif enregistrée à la  
Sous-Préfecture de Grasse (06) N° 7803/88

---

**Internet**

secretariat@etsi.fr  
Individual copies of this ETSI deliverable  
can be downloaded from  
<http://www.etsi.org>  
If you find errors in the present document, send your  
comment to: editor@etsi.fr

---

**Copyright Notification**

No part may be reproduced except as authorized by written permission.  
The copyright and the foregoing restriction extend to reproduction in all media.

© European Telecommunications Standards Institute 1999.  
All rights reserved.

# Contents

Intellectual Property Rights .....	6
Foreword .....	6
Introduction .....	7
1 Scope .....	8
2 References .....	8
3 Definitions, abbreviations and symbols .....	9
3.1 Definitions .....	9
3.2 Abbreviations .....	9
3.3 Symbols and Diagrammatic Conventions .....	14
4 Equipment management function .....	14
4.1 Network Element - Real Time Clock (NE-RTC) Function .....	15
4.2 Fault Management Functions .....	16
4.2.1 Failure filter f4 .....	16
4.2.2 Severity assignment filter f5 .....	17
4.2.3 Replaceable unit alarm filter f6 .....	17
4.2.4 Network element alarm filter f7 .....	17
4.2.5 Station alarm filter f8 .....	17
4.3 Management Application Functions .....	17
4.4 Performance Monitoring Functions .....	18
4.4.1 Performance monitoring clock function PMC .....	20
4.4.2 Performance monitoring events functions .....	21
4.4.2.1 Near-end performance monitoring event function (NPME) .....	21
4.4.2.2 Far-end performance monitoring event function (FPME) .....	23
4.4.2.3 Uni-directional availability filter function (AvFu) .....	25
4.4.2.4 Bi-directional availability filter function (AvFb) .....	26
4.4.2.5 Delay filter function (Delay) .....	27
4.4.3 Performance monitoring history functions .....	28
4.4.3.1 Current 15m register function .....	28
4.4.3.2 Recent 15m register function .....	30
4.4.3.3 Current 24h register function .....	31
4.4.3.4 Recent 24h register function .....	33
4.4.3.5 Begin/End of UAT event generation function .....	34
4.4.3.6 CSES log function .....	34
4.4.4 Performance monitoring thresholding functions .....	36
4.4.4.1 Single level thresholding function (ThrFs) .....	37
4.4.4.2 Dual level thresholding function (ThrFd) .....	38
4.4.5 Performance monitoring packages .....	40
4.4.5.1 ITU-T Recommendations M.2100/M.2101.1 Near-end (A/Z direction) maintenance (uni-directional) package .....	41
4.4.5.2 ITU-T Recommendations M.2100/M.2101.1 far-end (Z/A direction) maintenance (uni-directional) package .....	42
4.4.5.3 ITU-T Recommendation G.826 error performance (bi-directional) package at trail termination .....	43
4.4.5.4 ITU-T Recommendation G.826 error performance (bi-directional) package at intermediate node along the trail .....	44
4.4.5.5 Pointer Justification Event package .....	45
4.5 Configuration Management Functions .....	45
4.5.1 Network element configuration .....	46
4.5.2 Protection switching provisioning .....	46
4.5.2.1 Linear STM-N MS protection .....	46
4.5.2.2 STM-N MS SPring protection .....	47
4.5.2.3 Linear 1+1 SNC protection .....	47
4.5.2.4 Linear 1+1 VC Trail protection .....	47
4.5.3 Protection switching status and control .....	48

4.5.3.1	Linear STM-N MS protection .....	48
4.5.3.2	STM-N MS SPring protection .....	48
4.5.3.3	Linear 1+1 SNC protection.....	48
4.5.3.4	Linear 1+1 VC Trail protection.....	49
4.5.4	Trace identifier processes provisioning and reporting .....	49
4.5.5	Payload structures provisioning and reporting .....	50
4.5.6	Multiplex structures provisioning and reporting .....	50
4.5.6.1	AUG provisioning .....	50
4.5.6.2	AUG autonomous adaptation.....	51
4.5.6.3	AUG reporting.....	51
4.5.6.4	TUG provisioning.....	51
4.5.6.5	TUG reporting .....	51
4.5.7	Matrix connections provisioning.....	51
4.5.8	DEG thresholds setting.....	54
4.5.9	Port mode, Termination Point mode provisioning .....	54
4.5.10	Access Point mode provisioning .....	54
4.5.11	Defect reporting provisioning .....	54
4.5.12	2 Mbit/s multiframe alignment provisioning .....	55
4.5.13	Network element synchronization provisioning .....	55
4.5.13.1	Quality Level mode provisioning .....	55
4.5.13.2	Timing Marker mode provisioning .....	55
4.5.13.3	SSM and TM support provisioning .....	55
4.5.13.4	SSM and TM disabling provisioning.....	56
4.5.13.5	Qloverwrite and QfixedValue provisioning.....	56
4.5.13.6	CSid assignment .....	56
4.5.13.7	QLminimum provisioning.....	56
4.5.13.8	NE clock behaviour .....	56
4.5.13.9	NS Priority configuration .....	57
4.5.13.10	NS Lockout commands.....	57
4.5.13.11	NS External commands .....	57
4.5.13.12	NS Wait to restore time .....	57
4.5.13.13	Select Sa bit for SSM provisioning.....	58
4.5.14	Performance Monitoring 15 minute and 24 hour TR and RTR threshold setting.....	58
5	DCC Layer Functions .....	59
5.1	DCC connection function DCC_C.....	60
6	V11 Section Layer Functions .....	61
6.1	V11 Connection function V11_C .....	62
6.2	V11 Trail Termination functions .....	62
6.2.1	V11 Trail Termination Source V11_TT_So .....	62
6.2.2	V11 Trail Termination Sink V11_TT_Sk .....	63
6.3	V11 Adaptation functions .....	63
6.3.1	V11 to V0X Adaptation Source V11/V0X_A_So.....	63
6.3.2	V11 to V0X Adaptation Sink V11/V0X_A_Sk .....	64

7	Power Feed Functions .....	65
	<b>Annex A (informative): Applications/Topologies of Performance Monitoring .....</b>	<b>66</b>
A.1	Single-ended, bi-directional performance monitoring architecture at a termination node.....	66
A.2	Single-ended, bi-directional performance monitoring architecture at an intermediate node .....	67
A.3	Dual ended, bi-directional performance monitoring architecture at termination nodes.....	68
A.4	Performance monitoring architecture at an intermediate node for fault localization.....	68
A.5	Single ended, bi-directional TCM related performance monitoring architecture at a TC termination node .....	69
A.6	Single ended, bi-directional TCM related performance monitoring architecture at an intermediate node.....	69
	<b>Annex B (informative): Examples of some performance monitoring packages .....</b>	<b>71</b>
	<b>Annex C (informative): Use of NPME/FPME functions when both G.826 and M.2100/M.2101.1 packages are selected for one termination point .....</b>	<b>73</b>
	Bibliography .....	76
	History.....	77

---

## Intellectual Property Rights

IPRs essential or potentially essential to the present document may have been declared to ETSI. The information pertaining to these essential IPRs, if any, is publicly available for **ETSI members and non-members**, and can be found in SR 000 314: "*Intellectual Property Rights (IPRs); Essential, or potentially Essential, IPRs notified to ETSI in respect of ETSI standards*", which is available **free of charge** from the ETSI Secretariat. Latest updates are available on the ETSI Web server (<http://www.etsi.org/ipr>).

Pursuant to the ETSI IPR Policy, no investigation, including IPR searches, has been carried out by ETSI. No guarantee can be given as to the existence of other IPRs not referenced in SR 000 314 (or the updates on the ETSI Web server) which are, or may be, or may become, essential to the present document.

---

## Foreword

This European Standard (Telecommunications series) has been produced by ETSI Technical Committee Transmission and Multiplexing (TM), and is now submitted for the Public Enquiry phase of the ETSI standards Two-step Approval Procedure.

The present document is one of a family of documents that has been produced in order to provide inter-vendor and inter-operator compatibility of Synchronous Digital Hierarchy (SDH) equipment.

The present document is part 7-1 of a multi-part EN covering the generic requirements of transport functionality of equipment, as identified below:

Part 1-1: "Generic processes and performance";

Part 1-2: "General information about Implementation Conformance Statement (ICS) proforma";

Part 2-1: "Synchronous Digital Hierarchy (SDH) and Plesiochronous Digital Hierarchy (PDH) physical section layer functions";

Part 2-2: "Synchronous Digital Hierarchy (SDH) and Plesiochronous Digital Hierarchy (PDH) physical section layer functions; Implementation Conformance Statement (ICS) proforma specification";

Part 3-1: "Synchronous Transport Module-N (STM-N) regenerator and multiplex section layer functions";

Part 3-2: "Synchronous Transport Module-N (STM-N) regenerator and multiplex section layer functions; Implementation Conformance Statement (ICS) proforma specification";

Part 4-1: "Synchronous Digital Hierarchy (SDH) path layer functions";

Part 4-2: "Synchronous Digital Hierarchy (SDH) path layer functions; Implementation Conformance Statement (ICS) proforma specification";

Part 5-1: "Plesiochronous Digital Hierarchy (PDH) path layer functions";

Part 5-2: "Plesiochronous Digital Hierarchy (PDH) path layer functions; Implementation Conformance Statement (ICS) proforma specification";

Part 6-1: "Synchronization layer functions";

Part 6-2: "Synchronization layer functions; Implementation Conformance Statement (ICS) proforma specification";

**Part 7-1: "Equipment management and auxiliary layer functions";**

Part 7-2: "Auxiliary layer functions; Implementation Conformance Statement (ICS) proforma specification";

Parts 2 to 7 specify the layers and their atomic functions.

NOTE: The SDH radio equipment functional blocks are addressed by ETSI WG TM4.

Various of the above parts have previously been published as parts of ETS 300 417.

They have been converted into parts of EN 300 417 without technical changes, but some editorial changes have been necessary (e.g. references). In particular:

- Parts 2-1, 2-2 and 3-2 have been modified to take account of editorial errors present in edition 1;
- Part 1-1 has had its title change to align with other parts published at a later date.

Also note that in the meantime parts 8-1 and 8-2 together with all parts x-3 (Abstract Test Suites) have been stopped.

<b>Proposed national transposition dates</b>	
Date of latest announcement of this EN (doa):	3 months after ETSI publication
Date of latest publication of new National Standard or endorsement of this EN (dop/e):	6 months after doa
Date of withdrawal of any conflicting National Standard (dow):	6 months after doa

## Introduction

The present document specifies for fault management, performance monitoring, and configuration management a library of basic equipment management function (EMF) building blocks and a set of rules by which they are combined in order to describe an equipment's EMF functionality. The library defined in the present document forms part of the set of libraries defined furthermore in the other parts of EN 300 417. In addition, a number of compound functions consisting of a number of EMF building blocks are defined.

**NOTE:** Not every function defined in the present document is required for every application. Different subsets of functions may be assembled in different ways to provide a variety of different capabilities. Network operators and equipment suppliers may choose which functions to implement for each application.

In addition, the present document specifies functions in the auxiliary layers: DCC layer and V11 section layer.

---

# 1 Scope

The present document specifies a library of basic building blocks and a set of rules by which they are combined in order to describe transport and equipment management function (EMF) functionality in equipment. The library comprises the functional building blocks needed to completely specify the generic functional structure of the European Digital Transmission Hierarchy. Equipment, which is compliant with the present document, will be describable as an interconnection of a subset of these functional blocks contained within the present document. The interconnections of these blocks will obey the combination rules given. The generic functionality is described in EN 300 417-1-1 [2].

---

# 2 References

The following documents contain provisions which, through reference in this text, constitute provisions of the present document.

- References are either specific (identified by date of publication, edition number, version number, etc.) or non-specific.
- For a specific reference, subsequent revisions do not apply.
- For a non-specific reference, the latest version applies.
- A non-specific reference to an ETS shall also be taken to refer to later versions published as an EN with the same number.

- [1] ETS 300 147 (Edition 3): "Transmission and Multiplexing (TM); Synchronous Digital Hierarchy (SDH); Multiplexing structure".
- [2] EN 300 417-1-1: "Transmission and Multiplexing (TM); Generic requirements of transport functionality of equipment; Part 1-1: Generic processes and performance".
- [3] EN 300 417-4-1: "Transmission and Multiplexing (TM); Generic requirements of transport functionality of equipment; Part 4-1: Synchronous Digital Hierarchy (SDH) path layer functions".
- [4] EN 300 417-6-1: "Transmission and Multiplexing (TM); Generic functional requirements of transport functionality of equipment; Part 6-1: Synchronization layer functions".
- [5] EN 301 167: "Transmission and Multiplexing (TM); Management of Synchronous Digital Hierarchy (SDH) transmission equipment; Fault management and performance monitoring; Functional description".
- [6] ETS 300 167: "Transmission and Multiplexing (TM); Functional characteristics of 2 048 kbit/s interfaces".
- [7] ITU-T Recommendation M.2100 (1995): "Performance limits for bringing-into-service and maintenance of international PDH paths, sections and transmission systems".
- [8] ITU-T Recommendation M.2101.1 (1997): "Performance limits for bringing-into-service and maintenance of international SDH paths and multiplex sections".
- [9] ITU-T Recommendation M.2120 (1997): "PDH path, section and transmission system and SDH path and multiplex section fault detection and localization procedures".
- [10] ITU-T Recommendation Q. 921 (1997): "ISDN user-network interface – Data link layer specification".
- [11] ITU-T Recommendation V.11 (1996): "Electrical characteristics for balanced double-current interchange circuits operating at data signalling rates up to 10 Mbit/s".
- [12] ETS 300 304: "Transmission and Multiplexing (TM); Synchronous Digital Hierarchy (SDH); SDH information model for the Network Element (NE) view".



- [13] ETS 300 371: "Transmission and Multiplexing (TM); Plesiochronous Digital Hierarchy (PDH) information model for the Network Element (NE) view".
- [14] ETS 300 411: "Transmission and Multiplexing (TM); Performance monitoring; Information model for the Network Element (NE) view".
- [15] ETS 300 412: "Transmission and Multiplexing (TM); Payload Configuration; Information model for the Network Element (NE) view".
- [16] ETS 300 413: "Transmission and Multiplexing (TM); Multiplex section protection; Information model for the Network Element (NE) view".
- [17] ETS 300 493: "Transmission and Multiplexing (TM); Synchronous Digital Hierarchy (SDH) information model of the Sub Network Connection Protection (SNCP) for the Network Element (NE) view".
- [18] EN 301 155: "Synchronous Digital Hierarchy (SDH); Uni-directional performance monitoring for the network element view".
- [19] EN 301 268: "Telecommunications Management Network (TMN); Linear multiplex section protection configuration information model for the Network Element (NE) view".
- [20] EN 301 384: "Telecommunications Management Network (TMN); Performance monitoring for Plesynchronous Digital Hierarchy (PDH) interfaces; Information model for the Network Element (NE) view".
- [21] ETS 300 337: "Transmission and Multiplexing (TM); Generic frame structures for the transport of various signals (including Asynchronous Transfer Mode (ATM) cells and Synchronous Digital Hierarchy (SDH) elements) at the ITU-T Recommendation G.702 hierarchical rates of 2 048 kbit/s, 34 368 kbit/s and 139 264 kbit/s".
- [22] ES 202 098: "Telecommunications Management Network (TMN); Information model for a VC transport system using a 34 Mbit/s PDH transmission system in accordance with ITU-T Recommendation G.832".
- [23] ITU-T Recommendation Q.822 (1994): "Stage 1, stage 2 and stage 3 description for the Q3 interface – Performance management".
- [24] ITU-T Recommendation M.20 (1992): "Maintenance philosophy for telecommunications networks".
- [25] ITU-T Recommendation G.774 (1992): "Synchronous digital hierarchy (SDH) management information model for the network element view".

---

## 3 Definitions, abbreviations and symbols

### 3.1 Definitions

For the purposes of the present document, the terms and definitions given in EN 300 417-1-1 [2] apply.

### 3.2 Abbreviations

For the purposes of the present document, the following abbreviations apply:

15m	15 minutes
24h	24 hours
AccPer	Accumulation Period
AcSL	Accepted Signal Label
AcTI	Accepted Trace Identifier
AF	Atomic Function

AvFb	Availability Function bi-directional
AvFu	Availability Function uni-directional
AI	Adapted Information
AIS	Alarm Indication Signal
AP	Access Point
API	Access Point Identifier
APS	Automatic Protection Switch
ARCH	ARCHitecture
ATM	Asynchronous Transfer Mode
AU	Administrative Unit
AUG	Administrative Unit Group
AU-n	Administrative Unit, level n
A/Z	from A to Z
BBE	Background Block Error
BUT	Begin of Unavailable Time
CI	Characteristic Information
CK	ClocK
CLR	CLeaR
ClrLON	Clear Lockout of Normal traffic signal from protection
CM	Configuration Management
CM	Connection Matrix
CP	Connection Point
CRC	Cyclic Redundancy Check
CS	Clock Source
CSES	Consecutive Severely Errored Seconds
CUR15m	Current 15 minutes
CUR24h	Current 24 hour
DCC	Data Communications Channel
DEC	DECrement
DEG	DEGraded
DEGM	DEGraded Monitor period
DEGTHR	DEGraded THreshold
DMA	Deferred Maintenance Alarm
DS	Defect Second
DSTATUS	Data STATUS
DTYPE	Data TYPE
EBC	Errored Block Count
EDC	Error Detection Code
EFS	Equipment Functional Specification
EMF	Equipment Management Function
EQ	EQuipment
ES	Electrical Section
ES	Errored Second
EUT	End of Unavailable Time
EXER	Exercise
EXER-R	Exercise - Ring
EXER-S	Exercise - Span
EXTCMD	EXTernal CoMmanD
ExTI	Expected Trace Identifier
F_B	Far-end Block
FAS	Frame Alignment Signal
FBBE	Far-end Background Block Error
FES	Far-end Errored Second
FM	Fault Management
FPME	Far-end Performance Monitoring Event
FOP	Failure Of Protocol
FORCEDN	FORCE Down
FS	Frame Start signal
FSES	Far-end Severely Errored Second
FS-R	Forced Switch to protection - ring

FS-S	Forced Switch to protection - span
FSw	Forced Switch
G826EN	G.826 bi-directional package at the trail end node
G826IN	G.826 bi-directional package at intermediate node
HO	Hold Off (used in HOTime)
HOB	Head Of Bus
HOVC	Higher Order Virtual Container
HP	Higher order Path
ID	IDentifier
IF	In Frame state
IM	In Multiframe state
INC	INCRement
IncAIS	Incoming AIS
LC	Link Connection
LO	Lockout Of protection
LOA	Loss Of Alignment; generic for LOF, LOM, LOP
LOF	Loss Of Frame
LOM	Loss Of Multiframe
LON	Lockout Of Normal traffic signal from protection
LOP	Loss Of Pointer
LOS	Loss Of Signal
LOVC	Lower Order Virtual Container
LOW-R	Lockout Of Working channels - ring switch
LOW-S	Lockout Of Working channels - span switch
LP-A	Lockout of Protection – All spans
LP-S	Lockout of Protection - Span
LSS	Loss of Sequence Structure
LSTATUS	Link STATUS
LTC	Loss of Tandem Connection
M21FE	M.2100/M.2101.1 far-end (Z/A direction) maintenance (uni-directional) package
M21NE	M.2100/M.2101.1 near-end (A/Z direction) maintenance (uni-directional) package
MC	Matrix Connection
MCF	Message Communications Function
MEI	Maintenance Event Information
MI	Management Information
MP	Management Point
MO	Managed Object
MON	MONitored
MP	Management Point
MS	Multiplex Section
MS1	STM-1 Multiplex Section
MS16	STM-16 Multiplex Section
MS4	STM-4 Multiplex Section
MS64	STM-64 Multiplex Section
MSB	Most Significant Bit
MSOH	Multiplex Section OverHead
MSP	Multiplex Section Protection
MS-R	Manual Switch to protection - ring
MS-S	Manual Switch to protection - span
MSw	Manual Switch
N/A	Not Applicable
N_B	Near-end Block
NBBE	Near-end Background Block Error
NC	Network Connection
NCI	No CRC-4 multiframe Indication
NE	Network Element
NES	Near-end Errored Second
NMON	Not MONitored
NPME	Near-end Performance Monitoring Event
NSES	Near-end Severely Errored Second

OAM	Operation, Administration and Management
ODI	Outgoing Defect Indication
OEI	Outgoing Error Indication
OF	Outgoing Far-end
OF_B	Outgoing Far-end VC Block
OFS	Out of Frame Second
OH	OverHead
ON	Outgoing Near-end
OOF	Out Of Frame state
OOM	Out Of Multiframe state
OPER	OPERation
OS	Optical Section
OSF	Outgoing Signal Fail
OW	Order Wire
P	Protection
P0s	synchronous 64 kbit/s layer
P11x	1 544 kbit/s layer (transparent)
P12s	2 048 kbit/s PDH path layer with synchronous 125 $\mu$ s frame structure according to ETS 300 167 [6]
P12x	2 048 kbit/s layer (transparent)
P22e	8 448 kbit/s PDH path layer with 4 plesiochronous 2 048 kbit/s
P22x	8 448 kbit/s layer (transparent)
P31e	34 368 kbit/s PDH path layer with 4 plesiochronous 8 448 kbit/s
P31s	34 368 kbit/s PDH path layer with synchronous 125 $\mu$ s frame structure according to ETS 300 337 [21]
P31x	34 368 kbit/s layer (transparent)
P32x	44 736 kbit/s layer (transparent)
P4e	139 264 kbit/s PDH path layer with 4 plesiochronous 34 368 kbit/s
P4s	139 264 kbit/s PDH path layer with synchronous 125 $\mu$ s frame structure according to ETS 300 337 [21]
P4x	139 264 kbit/s layer (transparent)
PDH	Plesiochronous Digital Hierarchy
PJE	Pointer Justification Event
PJE-	Negative Pointer Justification Event
PJE+	Positive Pointer Justification Event
PLM	PayLoad Mismatch
PM	Performance Monitoring
PMA	Prompt Maintenance Alarm
PMCF	Performance Monitoring Clock Function
PMF	Performance Monitoring Function
POH	Path OverHead
ppm	part per million
PRBS	Pseudo Random Binary Sequence
PRC	Primary Reference Clock
PROT	PROTection
PS	Protection Switching
PTR	PoinTeR
QoS	Quality of Service
RDI	Remote Defect Indicator
REI	Remote Error Indicator
RI	Remote Information
RP	Remote Point
RS	Regenerator Section
RS1	STM-1 Regenerator Section
RS16	STM-16 Regenerator Section
RS4	STM-4 Regenerator Section
RS64	STM-64 Regenerator Section
RSOH	Regenerator Section OverHead
RTC	Real Time Clock
RTHR	Reset Threshold

RTR	Reset Threshold Report
RxSL	Received Signal Label
RxTI	Received Trace identifier
SDH	Synchronous Digital Hierarchy
SES	Severely Errored Second
SF	Signal Fail
Sk	Sink
SNC	Sub-Network Connection
SNC/I	Inherently monitored Sub-Network Connection protection
SNC/N	Non-intrusively monitored Sub-Network Connection protection
SNC/S	Sublayer monitored Sub-Network Connection protection
So	Source
SOH	Section OverHead
SPRING	Shared Protection RING
SSD	Server Signal Degrade
SSF	Server Signal Fail
SSM	Synchronization Status Message
STM	Synchronous Transport Module
STM-N	Synchronous Transport Module, level N
TC	Tandem Connection
TCn	Tandem Connection level n
TCP	Termination Connection Point
THR	Threshold
ThrFd	Dual level Thresholding Function
ThrFs	Single level Thresholding Function
TI	Timing Information
TI	Trace Identifier
TIM	Trace Identifier Mismatch
TIMdis	Trace Identifier Mismatch disable
TMN	Telecommunications Management Network
TP	Timing Point
TPmode	Termination Point mode
TR	Threshold Report
TS	Time Slot
TSD	Trail Signal Degrade
TSE	Test Sequence Error
TSF	Trail Signal Fail
TSN	Tributary Signal Number
TT	Trail Termination function
TTI	Trail Trace Identifier
TU	Tributary Unit
TUG	Tributary Unit Group
TxTI	Transmitted Trace Identifier
UAS	Unavailable Second
UAT	Unavailable Time
UNEQ	UNEQuipped
UTC	Universal Time Coordinated
VC	Virtual Container
VC-n	Virtual Container, level n
W	Working
WTR	Wait To Restore
Z/A	from Z to A

### 3.3 Symbols and Diagrammatic Conventions

For the purposes of the present document, the symbols and diagrammatic conventions described in EN 300 417-1-1 [2] apply.

## 4 Equipment management function

The equipment management function (EMF) (figure 1) provides the means through which a network element level manager manages the network element function (NEF).

The EMF interacts with the transport and synchronization layer atomic functions by exchanging information (MI: management information) across the MP reference points. The EMF contains a number of functions that provide a data reduction mechanism on the information received across the MP reference points. These function outputs are available to the agent via the network element resources and management application functions (MAF) which represent this information as managed objects.

Network element resources provide event processing and storage. The MAF process the information provided to and by the NE resources. For example, the agent converts this information to CMISE (common management information service element) messages and responds to CMISE messages from the manager by performing the appropriate operations on the managed objects.

**NOTE:** The management application function specification is outside the scope of the present document.

Network elements may support several functions, which can be operated only in exclusivity of each other. Besides such configuration provisionings, provisionings are needed for parameters in individual functions and processes within a NE.

A number of functions/processes and reports have a notion of time. The network element Real Time Clock function provides this time information.

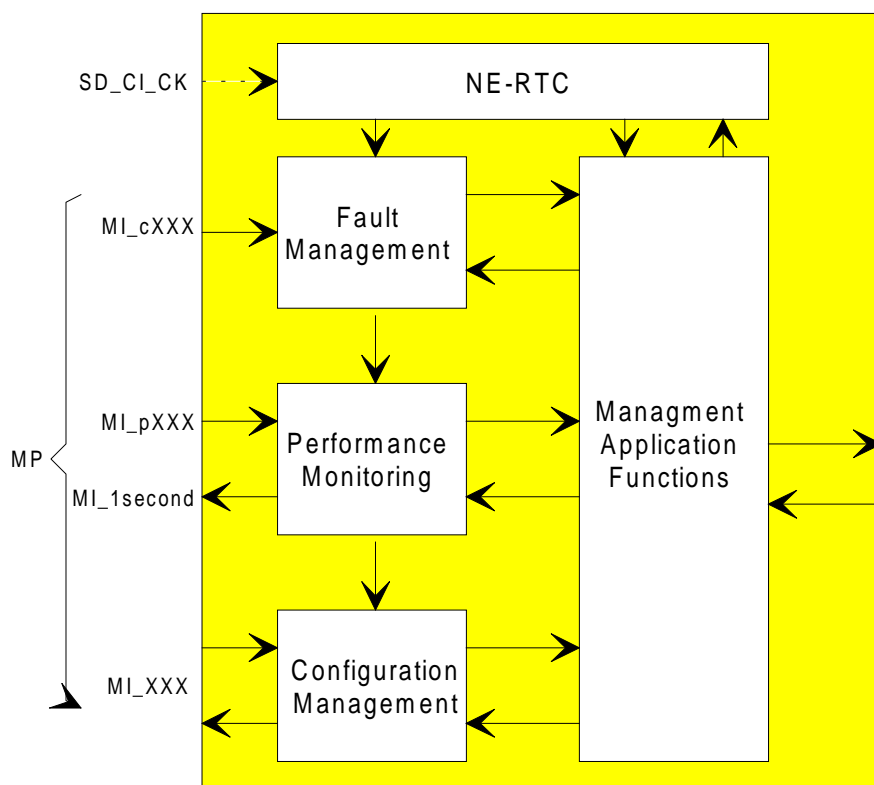

**Figure 1: Equipment Management Function process block diagram**

**MP**

The MI at this point is a set of management signals to/from the atomic functions, including configuration and operation control, fault management, performance monitoring, protection switching, synchronization control and reporting signals.

**SD\_CP**

The CI at this point is the SD\_CI\_CK signal.

## 4.1 Network Element - Real Time Clock (NE-RTC) Function

Symbol:

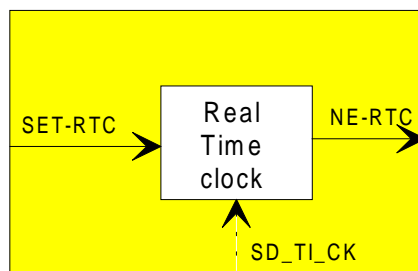

Figure 2: NE RTC function

**Interfaces:**

Table 1: NE-RTC input and output signals

Input(s)	Output(s)
SET-RTC SD_TI_CK	NE-RTC

**Processes:**

The real time clock is a logical entity within the NE which provides date and time information to equipment management functions within the NE.

The real time clock shall have a resolution of 1 second.

The date shall be represented as year:month:day and be "year 2000" compliant. The time shall be represented as hour:minute:second.

On receipt of the SET-RTC command, the real time clock shall be set to the date:time specified by the SET-RTC command.

On a regular basis, the RTC is to be realigned with UTC. This realignment period should be determined such that the correction is less than  $\pm 10$  seconds to prevent that all active PMFs declare suspect intervals.

The real time clock may be a free running clock or may be locked to any available clock source (e.g. equipment clock SD\_TI\_CK).

The stability of the real time clock shall be such that in any 24 hour period (where a SET-RTC command has not been received), the RTC shall not have deviated by more than  $\pm Y$  seconds from the 24 hour period of a UTC; Y is for further study.

When a SET-RTC command is received, the error between the Management command at the input to the NE (figure 3) and the resultant NE-RTC time shall be within  $\pm X$  seconds; X is for further study.

**NOTE:** The relationship and timing transfer between the management command at the input to the NE and the resultant SET-RTC command is beyond the scope of the present document.

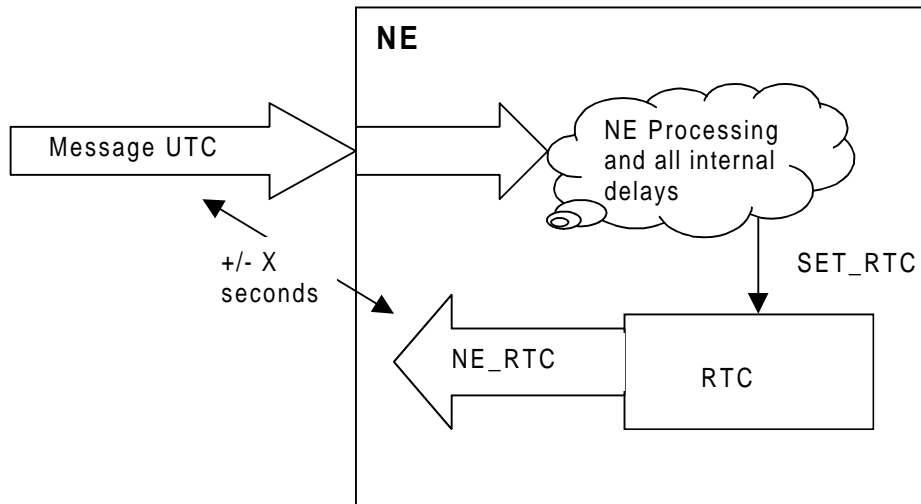

Figure 3: NE\_RTC and UTC relation

## 4.2 Fault Management Functions

The equipment management function within the network element performs a persistency check on the fault causes before it declares a fault cause a failure. The fault causes are generated by the atomic function fault management process. A severity is associated with each alarm.

The failure is reported via the agent process (output failure report) and by means of alarms (audible and visible indicators). Typically, alarms can be divided into unit level alarms, NE level alarms and station alarms.

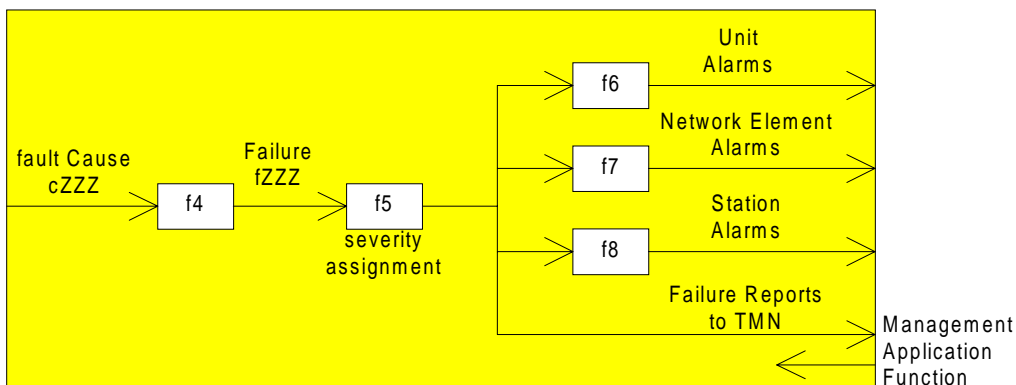

Figure 4: Fault management inside EMF function

Filter	Function
f4	integration of fault causes into failures
f5	assign severity to failure
f6	translation of failures into Unit alarms
f7	translation of failures into Network Element alarms (e.g. severity)
f8	translation of failures into station alarms & alarm disconnect control

### 4.2.1 Failure filter f4

A transmission failure shall be declared if the fault cause persists continuously for  $2,5 \pm 0,5$  seconds. The failure shall be cleared if the fault cause is absent continuously for  $10 \pm 0,5$  seconds.

The failure change (declaration/clearing) shall be time stamped. The time stamp shall indicate the start of the fault cause to failure integration time. The time stamp shall have an accuracy of 1 second relative to the NE-RTC.

A generic list of failures is shown in table 2.



**Table 2: Failures declared per atomic function**

Termination sink	Adaptation sink	Connection
fSSF	fLOF	fFOP
fUNEQ	fLOM	
fTIM	fLOP	
fDEG	fAIS	
fLOS	fPLM	
fRDI	fLTI	
fLTC	fLSS	
fIncAIS		
fODI		

## 4.2.2 Severity assignment filter f5

A severity is used to indicate the management perception of the severity of a fault which could depend on the service dependency of the fault. Refer to EN 301 167 [5].

NOTE: Two severity schemes are being used. One based on the ITU-T Recommendations X series which has the severity elements: critical, major, minor and warning. The other based on the ITU-T Recommendation M.20 [24] which has the severity elements: prompt maintenance alarm (PMA), deferred maintenance alarm (DMA) and maintenance event information (MEI).

## 4.2.3 Replaceable unit alarm filter f6

There are so many preferences amongst the public network operators, standardization of the unit alarms is not possible at the moment.

NOTE: The role of this interface within management procedures should be reviewed in light of increased functionality of the Q interface.

## 4.2.4 Network element alarm filter f7

There are so many preferences amongst the public network operators, standardization of the network element alarms is not possible at the moment.

NOTE: The role of this interface within management procedures should be reviewed in light of increased functionality of the Q interface.

## 4.2.5 Station alarm filter f8

There are so many preferences amongst the public network operators, standardization of the network element alarms is not possible at the moment.

NOTE: The role of this interface within management procedures should be reviewed in light of increased functionality of the Q interface.

## 4.3 Management Application Functions

Refer to information model standards (ETS 300 304 [12], ETS 300 371 [13], ETS 300 411 [14], ETS 300 412 [15], ETS 300 413 [16], ETS 300 493 [17], EN 301 155 [18], EN 301 268 [19], EN 301 384 [20], ES 202 098 [22]).

## 4.4 Performance Monitoring Functions

The EMF performance monitoring process collects the event counts associated with:

- the trail performance parameters Errored Seconds (ES), Severely Errored Seconds (SES), Background Block Error (BBE) and Unavailable Time (UAT)/Unavailable Second (UAS);
- the link connection performance parameter Pointer Justification Event (PJE).

It processes the event counts to derive the performance parameters, and stores these performance events in registers. Such information can be used to sectionalize faults and to locate sources of intermittent errors, and/or determine the quality of the service.

Figure 5 presents an overview of the Performance Monitoring Functions (PMF) within the EMF. The shaded boxes are PMFs defined in the present document. The intermediate ellipses represent the interconnect options between the PMFs. The Equipment Functional Specification (EFS) defines which (sub)set of PMFs is (to be) supported by the equipment, as well as the quantity of each PMF.

NOTE 1: For the case where the number of transport atomic functions exceed the number of performance monitoring resources, selection may be indicated by "performance monitoring connection functions", or by alternative means. This is outside the scope of the present document. For the case where a such selectivity is not present or is not required, the interconnect is predefined and can be represented in the EFS by explicit interconnections between PMFs and atomic functions.

The NPME function determines on a per second basis the number of near-end background block errors (BBE), and whether an ES and/or SES occurred. The FPME function determines on a per second basis the number of far-end Background Block Errors (BBE), and whether an ES and/or SES occurred.

The AvFu function determines whether a one second is uni-directionally available or unavailable, and passes through the (ES, SES, BBE) input signal's value for seconds in available time. The input signal value in seconds in unavailable time is not output, instead the value "0" is output. The AvFb function determines whether a one second is bi-directionally available or unavailable, and passes through the (ES, SES, BBE) input signal's value in seconds in available time. The input signal value in seconds in unavailable time is not output, instead the value "0" is output.

The delay function delays the input signal (which is not subject to "availability" processing) by 10 seconds to align it with the performance monitoring time base which is 10 seconds delayed from the time of day.

The 15m function accumulates the input values (from i.e. ES, SES, BBE, PJE+, PJE-, TSE) over periods of 15 minutes. The function contains seventeen 15 minute registers: one current and 16 recent registers. The 24h function accumulates the input signal values over periods of 24 hours. The function contains two 24 hour registers: one current and one recent register.

The ThrFs and ThrFd functions can be used to generate an autonomous event report (a threshold report) when the count in the current 15m/24h register to which it is connected reaches or exceeds the provisioned threshold value. The ThrFd function generates in addition a reset threshold report when the count at the end of a 15m period undercrosses a provisioned reset threshold.

The inputs to the performance monitoring process - the Performance Monitoring primitives (MI\_pXXX) - are one second counts of:

- errored blocks (pX\_EBC), defect second (pX\_DS) generated by termination sink functions;
- pointer justification events (pPJE+, pPJE-) generated by adaptation sink functions.

NOTE 2: "X" represents near-end (X = N), far-end (X = F), outgoing near-end (X = ON), or outgoing far-end (x = of).

NOTE 3: Tandem connections support so called "Outgoing Defect Indication" and "Outgoing Error Indication". For details see ETS 300 147 [1] and EN 300 417-4-1 [3].

These primitives are passed from the Atomic Functions (AFs) to the Equipment Management Function (EMF) for further processing.

The Performance monitoring timing function outputs the 1 second indication (MI\_1second) towards the atomic functions to perform the 1 second counting of the performance primitives pXXX.

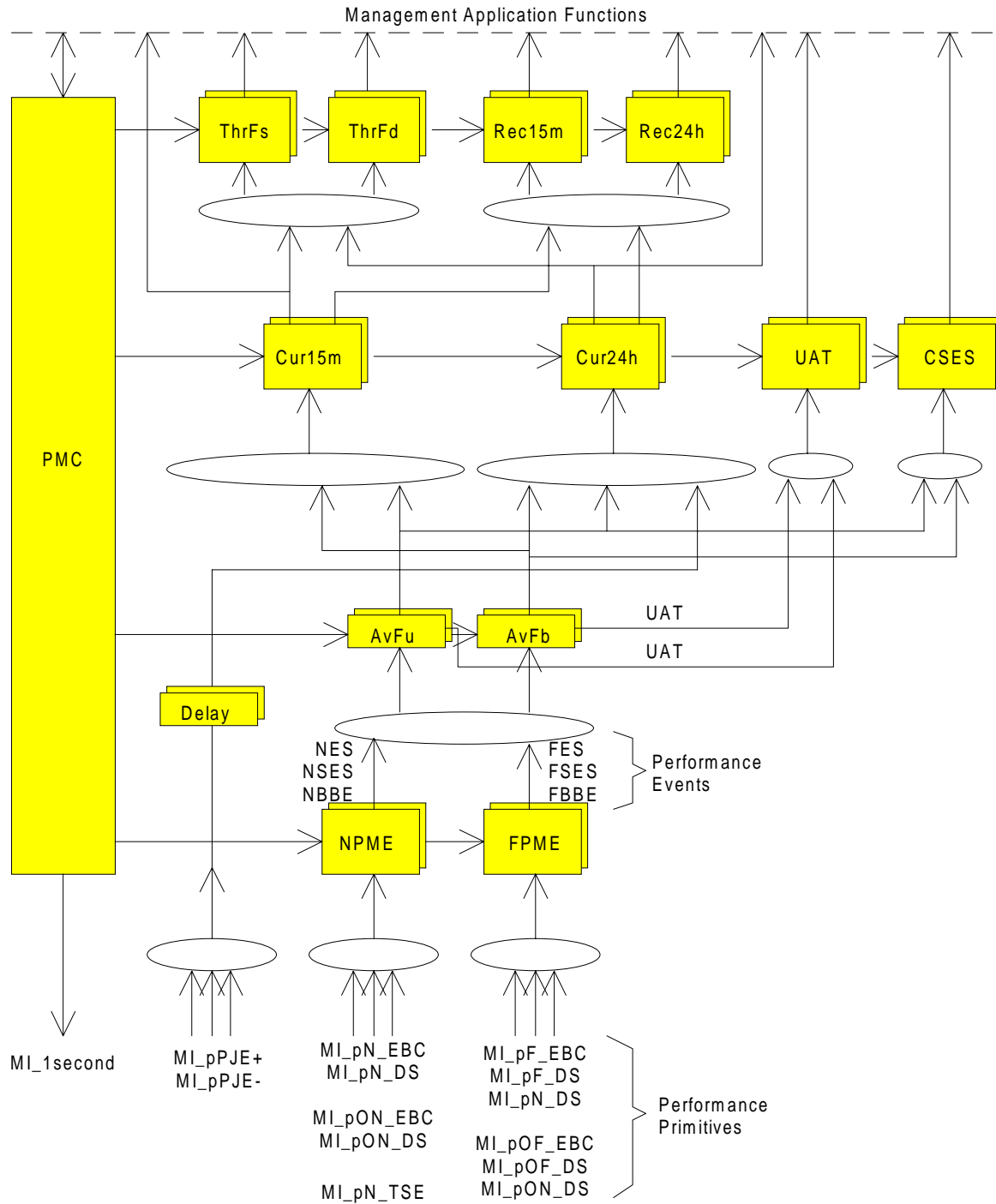

**Figure 5: Overview of Performance Monitoring functions and their input/output relations**

Performance monitoring functions connect to the higher layer management functions. Those functions are defined in ETS 300 304 [12], ETS 300 411 [14], EN 301 155 [18], DEN/TM-2210-3 [5] and other related standards. The present document addresses performance monitoring from an equipment point of view. EN 301 167 [5] describes the performance monitoring from a network point of view.

#### 4.4.1 Performance monitoring clock function PMC

Symbol:

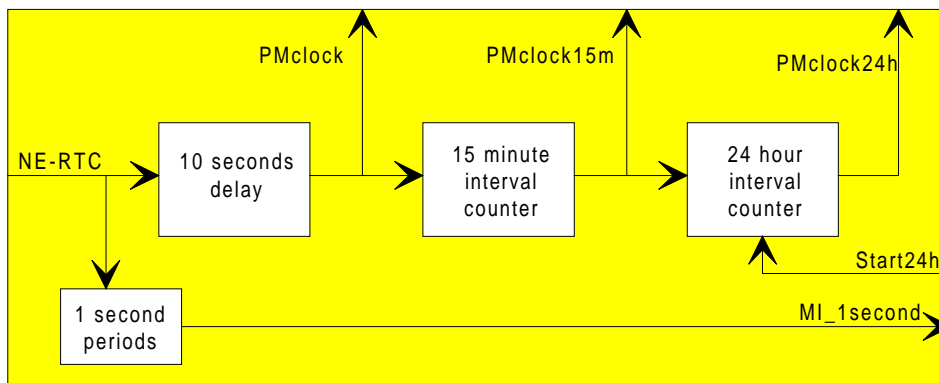

Figure 6: PM clock function

Interfaces:

Table 3: PM clock function input and output signals

Input(s)	Output(s)
NE-RTC Start24h	PMclock PMclock15m PMclock24h MI_1second

Processes:

The function generates the clock signals associated with the performance monitoring processing in the atomic functions and the performance monitoring functions within a network element.

**1 second periods:** this function shall generate the 1second signal at the end of each 1 second period as indicated by the NE real time clock (NE-RTC).

**10 seconds delay:** for performance monitoring purposes, the NE-RTC shall be delayed by 10 seconds (PMclock) for the purpose to accommodate the effects (a 10 second delay) associated with the unavailable time calculation.

**15 minute interval counter:** this process generates the 15 minute period indications (PMclock15m) which are aligned with the end of each quarter of an hour period (00:00, 15:00, 30:00, 45:00) with respect to PMclock. The start of a period is equal to the end of the previous period. If the NE-RTC is not preset, each 15 minute period spans 900 one second periods.

**24 hour interval counter:** this process generates the 24 hour period indications (PMclock24h) which are aligned with the end of a quarter of an hour period (00:00:00, 00:15:00, 00:30:00, ... 23:45:00) with respect to PMclock. The start of a period is equal to the end of the previous period. If the NE-RTC is not preset, each 24 hour period spans 86400 one second periods.

For 24-hour data specifically, the NE may be instructed (Start24h) on when to begin measurement of the 24 hour period for the purpose of reporting data. The NE shall be able to begin the measurement at the start of any 15 minute period (refer to subclause 2.3.3.3 of ITU-T Recommendation M.2120 [9]) (default shall be 00:00 on the PMclock).

## 4.4.2 Performance monitoring events functions

### 4.4.2.1 Near-end performance monitoring event function (NPME)

Symbol:

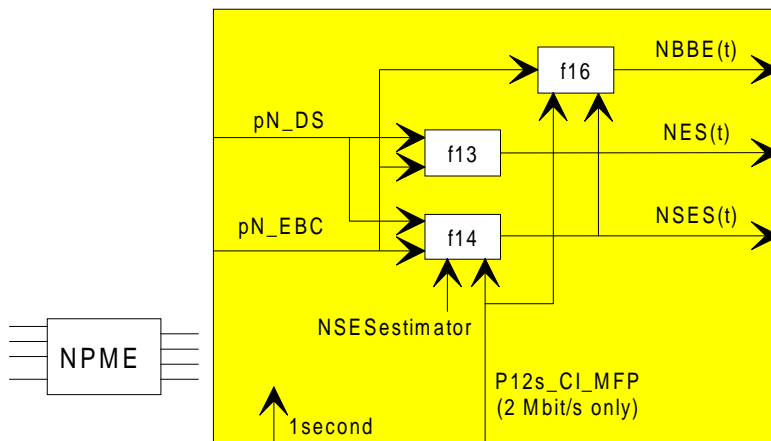

Figure 7: Near-end performance monitoring event function symbol and process diagram

Interfaces:

Table 4: NPME input and output signals

Input(s)	Output(s)
MI_pN_DS	NBBE
MI_pN_EBC	NES
MI_1second	NSES
P12s_CI_MFP (for P12s signals only)	

Processes:

This function determines on a per second basis the number of near-end Background Block Errors (BBE), and whether an ES and/or SES occurred.

The EBC and DS performance monitoring primitive signals received from a transport atomic function are the inputs for the determination of the performance events BBE, ES, SES.

For the case a DS input is not connected, DS shall be assumed to be false. For the case a EBC input is not connected, EBC shall be assumed to be "0".

Figure 7 presents the processes and their interconnect within the Near-end Performance Monitoring Event (NPME) atomic performance monitoring function.

**f13 (see note):** a Near-end Errored Second (NES) performance monitoring event signal shall be generated if pN\_DS is set or if  $pN\_EBC \geq 1$ ; i.e.:

- $NES \leftarrow (pN\_DS = \text{true}) \text{ or } (pN\_EBC \geq 1)$

NOTE 1: "filter" numbers (e.g. "f13") are taken from EN 300 417-1-1 [2].

**f14:** a Near-end Severely Errored Second (NSES) performance monitoring event signal shall be generated if pN\_DS is set or if  $pN\_EBC \geq \text{NSEstimator}$  (Near-end SEStimator); i.e.:

- $NSES \leftarrow (pN\_DS = \text{true}) \text{ or } (pN\_EBC \geq \text{NSEstimator})$ .

NOTE 2: The NSEstimator value depends on the network layer this NPME function is connected to.

For the case of 2 Mbit/s (P12s) signals, the following NSES definition shall apply:

- $NSES \leftarrow (pN\_DS = \text{true}) \text{ or } [(pN\_EBC \geq NSESestimator) \text{ and } CI\_MFP = \text{true}] \text{ or } [(pN\_EBC \geq 28) \text{ and } (CI\_MFP = \text{false})]$ .

**SES Estimator:** the Near-end SES estimator value is network layer specific and shall be as specified in table 5.

**Table 5: SES Estimators**

Layer	SES estimator
RS1	Refer to
RS4	subclause 5.4.2 of EN 301 167 [5]
RS16	subclause 5.4.3.3 of EN 301 167 [5]
RS64	
MS1	Refer to
MS4	subclause 5.3.2 of EN 301 167 [5]
MS16	subclause 5.3.3.3 of EN 301 167 [5]
MS64	
VC-4-64c	for further study
VC-4-16c	
VC-4-4c	Refer to
VC-4	subclause 5.2.2 of EN 301 167 [5]
VC-3	subclause 5.2.3.3 of EN 301 167 [5]
VC-2	
VC-12	
VC-11	
P4s	Refer to
P31s	Annex B/G.826
P4e	Refer to
P31e	Annex B/M.2100
P22e	Annex B/G.826
P12s (FAS) (3)	
P12s (CRC) (1)(2)	
NOTE 1: Two different values are being specified; for uni-directional performance monitoring defined in ITU-T Recommendation M.2100 [7] the SES estimator is 805, while for bi-directional performance monitoring defined in G.826 the SES estimator is 300. Refer to annex C.	
NOTE 2: For a 2 Mbit/s path, P12s (CRC) values are applicable when the CRC-4 interworking mode is either ON or AUTO with the latter case requiring CRC-4 multiframe alignment being detected. For the case of CRC-4 interworking modes OFF and AUTO/loss of multiframe, PM has to be based on FAS errors. Refer to annex C.	
NOTE 3: SESestimator for the case FAS errors are used is 28; refer to ITU-T Recommendation M.2100 [7].	

**f16:** the Near-end Background Block Error (NBBE) performance monitoring event signal shall equal pN\_EBC if the NSES of that second is not set. Otherwise, NBBE shall be zero.

For the case of 2 Mbit/s (P12s) signals, the following NBBE definition shall apply:

the Near-end Background Block Error (NBBE) performance monitoring event signal shall equal pN\_EBC if the NSES of that second is not set and CI\_MFP is true. Otherwise, NBBE shall be zero.

NOTE 3: If the P12s has a CRC4mode of AUTO, the following should be observed: the BBE parameter is not defined for P12s without CRC-4 and the classification of seconds as SES is done differently if there are CRC-4 or not. Consequently, if BBE measurements are done and CRC-4 is not persistently available, the resulting BBE count is unreliable. Also, the SES count is unreliable if the CRC-4 existence is not stable with the pX\_EBC being a mixture of FAS and EDC indications and a threshold value given by the MFP (CRC-4 existence) state at the end of the second. Therefore, care should be taken if PM measurements are done on a P12s with CRC4mode being AUTO.

#### 4.4.2.2 Far-end performance monitoring event function (FPME)

Symbol:

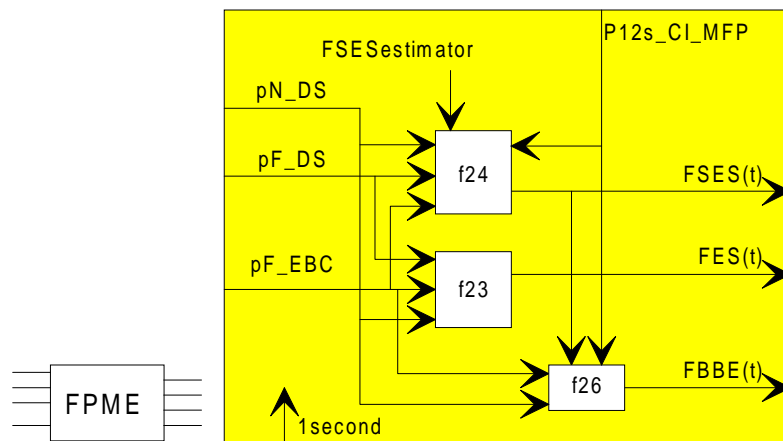

Figure 8: Far-end performance monitoring event function symbol and process diagram

Interfaces:

Table 6: FPME input and output signals

Input(s)	Output(s)
MI_pN_DS	FBBE
MI_pF_DS	FES
MI_pF_EBC	FSES
MI_1second	
P12s_CI_MFP (for P12s signals only)	

Processes:

This function determines for on a per second basis the number of far-end Background Block Errors (BBE), and whether an ES and/or SES occurred.

The EBC and DS performance monitoring primitive signals received from an atomic function are the inputs for the determination of the performance events BBE, ES, SES.

For the case a DS input is not connected, DS shall be assumed to be false. For the case a EBC input is not connected, EBC shall be assumed to be "0".

Figure 8 presents the processes and their interconnect within the Far-end Performance Monitoring Event (FPME) atomic performance monitoring function.

NOTE 1: Far-end represents either those signals that are called "far-end" or those signals that are called "outgoing" (tandem connection specific).

**f23**: a Far-end Errored Second (FES) performance monitoring event signal shall be generated if pF\_DS is set or if pF\_EBC  $\geq 1$ , and if that second is not a Near-end Defect Second (pN\_DS); i.e.:

- $FES \leftarrow (pN\_DS = \text{false}) \text{ and } ((pF\_DS = \text{true}) \text{ or } (pF\_EBC \geq 1))$ .

**f24**: a Far-end Severely Errored Second (FSES) performance monitoring event signal shall be generated if pF\_DS is set or if pF\_EBC  $\geq$  FSEsEstimator (Far-end SES estimator), and that second is not a Near-end Defect Second; i.e.:

- $FSES \leftarrow (pN\_DS = \text{false}) \text{ and } ((pF\_DS = \text{true}) \text{ or } (pF\_EBC \geq \text{FSEsEstimator}))$ .

NOTE 2: The FSEsEstimator value depends on the network layer this FPME function is connected to.

For the case of 2 Mbit/s (P12s) signals, the following FSES definition shall apply:

- FSES ← (pN\_DS = false) and [(pF\_DS = true) or ((pF\_EBC ≥ FSESestimator) and (CI\_MFP = true))].

**SES Estimator:** the SES estimator value is network layer specific and shall be as specified in table 7.

**Table 7: Far-end SES Estimators**

Layer	SES estimator
RS1	Not Applicable
RS4	
RS16	
RS64	
MS1	Refer to subclause 5.3.2 of EN 301 167 [5] subclause 5.3.3.3 of EN 301 167 [5]
MS4	
MS16	
MS64	
VC-4-64c	for further study
VC-4-16c	
VC-4-4c	Refer to subclause 5.2.2 of EN 301 167 [5] subclause 5.2.3.3 of EN 301 167 [5]
VC-4	
VC-3	
VC-2	
VC-12	
VC-11	
P4s	Refer to Annex B/G.826
P31s	
P4e	Refer to Annex B/M.2100 Annex B/G.826
P31e	
P22e	
P12s (CRC) (note)	
NOTE:	Two different values are being specified; for uni-directional performance monitoring defined in ITU-T Recommendation M.2100 [7] the SES estimator is 805, while for bi-directional performance monitoring defined in G.826 the SES estimator is 300. Refer to annex C.

**f26:** the Near-end Background Block Error (FBBE) performance monitoring event signal shall equal pF\_EBC if the FSES of that second is not set and if that second is not a Near-end Defect Second. Otherwise, FBBE is zero.

For the case of 2 Mbit/s (P12s) signals, the following FBBE definition shall apply:

The Near-end Background Block Error (FBBE) performance monitoring event signal shall equal pF\_EBC if the FSES of that second is not set and if that second is not a Near-end Defect Second and CI\_MFP is true. Otherwise, FBBE shall be zero.

NOTE 3: If the P12s has a CRC4mode of AUTO, the following should be observed: the BBE parameter is not defined for P12s without CRC-4 and the classification of seconds as SES is done differently if there are CRC-4 or not. Consequently, if BBE measurements are done and CRC-4 is not persistently available, the resulting BBE count is unreliable. Also, the SES count is unreliable if the CRC-4 existence is not stable with the pX\_EBC being a mixture of FAS and EDC indications and a threshold value given by the MFP (CRC-4 existence) state at the end of the second. Therefore, care should be taken if PM measurements are done on a P12s with CRC4mode being AUTO.



## 4.4.2.3 Uni-directional availability filter function (AvFu)

Symbol:

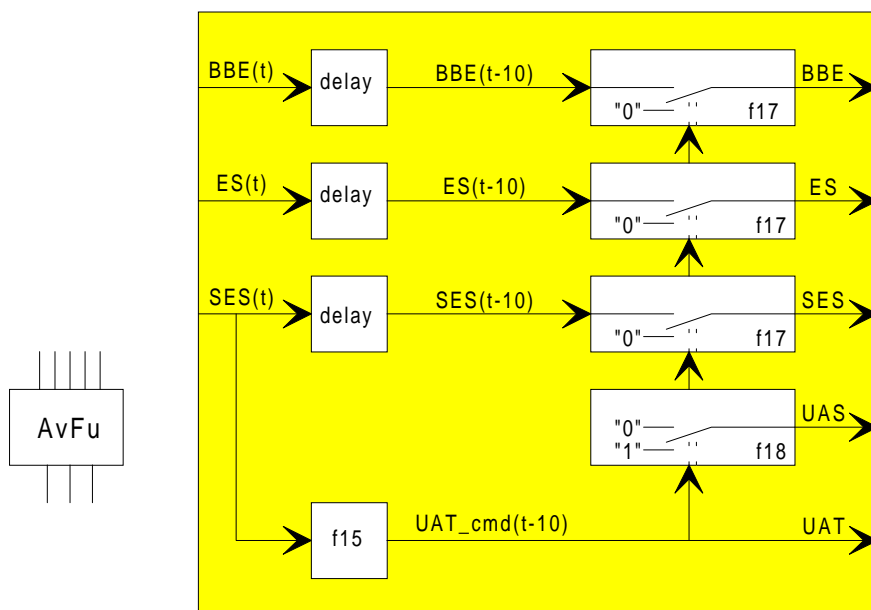

Figure 9: Uni-directional availability filter function symbol and process diagram

Interfaces:

Table 8: AvFu input and output signals

Input(s)	Output(s)
BBE(t)	BBE
ES(t)	ES
SES(t)	SES
	UAS
	UAT

Processes:

This function determines whether a one second is uni-directionally available or unavailable, and passes through the (ES, SES, BBE) input signal's value for seconds in available time. The input signal value in seconds in unavailable time is not output, instead the value "0" is output. This function is applicable for near-end, far-end, near-end outgoing and far-end outgoing information processing.

NOTE: UATcmd indicates (functionally) if a second is available or unavailable.

Based on the SES event indications, the start and end of UAT is determined. The BBE, ES and SES information is delayed by 10 seconds to maintain alignment in time of this information and the UAT indication (UATcmd).

For the case the BBE(t) input is not connected, BBE(t) shall be assumed to be "0". For the case the ES(t) input is not connected, ES(t) shall be assumed to be "0". For the case the SES(t) input is not connected, SES(t) shall be assumed to be "0".

**f15:** unavailable Time command (UAT\_cmd) shall be set if ten consecutive SES's are detected. UAT\_cmd shall be cleared after ten contiguous seconds not being SES.

A change of the UAT\_cmd shall be reported.

**delay:** the BBE, ES and SES event signals shall be delayed by 10 seconds to align them with the UATcmd signal for further processing in the history atomic performance monitoring functions.

**f17:** the BBE(t-10), ES(t-10) and SES(t-10) event signals shall be output in available time; i.e. if UATcmd is false. Otherwise, the value "0" shall be output.

**f18:** in available time (i.e. if UATcmd is false), the value "0" shall be output via UAS. Otherwise (UATcmd is true), the value "1" shall be output.

#### 4.4.2.4 Bi-directional availability filter function (AvFb)

Symbol:

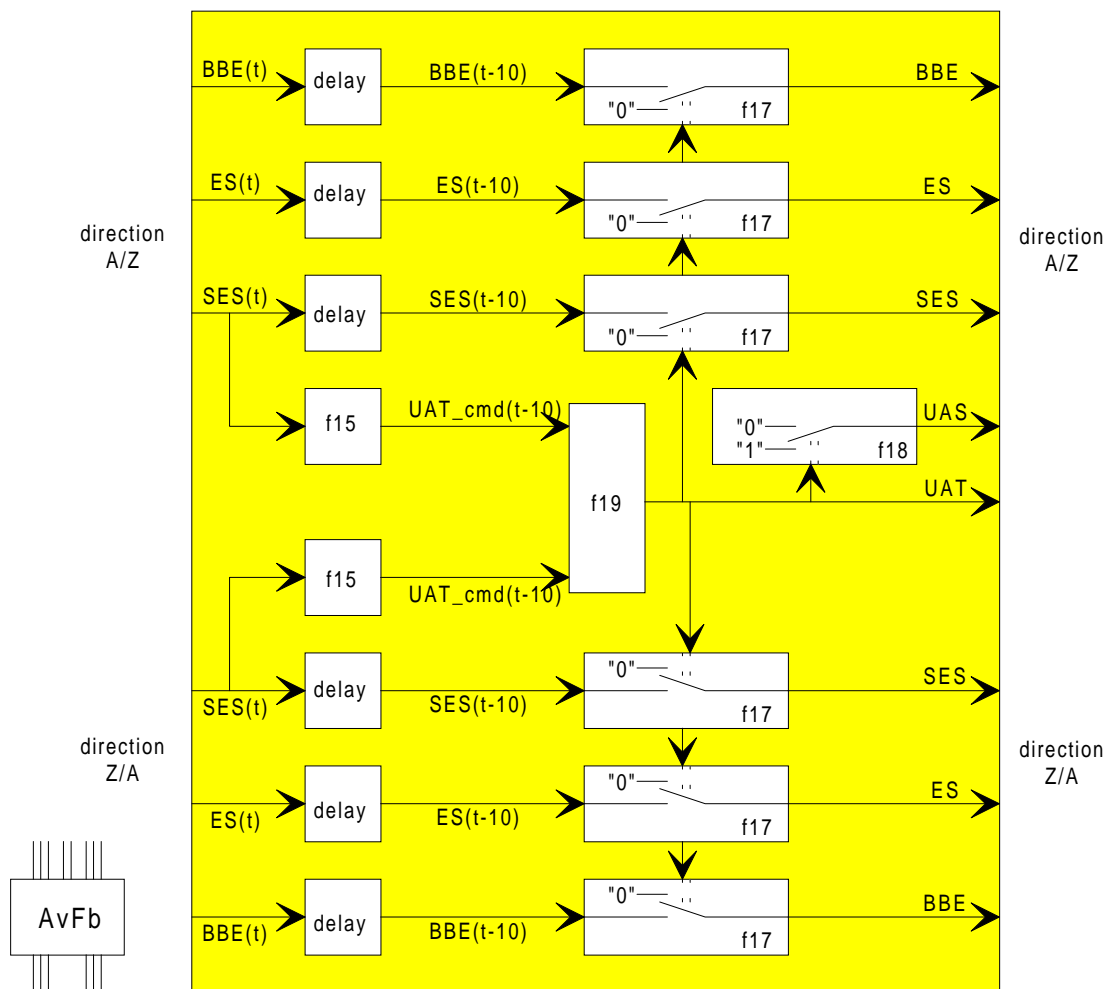

Figure 10: Bi-directional availability filter function symbol and process diagram

Interfaces:

Table 9: AvFb input and output signals

Input(s)	Output(s)
A/Z_BBE(t)	A/Z_BBE
A/Z_ES(t)	A/Z_ES
A/Z_SES(t)	A/Z_SES
Z/A_BBE(t)	Z/A_BBE
Z/A_ES(t)	Z/A_ES
Z/A_SES(t)	Z/A_SES
	UAT
	UAS

**Processes:**

This function determines whether a one second is bi-directionally available or unavailable, and passes through the (ES, SES, BBE) input signal's value in seconds in available time. The input signal value in seconds in unavailable time is not output, instead the value "0" is output.

NOTE 1: UATcmd indicates (functionally) if a second is available or unavailable.

Based on the SES event indications, the start and end of UAT is determined. The BBE, ES and SES information is delayed by 10 seconds to maintain alignment in time of this information and the UAT indication (UATcmd).

NOTE 2: The A/Z and Z/A direction indication is used here instead of the more common near-end and far-end indications to support performance monitoring at both the trail termination point and an intermediate point along the trail. Refer to annex B.

For the case the BBE(t) input is not connected, BBE(t) shall be assumed to be "0". For the case the ES(t) input is not connected, ES(t) shall be assumed to be "0". For the case the SES(t) input is not connected, SES(t) shall be assumed to be "0".

**f15:** unavailable Time command (UAT\_cmd) shall be set if ten consecutive SES's are detected. UAT\_cmd shall be cleared after ten contiguous seconds not being SES.

**f19:** bi-directional unavailable time shall be declared if either the A/Z direction is unavailable or the Z/A direction is unavailable:

- $UAT \leftarrow A/Z\_UAT\_cmd(t-10) \text{ or } Z/A\_UAT\_cmd(t-10)$ .

A change of the UAT shall be reported.

**delay:** the BBE, ES and SES signals are delayed by 10 seconds to align them with the UATcmd signal for further processing in the history atomic performance monitoring functions.

**f17:** the BBE(t-10), ES(t-10) and SES(t-10) signals shall be output in available time; i.e. if UAT is false. Otherwise, the value "0" shall be output.

**f18:** in available time (i.e. if UAT is false), the value "0" shall be output via UAS. Otherwise (UAT is true), the value "1" shall be output.

#### 4.4.2.5 Delay filter function (Delay)

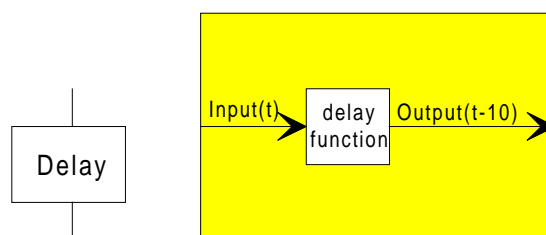
**Symbol:**

**Figure 11: Delay filter function symbol and process diagram**

**Interfaces:**

**Table 10: Delay input and output signals**

Input(s)	Output(s)
Input(t)	Output (t-10)

**Processes:**

This function delays the input signal (which is not subject to "availability" processing) by 10 seconds to align it with the performance monitoring time base which is 10 seconds delayed from the time of day.

**Delay function:** the input signal (e.g. PJE) shall be delayed by 10 seconds to align them with the performance monitoring time base signal for further processing in the history atomic performance monitoring functions.

### 4.4.3 Performance monitoring history functions

#### 4.4.3.1 Current 15m register function

**Symbol:**

Figure 12: Current 15 minute register process symbol and process diagram

**Interfaces:**

Table 11: Current 15m input and output signals

Input(s)	Output(s)
RegisterInput	CurrentCNT15m
PMclock15m	SuspectFlag
PMclock	ElapsedTime

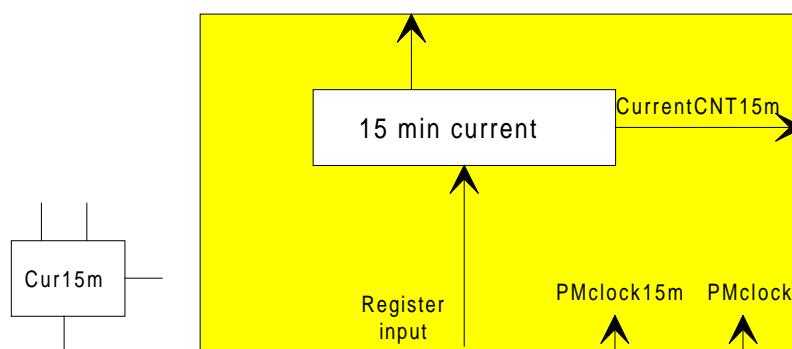
**Processes:**

This function accumulates the RegisterInput values over periods of 15 minutes.

NOTE 1: The effect of the administrativeState attribute defined in the information model on the behaviour of the current 15 minute register process is for further study.

**Current register:** the 15 minute current register shall accumulate the content of the register with the RegisterInput value. The current register shall be large enough to accumulate all integer numbers from zero to a particular maximum value, which determines the minimum register size for that parameter. The maximum value shall be at least the nominal count of an interval. When the maximum value of the register is reached, the register shall remain at that maximum value until it is reset, or transferred.

NOTE 2: Current data may be lost during failure conditions within the equipment and its power feeding.

The size of the current register shall be able to accommodate at least the counts as specified in table 12:

**Table 12: 15 minute register minimum size**

Layer	Current register size			
	ES	BBE (see note 3)	SES (see note 4)	UAS
RS1	900	1 080 000	810	900
RS4		under study		
RS16				
RS64				
MS1		25 920 000		
MS4		103 680 000		
MS16		414 720 000		
MS64		under study		
VC-4-64c				
VC-4-16c				
VC-4-4c		2 160 000		
VC-4				
VC-3				
VC-2		540 000		
VC-12				
VC-11				
P4s		2 160 000		
P31s				
P4e		-		
P31e		-		
P22e	-			
P12s (FAS)	-			
P12s (CRC)	270 000 (1) 724 500 (2)			
<p>NOTE 1: This value is applicable for the case of a SES estimator of 30 % (see G.826).</p> <p>NOTE 2: This value is applicable for the case of a SES estimator of 80.5 % (see ITU-T Recommendation M.2100 [7]).</p> <p>NOTE 3: The maximum number of background block errors is obtained when the SES threshold is set to the number of blocks per second (e.g. 8 000 for RS<sub>n</sub>). In that case the maximum number of background block errors per second is equal to the number of blocks per second minus 1. For the case the SES threshold is 30 % of the EBs per second, the maximum number of background block errors is equal to 30 % of blocks per second minus 1. E.g. for a VC-4 with 8 000 blocks per second, the maximum number of background block errors per second is <math>30\% \times 8\,000 - 1 = 2\,399</math>. Per 15 minute period, the maximum number of BBEs is <math>900 \times 2\,399 = 2\,159\,100</math>.</p> <p>NOTE 4: SES will be counted as long as it is not in unavailable time. This explains the deviation of 10 % of the maximum number of seconds. To avoid unavailable time after each ninth second, a second must follow in which the SES threshold is not reached.</p>				

**Current register suspect indication:** the current register suspect flag will be set to true to indicate that the data stored in the register is incomplete or invalid for the current accumulation interval. The suspect flag shall be set to true under the following conditions:

- elapsed time deviates more than 10 seconds of the nominal time (900); this includes a preset of the real time clock to a value deviating more than 10 seconds from the current time, lost PM data in equipment, and initialization of 15min register.

NOTE 3: This allows for small corrections to the real time clock without marking periods as suspected.

**Current register elapsed time:** the current register shall contain an elapsed time indication, indicating the number of seconds of the current interval for which the performance indicator is processed into the performance parameter. The current register elapsed time shall be able to indicate at least the elapsed time of the nominal interval; i.e. 900 seconds. When the maximum value of a elapsed time register is reached, the register shall remain at that maximum value until it is reset, or transferred.

**End of accumulation period:** at the end of the 15 minute accumulation period, the contents of the current register shall be transferred to the recent register and then the current register shall be initialized before the start of the next 15 minute accumulation period.

NOTE 4: "Zero suppression" is a technique to reduce the amount of information to be communicated from the NE to the network element management system. In the past this communication reduction technique has been associated with the storage of PM information within the NE. Such relation is not necessarily present, and as such is not specified in the present document. The zero suppression technique is assumed to be a characteristic of the information exchange process between NE and EMS and is defined within the information model.

If the NE-RTC (and consequently the PMclock) is set to a time outside the current interval, the end of the 15 minute accumulation period shall be assumed, and the actions as specified above shall be performed.

**Initialization of current register at start of 15 minute period:** the time stamp shall be as specified under current register time stamp, elapsed time shall be "0", suspect indication shall be "false", and current register count shall be "0".

**Report current register:** it shall be possible to report the value of the current register when requested.

**Current 15 minute register initialization:** at connection of the 15 minute register input (i.e. at start of processing), the current register shall be initialized as follows: elapsed time is "0", suspect indication is "false", and register count is "0".

#### 4.4.3.2 Recent 15m register function

**Symbol:**

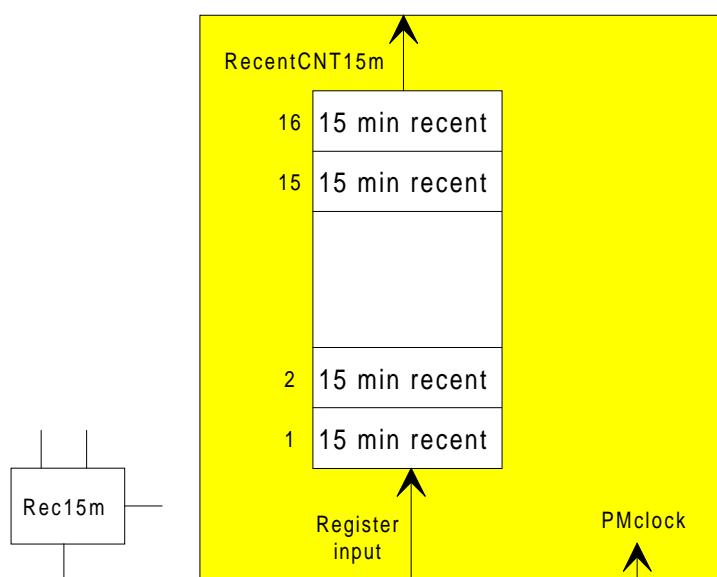

**Figure 13: Recent 15 minute register process symbol and process diagram**

**Interfaces:**

**Table 13: Recent 15m input and output signals**

Input(s)	Output(s)
RegisterInput	RecentCNT15m[1:16]
PMclock15m	SuspectFlag
PMclock	ElapsedTime

**Processes:**

This function stores the RegisterInput values in one of the 16 recent registers.

**Recent registers:** at the end of the current 15 minute period, the current register input data shall be transferred to the recent #1 register. Before the data is transferred, any data in the recent #i (i = 2...15) registers shall be transferred to the recent #(i + 1) registers. The data in recent #16 register shall be discarded.

**Recent register time stamp:** the recent register shall contain a time stamp indicating the end of the recent interval. The time stamp shall indicate an end time at ¼ hour intervals (Day:Month:Year:Hour:Minute). The time stamp shall have an accuracy of 1 second relative to the NE-RTC.

Pre-setting the NE-RTC shall have no effect on the time stamp in the recent registers.

**Report recent registers:** it shall be possible to report the value of the 16 recent registers when requested.

**Recent 15 minute register initialization:** at connection of the 15 minute register input (i.e. at start of processing), the 16 recent registers shall be initialized as follows: time stamp is 0000:00:00:00:00, elapsed time is "0", suspect indication is "true", and register count is "0".

#### 4.4.3.3 Current 24h register function

**Symbol:**

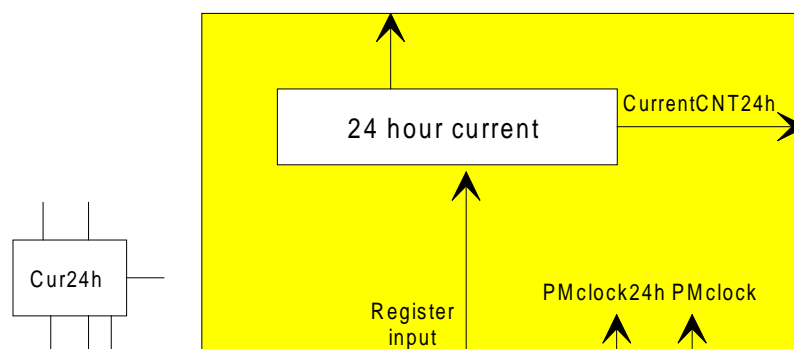

**Figure 14: Current 24 hour register process symbol and process diagram**

**Interfaces:**

**Table 14: Current 24h input and output signals**

Input(s)	Output(s)
RegisterInput	CurrentCNT24h
PMclock24h	SuspectFlag
PMclock	ElapsedTime

**Processes:**

This function accumulates the RegisterInput values over periods of 24 hours.

NOTE 1: The effect of the administrativeState attribute defined in the information model on the behaviour of the current 24 hour register process is for further study.

**Current register:** the 24 hour current register shall accumulate the content of the register with the RegisterInput value. The current register shall be large enough to accumulate all integer numbers from zero to a particular maximum value, which determines the minimum register size for that parameter. The maximum value shall be at least the nominal count of an interval. When the maximum value of the register is reached, the register shall remain at that maximum value until it is reset, or transferred.

NOTE 2: Current data may be lost during failure conditions within the equipment and its power feeding.

NOTE 3: It is up to the NE implementation to update the register counts. It is not required that it be done on a second by second basis. An update once every 15 minutes would be sufficient.

The size of the register counter shall be able to accommodate at least the counts as specified in table 15:

**Table 15: 24 hour register minimum size**

Layer	Current register size				
	ES	BBE (see note 3)	SES (see note 4)	UAS	PJE
RS1	86 400	103 680 000	77 760	86 400	-
RS4		under study			-
RS16					-
RS64					-
MS1		25 920 000			-
MS4		103 680 000			-
MS16		414 720 000			-
MS64		under study			-
VC-4-64c					65 535
VC-4-16c					
VC-4-4c		207 360 000			
VC-4					
VC-3					-
VC-2		51 840 000			-
VC-12					-
VC-11					-
P4s		207 360 000			-
P31s					-
P4e		-			-
P31e		-			-
P22e		-			-
P12s (FAS)		-			-
P12s (CRC)		25 920 000 (1) 69 552 000 (2)			-

NOTE 1: This value is applicable for the case of a SES estimator of 30 % (see G.826).  
NOTE 2: This value is applicable for the case of a SES estimator of 80.5 % (see ITU-T Recommendation M.2100 [7]).  
NOTE 3: The maximum number of background block errors is obtained when the SES estimator is set to the number of blocks per second (e.g. 8 000 for RS<sub>n</sub>). In that case the maximum number of background block errors per second is equal to the number of blocks per second minus 1.  
For the case the SES estimator is 30 % of the EBs per second, the maximum number of background block errors is equal to 30 % of blocks per second minus 1. E.g. for a VC-4 with 8 000 blocks per second, the maximum number of background block errors per second is 30 % x 8 000 - 1 = 2 399. Per 24 hour period, the maximum number of BBEs is 86 400 x 2 399 = 207 273 600.  
NOTE 4: SES will be counted as long as it is not in unavailable time. This explains the deviation of 10 % of the maximum number of seconds. To avoid unavailable time after each ninth second, a second must follow in which the SES threshold is not reached.

**Current register suspect indication:** the current register suspect flag will be set to true to indicate that the data stored in the register is incomplete or invalid for the current accumulation interval. The suspect flag shall be set to true under the following conditions:

- elapsed time deviates more than 10 seconds of the nominal time (900); this includes a preset of the real time clock to a value deviating more than 10 seconds from the current time, lost PM data in equipment, and initialization of 15min register.

NOTE 4: This allows for small corrections to the real time clock without marking periods as suspected.

**Current register elapsed time:** the current register shall contain an elapsed time indication, indicating the number of seconds of the current interval for which the performance indicator is processed into the performance parameter. The current register elapsed time shall be able to indicate at least the elapsed time of the nominal interval; i.e. 86 400 seconds. When the maximum value of a elapsed time register is reached, the register shall remain at that maximum value until it is reset, or transferred.

**End of accumulation period:** at the end of the 24 hour accumulation period, the contents of the current register shall be transferred to the recent register and then the current register shall be initialized before the start of the next 24 hour accumulation period.



If the NE-RTC (and consequently the PMclock) is set to a time outside the current interval, the end of the 24 hour accumulation period shall be assumed, and the actions as specified above shall be performed.

**Initialization of current register at start of 24 hour period:** the elapsed time shall be "0", suspect indication shall be "false", and current register count shall be "0".

**Report current register:** it shall be possible to report the value of the current register when requested.

**Current 24 hour register initialization:** at connection of the 24 hour register input (i.e. at start of processing), the current register shall be initialized as follows: elapsed time is "0", suspect indication is "false", and register count is "0".

#### 4.4.3.4 Recent 24h register function

**Symbol:**

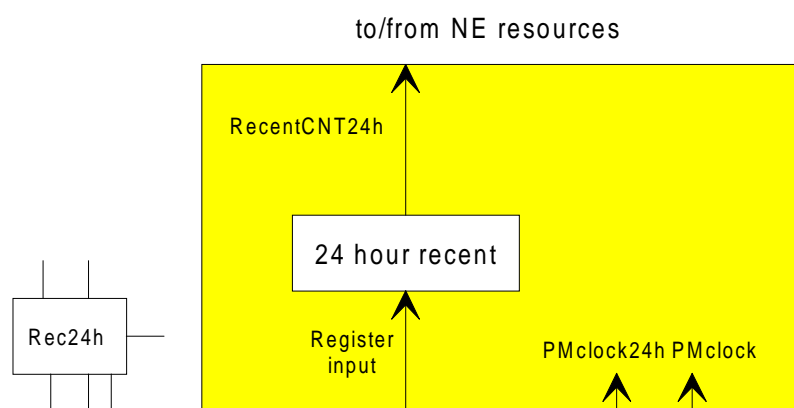

**Figure 15: Recent 24 hour register process symbol and process diagram**

**Interfaces:**

**Table 16: Recent 24h input and output signals**

Input(s)	Output(s)
RegisterInput	RecentCNT24h
PMclock24h	SuspectFlag
PMclock	ElapsedTime

**Processes:**

This function stores the RegisterInput value in the recent register.

**Recent register:** at the end of the current 24 hour period, the current register input data shall be transferred to the recent register. Before the data is transferred, any data in the recent register shall be discarded.

**Recent register time stamp:** the recent register shall contain a time stamp indicating the end of the recent interval. The time stamp shall indicate an end time at  $\frac{1}{4}$  hour intervals (Day:Month:Year:Hour:Minute). The time stamp shall have an accuracy of 1 second relative to the NE-RTC.

**Report recent registers:** it shall be possible to report the value of the recent register when requested.

Pre-setting the NE-RTC shall have no effect on the time stamp in the recent register.

**Recent 24 hour register initialization:** at connection of the 24 hour register input (i.e. at start of processing), the recent register shall be initialized as follows: time stamp is 0000:00:00:00:00, elapsed time is "0", suspect indication is "true", and register count is "0".

#### 4.4.3.5 Begin/End of UAT event generation function

Symbol:

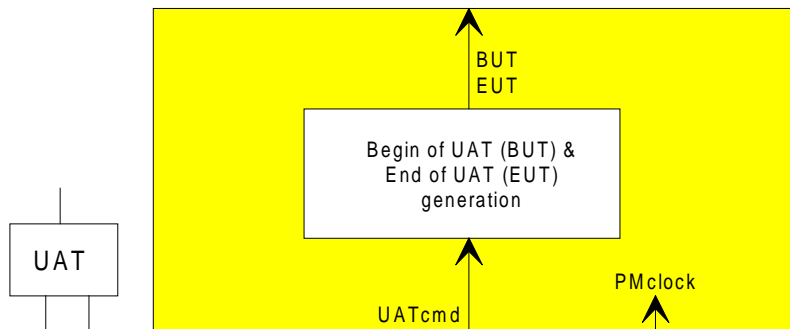

Figure 16: Begin/End of UAT event generation symbol and process diagram

Interfaces:

Table 17: Begin/End of UAT event generation input and output signals

Input(s)	Output(s)
UATcmd PMclock	BUT EUT

Processes:

The Begin/End of UAT event generation process (figure 16) will generate events indicating UAT state changes.

NOTE: The effect of the administrativeState attribute defined in the information model on the behaviour of the BUT/EUT event generation process is for further study.

If UATcmd is activated, a timestamped Begin of UAT (BUT) event shall be generated. If UATcmd clears, a timestamped End of UAT (EUT) event shall be generated. The timestamp shall indicate day:month:year:hour:minute:second. The time stamp shall have an accuracy of 1 second relative to the NE-RTC.

The BUT and EUT events shall be reported and logged via the Management Application Function.

#### 4.4.3.6 CSES log function

Symbol:

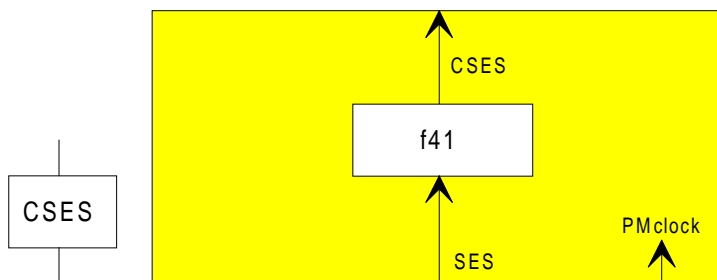

Figure 17: CSES symbol and process diagram

**Interfaces:****Table 18: CSES input and output signals**

Input(s)	Output(s)
SES PMclock	CSES

**Processes:**

*f41*: the function shall determine if a SES is part of a CSES as specified in the CSES process depicted in figure 18. A CSES period is a period of N consecutive SESs, which are not within a period of unavailable time. While the error burst may be on the border of two consecutive seconds, N = 2 is not considered as consecutive SESs. Therefore N is to be  $\geq 3$ . While 10 consecutive SESs result in UAT, the maximum length of a CSES period is 9 seconds. This is assumed in figure 18 ("CNT==3") and the fact that the SES input signal has passed through the Availability Filter function forcing SES indications to zero during a period of UAT.

The function shall generate a timestamped CSES event when an CSES period is detected. The timestamp shall indicate the start of the CSES period in day:month:year:hour:minute:second.

NOTE: The effect of the administrativeState attribute defined in the information model on the behaviour of the CSES event generation process is for further study.

The CSES events shall be reported and logged via the Management Application Function.

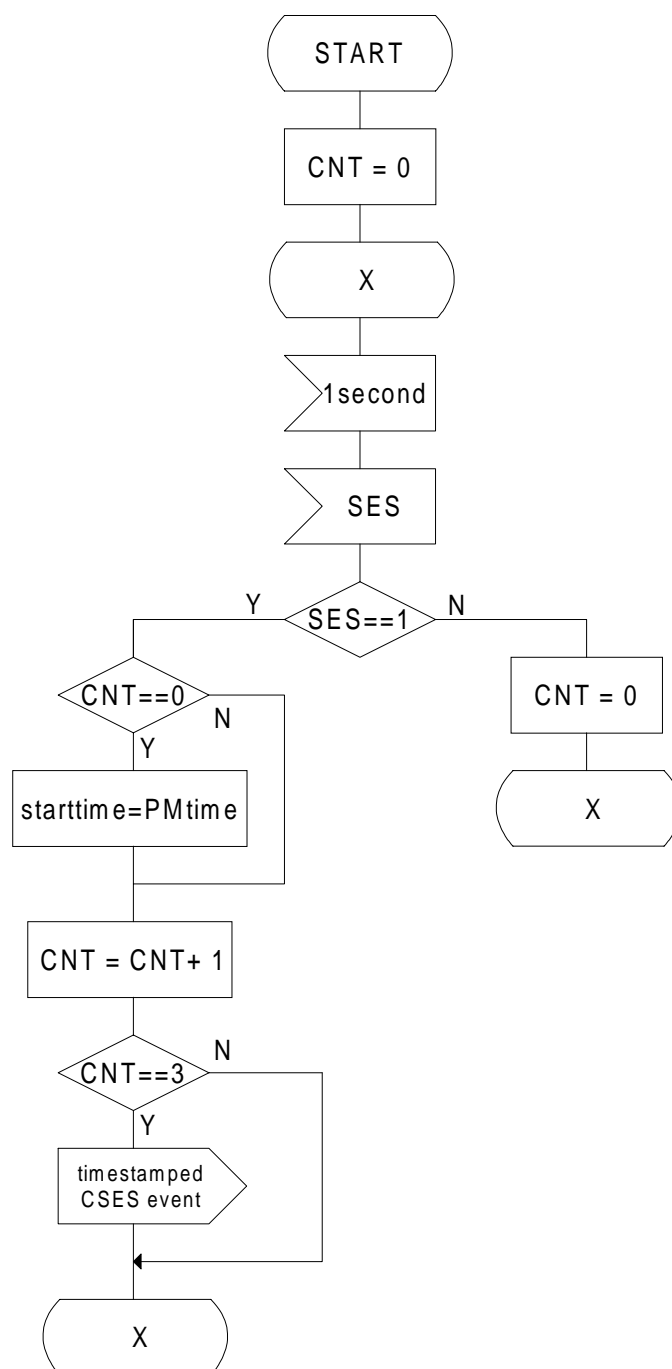

Figure 18: CSES process

#### 4.4.4 Performance monitoring thresholding functions

A thresholding mechanism can be used to generate an autonomous event report when the performance of a transport entity falls below a predetermined level. The general strategy for the use of thresholds is described in ITU-T Recommendation M.20 [24]. Specific information is contained in ITU-T Recommendations M.2100 [7], M.2101.1 [8], M.2120 [9] and EN 301 167 [5].

Two threshold mechanisms are defined:

- TR only - one threshold value is defined; if the event count reaches or exceeds the threshold value, the threshold state is set to true and a threshold report is generated. The threshold state is implicitly reset (to false) at the end of the accumulation period. This mechanism is applicable for 15 minute and 24 hour accumulation periods;

- TR-RTR - two threshold values (set, reset) are defined; if the event count reaches or exceeds the set threshold value and the threshold state is false, the threshold state is set to true and a threshold report is generated. If the threshold state is true, the threshold state is reset (to false) and a reset threshold report is generated at the end of a following accumulation period in which the event count is less than the reset threshold value and there was not an unavailable period in the accumulation period. This mechanism is applicable for 15 minute accumulation periods.

#### 4.4.4.1 Single level thresholding function (ThrFs)

Symbol:

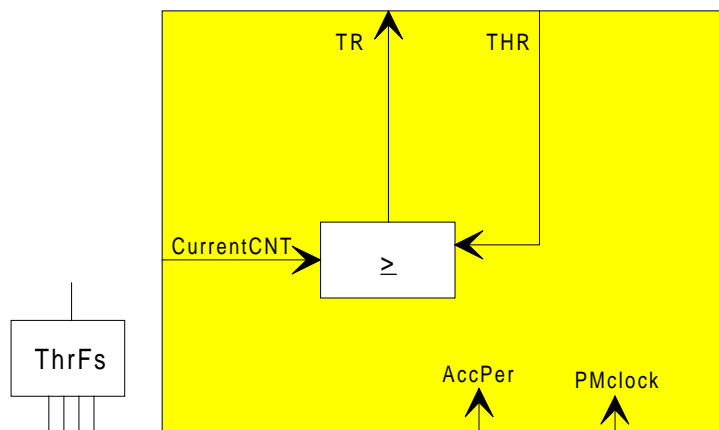

Figure 19: Single level thresholding function process symbol and process diagram

Interfaces:

Table 19: ThrFs input and output signals

Input(s)	Output(s)
CurrentCNT PMclock AccPer THR	TR

Processes:

A single level thresholding mechanism can be used to generate an autonomous event report when the performance of a transport entity falls below a predetermined level. This mechanism is applicable for 15 minute and 24 hour accumulation periods.

The TR only process shall operate as specified in figure 20. The threshold state shall be set to true if the event count reaches or exceeds the threshold value and the threshold state is false. If the threshold state is true, the threshold state shall be reset to false at either the end of the accumulation period, or when the threshold value is changed within the current accumulation period to a value which is larger than the current event count.

If the threshold state is false, the threshold state shall be set to true when the threshold (THR) value is modified to a value that is less or equal the current event count. If the threshold state is true, the threshold state shall be set to false when the threshold value is modified to a value that is larger than the current event count.

A threshold report (TR) shall be generated when the threshold state changes from false to true.

A threshold can be crossed at any second within the accumulation period. The function shall detect a 15-minute threshold crossing within 1 minute of its occurrence, and a 24 hour threshold crossing within 15 minutes of its occurrence. The 15 minute threshold report shall indicate the PM-second in which the threshold is reached or exceeded. The 24 hour threshold report shall indicate the moment of threshold crossing detection (that might be up to 15-minutes after the actual threshold crossing). The time stamp shall have a resolution of 1 second relative to the NE-RTC.

When a threshold is crossed, the function shall not automatically reset the register, but shall continue to the end of the accumulation period.

The detailed functioning of the threshold mechanisms is explained in EN 301 167 [5] and in subclause 2.3 of ITU-T Recommendation M.2120 [9]. Refer to subclause 4.5.14 for a specification of 15 minute and 24 hour TR and RTR threshold ranges and defaults.

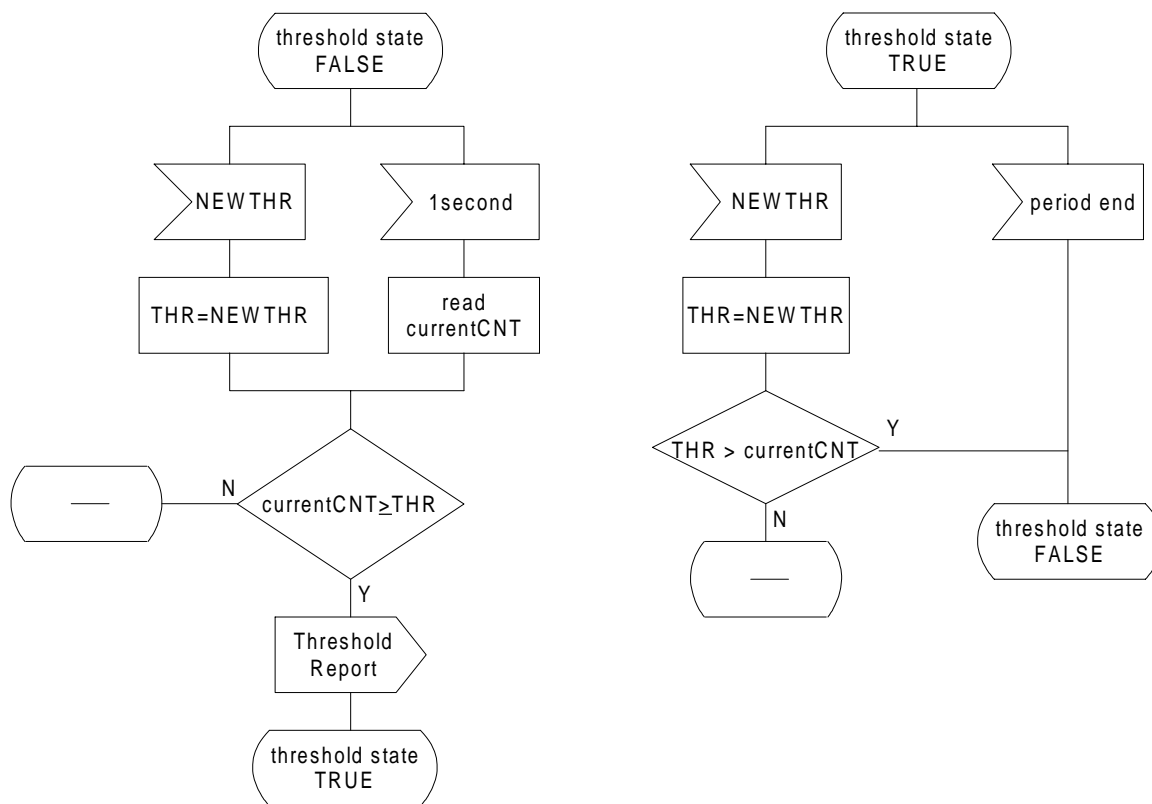

Figure 20: TR only process

4.4.4.2 Dual level thresholding function (ThrFd)

Symbol:

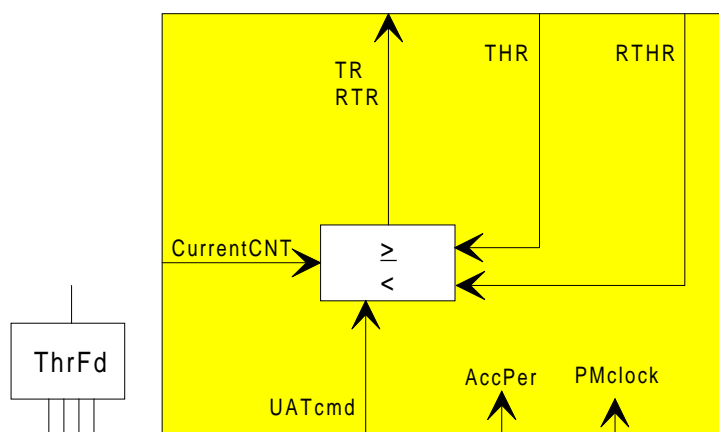

Figure 21: Dual level thresholding function process symbol and process diagram

**Interfaces:****Table 20: ThrFd input and output signals**

Input(s)	Output(s)
CurrentCNT PMclock THR RTHR UATcmd	TR RTR

**Processes:**

A two level thresholding mechanism can be used to generate autonomous event reports when the performance of an transport entity falls below a predetermined level and subsequently recovers. This mechanism is applicable for 15 minute accumulation periods.

The TR/RTR process shall operate as specified in figure 22. The threshold state shall be set to true if the event count reaches or exceeds the set threshold value and the threshold state is false. If the threshold state is true, the threshold state shall be reset to false at the end of a (following) accumulation period in which the event count is less than or equal to the reset threshold value and there was not an unavailable period (UATcmd is true) in the accumulation period.

If the threshold state is false, the threshold state shall be set to true when the threshold (THR) value is modified to a value that is less or equal the current event count. If the threshold state is true, the threshold state shall be maintained on a change of the threshold (THR) value.

NOTE 1: The behaviour on a change of threshold value is compliant with the specification in ITU-T Recommendation M.2120 [9] and not with ITU-T Recommendation Q.822 [23]. Subclause 4.3.2.13 of ITU-T Recommendation Q.822 [23] specifies that for the case the threshold state is true and the threshold value (THR) is changed to a value larger than the current event count a RTR should be generated and the threshold state should be set to false.

A threshold report (TR) shall be generated when the threshold state changes from false to true. A reset threshold report (RTR) shall be generated when the threshold state changes from true to false.

A set threshold can be crossed at any second within the accumulation period. The function shall recognize a 15-minute threshold crossing within 1 minute of its occurrence. The threshold report (TR) and reset threshold report (RTR) shall indicate the moment of crossing and shall have an accuracy of 1 second relative to the NE-RTC.

When a set threshold is crossed, the function shall not automatically reset the register, but shall continue to the end of the accumulation period.

The detailed functioning of the threshold mechanisms is explained in EN 301 167 [5] and in subclause 2.3 of ITU-T Recommendation M.2120 [9]. Refer to subclause 4.5.14 for a specification of 15 minute and 24 hour TR and RTR threshold ranges and defaults.

NOTE 2: ITU-T Recommendation M.2120 [9] does not specify that the occurrence of an UAT period prevents the generation of RTR. As such there is a discrepancy between the behaviour defined by ITU-T Recommendation M.2120 [9] and EN 301 167 [5].

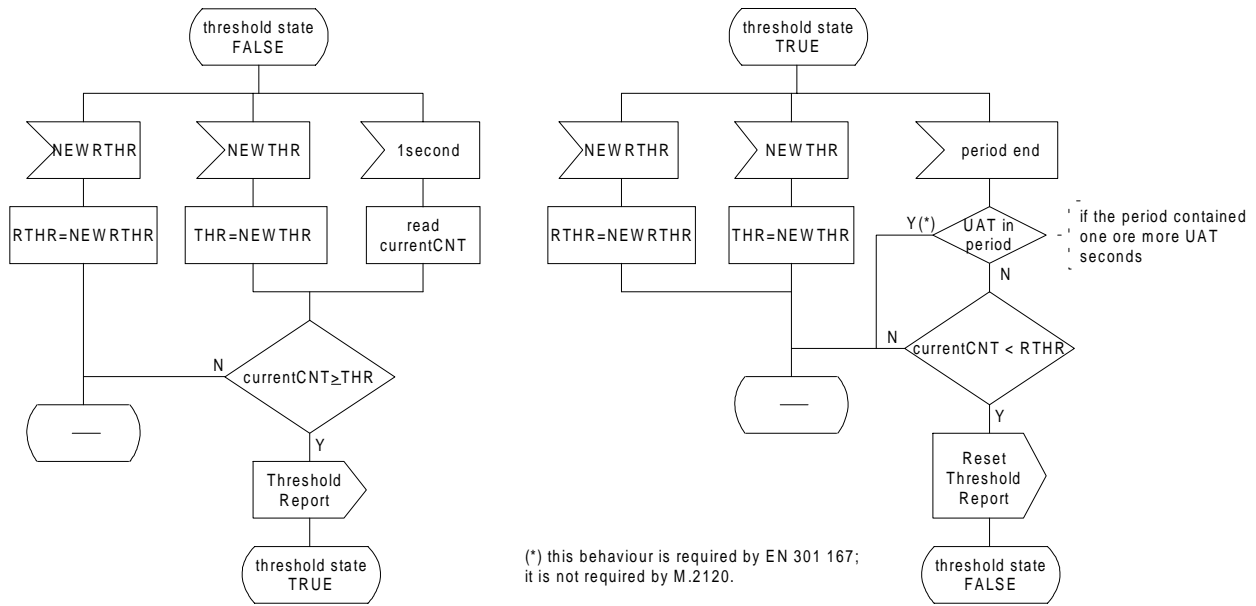

Figure 22: TR/RTR process

#### 4.4.5 Performance monitoring packages

With the PMFs defined above, a number of performance monitoring packages (PM compound functions) are defined. These represent the performance monitoring specifications in ITU-T Recommendations G.826, M.2100 [7] and M.2101.1 [8]. Other packages – including a different set of PMFs - can be defined also; examples of some of those other packages are presented in annex B.



#### 4.4.5.1 ITU-T Recommendations M.2100/M.2101.1 Near-end (A/Z direction) maintenance (uni-directional) package

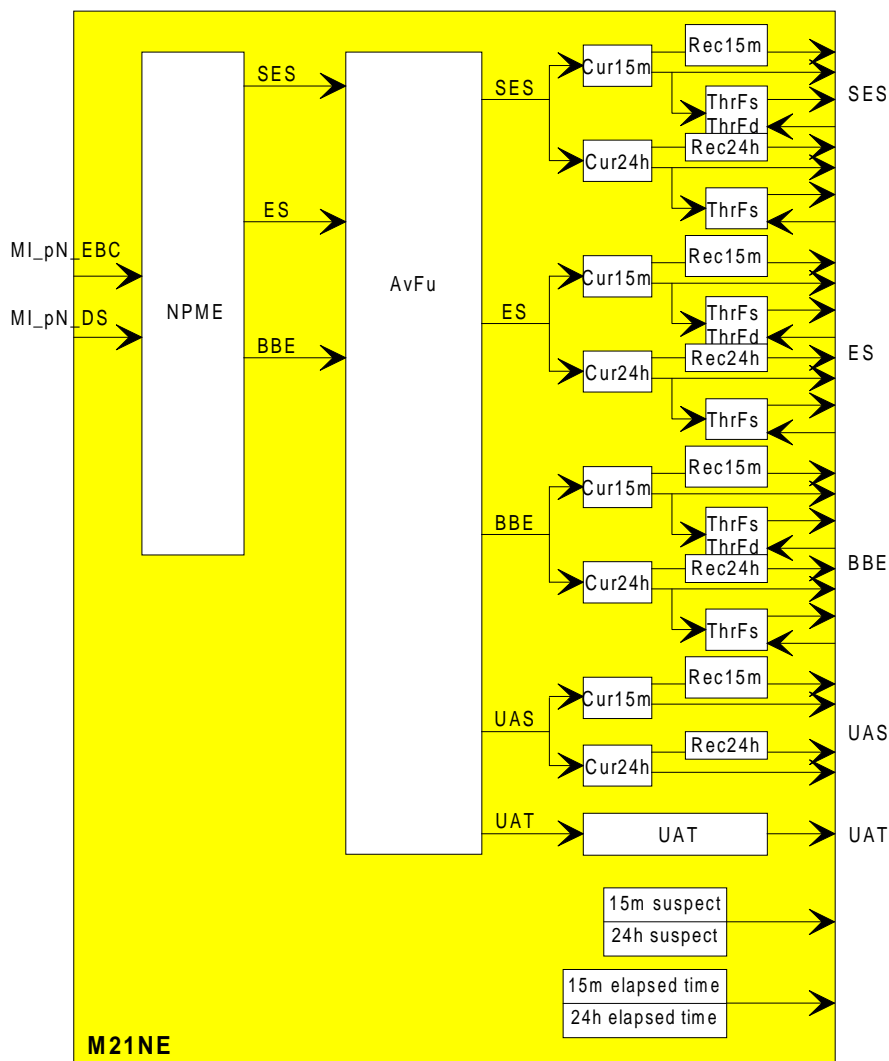

**Figure 23: M.2100/M.2101.1 near-end performance monitoring**

The M.2100/2101 near-end (A/Z direction) maintenance (uni-directional) package (M21NE) (figure 23) shall compute UAS, ES, SES, and BBE over periods of 15 minute and 24 hour for one direction of transmission using near-end information (A/Z).

The package can be used at trail termination points to monitor the quality in the incoming direction, and at connection points (via a non-intrusive monitor) to monitor the quality of the trail portion in the incoming direction of the signal passing through.

UAT events shall be computed and logged.

During a period of unavailable time the counting of BBEs, ESs, and SESs is stopped.

Performance event (BBE, ES, SES) counts shall be monitored for a threshold crossing; 15 minutes with either the single or dual thresholding and 24 hour with single thresholding.

#### 4.4.5.2 ITU-T Recommendations M.2100/M.2101.1 far-end (Z/A direction) maintenance (uni-directional) package

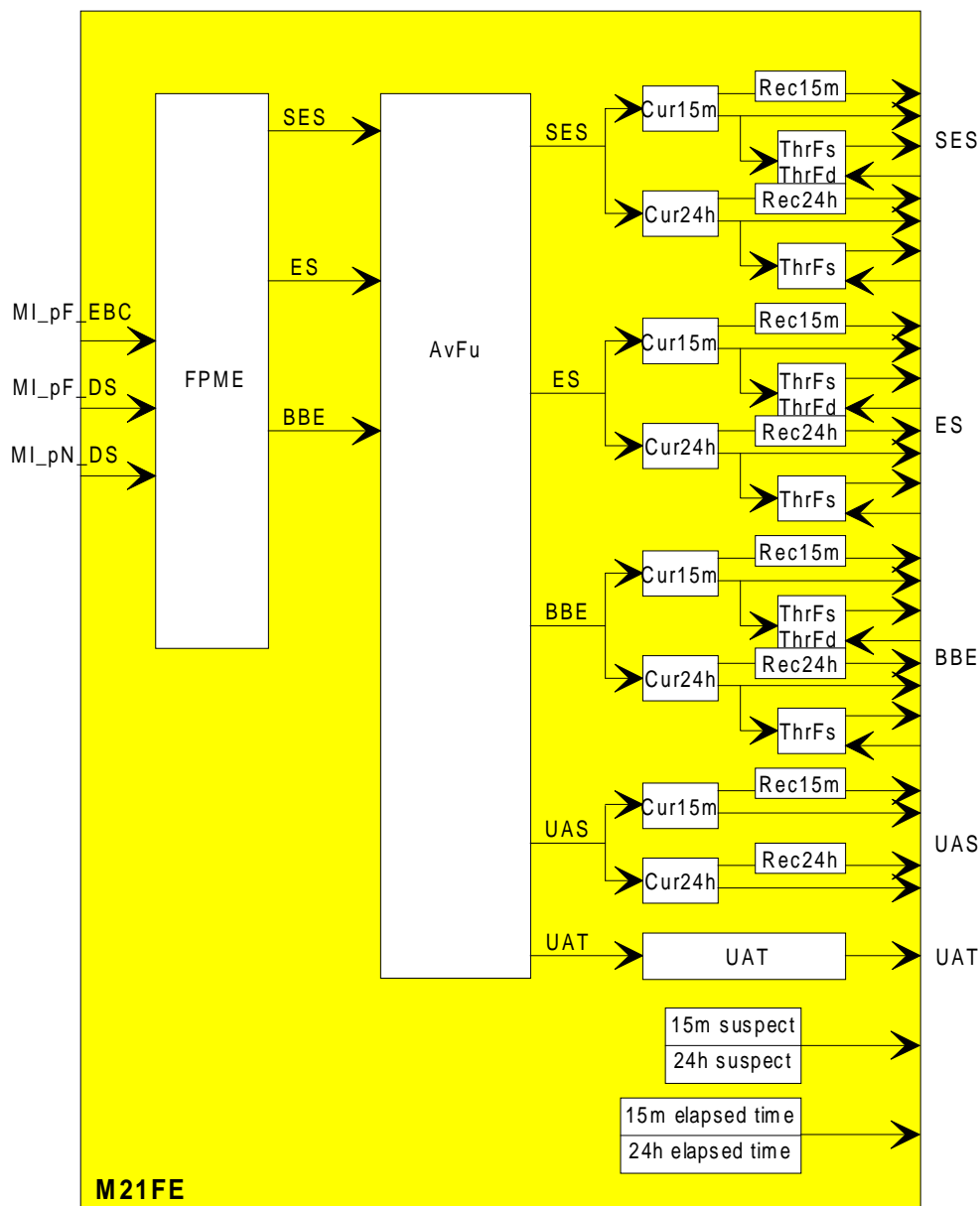

**Figure 24: M.2100/M.2101.1 far-end performance monitoring**

The M.2100/2101 far-end (Z/A direction) maintenance (uni-directional) package (M21FE) (figure 24) shall compute UAS, ES, SES, and BBE over periods of 15 minute and 24 hour for one direction of transmission using far-end information (Z/A).

The package can be used at trail termination points to monitor the quality in the outgoing direction, and at connection points (via a non-intrusive monitor) to monitor the quality of the end-to-end trail in the reverse direction of the signal passing through.

UAT events shall be computed and logged.

During a period of unavailable time the counting of BBEs, ESs, and SESs is stopped.

Performance event (BBE, ES, SES) counts shall be monitored for a threshold crossing; 15 minutes with either the single or dual thresholding and 24 hour with single thresholding.

#### 4.4.5.3 ITU-T Recommendation G.826 error performance (bi-directional) package at trail termination

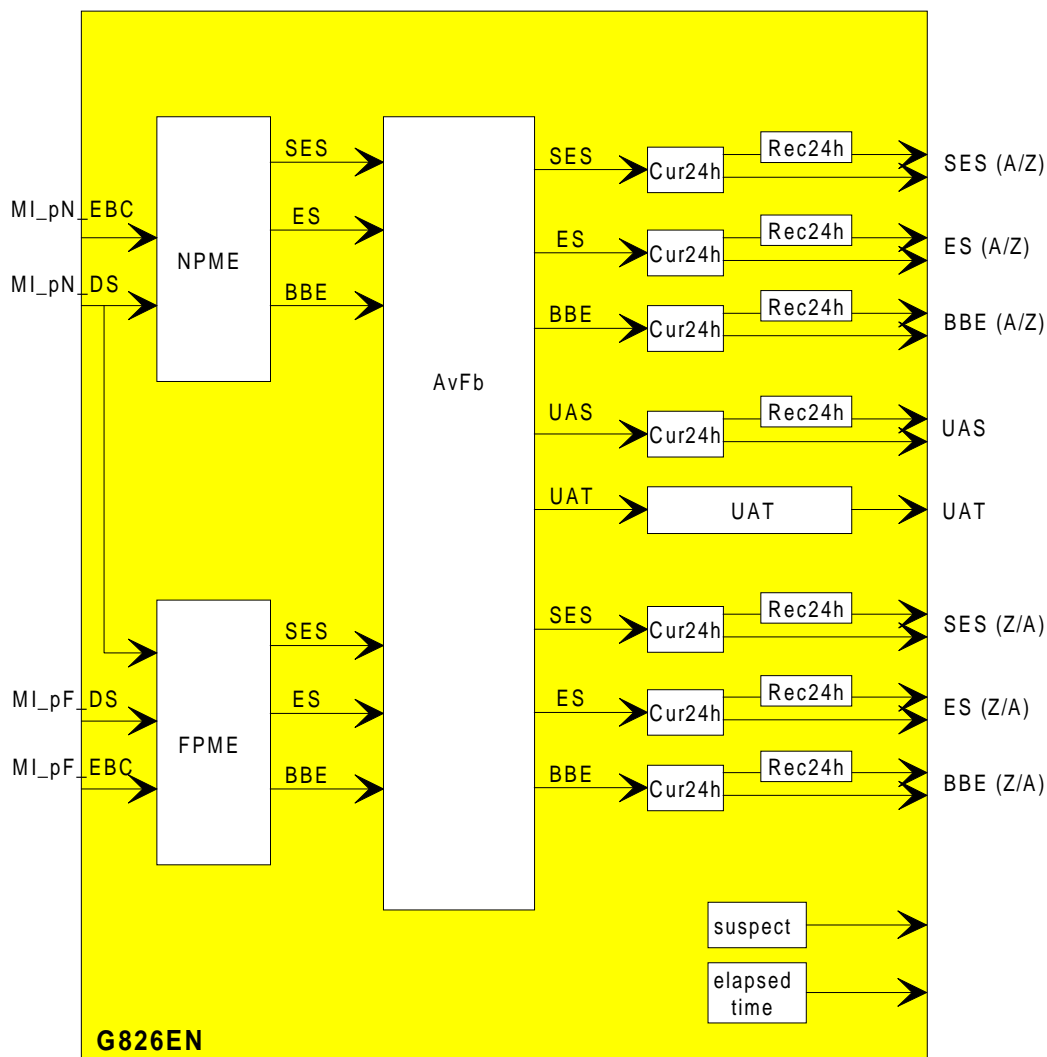

**Figure 25: G.826 performance monitoring at trail termination**

The G.826 bi-directional package at trail end node (G826EN) (figure 25) shall compute UAS, ES, SES, and BBE over periods of 24 hour for both directions of transmission using near-end and far-end information (A/Z & Z/A).

The package can be used at trail termination points to monitor the error performance of the bi-directional trail for services purposes.

During a period of bi-directional unavailable time the counting of BBES, ESs, and SESs shall be stopped.

UAT events shall be computed and logged.

**NOTE:** Thresholding is not applicable for bi-directional error performance monitoring.

#### 4.4.5.4 ITU-T Recommendation G.826 error performance (bi-directional) package at intermediate node along the trail

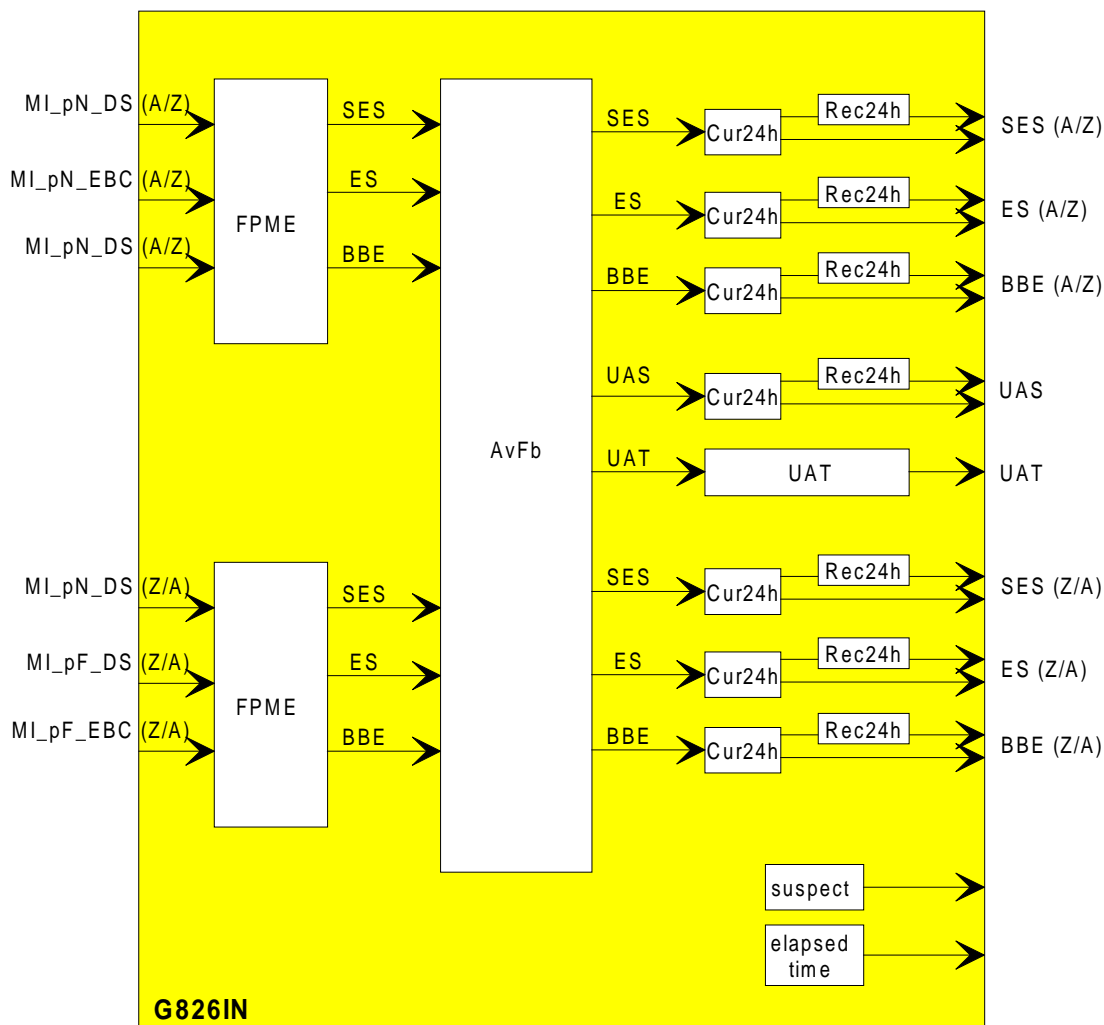

**Figure 26: G.826 performance monitoring at intermediate node**

The G.826 bi-directional package at intermediate node (G826IN) (figure 26) shall compute UAS, ES, SES, and BBE over periods of 24 hour for both directions of transmission using twice the far-end information (from A/Z & Z/A directions) from two non-intrusive monitors.

The package can be used at intermediate connection points to monitor the error performance of the bi-directional trail for services purposes.

During a period of bi-directional unavailable time the counting of BBes, ESs, and SESs shall be stopped.

UAT events shall be computed and logged.

**NOTE:** Thresholding is not applicable for bi-directional error performance monitoring.

#### 4.4.5.5 Pointer Justification Event package

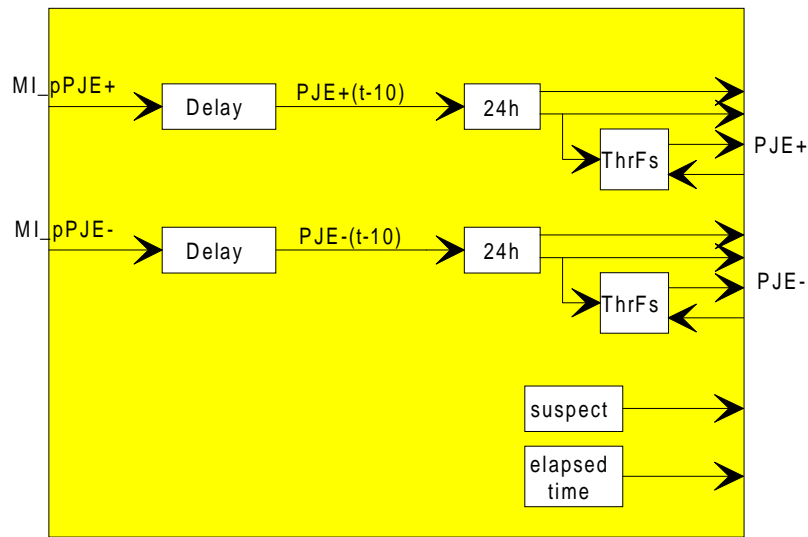
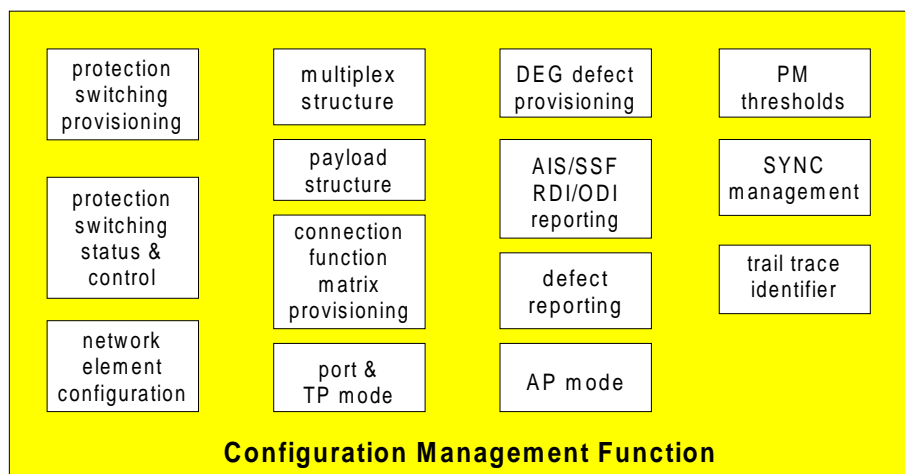

**Figure 27: PJE performance monitoring**

The Pointer Justification Event package shall compute PJE+ and PJE- over periods of 24 hour.

Performance event (PJE+, PJE-) counts shall be monitored for a 24 hour single level threshold crossing.

### 4.5 Configuration Management Functions



**Figure 28: CMF process block diagram**

The CMF provides functionality for managing the configuration of the following functions, processes and parameters in equipment:

- network element configuration;
- protection switching provisioning, status and control;
- trail trace identifiers;
- payload structures;
- matrix provisioning;
- degraded defect;

- port and termination point modes;
- AIS/SSF/RDI/ODI reporting;
- synchronization;
- CRC4 interworking mode;
- performance monitoring;
- alarm configuration;
- multiplex structure;
- access point mode.

### 4.5.1 Network element configuration

A network element may offer many functions, which may be mutually inclusive or exclusive. The equipment configuration commands assemble these functions to give the required network element functionality.

Examples are: equipment inventory provisioning, slot provisioning, port provisioning, trail protection creation/removal.

### 4.5.2 Protection switching provisioning

Network elements may support one or more types of protection schemes (linear MSP, MS SPring, SNCP, VC trail protection). Each scheme can be characterized by the set (or a subset) of the following parameters:

- protection architecture (1+1, 1:n);
- switching type (uni-directional, bi-directional);
- operation type (non-revertive, revertive).

The protection switching scheme of a network element can be set-up autonomously by the network element itself according to its make-up and mode of operation, or it may be done by means of external provisioning.

#### 4.5.2.1 Linear STM-N MS protection

The functions which allow the user to provision the configuration of the protection scheme are:

- establishment of protection, indicating the protection switching mode (uni-/bi-directional) operation mode (revertive/non revertive), extra traffic (supported, not supported), the entities participating in the protection, their role (working/protection), and possibly their priority;
- modification of protection, adding or removing entities and/or modifying their protection characteristics;
- removal of protection;
- wait-to-restore time;
- SF and SD priority.

This information is conveyed between the EMF and an AF via the MI\_SWtype, MI\_OPERtype, MI\_WTRtime, MI\_SFpriority, MI\_SDpriority and MI\_EXTRAttraffic.

**Table 21: Linear MSP related provisioning**

MI signal	Value range	Default value
switching type (MI_SWtype)	uni-directional, bi-directional	No default
operation type (MI_OPERtype)	revertive, non-revertive	No default
extra traffic (MI_EXTRAttraffic)	true, false	No default
wait to restore time (MI_WTRtime)	0, 1,..., 12 minutes	5 minutes
priority of SF and SD conditions in 1:n MSP (MI_SFpriority, MI_SDpriority)	high, low	high

#### 4.5.2.2 STM-N MS SPring protection

For further study.

**Table 22: Multiplex Section shared protection ring related provisioning**

MI signal	Value Range	Default value
for further study		

#### 4.5.2.3 Linear 1+1 SNC protection

The functions which allow the user to provision the configuration of the protection scheme are:

- establishment of protection, indicating the operation mode (revertive/non revertive), SNC protection type (SNC/I, SNC/N, SNC/S), the entities participating in the protection, their role (working/protection);
- modification of protection, adding or removing entities and/or modifying their protection characteristics;
- removal of protection;
- wait-to-restore time, hold off time.

This information is conveyed between the EMF and an AF via the MI\_OPERtype, MI\_WTRtime, MI\_HOtime, MI\_PROTtype.

**Table 23: Linear SNCP related provisioning**

MI signal	Value range	Default value
operation type (MI_OPERtype)	revertive, non-revertive	non-revertive
protection type (MI_PROTtype)	SNC/I, SNC/N	No default
wait to restore time (MI_WTRtime)	0, 1,..., 12 minutes	5 minutes
hold off time (MI_HOtime)	0, 100 ms, 200ms,..., 10s	0

#### 4.5.2.4 Linear 1+1 VC Trail protection

The functions which allow the user to provision the configuration of the protection scheme are:

- establishment of protection, indicating the protection operation mode (revertive/non revertive), the entities participating in the protection, their role (working/protection);
- modification of protection, adding or removing entities and/or modifying their protection characteristics;
- removal of protection;
- wait-to-restore time, hold off time.

This information is conveyed between the EMF and an AF via the MI\_OPERtype, MI\_WTRtime, MI\_HOtime.

**Table 24: Protection related provisioning**

MI signal	Value range	Default value
operation type (MI_OPERtype)	revertive, non-revertive	non-revertive
wait to restore time (MI_WTRtime)	0, 1,..., 12 minutes	5 minutes
hold off time (MI_HOtime)	0, 100 ms, 200ms,..., 10s	0

### 4.5.3 Protection switching status and control

The general facility of protection switching is defined as the substitution of a standby or back-up facility for a designated facility. The functions which allow the user to control the traffic on the protection line are:

- operate/release manual protection switching;
- operate/release force protection switching;
- operate/release lockout.

#### 4.5.3.1 Linear STM-N MS protection

This information is conveyed between the EMF and an AF via the MI\_EXTCMD signal.

**Table 25: Protection related control provisioning**

MI signal	Value range	Default value
external command (MI_EXTCMD)	CLR, LO, FSw, MSw, EXER, LON, CirLON	None

A protection switch event is reported. The information is conveyed from the AF to the EMF via the MI\_PSE signal.

**Table 26: Protection related reporting**

MI signal	Value range	Default value
protection switch event (MI_PSE)	N/A	N/A

#### 4.5.3.2 STM-N MS SPring protection

This information is conveyed between the EMF and an AF via the MI\_EXTCMD signal.

**Table 27: Protection related control provisioning**

MI signal	Value range	Default value
external command (MI_EXTCMD)	CLR, LP-S, FS-R, FS-S, MS-R, MS-S, EXER-R, EXER-S, LOW-R, LOW-S, LP-A	None

A protection switch event is reported. The information is conveyed from the AF to the EMF via the MI\_PSE signal.

**Table 28: Protection related reporting**

MI signal	Value range	Default value
protection switch event (MI_PSE)	N/A	N/A

#### 4.5.3.3 Linear 1+1 SNC protection

This information is conveyed between the EMF and an AF via the MI\_EXTCMD signal.



**Table 29: Protection related control provisioning**

MI signal	Value range	Default value
external command (MI_EXTCMD)	CLR, LO, FSw, MSw, EXER	None

A protection switch event is reported. The information is conveyed from the AF to the EMF via the MI\_PSE signal.

**Table 30: Protection related reporting**

MI signal	Value range	Default value
protection switch event (MI_PSE)	N/A	N/A

#### 4.5.3.4 Linear 1+1 VC Trail protection

This information is conveyed between the EMF and an AF via the MI\_EXTCMD signal.

**Table 31: Protection related control provisioning**

MI signal	Value range	Default value
external command (MI_EXTCMD)	CLR, LO, FSw, MSw, EXER	None

A protection switch event is reported. The information is conveyed from the AF to the EMF via the MI\_PSE signal.

**Table 32: Protection related reporting**

MI signal	Value range	Default value
protection switch event (MI_PSE)	N/A	N/A

#### 4.5.4 Trace identifier processes provisioning and reporting

The following allows the user to provision the operation of a trace identifier process:

- provisioning of source API;
- provisioning of the expected API;
- provisioning of the expected TTI mode;
- enable/disable detection of dTIM.

The source API, expected API and expected TTI mode are communicated from the EMF to an AF via the MI\_TxTI, MI\_ExTI and MI\_ExTI mode signals. The detection mode for dTIM is communicated from the EMF to an AF via the MI\_TIMdis signal.

An AF will report on request of the EMF the value of the received and accepted TTI via the MI\_AcTI signal.

The interface between the EMF and the network management system is defined in DEN/TM-2210-3 [5].

**Table 33: Trace Identifier related provisioning and reporting**

MI signal	Value range	Default value
MI_TxTI	according to ETS 300 147 [1]	N/A
MI_ExTI	according to ETS 300 147 [1], or a fixed repeating single byte (from equipment not supporting trace identifier insertion)	N/A
MI_ExTI mode	mode 1, mode 2	mode 1
MI_TIMdis	false, true	note
MI_AcTI	according to ETS 300 147 [1], or a fixed repeating single byte (from equipment not supporting trace identifier insertion)	N/A
NOTE: There are various network scenarios which require different default settings.		

### 4.5.5 Payload structures provisioning and reporting

An Access Point with multiple adaptation functions connected to it, allows different client signals to be transported via the server signal. This requires a selection of the active client, which is controlled via the activation/deactivation of adaptation functions via the MI\_Active signals.

For cases where an access point has a single adaptation function connected and supports a single client signal only, the MI\_Active signal is fixed (i.e. non provisionable).

An AF will report on request the value of the accepted payload type signal via the MI\_AcSL signal.

**Table 34: Payload type provisioning and reporting**

MI signal	Value range	Default value
MI_Active	true, false	false
MI_AcSL	application dependent	N/A

### 4.5.6 Multiplex structures provisioning and reporting

Adapted Information (AI) may consist of a multiplexed set of adapted client signals. Examples are the AUG multiplex structure within the MSn\_AI and the TUG multiplex structure within the S4\_AI, P31s\_AI and P4s\_AI. Refer to clause 3 of EN 300 417-1-1 [2].

For the case Adapted Information contains a multiplex structure, this multiplex structure shall be defined completely.

The active multiplex structure is the result of the required set of link connection types and numbers that is to be supported by the underlying trail. As such, the multiplex structure at the two ends of a trail has to be the same. The network manager determines this. In general, equipment at one end of the trail is therefore not authorized to determine/modify the multiplex structure autonomously. There are exceptions to this principle.

#### 4.5.6.1 AUG provisioning

The AUG multiplex structure contains at least one AUG1, and may contain one or more AUG4s, AUG16s, AUG64s. Each of the AUGn types within the AUG multiplex structure shall be defined up to the AU level.

The AUG multiplex structure at a MSn\_AP can be a fixed structure defined by the equipment; e.g. 16x AU-4 within the AUG16. Otherwise, the AUG multiplex structure is flexible and it shall be provisioned up to the AU level by the network manager. For the case equipment default to one of the options, care should be taken by the network manager that such will result in the required set of link connection types and numbers; otherwise the default multiplex structure configuration shall be overwritten by the required one.

When an equipment supports a subset of the AU types (e.g. AU4 and AU-4-16c), a AUG16 provisioning can select between 1xAU-4-16c or 16xAU-4. No intermediate AUG4 step is present.

When an equipment supports AU-4, AU-4-4c and AU-4-16c, an AUG16 provisioning may require multiple steps in provisioning:

- for the AUG16 select between 1xAU-4-16c and 4xAUG4;
- then select for each (of the four) AUG4s between 1xAU-4-4c and 4xAU-4.

#### 4.5.6.2 AUG autonomous adaptation

There is one exception at AU level with respect to the AUG provisioning rule. The protection bandwidth's (not the working) AUG multiplex structure within the "pass through nodes" in an MS SPring ring is autonomously adapted to the incoming protection bandwidth's AUG multiplex structure, to support protection switching times of 50 ms in mixed AU type rings. In "switching nodes" in the MS SPring ring the AUG multiplex structure within the protection bandwidth is the result of the switching action in the MSP2fsh\_C function. In "extra traffic add/drop nodes" in the MS SPring ring, the AUG multiplex structure within the protection bandwidth is the result of the added/dropped extra traffic. The protection bandwidth within the MS SPring ring behaves as an "AU transparent pipe."

#### 4.5.6.3 AUG reporting

Except for the AU transparent pipe protection bandwidth in the MS SPring ring, there is currently no requirement to report the AUG multiplex structure in the received signal.

To support fault localization, the AUG multiplex structure as received in the incoming signal shall be reported.

#### 4.5.6.4 TUG provisioning

The TUG multiplex structure contains three TUG3s, and may contain one or more TUG2s. Each of the TUGn types within the TUG multiplex structure shall be defined up to the TU level.

The TUG multiplex structure at a S4\_AP, P31s\_AP, P4s\_AP can be a fixed structure defined by the equipment; e.g. 63x TU-12 within the VC4. Otherwise, the TUG multiplex structure is flexible and it shall be provisioned up to the TU level by the network manager. For the case equipment default to one of the options, care should be taken by the network manager that such will result in the required set of link connection types and numbers; otherwise the default multiplex structure configuration shall be overwritten by the required one.

When an equipment supports a subset of the TU types (e.g. TU3 and TU12), a TUG3 provisioning can select between 1xTU3 or 21xTU12. No intermediate TUG2 step is present.

When an equipment supports TU3, TU2, TU12, a TUG provisioning may require multiple steps in provisioning:

- for each (of the three) TUG3 select between 1xTU3 and 7xTUG2;
- then select for each (of the seven) TUG2s between 1xTU2 and 3xTU12.

**Table 35: Multiplex structure provisioning and reporting**

MI signal	Value range	Default value
MI_Active	false, true	N/A

#### 4.5.6.5 TUG reporting

There is currently no requirement to report the TUG multiplex structure in the received signal.

### 4.5.7 Matrix connections provisioning

A connection function is surrounded by Connection Points (CP) and Termination Connection Points (TCP). Each TCP is identified via the API associated with its Trail Termination function, and each CP is identified via the API associated with its Adaptation function, extended with a (if applicable) Tributary Signal Number (TSN).

For the case of a trail protection, the Access Points (AP) are named as follows: AP of working #i and AP of normal #i have the same AP Identifier, AP of protection has a separate AP identifier, AP of extra traffic has the same AP Identifier as the AP of protection. This maintains the CPId's when the interface changes from unprotected to protected and vice versa.

The relation with the information model naming scheme defined in figures A.2 and A.3 of ITU-T Recommendation G.774 [25] is as follows:

- APId, TCPIId are represented by the TTP;
- CPId is represented by the CTP.

A matrix connection is therefore characterized by its (T)CP ID's communicated between EMF and AF via the MI\_ConnectionPortIds signal. The connection type is communicated via MI\_ConnectionType and directionality via MI\_Directionality signals.

**Table 36: Matrix connection related provisioning**

MI signal	Value range	Default value
MI_ConnectionPortIds	set of (T)CP Id's	No default
MI_ConnectionType	unprotected, 1 + 1 protected, ...	No default
MI_Directionality	uni-directional, bi-directional	No default

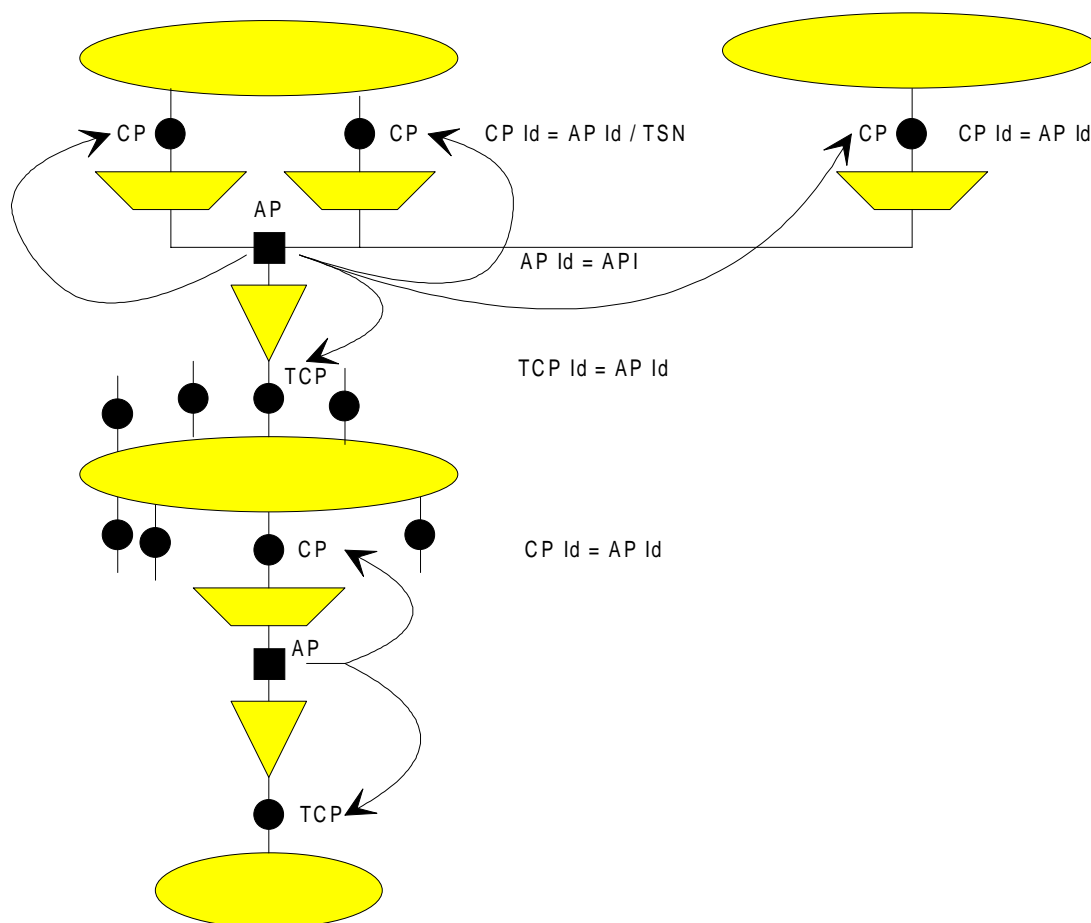

**Figure 29: CP and TCP Identification scheme**

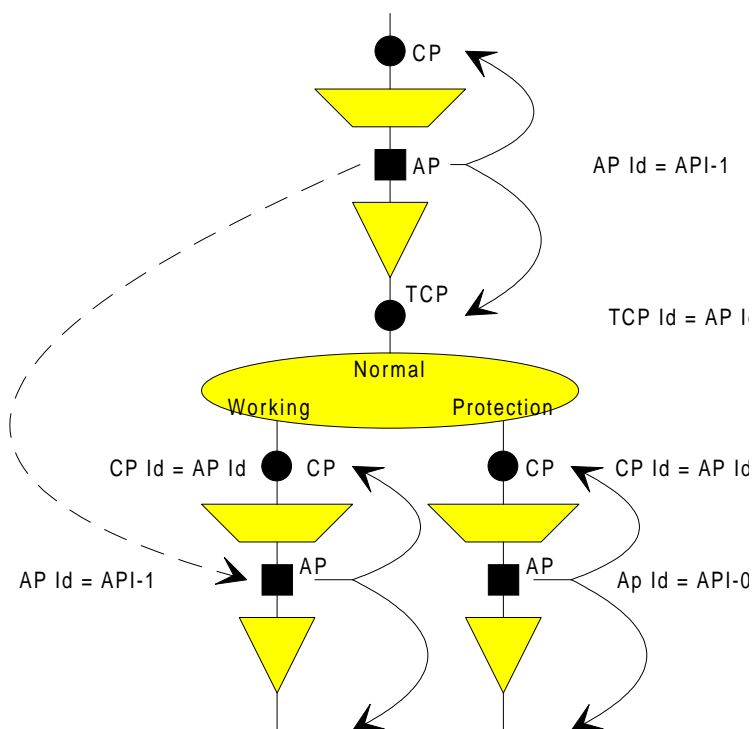

Figure 30: CP and TCP Identification scheme for case of 1+1 trail protection

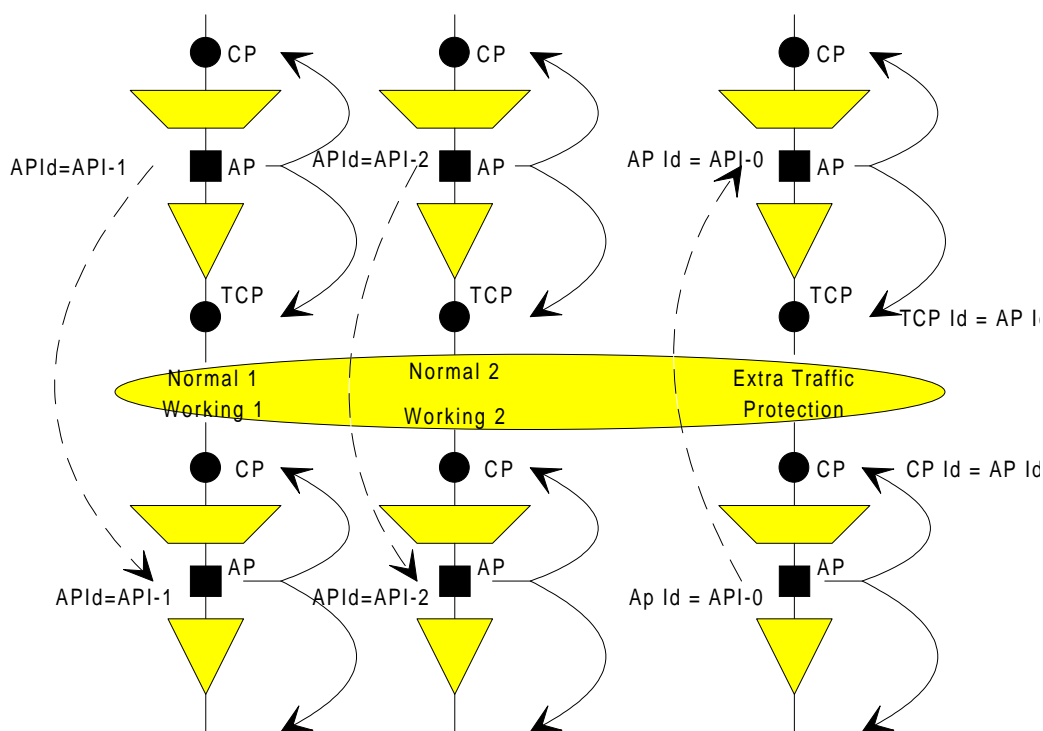

Figure 31: CP and TCP Identification scheme for case of 1:n trail protection

## 4.5.8 DEG thresholds setting

The values for the threshold and monitoring period of the Degraded defect detector process requires setting. These values are communicated between the EMF and an AF via the MI\_DEGTHR, MI\_DEGM signals.

**Table 37: Error defect detection related provisioning**

MI signal	Value range	Default value
Degraded defect interval threshold selection (MI_DEGTHR)	0...N EBs	SES estimator
Degraded defect monitor period selection (MI_DEGM)	2...10	7

Whether this function applies globally or a per instance basis is beyond the scope of the present document. Examples are:

- global per network element;
- global per network layer in the network element;
- global per server/aggregate signal in the network element;
- individual per trail/signal in the network element.

## 4.5.9 Port mode, Termination Point mode provisioning

This function controls the operational mode of trail termination sink functions for fault management.

**Table 38: Port and Termination Point mode related provisioning**

MI signal	Value range	Default value
Port mode control (MI_Portmode)	MON, (AUTO), NMON	AUTO (if supported) otherwise NMON
Termination Point mode control (MI_TPmode)	MON, NMON	NMON

## 4.5.10 Access Point mode provisioning

This function is envisaged to control the operational mode of adaptation sink functions for fault management. It is for further study.

**Table 39: Access Point mode related provisioning**

MI signal	Value range	Default value
For further study		

## 4.5.11 Defect reporting provisioning

This function controls the operational mode of AIS, SSF, RDI and ODI defect reporting for fault management.

**Table 40: Consequential defect/failure provisioning**

MI signal	Value range	Default value
MI_AIS_Reported	true, false	false
MI_SSF_Reported	true, false	false
MI_RDI_Reported	true, false	false
MI_ODI_Reported	true, false	false

Whether this function applies globally or a per instance basis is beyond the scope of the present document. Examples are:

- global per network element;
- global per network layer in the network element;
- global per server/aggregate signal in the network element;
- individual per trail/signal in the network element.

#### 4.5.12 2 Mbit/s multiframe alignment provisioning

This function controls the operational mode of the 2 Mbit/s multiframe alignment process for the case more than one option is supported.

**Table 41: 2 Mbit/s multiframe alignment mode provisioning**

MI signal	Value range	Default value
2 Mbit/s multiframe alignment process mode control (MI_CRC4mode)	ON, OFF, AUTO	AUTO

#### 4.5.13 Network element synchronization provisioning

These functions provide for the control and monitoring of the synchronization subsystem in the network element. Refer to EN 300 417-6-1 [4].

##### 4.5.13.1 Quality Level mode provisioning

This function enables or disables the use of synchronization quality levels as a synchronization reference selection condition for the network element.

**Table 42**

MI signal	Value range	Default value
Quality Level mode (MI_QLmode)	disabled, enabled	enabled

##### 4.5.13.2 Timing Marker mode provisioning

This function controls the message set within a 34 Mbit/s and 140 Mbit/s interface carrying synchronization.

**Table 43**

MI signal	Value range	Default value
Timing Marker mode (MI_TMmode)	enabled (TM), disabled (SSM)	no default

##### 4.5.13.3 SSM and TM support provisioning

This function enables/disables the interpretation of the SSM or TM bits in incoming interface carrying synchronization. For the case MI\_SSMsupp is false, the received SSM bit in the S1 byte should not be interpreted as a valid QL value and the CI\_QL shall be forced to the QL-NSUPP.

**Table 44**

MI signal	Value range	Default value
SSM supported (MI_SSMsupp)	false, true	

#### 4.5.13.4 SSM and TM disabling provisioning

This function suppresses the generation of QL values in the SSM or TM bits on the outgoing interface.

**Table 45**

MI signal	Value range	Default value
MI_SSMdis	disabled, enabled	

#### 4.5.13.5 Qoverwrite and QfixedValue provisioning

These functions allow the forced assignment of a QL value at an incoming interface carrying synchronization.

**Table 46**

MI signal	Value range	Default value
MI_QLoverwrite	False, true	false
MI_QLfixedValue	QL-PRC, QL-SSUT, QL-SSUL, QL-SEC, QL-DNU	no default

#### 4.5.13.6 CSid assignment

There are no external command for Csid assignment. This is carried out autonomously and internally by the NE.

**Process:**

This process assigns a unique Csid to each transport and station clock input port.

#### 4.5.13.7 QLminimum provisioning

This function allows the assignment of a minimum acceptable QL threshold. If the incoming QL value is lower than the assigned minimum the output signal will be squelched or set to AIS as appropriate.

**Table 47**

MI signal	Value range	Default value
MI_QLminimum	QL-PRC, QL-SSUT, QL-SSUL, QL-SEC, QL-DNU	no default

#### 4.5.13.8 NE clock behaviour

These functions determine the behaviour of the NE clock under freerun and holdover conditions and control the characteristics of the holdover memory.

The MI\_CkMode reports the current mode of operation.

**Table 48**

MI signal	Value range	Default value
MI_CkOperation	Forced Freerun, Forced Holdover, Normal	Normal



#### 4.5.13.9 NS Priority configuration

This function determines the priority setting for nominated synchronization sources.

**Table 49**

MI signal	Value range	Default value
MI_priority	1 to n or dis(abled)	No default

#### 4.5.13.10 NS Lockout commands

These functions provide operations and maintenance commands for the lockout of each nominated synchronization source in the synchronization sub-system.

The lockout state of a synchronization source is set or cleared by the appropriate command message.

The current state can be requested by the MI\_State command which will report Norm, Fail or WTR.

**Table 50**

MI signal	Value range	Default value
MI_CLR_WTR	No parameters	
MI_Set_lockout	No parameters	
MI_Clr_Lockout	No parameters	

#### 4.5.13.11 NS External commands

These functions provide operations and maintenance commands for Manual and Forced switching of nominated synchronization sources in the synchronization sub-system.

The manual state is set or cleared by the appropriate command message.

The forced state is set or cleared by the appropriate command message.

If the NE synchronization sub-system rejects these commands, the MI\_Reject\_Request shall be generated by the NE.

The MI\_SelectedInput command may be used to request the identity of the currently selected synchronization source.

**Table 51**

MI signal	Value range	Default value
MI_EXTCMD_ClearManualSwitch	No parameters	
MI_EXTCMD_ClearForcedSwitch	No parameters	
MI_EXTCMD_ManualSwitch	1 to n	No default
MI_EXTCMD_ForcedSwitch	1 to n	No default

#### 4.5.13.12 NS Wait to restore time

This function determines the wait to restore time setting that applies across all NE synchronization sources.

NOTE: There is a discrepancy between this and EN 300 417-6-1 [4]. Also this may not be suitable for SSU type applications. This is for further study.

**Table 52**

MI signal	Value range	Default value
MI_WTR	0 to 12 minutes	5 minutes

#### 4.5.13.13 Select Sa bit for SSM provisioning

This function selects which of the sa bits in a 2Mbit/s time slot zero will be used for SSM messaging.

**Table 53**

MI signal	Value range	Default value
MI_SelSaSSM	sa4 to sa8	No default

#### 4.5.14 Performance Monitoring 15 minute and 24 hour TR and RTR threshold setting

The threshold values for performance events counted over 15 minute and 24 hours require setting. Those values shall be programmable. The range of the thresholds and their default values are layer specific and shall be as specified in tables 54 and 55.

**Table 54: ES, SES and BBE TR and RTR ranges and defaults**

Layer	ES, SES, BBE TR (15m, 24h) and RTR (15m)	
	range	default
RS1	Refer to subclause 5.1.10 of EN 301 167 [5]	Refer to subclause 5.4.6.1 of EN 301 167 [5] subclause 5.4.6.2 of EN 301 167 [5]
RS4		
RS16		
RS64		
MS1	Refer to subclause 5.3.6.1 of EN 301 167 [5] subclause 5.3.6.2 of EN 301 167 [5]	
MS4		
MS16		
MS64		
VC-4-64c	for further study	for further study
VC-4-16c		
VC-4-4c	Refer to subclause 5.1.10 of EN 301 167 [5]	Refer to subclause 5.2.6.1 of EN 301 167 [5] subclause 5.2.6.2 of EN 301 167 [5]
VC-4		
VC-3		
VC-2		
VC-12		
VC-11		
P4s	TBD	for further study
P31s	TBD	
P4e	TBD	M.2100 (note)
P31e	TBD	
P22e	TBD	
P12s	TBD	M.2100
NOTE: BBE is not defined for P4e, P31e, P22e.		

Table 55: PJE TR ranges and defaults

Signal	PJE TR (24h)	
	range	default
AU-4-64c	TBD	5 (PJE)
AU-4-16c	TBD	5 (PJE)
AU-4-4c	TBD	5 (PJE)
AU-4	TBD	5 (PJE)
TU-3	-	-
TU-2	-	-
TU-12	-	-
TU-11	-	-

## 5 DCC Layer Functions

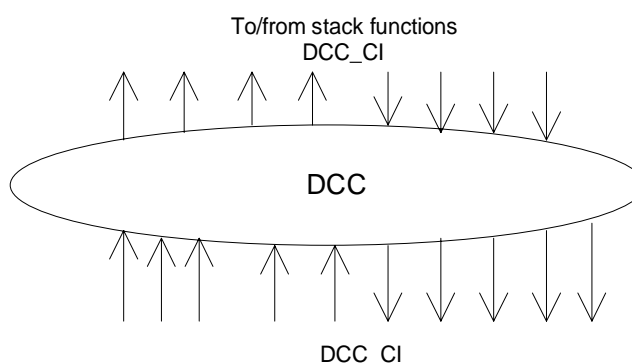

Figure 32: DCC layer atomic functions

### DCC layer CP

The CI at this point is bit structured signal which can have a bandwidth of either 64 kbit/s in the case of an P4s or P31s DCC, 192 kbit/s in the case of a RSn DCC or 576kbit/s in case of a MSn DCC. The timing is contra-directional with the DCC Trail Termination as "subordinate" function and the DCC server layer as controlling. The DCC\_CI uses the LAPD format specified in ITU-T Recommendation Q.921 [10] or is as an undefined signal.

### DCC Layer AP

The AI of the DCC is outside the scope of the present document.

### LAPD signal and the order of its transmission

The LAPD signal is a serial bit stream containing stuffed LAPD frames surrounded by one or more flag sequences. The LAPD format is defined in ITU-T Recommendation Q.921 [10]. A LAPD frame consists of N octets as presented in figure 33. The LAPD frame is transmitted right to left and top to bottom. A 0 bit is inserted after all sequences of five consecutive 1 bits within the LAPD frame content (octets 2 to N-1) ensuring that a flag or abort sequence is not simulated within a frame.

The stuffed LAPD frame does not necessarily contain an integer number of octets as a consequence of the 0 insertion process. Therefore there is no direct mapping of a stuffed LAPD frame into bytes within a DCC channel in e.g. an STM-N signal. The LAPD signal is a serial bit stream and will be inserted into the DCC channel such that the bits will be transmitted on the STM-N in the same order that they were received from the LAPD signal generator.

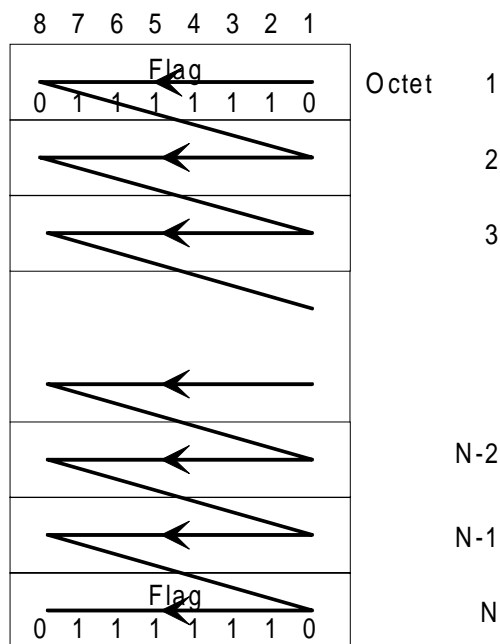

The order of transmission is from right to left and top to bottom

Figure 33: Q.921 (LAPD) frame format and order of transmission

## 5.1 DCC connection function DCC\_C

Symbol:

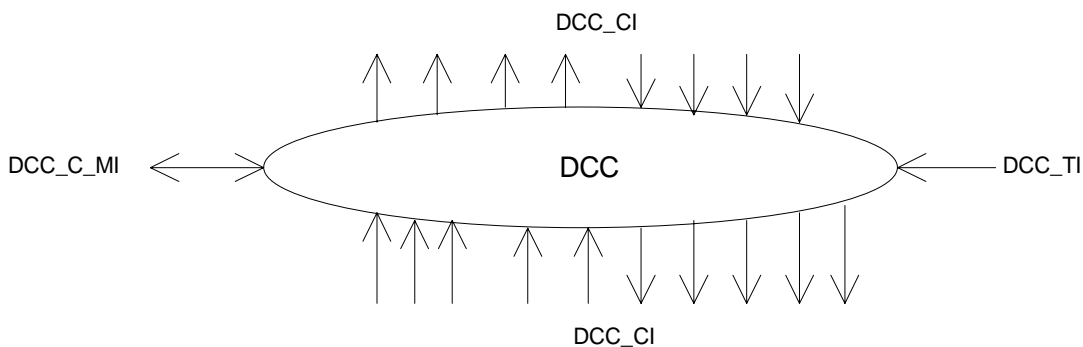

Figure 34: DCC\_C symbol

Interfaces:

Table 56: DCC\_C input and output signals

Input(s)	Output(s)
per DCC_CI, n x for the function: DCC_CI_CK_So DCC_CI_D_Sk DCC_CI_CK_Sk DCC_CI_SSF_Sk	per DCC_CI, n x per function: DCC_CI_D_So
per input and output connection point: DCC_C_MI_ConnectionPortIds	

**Processes:**

In the DCC\_C function DCC Layer Characteristic Information is routed between input (termination) connection points ((T)CPs) and output (T)CPs by means of matrix connections.

NOTE 1: Neither the number of input/output signals to the connection function, nor the connectivity is specified in the present document. That is a property of individual network elements.

NOTE 2: The DCC connection function is a multi-rate and timing-transparent matrix. The connection function can not set connections between CPs. Such connections shall be via TCP through higher layers.

NOTE 3: TCPs of DCC Trail Termination functions may be rate adaptive and may be connected to arbitrary CPs.

Figure 32 present a subset of the atomic functions that can be connected to this DCC connection function: DCC trail termination functions and adaptation functions in the P4s, P31s (synchronous 140 and 34 Mbit/s paths), RSn and MSn server (i.e. STM-N regenerator/multiplex section) layers will be connected to this DCC connection function.

*Routing:* the function shall be able to connect a specific input with a specific output, provided they have the same bandwidth, by means of establishing a matrix connection between the specified input and output. It shall be able to remove an established matrix connection.

Each (matrix) connection in the DCC\_C is unprotected, bi-directional and shall be characterized by the:

Nominal bandwidth of connection	64 kbit/s, 192 kbit/s, 576 kbit/s;
Input and output connection points	set of connection point identifiers (refer to EN 300 417-1-1 [2], subclause 3.3.6).

*Unequipped DCC generation:* An unequipped DCC signal is undefined.

**Defects:** None.

**Consequent Actions:**

If an output of this function is not connected to one of its inputs, the function shall connect an unequipped DCC signal to the output.

**Defect Correlation:** None.

**Performance Monitoring:** None.

---

## 6 V11 Section Layer Functions

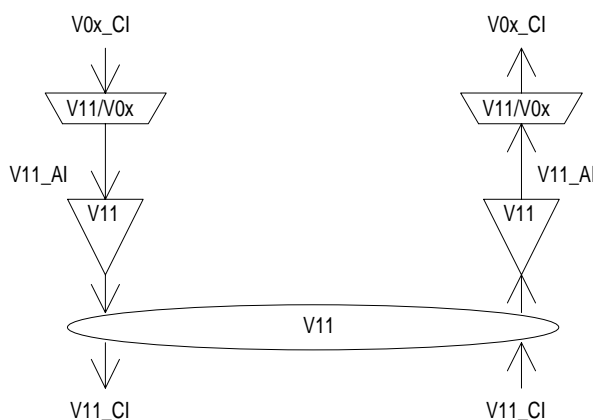

**Figure 35: V11 Section atomic functions**

**V11 layer CP.**

The Characteristic Information V11\_CI of the intra-station electrical layer CP is a digital, electrical signal of defined amplitude, bit rate and pulse shape specified in ITU-T Recommendation V.11 [11].

**V11 layer AP.**

The information passing across the V11/V0X AP is a X kbit/s signal with contra-directional bit and byte timing signal. X can be a value in the range up to 10 Mbit/s. In SDH equipment, the V11 payload is typically any of the (64 kbit/s) user channel signals or national use signals.

**6.1 V11 Connection function V11\_C**

Not applicable.

**6.2 V11 Trail Termination functions****6.2.1 V11 Trail Termination Source V11\_TT\_So**

**Symbol:**

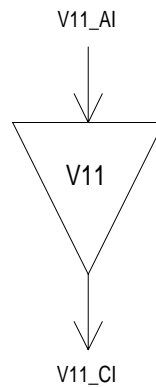

**Figure 36: V11\_TT\_So symbol**

**Interfaces:**

**Table 57: V11\_TT\_So input and output signals**

Input(s)	Output(s)
V11_AI_D V11_AI_CK	V11_CI_D V11_CI_CK

**Processes:**

This function generates the electrical signal used for transmission of information stream across an User interface specified in ITU-T Recommendation V.11 [11] accompanied by associated timing element signals.

**Defects:** None.

**Consequent Actions:** None.

**Defect Correlations:** None.

**Performance Monitoring:** None.

## 6.2.2 V11 Trail Termination Sink V11\_TT\_Sk

Symbol:

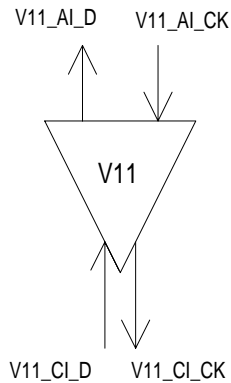

Figure 37: V11\_TT\_Sk symbol

Interfaces:

Table 58: V11\_TT\_Sk input and output signals

Input(s)	Output(s)
V11_CI_D V11_AI_CK	V11_AI_D V11_CI_CK

**Processes:** None.

This function accepts the electrical signal used for transmission of information stream across an user interface specified in ITU-T Recommendation V.11 [11].

**Defects:** None.

**Consequent Actions:** None.

**Defect Correlations:** None.

**Performance Monitoring:** None.

## 6.3 V11 Adaptation functions

### 6.3.1 V11 to V0X Adaptation Source V11/V0X\_A\_So

Symbol:

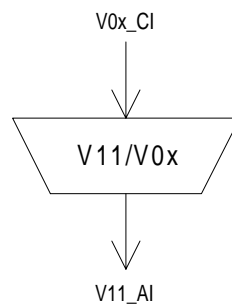

Figure 38: V11/V0X\_A\_So symbol

**Interfaces:****Table 59: V11/V0X\_A\_So input and output signals**

Input(s)	Output(s)
V0X_CI_D V0X_CI_CK	V11_AI_D V11_AI_CK

**Processes:** None.

This function passes through the data and clock signals for transmission on an electrical media from the 64 kbit/s user data from one of the user channel bytes specified in ITU-T Recommendation V.11 [11].

**Defects:** None.

**Consequent Actions:** None.

**Defect Correlations:** None.

**Performance Monitoring:** None.

### 6.3.2 V11 to V0X Adaptation Sink V11/V0X\_A\_Sk

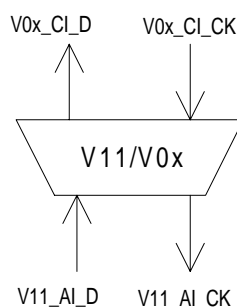
**Symbol:****Figure 39: V11/V0X\_A\_Sk symbol****Interfaces:****Table 60: V11/V0X\_A\_Sk input and output signals**

Input(s)	Output(s)
V11_AI_D V0X_CI_CK	V0X_CI_D V11_AI_CK

**Processes:**

This function passes through the data and clock signals.

**Defects:** None.

**Consequent Actions:** None.

**Defect Correlations:** None.

**Performance Monitoring:** None.



---

## 7 Power Feed Functions

For further study.

## Annex A (informative): Applications/Topologies of Performance Monitoring

Performance monitoring refers to a set of applications and topologies using different combinations of the performance monitoring functions. Performance monitoring can be uni- and bi-directional, single and dual ended, at trail terminating network elements or intermediate network elements along the trail.

The following figures define architectures for layer trails and sublayer trails using the M.2100/2101 and G.826 performance monitoring packages as examples.

### A.1 Single-ended, bi-directional performance monitoring architecture at a termination node

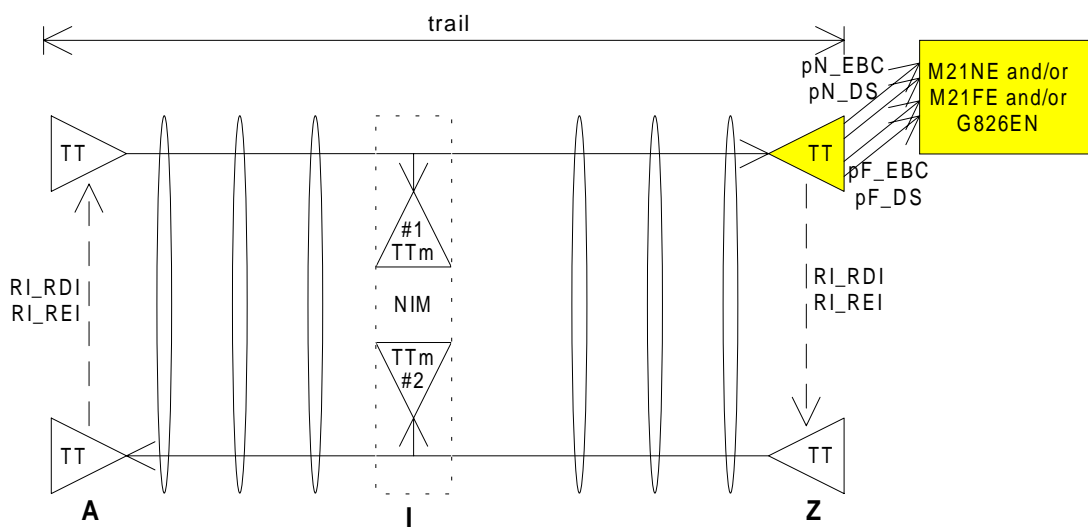

**Figure A.1: Performance monitoring architecture option at trail terminating node (maintenance and services based)**

## A.2 Single-ended, bi-directional performance monitoring architecture at an intermediate node

Performance monitoring at an intermediate node within a trail will use far-end maintenance information for both directions of the trail. Near-end information presents the performance of the trail segment up to the monitoring point only.

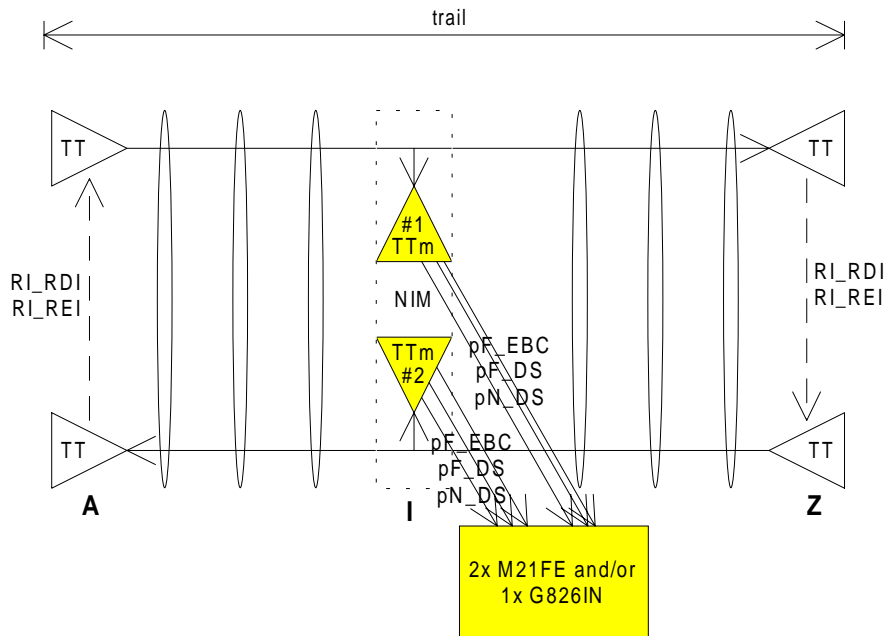

**Figure A.2: Performance monitoring architecture option at intermediate node (maintenance and services based)**

## A.3 Dual ended, bi-directional performance monitoring architecture at termination nodes

Performance monitoring at both terminating nodes of a trail will use near-end maintenance information for both directions of the trail.

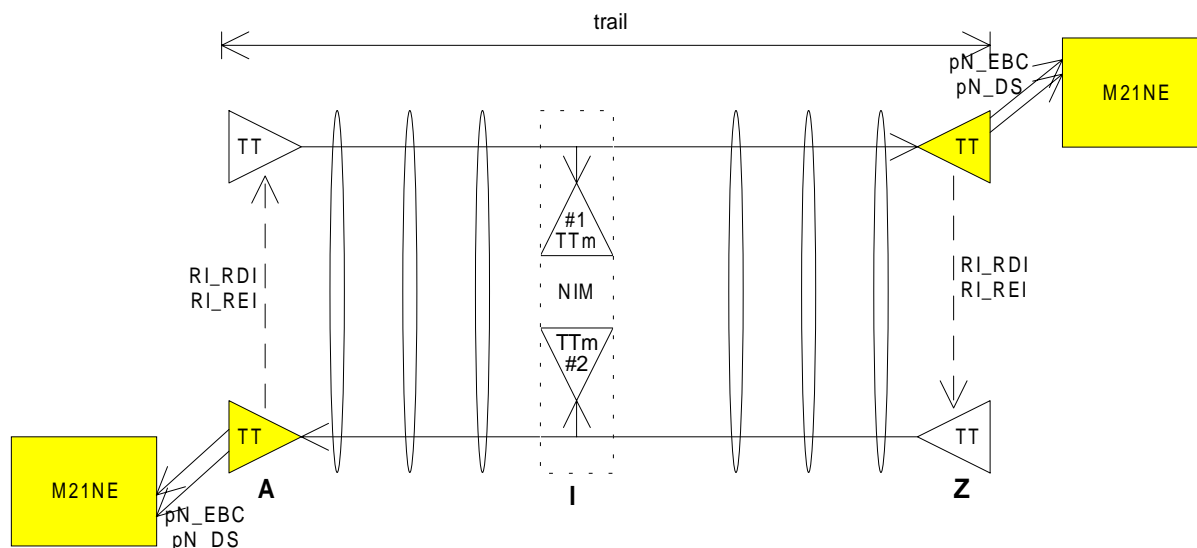

Figure A.3: Performance monitoring architecture option at terminating nodes (maintenance based only)

## A.4 Performance monitoring architecture at an intermediate node for fault localization

Performance monitoring at an intermediate node of a trail for fault localization will use near-end maintenance information.

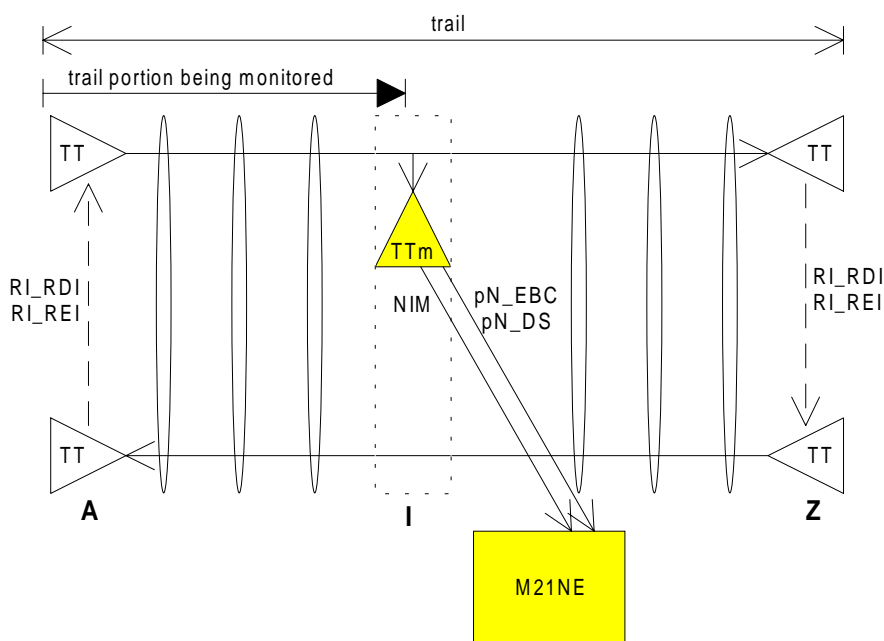
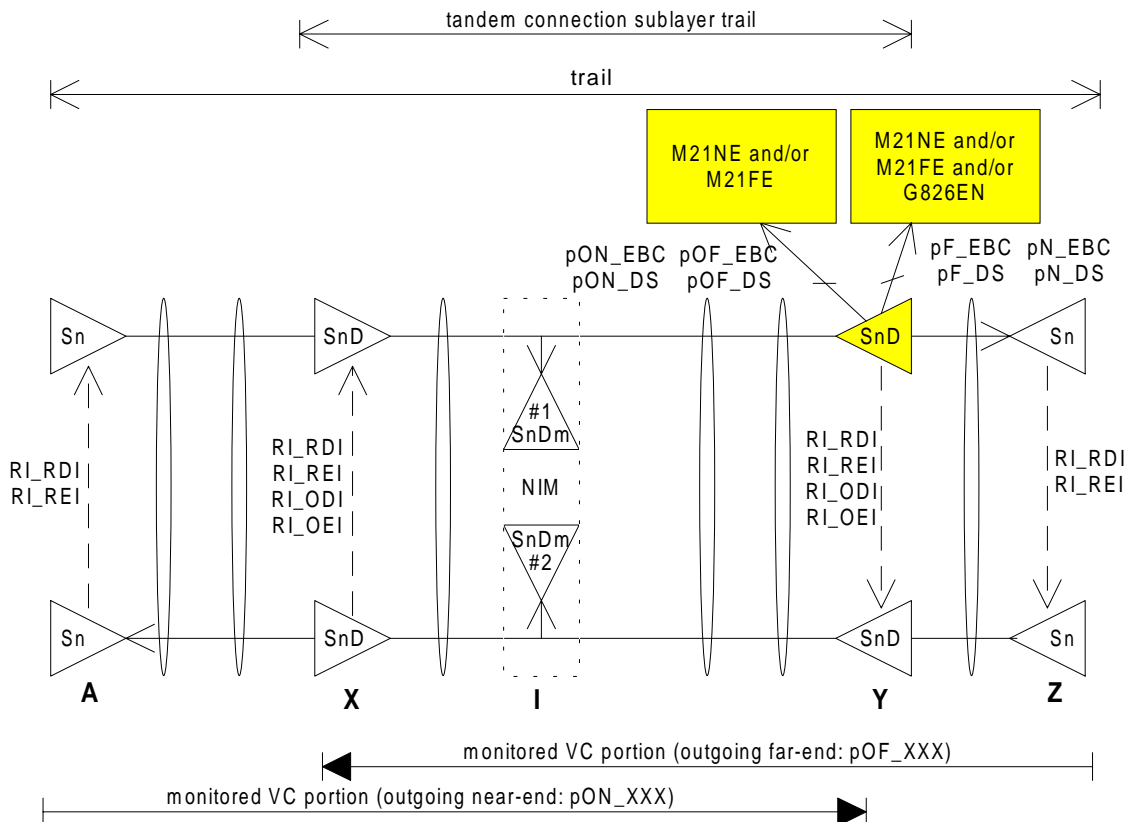

Figure A.4: Performance monitoring architecture option at intermediate node for fault localization

## A.5 Single ended, bi-directional TCM related performance monitoring architecture at a TC termination node



**Figure A.5: Performance monitoring architecture option at tandem connection terminating node for TC and outgoing VC (TC: maintenance and error performance based, VC: maintenance based)**

## A.6 Single ended, bi-directional TCM related performance monitoring architecture at an intermediate node

Performance monitoring at an intermediate node within a tandem connection trail will use far-end maintenance information for both directions of the tandem connection trail. Near-end information presents the performance of the tandem connection trail segment up to the monitoring point only.

**NOTE:** Performance monitoring of outgoing information of the two directions at an intermediate node present the quality of two partly overlapping VC-n trail portions (A/Y and Z/X).

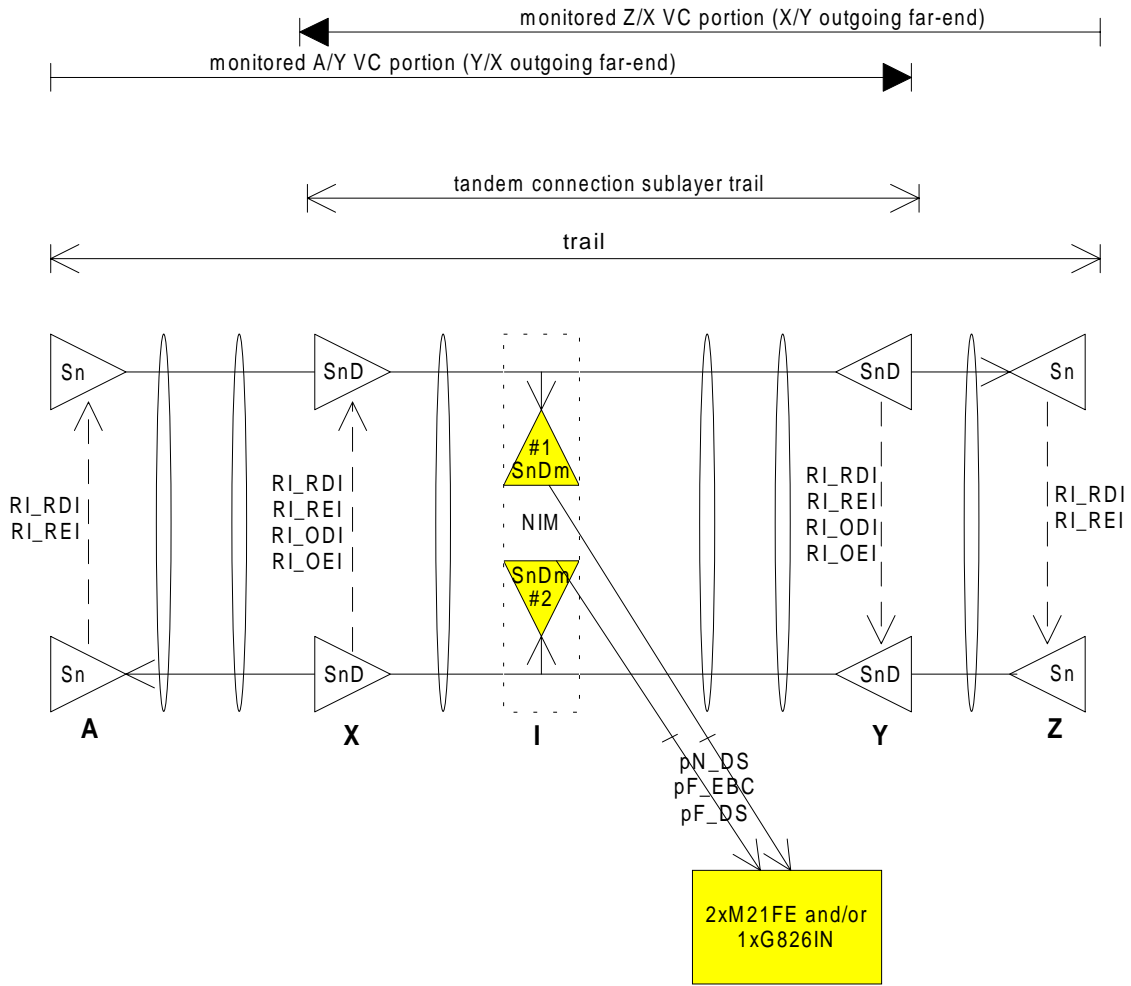

Figure A.6: Performance monitoring architecture option at tandem connection intermediate node for TC (TC: maintenance and error performance based)

## Annex B (informative): Examples of some performance monitoring packages

Figure B.1 illustrates a modified lower complexity M21NE performance monitoring package; to save memory in equipment, this package does not specify the use of recent registers. Current registers (15 minute and 24 hour) are defined together with single level thresholding. For the case one of the thresholds is reached or crossed, this package could be extended with recent registers for further error/fault analysis.

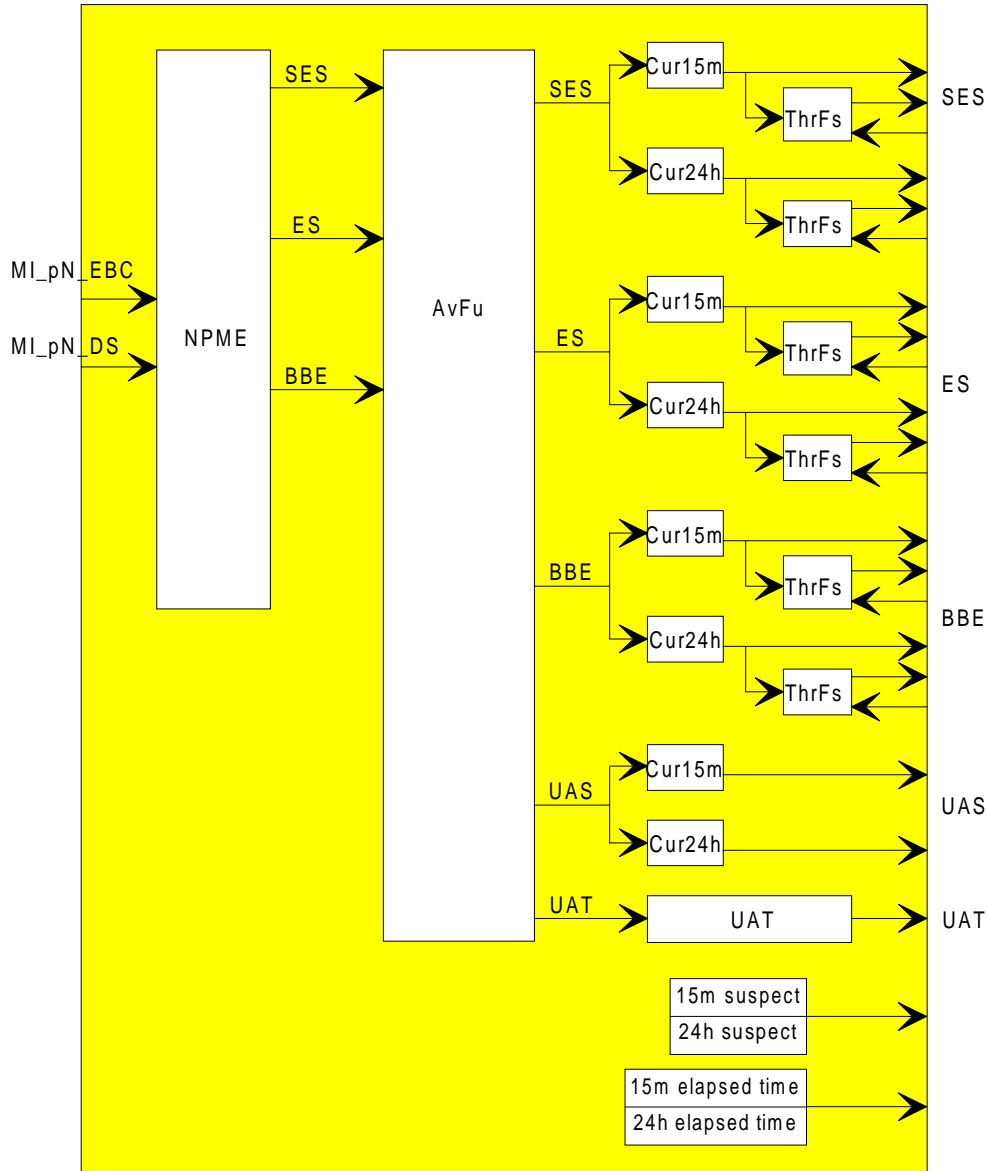

Figure B.1: M21NE without recent registers

Figure B.2 illustrates an extended M21NE package. For this case, the CSES function is added.

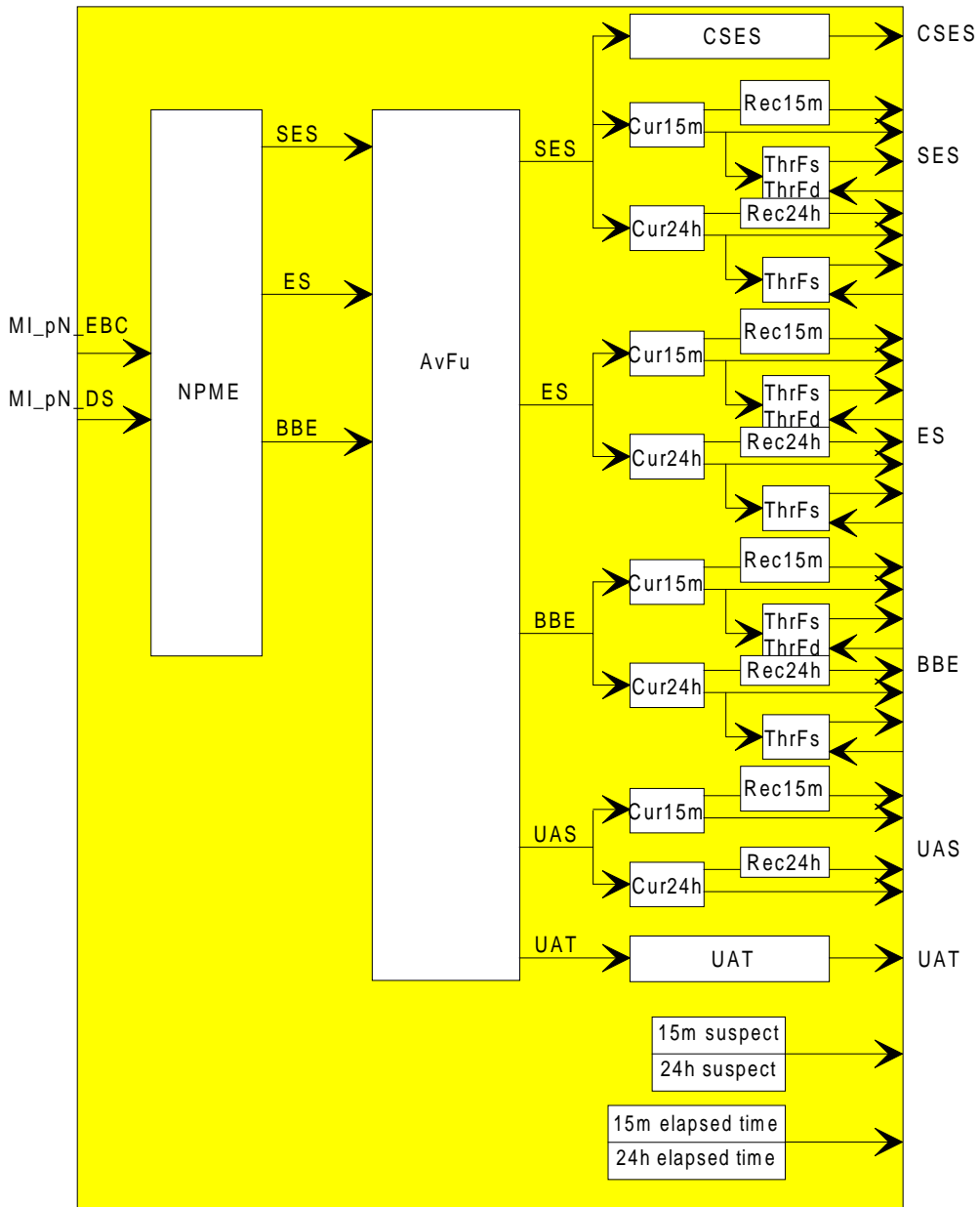

Figure B.2: M21NE extended with CSES monitoring



---

## Annex C (informative): Use of NPME/FPME functions when both G.826 and M.2100/M.2101.1 packages are selected for one termination point

Except for 2 Mbit/s termination points, a combined M21NE, M21FE and G826EN performance monitoring package may share the NPME and FPME functions as indicated in figure C.1. For the case of 2 Mbit/s (P12s) termination points, separate NPME/FPME functions (see figure C.2) are needed while the SESestimators for the uni-directional (M.2100 based) and bi-directional (G.826 based) performance monitoring are different.

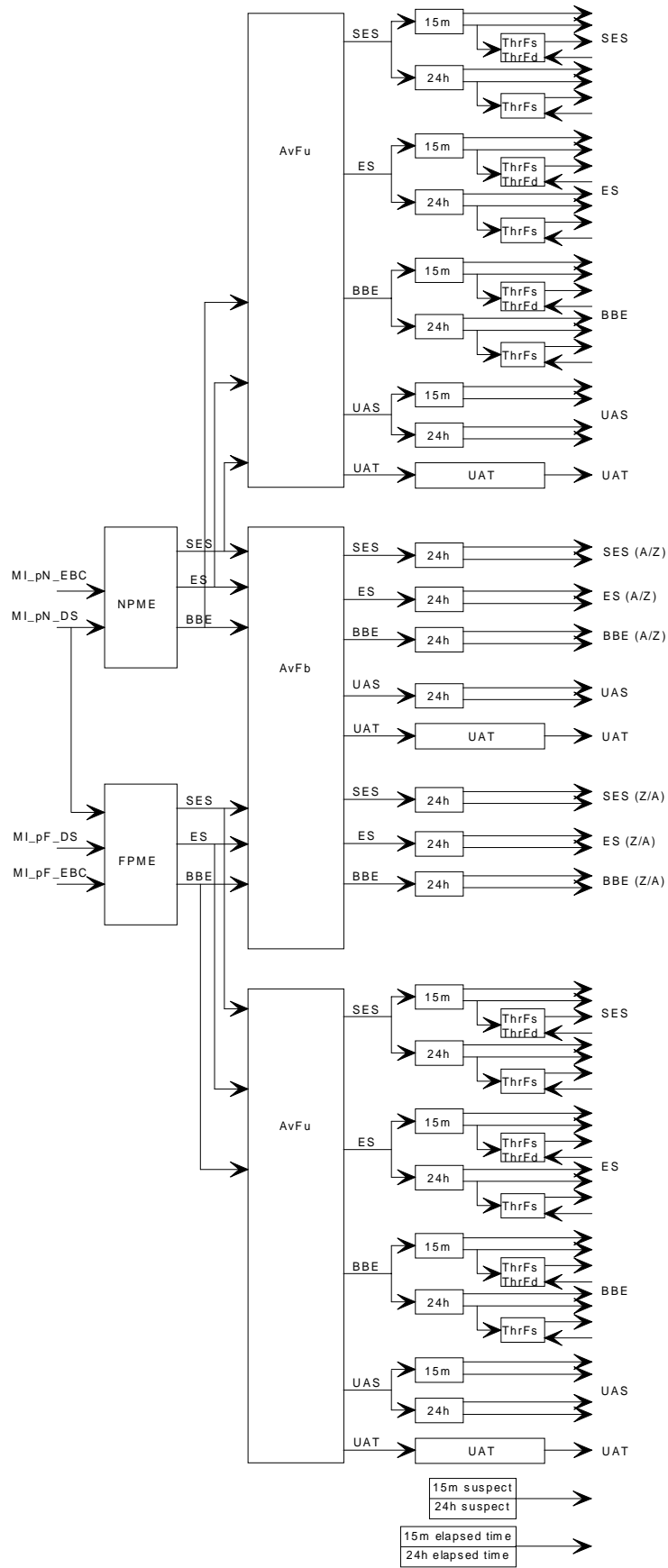

Figure C.1: Sharing NPME and FPME

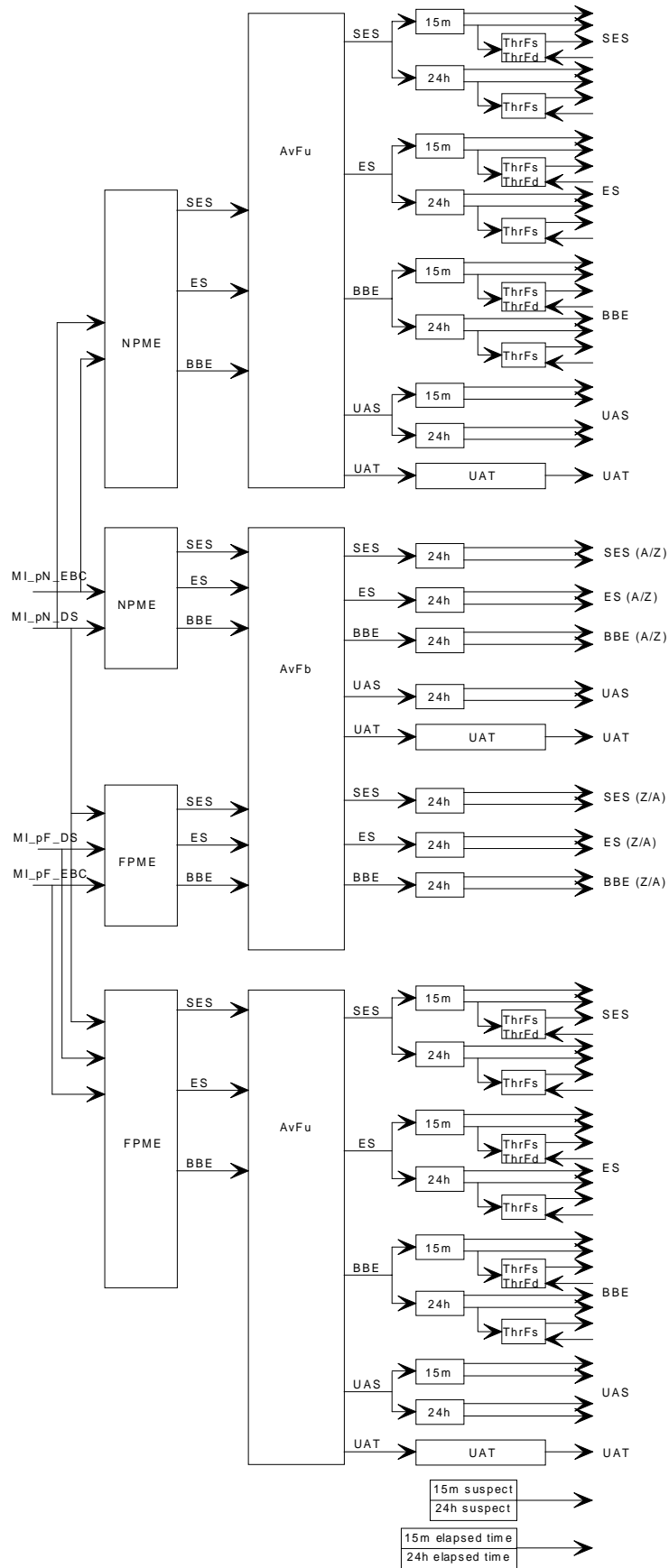

Figure C.2: Separate NPME and FPME for 2 Mbit/s termination points

---

## Bibliography

The following material, though not specifically referenced in the body of the present document (or not publicly available), gives supporting information.

- EN 300 417-2-1: "Transmission and Multiplexing (TM); Generic requirements of transport functionality of equipment; Part 2-1: Synchronous Digital Hierarchy (SDH) and Plesiochronous Digital Hierarchy (PDH) physical section layer functions".
- EN 300 417-3-1: "Transmission and Multiplexing (TM); Generic requirements of transport functionality of equipment; Part 3-1: Synchronous Transport Module-N (STM-N) regenerator and multiplex section layer functions".
- EN 300 417-5-1: "Transmission and Multiplexing (TM); Generic requirements of transport functionality of equipment; Part 5-1: Plesiochronous Digital Hierarchy (PDH) path layer functions".
- ITU-T Recommendation G.826 (1999): "Error performance parameters and objectives for international, constant bit rate digital paths at or above the primary rate".
- ITU-T Recommendation G.774.01 (1994): "Synchronous Digital Hierarchy (SDH) performance monitoring for the network element view".
- ITU-T Recommendation G.774.01 (1996): "Corrigendum 1".
- ITU-T Recommendation G.774.6 (1997): "Synchronous digital hierarchy (SDH) uni-directional performance monitoring for the network element view".
- ITU-T Recommendation G.841 (1998): "Types and characteristics of SDH network protection architectures".

---

## History

<b>Document history</b>		
V1.1.1	June 1999	Public Enquiry PE 9947: 1999-06-23 to 1999-11-19