

**Transmission and Multiplexing (TM);
Generic requirements of transport functionality of equipment;
Part 5-1: Plesiochronous Digital Hierarchy (PDH)
path layer functions**



Reference

REN/TM-01042-5-1

Keywordsarchitecture, PDH, SDH, transmission, transport,
path**ETSI**

650 Route des Lucioles
F-06921 Sophia Antipolis Cedex - FRANCE

Tel.: +33 4 92 94 42 00 Fax: +33 4 93 65 47 16

Siret N° 348 623 562 00017 - NAF 742 C
Association à but non lucratif enregistrée à la
Sous-Préfecture de Grasse (06) N° 7803/88

Important notice

Individual copies of the present document can be downloaded from:

<http://www.etsi.org>

The present document may be made available in more than one electronic version or in print. In any case of existing or perceived difference in contents between such versions, the reference version is the Portable Document Format (PDF). In case of dispute, the reference shall be the printing on ETSI printers of the PDF version kept on a specific network drive within ETSI Secretariat.

Users of the present document should be aware that the document may be subject to revision or change of status. Information on the current status of this and other ETSI documents is available at <http://www.etsi.org/tb/status/>

If you find errors in the present document, send your comment to:
editor@etsi.fr

Copyright Notification

No part may be reproduced except as authorized by written permission.
The copyright and the foregoing restriction extend to reproduction in all media.

© European Telecommunications Standards Institute 2001.
All rights reserved.

Contents

Intellectual Property Rights	7
Foreword.....	7
Introduction.....	8
1 Scope.....	9
2 References.....	9
3 Definitions, abbreviations and symbols	10
3.1 Definitions	10
3.2 Abbreviations.....	10
3.3 Symbols and Diagrammatic Conventions.....	12
4 P4e path layer functions	12
4.1 P4e connection functions.....	14
4.2 P4e trail termination functions.....	15
4.2.1 P4e trail termination source P4e_TT_So.....	15
4.2.2 P4e trail termination sink P4e_TT_Sk	16
4.3 P4e adaptation functions.....	17
4.3.1 P4e to P31x adaptation source P4e/P31x_A_So/i.....	17
4.3.2 P4e to P31x Adaptation Sink P4e/P31x_A_Sk/i.....	18
4.3.3 P4e to P31e adaptation source P4e/P31e_A_So/i.....	20
4.3.4 P4e to P31e adaptation sink P4e/P31e_A_Sk/i.....	21
4.3.5 P4e to P31s adaptation source P4e/P31s_A_So/i.....	23
4.3.6 P4e to P31s adaptation sink P4e/P31s_A_Sk/i	24
4.4 P4e layer monitoring functions	27
4.4.1 P4e layer non-intrusive monitoring function P4em_TT_Sk	27
4.5 P4e PDH equipment clock adaptation source P4e_PEC.....	28
5 P31e path layer functions	29
5.1 P31e connection functions.....	30
5.2 P31e trail termination functions	31
5.2.1 P31e trail termination source P31e_TT_So.....	31
5.2.2 P31e trail termination sink P31e_TT_Sk.....	32
5.3 P31e adaptation functions.....	33
5.3.1 P31e to P22x adaptation source P31e/P22x_A_So/i.....	33
5.3.2 P31e to P22x adaptation sink P31e/P22x_A_Sk/i.....	34
5.3.3 P31e to P22e adaptation source P31e/P22e_A_So/i.....	36
5.3.4 P31e to P22e adaptation sink P31e/P22e_A_Sk/i.....	38
5.4 P31e layer monitoring functions	39
5.4.1 P31e layer non-intrusive monitoring function P31em_TT_Sk	39
5.5 P31e PDH equipment clock adaptation source P31e_PEC.....	41
6 P22e path layer functions	42
6.1 P22e connection functions.....	43
6.2 P22e trail termination functions	44
6.2.1 P22e trail termination source P22e_TT_So.....	44
6.2.2 P22e trail termination sink P22e_TT_Sk.....	45
6.3 P22e adaptation functions.....	46
6.3.1 P22e to P12x adaptation source P22e/P12x_A_So/i.....	46
6.3.2 P22e to P12x adaptation sink P22e/P12x_A_Sk/i.....	48
6.3.3 P22e to P12s adaptation source P22e/P12s_A_So/i.....	50
6.3.4 P22e to P12s adaptation sink P22e/P12s_A_Sk/i.....	51
6.4 P22e layer monitoring functions	53
6.4.1 P22e layer non-intrusive monitoring function P22em_TT_Sk	53
6.5 P22e PDH equipment clock adaptation source P22e_PEC.....	54
7 P12s path layer functions	55

7.1	P12s connection functions	58
7.2	P12s trail termination functions	58
7.2.1	P12s trail termination source P12s_TT_So.....	58
7.2.2	P12s trail termination sink P12s_TT_Sk.....	59
7.3	P12s adaptation functions	62
7.3.1	P12s to P0-31c adaptation source P12s/P0-31c_A_So.....	62
7.3.2	P12s to P0-31c adaptation sink P12s/P0-31c_A_Sk	63
7.3.3	P12s to SD adaptation source P12s/SD_A_So.....	64
7.3.4	P12s to SD adaptation sink P12s/SD_A_Sk.....	64
7.3.5	P12s to ATM VP compound adaptation source P12s/Avp_A_So.....	64
7.3.6	P12s to ATM VP compound adaptation sink P12s/Avp_A_Sk	64
7.3.7	P12s Layer Clock adaptation source P12s-LC_A_So	64
7.3.8	P12s Layer to P0 layer compound adaptation source function P12s/P0X_A_So.....	64
7.3.8.1	P12s to P0G32 adaptation source P12s/P0G32_A_So.....	66
7.3.8.2	P0G32 termination source function P0G32_T_So.....	66
7.3.8.3	P0G32 to P0 layer adaptation source function P0G32/P0_A_So/M	67
7.3.8.4	P0G32 to P0-LAPD layer adaptation source function P0G32/P0-LAPD_A_So/M.....	68
7.3.9	P12s layer to P0X layer compound adaptation sink function P12s/P0X_A_Sk.....	70
7.3.9.1	P12s layer to P0G32 adaptation sink function P12s/P0G32_A_Sk	71
7.3.9.2	P0G32 termination sink function TUG_T_Sk.....	72
7.3.9.3	P0G32 to P0 layer adaptation sink function P0G32/P0_A_Sk/M.....	73
7.3.9.4	P0G32 to P0-LAPD layer adaptation sink function P0G32/P0-LAPD_A_Sk/M	74
7.3.10	P12s layer to V3-SM layer adaptation source function P12s/P0X_A_So.....	76
7.3.11	P12s layer to V3-SM layer adaptation source function P12s/P0X_A_Sk.....	76
7.4	P12s layer monitoring functions.....	76
7.4.1	P12s layer non-intrusive monitoring function P12sm_TT_Sk.....	76
8	P31s path layer functions	78
8.1	P31s connection functions	79
8.2	P31s trail termination functions	79
8.2.1	P31s trail termination source P31s_TT_So.....	79
8.2.2	P31s trail termination sink P31s_TT_Sk.....	80
8.3	P31s adaptation functions	82
8.3.1	P31s layer to VC-12, VC-11 layer compound adaptation source function P31s/SX_A_So	82
8.3.1.1	P31s layer to TUG adaptation source function P31s/TUG_A_So	84
8.3.1.2	TUG termination source function TUG_T_So	85
8.3.1.3	TUG to VC-12 layer adaptation source function TUG/S12_A_So/M	86
8.3.1.4	TUG to VC-11 layer adaptation source function TUG/S11_A_So/M	89
8.3.2	P31s layer to VC-12, VC-11 layer compound adaptation sink function P31s/SX_A_Sk.....	92
8.3.2.1	P31s layer to TUG adaptation sink function P31s/TUG_A_Sk.....	94
8.3.2.2	TUG termination sink function TUG_T_Sk.....	95
8.3.2.3	TUG to VC-12 layer adaptation sink function TUG/S12_A_Sk/M.....	96
8.3.2.4	TUG to VC-11 layer adaptation sink function TUG/S11*_A_Sk/M.....	97
8.3.3	P31s layer to P0s layer adaptation source P31s/P0s_A_So	98
8.3.4	P31s layer to P0s layer adaptation sink P31s/P0s_A_Sk.....	99
8.3.5	P31s to V0x adaptation source P31s/V0x_A_So	100
8.3.6	P31s to V0x adaptation sink P31s/V0x_A_Sk.....	101
8.3.7	P31s to DCC adaptation source P31s/DCC_A_So.....	102
8.3.8	P31s to DCC adaptation sink P31s/DCC_A_Sk	102
8.3.9	P31s to SD adaptation source P31s/SD_A_So.....	103
8.3.10	P31s to SD adaptation sink P31s/SD_A_Sk.....	103
8.3.11	P31s to ATM VP compound adaptation source P31s/Avp_A_So.....	103
8.3.12	P31s to ATM VP compound adaptation sink P31s/Avp_A_Sk	103
8.3.13	P31s Layer Clock adaptation source P31s-LC_A_So	103
8.4	P31s layer monitoring functions.....	104
8.4.1	P31s non-intrusive monitoring function P31sm_TT_Sk	104
8.5	P31s layer trail protection functions.....	106
8.6	P31s tandem connection sublayer functions	106
8.6.1	P31s tandem connection trail termination source function (P31sD_TT_So).....	106
8.6.2	P31s tandem connection trail termination sink function (P31sD_TT_Sk).....	109
8.6.3	P31s tandem connection to p31s adaptation source function (P31sD/P31s_A_So)	113
8.6.4	P31s tandem connection to p31s adaptation sink function (P31sD/P31s_A_Sk).....	114

8.6.5	P31s tandem connection non-intrusive trail termination sink function (P31sDm_TT_Sk).....	115
9	P4s path layer functions	118
9.1	P4s connection functions	119
9.2	P4s trail termination functions	120
9.2.1	P4s trail termination source P4s_TT_So	120
9.2.2	P4s trail termination sink P4s_TT_Sk.....	121
9.3	P4s adaptation functions.....	123
9.3.1	P4s layer to VC-3, VC-2, VC-12, and VC-11 layer compound adaptation source function P4s/SX-TUG3_A_So.....	123
9.3.1.1	P4s layer to TUG3 adaptation source function P4s/TUG3_A_So	124
9.3.1.2	TUG3 trail termination source function TUG3_T_So	126
9.3.1.3	TUG3 to VC-3 layer adaptation source function TUG3/S3_A_So/K.0.0	127
9.3.1.4	TUG3 to VC-2 layer adaptation source function TUG3/S2_A_So/K.L.0.....	129
9.3.1.5	TUG3 to VC-12 layer adaptation source function TUG3/S12_A_So/K.L.M.....	131
9.3.1.6	TUG3 to VC-11 layer adaptation source function TUG3/S11*_A_So/K.L.M.....	134
9.3.2	P4s layer to VC-3, VC-2, VC-12, and VC-11 layer compound adaptation sink function P4s/SX-TUG3_A_Sk.....	137
9.3.2.1	P4s layer to TUG3 adaptation sink function P4s/TUG3_A_Sk.....	139
9.3.2.2	TUG3 trail termination sink function TUG3_T_Sk.....	140
9.3.2.3	TUG3 to VC-3 layer adaptation sink function TUG3/S3_A_Sk/K.0.0.....	141
9.3.2.4	TUG3 to VC-2 layer adaptation sink function TUG3/S2_A_Sk	142
9.3.2.5	TUG3 to VC-12 layer adaptation sink function TUG3/S12_A_Sk/K.L.M.....	143
9.3.2.6	TUG3 to VC-11 layer adaptation sink function TUG3/S11*_A_Sk/K.L.M.....	145
9.3.3	P4s layer to VC-2, VC-12, and VC-11 layer compound adaptation source function P4s/SX-TUG2_A_So.....	146
9.3.3.1	P4s layer to TUG2 adaptation source function P4s/TUG2_A_So	148
9.3.3.2	TUG2 trail termination source function TUG2_T_So	149
9.3.3.3	TUG2 to VC-2 layer adaptation source function TUG2/S2_A_So/L.0.....	150
9.3.3.4	TUG2 to VC-12 layer adaptation source function TUG2/S12_A_So/L.M.....	152
9.3.3.5	TUG2 to VC-11 layer adaptation source function TUG2/S11*_A_So/L.M.....	155
9.3.4	P4s layer to VC-2, VC-12, and VC-11 layer compound adaptation sink function P4s/SX-TUG2_A_Sk.....	158
9.3.4.1	P4s layer to TUG2 adaptation sink function P4s/TUG2_A_Sk.....	160
9.3.4.2	TUG2 trail termination sink function TUG2_T_Sk.....	161
9.3.4.3	TUG2 to VC-2 layer adaptation sink function TUG2/S2_A_Sk/L.0.....	162
9.3.4.4	TUG2 to VC-12 layer adaptation sink function TUG2/S12_A_Sk/L.M.....	163
9.3.4.5	TUG2 to VC-11 layer adaptation sink function TUG2/S11*_A_Sk/L.M.....	164
9.3.5	P4s layer to P0s layer adaptation source P4s/P0s_A_So.....	165
9.3.6	P4s layer to P0s layer adaptation sink P4s/P0s_A_Sk.....	166
9.3.7	P4s to V0x adaptation source P4s/V0x_A_So.....	167
9.3.8	P4s to V0x adaptation sink P4s/V0x_A_Sk.....	168
9.3.9	P4s to DCC adaptation source P4s/DCC_A_So	169
9.3.10	P4s to DCC adaptation sink P4s/DCC_A_Sk.....	170
9.3.11	P4s to SD adaptation source P4s/SD_A_So	171
9.3.12	P4s to SD adaptation sink P4s/SD_A_Sk.....	171
9.3.13	P4s to ATM VP compound adaptation source P4s/Avp_A_So	171
9.3.14	P4s to ATM VP compound adaptation sink P4s/Avp_A_Sk.....	171
9.3.15	P4s Layer Clock adaptation source P4s-LC_A_So	171
9.4	P4s layer monitoring functions	171
9.4.1	P4s non-intrusive monitoring function P4sm_TT_Sk	171
9.5	P4s layer trail protection functions.....	173
9.6	P4s tandem connection sublayer functions	173
9.6.1	P4s tandem connection trail termination source function (P4sD_TT_So).....	173
9.6.2	P4s tandem connection trail termination sink function (P4sD_TT_Sk)	176
9.6.3	P4s tandem connection to p4s adaptation source function (P4sD/P4s_A_So).....	181
9.6.4	P4s tandem connection to p4s adaptation sink function (P4sD/P4s_A_Sk)	182
9.6.5	P4s tandem connection non-intrusive trail termination sink function (P4sDm_TT_Sk)	183
10	P4x path layer functions.....	186
11	P32x path layer functions.....	186

12	P31x path layer functions.....	186
13	P22x path layer functions.....	186
14	P12x path layer functions.....	186
15	P11x path layer functions.....	186
16	P0 path layer functions.....	187
16.1	P0 connection functions.....	188
16.1.1	P0 Trail Connection Function (P0_C).....	188
17	P0 trail termination functions	189
18	P0-31c path layer functions.....	189
Annex A (informative):	Relationship between TU-2/12 address, and location of columns within a P4s TUG3 structured payload.....	190
Annex B (informative):	Relationship between TU-2/12 address, and location of columns within a P4s TUG2 structured payload.....	193
Annex C (informative):	Bibliography.....	196
History		197

Intellectual Property Rights

IPRs essential or potentially essential to the present document may have been declared to ETSI. The information pertaining to these essential IPRs, if any, is publicly available for **ETSI members and non-members**, and can be found in ETSI SR 000 314: *"Intellectual Property Rights (IPRs); Essential, or potentially Essential, IPRs notified to ETSI in respect of ETSI standards"*, which is available from the ETSI Secretariat. Latest updates are available on the ETSI Web server (<http://www.etsi.org/ipr>).

Pursuant to the ETSI IPR Policy, no investigation, including IPR searches, has been carried out by ETSI. No guarantee can be given as to the existence of other IPRs not referenced in ETSI SR 000 314 (or the updates on the ETSI Web server) which are, or may be, or may become, essential to the present document.

Foreword

This European Standard (Telecommunications series) has been produced by ETSI Technical Committee Transmission and Multiplexing (TM), and is now submitted for the ETSI standards One-step Approval Procedure.

The present document is one of a family of documents that has been produced in order to provide inter-vendor and inter-operator compatibility of Synchronous Digital Hierarchy (SDH) equipment.

The present document is part 5-1 of a multi-part EN covering the Generic requirements of transport functionality of equipment, as identified below:

Part 1-1: "Generic processes and performance".

Part 1-2: "General information about Implementation Conformance Statement (ICS) proforma".

Part 2-1: "Synchronous Digital Hierarchy (SDH) and Plesiochronous Digital Hierarchy (PDH) physical section layer functions".

Part 2-2: "Synchronous Digital Hierarchy (SDH) and Plesiochronous Digital Hierarchy (PDH) physical section layer functions; Implementation Conformance Statement (ICS) proforma specification".

Part 3-1: "Synchronous Transport Module-N (STM-N) regenerator and multiplex section layer functions".

Part 3-2: "Synchronous Transport Module-N (STM-N) regenerator and multiplex section layer functions; Implementation Conformance Statement (ICS) proforma specification".

Part 4-1: "Synchronous Digital Hierarchy (SDH) path layer functions".

Part 4-2: "Synchronous Digital Hierarchy (SDH) path layer functions; Implementation Conformance Statement (ICS) proforma specification".

Part 5-1: "Plesiochronous Digital Hierarchy (PDH) path layer functions".

Part 5-2: "Plesiochronous Digital Hierarchy (PDH) path layer functions; Implementation Conformance Statement (ICS) proforma specification".

Part 6-1: "Synchronization layer functions".

Part 6-2: "Synchronization layer functions; Implementation Conformance Statement (ICS) proforma specification".

Part 7-1: "Equipment management functions and Auxiliary layer functions".

Part 7-2: "Equipment management functions and Auxiliary layer functions; Implementation Conformance Statement (ICS) proforma specification".

Part 9-1: "Synchronous Digital Hierarchy (SDH) concatenated path layer functions; Requirements".

Parts 2 to 7 specify the layers and their atomic functions.

NOTE: The SDH radio equipment functional blocks are addressed by ETSI WG TM4.

Various of the above parts have previously been published as parts of ETS 300 417.

Proposed national transposition dates	
Date of latest announcement of this EN (doa):	3 months after ETSI publication
Date of latest publication of new National Standard or endorsement of this EN (dop/e):	6 months after doa
Date of withdrawal of any conflicting National Standard (dow):	6 months after doa

Introduction

The atomic PDH path layer functions are defined below used in plesiochronous and synchronous operation. They describe the functionality of PDH multiplex equipments described in the ITU-T Recommendations G.751 [7] and G.742 [6] for signal hierarchies P4e, P31e and P22e. In addition they describe the functionality of synchronous PDH equipment described in ETS 300 167 [2] for P12s layer signals, and ETS 300 337 [10] for P31s and P4s signals.

1 Scope

The present document specifies a library of basic building blocks and a set of rules by which they are combined in order to describe a digital transmission equipment. The library comprises the functional building blocks needed to completely specify the generic functional structure of the European digital transmission hierarchy. Equipment which is compliant with the present document can be described as an interconnection of a subset of these functional blocks contained within the present document. The interconnections of these blocks should obey the combination rules given. The generic functionality is described in the EN 300 417-1-1 [9].

2 References

The following documents contain provisions which, through reference in this text, constitute provisions of the present document.

- References are either specific (identified by date of publication, edition number, version number, etc.) or non-specific.
- For a specific reference, subsequent revisions do not apply.
- For a non-specific reference, the latest version applies.

- [1] ETSI ETS 300 147: "Transmission and Multiplexing (TM); Synchronous Digital Hierarchy (SDH); Multiplexing structure".
- [2] ETSI ETS 300 167: "Transmission and Multiplexing (TM); Functional characteristics of 2 048 kbit/s interfaces".
- [3] ITU-T Recommendation G.703: "Physical/electrical characteristics of hierarchical digital interfaces".
- [4] ITU-T Recommendation G.704 (10/98): "Synchronous frame structures used at 1 544, 6 312, 2 048, 8 488 and 44 736 kbit/s hierarchical levels".
- [5] ITU-T Recommendation G.706: "Frame alignment and cyclic redundancy check (CRC) procedures relating to basic frame structures defined in recommendation G.704".
- [6] ITU-T Recommendation G.742 (1988): "Second order digital multiplex equipment operating at 8 448 kbit/s and using positive justification".
- [7] ITU-T Recommendation G.751 (1988): "Digital multiplex equipments operating at the third order bit rate of 34 368 kbit/s and the fourth order bit rate of 139 264 kbit/s and using positive justification".
- [8] ITU-T Recommendation G.823: "The control of jitter and wander within digital networks which are based on the 2 048 kbit/s hierarchy".
- [9] ETSI EN 300 417-1-1: "Transmission and Multiplexing (TM); Generic requirements of transport functionality of equipment; Part 1-1: Generic processes and performance".
- [10] ETSI ETS 300 337: "Transmission and Multiplexing (TM); Generic frame structures for the transport of various signals (including Asynchronous Transfer Mode (ATM) cells and Synchronous Digital Hierarchy (SDH) elements) at the ITU-T Recommendation G.702 hierarchical rates of 2 048 kbit/s, 34 368 kbit/s and 139 264 kbit/s".
- [11] ETSI EN 300 417-4-1: "Transmission and Multiplexing (TM); Generic requirements of transport functionality of equipment; Part 4-1: Synchronous Digital Hierarchy (SDH) path layer functions".
- [12] ETSI EN 300 417-6-1: "Transmission and Multiplexing (TM); Generic requirements of transport functionality of equipment; Part 6-1: Synchronization layer functions".

- [13] ETSI EN 301 163: "Transmission and Multiplexing (TM); Generic requirements of Asynchronous Transfer Mode (ATM) transport functionality within equipment".
- [14] ETSI ETS 300 166: "Transmission and Multiplexing (TM); Physical and electrical characteristics of hierarchical digital interfaces for equipment using the 2048 kbit/s - based plesiochronous or synchronous digital hierarchies".

3 Definitions, abbreviations and symbols

3.1 Definitions

The functional definitions are described in the EN 300 417-1-1 [9].

3.2 Abbreviations

For the purposes of the present document, the following abbreviations apply:

A	Adaptation function
AcTI	Accepted Trace Identifier
AI	Adapted Information
AIS	Alarm Indication Signal
AP	Access Point
ATM	Asynchronous Transfer Mode
Avp	ATM VP layer
BIP	Bit Interleaved Parity
C	Connection function
CH	CHannel
CI	Characteristic Information
CK	ClocK
CM	Connection Matrix
Co	Connection
CP	Connection Point
D	Data
DCC	Data Communications Channel
DEC	DECrement
DEG	DEGraded
DEGTHR	DEGraded THReshold
DL	Data Link
E12	Electrical interface signal 2 048 kbit/s
E31	Electrical interface signal 34 368 kbit/s
E4	Electrical interface signal 139 264 kbit/s
EBC	Errored Block Count
EDC	Error Detection Code
EDCV	Error Detection Code Violation
EMF	Equipment Management Function
EQ	EQuipment
Ex	ITU-T Recommendation G.703 [3] type Electrical signal, bit rate order x
ExTI	Expected Trace Identifier
F_B	Far-end Block
FAS	Frame Alignment Signal
FASE	Frame Alignment Signal Error
FO	Frame Offset information
FS	Frame Start signal
HO	Higher Order
ID	IDentifier
IF	In Frame state
INC	INCrement
IS	Intermediate System

ISDN	Integrated Services Digital Network
LC	Link Connection
LO	Lower Order
LOF	Loss Of Frame
LOM	Loss Of Multiframe
LOP	Loss Of Pointer
LT	Line Termination
MFP	MultiFrame Present
MI	Management Information
MON	MONitored
N_B	Near-end Block
NC	Network Connection
NCI	No CRC-4 Multiframe Indication
NE	Network Element
NU	National Use (bits, bytes)
OOF	Out Of Frame state
OS	Operations System
OS	Optical Section
OSC	OSCillator
P	Protection
P0s	64 kbit/s layer (transparent)
P11x	1 544 kbit/s layer (transparent)
P12s	2 048 kbit/s PDH path layer with synchronous 125 µs frame structure as specified in ETS 300 167 [2]
P12x	2 048 kbit/s layer (transparent)
P22e	8 448 kbit/s PDH path layer with 4 plesiochronous 2 048 kbit/s
P22x	8 448 kbit/s layer (transparent)
P31e	34 368 kbit/s PDH path layer with 4 plesiochronous 8 448 kbit/s
P31s	34 368 kbit/s PDH path layer with synchronous 125 µs frame structure as specified in ETS 300 337 [10]
P31x	34 368 kbit/s layer (transparent)
P32x	44 736 kbit/s layer (transparent)
P4e	139 264 kbit/s PDH path layer with 4 plesiochronous 34 368 kbit/s
P4s	139 264 kbit/s PDH path layer with synchronous 125 µs frame structure as specified in ETS 300 337 [10]
P4x	139 264 kbit/s layer (transparent)
PDH	Plesiochronous Digital Hierarchy
PEC	PDH Equipment Clock
PLM	PayLoad Mismatch
POH	Path OverHead
PRC	Primary Reference Clock
PS	Protection Switching
PU	PDH Unit
RDI	Remote Defect Indicator
REI	Remote Error Indicator
RI	Remote Information
RNCI	Remote No CRC-4 Multiframe Indication
RS	Regenerator Section
RS1	STM-1 Regenerator Section
RxTI	Received Trace identifier
SD	synchronization distribution layer, Signal Degrade
SES	Severely Errored Second
SF	Signal Fail
Sk	Sink
SNC	Sub-Network Connection
So	Source
SOH	Section OverHead
SSF	Server Signal Fail
SSM	Synchronization Status Message
TD	Transmit Degrade
TF	Transmit Fail

TI	Timing Information
TIM	Trace Identifier Mismatch
TM	Transmission_Medium
TP	Timing Point
TPmode	Termination Point mode
TR	Threshold Report
TS	Time Slot
TSD	Trail Signal Degrade
TSF	Trail Signal Fail
TT	Trail Termination function
TTI	Trail Trace Identifier
TU	Tributary Unit
TUG	Tributary Unit Group
TxTI	Transmitted Trace Identifier
UNEQ	Unequipped
VC	Virtual Container
VP	Virtual Path
W	Working

3.3 Symbols and Diagrammatic Conventions

The symbols and diagrammatic conventions are described in the EN 300 417-1-1 [9].

4 P4e path layer functions

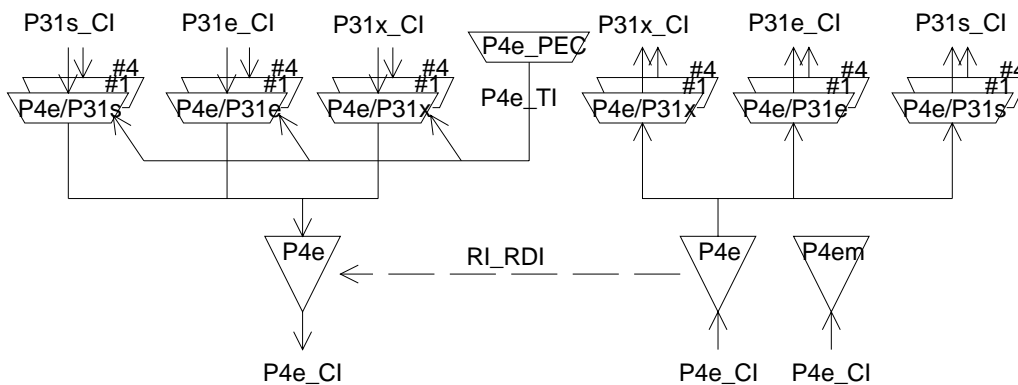

Figure 1: P4e path layer atomic functions

P4e layer CP

The Characteristic Information (CI) at this point is 139 264 kbit/s bit structured signal as specified in ITU-T Recommendation G.751 [7] with co-directional bit timing and the frame start information FS. The CI is structured to form a 2 928 bit long frame with 16 bit frame overhead containing 12 bit FAS, one bit RDI and a three bit user CI.

NOTE 1: The bits for National Use (NU) in row 4, columns 2 to 4 of figure 2 are reserved for operator specific usage. Their processing is not within the province of the present document.

P4e layer AP

The AI at this point is a multiplexed signal containing four $(728/2\ 928) \times 139\ 264$ kbit/s (see note 2) tributary signals (PU31) and $(3/2\ 928) \times 139\ 264$ kbit/s (see note 3) user CI (NU) with co-directional bit timing and frame start information.

NOTE 2: This equations equals a bitrate of 34 625,748 633 879 8 kbit/s.

NOTE 3: This equations equals a bitrate of 142,688 524 590 164 kbit/s.

The signal transported by an PU31 will be determined by the client layer application. Typical signals include:

- a 34 368 kbit/s signal P31x_CI without an assumed structure and justification overhead bits;
- a 34 368 kbit/s signal P31e_CI with a frame structure as specified in ITU-T Recommendation G.751 [7] and justification overhead bits;
- a 34 368 kbit/s signal P31s_CI with a frame structure as specified in ETS 300 337 [10] and justification overhead bits.

Figure 1 shows that more than one adaptation function exists in this P4e layer that can be connected to one P4e access point. For the case of the adaptation source functions, only one of these adaptation source functions is allowed to be activated. For this activated source, access to the access point by other adaptation source functions shall be denied. In contradiction with the source direction, adaptation sink functions may be activated all together. This may cause faults (e.g. cLOF) to be detected and reported. To prevent this an adaptation sink function can be deactivated.

NOTE 4: If one adaptation function only is connected to the AP, it will be activated. If one or more other functions are connected to the same AP, one out of the set of functions will be active.

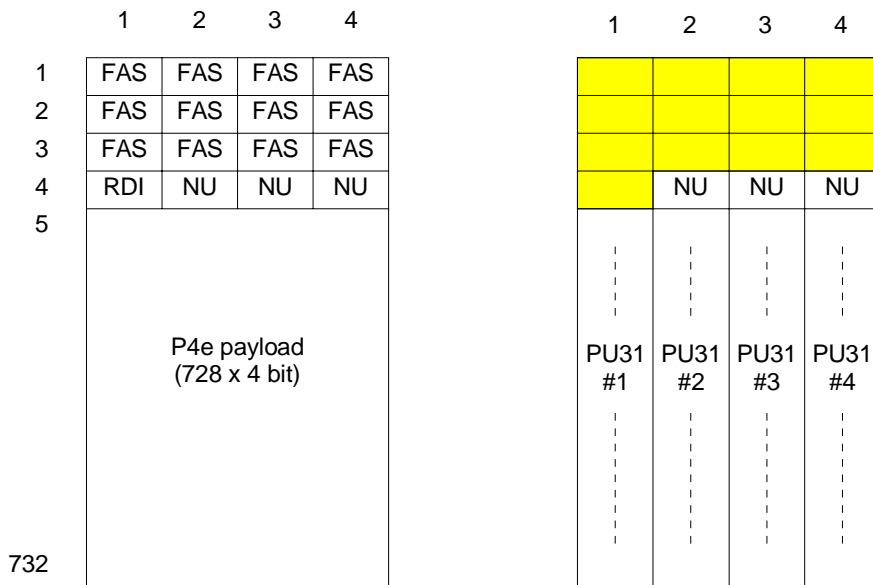

Figure 2: P4e_CI_D (left) and P4e_AI_D (right) signals

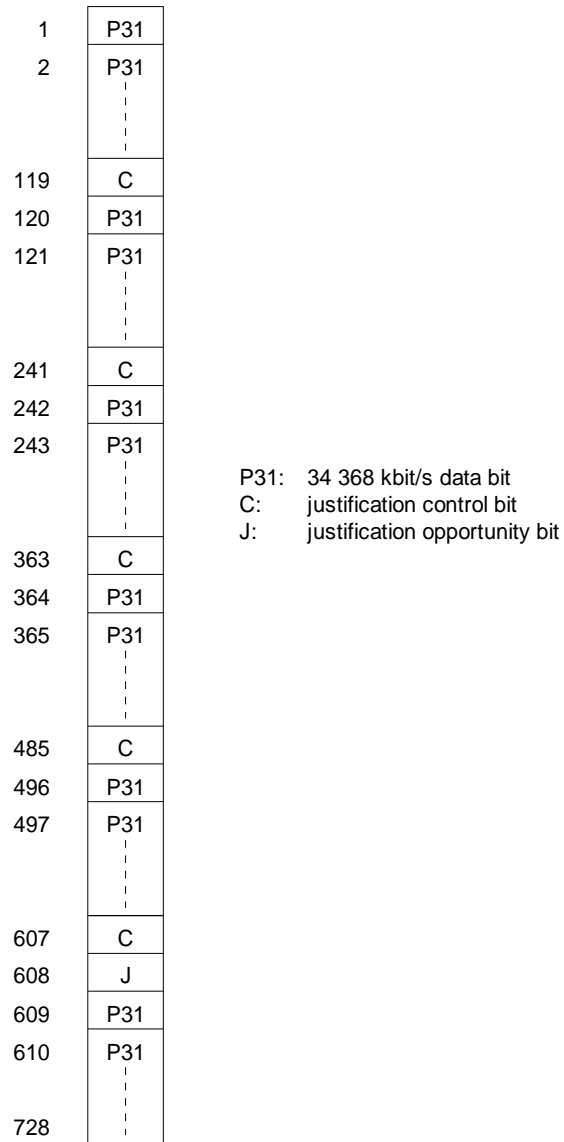

Figure 3: PU31 #i (i=1,2,3,4) of P4e_AI_D

4.1 P4e connection functions

For further study.

4.2 P4e trail termination functions

4.2.1 P4e trail termination source P4e_TT_So

Symbol:

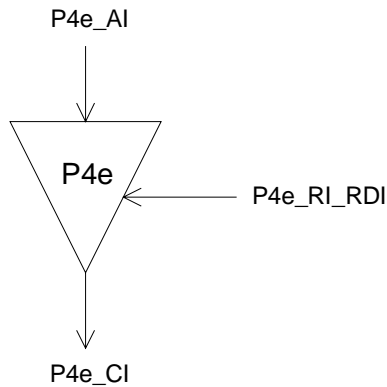

Figure 4: P4e_TT_So symbol

Interfaces:

Table 1: P4e_TT_So input and output signals

Input(s)	Output(s)
P4e_AI_D	P4e_CI_D
P4e_AI_CK	P4e_CI_CK
P4e_AI_FS	P4e_CI_FS
P4e_RI_RDI	

Processes:

This function adds the RDI information bit (see figure 2) and the frame alignment signal into the frame overhead. The frame overhead is defined as the first 16 bits of this frame as specified in ITU-T Recommendation G.751 [7], clause 1.5.2.

RDI: This bit represents the defect status of the associated P4e_TT_Sk. The RDI indication shall be set to "1" on activation of P4e_RI_RDI within 900 µs, determined by the associated P4e_TT_Sk function, and set to "0" within 900 µs on the P4e_RI_RDI removal.

Frame Alignment Signal (FAS): The function shall insert the 139 264 kbit/s frame alignment signal (111110100000) into the frame overhead.

Defects: none.

Consequent actions: none.

Defect correlations: none.

Performance monitoring: none.

4.2.2 P4e trail termination sink P4e_TT_Sk

Symbol:

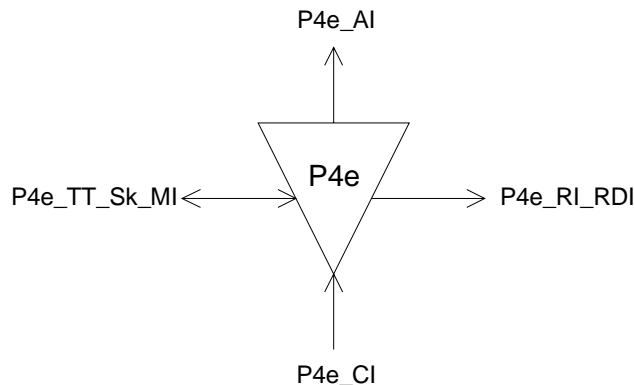

Figure 5: P4e_TT_Sk symbol

Interfaces:

Table 2: P4e_TT_Sk input and output signals

Input(s)	Output(s)
P4e_CI_D	P4e_AI_D
P4e_CI_CK	P4e_AI_CK
P4e_CI_FS	P4e_AI_FS
P4e_CI_SSF	P4e_AI_TSF
P4e_TT_Sk_MI_TPmode	P4e_RI_RDI
P4e_TT_Sk_MI_SSF_Reported	P4e_TT_Sk_MI_cRDI
P4e_TT_Sk_MI_RDI_Reported	P4e_TT_Sk_MI_cSSF
P4e_TT_Sk_MI_1second	P4e_TT_Sk_MI_pN_DS
	P4e_TT_Sk_MI_pN_EBC
	P4e_TT_Sk_MI_pF_DS

Processes:

This function recovers the RDI information bit (see figure 2) of the frame overhead as specified in ITU-T Recommendation G.751 [7], clause 1.5.2.

FAS: The FAS bits of each received frame are compared to their expected value "111110100000". A difference is taken as evidence of one or more errors (nN_B) in the block.

RDI: The information carried in the RDI bit shall be extracted to enable single ended maintenance of a bi-directional Trail (Path). The RDI (row 4, column 1) provides information as to the status of the remote receiver. A "1" indicates an RDI state, while a "0" indicates the normal, working state. The application process is described in EN 300 417-1-1 [9], clauses 7.4.11 and 8.2 (RDI).

Defects:

The function shall detect for dRDI defect according the specification in EN 300 417-1-1 [9], clause 8.2.1.

Consequent actions:

- aTSF ← CI_SSF;
- aRDI ← CI_SSF.

Defect correlations:

- cRDI ← dRDI and MON and RDI_Reported;
- cSSF ← CI_SSF and MON and SSF_Reported.

Performance monitoring:

The performance monitoring process shall be performed as specified in EN 300 417-1-1 [9], clauses 8.2.4 to 8.2.7.

NOTE: Whether or not performance monitoring is actually supported by a network element is determined by the presence of the element management performance monitoring functions.

- pN_DS ← aTSF or dEQ;
- pF_DS ← dRDI;
- pN_EBC ← $\sum nN_B$.

4.3 P4e adaptation functions

4.3.1 P4e to P31x adaptation source P4e/P31x_A_So/i

Symbol:

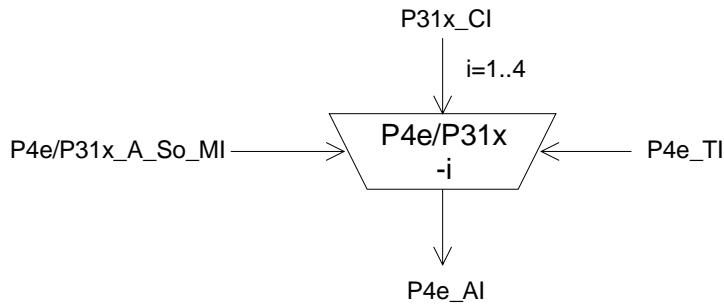

Figure 6: P4e/P31x_A_So symbol

Interfaces:

Table 3: P4e/P31x_A_So input and output signals

Input(s)	Output(s)
P31x_CI_D P31x_CI_CK P4e_TI_CK P4e_TI_FS P4e/P31x_A_So_MI_Active	P4e_AI_D P4e_AI_CK P4e_AI_FS

Processes:

This function maps one plesiochronous, 34 368 kbit/s, P31 information stream into the P4e frame (see figure 2), as specified in ITU-T Recommendation G.751 [7], clause 1.5.2. It takes P31x_CI, a bit-stream with a rate of 34 368 kbit/s \pm 20 ppm, present at its input and inserts it into the PU31 #i having a capacity of 728 bits and the justification frame as depicted in figure 3. The function can be activated/deactivated when multiple payload adaptation functions are connected to the access point.

Frequency justification and bitrate adaptation: The function shall provide for an elastic store (buffer) process. The data signal shall be written into the buffer under control of the associated input clock. The data signal shall be read out of the buffer under control of the P4e clock, frame position (P4e_TI), and justification decisions.

The justification decisions determine the phase error introduced by the P4e/P31x_A_So function. The amount of this phase error can be measured at the physical interfaces by monitoring the justification control bits C (see figure 3). An example is given in EN 300 417-4-1 [11], clause A.3.

Each justification decision results in a corresponding positive justification action. Upon a positive justification action, the reading of 1 data bit shall be cancelled once and no data is written at the justification opportunity bit J.

NOTE: A requirement for maximum introduced phase error generated by the justification process is for further study.

Buffer size: This justification process shall not introduce any errors when the input clock (P31x_CI_CK) has a frequency within the range 34 368 kbit/s \pm 20 ppm and a jitter specified by ITU-T Recommendation G.823 [8], and the P4e clock (P4e_TI_CK) has a frequency and jitter within the range specified in clause 4.5. Any step in frequency of the input clock within this range shall not cause any errors.

C bits - Justification control generation: The function shall generate the justification control (CCCCC) bits according the specification in ITU-T Recommendation G.751 [7]. It shall insert the justification control bits in the appropriate C bit positions.

PU-31 timeslot: The adaptation source function has access to a specific PU-31 of the P4e access point. The PU-31 is defined by the parameter i (i=1 to 4).

Activation: The function shall access the access point when it is activated (MI_Active is true). Otherwise, it shall not access the access point.

Defects: none.

Consequent actions: none.

Defect correlations: none.

Performance monitoring: none.

4.3.2 P4e to P31x Adaptation Sink P4e/P31x_A_Sk/i

Symbol:

Figure 7: P4e/P31x_A_Sk symbol

Interfaces:**Table 4: P4e/P31x_A_Sk input and output signals**

Input(s)	Output(s)
P4e_AI_D	P31x_CI_D
P4e_AI_CK	P31x_CI_CK
P4e_AI_FS	P31x_CI_SSF
P4e_AI_TSF	
P4e/P31x_A_Sk_ML_Active	

Processes:

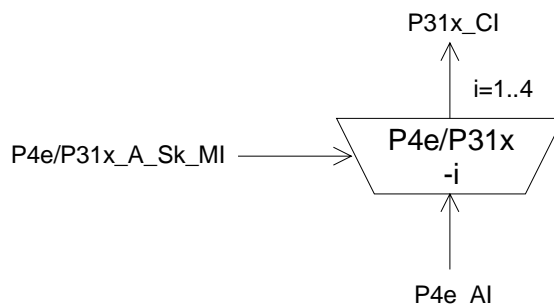
This function recovers one plesiochronous, 34 368 kbit/s, information stream P31 (see figures 2 and 3) from the P4e frame as specified in ITU-T Recommendation G.751 [7], clause 1.5.2. The function can be activated/deactivated when multiple payload adaptation functions are connected to the access point.

C bits - Justification control interpretation: The function shall perform justification control interpretation according ITU-T Recommendation G.751 [7] to recover the 34 368 kbit/s signal (P31) from the 139 264 kbit/s (P4e) payload signal. If the majority of the C bits is "0" the J bit shall be taken as a data bit, otherwise (majority of C bits is "1") J bit shall be taken as a justification bit and consequently ignored.

Smoothing & jitter limiting process: The function shall provide for a clock smoothing and elastic store (buffer) process. The 34 368 kbit/s data signal shall be written into the buffer under control of the associated (gapped) input clock. The data signal shall be read out of the buffer under control of a smoothed (equally spaced) 34 368 kHz \pm 20 ppm clock (the rate is determined by the 34 Mbit/s signal at the input of the remote P4e/P31x_A_So, P4e/P31e_A_So, or P4e/P31s_A_So).

The residual jitter caused by bit justifications (measured at the 34 368 kbit/s interface) shall be such that the peak-to-peak jitter at the 34 368 kbit/s output (being a tributary) in the absence of input jitter shall not exceed 0,3 UI when measured in the frequency range up to 800 kHz.

When measured with an instrument incorporating a bandpass filter having a lower cut-off frequency of 10 kHz, a roll-off of 20 dB/decade and an upper limit of 800 kHz, the peak-to-peak output jitter shall not exceed 0,05 UI with a probability of 99,9 % during a measurement period of 10 s.

Jitter transfer characteristic: A 34 368 kbit/s signal, modulated by sinusoidal jitter, applied to an adaptation source and retrieved from the adaptation sink, shall have a jitter transfer characteristic within the gain/frequency limits given in figure 8. The equivalent binary content of the test signal should be 1 000.

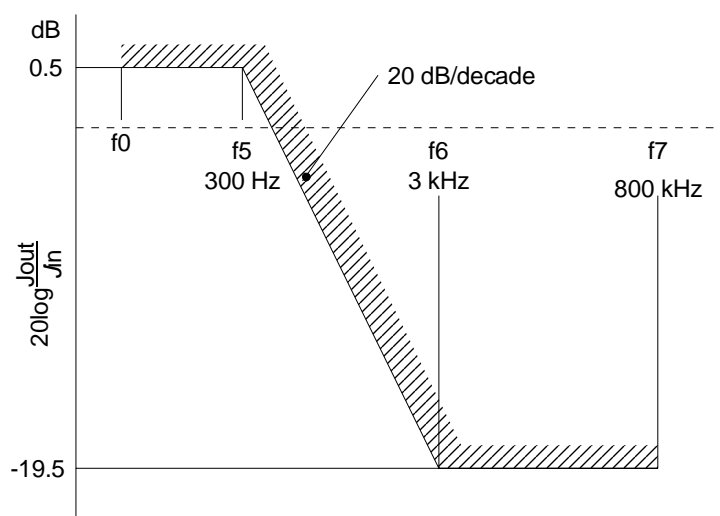

NOTE: The frequency f_0 shall be less than 20 Hz and as low as possible (e.g. 10 Hz), taking into account the limitations of measuring equipment.

Figure 8: Jitter transfer for 34 368 kbit/s signal

Buffer size: In the presence of jitter as specified in ITU-T Recommendation G.823 [8] and a frequency within the range 34 368 kbit/s ± 20 ppm, this justification process shall not introduce any errors.

Following a step in frequency of the P31x signal transported by the P4e_AI (for example due to reception of P31x CI from a new P31x_TT_So at the far end or removal of all-ONES (AIS) signal with a frequency offset) there will be a maximum recovery time of X seconds after which this process shall not generate any bit errors.

The value of X is for further study; a value of 1 second has been proposed.

PU-31 timeslot: The adaptation sink function has access to a specific PU-31 of the P4e access point. The PU-31 is defined by the parameter i (i=1 to 4).

Activation: The function shall perform the operation specified above when it is activated (MI_Active is true). Otherwise, it shall transmit the all-ONES signal at its output (CI_D) and not report its status via the management point.

Defects: none.

Consequent actions:

- aAIS ← AI_TSF;
- aSSF ← AI_TSF.

On declaration of aAIS the function shall output an all-ONES (AIS) signal - complying to the frequency limits for this signal (a bit rate in range 34 368 kbit/s ± 20 ppm) - within 900 µs; on clearing of aAIS the function shall output normal data within 900 µs.

Defects Correlations: none.

Performance monitoring: none.

4.3.3 P4e to P31e adaptation source P4e/P31e_A_So/i

Symbol:

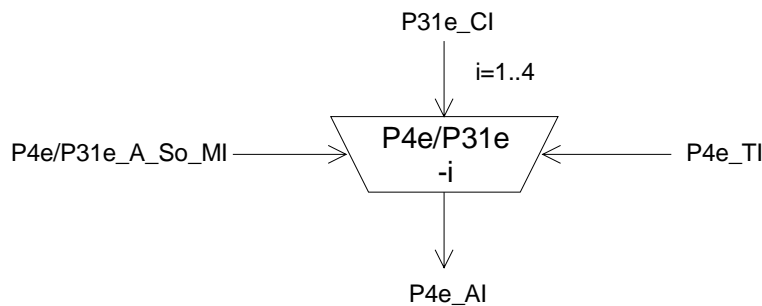

Figure 9: P4e/P31e_A_So symbol

Interfaces:

Table 5: P4e/P31e_A_So input and output signals

Input(s)	Output(s)
P31e_CI_D	P4e_AI_D
P31e_CI_CK	P4e_AI_CK
P31e_CI_FS	P4e_AI_FS
P4e_TI_CK	
P4e_TI_FS	
P4e/P31e_A_So_MI_Active	

Processes:

This function maps one plesiochronous, 34 368 kbit/s, P31 information stream into the P4e frame (see figure 2), as specified in ITU-T Recommendation G.751 [7], clause 1.5.2. It takes P31e_CI, a bit-stream with a rate of 34 368 kbit/s \pm 20 ppm, present at its input and inserts it into the PU31 #i having a capacity of 728 bits and the justification frame as depicted in figure 3. The function can be activated/deactivated when multiple payload adaptation functions are connected to the access point.

Frequency justification and bitrate adaptation: The function shall provide for an elastic store (buffer) process. The data signal shall be written into the buffer under control of the associated input clock. The data signal shall be read out of the buffer under control of the P4e clock, frame position (P4e_TI), and justification decisions.

The justification decisions determine the phase error introduced by the P4e/P31e_A_So function. The amount of this phase error can be measured at the physical interfaces by monitoring the justification control bits C (see figure 3). An example is given in EN 300 417-4-1 [11], clause A.3.

Each justification decision results in a corresponding positive justification action. Upon a positive justification action, the reading of 1 data bit shall be cancelled once and no data is written at the justification opportunity bit J.

NOTE: A requirement for maximum introduced phase error generated by the justification process is for further study.

Buffer size: This justification process shall not introduce any errors when the input clock (P31e CI_CK) has a frequency within the range 34 368 kbit/s \pm 20 ppm and a jitter specified by ITU-T Recommendation G.823 [8], and the P4e clock (P4e_TI_CK) has a frequency and jitter within the range specified in clause 4.5. Any step in frequency of the input clock within this range shall not cause any errors.

C bits - Justification control generation: The function shall generate the justification control (CCCCC) bits according the specification in ITU-T Recommendation G.751 [7]. It shall insert the justification control bits in the appropriate C bit positions.

PU-31 timeslot: The adaptation source function has access to a specific PU-31 of the P4e access point. The PU-31 is defined by the parameter i (i=1 to 4).

Activation: The function shall access the access point when it is activated (MI_Active is true). Otherwise, it shall not access the access point.

Defects: none.

Consequent actions: none.

Defect correlations: none.

Performance monitoring: none.

4.3.4 P4e to P31e adaptation sink P4e/P31e_A_Sk/i

Symbol:

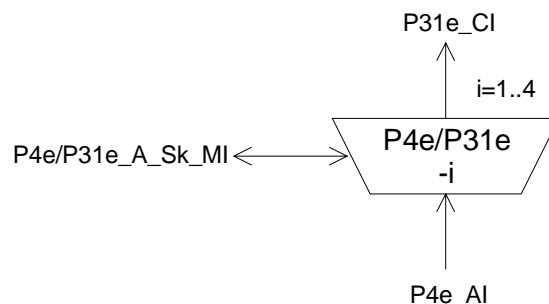

Figure 10: P4e/P31e_A_Sk symbol

Interfaces:**Table 6: P4e/P31e_A_Sk input and output signals**

Input(s)	Output(s)
P4e_AI_D	P31e_CI_D
P4e_AI_CK	P31e_CI_CK
P4e_AI_FS	P31e_CI_FS
P4e_AI_TSF	P31e_CI_SSF
P4e/P31e_A_Sk_MI_Active	P4e/P31e_A_Sk_MI_cLOF
P4e/P31e_A_Sk_MI_AIS_Reported	P4e/P31e_A_Sk_MI_cAIS

Processes:

This function recovers one plesiochronous, 34 368 kbit/s, information stream P31 (see figures 2 and 3) from the P4e frame as specified in ITU-T Recommendation G.751 [7], clause 1.5.2. Further it recovers the frame start information for the P31 tributary signal. The function can be activated/deactivated when multiple payload adaptation functions are connected to the access point.

C bits - Justification control interpretation: The function shall perform justification control interpretation according ITU-T Recommendation G.751 [7] to recover the 34 368 kbit/s signal (P31) from the 139 264 kbit/s (P4e) payload signal. If the majority of the C bits is "0" the J bit shall be taken as a data bit, otherwise (majority of C bits is "1") J bit shall be taken as a justification bit and consequently ignored.

Smoothing & jitter limiting process: The function shall provide for a clock smoothing and elastic store (buffer) process. The 34 368 kbit/s data signal shall be written into the buffer under control of the associated (gapped) input clock. The data signal shall be read out of the buffer under control of a smoothed (equally spaced) 34 368 kHz \pm 20 ppm clock (the rate is determined by the 34 Mbit/s signal at the input of the remote P4e/P31e_A_So).

The residual jitter caused by bit justifications is for further study.

Buffer size: In the presence of jitter as specified in ITU-T Recommendation G.823 [8] and a frequency within the range 34 368 kbit/s \pm 20 ppm, this justification process shall not introduce any errors.

Following a step in frequency of the P31e signal transported by the P4e_AI (for example due to reception of P31e CI from a new P31e_TT_So at the far end or removal of all-ONEs (AIS) signal with a frequency offset) there will be a maximum recovery time of X seconds after which this process shall not generate any bit errors.

The value of X is for further study; a value of 1 second has been proposed.

PU-31 timeslot: The adaptation sink function has access to a specific PU-31 of the P4e access point. The PU-31 is defined by the parameter i (i=1 to 4).

Activation: The function shall perform the operation specified above when it is activated (MI_Active is true). Otherwise, it shall transmit the all-ONEs signal at its output (CI_D) and not report its status via the management point.

Frame alignment: The function shall perform the frame alignment of the 34 368 kbit/s signal to recover the frame start signal FS. Loss of frame alignment shall be assumed to have taken place when four consecutive frame alignment signals have been incorrectly received in their predicted positions.

When frame alignment is assumed to be lost, the frame alignment device shall decide that such alignment has effectively been recovered when it detects the presence of three consecutive frame alignment signals.

The frame alignment device having detected the appearance of a single correct frame alignment signal, shall begin a new search for the frame alignment signal when it detects the absence of the frame alignment signal in one of the two following frames.

Defects:

The function shall detect a loss of frame defect (dLOF) when four consecutive frame alignment signals have been incorrectly received in their predicted positions. When frame alignment is lost, the dLOF defect shall be cleared when three consecutive frame alignment signals are detected.

The function shall detect an AIS defect (dAIS) according the specification in clause 8.2.1.7 in EN 300 417-1-1 [9], with X = 4, Y = 1 536, Z = 5.

Consequent actions:

- aAIS ← dAIS or dLOF;
- aSSF ← dAIS or dLOF.

On declaration of aAIS the function shall output an all-ONES (AIS) signal - complying to the frequency limits for this signal (a bit rate in range 34 368 kbit/s ± 20 ppm) - within 900 µs; on clearing of aAIS the function shall output normal data within 900 µs.

Defect correlations:

- cAIS ← dAIS and (not AI_TSF) and AIS_Reported
- cLOF ← dLOF and not dAIS.

Performance monitoring: none.

4.3.5 P4e to P31s adaptation source P4e/P31s_A_So/i

Symbol:

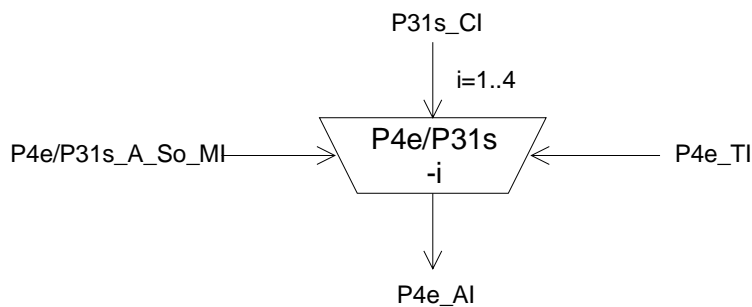

Figure 11: P4e/P31s_A_So symbol

Interfaces:

Table 7: P4e/P31s_A_So input and output signals

Input(s)	Output(s)
P31s_CI_D	P4e_AI_D
P31s_CI_CK	P4e_AI_CK
P4e_TI_CK	P4e_AI_FS
P4e_TI_FS	
P4e/P31s_A_So_MI_Active	

Processes:

This function maps one synchronous, 34 368 kbit/s, P31s information stream into the P4e frame (see figure 2), as specified in ITU-T Recommendation G.751 [7], clause 1.5.2. It takes P31s_CI, a bit-stream with a rate of 34 368 kbit/s ± 4,6 ppm (see note 1), present at its input and inserts it into the PU31 #i having a capacity of 728 bits and the justification frame as depicted in figure 3. The function can be activated/deactivated when multiple payload adaptation functions are connected to the access point.

NOTE 1: The 34 368 Mbit/s with a 125 µs frame according ETS 300 337 [10] is nominally locked to a PRC.

Frequency justification and bitrate adaptation: The function shall provide for an elastic store (buffer) process. The data signal shall be written into the buffer under control of the associated input clock. The data signal shall be read out of the buffer under control of the P4e clock, frame position (P4e_TI), and justification decisions.

The justification decisions determine the phase error introduced by the P4e/P31s_A_So function. The amount of this phase error can be measured at the physical interfaces by monitoring the justification control bits C (see figure 3). An example is given in EN 300 417-4-1 [11], clause A.3.

Each justification decision results in a corresponding positive justification action. Upon a positive justification action, the reading of 1 data bit shall be cancelled once and no data are written at the justification opportunity bit J.

NOTE 2: A requirement for maximum introduced phase error generated by the justification process is for further study.

Buffer size: This justification process shall not introduce any errors when the input clock (P31s CI_CK) has a frequency within the range 34 368 kbit/s ± 20 ppm and a jitter specified by ITU-T Recommendation G.823 [8], and the P4e clock (P4e_TI_CK) has a frequency and jitter within the range specified in clause 4.5. Any step in frequency of the input clock within this range shall not cause any errors.

C bits - Justification control generation: The function shall generate the justification control (CCCCC) bits according the specification in ITU-T Recommendation G.751 [7]. It shall insert the justification control bits in the appropriate C bit positions.

PU-31 timeslot: The adaptation source function has access to a specific PU-31 of the P4e access point. The PU-31 is defined by the parameter i (i=1 to 4).

Activation: The function shall access the access point when it is activated (MI_Active is true). Otherwise, it shall not access the access point.

- Defects:** none.
- Consequent actions:** none.
- Defect correlations:** none.
- Performance monitoring:** none.

4.3.6 P4e to P31s adaptation sink P4e/P31s_A_Sk/i

Symbol:

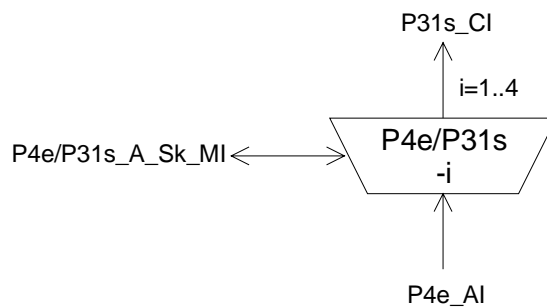

Figure 12: P4e/P31s_A_Sk symbol

Interfaces:

Table 8: P4e/P31s_A_Sk input and output signals

Input(s)	Output(s)
P4e_AI_D	P31s_CI_D
P4e_AI_CK	P31s_CI_CK
P4e_AI_FS	P31s_CI_FS
P4e_AI_TSF	P31s_CI_SSF
P4e/P31s_A_Sk_MI_Active	P4e/P31s_A_Sk_MI_cLOF
P4e/P31s_A_Sk_MI_AIS_Reported	P4e/P31s_A_Sk_MI_cAIS

Processes:

This function recovers one plesiochronous, 34 368 kbit/s, information stream P31 (see figures 2 and 3) from the P4e frame as specified in ITU-T Recommendation G.751 [7], clause 1.5.2. Further it recovers the frame start information for the P31 tributary signal. The function can be activated/deactivated when multiple payload adaptation functions are connected to the access point. It supplies the recovered timing signal to the synchronization distribution layer.

C bits - Justification control interpretation: The function shall perform justification control interpretation according ITU-T Recommendation G.751 [7] to recover the 34 368 kbit/s signal (P31) from the 139 264 kbit/s (P4e) payload signal. If the majority of the C bits is "0" the J bit shall be taken as a data bit, otherwise (majority of C bits is "1") J bit shall be taken as a justification bit and consequently ignored.

Smoothing & jitter limiting process: The function shall provide for a clock smoothing and elastic store (buffer) process. The 34 368 kbit/s data signal shall be written into the buffer under control of the associated (gapped) input clock. The data signal shall be read out of the buffer under control of a smoothed (equally spaced) 34 368 kHz \pm 20 ppm clock (the rate is determined by the 34 Mbit/s signal at the input of the remote P4e/P31s_A_So).

NOTE 1: The P31s signal is nominally locked to a PRC. Under fault conditions however, the P31s signal is replaced by an all-ONEs (AIS) signal with 20 ppm frequency tolerance.

The residual jitter caused by bit justifications is for further study.

Buffer size: In the presence of jitter as specified ITU-T Recommendation G.823 [8] and a frequency within the range 34 368 kbit/s \pm 20 ppm, this justification process shall not introduce any errors.

Following a step in frequency of the P31s signal transported by the P4e_AI (for example due to reception of P31s CI from a new P31s_TT_So at the far end or removal of all-ONEs (AIS) signal with a frequency offset) there will be a maximum recovery time of X seconds after which this process shall not generate any bit errors.

The value of X is for further study; a value of 1 second has been proposed.

PU-31 timeslot: The adaptation sink function has access to a specific PU-31 of the P4e access point. The PU-31 is defined by the parameter i (i=1 to 4).

Activation: The function shall perform the operation specified above when it is activated (MI_Active is true). Otherwise, it shall transmit the all-ONEs signal at its output (CI_D) and not report its status via the management point.

Frame alignment: The function shall perform the frame alignment of the 34 368 kbit/s signal to recover the frame start information FS. The frame alignment shall be found by searching for the A1, A2 bytes contained in the 34 Mbit/s signal. The frame signal shall be continuously checked with the presumed frame start position for the alignment. Frame alignment is deemed to have been lost when either:

- four consecutive FAS are detected in error (i.e. \geq 1 error in each FAS);
- 986 or more frames with one or more BIP8 violations (\geq 986 BIPV) are detected in a block of 1 000 frames (125 ms).

Frame alignment is deemed to have been recovered when three consecutive non-errored FAS are found.

Should a research for frame alignment be initiated either due to:

- a fortuitous FAS position being found once and not being found a second time in its expected position;
- exceeding the threshold which indicates false alignment.

Then the new search for frame alignment should start 1 bit displaced forward from the position of the last indication of frame alignment.

NOTE 2: The above is required in order to avoid repeated alignment on to a simulation of the framing location.

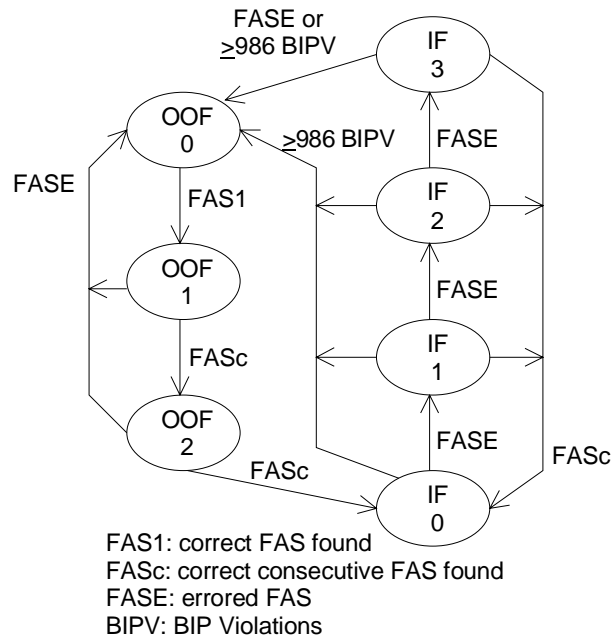

Figure 13: Frame alignment state diagram

Defects:

If the frame alignment state machine is in (one of) the OOF state(s), a 34 Mbit/s Loss Of Frame defect (dLOF) shall be detected. The dLOF defect shall be cleared when the frame alignment state machine is in (one of) the IF state(s).

The dAIS defect shall be detected as defined in EN 300 417-1-1 [9], clause 8.2.1.7 for 34 Mbit/s, with X = 7, Y = 4296, Z = 8.

Consequent actions:

aAIS ← dAIS or dLOF;

aSSF ← dAIS or dLOF.

On declaration of aAIS the function shall output an all-ONEs (AIS) signal - complying to the frequency limits for this signal (a bit rate in range 34 368 kbit/s \pm 20 ppm) - within 250 μ s; on clearing of aAIS the function shall output normal data within 250 μ s.

Defect correlations:

cAIS ← dAIS and (not AI_TSF) and AIS_Reported;

cLOF ← dLOF and (not dAIS).

Performance monitoring: none.

4.4 P4e layer monitoring functions

4.4.1 P4e layer non-intrusive monitoring function P4em_TT_Sk

Symbol:

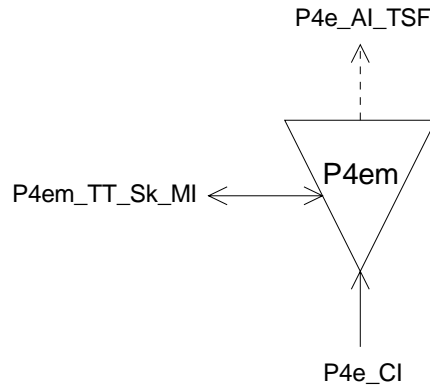

Figure 14: P4em_TT_Sk symbol

Interfaces:

Table 9: P4em_TT_Sk input and output signals

Input(s)	Output(s)
P4e_CI_D	P4e_AI_TSF
P4e_CI_CK	P4em_TT_Sk_MI_cRDI
P4e_CI_FS	P4em_TT_Sk_MI_cSSF
P4e_CI_SSF	P4em_TT_Sk_MI_pN_DS
P4em_TT_Sk_MI_TPmode	P4em_TT_Sk_MI_pN_EBC
P4em_TT_Sk_MI_SSF_Reported	P4em_TT_Sk_MI_pF_DS
P4em_TT_Sk_MI_RDI_Reported	
P4em_TT_Sk_MI_1second	

Processes:

This function recovers the RDI information bit (see figure 2) of the frame overhead as specified in ITU-T Recommendation G.751 [7], clause 1.5.2.

RDI: The information carried in the RDI bit shall be extracted to enable single ended maintenance of a bi-directional Trail (Path). The RDI (row 4, column 1) provides information as to the status of the remote receiver. A "1" indicates a Remote Defect Indication state, while a "0" indicates the normal, working state. The application process is described in EN 300 417-1-1 [9], clauses 7.4.11 and 8.2 (RDI).

Defects:

The function shall detect for dRDI defect according to the specification in EN 300 417-1-1 [9], clause 8.2.1.

Consequent actions:

aTSF ← CI_SSF

Defect correlations:

cRDI ← dRDI and MON and RDI_Reported
 cSSF ← CI_SSF and MON and SSF_Reported

Performance monitoring:

The performance monitoring process shall be performed as specified in EN 300 417-1-1 [9], clauses 8.2.4 to 8.2.7 (see note).

NOTE: Whether or not performance monitoring is actually supported by a network element is determined by the presence of the element management performance monitoring functions.

A near-end block is errored (nN_B) if one or more FAS bits are errored.

pN_DS ← aTSF or dEQ
 pF_DS ← dRDI
 pN_EBC ← Σ nN_B

4.5 P4e PDH equipment clock adaptation source P4e_PEC

Symbol:

Figure 15: P4e_PEC_A_So symbol

Interfaces:

Table 10: P4e_PEC_A_So input and output signals

Input(s)	Output(s)
	P4e_TI_CK P4e_TI_FS

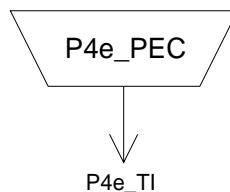
Processes:

This function performs the 140 Mbit/s clock and frame start signal generation to time the adaptation source functions in this layer.

Clock generation: The function shall generate the clock (bit) reference signal P4e_TI_CK for the P4e signal. The P4e_TI_CK bit rate shall be in range of 139 264 kbit/s \pm 15 ppm.

Jitter limiter: The function shall generate the clock signal such that the peak-to-peak jitter at the 139 264 kbit/s output shall not exceed 0,05 UI when it is measured within the frequency range from 200 Hz to 3 500 kHz.

Frame Start signal generation: The function shall generate the frame start reference signal P4e_TI_FS for the P4e signal. The P4e_TI_FS signal shall be active once per 2 928 bits.

Defects: none.

Consequent actions: none.

Defect correlations: none.

Performance monitoring: none.

5 P31e path layer functions

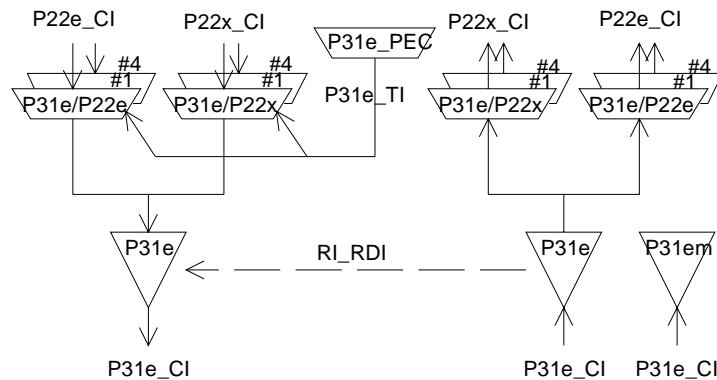

Figure 16: P31e path layer atomic functions

P31e layer CP.

The CI at this point is 34 368 kbit/s bit structured signal as specified in ITU-T Recommendation G.751 [7] with co-directional bit timing and the frame start information FS. The CI is structured to form a 1 536 bit long frame with 12 bit frame overhead containing 10 bit FAS, one bit RDI and one bit user CI.

NOTE 1: The bit for National Use (NU) in row 3, column 4 of figure 17 are reserved for operator specific usage. Their processing is not within the province of the present document.

P31e layer AP.

The AI at this point is a multiplexed signal containing four $(381/1\ 536) \times 34\ 368$ kbit/s (see note 2) tributary signals (PU22) and 22 375 bit/s User Characteristic Information (NU) with co-directional bit timing and frame start information.

NOTE 2: This equation equals a bitrate of 8 524,875 kbit/s.

The signal transported by an PU22 will be determined by the client layer application. Typical signals include:

- a 8 448 kbit/s signal P22x_CI without an assumed structure and justification overhead bits;
- a 8 448 kbit/s signal P22e_CI with a frame structure according ITU-T Recommendation G.742 [6] and justification overhead bits.

Figure 16 shows that more than one adaptation function exists in this P31e layer that can be connected to one P31e access point. For the case of the adaptation source functions, only one of these adaptation source functions is allowed to be activated. For this activated source, access to the access point by other adaptation source functions shall be denied. In contradiction with the source direction, adaptation sink functions may be activated all together. This may cause faults (e.g. cLOF) to be detected and reported. To prevent this an adaptation sink function can be deactivated.

NOTE 3: If one adaptation function only is connected to the AP, it will be activated. If one or more other functions are connected to the same AP, one out of the set of functions will be active.

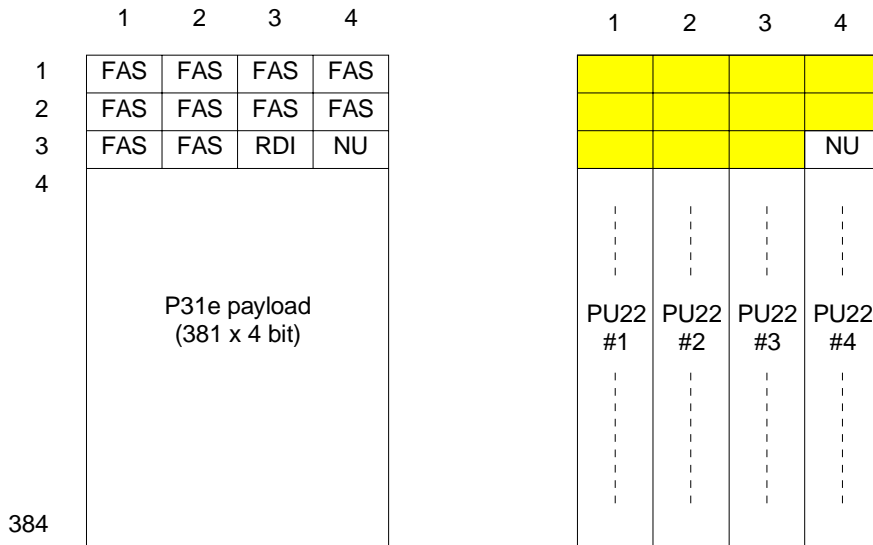

Figure 17: P31e_CI_D (left) and P31e_AI_D (right) signals

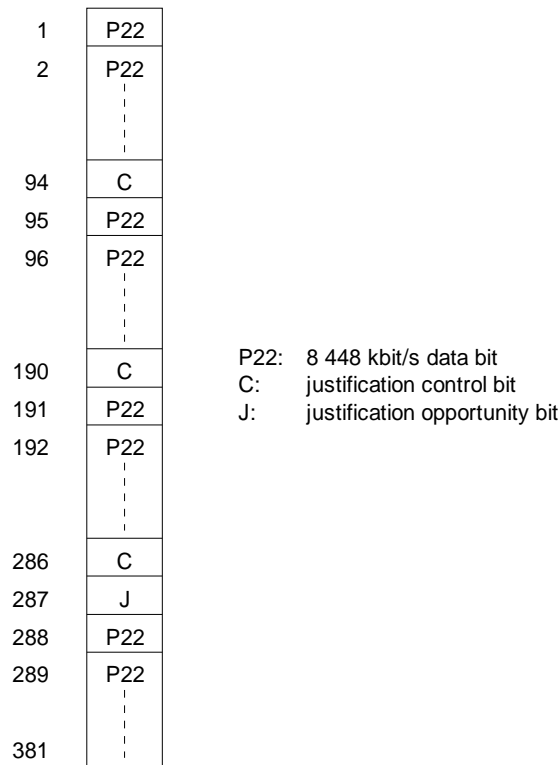

Figure 18: PU22 #i (i=1,2,3,4) of P31e_AI_D

5.1 P31e connection functions

For further study.

5.2 P31e trail termination functions

5.2.1 P31e trail termination source P31e_TT_So

Symbol:

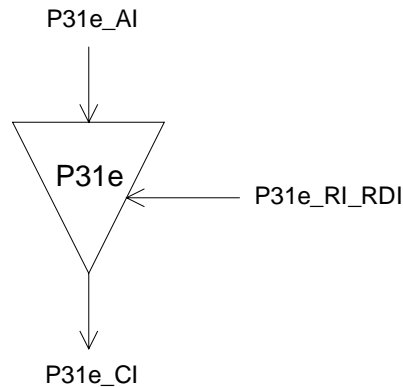

Figure 19: P31e_TT_So symbol

Interfaces:

Table 11: P31e_TT_So input and output signals

Input(s)	Output(s)
P31e_AI_D	P31e_CI_D
P31e_AI_CK	P31e_CI_CK
P31e_AI_FS	P31e_CI_FS
P31e_RI_RDI	

Processes:

This function adds the RDI information bit (see figure 17) and the frame alignment signal into the frame overhead. The frame overhead is defined as the first 12 bits of this frame according the ITU-T Recommendation G.751 [7], clause 1.4.2.

RDI: This bit represents the defect status of the associated P31e_TT_Sk. The RDI indication shall be set to "1" on activation of P31e_RI_RDI within 800 μ s, determined by the associated P31e_TT_Sk function, and set to "0" within 800 μ s on the P31e_RI_RDI removal.

Frame Alignment Signal (FAS): The function shall insert the 34 368 kbit/s frame alignment signal (1111010000) into the frame overhead.

Defects: none.

Consequent actions: none.

Defect correlations: none.

Performance monitoring: none.

5.2.2 P31e trail termination sink P31e_TT_Sk

Symbol:

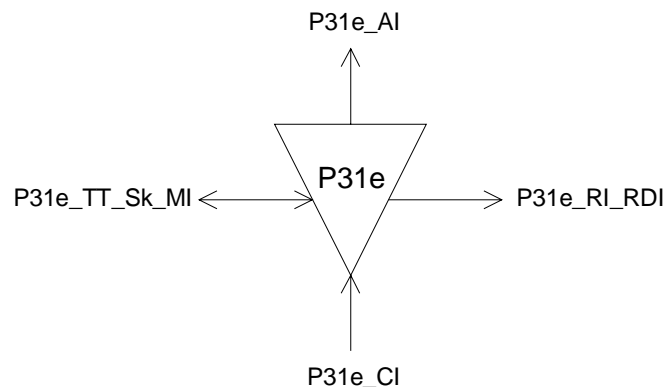

Figure 20: P31e_TT_Sk symbol

Interfaces:

Table 12: P31e_TT_Sk input and output signals

Input(s)	Output(s)
P31e_CI_D	P31e_AI_D
P31e_CI_CK	P31e_AI_CK
P31e_CI_FS	P31e_AI_FS
P31e_CI_SSF	P31e_AI_TSF
P31e_TT_Sk_MI_TPmode	P31e_RI_RDI
P31e_TT_Sk_MI_SSF_Reported	P31e_TT_Sk_MI_cRDI
P31e_TT_Sk_MI_RDI_Reported	P31e_TT_Sk_MI_cSSF
P31e_TT_Sk_MI_1second	P31e_TT_Sk_M)_pN_DS
	P31e_TT_Sk_M)_pN_EBC
	P31e_TT_Sk_M)_pF_DS

Processes:

This function recovers the RDI information bit (see figure 17) of the frame overhead as specified in ITU-T Recommendation G.751 [7], clause 1.4.2.

FAS: The FAS bits of each received frame are compared to their expected value "1111010000". A difference is taken as evidence of one or more errors (nN_B) in the block.

RDI: The information carried in the RDI bit shall be extracted to enable single ended maintenance of a bi-directional Trail (Path). The RDI (row 3, column 3) provides information as to the status of the remote receiver. A "1" indicates a Remote Defect Indication state, while a "0" indicates the normal, working state. The application process is described in EN 300 417-1-1 [9], clauses 7.4.11 and 8.2 (RDI).

Defects:

The function shall detect for dRDI defect according the specification in EN 300 417-1-1 [9], clause 8.2.1.

Consequent actions:

- aTSF ← CI_SSF
- aRDI ← CI_SSF

Defect correlations:

- cRDI ← dRDI and MON and RDI_Reported
- cSSF ← CI_SSF and MON and SSF_Reported

Performance monitoring:

The performance monitoring process shall be performed as specified in EN 300 417-1-1 [9], clauses 8.2.4 to 8.2.7 (see note).

NOTE: Whether or not performance monitoring is actually supported by a network element is determined by the presence of the element management performance monitoring functions.

- pN_DS ← aTSF or dEQ
- pF_DS ← dRDI
- pN_EBC ← Σ nN_B

5.3 P31e adaptation functions

5.3.1 P31e to P22x adaptation source P31e/P22x_A_So/i

Symbol:

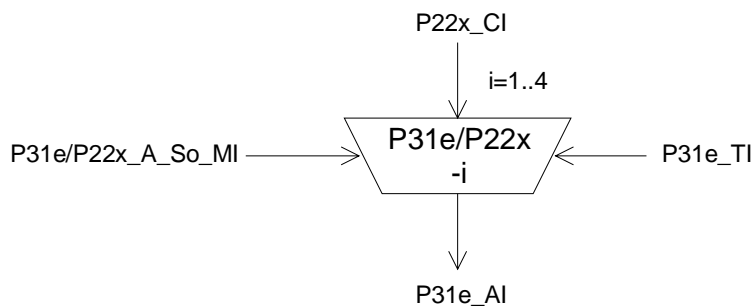

Figure 21: P31e/P22x_A_So symbol

Interfaces:

Table 13: P31e/P22x_A_So input and output signals

Input(s)	Output(s)
P22x_CI_D P22x_CI_CK P31e_TI_CK P31e_TI_FS P31e/P22x_A_So_MI_Active	P31e_AI_D P31e_AI_CK P31e_AI_FS

Processes:

This function maps one plesiochronous, 8 448 kbit/s, P22 information stream into the P31e frame (see figure 17), as specified in ITU-T Recommendation G.751 [7], clause 1.4.2. It takes P22x_CI, a bit-stream with a rate of 8 448 kbit/s \pm 30 ppm, present at its input and inserts it into the PU22 #i having a capacity of 381 bits and the justification frame as depicted in figure 18. The function can be activated/deactivated when multiple payload adaptation functions are connected to the access point.

Frequency justification and bitrate adaptation: The function shall provide for an elastic store (buffer) process. The data signal shall be written into the buffer under control of the associated input clock. The data signal shall be read out of the buffer under control of the P31e clock, frame position (P31e_TI), and justification decisions.

The justification decisions determine the phase error introduced by the P31e/P22x_A_So function. The amount of this phase error can be measured at the physical interfaces by monitoring the justification control bits C (see figure 18). An example is given in EN 300 417-4-1 [11], clause A.3.

Each justification decision results in a corresponding positive justification action. Upon a positive justification action, the reading of 1 data bit shall be cancelled once and no data are written at the justification opportunity bit J.

NOTE: A requirement for maximum introduced phase error generated by the justification process is for further study.

Buffer size: This justification process shall not introduce any errors when the input clock (P22x_CI_CK) has a frequency within the range 8 448 kbit/s \pm 30 ppm and a jitter specified by ITU-T Recommendation G.823 [8], and the P31e clock (P31e_TI_CK) has a frequency and jitter within the range specified in clause 5.5. Any step in frequency of the input clock within this range shall not cause any errors.

C bits - Justification control generation: The function shall generate the justification control (CCC) bits according the specification in ITU-T Recommendation G.751 [7]. It shall insert the justification control bits in the appropriate C bit positions.

PU-22 timeslot: The adaptation source function has access to a specific PU-22 of the P31e access point. The PU-22 is defined by the parameter i (i=1 to 4).

Activation: The function shall access the access point when it is activated (MI_Active is true). Otherwise, it shall not access the access point.

- Defects:** none.
- Consequent actions:** none.
- Defect correlations:** none.
- Performance monitoring:** none.

5.3.2 P31e to P22x adaptation sink P31e/P22x_A_Sk/i

Symbol:

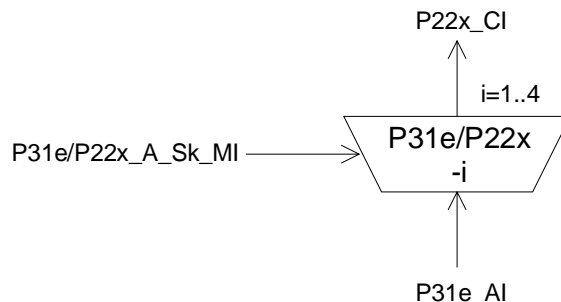

Figure 22: P31e/P22x_A_Sk symbol

Interfaces:**Table 14: P31e/P22x_A_Sk input and output signals**

Input(s)	Output(s)
P31e_AI_D	P22x_CI_D
P31e_AI_CK	P22x_CI_CK
P31e_AI_FS	P22x_CI_SSF
P31e_AI_TSF	
P31e/P22x_A_Sk_ML_Active	

Processes:

This function recovers one plesiochronous, 8 448 kbit/s, information stream P22 (see figures 17 and 18) from the P31e frame as specified in ITU-T Recommendation G.751 [7], clause 1.4.2. The function can be activated/deactivated when multiple payload adaptation functions are connected to the access point.

C bits - Justification control interpretation: The function shall perform justification control interpretation according ITU-T Recommendation G.751 [7] to recover the 8 448 kbit/s signal (P22) from the 34 368 kbit/s (P31e) payload signal. If the majority of the C bits is "0" the J bit shall be taken as a data bit, otherwise (majority of C bits is "1") J bit shall be taken as a justification bit and consequently ignored.

Smoothing process: The function shall provide for a clock smoothing and elastic store (buffer) process. The 8 448 kbit/s data signal shall be written into the store under control of the associated (gapped) input clock. The data signal shall be read out of the store under control of a smoothed (equally spaced) 8 448 kHz \pm 30 ppm clock (the rate is determined by the 8 Mbit/s signal at the input of the remote P31e/P22x_A_Sk, or P31e/P22e_A_So).

The residual jitter caused by bit justifications (measured at the 8 448 kbit/s interface) shall such that the peak-to-peak jitter at the 8 448 kbit/s output (being a tributary) in the absence of input jitter shall not exceed 0,25 UI when measured in the frequency range up to 400 kHz.

When measured with an instrument incorporating a bandpass filter having a lower cut-off frequency of 3 kHz, a roll-off of 20 dB/decade and an upper limit of 400 kHz, the peak-to-peak output jitter shall not exceed 0,05 UI with a probability of 99,9 % during a measurement period of 10 s.

Jitter transfer characteristic: A 8 448 kbit/s signal, modulated by sinusoidal jitter, applied to an adaptation source and retrieved from the adaptation sink, shall have a jitter transfer characteristic within the gain/frequency limits given in figure 23. The equivalent binary content of the test signal should be 1 000.

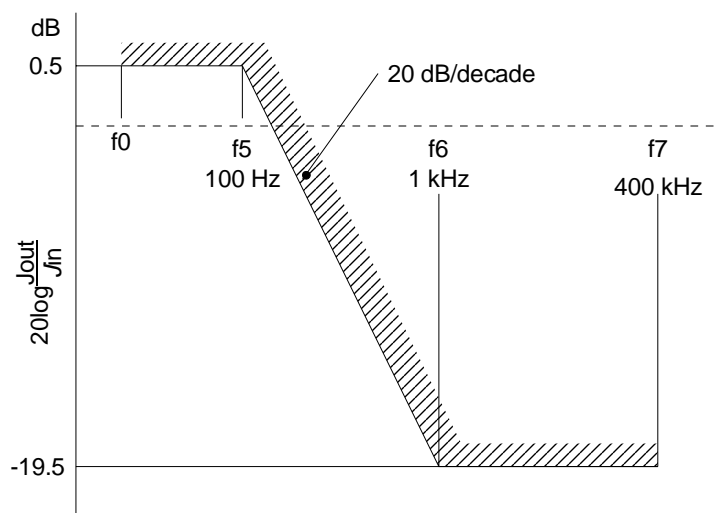

NOTE: The frequency f_0 shall be less than 20 Hz and as low as possible (e.g. 10 Hz), taking into account the limitations of measuring equipment.

Figure 23: Jitter transfer for 8 448 kbit/s signal

Buffer size: In the presence of jitter as specified in ITU-T Recommendation G.823 [8] and a frequency within the range 8 448 kbit/s ± 30 ppm, this justification process shall not introduce any errors.

Following a step in frequency of the P22x signal transported by the P31e_AI (for example due to reception of P22x CI from a new P22x_TT_So at the far end or removal of all-ONES (AIS) signal with a frequency offset) there will be a maximum recovery time of X seconds after which this process shall not generate any bit errors.

The value of X is for further study; a value of 1 second has been proposed.

PU-22 timeslot: The adaptation sink function has access to a specific PU-22 of the P31e access point. The PU-22 is defined by the parameter i (i=1 to 4).

Activation: The function shall perform the operation specified above when it is activated (MI_Active is true). Otherwise, it shall transmit the all-ONES signal at its output (CI_D) and not report its status via the management point.

Defects: none.

Consequent actions:

- aAIS ← AI_TSF
- aSSF ← AI_TSF

On declaration of aAIS the function shall output an all-ONES (AIS) signal - complying to the frequency limits for this signal (a bit rate in range 8 448 kbit/s ± 30 ppm) - within 800 µs; on clearing of aAIS the function shall output normal data within 800 µs.

Defects Correlations: none.

Performance monitoring: none.

5.3.3 P31e to P22e adaptation source P31e/P22e_A_So/i

Symbol:

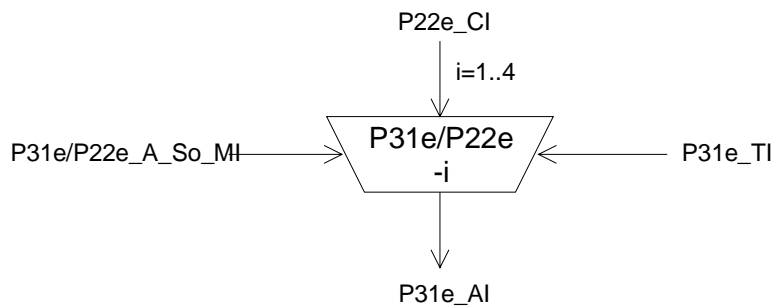

Figure 24: P31e/P22e_A_So symbol

Interfaces:

Table 15: P31e/P22e_A_So input and output signals

Input(s)	Output(s)
P22e_CI_D	P31e_AI_D
P22e_CI_CK	P31e_AI_CK
P22e_CI_FS	P31e_AI_FS
P31e_TI_CK	
P31e_TI_FS	
P31e/P22e_A_So_MI_Active	

Processes:

This function maps one plesiochronous, 8 448 kbit/s, P22 information stream into the P31e frame (see figure 17), as specified in ITU-T Recommendation G.751 [7], clause 1.4.2. It takes P22e_CI, a bit-stream with a rate of 8 448 kbit/s \pm 30 ppm, present at its input and inserts it into the PU22 #i having a capacity of 381 bits and the justification frame as depicted in figure 18. The function can be activated/deactivated when multiple payload adaptation functions are connected to the access point.

Frequency justification and bitrate adaptation: The function shall provide for an elastic store (buffer) process. The data signal shall be written into the buffer under control of the associated input clock. The data signal shall be read out of the buffer under control of the P31e clock, frame position (P31e_TI), and justification decisions.

The justification decisions determine the phase error introduced by the P31e/P22e_A_So function. The amount of this phase error can be measured at the physical interfaces by monitoring the justification control bits C (see figure 18). An example is given in EN 300 417-4-1 [11], clause A.3.

Each justification decision results in a corresponding positive justification action. Upon a positive justification action, the reading of 1 data bit shall be cancelled once and no data are written at the justification opportunity bit J.

NOTE: A requirement for maximum introduced phase error generated by the justification process is for further study.

Buffer size: This justification process shall not introduce any errors when the input clock (P22e_CI_CK) has a frequency within the range 8 448 kbit/s \pm 30 ppm and a jitter specified by ITU-T Recommendation G.823 [8], and the P31e clock (P31e_TI_CK) has a frequency and jitter within the range specified in clause 5.5. Any step in frequency of the input clock within this range shall not cause any errors.

C bits - Justification control generation: The function shall generate the justification control (CCC) bits according the specification in ITU-T Recommendation G.751 [7]. It shall insert the justification control bits in the appropriate C bit positions.

PU-22 timeslot: The adaptation source function has access to a specific PU-22 of the P31e access point. The PU-22 is defined by the parameter i (i=1 to 4).

Activation: The function shall access the access point when it is activated (MI_Active is true). Otherwise, it shall not access the access point.

Defects: none.

Consequent actions: none.

Defect correlations: none.

Performance monitoring: none.

5.3.4 P31e to P22e adaptation sink P31e/P22e_A_Sk/i

Symbol:

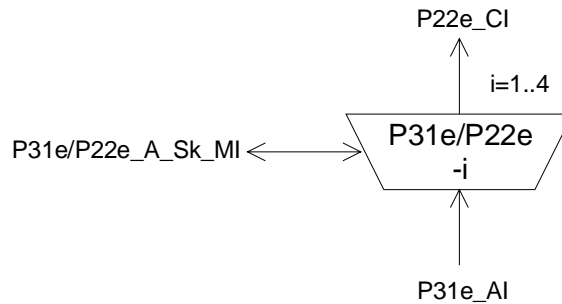

Figure 25: P31e/P22e_A_Sk symbol

Interfaces:

Table 16: P31e/P22e_A_Sk input and output signals

Input(s)	Output(s)
P31e_AI_D	P22e_CI_D
P31e_AI_CK	P22e_CI_CK
P31e_AI_FS	P22e_CI_FS
P31e_AI_TSF	P22e_CI_SSF
P31e/P22e_A_Sk_MI_Active	P31e/P22e_A_Sk_MI_cLOF
P31e/P22e_A_Sk_MI_AIS_Reported	P31e/P22e_A_Sk_MI_cAIS

Processes:

This function recovers one plesiochronous, 8 448 kbit/s, information stream P22 (see figures 17 and 18) from the P31e frame as specified in ITU-T Recommendation G.751 [7], clause 1.4.2. Further it recovers the Frame start information for the P22 tributary signal. The function can be activated/deactivated when multiple payload adaptation functions are connected to the access point.

C bits - Justification control interpretation: The function shall perform justification control interpretation according ITU-T Recommendation G.751 [7] to recover the 8 448 kbit/s signal (P22) from the 34 368 kbit/s (P31e) payload signal. If the majority of the C bits is "0" the J bit shall be taken as a data bit, otherwise (majority of C bits is "1") J bit shall be taken as a justification bit and consequently ignored.

Smoothing & jitter limiting process: The function shall provide for a clock smoothing and elastic store (buffer) process. The 8 448 kbit/s data signal shall be written into the buffer under control of the associated (gapped) input clock. The data signal shall be read out of the buffer under control of a smoothed (equally spaced) 8 448 kHz \pm 30 ppm clock (the rate is determined by the 8 Mbit/s signal at the input of the remote P31e/P22e_A_So).

The residual jitter caused by bit justifications is for further study.

Buffer size: In the presence of jitter as specified in ITU-T Recommendation G.823 [8] and a frequency within the range 8 448 kbit/s \pm 30 ppm, this justification process shall not introduce any errors.

Following a step in frequency of the P22e signal transported by the P31e_AI (for example due to reception of P22e CI from a new P22e_TT_So at the far end or removal of all-ONEs (AIS) signal with a frequency offset) there will be a maximum recovery time of X seconds after which this process shall not generate any bit errors.

The value of X is for further study; a value of 1 second has been proposed.

PU-22 timeslot: The adaptation sink function has access to a specific PU-22 of the P31e access point. The PU-22 is defined by the parameter i (i=1 to 4).

Activation: The function shall perform the operation specified above when it is activated (MI_Active is true). Otherwise, it shall transmit the all-ONEs signal at its output (CI_D) and not report its status via the management point.

Frame alignment: The function shall perform the frame alignment of the 8 448 kbit/s signal to recover the frame start signal FS. Loss of frame alignment shall be assumed to have taken place when four consecutive frame alignment signals have been incorrectly received in their predicted positions.

When frame alignment is assumed to be lost, the frame alignment device shall decide that such alignment has effectively been recovered when it detects the presence of three consecutive frame alignment signals.

The frame alignment device having detected the appearance of a single correct frame alignment signal, shall begin a new search for the frame alignment signal when it detects the absence of the frame alignment signal in one of the two following frames.

Defects:

The function shall detect a loss of frame defect (dLOF) when four consecutive frame alignment signals have been incorrectly received in their predicted positions. When frame alignment is lost, the dLOF defect shall be cleared when three consecutive frame alignment signals are detected.

The function shall detect an AIS defect (dAIS) according the specification in clause 8.2.1.7 in EN 300 417-1-1 [9], with $X = 4$, $Y = 848$, $Z = 5$.

Consequent actions:

aAIS ← dAIS or dLOF

aSSF ← dAIS or dLOF

On declaration of aAIS the function shall output an all-ONEs (AIS) signal - complying to the frequency limits for this signal (a bit rate in range 8 448 kbit/s \pm 30 ppm) - within 250 μ s; on clearing of aAIS the function shall output normal data within 250 μ s.

Defect correlations:

cAIS ← dAIS and (not AI_TSF) and AIS_Reported

cLOF ← dLOF and not dAIS

Performance monitoring: none.

5.4 P31e layer monitoring functions

5.4.1 P31e layer non-intrusive monitoring function P31em_TT_Sk

Symbol:

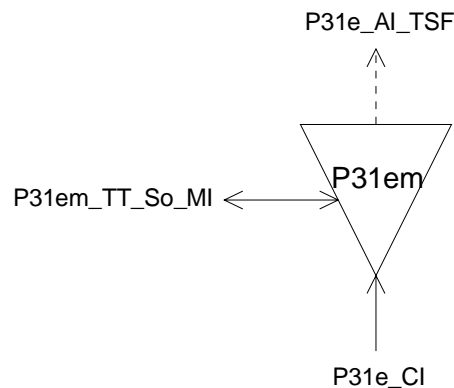

Figure 26: P31em_TT_Sk symbol

Interfaces:**Table 17: P31em_TT_Sk input and output signals**

Input(s)	Output(s)
P31e_CI_D	P31e_AI_TSF
P31e_CI_CK	P31em_TT_Sk_MI_cRDI
P31e_CI_FS	P31em_TT_Sk_MI_cSSF
P31e_CI_SSF	P31em_TT_Sk_MI_pN_DS
P31em_TT_Sk_MI_TPmode	P31em_TT_Sk_MI_pN_EBC
P31em_TT_Sk_MI_SSF_Reported	P31em_TT_Sk_MI_pF_DS
P31em_TT_Sk_MI_RDI_Reported	
P31em_TT_Sk_MI_1second	

Processes:

This function recovers the RDI information bit (see figure 17) of the frame overhead as specified in ITU-T Recommendation G.751 [7], clause 1.4.2.

RDI: The information carried in the RDI bit shall be extracted to enable single ended maintenance of a bi-directional Trail (Path). The RDI (row 3, column 3) provides information as to the status of the remote receiver. A "1" indicates a Remote Defect Indication state, while a "0" indicates the normal, working state. The application process is described in EN 300 417-1-1 [9], clauses 7.4.11 and 8.2 (RDI).

Defects:

The function shall detect for dRDI defect according the specification in EN 300 417-1-1 [9], clause 8.2.1.

Consequent actions:

aTSF ← CI_SSF

Defect correlations:

cRDI ← dRDI and MON and RDI_Reported

cSSF ← CI_SSF and MON and SSF_Reported

Performance monitoring:

The performance monitoring process shall be performed as specified in EN 300 417-1-1 [9], clauses 8.2.4 to 8.2.7 (see note).

NOTE: Whether or not performance monitoring is actually supported by a network element is determined by the presence of the element management performance monitoring functions.

A near-end block is errored (nN_B) if one or more FAS bits are errored.

pN_DS ← aTSF or dEQ

pF_DS ← dRDI

pN_EBC ← Σ nN_B

5.5 P31e PDH equipment clock adaptation source P31e_PEC

Symbol:

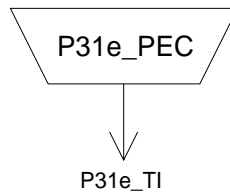

Figure 27: P31e_PEC_A_So symbol

Interfaces:

Table 18: P31e_PEC_A_So input and output signals

Input(s)	Output(s)
	P31e_TI_CK P31e_TI_FS

Processes:

This function performs the 34 Mbit/s clock and frame start signal generation to time the adaptation source functions in this layer.

Clock generation: The function shall generate the clock (bit) reference signal P31e_TI_CK for the P31e signal. The P31e_TI_CK bit rate shall be in range of 34 368 kbit/s \pm 20 ppm.

Jitter limiter: The function shall generate the clock signal such that the peak-to-peak jitter at the 34 368 kbit/s output shall not exceed 0,05 UI when it is measured within the frequency range from 100 Hz to 800 kHz.

Frame Start signal generation: The function shall generate the frame start reference signal P31e_TI_FS for the P31e signal. The P31e_TI_FS signal shall be active once per 1 536 bits.

Defects: none.

Consequent actions: none.

Defect correlations: none.

Performance monitoring: none.

6 P22e path layer functions

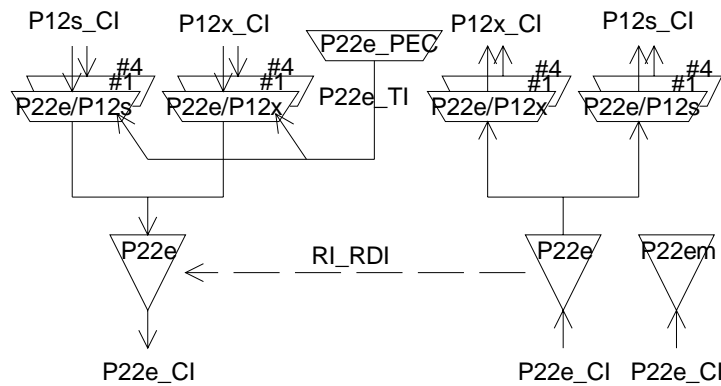

Figure 28: P22e atomic functions

P22e layer CP

The CI at this point is 8 448 kbit/s bit structured signal as specified in ITU-T Recommendation G.742 [6] with co-directional bit timing and the frame start information FS. The CI is structured to form a 848 bit long frame with 12 bit frame overhead containing 10 bit FAS, one bit RDI and one bit user CI.

NOTE 1: The bit for National Use (NU) in row 3, column 4 of figure 29 are reserved for operator specific usage. Their processing is not within the province of the present document.

P22e layer AP

The AI at this point is a multiplexed signal containing four $(209/848) \times 8\,448$ kbit/s (see note 2) tributary signals and $(1/848) \times 8\,448$ kbit/s (see note 3) User Characteristic Information (NU) with co-directional bit timing and frame start information.

NOTE 2: This equation equals a bitrate of 2 082.113 207 547 kbit/s.

NOTE 3: This equation equals a bitrate of 9.962 264 150 943 kbit/s.

The signal transported by an PU12 will be determined by the client layer application. Typical signals include:

- a 2 048 kbit/s signal P12x_CI without an assumed structure and justification overhead bits;
- a 2 048 kbit/s signal P12s_CI with a frame structure according ETS 300 167 [2] and justification overhead bits.

Figure 28 shows that more than one adaptation function exists in this P22e layer that can be connected to one P22e access point. For the case of the adaptation source functions, only one of these adaptation source functions is allowed to be activated. For this activated source, access to the access point by other adaptation source functions shall be denied. In contradiction with the source direction, adaptation sink functions may be activated all together. This may cause faults (e.g. cLOF) to be detected and reported. To prevent this an adaptation sink function can be deactivated.

NOTE 4: If one adaptation function only is connected to the AP, it will be activated. If one or more other functions are connected to the same AP, one out of the set of functions will be active.

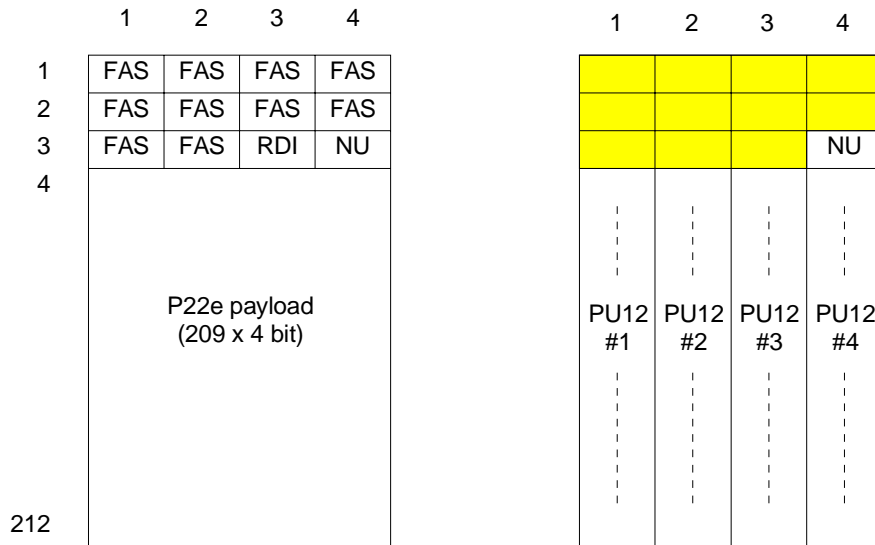

Figure 29: P22e_CI_D (left) and P22e_AI_D (right) signals

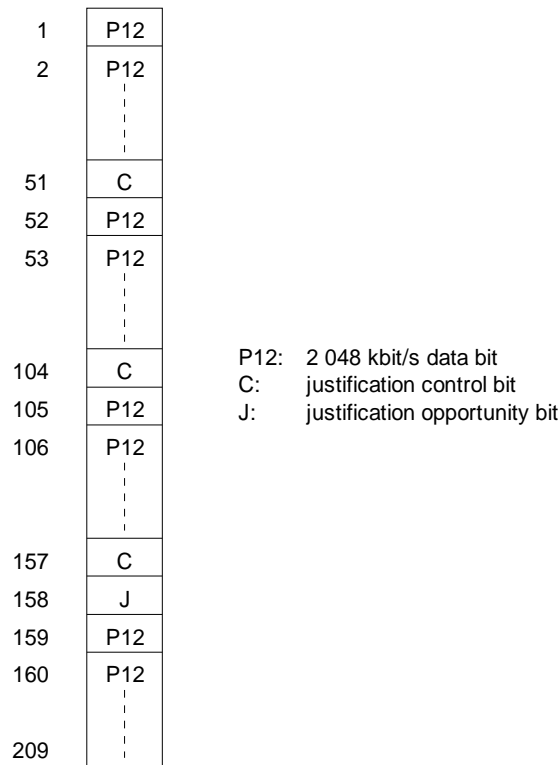

Figure 30: PU12 #i (i=1,2,3,4) of P22e_AI_D

6.1 P22e connection functions

For further study.

6.2 P22e trail termination functions

6.2.1 P22e trail termination source P22e_TT_So

Symbol:

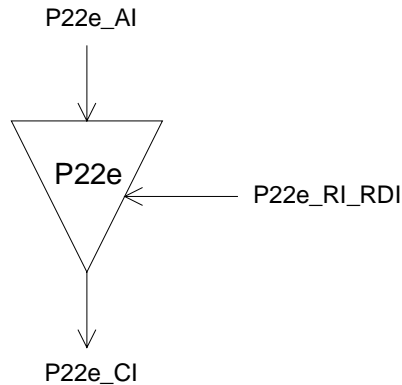

Figure 31: P22e_TT_So symbol

Interfaces:

Table 19: P22e_TT_So input and output signals

Input(s)	Output(s)
P22e_AI_D P22e_AI_CK P22e_AI_FS P22e_RI_RDI	P22e_CI_D P22e_CI_CK P22e_CI_FS

Processes:

This function adds the RDI information bit (see figure 29) and the frame alignment signal into the frame overhead. The frame overhead is defined as the first 12 bits of this frame as specified in ITU-T Recommendation G.742 [6], clause 5.

RDI: This bit represents the defect status of the associated P22e_TT_Sk. The RDI indication shall be set to "1" on activation of P22e_RI_RDI within 600 μ s, determined by the associated P22e_TT_Sk function, and set to "0" within 600 μ s on the P22e_RI_RDI removal.

Frame Alignment Signal (FAS): The function shall insert the 8 448 kbit/s frame alignment signal (1111010000) into the frame overhead.

Defects: none.

Consequent actions: none.

Defect correlations: none.

Performance monitoring: none.

6.2.2 P22e trail termination sink P22e_TT_Sk

Symbol:

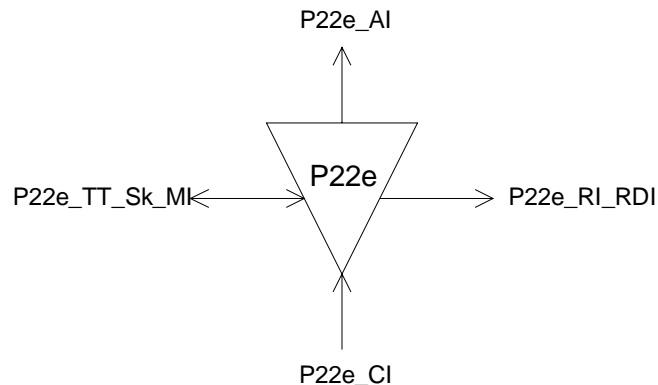

Figure 32: P22e_TT_Sk symbol

Interfaces:

Table 20: P22e_TT_Sk input and output signals

Input(s)	Output(s)
P22e_CI_D	P22e_AI_D
P22e_CI_CK	P22e_AI_CK
P22e_CI_FS	P22e_AI_FS
P22e_CI_SSF	P22e_AI_TSF
P22e_TT_Sk_MI_TPmode	P22e_RI_RDI
P22e_TT_Sk_MI_SSF_Reported	P22em_TT_Sk_MI_cRDI
P22e_TT_Sk_MI_RDI_Reported	P22em_TT_Sk_MI_cSSF
P22e_TT_Sk_MI_1second	P31e_TT_Sk_MI_pN_DS
	P31e_TT_Sk_MI_pN_EBC
	P31e_TT_Sk_MI_pF_DS

Processes:

This function recovers the RDI information bit (see figure 29) of the frame overhead as specified in ITU-T Recommendation G.742 [6], clause 5.

FAS: The FAS bits of each received frame are compared to their expected value "1111010000". A difference is taken as evidence of one or more errors (nN_B) in the block.

RDI: The information carried in the RDI bit shall be extracted to enable single ended maintenance of a bi-directional Trail (Path). The RDI (row 3, column 3) provides information as to the status of the remote receiver. A "1" indicates a Remote Defect Indication state, while a "0" indicates the normal, working state. The application process is described in EN 300 417-1-1 [9], clauses 7.4.11 and 8.2 (RDI).

Defects:

The function shall detect for dRDI defect according the specification in EN 300 417-1-1 [9], clause 8.2.1.

Consequent actions:

aTSF ← CI_SSF

aRDI ← CI_SSF

Defect correlations:

cRDI ← dRDI and MON and RDI_Reported

cSSF ← CI_SSF and MON and SSF_Reported

Performance monitoring:

The performance monitoring process shall be performed as specified in EN 300 417-1-1 [9], clauses 8.2.4 to 8.2.7 (see note).

NOTE: Whether or not performance monitoring is actually supported by a network element is determined by the presence of the element management performance monitoring functions.

pN_DS ← aTSF or dEQ

pF_DS ← dRDI

pN_EBC ← Σ nN_B

6.3 P22e adaptation functions

6.3.1 P22e to P12x adaptation source P22e/P12x_A_So/i

Symbol:

Figure 33: P22e/P12x_A_So symbol

Interfaces:

Table 21: P22e/P12x_A_So input and output signals

Input(s)	Output(s)
P12x_CI_D P12x_CI_CK P22e_TI_CK P22e_TI_FS P22e/P12x_A_So_MI_Active	P22e_AI_D P22e_AI_CK P22e_AI_FS

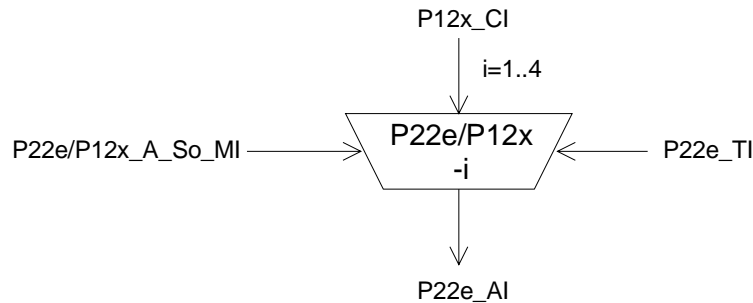
Processes:

This function maps one plesiochronous, 2 048 kbit/s, P12 information stream into the P22e frame (see figure 29), as specified in ITU-T Recommendation G.742 [6], clause 5. It takes P12x_CI, a bit-stream with a rate of 2 048 kbit/s \pm 50 ppm, present at its input and inserts it into the PU12 #i having a capacity of 209 bits and the justification frame as depicted in figure 30. The function can be activated/deactivated when multiple payload adaptation functions are connected to the access point.

Frequency justification and bitrate adaptation: The function shall provide for an elastic store (buffer) process. The data signal shall be written into the buffer under control of the associated input clock. The data signal shall be read out of the buffer under control of the P22e clock, frame position (P22e_TI), and justification decisions.

The justification decisions determine the phase error introduced by the P22e/P12x_A_So function. The amount of this phase error can be measured at the physical interfaces by monitoring the justification control bits C (see figure 30). An example is given in EN 300 417-4-1 [11], clause A.3.

Each justification decision results in a corresponding positive justification action. Upon a positive justification action, the reading of 1 data bit shall be cancelled once and no data are written at the justification opportunity bit J.

NOTE: A requirement for maximum introduced phase error generated by the justification process is for further study.

Buffer size: In the presence of jitter specified by ITU-T Recommendation G.823 [8] and a frequency within the range 2 048 kbit/s \pm 50 ppm, this justification process shall not introduce any errors. Any step in frequency within this range shall not cause any errors.

Buffer size: This justification process shall not introduce any errors when the input clock (P12x_CI_CK) has a frequency within the range 2 048 kbit/s \pm 50 ppm and a jitter specified by ITU-T Recommendation G.823 [8], and the P22e clock (P22e_TI_CK) has a frequency and jitter within the range specified in clause 5.5. Any step in frequency of the input clock within this range shall not cause any errors.

C bits - Justification control generation: The function shall generate the justification control (CCC) bits according to the specification in ITU-T Recommendation G.742 [6]. It shall insert the justification control bits in the appropriate C bit positions.

PU-12 timeslot: The adaptation source function has access to a specific PU-12 of the P22e access point. The PU-12 is defined by the parameter i (i=1 to 4).

Activation: The function shall access the access point when it is activated (MI_Active is true). Otherwise, it shall not access the access point.

Defects: none.

Consequent actions: none.

Defect correlations: none.

Performance monitoring: none.

6.3.2 P22e to P12x adaptation sink P22e/P12x_A_Sk/i

Symbol:

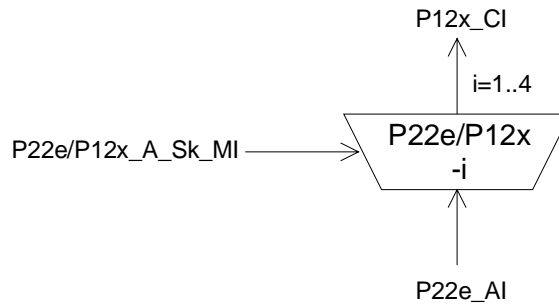

Figure 34: P22e/P12x_A_Sk symbol

Interfaces:

Table 22: P22e/P12x_A_Sk input and output signals

Input(s)	Output(s)
P22e_AI_D	P12x_CI_D
P22e_AI_CK	P12x_CI_CK
P22e_AI_FS	P12x_CI_SSF
P22e_AI_TSF	
P22e/P12x_A_Sk_MI_Active	

Processes:

This function recovers one plesiochronous, 2 048 kbit/s, information stream P12 (see figures 29 and 30) from the P22e frame as specified in ITU-T Recommendation G.742 [6], clause 5. The function can be activated/deactivated when multiple payload adaptation functions are connected to the access point.

C bits - Justification control interpretation: The function shall perform justification control interpretation as specified in ITU-T Recommendation G.742 [6] to recover the 2 048 kbit/s signal (P12) from the 8 448 kbit/s (P22e) payload signal. If the majority of the C bits is "0" the J bit shall be taken as a data bit, otherwise (majority of C bits is "1") J bit shall be taken as a justification bit and consequently ignored.

Smoothing and jitter limiting process: The function shall provide for a clock smoothing and elastic store (buffer) process. The 2 048 kbit/s data signal shall be written into the store under control of the associated (gapped) input clock. The data signal shall be read out of the store under control of a smoothed (equally spaced) 2 048 kHz \pm 50 ppm clock (the rate is determined by the 2 Mbit/s signal at the input of the remote P22e/P12x_A_Sk, or P22e/P12s_A_So).

The residual jitter caused by bit justifications (measured at the 2 048 kbit/s interface) shall such that the peak-to-peak jitter at the 2 048 kbit/s output (being a tributary) in the absence of input jitter shall not exceed 0,25 UI when measured in the frequency range up to 100 kHz.

When measured with an instrument incorporating a bandpass filter having a lower cut-off frequency of 18 kHz, a roll-off of 20 dB/decade and an upper limit of 100 kHz, the peak-to-peak output jitter shall not exceed 0,05 UI with a probability of 99,9 % during a measurement period of 10 s.

NOTE: For interfaces meeting the national high Q option, detailed in ITU-T Recommendation G.703 [3], the lower cut-off frequency for the above measurement should be 700 Hz.

Jitter transfer characteristic: A 2 048 kbit/s signal, modulated by sinusoidal jitter, applied to an adaptation source and retrieved from the adaptation sink, shall have a jitter transfer characteristic within the gain/frequency limits given in figure 35. The equivalent binary content of the test signal should be 1 000.

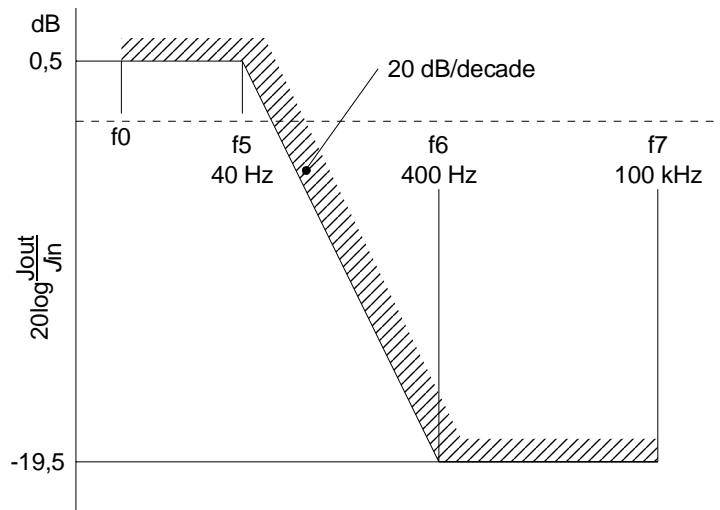

NOTE: The frequency f_0 shall be less than 20 Hz and as low as possible (e.g. 10 Hz), taking into account the limitations of measuring equipment.

Figure 35: Jitter transfer for 2048 kbit/s signal

Buffer size: In the presence of jitter as specified in ITU-T Recommendation G.823 [8] and a frequency within the range 2 048 kbit/s \pm 50 ppm, this justification process shall not introduce any errors.

Following a step in frequency of the P12x signal transported by the P22e_AI (for example due to reception of P12x CI from a new P12x_TT_So at the far end or removal of all-ONEs (AIS) signal with a frequency offset) there will be a maximum recovery time of X seconds after which this process shall not generate any bit errors.

The value of X is for further study; a value of 1 second has been proposed.

PU-12 timeslot: The adaptation sink function has access to a specific PU-12 of the P22e access point. The PU-12 is defined by the parameter i ($i=1$ to 4).

Activation: The function shall perform the operation specified above when it is activated (MI_Active is true). Otherwise, it shall transmit the all-ONEs signal at its output (CI_D) and not report its status via the management point.

Defects: none.

Consequent actions:

aAIS \leftarrow AI_TSF

aSSF \leftarrow AI_TSF

On declaration of aAIS the function shall output an all-ONEs (AIS) signal - complying to the frequency limits for this signal (a bit rate in range 2 048 kbit/s \pm 50 ppm) - within 600 μ s; on clearing of aAIS the function shall output normal data within 600 μ s.

Defects Correlations: none.

Performance monitoring: none.

6.3.3 P22e to P12s adaptation source P22e/P12s_A_So/i

Symbol:

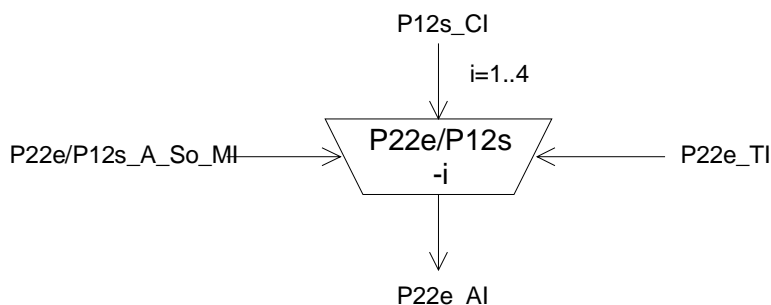

Figure 36: P22e/P12s_A_So symbol

Interfaces:

Table 23: P22e/P12s_A_So input and output signals

Input(s)	Output(s)
P12s_CI_D	P22e_AI_D
P12s_CI_CK	P22e_AI_CK
P22e_TI_CK	P22e_AI_FS
P22e_TI_FS	
P22e/P12s_A_So_MI_Active	

Processes:

This function maps one synchronous, 2 048 kbit/s, P12s information stream into the P22e frame (see figure 29), as specified in ITU-T Recommendation G.742 [6], clause 5. It takes P12s_CI, a bit-stream with a rate of 2 048 kbit/s \pm 50 ppm (see note 1), present at its input and inserts it into the PU12 #i having a capacity of 209 bits and the justification frame as depicted in figure 30. The function can be activated/deactivated when multiple payload adaptation functions are connected to the access point.

NOTE 1: The 2 048 kbit/s with a 125 μ s frame as specified in ETS 300 167 [2] is nominally locked to a PRC.

Frequency justification and bitrate adaptation: The function shall provide for an elastic store (buffer) process. The data signal shall be written into the buffer under control of the associated input clock. The data signal shall be read out of the buffer under control of the P22e clock, frame position (P22e_TI), and justification decisions.

The justification decisions determine the phase error introduced by the P22e/P12s_A_So function. The amount of this phase error can be measured at the physical interfaces by monitoring the justification control bits C (see figure 30). An example is given in EN 300 417-4-1 [11], clause A.3.

Each justification decision results in a corresponding positive justification action. Upon a positive justification action, the reading of 1 data bit shall be cancelled once and no data are written at the justification opportunity bit J.

NOTE 2: A requirement for maximum introduced phase error generated by the justification process is for further study.

Buffer size: This justification process shall not introduce any errors when the input clock (P12s_CI_CK) has a frequency within the range 2 048 kbit/s \pm 50 ppm and a jitter specified by ITU-T Recommendation G.823 [8], and the P22e clock (P22e_TI_CK) has a frequency and jitter within the range specified in clause 5.5. Any step in frequency of the input clock within this range shall not cause any errors.

C bits - Justification control generation: The function shall generate the justification control (C) bits according the specification in ITU-T Recommendation G.742 [6]. It shall insert the justification control bits in the appropriate C bit positions.

PU-12 timeslot: The adaptation source function has access to a specific PU-12 of the P22e access point. The PU-12 is defined by the parameter i ($i=1$ to 4).

Activation: The function shall access the access point when it is activated (MI_Active is true). Otherwise, it shall not access the access point.

Defects: none.

Consequent actions: none.

Defect correlations: none.

Performance monitoring: none.

6.3.4 P22e to P12s adaptation sink P22e/P12s_A_Sk/i

Symbol:

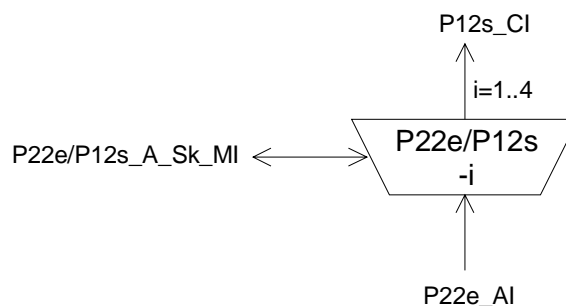

Figure 37: P22e/P12s_A_Sk symbol

Interfaces:

Table 24: P22e/P12s_A_Sk input and output signals

Input(s)	Output(s)
P22e_AI_D	P12s_CI_D
P22e_AI_CK	P12s_CI_CK
P22e_AI_FS	P12s_CI_SSF
P22e_AI_TSF	P12s_CI_FS
P22e/P12s_A_Sk_MI_Active	P12s_CI_MFS
P22e/P12s_A_Sk_MI_AIS_Reported	P12s_CI_MFP
P22e/P12s_A_Sk_MI_CRC4mode	P22e/P12s_A_Sk_MI_cLOF
	P22e/P12s_A_Sk_MI_cAIS
	P22e/P12s_A_Sk_MI_NCI

Processes:

This function recovers one synchronous, 2 048 kbit/s, information stream P12s (see figures 29 and 30) from the P22e frame as specified in ITU-T Recommendation G.742 [6], clause 5. Further it recovers the frame start information for the P12s tributary signal. The function can be activated/deactivated when multiple payload adaptation functions are connected to the access point. It supplies the recovered timing signal to the synchronization distribution layer.

C bits - Justification control interpretation: The function shall perform justification control interpretation as specified in ITU-T Recommendation G.742 [6] to recover the 2 048 kbit/s signal (P12) from the 8 448 kbit/s (P22e) payload signal. If the majority of the C bits is "0" the J bit shall be taken as a data bit, otherwise (majority of C bits is "1") J bit shall be taken as a justification bit and consequently ignored.

Smoothing and jitter limiting process: The function shall provide for a clock smoothing and elastic store (buffer) process. The 2 048 kbit/s data signal shall be written into the store under control of the associated (gapped) input clock. The data signal shall be read out of the store under control of a smoothed (equally spaced) 2 048 kHz \pm 50 ppm clock (the rate is determined by the 2 Mbit/s signal at the input of the remote P22e/P12s_A_Sk).

NOTE 1: The P12s signal is nominally locked to a PRC. Under fault conditions however, the P12s signal is replaced by an all-ONEs (AIS) signal with 50 ppm frequency tolerance.

The residual jitter caused by bit justifications is for further study.

NOTE 2: For interfaces meeting the national high Q option, detailed in ITU-T Recommendation G.703 [3], the lower cut-off frequency for the above should be 700 Hz.

Buffer size: In the presence of jitter as specified in ITU-T Recommendation G.823 [8] and a frequency within the range $2\,048\text{ kbit/s} \pm 50\text{ ppm}$, this justification process shall not introduce any errors.

Following a step in frequency of the P12s signal transported by the P22e_AI (for example due to reception of P12s CI from a new P12s_TT_So at the far end or removal of all-ONEs (AIS) signal with a frequency offset) there will be a maximum recovery time of X seconds after which this process shall not generate any bit errors.

The value of X is for further study; a value of 1 second has been proposed.

PU-12 timeslot: The adaptation sink function has access to a specific PU-12 of the P22e access point. The PU-12 is defined by the parameter i (i=1 to 4).

Activation: The function shall perform the operation specified above when it is activated (MI_Active is true). Otherwise, it shall transmit the all-ONEs signal at its output (CI_D) and not report its status via the management point.

Basic frame and CRC-4 Multiframe alignment: The function shall recover the (250 μ s) basic frame and (2 ms) CRC-4 multiframe phase. The process shall operate as specified by ITU-T Recommendation G.706 [5]. Either the manual, or the automatic, or both manual and automatic interworking modes shall be supported.

NOTE 3: The frame alignment process in ITU-T Recommendation G.706 [5] is under study.

The process shall generate a multiframe present signal (CI_MFP) according to the following rules:

- CI_MFP shall be FALSE when the CRC4mode is OFF;
- CI_MFP shall be FALSE when the CRC4mode is ON and the frame alignment process has not yet found multiframe alignment. CI_MFP shall be TRUE when multiframe alignment has been found;
- CI_MFP shall be FALSE when the CRC4mode is AUTO and the frame alignment process is in the states out-of-primary-BFA, in-primary-BFA, CRC-4 MFA search, assume-crc-to-non-crc-interworking. CI_MFP shall be TRUE if the frame alignment process is in the state assume-crc-to-crc-interworking.

Defects:

The function shall detect dLOF defect as specified by ITU-T Recommendation G.706 [5].

The function shall clear dLOF defect as specified by ITU-T Recommendation G.706 [5].

The function shall report NCI status in the automatic CRC-4 interworking mode as specified by ITU-T Recommendation G.706 [5].

The dAIS defect shall be detected as defined in EN 300 417-1-1 [9], clause 8.2.1.7 for 2 Mbit/s, with X = 2, Y = 512, Z = 3.

Consequent actions:

aAIS ← dAIS or dLOF

aSSF ← dAIS or dLOF

On declaration of aAIS the function shall output an all-ONEs (AIS) signal - complying to the frequency limits for this signal (a bit rate in range $2048\text{ kbit/s} \pm 50\text{ ppm}$) - within 500 μ s; on clearing of aAIS the function shall output normal data within 500 μ s.

Defect correlations:

cAIS ← dAIS and (not AI_TSF) and AIS_Reported

cLOF ← dLOF and (not dAIS) and (not AI_TSF)

Performance monitoring: none.

6.4 P22e layer monitoring functions

6.4.1 P22e layer non-intrusive monitoring function P22em_TT_Sk

Symbol:

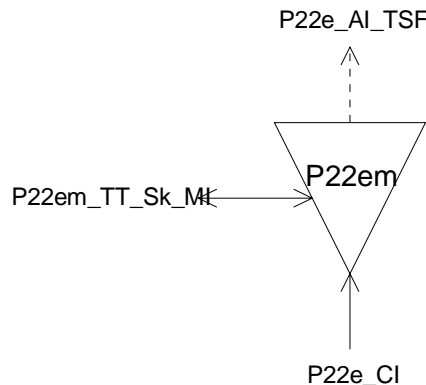

Figure 38: P22em_TT_Sk symbol

Interfaces:

Table 25: P22em_TT_Sk input and output signals

Input(s)	Output(s)
P22e_CI_D	P22e_AI_TSF
P22e_CI_CK	P22em_TT_Sk_MI_cRDI
P22e_CI_FS	P22em_TT_Sk_MI_cSSF
P22e_CI_SSF	P22em_TT_Sk_MI_pN_DS
P22em_TT_Sk_MI_TPmode	P22em_TT_Sk_MI_pN_EBC
P22em_TT_Sk_MI_SSF_Reported	P22em_TT_Sk_MI_pF_DS
P22em_TT_Sk_MI_RDI_Reported	
P22em_TT_Sk_MI_1second	

Processes:

This function recovers the RDI information bit (see figure 29) of the frame overhead as specified in ITU-T Recommendation G.742 [6], clause 5.

RDI: The information carried in the RDI bit shall be extracted to enable single ended maintenance of a bi-directional Trail (Path). The RDI (row 3, column 3) provides information as to the status of the remote receiver. A "1" indicates an RDI state, while a "0" indicates the normal, working state. The application process is described in EN 300 417-1-1 [9], clauses 7.4.11 and 8.2 (RDI).

Defects:

The function shall detect for dRDI defect according the specification in EN 300 417-1-1 [9], clause 8.2.1.

Consequent actions:

aTSF ← CI_SSF

Defect correlations:

cRDI ← dRDI and MON and RDI_Reported

cSSF ← CI_SSF and MON and SSF_Reported

Performance monitoring:

The performance monitoring process shall be performed as specified in EN 300 417-1-1 [9], clauses 8.2.4 to 8.2.7 (see note).

NOTE: Whether or not performance monitoring is actually supported by a network element is determined by the presence of the element management performance monitoring functions.

A near-end block is errored (nN_B) if one or more FAS bits are errored.

pN_DS ← aTSF or dEQ

pF_DS ← dRDI

pN_EBC ← Σ nN_B

6.5 P22e PDH equipment clock adaptation source P22e_PEC

Symbol:

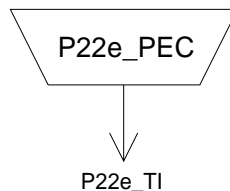

Figure 39: P22e_PEC_A_So symbol

Interfaces:

Table 26: P22e_PEC_A_So input and output signals

Input(s)	Output(s)
	P22e_TI_CK P22e_TI_FS

Processes:

This function performs the 8 Mbit/s clock and frame start signal generation to time the adaptation source functions in this layer.

Clock generation: The function shall generate the clock (bit) reference signal P22e_TI_CK for the P22e signal. The P22e_TI_CK bit rate shall be in range of 8 448 kbit/s \pm 30 ppm.

Jitter limiter: The function shall generate the clock signal such that the peak-to-peak jitter at the 8 448 kbit/s output shall not exceed 0,05 UI when it is measured within the frequency range from 20 Hz to 400 kHz.

Frame Start signal generation: The function shall generate the frame start reference signal P22e_TI_FS for the P22e signal. The P22e_TI_FS signal shall be active once per 848 bits.

Defects: none.

Consequent actions: none.

Defect correlations: none.

Performance monitoring: none.

7 P12s path layer functions

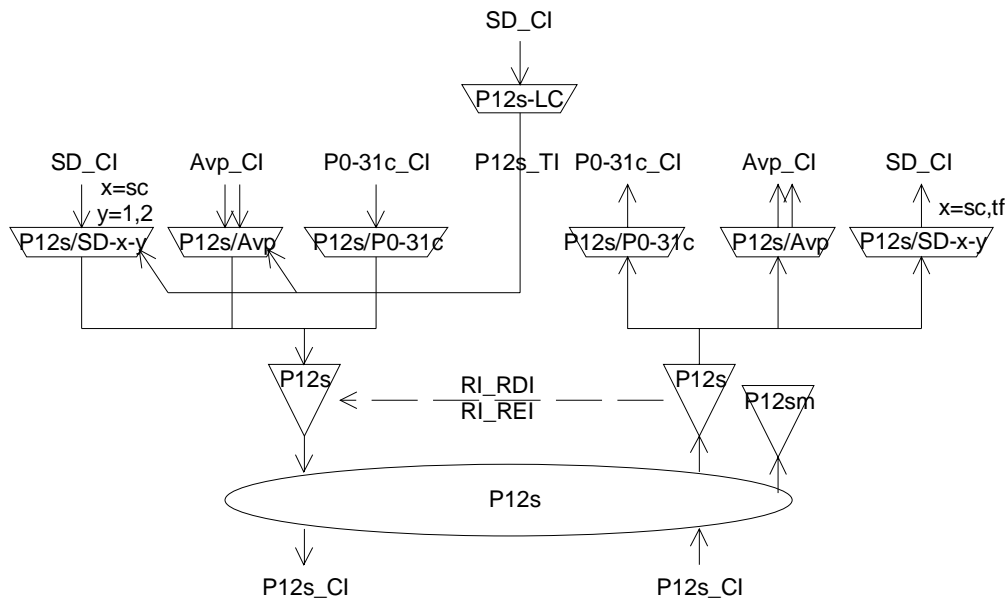

Figure 40: P12s Atomic Functions

P12s layer CP

The CI at this point is a synchronous 2 048 kbit/s byte structured signal as specified in ETS 300 167 [2] with co-directional bit timing and the frame start information FS. The CI is structured:

- either as a 2×256 bit long (basic) frame with 2×8 bit frame overhead containing a FAS, RDI (A bit), and User Characteristic Information (S_i and S_a bits);
- or as a 16×256 bit long (multi) frame with 16×8 bit frame overhead containing a FAS, CRC-4 MFAS, CRC-4 code, RDI (A bit), REI (E bits), User characteristic information (S_a bits), and (optionally) a Synchronization Status Message channel.

Figures 41 and 43 depict the basic frame, multiframe and overhead structure.

P12s layer AP

The signal transported by a P12s will be determined by the client layer application. Typical signals include:

- a 1 984 kbit/s signal P0-31c_CI with unspecified content (to be passed through transparently);
- an ATM 1 920 kbit/s cell stream signal as specified in ETS 300 337 [10].

NOTE: Many more compositions exist which are not addressed in this version of the present document.

In addition, the AI may contain:

- a 4 bit Synchronization Status Message (SSM), located in one of the five S_a bits. This interface is used to pass timing synchronization information.

Figure 40 shows that more than one adaptation function exists in this P12s layer that can be connected to one P12s access point. For the case of the adaptation source functions, only one of these adaptation source functions is allowed to be activated. For this activated source, access to the access point by other adaptation source functions shall be denied. In contradiction with the source direction, adaptation sink functions may be activated all together. This may cause faults (e.g. cLOF) to be detected and reported. To prevent this an adaptation sink function can be deactivated.

NOTE 2: If one adaptation function only is connected to the AP, it will be activated. If one or more other functions are connected to the same AP, one out of the set of functions will be active.

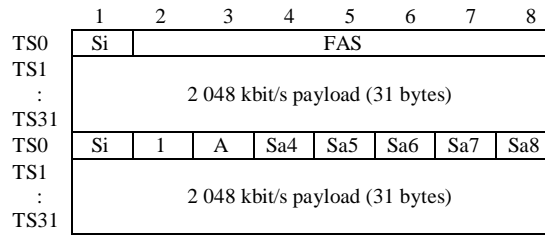

Figure 41: Basic frame overhead structure of the P12s_CI_D signal

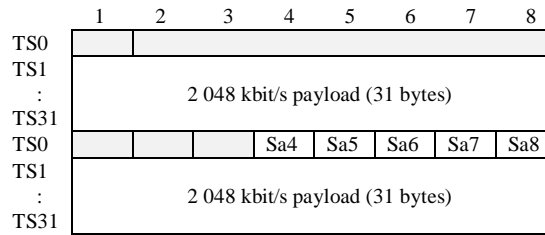

Figure 42: Basic frame overhead structure of the P12s_AI_D signal

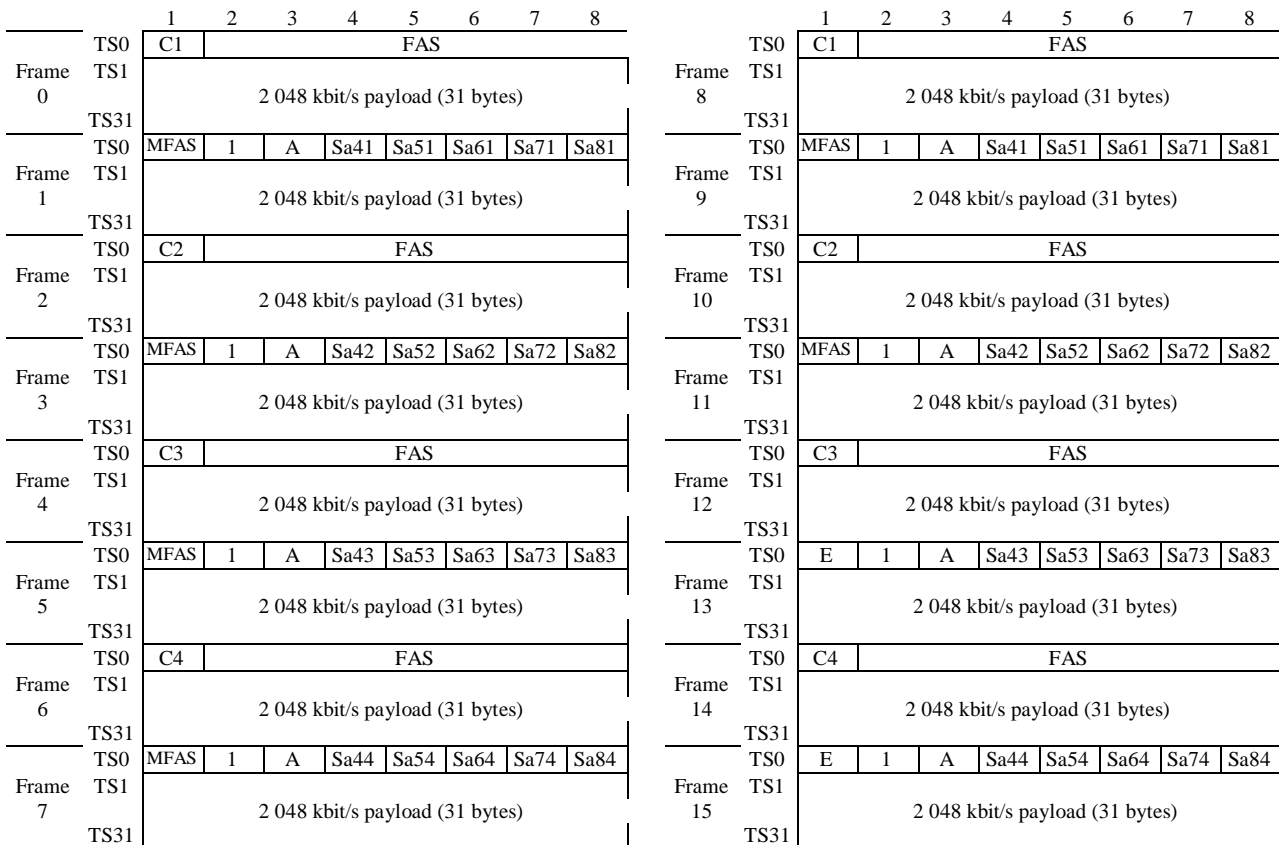

Figure 43: CRC-4 multiframe structure of the P12s_CI_D signal (with 4 bit code Sa structure)

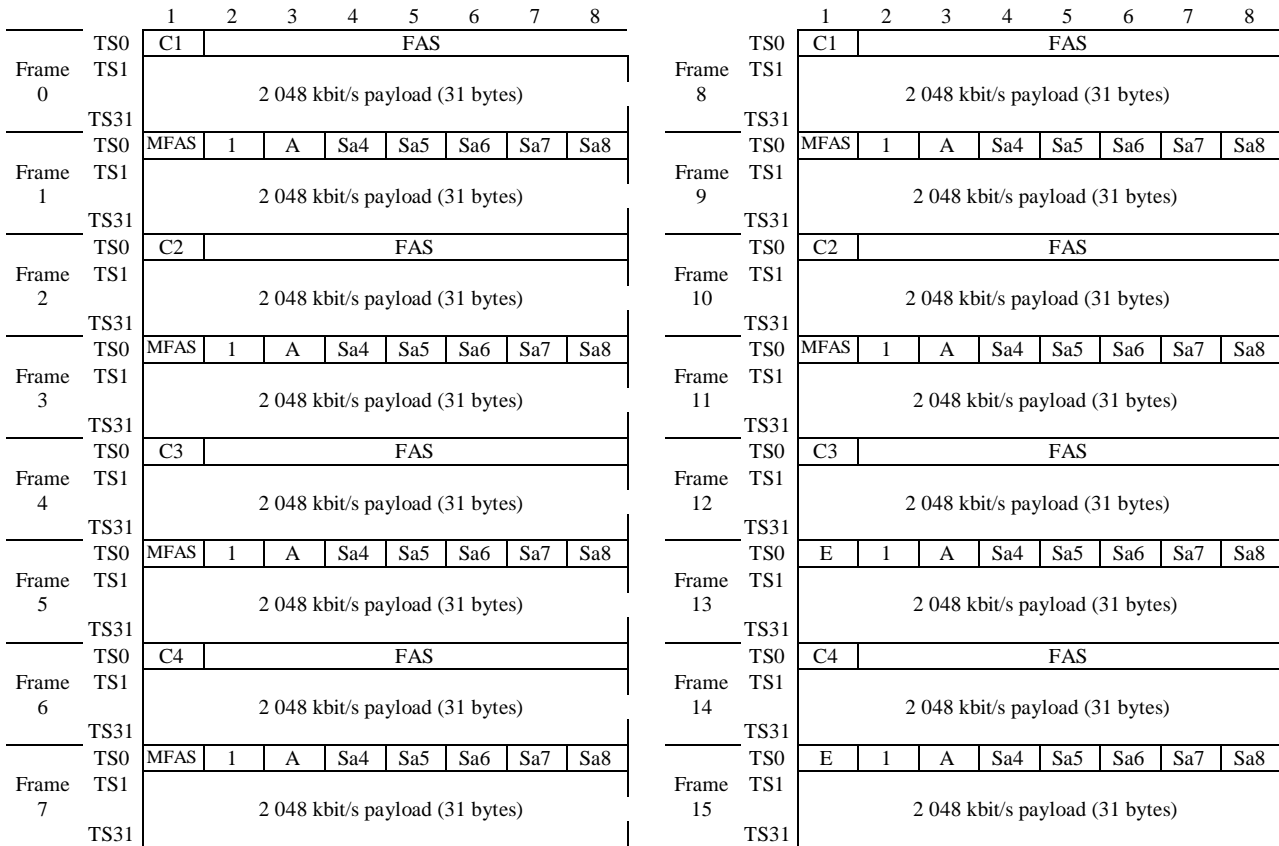

Figure 44: CRC-4 multiframe structure of the P12s_CI_D signal (without 4 bit code Sa structure)

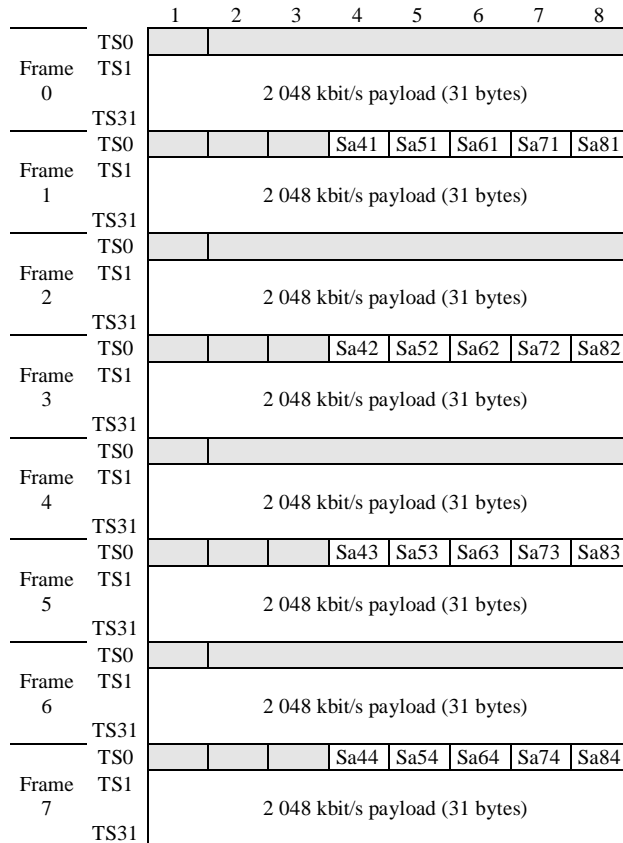

Figure 45: 4 bit S_{ax} structure in "CRC-4 submultiframe" of the P12s_AI_D signal

7.1 P12s connection functions

For further study.

7.2 P12s trail termination functions

7.2.1 P12s trail termination source P12s_TT_So

Symbol:

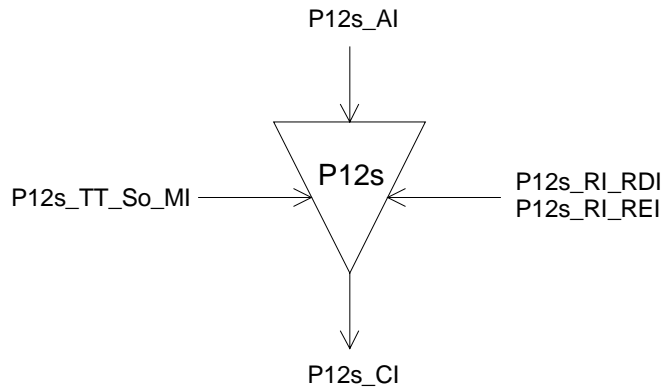

Figure 46: P12s_TT_So symbol

Interfaces:

Table 27: P12s_TT_So input and output signals

Input(s)	Output(s)
P12s_AI_D	P12s_CI_D
P12s_AI_CK	P12s_CI_CK
P12s_AI_FS	P12s_CI_FS
P12s_AI_MFS	
P12s_AI_AISinsert	
P12s_RI_RDI	
P12s_RI_REI	
P12s_TT_So_MI_CRC4mode	

Processes:

This function adds to P12s_AI the RDI information bit (see figures 41 and 43), the frame alignment signal, the CRC-4 multiframe alignment signal, the CRC-4 code, and REI information into the frame overhead. The frame overhead is defined in ETS 300 167 [2].

A: This bit represents the defect status of the associated P12s_TT_Sk. The RDI indication shall be set to "1" on activation of P12s_RI_RDI within 5 ms, determined by the associated P12s_TT_Sk function, and set to "0" within 5 ms on the P12s_RI_RDI removal.

NOTE 1: Components in "old" and "new" equipment designed prior to the present document may meet 100 ms or less, instead of 5 ms. For some applications where this delay is not critical, a maximum value of 100 ms may be acceptable.

FAS - Frame Alignment Signal (FAS): The function shall insert the 2 048 kbit/s frame alignment signal "0011011" in bits 2 to 8 of TS0 in even frames, and "1" in bit 2 of TS0 in odd frames as defined in ETS 300 167 [2].

S_i - TimeSlot 0, bit 1: If CRC4mode is OFF, the function shall insert "1" into bit 1 of TimeSlot 0. If CRC4mode is ON or AUTO, the function shall generate the CRC-4 multiframe and perform the MFAS, E bit and C₁C₂C₃C₄ processes as defined:

NOTE 2: P12s_TT_So_MI_CRC4mode signal shall be the same signal as the one used in the associated adaptation sink function (<server>/P12s_A_Sk) to comply with ITU-T Recommendation G.704 [4].

S_i - MFAS - CRC-4 Multiframe Alignment Signal: The function shall insert the CRC-4 multiframe alignment signal "001011" in bit 1 of TS0 in frames 1,3,5,7,9,11 of the 16 frame CRC-4 multiframe as defined in ETS 300 167 [2].

S_i - E: Two E-bits are generated for each CRC-4 multiframe. Any E bit shall be set to "1", unless RI_REI (from the associated P12s_TT_Sk function) is true. For each RI_REI value which is TRUE, one of the E-bits shall be set to "0" within 1 second after RI_REI reception.

S_i - C₁C₂C₃C₄: The function shall compute the CRC-4 code value of the 2 Mbit/s signal as specified in clause 2.3.3.5 in ITU-T Recommendation G.704 [4]. The computed value shall be inserted in the C₁ to C₄ bits of the following SubMultiFrame.

Defects: none.

Consequent actions:

aAIS ← AI_AISinsert

On activation of aAIS the function shall output an all-ONEs (AIS) signal, within the frequency range of 2 048 kbit/s ± 50 ppm, within 250 μs; on deactivation of aAIS the function shall output normal data within 250 μs.

NOTE 3: If AI_AISinsert is not connected, AI_AISinsert is assumed to be inactive, and all-ONEs (AIS) will not be output.

NOTE 4: A 2 Mbit/s E12 interface may be used to pass timing synchronization information. If the signal does not support the Synchronization Status Message (SSM) it should be shutdown (i.e. all-ONEs (AIS) insertion) when the synchronization timing source has a quality level less or equal than a minimum provisioned level. The function P12s/SD_A_So is used to control AIS injection via the AI_AISinsert signal if required. The full specification is contained in EN 300 417-6-1 [12].

Defect correlations: none.

Performance monitoring: none.

7.2.2 P12s trail termination sink P12s_TT_Sk

Symbol:

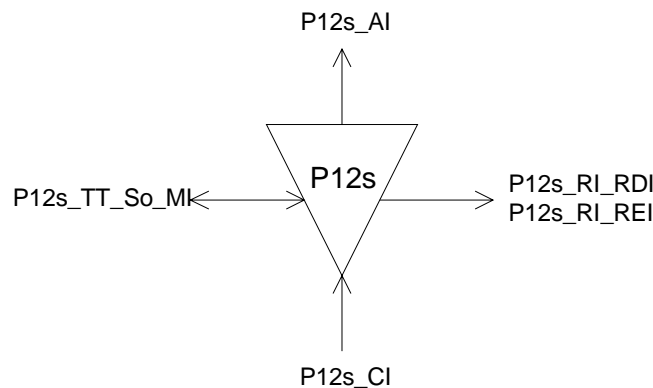

Figure 47: P12s_TT_Sk symbol

Interfaces:**Table 28: P12s_TT_Sk input and output signals**

Input(s)	Output(s)
P12s_CI_D	P12s_AI_D
P12s_CI_CK	P12s_AI_CK
P12s_CI_FS	P12s_AI_FS
P12s_CI_MFS	P12s_AI_MFS
P12s_CI_SSF	P12s_AI_TSF
P12s_CI_MFP	P12s_AI_TSD
	P12s_AI_MFP
P12s_TT_Sk_MI_TPmode	P12s_RI_RDI
P12s_TT_Sk_MI_SSF_Reported	P12s_RI_REI
P12s_TT_Sk_MI_RDI_Reported	P12s_TT_Sk_MI_cSSF
P12s_TT_Sk_MI_DEGM	P12s_TT_Sk_MI_cDEG
P12s_TT_Sk_MI_DEGTHR	P12s_TT_Sk_MI_cRDI
P12s_TT_Sk_MI_1second	P12s_TT_Sk_MI_RNCI
P12s_TT_Sk_MI_CRC4mode	P12s_TT_Sk_MI_MFP
	P12s_TT_Sk_MI_pN_EBC
	P12s_TT_Sk_MI_pN_DS
	P12s_TT_Sk_MI_pF_EBC
	P12s_TT_Sk_MI_pF_DS

Processes:

This function monitors a P12s for errors, and recovers the trail termination status. It extracts the payload independent overhead bits ($C_1C_2C_3C_4$, A, E) from the P12s layer CI and outputs the P12s_AI.

FAS: The FAS bits of each received double frame are compared to their expected value "0011011". If CI_MFP is FALSE, a difference is taken as evidence of one or more errors (nN_B) in the block.

$C_1C_2C_3C_4$: If CI_MFP is TRUE, CRC-4 is computed for each bit of the preceding P12s submultiframe and compared with bits $C_1C_2C_3C_4$ recovered from the current submultiframe. A difference between the computed and recovered $C_1C_2C_3C_4$ values is taken as evidence of one or more errors (nN_B) in the computation block.

A, E: The information carried in the A and E bits (RDI, REI) is extracted to enable single ended maintenance of a bi-directional Trail (Path). The REI is used to monitor the error performance of the other direction of transmission, and the RDI provides information as to the status of the remote receiver. An A-bit set to "1" indicates an RDI state, while a "0" indicates the normal, working state. If CI_MFP is FALSE, nF_B is set to 0. If CI_MFP is true, each E-bit set to "0" is an indication for nF_B. The application process is described in EN 300 417-1-1 [9], clauses 7.4.2 (REI), 7.4.11 and 8.2 (RDI).

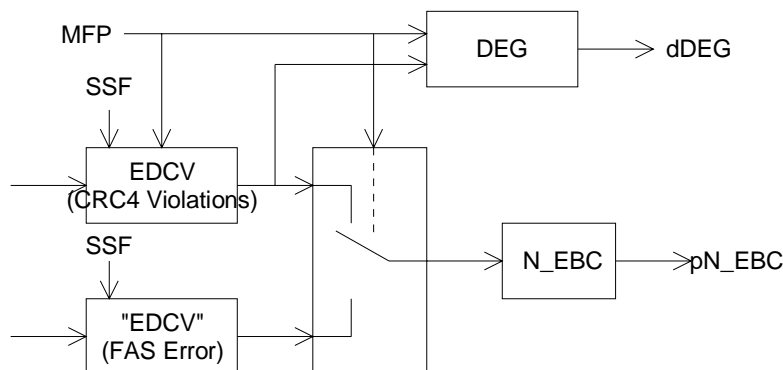
**Figure 48: dDEG and pN_EBC processing related to CI_MFP****Defects:**

The function shall detect for dRDI defect according to the specification in EN 300 417-1-1 [9], clause 8.2.1.

The function shall detect for dDEG defect as specified in EN 300 417-1-1 [9] with the following extensions (see figure 48): the Error Detection Code Violation (EDCV) process shall assume "zero" EDCVs in the incoming signal if CI_MFP is FALSE, and dDEG shall be cleared when CI_MFP is FALSE.

NOTE 1: The precise behaviour of the N_EBC counting during the second of the switch over in which MFP changes its value, is not defined in the present document.

The function shall detect a CRC-4 multiframe generator/detector status (MI_RNCI) if (pF_EBC > 990 and pF_DS = false) for five consecutive seconds. The MI_RNCI status shall be cleared if (pF_EBC < 990 or pF_DS = true) for five consecutive seconds.

NOTE 2: This defect is defined only when the frame alignment process in the associated <server>/P12s_A_Sk function operates in the automatic CRC4 interworking mode (CRC4mode is AUTO).

NOTE 3: P12s_TT_Sk_MI_CRC4mode signal shall be the same signal as the one used in the associated adaptation sink function (<server>/P12s_A_Sk).

Consequent actions:

aTSF ← CI_SSF
 aRDI ← CI_SSF
 aTSD ← dDEG
 aREI ← nN_B or (not CI_MFP)

NOTE 4: Per CRC-4 multiframe, two RI_REI values are to be conveyed to the associated P12s_TT_So function.

AI_MFP ← CI_MFP
 MI_MFP ← CI_MFP

Defect correlations:

cDEG ← dDEG and MON
 cRDI ← dRDI and MON and RDI_Reported
 cSSF ← CI_SSF and MON and SSF_Reported

Performance monitoring:

The performance monitoring process shall be performed as specified in EN 300 417-1-1 [9], clauses 8.2.4 to 8.2.7 (see note 2).

NOTE 5: Whether or not performance monitoring is actually supported by a network element is determined by the presence of the element management performance monitoring functions.

The function shall support performance monitoring on CRC-4 violations (CRC4V) and on frame alignment signal errors (FASE). This shall be controlled via the CI_MFP signal. For the case CI_MFP is TRUE CRC4V will be applied. Otherwise (CI_MFP is FALSE) FASE will be applied (see figure 48).

NOTE 6: The precise behaviour of the N_EBC counting during the second of the switch over in which MFP changes its value, is not defined in the present document.

pN_DS ← aTSF or dEQ
 pF_DS ← dRDI
 pN_EBC ← ΣnN_B
 pF_EBC ← ΣnF_B

7.3 P12s adaptation functions

7.3.1 P12s to P0-31c adaptation source P12s/P0-31c_A_So

Symbol:

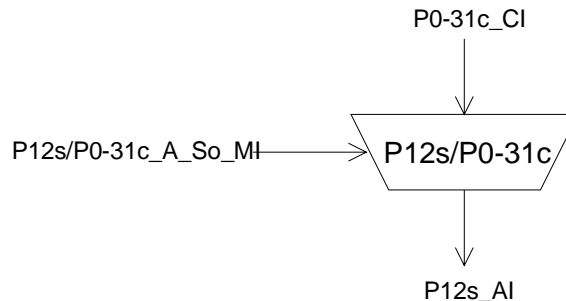

Figure 49: P12s/P0-31c_A_So symbol

Interfaces:

Table 29: P12s/P0-31c_A_So input and output signals

Input(s)	Output(s)
P0-31c_CI_D	P12s_AI_D
P0-31c_CI_CK	P12s_AI_CK
P0-31c_CI_FS	P12s_AI_FS
P0-31c_CI_TSF	P12s_AI_MFS
P12s/P0-31c_A_So_MI_Active	

Processes:

This function passes a 1 984 kbit/s signal without further processing into the appropriate 31 timeslots (TS1 to TS31) of a P12s signal.

The function shall convert the P0-31c frame start signal (P0-31c_CI_FS) identifying TS1 position into a P12s multiframe start signal (P12s_AI_MFS) identifying TS0 byte positions in a 16 frame multiframe structure.

Activation: The function shall access the access point when it is activated (MI_Active is true). Otherwise, it shall not access the access point.

NOTE 1: This function should not be activated when also P12s/SD_A_So function is active. The timing information (CK, MFS, FS) might be different.

NOTE 2: Further specifications are for further study.

Defects: none.

Consequent actions: none.

Defect correlations: none.

Performance monitoring: none.

7.3.2 P12s to P0-31c adaptation sink P12s/P0-31c_A_Sk

Symbol:

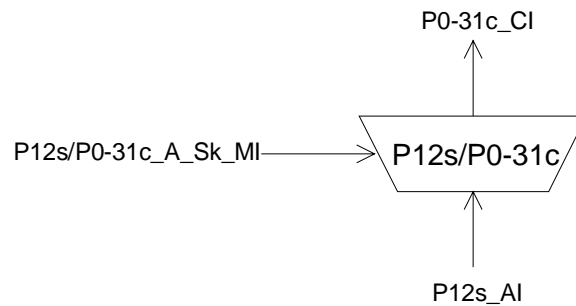

Figure 50: P12s/P0-31c_A_Sk symbol

Interfaces:

Table 30: P12s/P0-31c_A_Sk input and output signals

Input(s)	Output(s)
P12s_AI_D	P0-31c_CI_D
P12s_AI_CK	P0-31c_CI_CK
P12s_AI_FS	P0-31c_CI_FS
P12s_AI_TSF	P0-31c_CI_SSF
P12s/P0-31c_A_Sk_MI_Active	

Processes:

The function extracts the 1 984 kbit/s synchronous signal from the TS1 through TS31 of the P12s_AI (see figures 42 and 45).

Activation: The function shall perform the operation specified above when it is activated (MI_Active is true). Otherwise, it shall transmit the all-ONEs signal at its output (CI_D) and not report its status via the management point.

Defects: none.

Consequent actions:

aSSF ← AI_TSF

aAIS ← AI_TSF

On declaration of the aAIS the function shall output an all-ONEs (AIS) signal in the P0-31c_CI_D within 250 µs; on clearing of aAIS the function shall output normal data within 250 µs. The P0-31c_CI_CK during the all-ONEs signal shall be within 1 984 kHz ± 4,6 ppm.

Defect correlations: none.

Performance monitoring: none.

7.3.3 P12s to SD adaptation source P12s/SD_A_So

Refer to EN 300 417-6-1 [12].

7.3.4 P12s to SD adaptation sink P12s/SD_A_Sk

Refer to EN 300 417-6-1 [12].

7.3.5 P12s to ATM VP compound adaptation source P12s/Avp_A_So

Refer to EN 301 163 [13].

7.3.6 P12s to ATM VP compound adaptation sink P12s/Avp_A_Sk

Refer to EN 301 163 [13].

7.3.7 P12s Layer Clock adaptation source P12s-LC_A_So

Refer to EN 300 417-6-1 [12].

7.3.8 P12s Layer to P0 layer compound adaptation source function P12s/P0X_A_So

Symbol:

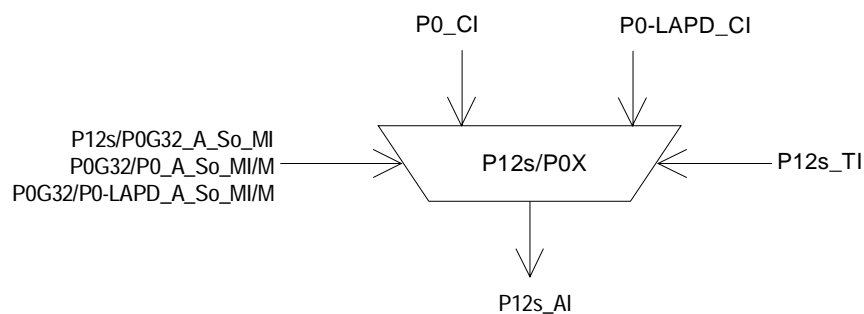

Figure 51: P12s/P0X_A_So symbol

Interfaces:

Table 31: P12s/P0X_A_So input and output signals

Input(s)	Output(s)
P12s/P0G32_A_So_MI P12s_TI maximum 31 inputs: P0_CI P0G32/P0_A_So_MI/M maximum 31 inputs: P0-LAPD_CI P0G32/P0-LAPD_A_So_MI/M	P12s_AI_D P12s_AI_CK P12s_AI_FS P12s_AI_MFS

Processes:

The P12s/P0X_A_So compound function provides adaptation from the P0 layers to the P12s layer. This process is performed by a combination of several atomic functions as shown in figure 52. The P12s/P0G32_A_So function performs the P12s layer specific processing, while the P0G32/P0_A_So and P0G32/P0-LAPD_A_So functions perform the client specific adaptation. Each of these P0G32/P0X_A_So functions is characterized by the parameter M, which define the number of the P0 within the P12s the function has access to (P0 numbering scheme as specified in clause 5.1.1.2 of ITU-T Recommendation G.704 [4], i.e. 0 to 31). According to the P0G32 multiplex structures supported by the NE, a variety of possible combinations of these P0G32/P0X_A_So functions exist. Table 32 lists all possible P0G32/P0X_A_So functions within a P12s/P0X_A_So compound functions.

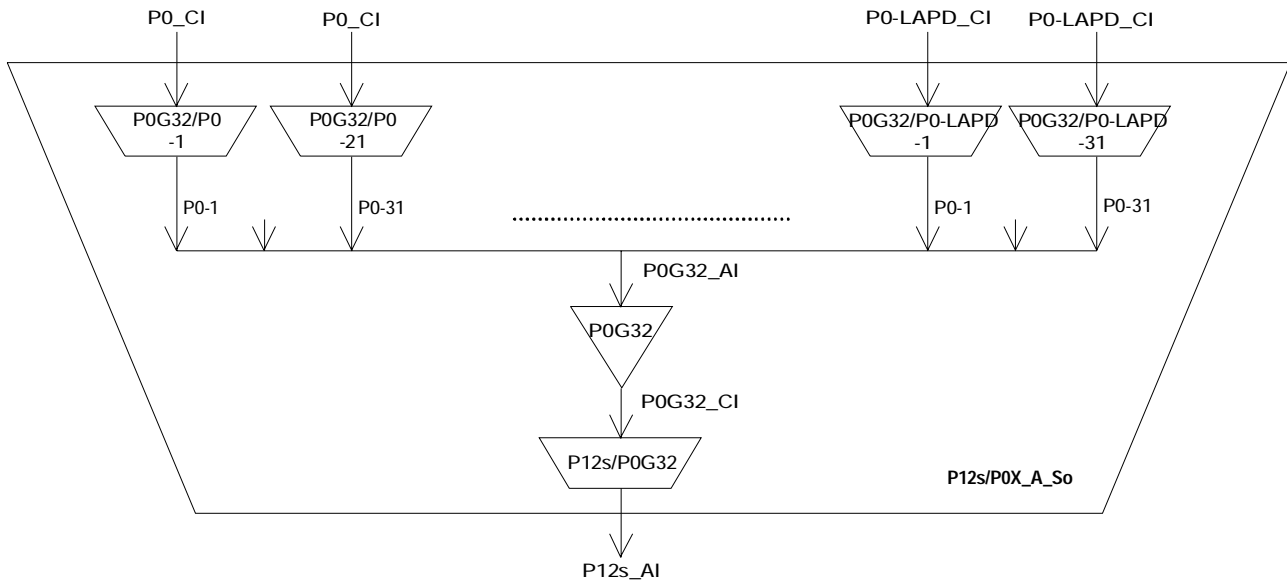

Figure 52: P12s/P0X_A_So symbol

Table 32: Possible P0G32/P0X_A_So functions of a P12s/P0X_A_So compound function

Atomic function	P0 number M
P0G32/P0_A_So/M	1 to 31
P0G32/P0-LAPD_A_So/M	1 to 31

For specific implementations only a subset of these P0G32/P0X_A_So functions may be used (e.g. Channel bank). If a flexible P0G32 multiplex structure is supported, several P0G32/P0X_A_So functions may have access to the same P0 time slot. For such case, only one of these adaptation source functions is allowed to be activated. This is controlled by the equipment management function by activating/deactivating the functions according to the configured P0G32 multiplex structure.

NOTE 1: The P12s/P0G32_A_So, P0G32_T_So and P0G32/P0X_A_So defined in the following clauses can only be used in a P12s/P0X_A_So compound function. These functions can not be used as stand alone functions.

NOTE 2: The P0G32 is a virtual sub-layer only applicable in a P12s/P0X_A compound function.

NOTE 3: The number of P0G32/P0X_A functions that is active shall completely fill the P12s payload.

7.3.8.1 P12s to P0G32 adaptation source P12s/P0G32_A_So

Symbol:

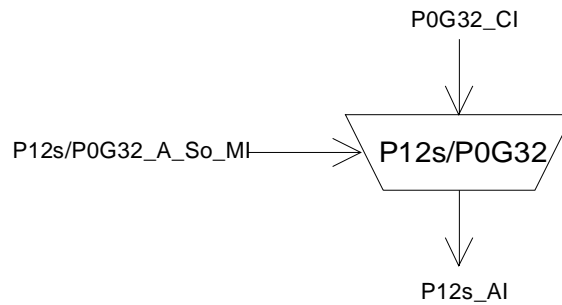

Figure 53: P12s/P0G32_A_So symbol

Interfaces:

Table 33: P12s/P0G32_A_So input and output signals

Input(s)	Output(s)
P0G32_CI_D	P12s_AI_D
P0G32_CI_CK	P12s_AI_CK
P0G32_CI_FS	P12s_AI_FS
P0G32_CI_TSF	
P12s/P0G32_A_So_MI_Active	

Processes:

This function passes a group of 31 P0 signal without further processing into the appropriate 31 timeslots (TS2 to TS32) of a P12s signal.

Activation: The function shall access the access point when it is activated (MI_Active is true). Otherwise, it shall not access the access point.

NOTE 1: This function could be activated when also P12s/SD_A_So function is active. The timing information (CK, MFS, FS) is identical.

Defects: none.

Consequent actions: none.

Defect correlations: none.

Performance monitoring: none.

NOTE 2: The P12s/P0G_A_So functions can only be used in a P12s/PX_A_So compound function. It can not be used as a standalone function.

7.3.8.2 P0G32 termination source function P0G32_T_So

NOTE: The P0G32_T_So function can only be used in a P12s/P0_A_So compound function. It can not be used as a standalone function.

Symbol:

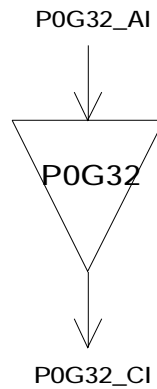

Figure 54: P0G32_T_So symbol

Interfaces:

Table 34: P0G32_T_So input and output signals

Input(s)	Output(s)
P0G32_AI_D	P0G32_CI_D
P0G32_AI_CK	P0G32_CI_CK
P0G32_AI_FS	P0G32_CI_FS
P0G32_AI_MSF	P0G32_CI_MFS

Processes: none.

Defects: none.

Consequent actions: none.

Defect correlations: none.

Performance monitoring: none.

7.3.8.3 P0G32 to P0 layer adaptation source function P0G32/P0_A_So/M

NOTE 1: The P0G32/P0_A_So function can only be used in a P12s/P0_A_So compound function. It can not be used as a standalone function.

Symbol:

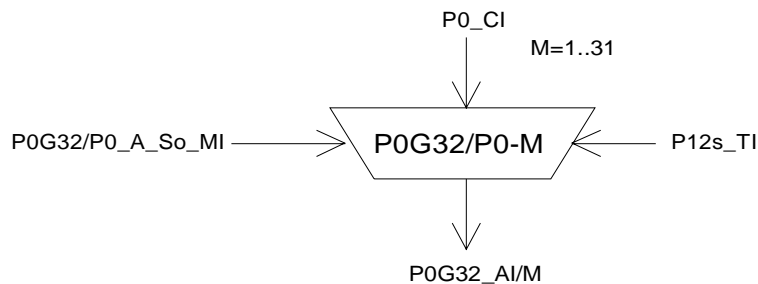

Figure 55: P0G32/P0_A_So symbol

Interfaces:

Table 35: P0G32/P0_A_So input and output signals

Input(s)	Output(s)
P0_CI_D	P0G32_AI_D
P0_CI_CK	P0G32_AI_CK
P0_CI_FS	P0G32_AI_FS
P0_CI_SSF	
P12s_TI_CK	
P12s_TI_FS	
P12s_TI_MFS	
P0G32/P0_A_So_MI_Active	

Processes:

This function multiplex a P0_CI into time a slot M (M = 1..31) of the P0G32_AI/M.

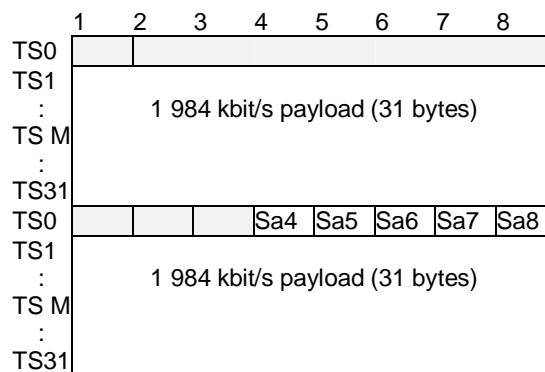

Figure 56: P0G32_AI_D/M signal for P0G32/P0_A_So

Activation: The function shall access the access point when it is activated (MI_Active is true). Otherwise, it shall not access the access point.

Defects: none.

Consequent actions:

aAIS ← CI_SSF

On declaration of aAIS the function shall output an all-ONES signal within 1 ms; on clearing of aAIS the function shall output normal data within 1 ms.

NOTE 2: If CI_SSF is not connected (when connected to a P0_TT_So), CI_SSF is assumed to be false.

Defect correlations: none.

Performance monitoring: none.

7.3.8.4 P0G32 to P0-LAPD layer adaptation source function P0G32/P0-LAPD_A_So/M

NOTE 1: The P0G32/P0-LAPD_A_So function can only be used in a P12s/P0X_A_So compound function. It can not be used as a standalone function.

Symbol:

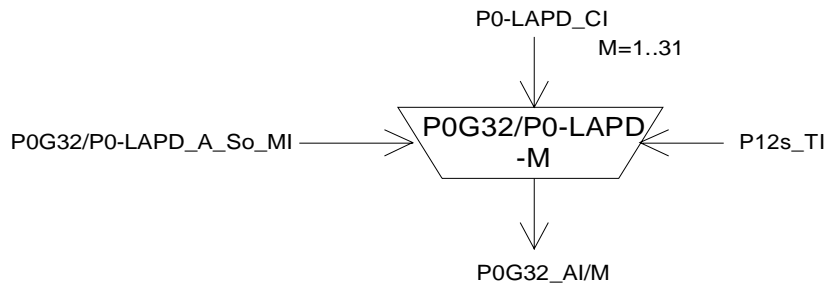

Figure 57: P0G32/P0-LAPD_A_So symbol

Interfaces:

Table 36: P0G32/P0-LAPD_A_So input and output signals

Input(s)	Output(s)
P0-LAPD_CI_D	P0G32_AI_D
P0-LAPD_CI_CK	P0G32_AI_CK
P0-LAPD_CI_FS	P0G32_AI_FS
P0-LAPD_CI_SSF	
P12s_TI_CK	
P12s_TI_FS	
P12s_TI_MFS	
P0G32/P0-LAPD_A_So_MI_Active	

Processes:

This function multiplex a P0-LAPD_CI according to Q.921 into a time slot M (M = 1..31) of the P0G32_AI/M.

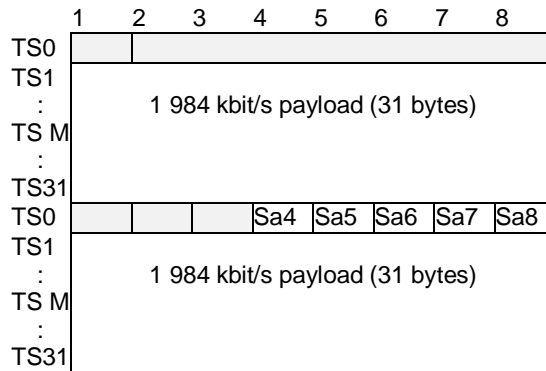

Figure 58: P0G32_AI_D/M signal for P0G32/P0-LAPD_A_So

Activation: The function shall access the access point when it is activated (MI_Active is true). Otherwise, it shall not access the access point.

Defects: none.

Consequent actions:

aAIS ← CI_SSF

On declaration of aAIS the function shall output an all-ONES signal within 1 ms; on clearing of aAIS the function shall output normal data within 1 ms.

NOTE 2: If CI_SSF is not connected (when connected to a P0_TT_So), CI_SSF is assumed to be false.

Defect correlations: none.

Performance monitoring: none.

7.3.9 P12s layer to P0X layer compound adaptation sink function P12s/P0X_A_Sk

Symbol:

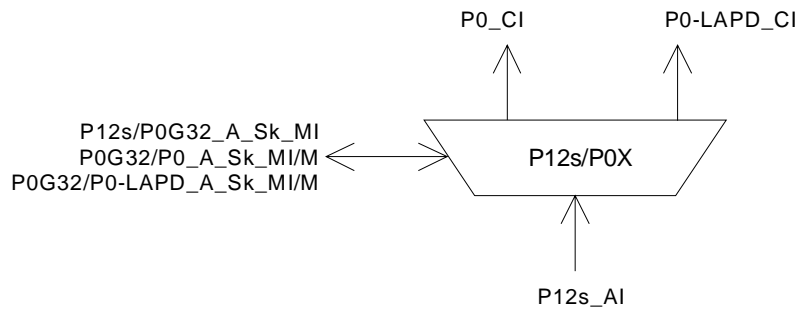

Figure 59: P12s/P0X_A_Sk symbol

Interfaces:

Table 37: P12s/P0G32_A_Sk input and output signals

Input(s)	Output(s)
P12s_AI	P12s/P0G32_A_Sk_MI
P12s/P0G32_A_Sk_MI	maximum 31 outputs:
maximum 31 inputs:	P0_CI
P0G32/P0_A_Sk_MI/M	P0G32/P0_A_Sk_MI/M
maximum 31 inputs:	maximum 31 outputs:
P0G32/P0-LAPD_A_Sk_MI/M	P0-LAPD_CI
	P0G32/P0-LAPD_A_Sk_MI/M

Processes:

The P12s/P0X_A_Sk compound function provides adaptation from the P12s layer to the P0X layers. This process is performed by a combination of several atomic functions as shown in figure 60. The P12s/P0G32_A_Sk function performs the P12s layer specific slip buffer processing, while the P0G32/P0X_A_Sk functions perform the lower order P0 specific adaptation. Each of these P0G32/P0X_A_Sk functions is characterized by the parameter M, which define the time slot number of the P0 within the P12s the function has access to (P0 numbering scheme as specified in clause 5.1.1.2 of ITU-T Recommendation G.704 [4], i.e. 0 to 31). According to the P0G32 multiplex structures supported by the NE, a variety of possible combinations of these P0G32/P0X_A_Sk functions exist. Table 38 lists all possible P0G32/P0X_A_Sk functions within a P12s/P0X_A_Sk compound function.

NOTE 1: Sub-rates below 64 kbit/s rate is for further study.

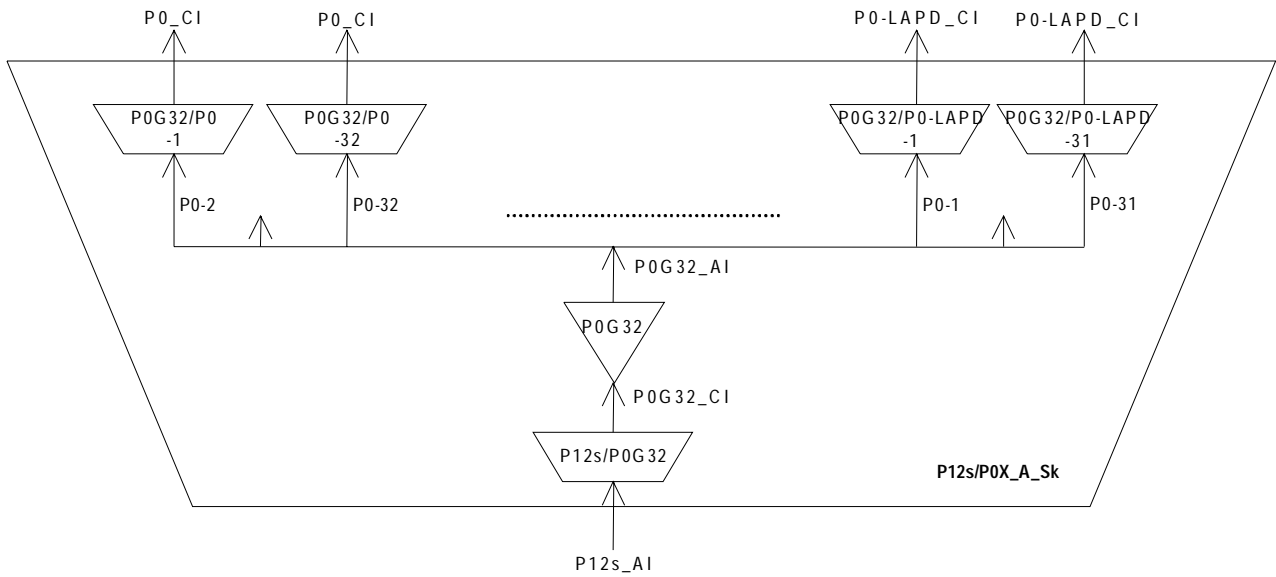

Figure 60: P12s/P0X_A_Sk compound function with set of P12s/P0_A_Sk atomic functions

Table 38: Possible P0G32/P0X_A_Sk functions of a P12s/P0X_A_Sk compound function

Atomic function	P0 number M
P0G32/P0_A_Sk/M	1 to 31
P0G32/P0-LAPD_A_Sk/M	1 to 31

For specific implementations only a subset of these P0G32/P0X_A_Sk functions may be used (e.g. PCM channel bank). If a flexible P0G32 multiplex structure is supported, several P0G32/P0X_A_Sk functions may have access to the same P0 timeslot. In contradiction with the source direction, adaptation sink functions may be activated all together. This will presumably cause events (e.g. pN_CS) to be detected and reported. To prevent this an adaptation sink function can be deactivated. This is controlled by the equipment management function by activating/deactivating the functions according to the configured P0G32 multiplex structure.

NOTE 2: The P12s/P0G32_A_Sk, P0GG24_T_Sk and P0G32/P0_A_Sk defined in the following clauses can only be used in a P12s/X_A_Sk compound function. These functions can not be used as stand alone functions.

NOTE 3: The P0G32 is a virtual sub-layer only applicable in a P12s/P0X_A compound function.

7.3.9.1 P12s layer to P0G32 adaptation sink function P12s/P0G32_A_Sk

NOTE 1: The P12s/P0G32_A_Sk function can only be used in a P12s/P0X_A_Sk compound function. It can not be used as a standalone function.

Symbol:

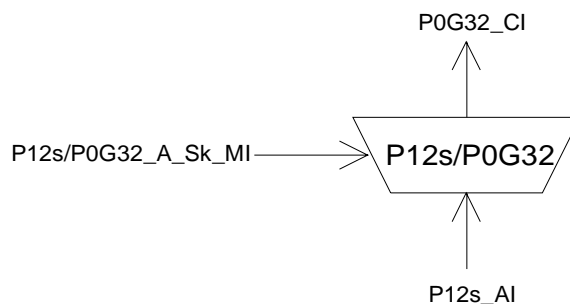

Figure 61: P12s/P0G32_A_Sk symbol

Interfaces:**Table 39: P12s/P0G32_A_Sk input and output signals**

Input(s)	Output(s)
P12s_AI_D	P0G32_CI_D
P12s_AI_CK	P0G32_CI_SSF
P12s_AI_FS	P0G32_MI_pN_CS
P12s_AI_TSF	
P0G32_CI_CK	
P0G32_CI_FS	
P12s/P0G32_A_Sk_MI_1second	
P12s/P0G32_A_Sk_MI_Active	

Processes:

The function performs rate adaptation between the P12s and the P0G32 by means of frame slip. The function shall tolerate jitter and wander according to ITU-T Recommendation G.823 [8] without any impairment. Wander outside the limits and frequency deviations shall result in controlled 125µs frame slips.

Activation: The function shall perform the operation specified above when it is activated (MI_Active is true). Otherwise, it shall transmit the all-ONEs signal at its output (CI_D) and not report its status via the management point.

Defects: none.

Consequent actions:

aSSF ← AI_TSF

aAIS ← AI_TSF

On declaration of aAIS the function shall output an all-ONEs signal within 1 ms; on clearing of aAIS the function shall output normal data within 1 ms.

NOTE 2: If AI_TSF is not connected (when connected to a PO_TT_So), AI_TSF is assumed to be false.

Defect correlations: none.

Performance monitoring:

The performance monitoring process shall be performed as specified in ITU-T recommendation M.2100 clause 5.2.2 and annex B.

NOTE 3: Whether or not performance monitoring is actually supported by a network element is determined by the presence of the element management performance monitoring functions.

The function shall support performance monitoring on controlled frame slips.

pN_CS ← Number of controlled frame slips

7.3.9.2 P0G32 termination sink function TUG_T_Sk

NOTE: The P0G32_T_Sk function can only be used in a P12s/P0X_A_Sk compound function. It can not be used as a standalone function.

Symbol:

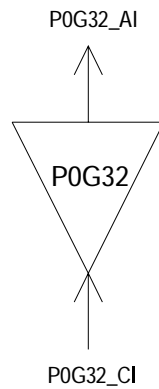

Figure 62: P0G32_T_Sk symbol

Interfaces:

Table 40: P0G32_T_Sk input and output signals

Input(s)	Output(s)
P0G32_CI_D	P12s_AI_D
P0G32_CI_CK	P12s_AI_CK
P0G32_CI_FS	P12s_AI_FS
P0G32_CI_TSF	
P12s/P0G32_A_So_MI_Active	

Processes: none.

Defects: none.

Consequent actions:

aTSF ← CI_SSF

Defect correlations: none.

Performance monitoring: none.

7.3.9.3 P0G32 to P0 layer adaptation sink function P0G32/P0_A_Sk/M

NOTE 1: The P0G32/P0_A_Sk function can only be used in a P12s/P0X_A_Sk compound function. It can not be used as a standalone function

Symbol:

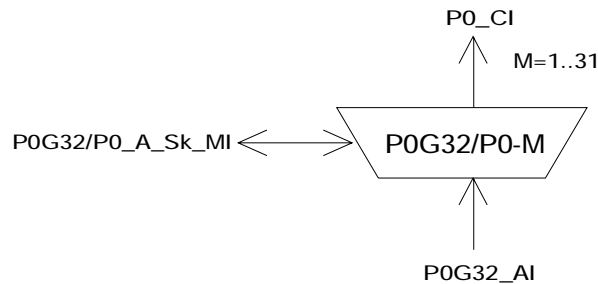

Figure 63: P0G32/P0_A_Sk symbol

Interfaces:**Table 41: P0G32/P0_A_Sk input and output signals**

Input(s)	Output(s)
P0G32_AI_D	P0_CI_D
P0G32_AI_CK	P0_CI_CK
P0G32_AI_FS	P0_CI_FS
P0G32_AI_TSF	P0_CI_SSF
P0G32/P0_A_Sk_MI_Active	

Processes:

This function de-multiplex a P0_CI from time slot M (M = 1..31) in the P0G32_AI/M.

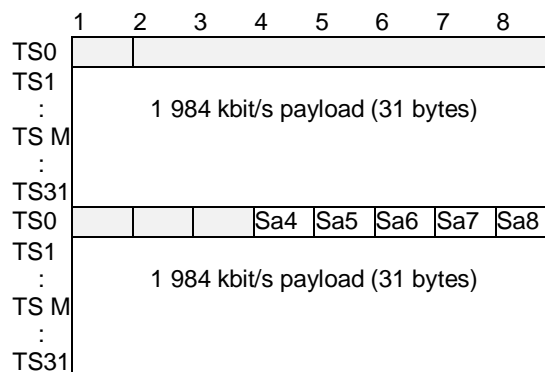
**Figure 64: P0G32_AI_D/M signal for P0G32/P0_A_So**

Activation: The function shall access the access point when it is activated (MI_Active is true). Otherwise, it shall not access the access point.

Defects: none.

Consequent actions:

aAIS ← AI_TSF

On declaration of aAIS the function shall output an all-ONES signal within 1 ms; on clearing of aAIS the function shall output normal data within 1 ms.

NOTE 2: If AI_TSF is not connected (when connected to a P0_TT_So), AI_TSF is assumed to be false.

Defect correlations: none.

Performance monitoring: none.

7.3.9.4 P0G32 to P0-LAPD layer adaptation sink function P0G32/P0-LAPD_A_Sk/M

NOTE 1: The P0G32/P0-LAPD_A_Sk function can only be used in a P12s/P0X_A_Sk compound function. It can not be used as a standalone function.

Symbol:

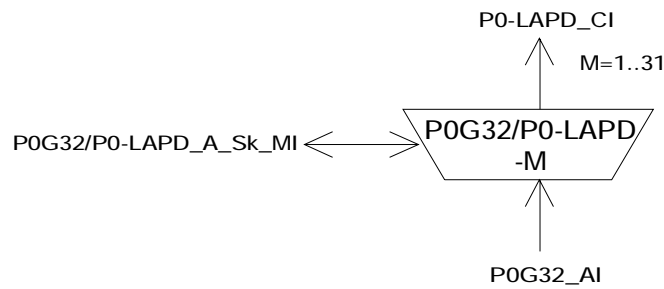

Figure 65: P0G32/P0-LAPD_A_Sk symbol

Interfaces:

Table 42: P0G32/P0-LAPD_A_Sk input and output signals

Input(s)	Output(s)
P0G32_AI_D	P0-LAPD_CI_D
P0G32_AI_CK	P0-LAPD_CI_CK
P0G32_AI_FS	P0-LAPD_CI_FS
P0G32_AI_TSF	P0-LAPD_CI_SSF
P0G32/ P0-LAPD_A_Sk_MI_AIS_Reported	
P0G32/ P0-LAPD_A_Sk_MI_Active	

Processes:

This function de-multiplex a P0-LAPD_CI according to Q.921 from time slot M (M = 1..31) in the P0G32_AI/M.

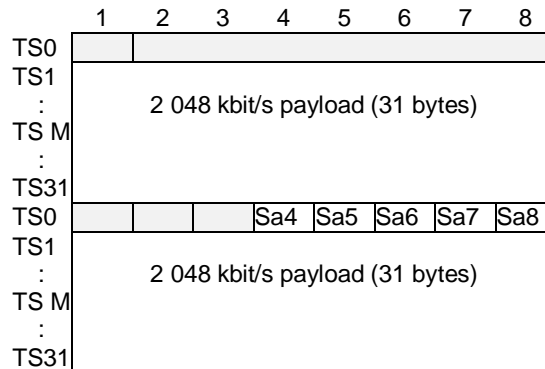

Figure 66: P0G32_AI_D/M signal for P0G32/P0-LAPD_A_So

Activation: The function shall access the access point when it is activated (MI_Active is true). Otherwise, it shall not access the access point.

Defects: none.

Consequent actions:

aAIS ← AI_TSF

On declaration of aAIS the function shall output an all-ONEs signal within 1 ms; on clearing of aAIS the function shall output normal data within 1 ms.

NOTE 2: If AI_TSF is not connected (when connected to a P0-LAPD_TT_So), AI_TSF is assumed to be false.

Defect correlations: none.

Performance monitoring: none.

7.3.10 P12s layer to V3-SM layer adaptation source function P12s/P0X_A_So

Inserts the Sa5 bits and Sa6 nibbles for the purpose of the V3 Section maintenance. For further study.

7.3.11 P12s layer to V3-SM layer adaptation source function P12s/P0X_A_Sk

Evaluates the A, Sa5 bits and Sa6 nibbles for the purpose of the V3 Section maintenance. For further study.

7.4 P12s layer monitoring functions

7.4.1 P12s layer non-intrusive monitoring function P12sm_TT_Sk

Symbol:

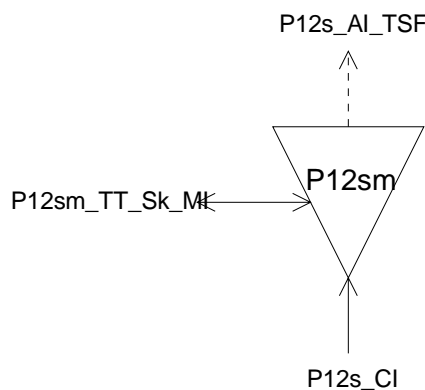

Figure 67: P12sm_TT_Sk symbol

Interfaces:

Table 43: P12sm_TT_Sk input and output signals

Input(s)	Output(s)
P12s_CI_D	P12s_AI_TSF
P12s_CI_CK	P12s_AI_TSD
P12s_CI_FS	P12sm_TT_Sk_MI_cSSF
P12s_CI_MFS	P12sm_TT_Sk_MI_cDEG
P12s_CI_SSF	P12sm_TT_Sk_MI_cRDI
P12s_CI_MFP	P12sm_TT_Sk_MI_RNCI
P12sm_TT_Sk_MI_TPmode	P12sm_TT_Sk_MI_MFP
P12sm_TT_Sk_MI_SSF_Reported	P12sm_TT_Sk_MI_pN_EBC
P12sm_TT_Sk_MI_RDI_Reported	P12sm_TT_Sk_MI_pN_DS
P12sm_TT_Sk_MI_DEGM	P12sm_TT_Sk_MI_pF_EBC
P12sm_TT_Sk_MI_DEGTHR	P12sm_TT_Sk_MI_pF_DS
P12sm_TT_Sk_MI_1second	
P12sm_TT_Sk_MI_CRC4mode	

Processes:

This function monitors a P12s for errors, and recovers the trail termination status. It extracts the payload independent overhead bits ($C_1C_2C_3C_4$, A, E) from the P12s layer characteristic.

FAS: If CI_MFP is FALSE, the FAS bits of each received double frame are compared to their expected value "0011011". A difference is taken as evidence of one or more errors (nN_B) in the block.

C₁C₂C₃C₄: If CI_MFP is TRUE, CRC-4 is computed for each bit of the preceding P12s submultiframe and compared with bits C₁C₂C₃C₄ recovered from the current submultiframe. A difference between the computed and recovered C₁C₂C₃C₄ values is taken as evidence of one or more errors (nN_B) in the computation block.

A, E: The information carried in the A and E bits (RDI, REI) is extracted to enable single ended maintenance of a bi-directional Trail (Path). The REI (nF_B) is used to monitor the error performance of the other direction of transmission, and the RDI provides information as to the status of the remote receiver. A "1" indicates a Remote Defect Indication state, while a "0" indicates the normal, working state. The application process is described in EN 300 417-1-1 [9], clauses 7.4.2 (REI), 7.4.11 and 8.2 (RDI). If CI_MFP is FALSE, nF_B is set to 0. If CI_MFP is true, nF_B is REI.

Defects:

The function shall detect for dRDI defect according the specification in EN 300 417-1-1 [9], clause 8.2.1.

The function shall detect for dDEG defect as specified in EN 300 417-1-1 [9] with the following extensions (see figure 48): the Error Detection Code Violation (EDCV) process shall assume "zero" EDCVs in the incoming signal if CI_MFP is FALSE, and dDEG shall be cleared when CI_MFP is FALSE.

NOTE 1: The precise behaviour of the N_EBC counting during the second of the switch over in which MFP changes its value, is not defined in the present document.

The function shall detect a CRC-4 multiframe generator/detector status (MI_RNCI) if (pF_EBC > 990 and pF_DS = false) for five consecutive seconds. The MI_RNCI status shall be cleared if (pF_EBC < 990 or pF_DS = true) for five consecutive seconds.

NOTE 2: This defect is defined only when the frame alignment process in the associated <server>/P12s_A_Sk function operates in the automatic CRC4 interworking mode (CRC4mode is AUTO).

NOTE 3: P12sm_TT_Sk_ML_CRC4mode signal shall be the same signal as the one used in the associated adaptation sink function (<server>/P12s_A_Sk).

Consequent actions:

aTSF ← CI_SSF
 aTSD ← dDEG
 MI_MFP ← CI_MFP

Defect correlations:

cDEG ← dDEG and MON
 cRDI ← dRDI and MON and RDI_Reported
 cSSF ← CI_SSF and MON and SSF_Reported

Performance monitoring:

The performance monitoring process shall be performed as specified in EN 300 417-1-1 [9], clauses 8.2.4 to 8.2.7 (see note 2).

NOTE 4: Whether or not performance monitoring is actually supported by a network element is determined by the presence of the element management performance monitoring functions.

The function shall support performance monitoring on CRC-4 violations (CRC4V) and on frame alignment signal errors (FASE). This shall be controlled via the CI_MFP signal. For the case CI_MFP is TRUE CRC4V will be applied. Otherwise (CI_MFP is FALSE) FASE will be applied (see figure 48).

pN_DS ← aTSF or dEQ
 pF_DS ← dRDI

pN_EBC ← ΣnN_B

pF_EBC ← ΣnF_B

8 P31s path layer functions

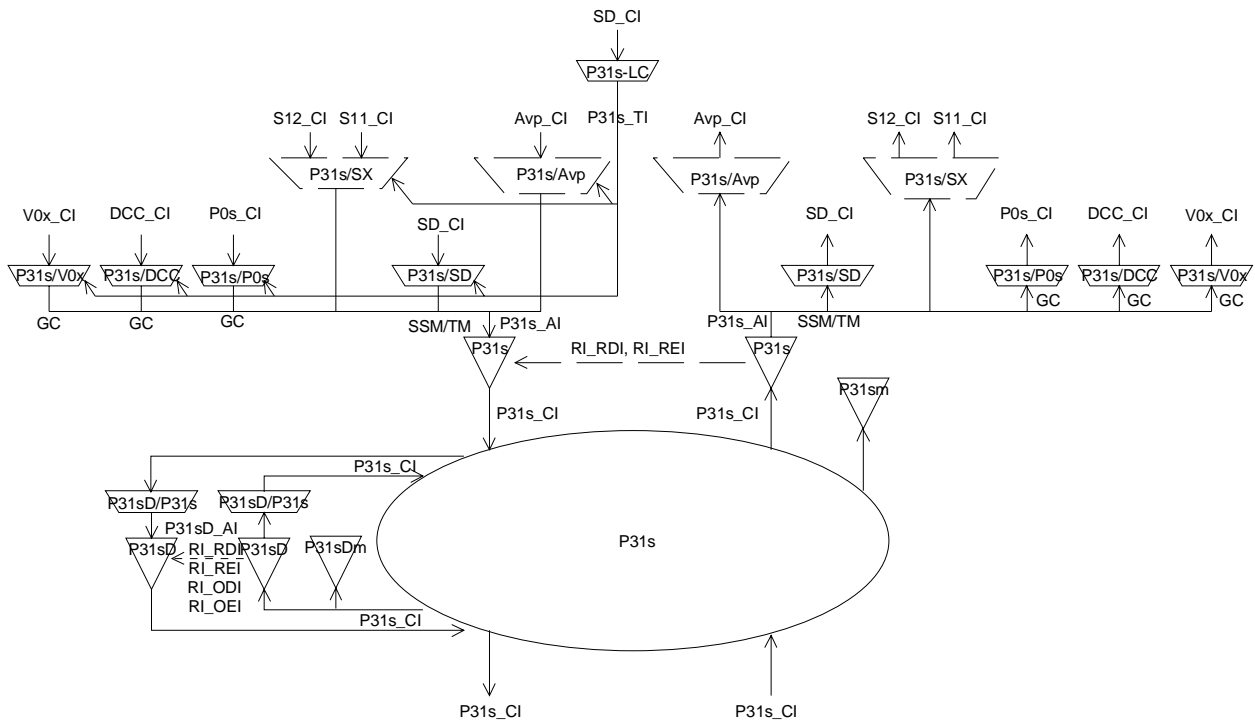

Figure 68: P31s path layer atomic functions

P31s layer CP

The Characteristic Information (CI) at this point is octet structured with an 125 μ s frame (see figure 69). Its format is characterized as P31s_AI plus the P31s trail termination overhead in the TR, EM, and MA locations as defined in ETS 300 337 [10]. For the case the signal has passed the tandem connection sublayer, P31s_CI has defined P31s tandem connection trail termination overhead in location NR.

NOTE 1: NR will be undefined when the signal P31s_CI has not been processed in a tandem connection adaptation and trail termination function.

NOTE 2: An unequipped P31s signal is for further study.

P31s layer AP

The Adaptation Information (AI) at this point is octet structured with an 125 μ s frame (see figure 69). It represents adapted client layer information comprising 530 bytes of client layer information, the signal label bits in byte MA, the multiframe indicator in byte MA, the synchronization status message/timing marker bit in byte MA, and a 64 kbit/s general communication channel in byte GC.

NOTE 3: GC will be undefined when no GC byte adaptation source function is connected to the AP.

The composition of the payload transported by an P31s will be determined by the client layer application. Typical compositions of the payload include:

- a TU-12 structured signal;
- an ATM 33 920 kbit/s cell stream signal.

Figure 68 shows that more than one adaptation function exists in this P31s layer that can be connected to one P31s access point. For the case of the adaptation source functions, only one of these adaptation source functions is allowed to be activated. For this activated source, access to the access point by other adaptation source functions shall be denied. In contradiction with the source direction, adaptation sink functions may be activated all together. This may cause faults (e.g. cLOF) to be detected and reported. To prevent this an adaptation sink function can be deactivated.

NOTE 4: If one adaptation function only is connected to the AP, it will be activated. If one or more other functions are connected to the same AP, one out of the set of functions will be active.

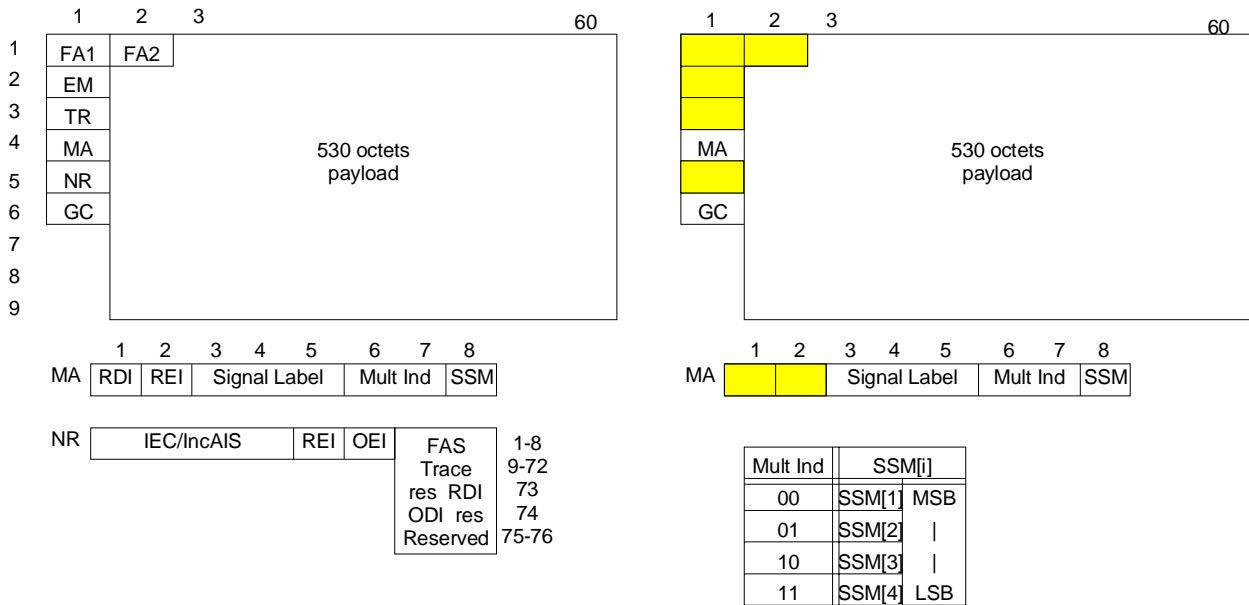

Figure 69: P31s_CI_D (left) and P31s_AI_D (right)

8.1 P31s connection functions

For further study.

8.2 P31s trail termination functions

8.2.1 P31s trail termination source P31s_TT_So

Symbol:

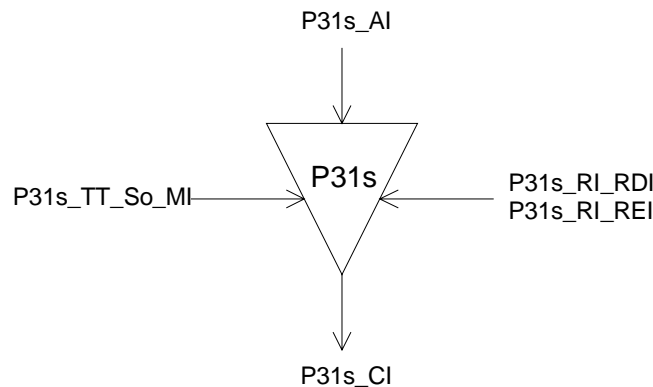

Figure 70: P31s_TT_So symbol

Interfaces:**Table 44: P31s_TT_So input and output signals**

Input(s)	Output(s)
P31s_AI_D P31s_AI_CK P31s_AI_FS P31s_RI_RDI P31s_RI_REI P31s_TT_So_ML_TxTI	P31s_CI_D P31s_CI_CK P31s_CI_FS

Processes:

This function adds error monitoring, status overhead bytes, trace identifier and the frame alignment signal to the P31s_AI presented at its input, to form the P31s layer Characteristic Information. The processing of the trail termination overhead bytes is defined as follows:

TR: In this byte the function shall insert the Transmitted Trail Trace Identifier TxTI. Its format is described in EN 300 417-1-1 [9], clause 7.1.

MA[1]: Bit 1, a RDI indication, shall be set to "1" on activation of the RI_RDI within 1 ms, determined by the associated P31s_TT_Sk function, and set to "0" within 1 ms on clearing of RI_RDI.

MA[2]: Bit 2, a REI (Remote Error Indication) indication, shall be set to "1" within 1 ms on declaration of RI_REI - determined by the associated P31s_TT_Sk function if one or more errors were detected by the BIP-8 process - and shall be otherwise set to zero within 1 ms.

EM: In this byte the function shall insert the BIP-8 EDC with even bit parity. Each bit n of current EM is computed to provide even parity over the n^{th} bit of every byte in the previous frame of the Characteristic Information P31s_CI, i.e. EM is calculated over the entire previous P31s signal. Further reference is provided in EN 300 417-1-1 [9], clause 7.3 and ETS 300 337 [10].

FA1FA2 - Frame Alignment Signal (FAS): The function shall insert the 34 368 kbit/s 125 μ s frame alignment signal FA1FA2 into the frame overhead as defined in ETS 300 337 [10] and depicted in figure 69.

Defects: none.

Consequent actions: none.

Defect correlations: none.

Performance monitoring: none.

8.2.2 P31s trail termination sink P31s_TT_Sk

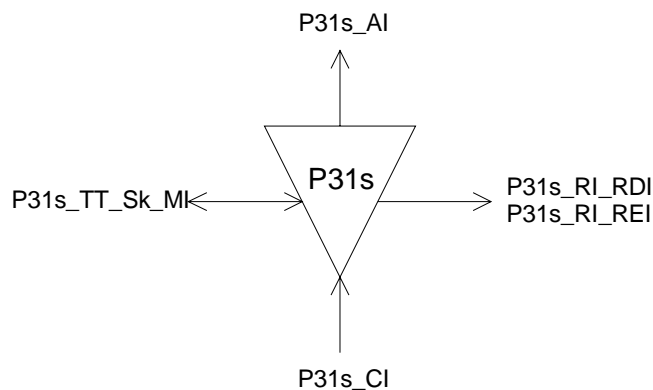
Symbol:**Figure 71: P31s_TT_Sk symbol**

Interfaces:**Table 45: P31s_TT_Sk input and output signal**

Input(s)	Output(s)
P31s_CI_D	P31s_AI_D
P31s_CI_CK	P31s_AI_CK
P31s_CI_FS	P31s_AI_FS
P31s_CI_SSF	P31s_AI_TSF
P31s_TT_Sk_MI_TPmode	P31s_AI_TSD
P31s_TT_Sk_MI_SSF_Reported	P31s_TT_Sk_MI_cTIM
P31s_TT_Sk_MI_ExTI	P31s_TT_Sk_MI_cUNEQ
P31s_TT_Sk_MI_RDI_Reported	P31s_TT_Sk_MI_cDEG
P31s_TT_Sk_MI_DEGTHR	P31s_TT_Sk_MI_cRDI
P31s_TT_Sk_MI_DEGM	P31s_TT_Sk_MI_cSSF
P31s_TT_Sk_MI_1second	P31s_TT_Sk_MI_AcTI
P31s_TT_Sk_MI_TIMdis	P31s_RI_RDI
	P31s_RI_REI
	P31s_TT_Sk_MI_pN_EBC
	P31s_TT_Sk_MI_pF_EBC
	P31s_TT_Sk_MI_pN_DS
	P31s_TT_Sk_MI_pF_DS

Processes:

This function monitors for 34 Mbit/s frame errors and recovers the trail termination status as defined in ETS 300 337 [10]. It extracts the payload independent overhead bytes EM, TR, MA bits 1, 2 from the P31s layer Characteristic information:

EM: Even bit parity (BIP-8) shall be computed for each bit n of every byte of the preceding frame and compared with bit n of EM recovered from the current frame (n=1 to 8 inclusive). A difference between the computed and recovered EM values shall be taken as evidence of one or more errors (nN_B) in the computation block.

TR: The 16 byte Trail Trace Identifier (TTI) shall be recovered from the TR byte and shall be made available for network management purposes. The application and the acceptance and mismatch detection process shall be performed as described in the EN 300 417-1-1 [9], clauses 7.1 and 8.2.1.3.

The trace identifier process in this function is required to support "mode 1" (EN 300 417-1-1 [9], clause 7.1) only. "Transmission and Multiplexing (TM); Generic requirements of transport functionality of equipment; Part 1-1: Generic processes and performance" P31s connection equipment does not exist.

MA[1-2]: The relevant information carried in the MA byte (RDI in bit 1, REI in bit 2) shall be extracted to enable single ended maintenance of a bi-directional Trail. The REI (nF_B) shall be used to monitor the error performance of the reverse direction of transmission; the RDI provides information as to the status of the remote receiver. A "1" indicates a RDI state, while a "0" indicates the normal working state. The application process shall be performed as specified in EN 300 417-1-1 [9], clauses 7.4.2 (REI), 7.4.11 and 8.2 (RDI).

MA[3-5]: The information in the signal label bits shall be extracted to allow unequipped P31s defect detection.

Defects:

The detection and removal conditions and processes for dUNEQ, dDEG, dRDI and dTIM are described in EN 300 417-1-1 [9], clause 8.2.1.

Consequent actions:

aAIS	←	dUNEQ or dTIM
aRDI	←	CI_SSF or dUNEQ or dTIM
aTSF	←	CI_SSF or dUNEQ or dTIM
aTSD	←	dDEG
aREI	←	"#EDCV"

On declaration of an aAIS the function shall output an all ONEs signal within 250 μs; on clearing of aAIS the function shall output normal data within 250 μs.

Defect correlations:

- cUNEQ ← MON and dUNEQ
- cTIM ← MON and dTIM (and not dUNEQ)
- cDEG ← MON and dDEG and (not dUNEQ) and (not dTIM)
- cRDI ← MON and dRDI and (not dTIM) and (not dUNEQ) and RDI_Reported
- cSSF ← MON and CI_SSF and SSF_Reported

It shall be an option to report SSF as a fault cause. This is controlled by means of the parameter SSF_Reported. The default shall be SSF_Reported = false.

It shall be an option to report RDI as a fault cause. This is controlled by means of the parameter RDI_Reported. The default shall be RDI_Reported = false.

Performance monitoring:

The performance monitoring process shall be performed as specified in EN 300 417-1-1 [9], clauses 8.2.4 to 8.2.7.

- pN_DS ← aTSF or dEQ
- pF_DS ← dRDI
- pN_EBC ← ΣnN_B
- pF_EBC ← ΣnF_B

8.3 P31s adaptation functions

8.3.1 P31s layer to VC-12, VC-11 layer compound adaptation source function P31s/SX_A_So

Symbol:

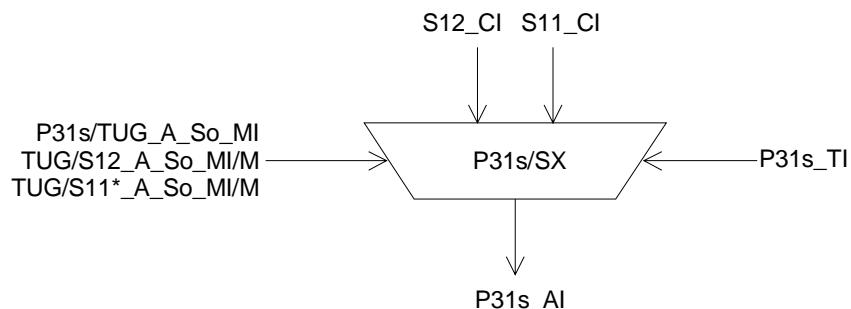

Figure 72: P31s/SX_A_So symbol

Interfaces:**Table 46: P31s/SX_A_So input and output signals**

Input(s)	Output(s)
P31s/TUG_A_So_MI P31s_TI	P31s_AI
maximum 14 inputs: S12_CI TUG/S12_A_So_MI/M	
maximum 14 inputs: S11_CI TUG/S11*_A_So_MI/M	

Processes:

The P31s/SX_A_So compound function provides adaptation from the VC-12/11 layers to the P31s layer. This process is performed by a combination of several atomic functions as shown in figure 73. The P31s/TUG_A_So function performs the P31s layer specific signal label and multiframe processing, while the TUG/S12_A_So and TUG/S11*_A_So functions perform the lower order VC specific frequency justification and bitrate adaptation. Each of these TUG/Sm_A_So functions is characterized by the parameter M, which define the number of the TU within the P31s the function has access to (TU numbering scheme as specified in ETS 300 337 [10], clause 5.3). According to the TUG multiplex structures supported by the NE, a variety of possible combinations of these TUG/Sm_A_So functions exists. Table 47 lists all possible TUG/Sm_A_So functions within a P31s/SX_A_So compound functions.

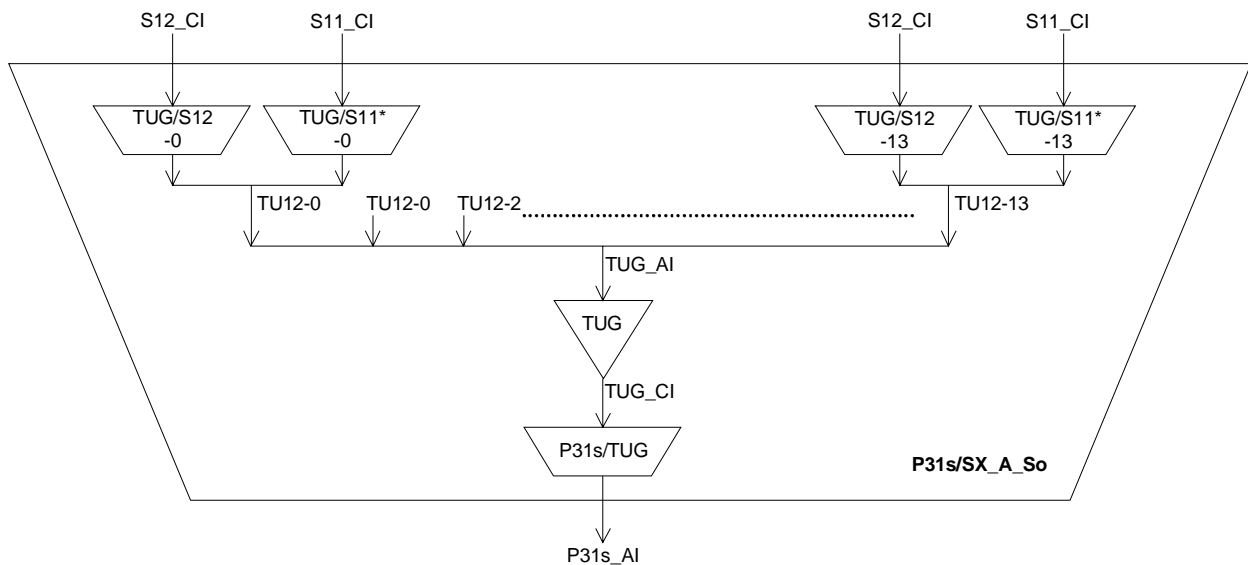
**Figure 73: P31s/SX_A_So compound function with set of P31s/Sm_A_So atomic functions****Table 47: Possible TUG/Sm_A_So functions of a P31s/SX_A_So compound function**

Atomic function	TU-12 number M
TUG/S12_A_So/M	0 to 13
TUG/S11*_A_So/M	0 to 13

For specific implementations only a subset of these TUG/Sm_A_So functions may be used (e.g. a terminal multiplexer with fixed 2 Mbit/s access has 14 TUG/S12_A_So functions). If a flexible TUG multiplex structure is supported, several TUG/Sm_A_So functions may have access to the same TU timeslot. For such case, only one of these adaptation source functions is allowed to be activated. This is controlled by the equipment management function by activating/deactivating the functions according to the configured TUG multiplex structure.

NOTE 1: The P31s/TUG_A_So, TUG_T_So and TUG/Sm_A_So (m = 12, 11*) defined in the following clauses can only be used in a P31s/SX_A_So compound function. These functions can not be used as stand alone functions.

NOTE 2: The TUG is a virtual sub-layer only applicable in a P31s/SX_A compound function.

NOTE 3: The number of TUG/Sm_A (m=12,11*) functions that is active shall completely fill the P31s payload.

8.3.1.1 P31s layer to TUG adaptation source function P31s/TUG_A_So

Symbol:

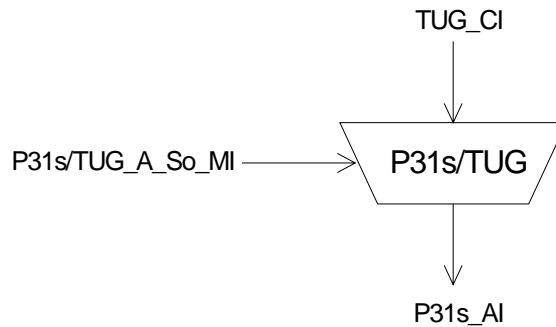

Figure 74: P31s/TUG_A_So symbol

Interfaces:

Table 48: P31s/TUG_A_So input and output signals

Input(s)	Output(s)
TUG_CI_D TUG_CI_CK TUG_CI_FS TUG_CI_MFS P31s/TUG_A_So_MI_Active	P31s_AI_D P31s_AI_CK P31s_AI_FS
NOTE: The P31s/TUG_A_So functions can only be used in a P31s/SX_A_So compound function. It can not be used as a stand alone function.	

Processes:

The function adds two payload specific signals (bits MA[3-5] and MA[6-7]) to the P31s POH and fixed stuff (R) bytes to the P31s payload (see figure 76).

MA[3-5]: In this byte the function shall insert code "011" (TU-12 structure) as defined in ETS 300 337 [10].

MA[6-7]: The value of the multiframe indicator bits shall be set as specified by ETS 300 337 [10], 500 μs TU multiframe sequence, and aligned with TUG_CI_MFS.

					TU multiframe indicator		
1	2	3	4	5	6	7	8

Figure 75: TU multiframe indicator bits in byte MA

R - Fixed Stuff bytes: The fixed stuff bytes R are undefined.

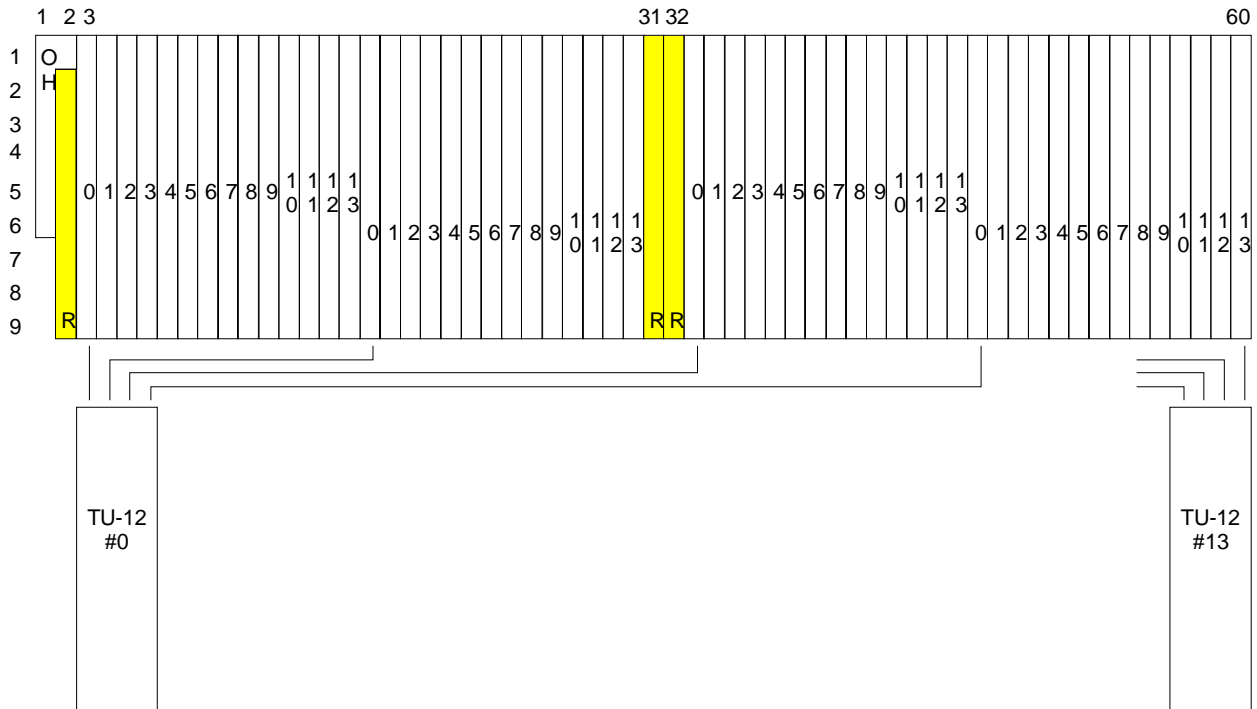

Figure 76: P31s payload (TU-12s and fixed stuff "R" bytes) and TU-12 numbering scheme

Activation: The function shall access the access point when it is activated (MI_Active is true). Otherwise, it shall not access the access point.

- Defects:** none.
- Consequent actions:** none.
- Defect correlations:** none.
- Performance monitoring:** none.

8.3.1.2 TUG termination source function TUG_T_So

Symbol:

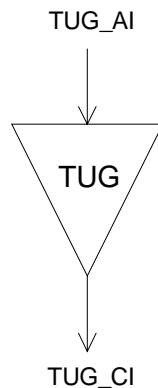

Figure 77: TUG_T_So symbol

Interfaces:**Table 49: TUG_T_So input and output signals**

Input(s)	Output(s)
TUG_AI_D	TUG_CI_D
TUG_AI_CK	TUG_CI_CK
TUG_AI_FS	TUG_CI_FS
TUG_AI_MFS	TUG_CI_MFS

NOTE: The TUG_T_So functions can only be used in a P31s/SX_A_So compound function. It can not be used as a stand alone function.

Processes: none.

Defects: none.

Consequent actions: none.

Defect correlations: none.

Performance monitoring: none.

8.3.1.3 TUG to VC-12 layer adaptation source function TUG/S12_A_So/M

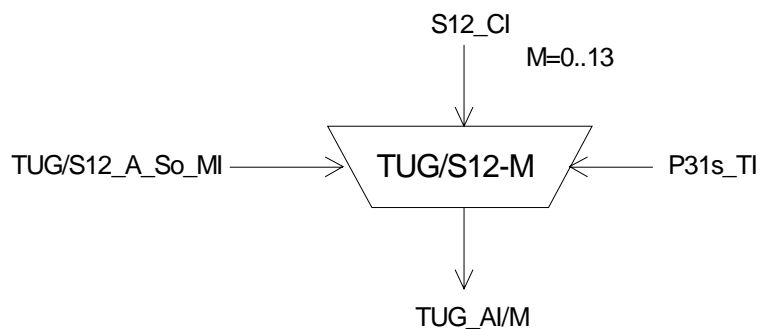
Symbol:**Figure 78: TUG/S12_A_So symbol****Interfaces:****Table 50: TUG/S12_A_So input and output signals**

Input(s)	Output(s)
S12_CI_D	TUG_AI_D
S12_CI_CK	TUG_AI_CK
S12_CI_FS	TUG_AI_FS
S12_CI_SSF	
P31s_TI_CK	
P31s_TI_FS	
P31s_TI_MFS	
TUG/S12_A_So_MI_Active	

NOTE 1: The TUG/S12_A_So functions can only be used in a P31s/SX_A_So compound function. It can not be used as a stand alone function.

Processes:

This function provides frequency justification and bitrate adaptation for a VC-12 signal, represented by a nominally $(140 \times 64 / 4) = 2\,240$ kbit/s information stream with a frequency accuracy within $\pm 4,6$ ppm and the related frame phase, to be multiplexed into a P31s signal via a TU-12.

NOTE 2: Degraded performance may be observed when interworking with SONET equipment having a ± 20 ppm network element clock source.

The (500 μ s) frame phase of the VC-12 is coded in the related TU-12 pointer. Frequency justification, if required, is performed by pointer adjustments. The accuracy of this coding process is specified below. Refer to annex A of EN 300 417-4-1 [11].

Frequency justification and bitrate adaptation: The function shall provide an elastic store (buffer) process. The data and frame start signals shall be written into the buffer under control of the associated input clock. The data and frame start signals shall be read out of the buffer under control of the P31s clock, frame position, and justification decision.

The justification decisions determine the phase error introduced by the TUG/S12_A_So function. The amount of this phase error can be measured at the physical interfaces by monitoring the TU-12 pointer actions. An example is given in clause A.2 of EN 300 417-4-1 [11].

Each justification decision results in a corresponding negative/positive justification action. Upon a positive justification action, the reading of 8 data bits shall be cancelled once and no data are written at the justification opportunity position V3+1 (see figure 79). Upon a negative justification action, an extra 8 data bits shall be read out once into the justification opportunity position V3.

NOTE 3: A requirement for maximum introduced phase error cannot be defined until a reference path is defined from which the requirements for network elements can be deduced. Such a requirement would also limit excessive phase error caused by pointer processors under fixed frequency offset conditions.

Buffer size: For further study.

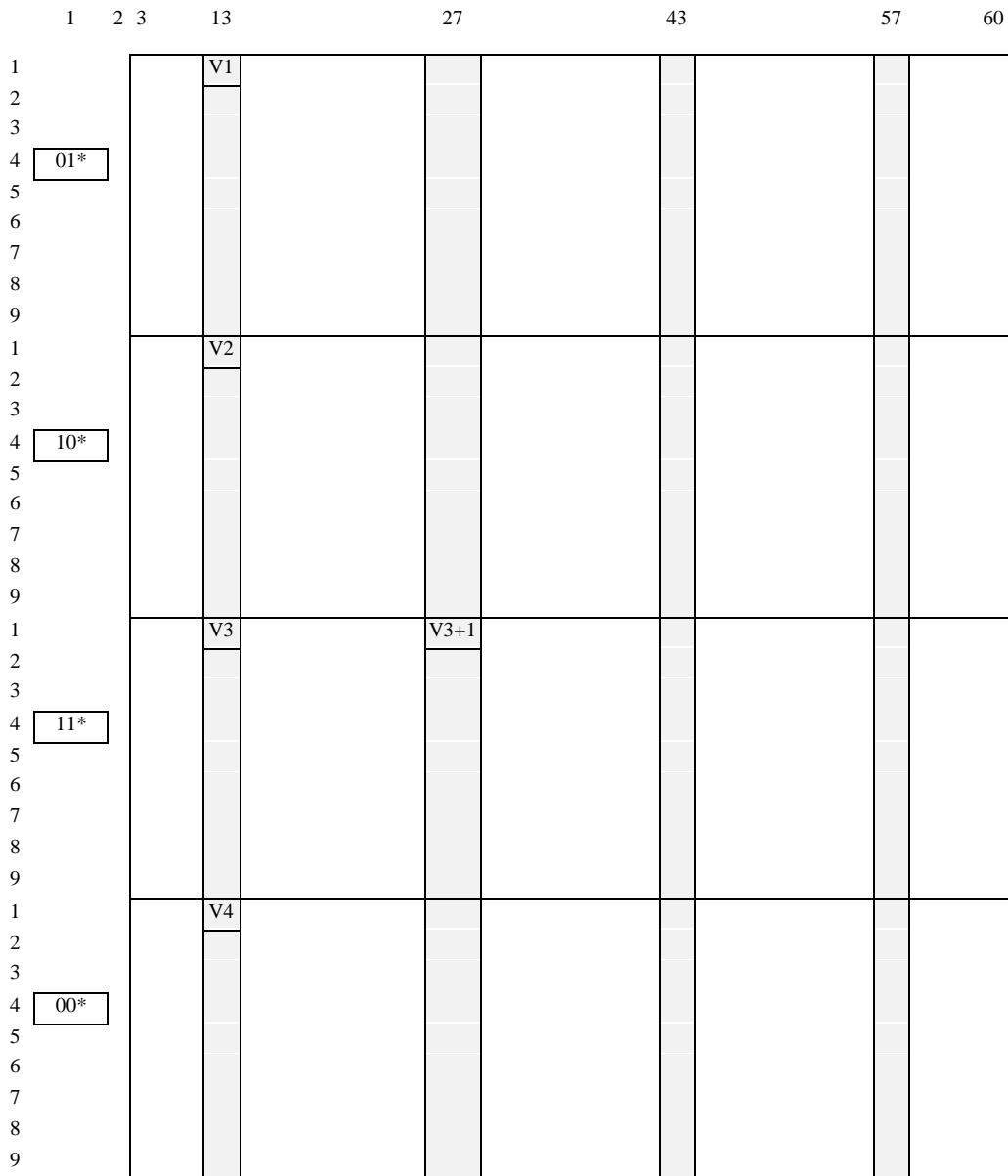

 indicates the 144 bytes belonging to the TU-12 (10)
 01*, 10*, 11*, and 00* indicate code value in bits MA[6-7]

Figure 79: TUG_AI_D/10 signal

The TU-12 pointer is carried in bytes V1 and V2 of payload specific OH per 500 μs multiframe (see figure 79). The TU-12 pointer is aligned in the P31s payload in fixed positions relative to the P31s frame and multiframe. The format of the TU-12 pointer and its location in the frame/multiframe are defined in ETS 300 337 [10].

V1, V2 - Pointer generation: The function shall generate the TU-12 pointer as is described in EN 300 417-1-1 [9], annex A: Pointer Generation. It shall insert the pointer in the appropriate V1, V2 positions with the SS field set to 10 to indicate TU-12.

NOTE 4: The byte V4 is undefined.

TU-12 timeslot: The adaptation source function has access to a specific TU-12 of the TUG access point. The TU-12 is defined by the parameter M (M=0 to 13).

Figure 73 shows that more than one adaptation source function exists in the TUG virtual sub-layer that can be connected to one TUG access point. For such case, a subset of these adaptation source functions is allowed to be activated together, but only one adaptation source function may have access to a specific TU timeslot. Access to the same TU timeslot by other adaptation source functions shall be denied.

Activation: The function shall access the access point when it is activated (MI_Active is true). Otherwise, it shall not access the access point.

Defects: none.

Consequent actions:

aAIS ← CI_SSF

On declaration of aAIS the function shall output an all-ONEs signal within 1 ms; on clearing of aAIS the function shall output normal data within 1 ms.

NOTE 5: If CI_SSF is not connected (when connected to a S12_TT_So), CI_SSF is assumed to be false.

Defect correlations: none.

Performance monitoring: none.

8.3.1.4 TUG to VC-11 layer adaptation source function TUG/S11*_A_So/M

Symbol:

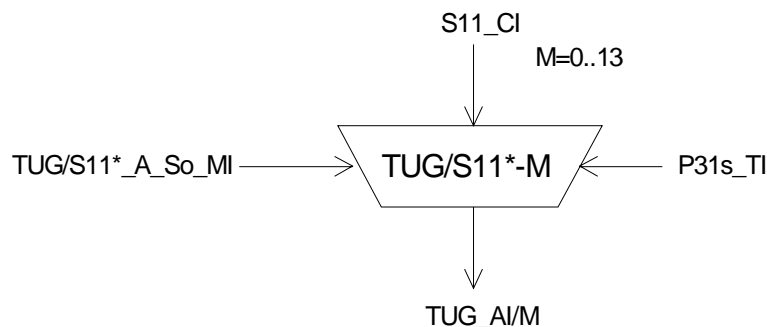

Figure 80: TUG/S11*_A_So symbol

Interfaces:

Table 51: TUG/S11*_A_So input and output signals

Input(s)	Output(s)
S11_CI_D	TUG_AI_D
S11_CI_CK	TUG_AI_CK
S11_CI_FS	TUG_AI_FS
S11_CI_SSF	
P31s_TI_CK	
P31s_TI_FS	
P31s_TLMFS	
TUG/S11*_A_So_MI_Active	

NOTE 1: The TUG/S11*_A_So functions can only be used in a P31s/SX*_A_So compound function. It can not be used as a stand alone function.

Processes:

This function provides frequency justification and bitrate adaptation for a VC-11 signal, represented by a nominally $(104 \times 64 / 4) = 1\,664$ kbit/s information stream with a frequency accuracy within $\pm 4,6$ ppm and the related frame phase, to be multiplexed into a VC-4 signal. The VC-11 is transported within a TU-12; 9 bytes of fixed stuff (see figure 81) are added per 125 μ s to the VC-11 as specified by ETS 300 147 [1] to map the VC-11 into the TU-12 payload (see note 2).

NOTE 2: Mapping a VC-11 into a TU-12 allows the VC-11 signal to be transported in a VC-12 based network (via S12_C and TUG/S12_A functions) and to non-intrusively monitor this VC-11 by means of a VC-12 non-intrusive monitor (S12m_TT_Sk). The TUG/S11*_A function will be used at the junction of VC-11 and VC-12 networks.

NOTE 3: Degraded performance may be observed when interworking with SONET equipment having a ± 20 ppm network element clock source.

The (500 μ s) frame phase of the VC-11 is coded in the related TU-12 pointer. Frequency justification, if required, is performed by pointer adjustments. The accuracy of this coding process is specified below. Refer to annex A of EN 300 417-4-1 [11].

Frequency justification and bitrate adaptation: The function shall provide an elastic store (buffer) process. The data and frame start signals shall be written into the buffer under control of the associated input clock. The data and frame start signals shall be read out of the buffer under control of the P31s clock, frame position, and justification decision.

The justification decisions determine the phase error introduced by the TUG/S11*_A_So function. The amount of this phase error can be measured at the physical interfaces by monitoring the TU-12 pointer actions. An example is given in clause A.2 of EN 300 417-4-1 [11].

Each justification decision results in a corresponding negative/positive justification action. Upon a positive justification action, the reading of 8 data bits shall be cancelled once and no data are written at the justification opportunity position V3+1 (see figure 81). Upon a negative justification action, an extra 8 data bits shall be read out once into the justification opportunity position V3.

NOTE 4: A requirement for maximum introduced phase error cannot be defined until a reference path is defined from which the requirements for network elements can be deduced. Such a requirement would also limit excessive phase error caused by pointer processors under fixed frequency offset conditions.

Buffer size: For further study.

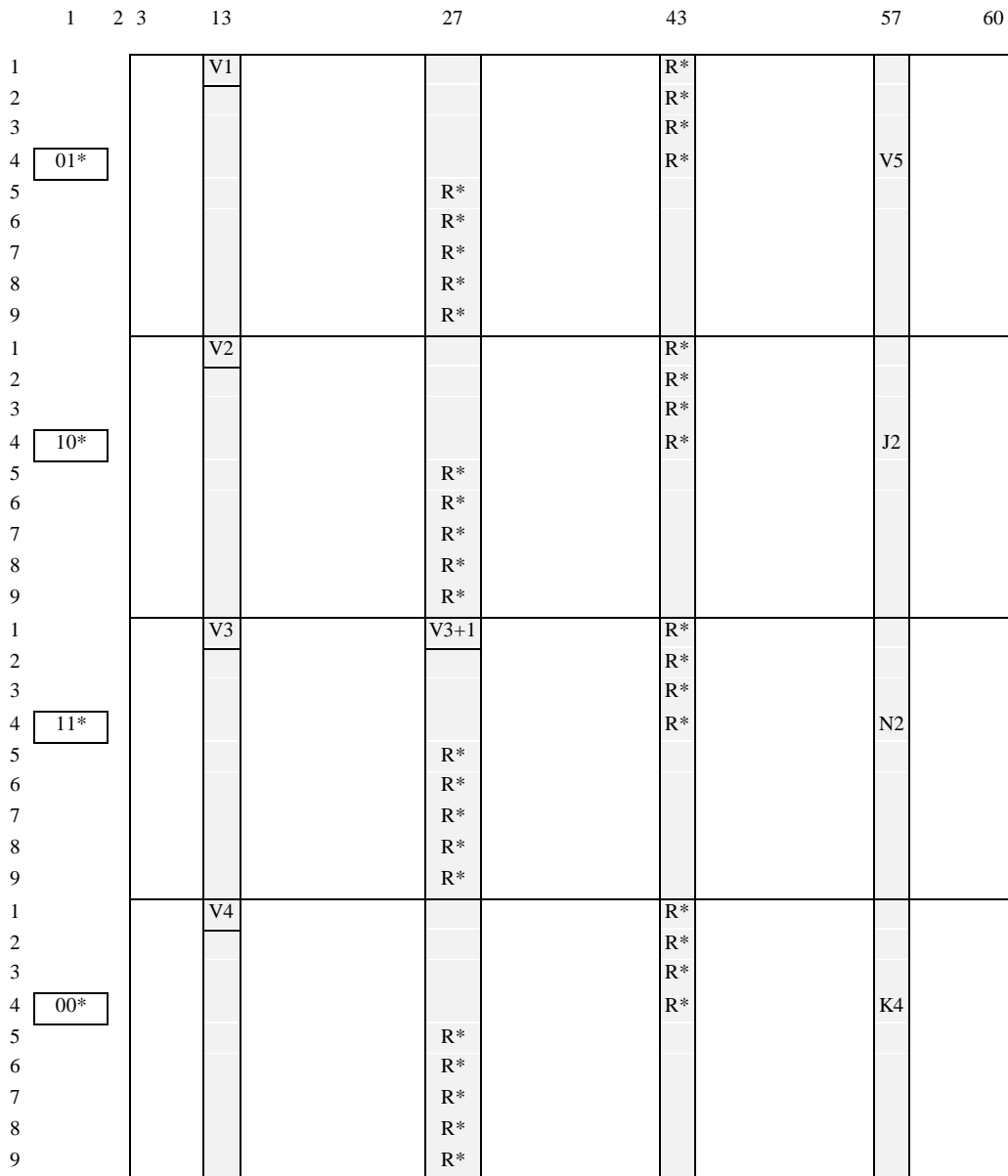

 indicates the 144 bytes belonging to the TU-12 (10)

01*, 10*, 11*, and 00* indicate code value in bits MA[6-7]

R* indicates fixed stuff with even parity

The positions of the V5, J2, N2, K4 and R* bytes is relative to the position of the VC-11 in the TU-12.

The start of the VC-11 (V5 byte) is defined by the TU-12 pointer.

Figure 81: TUG_AI_D/10 signal

The TU-12 pointer is carried in bytes V1 and V2 of payload specific OH per 500 μs multiframe (see figure 81). The TU-12 pointer is aligned in the P31s payload in fixed positions relative to the P31s frame and multiframe. The format of the TU-12 pointer and its location in the frame/multiframe are defined in ETS 300 337 [10].

V1, V2 - Pointer generation: The function shall generate the TU-12 pointer as is described in EN 300 417-1-1 [9], annex A: Pointer Generation. It shall insert the pointer in the appropriate V1, V2 positions with the SS field set to 10 to indicate TU-12.

NOTE 5: The byte V4 is undefined.

TU-12 timeslot: The adaptation source function has access to a specific TU-12 of the TUG access point. The TU-12 is defined by the parameter M (M=0 to 13).

Figure 73 shows that more than one adaptation source function exists in the TUG virtual sub-layer that can be connected to one TUG access point. For such case, a subset of these adaptation source functions is allowed to be activated together, but only one adaptation source function may have access to a specific TU timeslot. Access to the same TU timeslot by other adaptation source functions shall be denied.

Activation: The function shall access the access point when it is activated (MI_Active is true). Otherwise, it shall not access the access point.

Defects: none.

Consequent actions:

aAIS ← CI_SSF

On declaration of aAIS the function shall output an all-ONEs signal within 1 ms; on clearing of aAIS the function shall output normal data within 1 ms.

NOTE 6: If CI_SSF is not connected (when connected to a S11_TT_So), CI_SSF is assumed to be false.

Defect correlations: none.

Performance monitoring: none.

8.3.2 P31s layer to VC-12, VC-11 layer compound adaptation sink function P31s/SX_A_Sk

Symbol:

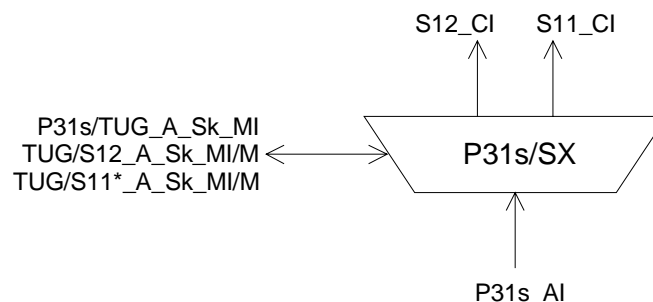

Figure 82: P31s/TUG_A_Sk symbol

Interfaces:

Table 52: P31s/TUG_A_Sk input and output signals

Input(s)	Output(s)
P31s_AI	P31s/TUG_A_Sk_MI
P31s/TUG_A_Sk_MI	maximum 14 outputs:
maximum 14 inputs:	S12_CI
TUG/S12_A_Sk_MI/M	TUG/S12_A_Sk_MI/M
maximum 14 inputs:	maximum 14 outputs:
TUG/S11*_A_Sk_MI/M	S11_CI
	TUG/S11*_A_Sk_MI/M

Processes:

The P31s/SX_A_Sk compound function provides adaptation from the P31s layer to the VC-12/11 layers. This process is performed by a combination of several atomic functions as shown in figure 83. The P31s/TUG_A_Sk function performs the P31s layer specific signal label and multiframe processing, while the TUG/S12_A_Sk and TUG/S11*_A_Sk functions perform the lower order VC specific frequency justification and bitrate adaptation. Each of these TUG/Sm_A_Sk functions is characterized by the parameter M, which define the number of the TU within the P31s the function has access to (TU numbering scheme as specified in ETS 300 337 [10], clause 5.3). According to the TUG multiplex structures supported by the NE, a variety of possible combinations of these TUG/Sm_A_Sk functions exists. Table 53 lists all possible TUG/Sm_A_Sk functions within a P31s/SX_A_Sk compound function.

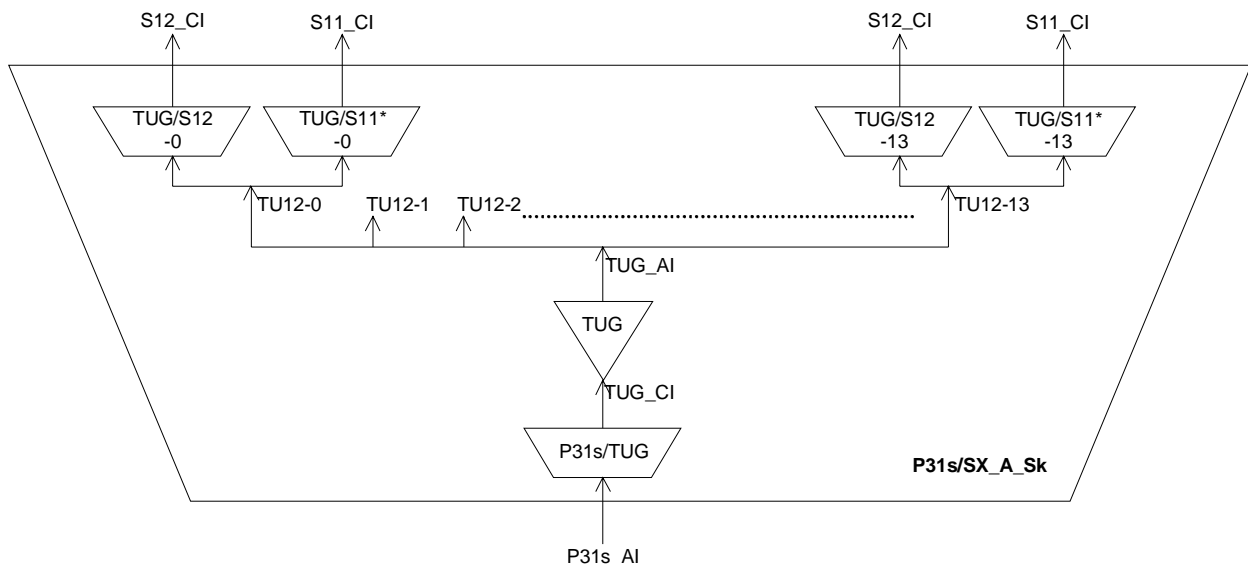

Figure 83: P31s/SX_A_Sk compound function with set of P31s/Sm_A_Sk atomic functions

Table 53: Possible TUG/Sm_A_Sk functions of a P31s/SX_A_Sk compound function

Atomic function	TU-12 number M
TUG/S12_A_Sk/M	0 to 13
TUG/S11*_A_Sk/M	0 to 13

For specific implementations only a subset of these TUG/Sm_A_Sk functions may be used (e.g. a terminal multiplexer with fixed 2 Mbit/s access has 14 TUG/S12_A_Sk functions). If a flexible TUG multiplex structure is supported, several TUG/Sm_A_Sk functions may have access to the same TU timeslot. In contradiction with the source direction, adaptation sink functions may be activated all together. This will presumably cause faults (e.g. cLOP) to be detected and reported. To prevent this an adaptation sink function can be deactivated. This is controlled by the equipment management function by activating/deactivating the functions according to the configured TUG multiplex structure.

NOTE 1: The P31s/TUG_A_Sk, TUG_T_Sk and TUG/Sm_A_Sk (m = 12, 11*) defined in the following clauses can only be used in a P31s/SX_A_Sk compound function. These functions can not be used as stand alone functions.

NOTE 2: The TUG is a virtual sub-layer only applicable in a P31s/SX_A compound function.

8.3.2.1 P31s layer to TUG adaptation sink function P31s/TUG_A_Sk

Symbol:

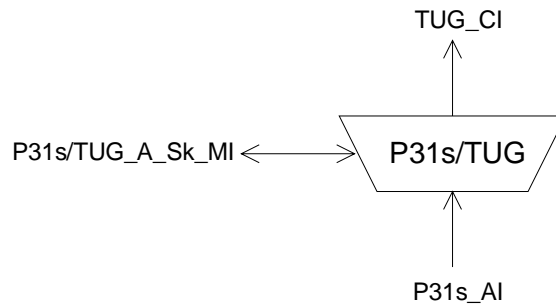

Figure 84: P31s/TUG_A_Sk symbol

Interfaces:

Table 54: P31s/TUG_A_Sk input and output signals

Input(s)	Output(s)
P31s_AI_D	TUG_CI_D
P31s_AI_CK	TUG_CI_CK
P31s_AI_FS	TUG_CI_FS
P31s_AI_TSF	TUG_CI_MFS
P31s/TUG_A_Sk_MI_Active	TUG_CI_SSF
	P31s/TUG_A_Sk_MI_cPLM
	P31s/TUG_A_Sk_MI_cLOM

NOTE 1: The P31s/TUG_A_Sk functions can only be used in a P31s/SX_A_Sk compound function. It can not be used as a stand alone function.

Processes:

The function monitors two payload specific signals (bits MA[3-5] and MA[6-7]) of the P31s POH.

MA[3-5]: The function shall compare the content of the accepted MA[3-5] bits with the expected value code "011" (TU-12 structure) as a check on consistency between the provisioning operation at each end. The application, acceptance and mismatch detection processes are described in EN 300 417-1-1 [9], clauses 7.2 and 8.1.2.

MA[6-7]: The function shall recover the 500 μ s (multi)frame start phase performing multi-frame alignment on bits 6 and 7 of byte MA. Out-of-multiframe (OOM) shall be assumed once when an error is detected in the MA bit 6 and 7 sequence. Multiframe alignment shall be assumed to be recovered, and the in-multiframe (IM) state shall be entered, when in four consecutive P31s frames an error free MA sequence is found.

Activation: The function shall perform the operation specified above when it is activated (MI_Active is true). Otherwise, it shall activate the SSF signal at its output and not report its status via the management point.

Defects:

The function shall detect for the dPLM defect as specified in EN 300 417-1-1 [9], clause 8.2.1.

If the multiframe alignment process is in the OOM state and the MA[6-7] multiframe is not recovered within X ms, a dLOM defect shall be declared. Once in a dLOM state, this state shall be exited when the multiframe is recovered (multiframe alignment process enter the IM state). X shall be a value in the range 1 to 5 (ms). X is not configurable.

Consequent actions:

aSSF \leftarrow dPLM or dLOM

Defect correlations:

cPLM \leftarrow dPLM and (not AI_TSF)

cLOM ← dLOM and (not AI_TSF) and (not dPLM)

NOTE 2: There may be another parallel adaptation function, e.g. P31s/SD_A_Sk that generate also cLOM. The EMF should take care that fLOM is reported only once.

Performance monitoring: none.

8.3.2.2 TUG termination sink function TUG_T_Sk

Symbol:

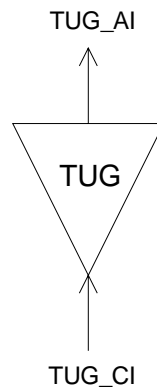

Figure 85: TUG_T_Sk symbol

Interfaces:

Table 55: TUG_T_Sk input and output signals

Input(s)	Output(s)
TUG_CI_D TUG_CI_CK TUG_CI_FS TUG_CI_SSF	TUG_AI_D TUG_AI_CK TUG_AI_FS TUG_AI_TSF
NOTE: The TUG_T_Sk functions can only be used in a P31s/SX_A_Sk compound function. It can not be used as a stand alone function.	

Processes: none.

Defects: none.

Consequent actions:

aTSF ← CI_SSF

Defect correlations: none.

Performance monitoring: none.

8.3.2.3 TUG to VC-12 layer adaptation sink function TUG/S12_A_Sk/M

Symbol:

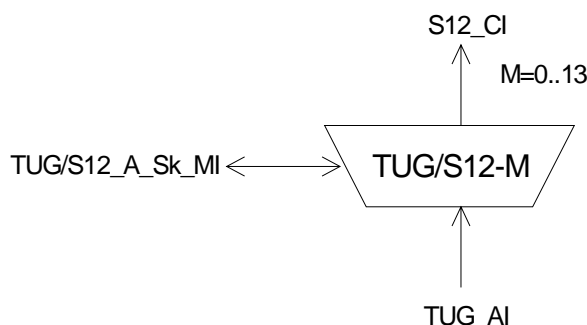

Figure 86: TUG/S12_A_Sk symbol

Interfaces:

Table 56: TUG/S12_A_Sk input and output signals

Input(s)	Output(s)
TUG_AI_D	S12_CI_D
TUG_AI_CK	S12_CI_CK
TUG_AI_FS	S12_CI_FS
TUG_AI_TSF	S12_CI_SSF
TUG/S12_A_Sk_MI_AIS_Reported	TUG/S12_A_Sk_MI_cLOP
TUG/S12_A_Sk_MI_Active	TUG/S12_A_Sk_MI_cAIS

NOTE: The TUG/S12_A_Sk functions can only be used in a P31s/SX_A_Sk compound function. It can not be used as a stand alone function.

Processes:

This function recovers VC-12 data with frame phase information from a TU-12.

V1, V2 - TU-12 pointer interpretation: The function shall perform TU-12 pointer interpretation as specified in annex B in EN 300 417-1-1 [9] to recover the VC-12 frame phase within a TU-12 of a P31s.

TU-12 timeslot: The adaptation sink function has access to a specific TU-12 of the TUG access point. The TU-12 is defined by the parameter M (M=0 to 13).

Figure 83 shows that more than one adaptation sink function exists in this TUG virtual sub-layer that can be connected to one TUG access point. In contradiction with the source direction, adaptation sink functions may be activated all together. This will presumably cause faults (e.g. cLOP) to be detected and reported. To prevent this an adaptation sink function can be deactivated.

Activation: The function shall perform the operation specified above when it is activated (MI_Active is true). Otherwise, it shall transmit the all-ONES signal at its output (CI_D) and not report its status via its management point.

Defects:

The function shall detect for dAIS and dLOP defect according the algorithm described under the pointer interpreter process in EN 300 417-1-1 [9], annex B, Pointer Interpretation.

Consequent actions:

- aAIS ← dAIS or dLOP or AI_TSF
- aSSF ← dAIS or dLOP or AI_TSF

On declaration of aAIS the function shall output all ONEs signal within 1 ms; on clearing of aAIS the function shall output the recovered data within 1 ms.

Defect correlations:

cAIS ← dAIS and (not AI_TSF) and AIS_Reported
 cLOP ← dLOP and (not AI_TSF)

It shall be an option to report AIS as a fault cause. This is controlled by means of the parameter AIS_Reported. The default shall be AIS_Reported = false.

Performance monitoring: none.

8.3.2.4 TUG to VC-11 layer adaptation sink function TUG/S11*_A_Sk/M

Symbol:

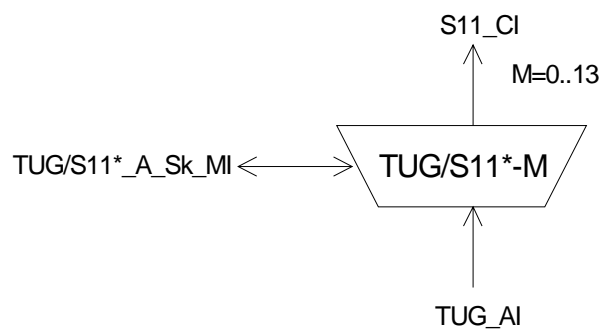

Figure 87: TUG/S11*_A_Sk symbol

Interfaces:

Table 57: TUG/S11*_A_Sk input and output signals

Input(s)	Output(s)
TUG_AI_D	S11_CI_D
TUG_AI_CK	S11_CI_CK
TUG_AI_FS	S11_CI_FS
TUG_AI_TSF	S11_CI_SSF
TUG/S11*_A_Sk_MI_AIS_Reported	TUG/S11*_A_Sk_MI_cLOP
TUG/S11*_A_Sk_MI_Active	TUG/S11*_A_Sk_MI_cAIS

NOTE: The TUG/S11*_A_Sk functions can only be used in a P31s/SX_A_Sk compound function. It can not be used as a stand alone function.

Processes:

This function recovers VC-11 data with frame phase information from a TU-12.

V1, V2 - TU-12 pointer interpretation: The function shall perform TU-12 pointer interpretation as specified in annex B in EN 300 417-1-1 [9] to recover the VC-12 frame phase within a TU-12 of a P31s.

TU-12 timeslot: The adaptation sink function has access to a specific TU-12 of the TUG access point. The TU-12 is defined by the parameter M (M=0 to 13).

Figure 83 shows that more than one adaptation sink function exists in this TUG virtual sub-layer that can be connected to one TUG access point. In contradiction with the source direction, adaptation sink functions may be activated all together. This will presumably cause faults (e.g. cLOP) to be detected and reported. To prevent this an adaptation sink function can be deactivated.

Activation: The function shall perform the operation specified above when it is activated (MI_Active is true). Otherwise, it shall transmit the all-ONES signal at its output (CI_D) and not report its status via its management point.

Defects:

The function shall detect for dAIS and dLOP defect according the algorithm described under the pointer interpreter process in EN 300 417-1-1 [9], annex B, Pointer Interpretation.

Consequent actions:

aAIS ← dAIS or dLOP or AI_TSF

aSSF ← dAIS or dLOP or AI_TSF

On declaration of aAIS the function shall output all ONES signal within 1 ms; on clearing of aAIS the function shall output the recovered data within 1 ms.

Defect correlations:

cAIS ← dAIS and (not AI_TSF) and AIS_Reported

cLOP ← dLOP and (not AI_TSF)

It shall be an option to report AIS as a fault cause. This is controlled by means of the parameter AIS_Reported. The default shall be AIS_Reported = false.

Performance monitoring: none.

8.3.3 P31s layer to P0s layer adaptation source P31s/P0s_A_So

Symbol:

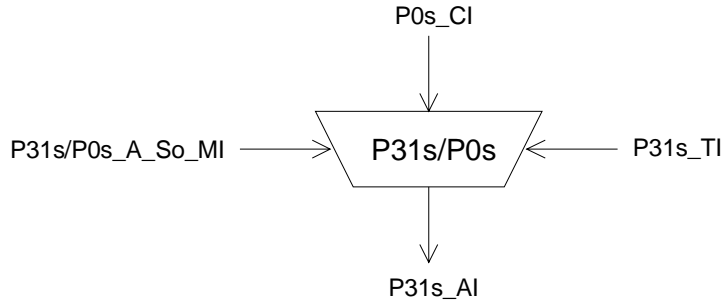

Figure 88: P31s/P0s_A_So symbol

Interfaces:

Table 58: P31s/P0s_A_So input and output signals

Input(s)	Output(s)
P0s_CI_D P0s_CI_CK P0s_CI_FS P31s_TI_CK P31s_TI_FS P31s/P0s_A_So_MI_Active	P31s_AI_D

Processes:

This function provides the multiplexing of a 64 kbit/s information stream into the P31s_AI using slip buffering. It takes P0s_CI, defined in ETS 300 166 [14] as an octet structured bit-stream with a synchronous bit rate of 64 kbit/s, present at its input and inserts it into the P31s POH byte GC as defined in ETS 300 337 [10] and depicted in figure 69.

NOTE: Any frequency deviation between the 64 kbit/s signal and the P31s signal leads to octet slips.

Frequency justification and bitrate adaptation: The function shall provide for an elastic store (slip buffer) process. The data signal shall be written into the buffer under control of the associated input clock. The data shall be read out of the buffer under control of the P31s clock, frame position (P31s_TI), and justification decisions.

Each justification decision results in a corresponding negative/positive justification (slip) action. Upon a positive justification (slip) action, the reading of one 64 kbit/s octet (8 bits) shall be cancelled once. Upon a negative justification (slip) action, the same 64 kbit/s octet (8 bits) shall be read out a second time.

Buffer size: The elastic store (slip buffer) shall accommodate at least 18 µs of wander without introducing errors.

Activation: The function shall access the access point when it is activated (MI_Active is true). Otherwise, it shall not access the access point.

Defects: none.

Consequent actions: none.

Defect correlations: none.

Performance monitoring: none.

8.3.4 P31s layer to P0s layer adaptation sink P31s/P0s_A_Sk

Symbol:

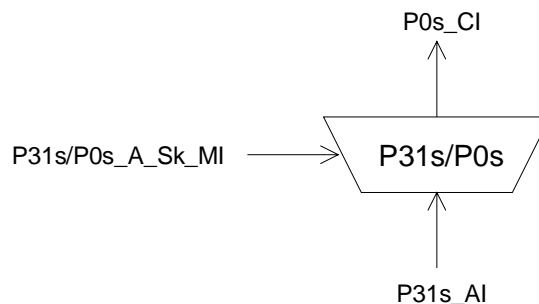

Figure 89: P31s/P0s_A_Sk symbol

Interfaces:

Table 59: P31s/P0s_A_Sk input and output signals

Input(s)	Output(s)
P31s_AI_D	P0s_CI_D
P31s_AI_CK	P0s_CI_CK
P31s_AI_FS	P0s_CI_FS
P31s_AI_TSF	
P31s/P0s_A_Sk_MI_Active	

Processes:

The function extracts the general communications channel byte GC from the P31s layer Characteristic Information. The recovered byte provides a 64 kbit/s channel for the client (user).

Data latching and smoothing process: The function shall provide a data latching and smoothing function. Each 8-bit octet received shall be written and latched into a data store under the control of the P31s signal clock. The eight data bits shall then be read out of the store using a nominal 64 kHz clock which may be derived directly from the incoming E31 signal clock. It should be noted that the divider is not an integer value.

Activation: The function shall perform the operation specified above when it is activated (MI_Active is true). Otherwise, it shall transmit the all-ONES signal at its output (CI_D).

Defects: none.

Consequent actions:

aAIS ← AI_TSF

On declaration of aAIS the function shall output an all-ONEs (AIS) signal - complying to the frequency limits for this signal (a bit rate in range 64 kbit/s \pm 100 ppm) - within 1 ms; on clearing of aAIS the function shall output normal data within 1 ms.

Defect correlations: none.

Performance monitoring: none.

8.3.5 P31s to V0x adaptation source P31s/V0x_A_So

Symbol:

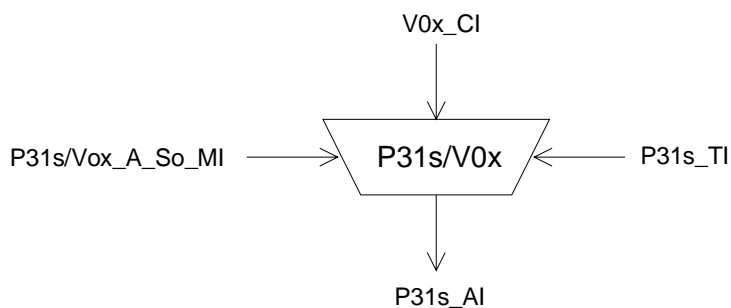

Figure 90: P31s/V0x_A_So symbol

Interfaces:

Table 60: P31s/V0x_A_So input and output signals

Input(s)	Output(s)
V0x_CI_D P31s_TI_CK P31s_TI_FS P31s/V0x_A_So_MI_Active	P31s_AI_D V0x_CI_CK

Processes:

This function multiplexes the V0x_CI data (64 kbit/s) into the byte location GC as defined in ETS 300 337 [10] and depicted in figure 69.

Activation: The function shall access the access point when it is activated (MI_Active is true). Otherwise, it shall not access the access point.

Defects: none.

Consequent actions: none.

Defect correlations: none.

Performance monitoring: none.

8.3.6 P31s to V0x adaptation sink P31s/V0x_A_Sk

Symbol:

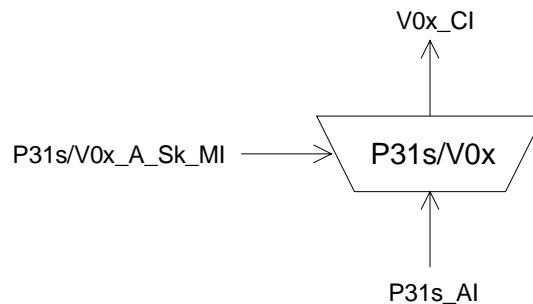

Figure 91: P31s/V0x_A_Sk symbol

Interfaces:

Table 61: P31s/V0x_A_Sk input and output signals

Input(s)	Output(s)
P31s_AI_D	V0x_CI_D
P31s_AI_CK	V0x_CI_CK
P31s_AI_FS	V0x_CI_SSF
P31s_AI_TSF	
P31s/V0x_A_Sk_MI_Active	

Processes:

This function separates user channel data from P31s Overhead (byte GC) as defined in ETS 300 337 [10] and depicted in figure 69.

Activation: The function shall perform the operation specified above when it is activated (MI_Active is true). Otherwise, it shall transmit the all-ONEs signal at its output (CI_D).

Defects: none.

Consequent actions:

aAIS ← AI_TSF

aSSF ← AI_TSF

On declaration of aAIS the function shall output an all-ONEs (AIS) signal - complying to the frequency limits for this signal (a bit rate in range 64 kbit/s ± X ppm) - within 1 ms; on clearing of aAIS the function shall output normal data within 1 ms. X is for further study.

Defect correlations: none.

Performance monitoring: none.

8.3.7 P31s to DCC adaptation source P31s/DCC_A_So

Symbol:

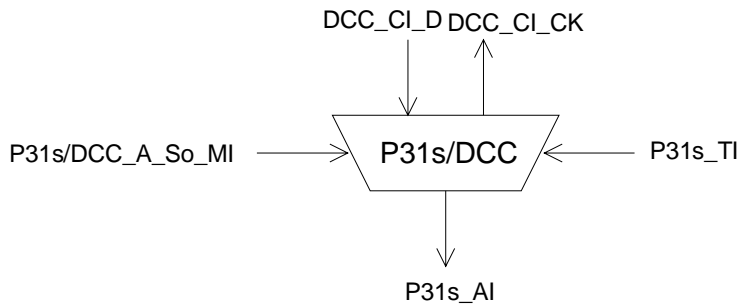

Figure 92: P31s/DCC_A_So symbol

Interfaces:

Table 62: P31s/DCC_A_Sk input and output signals

Input(s)	Output(s)
DCC_CI_D P31s_TI_CK P31s_TI_FS P31s/DCC_A_So_MI_Active	P31s_AI_D DCC_CI_CK

Processes:

The function multiplexes the DCC CI data (64 kbit/s) into the byte location GC as defined in ETS 300 337 [10] and depicted in figure 69.

NOTE: DCC transmission can be "disabled" when the matrix connection in the connected DCC_C function is removed.

Activation: The function shall access the access point when it is activated (MI_Active is true). Otherwise, it shall not access the access point.

Defects: none.

Consequent actions: none.

Defect correlations: none.

Performance monitoring: none.

8.3.8 P31s to DCC adaptation sink P31s/DCC_A_Sk

Symbol:

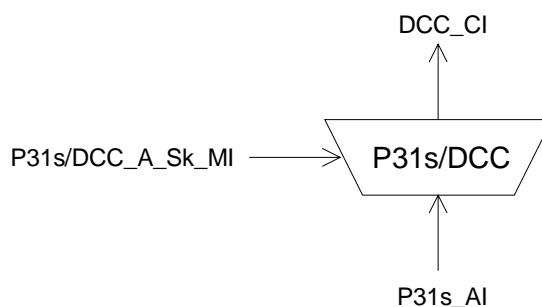

Figure 93: P31s/DCC_A_Sk symbol

Interfaces:**Table 63: P31s/DCC_A_Sk input and output signals**

Input(s)	Output(s)
P31s_AI_D	DCC_CI_D
P31s_AI_CK	DCC_CI_CK
P31s_AI_FS	DCC_CI_SSF
P31s_AI_TSF	
P31s/DCC_A_Sk_MI_Active	

Processes:

The function separates DCC data from P31s Overhead (byte GC) as defined in ETS 300 337 [10] and depicted in figure 69.

NOTE: DCC processing can be "disabled" when the matrix connection in the connected DCC_C function is removed.

Activation: The function shall perform the operation specified above when it is activated (MI_Active is true). Otherwise, it shall transmit the all-ONES signal at its output (CI_D).

Defects: none.

Consequent actions:

aSSF ← AI_TSF

Defect correlations: none.

Performance monitoring: none.

8.3.9 P31s to SD adaptation source P31s/SD_A_So

Refer to EN 300 417-6-1 [12].

8.3.10 P31s to SD adaptation sink P31s/SD_A_Sk

Refer to EN 300 417-6-1 [12].

8.3.11 P31s to ATM VP compound adaptation source P31s/Avp_A_So

Refer to EN 301 163 [13].

8.3.12 P31s to ATM VP compound adaptation sink P31s/Avp_A_Sk

Refer to EN 301 163 [13].

8.3.13 P31s Layer Clock adaptation source P31s-LC_A_So

Refer to EN 300 417-6-1 [12].

8.4 P31s layer monitoring functions

8.4.1 P31s non-intrusive monitoring function P31sm_TT_Sk

Symbol:

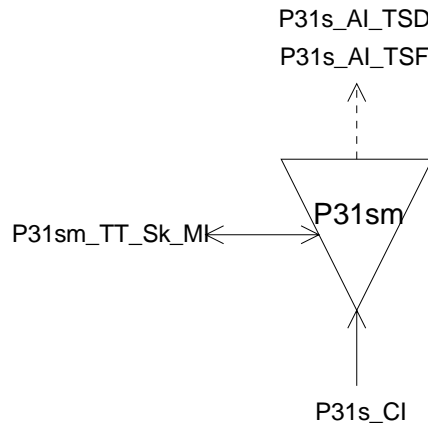

Figure 94: P31sm_TT_Sk symbol

Interfaces:

Table 64: P31sm_TT_Sk input and output signal

Input(s)	Output(s)
P31sm_CI_D	P31sm_AI_TSF
P31sm_CI_CK	P31sm_AI_TSD
P31sm_CI_FS	P31sm_TT_Sk_MI_cTIM
P31sm_CI_SSF	P31sm_TT_Sk_MI_cUNEQ
P31sm_TT_Sk_MI_TPmode	P31sm_TT_Sk_MI_cDEG
P31sm_TT_Sk_MI_SSF_Reported	P31sm_TT_Sk_MI_cRDI
P31sm_TT_Sk_MI_ExtI	P31sm_TT_Sk_MI_cSSF
P31sm_TT_Sk_MI_RDI_Reported	P31sm_TT_Sk_MI_ActI
P31sm_TT_Sk_MI_DEGTHR	P31sm_TT_Sk_MI_pN_EBC
P31sm_TT_Sk_MI_DEGM	P31sm_TT_Sk_MI_pF_EBC
P31sm_TT_Sk_MI_1second	P31sm_TT_Sk_MI_pN_DS
P31sm_TT_Sk_MI_TIMdis	P31sm_TT_Sk_MI_pF_DS

NOTE 1: This non-intrusive monitor trail termination sink function has no associated source function.

Processes:

This function monitors for 34 Mbit/s frame errors and recovers the trail termination status as defined in ETS 300 337 [10]. It extracts the payload independent overhead bytes EM, TR, MA bits 1, 2 from the P31sm layer Characteristic information:

EM: Even bit parity (BIP-8) shall be computed for each bit n of every byte of the preceding frame and compared with bit n of EM recovered from the current frame ($n=1$ to 8 inclusive). A difference between the computed and recovered EM values shall be taken as evidence of one or more errors (nN_B) in the computation block.

TR: The 16 byte Trail Trace Identifier (TTI) shall be recovered from the TR byte and shall be made available for network management purposes. The application and the acceptance and mismatch detection process shall be performed as described in the EN 300 417-1-1 [9], clauses 7.1 and 8.2.1.3.

The trace identifier process in this function is required to support "mode 1" (EN 300 417-1-1 [9], clause 7.1) only. "Transmission and Multiplexing (TM); Generic requirements of transport functionality of equipment; Part 1-1: Generic processes and performance" P31s connection equipment does not exist.

MA[1-2]: The relevant information carried in the MA byte (RDI in bit 1, REI in bit 2) shall be extracted to enable single ended maintenance of a bi-directional Trail. The REI (nF_B) shall be used to monitor the error performance of the reverse direction of transmission; the RDI provides information as to the status of the remote receiver. A "1" indicates a RDI state, while a "0" indicates the normal working state. The application process shall be performed as specified in EN 300 417-1-1 [9], clauses 7.4.2 (REI), 7.4.11 and 8.2 (RDI).

MA[3-5]: The information in the signal label bits shall be extracted to allow unequipped P31s and P31s-AIS defect detection.

Defects:

The detection and removal conditions and processes for dUNEQ, dDEG, dRDI and dTIM are described in EN 300 417-1-1 [9], clause 8.2.1 with the condition "aSSF" read as "aSSF or P31s dAIS". To use the function within e.g. a tandem connection (see note 2), it shall be possible to disable the trace id mismatch detection (TIMdis).

NOTE 2: Presumably, in such case the Trace Id. will be unknown to the tandem connection operator.

P31s AIS:

The function shall detect for an AIS condition by monitoring the P31s PSL for code "111". If 5 consecutive frames contain the "111" pattern in bits 3 to 5 of the MA byte a dAIS defect shall be detected. dAIS shall be cleared if in 5 consecutive frames any pattern other than the "111" is detected in bits 3 to 5 of the MA byte.

Consequent actions:

aTSF ← CI_SSF or dAIS or dUNEQ or dTIM

aTSD ← dDEG

Defect correlations:

cUNEQ ← MON and dUNEQ

cTIM ← MON and dTIM (and not dUNEQ)

cDEG ← MON and dDEG and (not dUNEQ) and (not dTIM)

cRDI ← MON and dRDI and (not dTIM) and (not dUNEQ) and RDI_Reported

cSSF ← MON and (CI_SSF or dAIS) and SSF_Reported

It shall be an option to report SSF as a fault cause. This is controlled by means of the parameter SSF_Reported. The default shall be SSF_Reported = false.

It shall be an option to report RDI as a fault cause. This is controlled by means of the parameter RDI_Reported. The default shall be RDI_Reported = false.

Performance monitoring:

The performance monitoring process shall be performed as specified in EN 300 417-1-1 [9], clauses 8.2.4 to 8.2.7.

pN_DS ← aTSF or dEQ

pF_DS ← dRDI

pN_EBC ← ΣnN_B

pF_EBC ← ΣnF_B

NOTE 3: pF_DS/pF_EBC represent the performance of the total trail while pN_DS/pN_EBC represents only part of the trail up to the point of the non-intrusive monitor.

8.5 P31s layer trail protection functions

For further study.

8.6 P31s tandem connection sublayer functions

8.6.1 P31s tandem connection trail termination source function (P31sD_TT_So)

Symbol:

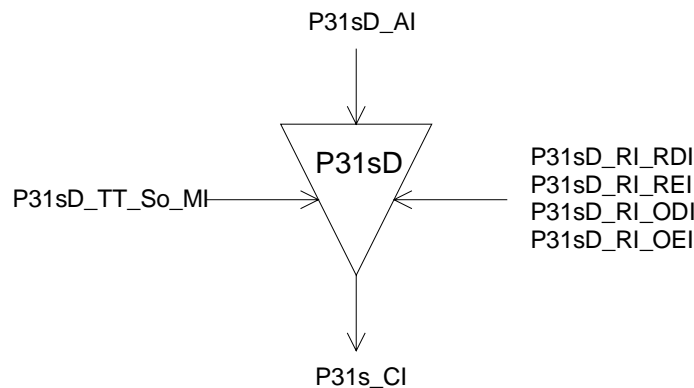

Figure 95: P31sD_TT_So symbol

Interfaces:

Table 65: P31sD_TT_So input and output signals

Input(s)	Output(s)
P31sD_AI_D	P31s_CI_D
P31sD_AI_CK	P31s_CI_CK
P31sD_AI_FS	P31s_CI_FS
P31sD_AI_SF	
P31sD_RI_RDI	
P31sD_RI_REI	
P31sD_RI_ODI	
P31sD_RI_OEI	
P31sD_TT_So_MI_TxTI	

Processes:

NR[8][73] (see note 1): The function shall insert the TC RDI code within 20 ms after the RDI request generation (RI_RDI) in the tandem connection trail termination sink function. It ceases TC RDI code insertion within 20 ms after the TC RDI request has cleared.

NOTE 1: NR[x][y] refers to bit x (x = 7,8) of byte NR in frame y (y=1 to 76) of the 76 frame multiframe.

NR[5]: The function shall insert the RI_REI value in the REI bit within 20 ms.

NR[7][74]: The function shall insert the ODI code within 20 ms after the ODI request generation (aODI) in the tandem connection trail termination sink function. It ceases ODI code insertion within 20 ms after the ODI request has cleared.

NR[6]: The function shall insert the RI_OEI value in the OEI bit within 20 ms.

NR[7-8]: The function shall insert in the multiframed NR[7-8] channel:

- the Frame Alignment Signal (FAS) "1111 1111 1111 1110" in FAS bits in frames 1 to 8;

- the TC trace identifier, received via MI_TxTI, in the TC-TI bits in frames 9 to 72;
- the TC RDI (NR[8][73]) and ODI (NR[7][74]) signals; and
- "0" in the six reserved bits in frames 73 to 76.

NR[1-4]: Even BIP-8 shall be computed for each bit n of every byte of the preceding incoming P31s frame (P31s_AI) including EM byte and compared with byte EM recovered from the current frame. A difference between the computed and recovered BIP-8 values shall be taken as evidence of one or more errors in the computation block, and shall be inserted in bits 1 to 4 of byte NR (see figure 96, table 66). If AI_SF is true, code "1110" shall be inserted in bits 1 to 4 of byte NR instead of the number of incoming BIP-8 violations.

NOTE 2: Zero BIP-8 violations detected in the tandem connection incoming signal is coded with a non-all-ZEROS IEC code. This allows this IEC field to be used at the TC tail end as differentiator between TC incoming unequipped VC and unequipped TC.

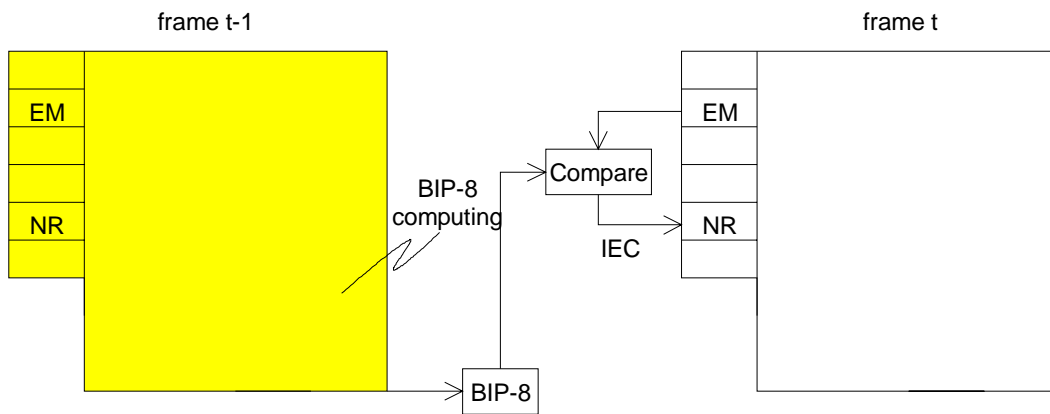

Figure 96: TC IEC computing and insertion

Table 66: IEC code generation

Number of BIP-8 violations	NR[1]	NR[2]	NR[3]	NR[4]
1	0	0	0	1
2	0	0	1	0
3	0	0	1	1
4	0	1	0	0
5	0	1	0	1
6	0	1	1	0
7	0	1	1	1
8	1	0	0	0
0	1	0	0	1

EM: The function shall compensate the P31s BIP8 (in EM) according the following rule:

Since the BIP-8 parity check is taken over the P31s (including NR), writing into NR at the P31sD_TT_So will affect the P31s path parity calculation. Unless this is compensated for, a device which monitors P31s path parity within the Tandem Connection (e.g., a non-intrusive monitor) may incorrectly count errors. The BIP-8 parity bits should always be consistent with the current state of the P31s. Therefore, whenever NR is written, BIP-8 shall be modified to compensate for the change in the NR value. Since the BIP-8 value in a given frame reflects a parity check over the previous frame (including the BIP-8 bits in that frame), the changes made to the BIP-8 bits in the previous frame shall also be considered in the compensation of BIP-8 for the current frame. Therefore, the following equation shall be used for BIP-8 compensation:

$$EM[i]'(t) = EM[i](t-1) \oplus EM[i]'(t-1) \oplus NR[i](t-1) \oplus NR[i]'(t-1) \oplus EM[i](t)$$

Where:

- $EM[i]$ = the existing $EM[i]$ value in the incoming signal;
- $EM[i]'$ = the new (compensated) $EM[i]$ value;
- $NR[i]$ = the existing $NR[i]$ value in the incoming signal;
- $NR[i]'$ = the new value written into the $NR[i]$ bit;
- \oplus = exclusive OR operator;
- t = the time of the current frame;
- $t-1$ = the time of the previous frame.

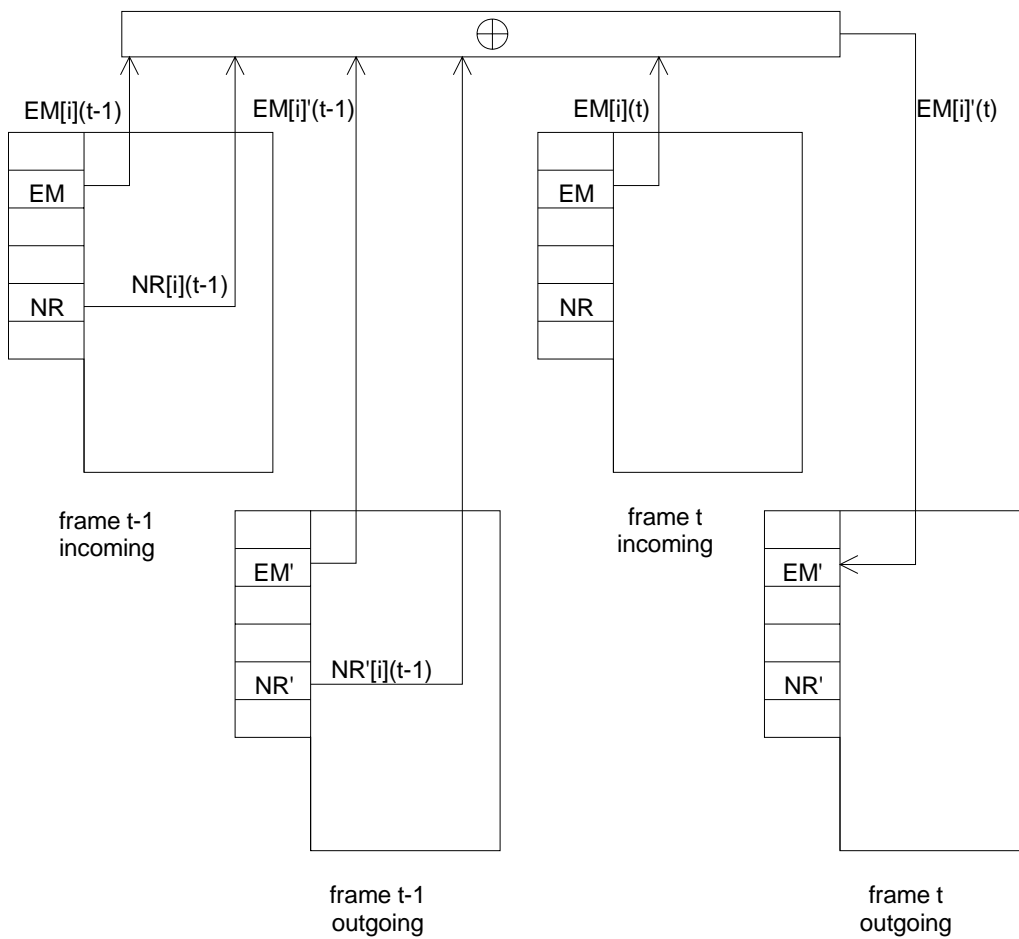

Figure 97: $EM[i]$, $i=1$ to 8 compensating process

Defects:	none.
Consequent actions:	none.
Defect correlations:	none.
Performance monitoring:	none.

8.6.2 P31s tandem connection trail termination sink function (P31sD_TT_Sk)

Symbol:

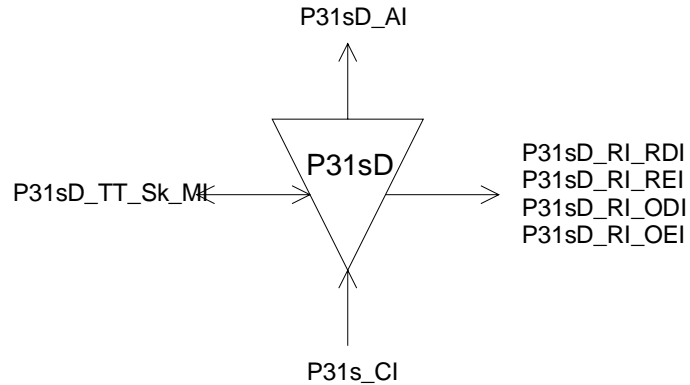

Figure 98: P31sD_TT_Sk symbol

Interfaces:

Table 67: P31sD_TT_Sk input and output signals

Input(s)	Output(s)
P31s_CI_D	P31sD_AI_D
P31s_CI_CK	P31sD_AI_CK
P31s_CI_FS	P31sD_AI_FS
P31s_CI_SSF	P31sD_AI_TSF
P31sD_TT_Sk_MI_ExtI	P31sD_AI_TSD
P31sD_TT_Sk_MI_AIS_Reported	P31sD_AI_OSF
P31sD_TT_Sk_MI_SSF_Reported	P31sD_TT_Sk_MI_cLTC
P31sD_TT_Sk_MI_RDI_Reported	P31sD_TT_Sk_MI_cTIM
P31sD_TT_Sk_MI_ODI_Reported	P31sD_TT_Sk_MI_cUNEQ
P31sD_TT_Sk_MI_TIMdis	P31sD_TT_Sk_MI_cDEG
P31sD_TT_Sk_MI_DEGM	P31sD_TT_Sk_MI_cRDI
P31sD_TT_Sk_MI_DEGTHR	P31sD_TT_Sk_MI_cSSF
P31sD_TT_Sk_MI_1second	P31sD_TT_Sk_MI_cODI
P31sD_TT_Sk_MI_TPmode	P31sD_TT_Sk_MI_cIncAIS
	P31sD_TT_Sk_MI_AcTI
	P31sD_RI_RDI
	P31sD_RI_REI
	P31sD_RI_ODI
	P31sD_RI_OEI
	P31sD_TT_Sk_MI_pN_EBC
	P31sD_TT_Sk_MI_pF_EBC
	P31sD_TT_Sk_MI_pN_DS
	P31sD_TT_Sk_MI_pF_DS
	P31sD_TT_Sk_MI_pON_EBC
	P31sD_TT_Sk_MI_pOF_EBC
	P31sD_TT_Sk_MI_pON_DS
	P31sD_TT_Sk_MI_pOF_DS

Processes:

TC EDC violations: Even bit parity shall be computed for each bit n of every byte of the preceding P31s and compared with bit n of EM recovered from the current frame (n=1 to 8 inclusive). A difference between the computed and recovered EM values shall be taken as evidence of one or more errors in the computation block (nON_B). The magnitude (absolute value) of the difference between this calculated number of errors and the number of errors written into the IEC (see table 68) at the trail termination source shall be used to determine the error performance of the tandem connection for each transmitted P31s (see figure 99). If this magnitude of the difference is one or more, an errored TC block is detected (nN_B). If one or more errors were detected in the computation block, an errored P31s block (nON_B) shall be declared.

NOTE 1: The EM data and the IEC read in the current frame both apply to the previous frame.

Table 68: IEC code interpretation

NR[1]	NR[2]	NR[3]	NR[4]	IEC code interpretation
0	0	0	0	0 errors
0	0	0	1	1 error
0	0	1	0	2 errors
0	0	1	1	3 errors
0	1	0	0	4 errors
0	1	0	1	5 errors
0	1	1	0	6 errors
0	1	1	1	7 errors
1	0	0	0	8 errors
1	0	0	1	0 errors
1	0	1	0	0 errors
1	0	1	1	0 errors
1	1	0	0	0 errors
1	1	0	1	0 errors
1	1	1	0	0 errors
1	1	1	1	0 errors

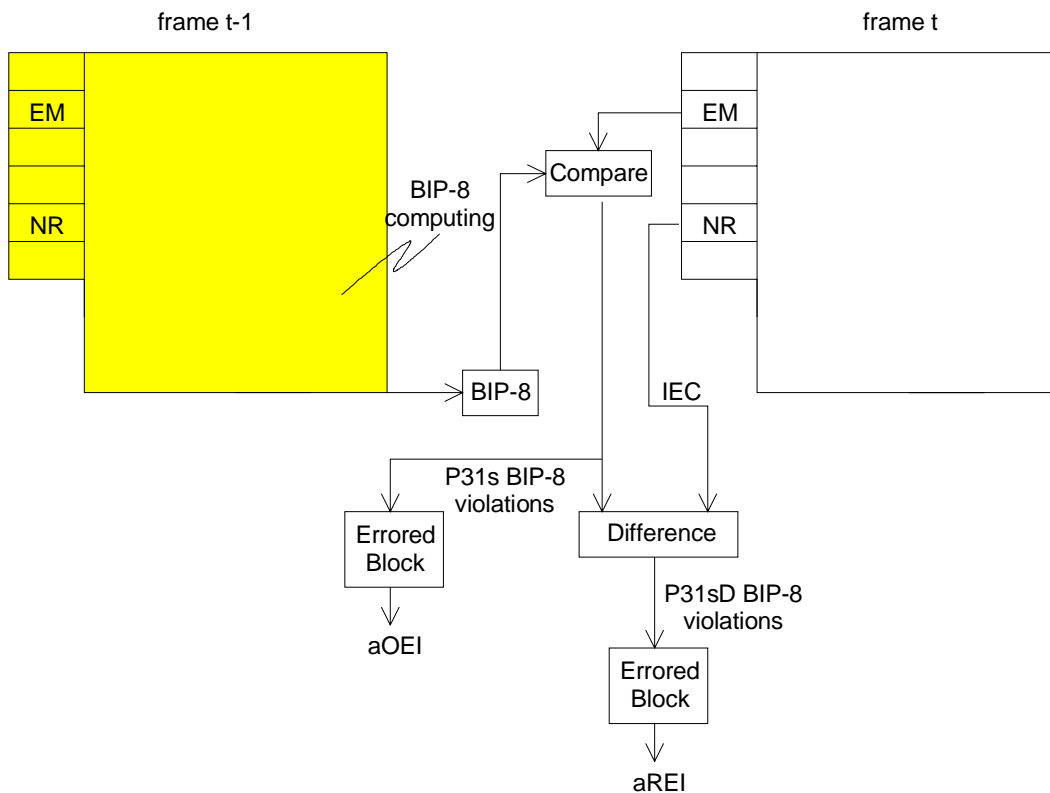

Figure 99: P31sD and P31s BIP-8 computing and comparison

NR[1-4]: The function shall extract the Incoming Error Code (IEC). It shall accept the received code without further processing.

NR[7-8][9-72]: The Received Trail Trace Identifier RxTI shall be recovered from the tandem connection trail trace identifier overhead and shall be made available as AcTI for network management purposes. The application and acceptance process shall be performed as specified in EN 300 417-1-1 [9], clauses 7.1 and 8.2.1.3. The mismatch detection process shall be as specified below.

The trace identifier process in this function is required to support "mode 1" (EN 300 417-1-1 [9], clause 7.1) operation only. "Old" tandem connection equipment does not exist.

NR[1-4]: The function shall extract the Incoming AIS code.

NR[5], NR[8][73]: The information carried in the REI, RDI bits in byte NR shall be extracted to enable single ended maintenance of a bi-directional tandem connection Trail. The REI (nF_B) shall be used to monitor the error performance of the other direction of transmission, and the RDI shall be used to provide information as to the status of the remote receiver. A "1" indicates a Remote Defect Indication state, while a "0" indicates the normal, working state. The application process shall be performed as specified in EN 300 417-1-1 [9], clauses 7.4.2 (REI), 7.4.11 and 8.2 (RDI).

NR[6], NR[7][74]: The information carried in the OEI, ODI bits in byte NR shall be extracted to enable single ended (intermediate) maintenance of a the P31s egressing the tandem connection Trail. The OEI (nOF_B) shall be used to monitor the error performance of the other direction of transmission, and the ODI shall be used to provide information as to the status of the remote receiver. A "1" indicates a Outgoing Defect Indication state, while a "0" indicates the normal, working state. The application process shall be performed equivalent to the remote maintenance case, as specified in EN 300 417-1-1 [9], clauses 7.4.2 (REI/OEI), 7.4.11 and 8.2 (RDI/ODI).

NR[7-8] - Multiframe alignment: The function shall perform a multiframe alignment on bits 7 and 8 of byte NR to recover the TTI, RDI, and ODI signals transported within the multiframe bits. The multiframe alignment shall be found by searching for the pattern "1111 1111 1111 1110" within the bits 7 and 8 of byte NR. The signal shall be continuously checked with the presumed multiframe start position for the alignment.

Frame alignment is deemed to have been lost (entering Out Of Multiframe (OOM) state) when two consecutive FAS are detected in error (i.e. ≥ 1 error in each FAS);

Frame alignment is deemed to have been recovered (entering In Multiframe (IM) state) when one non-errored FAS is found.

NR: The function shall terminate NR channel by inserting an all-ZEROs pattern.

EM: The function shall compensate the P31s BIP8 in byte EM according the algorithm defined in P31sD_TT_So.

Defects:

TC Unequipped (dUNEQ):

The function shall detect for an unequipped Tandem Connection (UNEQ) condition by monitoring byte NR for code "00000000". The unequipped defect (dUNEQ) shall be detected if five consecutive P31s frames contain the "0000 0000" pattern in byte NR. The dUNEQ defect shall be cleared if in five consecutive NR frames any pattern other than the "0000 0000" is detected in byte NR.

TC Loss of Tandem Connection (dLTC):

The function shall detect for the presence/absence of the tandem connection overhead in the byte NR by evaluating the multiframe alignment signal in bits 7 and 8 of byte NR. The loss of tandem connection defect (dLTC) shall be detected if the multiframe alignment process is in the OOM state. The dLTC shall be cleared if the multiframe alignment process is in the IM state.

TC Connectivity (Trace Identifier) (dTIM):

The function shall detect for a TC mis-connection condition by monitoring the TC trace identifier. The Trace Identifier Mismatch defect (dTIM) shall be detected and cleared within a maximum period of 1 s in the absence of bit errors.

The defect detection process and its operation during the presence of bit errors is for further study.

The defect shall be suppressed during the receipt of SSF.

It shall be possible to disable the trace identifier mismatch defect detection (TIMdis).

TC Signal Degrade (dDEG):

The function shall detect for a TC signal degrade defect condition by monitoring for TC BIP-8 violations. The algorithm shall be according clause 8.2.1.4 in EN 300 417-1-1 [9].

TC Remote Defect (dRDI):

The function shall detect for a TC remote defect indication defect condition by monitoring the TC RDI signal. The algorithm shall be according clause 8.2.1.5 in EN 300 417-1-1 [9].

TC Remote Outgoing P31s Defect (dODI):

The function shall detect for a TC remote outgoing P31s defect indication defect condition by monitoring the TC ODI signal. The algorithm shall be according clause 8.2.1.5 in EN 300 417-1-1 [9].

Incoming AIS (dIncAIS):

The function shall detect for a tandem connection incoming AIS condition by monitoring the IEC bits in byte NR for code "1110". If 5 consecutive frames contain the "1110" pattern in the IEC bits a dIncAIS defect shall be detected. dIncAIS shall be cleared if in 5 consecutive frames any pattern other than the "1110" is detected in the IEC bits.

NOTE 2: Bits 1 to 4 of byte NR support two applications: conveying the incoming error information (table 68) and conveying the incoming AIS information to the TC tail end. Codes 0000 to 1101, 1111 represent IncAIS is false, code 1110 represents IncAIS is true.

Consequent actions:

The function shall perform the following consequent actions (refer to clause 8.2.2 in EN 300 417-1-1 [9]):

aAIS	←	dUNEQ or dTIM or dLTC
aTSF	←	CI_SSF or dUNEQ or dTIM or dLTC
aTSD	←	dDEG
aRDI	←	CI_SSF or dUNEQ or dTIM or dLTC
aREI	←	nN_B
aODI	←	CI_SSF or dUNEQ or dTIM or dIncAIS or dLTC
aOEI	←	nON_B
aOSF	←	CI_SSF or dUNEQ or dTIM or dLTC or dIncAIS

The function shall insert the all-ONEs (AIS) signal within 250 μs after AIS request generation (aAIS), and cease the insertion within 250 μs after the AIS request has cleared.

Defect correlations:

The function shall perform the following defect correlations (refer to clause 8.2.3 in EN 300 417-1-1 [9]):

cUNEQ	←	MON and dUNEQ
cLTC	←	MON and (not dUNEQ) and dLTC
cTIM	←	MON and (not dUNEQ) and (not dLTC) and dTIM
cDEG	←	MON and (not dTIM) and (not dLTC) and dDEG
cSSF	←	MON and CI_SSF and SSF_reported
cRDI	←	MON and (not dUNEQ) and (not dTIM) and (not dLTC) and dRDI and RDI_Reported
cODI	←	MON and (not dUNEQ) and (not dTIM) and (not dLTC) and dODI and ODI_Reported
cIncAIS	←	MON and dIncAIS and (not CI_SSF) and (not dLTC) and (not dTIM) and AIS_reported

It shall be an option to report SSF as a fault cause. This is controlled by means of the parameter SSF_Reported. The default shall be SSF_Reported = false.

It shall be an option to report RDI as a fault cause. This is controlled by means of the parameter RDI_Reported. The default shall be RDI_Reported = false.

It shall be an option to report ODI as a fault cause. This is controlled by means of the parameter ODI_Reported. The default shall be ODI_Reported = false.

Performance monitoring:

The following TC error performance parameters shall be counted for each 1-second period (refer to clauses 8.2.4 to 8.2.7 in EN 300 417-1-1 [9]):

- pN_DS ← aTSF or dEQ
- pF_DS ← dRDI
- pN_EBC ← ΣnN_B
- pF_EBC ← ΣnF_B
- pON_DS ← aODI or dEQ
- pOF_DS ← dODI
- pON_EBC ← ΣnON_B
- pOF_EBC ← ΣnOF_B

pN_EBC and pN_DS do not represent the actual performance monitoring support within an equipment. For that, these pN_DS/pN_EBC signals shall be connected to performance monitoring functions within the element management function. Similar for the far-end signals pF_EBC and pF_DS and for pON_EBC/pON_DS, pOF_EBC/pOF_DS.

8.6.3 P31s tandem connection to p31s adaptation source function (P31sD/P31s_A_So)

Symbol:

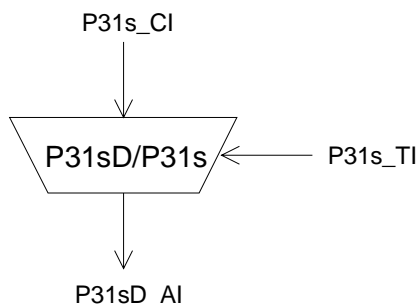

Figure 100: P31sD/P31s_A_So symbol

Interfaces:

Table 69: P31sD/P31s_A_So input and output signals

Input(s)	Output(s)
P31s_CI_D	P31sD_AI_D
P31s_CI_CK	P31sD_AI_CK
P31s_CI_FS	P31sD_AI_FS
P31s_CI_SSF	P31sD_AI_SF
P31s_TI_CK	

Processes:

NOTE 1: The function has no means to verify the existence of a tandem connection within the incoming signal. Nested tandem connections are not supported.

The function shall replace the incoming P31s signal (P31s_CI) by a local generated P31s frame with valid FA1 and FA2 bytes and all ONES for all other bytes (i.e. enter "holdover") if an all-ONES (AIS) P31s is received (i.e. if CI_SSF is TRUE).

NOTE 2: The local frame start is generated with the P31s_TI timing.

Defects: none.

Consequent actions:

AI_SF ← CI_SSF

Defect correlations: none.

Performance monitoring: none.

8.6.4 P31s tandem connection to p31s adaptation sink function (P31sD/P31s_A_Sk)

Symbol:

Figure 101: P31sD/P31s_A_Sk symbol

Interfaces:

Table 70: P31sD/P31s_A_Sk input and output signals

Input(s)	Output(s)
P31sD_AI_D	P31s_CI_D
P31sD_AI_CK	P31s_CI_CK
P31sD_AI_FS	P31s_CI_FS
P31sD_AI_OSF	P31s_CI_SSF

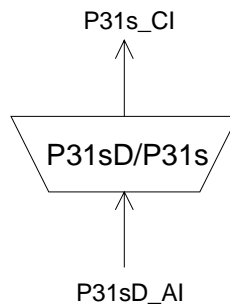
Processes:

The function shall restore the invalid frame start condition (i.e. output aSSF = true) if that existed at the ingress of the tandem connection.

NOTE: In addition, the invalid frame start condition is activated on a tandem connection connectivity defect condition that causes all-ONES (AIS) insertion in the P31sD_TT_Sk.

Defects: none.

Consequent actions:

aAIS ← AI_OSF

aSSF ← AI_OSF

The function shall insert the all-ONES (AIS) signal within 250 μs after AIS request generation (aAIS), and cease the insertion within 250 μs after the AIS request has cleared.

Defect correlations: none.

Performance monitoring: none.

8.6.5 P31s tandem connection non-intrusive trail termination sink function (P31sDm_TT_Sk)

Symbol:

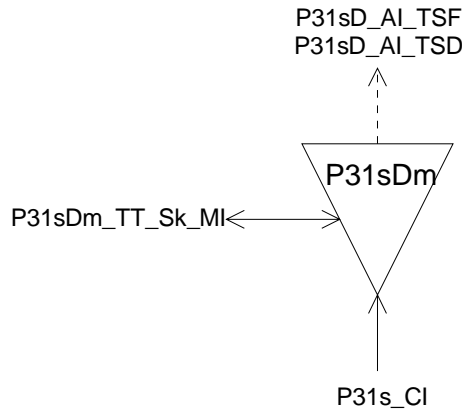

Figure 102: P31sDm_TT_Sk symbol

Interfaces:

Table 71: P31sDm_TT_Sk input and output signals

Input(s)	Output(s)
P31s_CI_D	P31sD_AI_TSF
P31s_CI_CK	P31sD_AI_TSD
P31s_CI_FS	P31sDm_TT_Sk_MI_cLTC
P31s_CI_SSF	P31sDm_TT_Sk_MI_cTIM
P31sDm_TT_Sk_MI_ExtI	P31sDm_TT_Sk_MI_cUNEQ
P31sDm_TT_Sk_MI_SSF_Reported	P31sDm_TT_Sk_MI_cDEG
P31sDm_TT_Sk_MI_RDI_Reported	P31sDm_TT_Sk_MI_cRDI
P31sDm_TT_Sk_MI_ODI_Reported	P31sDm_TT_Sk_MI_cSSF
P31sDm_TT_Sk_MI_TIMdis	P31sDm_TT_Sk_MI_cODI
P31sDm_TT_Sk_MI_DEGM	P31sDm_TT_Sk_MI_AcTI
P31sDm_TT_Sk_MI_DEGTHR	P31sDm_TT_Sk_MI_pN_EBC
P31sDm_TT_Sk_MI_1second	P31sDm_TT_Sk_MI_pF_EBC
P31sD_TT_Sk_MI_TPmode	P31sDm_TT_Sk_MI_pN_DS
	P31sDm_TT_Sk_MI_pF_DS
	P31sDm_TT_Sk_MI_pOF_EBC
	P31sDm_TT_Sk_MI_pOF_DS

Processes:

This function can be used to perform the following:

- 1) single ended maintenance of the TC by monitoring at an intermediate node, using remote information (RDI,REI);
- 2) aid in fault localization within TC trail by monitoring near-end defects;
- 3) monitoring of P31s performance at TC egressing point (except for connectivity defects before the TC) using remote outgoing information (ODI,OEI).

TC EDC violations: Even bit parity shall be computed for each bit n of every byte of the preceding P31s and compared with bit n of EM recovered from the current frame ($n=1$ to 8 inclusive). A difference between the computed and recovered EM values shall be taken as evidence of one or more errors in the computation block (nON_B). The magnitude (absolute value) of the difference between this calculated number of errors and the number of errors written into the IEC (see table 68) at the trail termination source shall be used to determine the error performance of the tandem connection for each transmitted P31s (see figure 99). If this magnitude of the difference is one or more, an errored TC block is detected (nN_B). Refer to P31sD_TT_Sk. If one or more errors were detected in the computation block, an errored P31s block (nON_B) shall be declared.

NR[1-4]: The function shall extract the Incoming Error Code (IEC). It shall accept the received code without further processing.

NR[7-8][9-72]: The Received Trail Trace Identifier RxTI shall be recovered from the tandem connection trail trace identifier overhead and shall be made available as AcTI for network management purposes. The application and acceptance process shall be performed as specified in EN 300 417-1-1 [9], clauses 7.1 and 8.2.1.3. The mismatch detection process shall be as specified below.

The trace identifier process in this function is required to support "mode 1" (EN 300 417-1-1 [9], clause 7.1) operation only. "Old" tandem connection equipment does not exist.

NR[1-4]: The function shall extract the Incoming AIS code.

NR[5], NR[8][73]: The information carried in the REI, RDI bits in byte NR shall be extracted to enable single ended maintenance of a bi-directional tandem connection Trail. The REI (nF_B) shall be used to monitor the error performance of the other direction of transmission, and the RDI shall be used to provide information as to the status of the remote receiver. A "1" indicates a Remote Defect Indication state, while a "0" indicates the normal, working state. The application process shall be performed as specified in EN 300 417-1-1 [9], clauses 7.4.2 (REI), 7.4.11 and 8.2 (RDI).

NR[6], NR[7][74]: The information carried in the OEI, ODI bits in byte NR shall be extracted to enable single ended (intermediate) maintenance of a the P31s egressing the tandem connection Trail. The OEI (nOF_B) shall be used to monitor the error performance of the other direction of transmission, and the ODI shall be used to provide information as to the status of the remote receiver. A "1" indicates a Outgoing Defect Indication state, while a "0" indicates the normal, working state. The application process shall be performed equivalent to the remote maintenance case, as specified in EN 300 417-1-1 [9], clauses 7.4.2 (REI/OEI), 7.4.11 and 8.2 (RDI/ODI).

NR[7-8] - Multiframe alignment: The function shall perform a multiframe alignment on bits 7 and 8 of byte NR to recover the TTI, RDI, and ODI signals transported within the multiframe bits. The multiframe alignment shall be found by searching for the pattern "1111 1111 1111 1110" within the bits 7 and 8 of byte NR. The signal shall be continuously checked with the presumed multiframe start position for the alignment.

Frame alignment is deemed to have been lost (entering Out Of Multiframe (OOM) state) when two consecutive FAS are detected in error (i.e. ≥ 1 error in each FAS).

Frame alignment is deemed to have been recovered (entering In Multiframe (IM) state) when one non-errored FAS is found.

Defects:

TC Unequipped (dUNEQ):

The function shall detect for an unequipped Tandem Connection (UNEQ) condition by monitoring byte NR for code "00000000". The unequipped defect (dUNEQ) shall be detected if five consecutive P31s frames contain the "0000 0000" pattern in byte NR. The dUNEQ defect shall be cleared if in five consecutive NR frames any pattern other than the "0000 0000" is detected in byte NR.

TC Loss of Tandem Connection (dLTC):

The function shall detect for the presence/absence of the tandem connection overhead in the byte NR by evaluating the multiframe alignment signal in bits 7 and 8 of byte NR. The loss of tandem connection defect (dLTC) shall be detected if the multiframe alignment process is in the OOM state. The dLTC shall be cleared if the multiframe alignment process is in the IM state.

TC Connectivity (Trace Identifier) (dTIM):

The function shall detect for a TC mis-connection condition by monitoring the TC trace identifier. The Trace Identifier Mismatch defect (dTIM) shall be detected and cleared within a maximum period of 1 s in the absence of bit errors.

The defect detection process and its operation during the presence of bit errors is for further study.

The defect shall be suppressed during the receipt of SSF.

It shall be possible to disable the trace identifier mismatch defect detection (TIMdis).

TC Signal Degrade (dDEG):

The function shall detect for a TC signal degrade defect condition by monitoring for TC BIP-8 violations. The algorithm shall be according clause 8.2.1.4 in EN 300 417-1-1 [9].

TC Remote Defect (dRDI):

The function shall detect for a TC remote defect indication defect condition by monitoring the TC RDI signal. The algorithm shall be according clause 8.2.1.5 in EN 300 417-1-1 [9].

TC Remote Outgoing P31s Defect (dODI):

The function shall detect for a TC remote outgoing P31s defect indication defect condition by monitoring the TC ODI signal. The algorithm shall be according clause 8.2.1.5 in EN 300 417-1-1 [9].

Consequent actions:

aTSF ← CI_SSF or dUNEQ or dTIM or dLTC
aTSD ← dDEG

Defect correlations:

The function shall perform the following defect correlations (refer to clause 8.2.3 in EN 300 417-1-1 [9]):

cUNEQ ← MON and dUNEQ
cLTC ← MON and (not dUNEQ) and dLTC
cTIM ← MON and (not dUNEQ) and (not dLTC) and dTIM
cDEG ← MON and (not dTIM) and (not dLTC) and dDEG
cSSF ← MON and CI_SSF and SSF_reported
cRDI ← MON and (not dUNEQ) and (not dTIM) and (not dLTC) and dRDI and RDI_reported
cODI ← MON and (not dUNEQ) and (not dTIM) and (not dLTC) and dODI and ODI_Reported

It shall be an option to report SSF as a fault cause. This is controlled by means of the parameter SSF_Reported. The default shall be SSF_Reported = false.

It shall be an option to report RDI as a fault cause. This is controlled by means of the parameter RDI_Reported. The default shall be RDI_Reported = false.

It shall be an option to report ODI as a fault cause. This is controlled by means of the parameter ODI_Reported. The default shall be ODI_Reported = false.

Performance monitoring:

The following TC error performance parameters shall be counted for each 1-second period (refer to clauses 8.2.4 to 8.2.7 in EN 300 417-1-1 [9]):

pN_DS	←	aTSF or dEQ
pF_DS	←	dRDI
pN_EBC	←	ΣnN_B
pF_EBC	←	ΣnF_B
pOF_DS	←	dODI
pOF_EBC	←	ΣnOF_B

9 P4s path layer functions

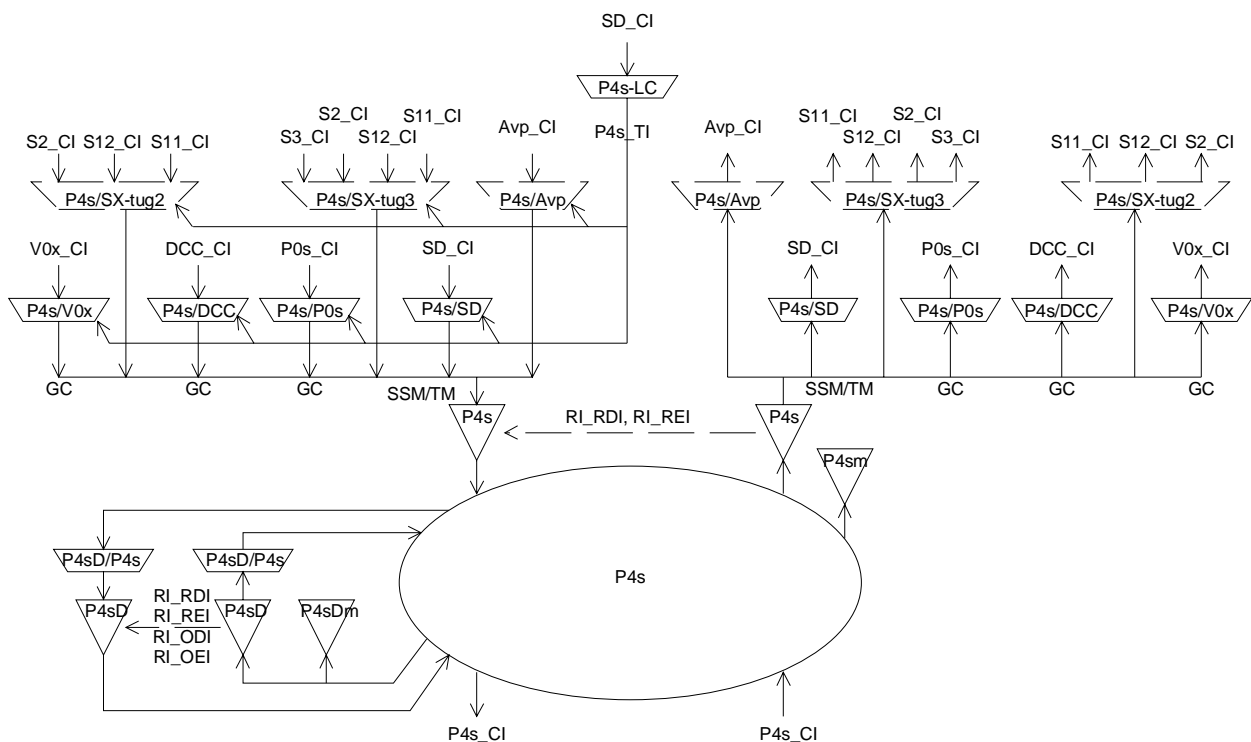

Figure 103: P4s path layer atomic functions

P4s layer CP

The Characteristic Information (CI) at this point is octet structured with an 125 μ s frame (see figure 104). Its format is characterized as P4s_AI plus the P4s trail termination overhead in the TR, EM, and MA locations as defined in ETS 300 337 [10]. For the case the signal has passed the tandem connection sublayer, P4s_CI has defined P4s tandem connection trail termination overhead in location NR.

NOTE 1: NR will be undefined when the signal P4s_CI has not been processed in a tandem connection adaptation and trail termination function.

NOTE 2: An unequipped P4s signal is for further study.

P4s layer AP

The Adaptation Information (AI) at this point is octet structured with an 125 μs frame (see figure 104). It represents adapted client layer information comprising 2 160 bytes of client layer information, the signal label bits in byte MA, the multiframe indicator in byte MA, the synchronization status message/timing marker bit in byte MA, and a 64 kbit/s general communication channel in byte GC. For the case the signal has passed the trail protection sublayer, P4s_AI has defined APS in bytes P1P2.

NOTE 3: Bytes P1P2 will be undefined when the signal P4s_AI has not been processed in a trail protection connection function P4sP_C.

NOTE 4: The structure of bytes P1P2 is not yet defined.

NOTE 5: GC will be undefined when no GC byte adaptation source function is connected to the AP.

The composition of the payload transported by an P4s will be determined by the client layer application. Typical compositions of the payload include:

- a TUG3 structured signal;
- a TUG2 structured signal;
- an ATM 138 240 kbit/s cell stream signal.

Figure 103 shows that more than one adaptation function exists in this P4s layer that can be connected to one P4s access point. For the case of the adaptation source functions, only one of these adaptation source functions is allowed to be activated. For this activated source, access to the access point by other adaptation source functions shall be denied. In contradiction with the source direction, adaptation sink functions may be activated all together. This may cause faults (e.g. cLOF) to be detected and reported. To prevent this an adaptation sink function can be deactivated.

NOTE 6: If one adaptation function only is connected to the AP, it will be activated. If one or more other functions are connected to the same AP, one out of the set of functions will be active.

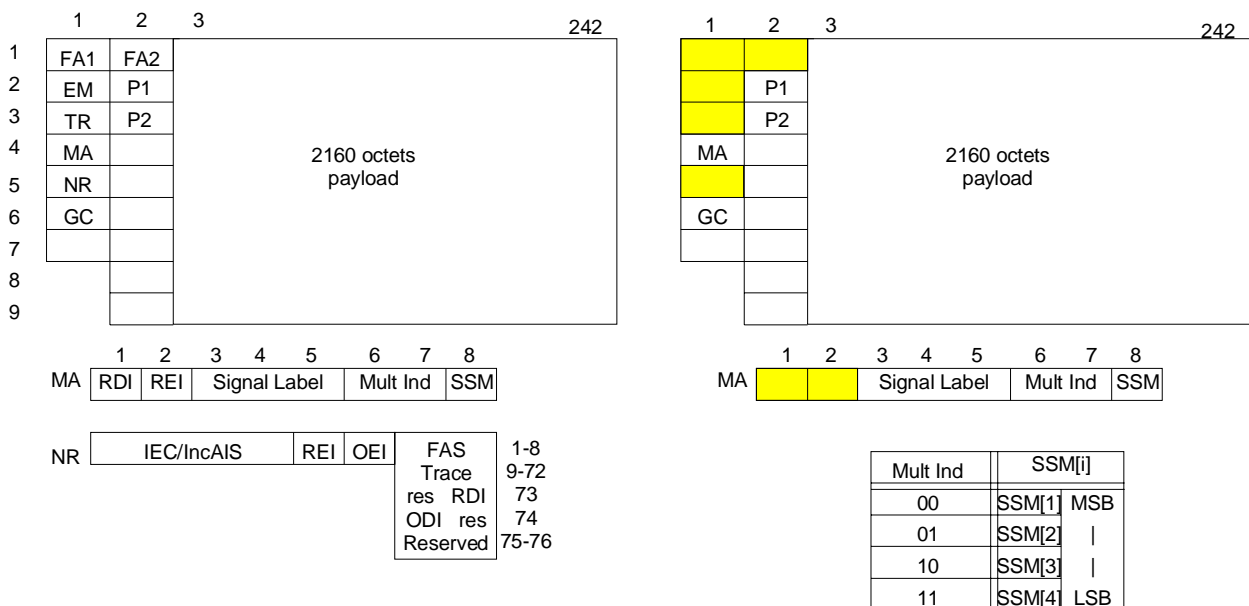

Figure 104: P4s_CI_D (left) and P4s_AI_D (right)

9.1 P4s connection functions

For further study.

9.2 P4s trail termination functions

9.2.1 P4s trail termination source P4s_TT_So

Symbol:

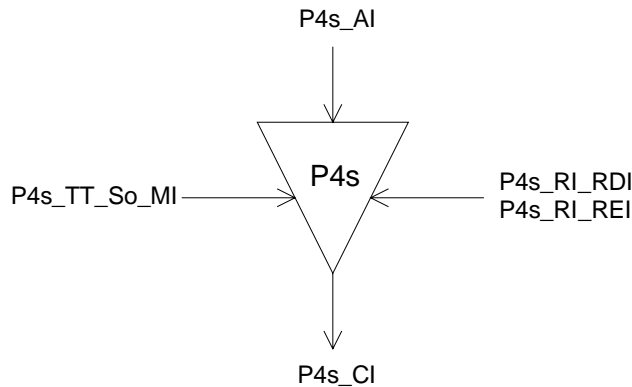

Figure 105: P4s_TT_So symbol

Interfaces:

Table 72: P4s_TT_So input and output signals

Input(s)	Output(s)
P4s_AI_D	P4s_CI_D
P4s_AI_CK	P4s_CI_CK
P4s_AI_FS	P4s_CI_FS
P4s_RI_RDI	
P4s_RI_REI	
P4s_TT_So_MI_TxTI	

Processes:

This function adds error monitoring, status overhead bytes, trace identifier and the frame alignment signal to the P4s_AI presented at its input, to form the P31s layer Characteristic Information. The processing of the trail termination overhead bytes is defined as follows:

TR: In this byte the function shall insert the Transmitted Trail Trace Identifier TxTI. Its format is described in EN 300 417-1-1 [9], clause 7.1.

MA[1]: Bit 1, a RDI indication, shall be set to "1" on activation of the RI_RDI within 1 ms, determined by the associated P4s_TT_Sk function, and set to "0" within 1 ms on clearing of RI_RDI.

MA[2]: Bit 2, a REI (Remote Error Indication) indication, shall be set to "1" within 1 ms on declaration of RI_REI - determined by the associated P4s_TT_Sk function if one or more errors were detected by the BIP-8 process - and shall be otherwise set to zero within 1 ms.

EM: In this byte the function shall insert the BIP-8 EDC with even bit parity. Each bit n of current EM is computed to provide even parity over the n^{th} bit of every byte in the previous frame of the Characteristic Information P4s_CI, i.e. EM is calculated over the entire previous P4s signal. Further reference is provided in EN 300 417-1-1 [9], clause 7.3 and ETS 300 337 [10].

FA1FA2 - Frame Alignment Signal (FAS): The function shall insert the 139 264 kbit/s 125 μ s frame alignment signal FA1FA2 into the frame overhead as defined in ETS 300 337 [10] and depicted in figure 104.

Defects:	none.
Consequent actions:	none.
Defect correlations:	none.
Performance monitoring:	none.

9.2.2 P4s trail termination sink P4s_TT_Sk

Symbol:

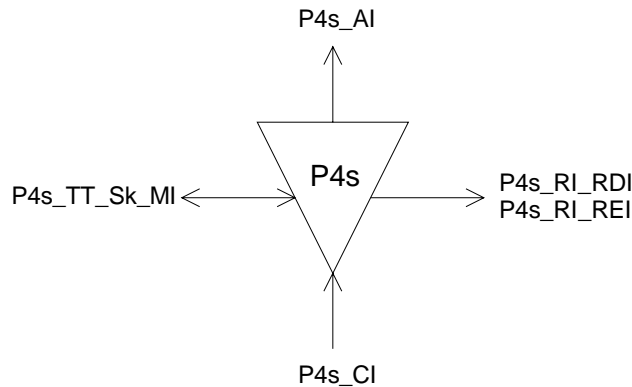

Figure 106: P4s_TT_Sk symbol

Interfaces:

Table 73: P4s_TT_Sk input and output signals

Input(s)	Output(s)
P4s_CI_D	P4s_AI_D
P4s_CI_CK	P4s_AI_CK
P4s_CI_FS	P4s_AI_FS
P4s_CI_SSF	P4s_AI_TSF
P4s_TT_Sk_MI_ExTI	P4s_AI_TSD
P4s_TT_Sk_MI_TPmode	P4s_RI_RDI
P4s_TT_Sk_MI_DEGTHR	P4s_RI_REI
P4s_TT_Sk_MI_DEGM	P4s_TT_Sk_MI_cUNEQ
P4s_TT_Sk_MI_1second	P4s_TT_Sk_MI_cTIM
P4s_TT_Sk_MI_SSF_Reported	P4s_TT_Sk_MI_cDEG
P4s_TT_Sk_MI_RDI_Reported	P4s_TT_Sk_MI_cRDI
P4s_TT_Sk_MI_TIMdis	P4s_TT_Sk_MI_cSSF
	P4s_TT_Sk_MI_pN_DS
	P4s_TT_Sk_MI_pF_DS
	P4s_TT_Sk_MI_pN_EBC
	P4s_TT_Sk_MI_pF_EBC
	P4s_TT_Sk_MI_AcTI

Processes:

This function monitors for 140 Mbit/s frame errors and recovers the trail termination status as defined in ETS 300 337 [10]. It extracts the payload independent overhead bytes EM, TR, MA bits 1, 2 from the P4s layer Characteristic information:

EM: Even bit parity (BIP-8) shall be computed for each bit n of every byte of the preceding frame and compared with bit n of EM recovered from the current frame ($n=1$ to 8 inclusive). A difference between the computed and recovered EM values shall be taken as evidence of one or more errors (nN_B) in the computation block.

TR: The 16 byte Trail Trace Identifier (TTI) is recovered from the TR byte and is made available for network management purposes. The application and the acceptance and mismatch detection process shall be performed as described in the EN 300 417-1-1 [9], clauses 7.1 and 8.2.1.3.

The trace identifier process in this function is required to support "mode 1" (EN 300 417-1-1 [9], clause 7.1) only. "Transmission and Multiplexing (TM); Generic requirements of transport functionality of equipment; Part 1-1: Generic processes and performance" P4s connection equipment does not exist.

MA[1-2]: The relevant information carried in the MA byte (RDI in bit 1, REI in bit 2) shall be extracted to enable single ended maintenance of a bi-directional Trail. The REI (nF_B) shall be used to monitor the error performance of the reverse direction of transmission; the RDI provides information as to the status of the remote receiver. A "1" indicates a RDI state, while a "0" indicates the normal working state. The application process shall be performed as specified in EN 300 417-1-1 [9], clauses 7.4. and 8.2.1.

MA[3-5]: The information in the signal label bits shall be extracted to allow unequipped P4s defect detection.

Defects:

The detection and removal conditions and processes for dUNEQ, dDEG, dRDI and dTIM are described in EN 300 417-1-1 [9], clause 8.2.1.

Consequent actions:

aAIS	←	dUNEQ or dTIM
aRDI	←	CI_SSF or dUNEQ or dTIM
aTSF	←	CI_SSF or dUNEQ or dTIM
aTSD	←	dDEG

On declaration of an aAIS the function shall output an all ONEs signal within 250 µs; on clearing of aAIS the function shall output normal data within 250 µs.

Defect correlations:

cUNEQ	←	MON and dUNEQ
cTIM	←	MON and dTIM (and not dUNEQ)
cDEG	←	MON and dDEG and (not dUNEQ) and (not dTIM)
cRDI	←	MON and dRDI and (not dTIM) and (not dUNEQ) and RDI_Reported
cSSF	←	MON and CI_SSF and SSF_Reported

It shall be an option to report SSF as a fault cause. This is controlled by means of the parameter SSF_Reported. The default shall be SSF_Reported = false.

It shall be an option to report RDI as a fault cause. This is controlled by means of the parameter RDI_Reported. The default shall be RDI_Reported = false.

Performance monitoring:

The performance monitoring process shall be performed as specified in EN 300 417-1-1 [9], clauses 8.2.4 to 8.2.7.

pN_DS	←	aTSF or dEQ
pF_DS	←	dRDI
pN_EBC	←	ΣnN_B
pF_EBC	←	ΣnF_B

9.3 P4s adaptation functions

9.3.1 P4s layer to VC-3, VC-2, VC-12, and VC-11 layer compound adaptation source function P4s/SX-TUG3_A_So

Symbol:

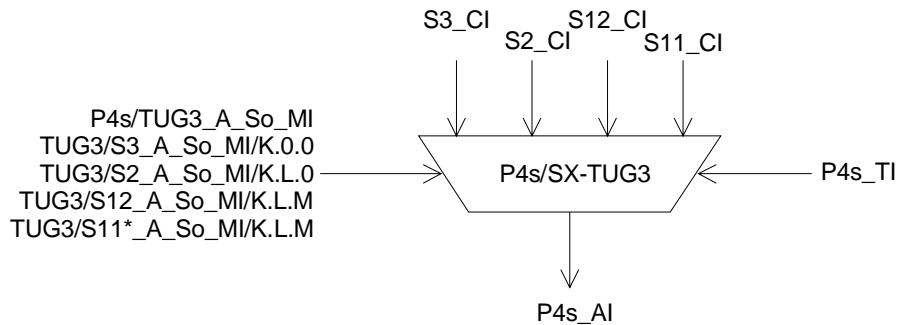

Figure 107: P4s/SX-TUG3_A_So symbol

Interfaces:

Table 74: P4s/SX-TUG3_A_So input and output signals

Input(s)	Output(s)
P4s/TUG3_A_So_MI P4s_TI	P4s_AI
maximum 2 inputs: S3_CI TUG3/S3_A_So_MI/K.0.0	
maximum 19 inputs: S2_CI TUG3/S2_A_So_MI/K.L.0	
maximum 57 inputs: S12_CI TUG3/S12_A_So_MI/K.L.M	
maximum 57 inputs: S11_CI TUG3/S11*_A_So_MI/K.L.M	

Processes:

The P4s/SX-TUG3_A_So compound function provides adaptation from the VC-3/2/12/11 layers to the P4s layer. This process is performed by a combination of several atomic functions as shown in figure 108. The P4s/TUG3_A_So function performs the P4s layer specific signal label and multiframe processing, while the TUG3/S3_A_So, TUG3/S2_A_So, TUG3/S12_A_So and TUG3/S11*_A_So functions perform the lower order VC specific frequency justification and bitrate adaptation. Each of these TUG3/Sm_A_So functions is characterized by the K.L.M parameters, which define the number of the TU within the P4s the function has access to (TU numbering scheme according to figure B-1). According to the TUG3 multiplex structures supported by the NE, a variety of possible combinations of these TUG3/Sm_A_So functions exists. Table 75 lists all possible TUG3/Sm_A_So functions within a P4s/SX-TUG3_A_So compound functions.

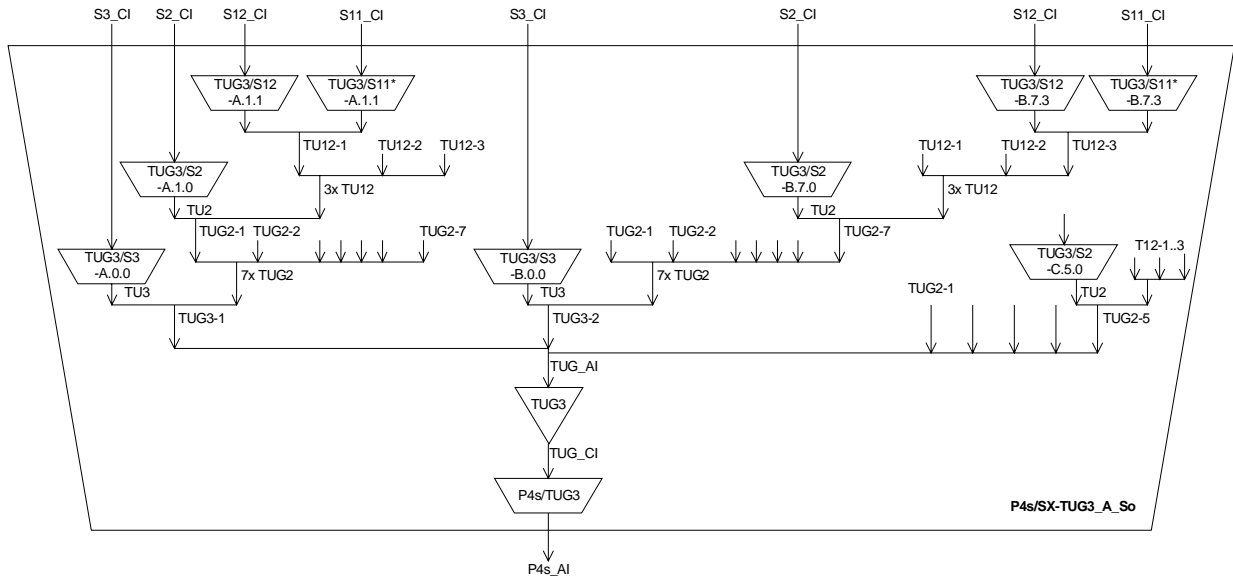

Figure 108: P4s/SX-TUG3_A_So compound function with set of TUG/Sm_A_So atomic functions

Table 75: Possible TUG3/Sm_A_So functions of a P4s/SX-TUG3_A_So compound function

Atomic function	TU-3/TUG-3 number K	TU-2/TUG-2 number L	TU-12 number M
TUG3/S3_A_Sk/K.0.0	A,B	0	0
TUG3/S2_A_Sk/K.L.0	A,B,C	1 to 7 (A,B) 1 to 5 (C)	0
TUG3/S12_A_Sk/K.L.M	A,B,C	1 to 7 (A,B) 1 to 5 (C)	1 to 3
TUG3/S11*_A_Sk/K.L.M	A,B,C	1 to 7 (A,B) 1 to 5 (C)	1 to 3

For specific implementations only a subset of these TUG3/Sm_A_So functions may be used (e.g. a terminal multiplexer with fixed 2 Mbit/s access has 57 TUG/S12_A_So functions). If a flexible TUG3 multiplex structure is supported, several TUG3/Sm_A_So functions may have access to the same TU timeslot. For such case, only one of these adaptation source functions is allowed to be activated. This is controlled by the equipment management function by activating/deactivating the functions according to the configured TUG3 multiplex structure.

NOTE 1: The P4s/TUG3_A_So, TUG3_T_So and TUG3/Sm_A_So (m = 3, 2, 12, 11*) defined in the following clauses can only be used in a P4s/SX-TUG3_A_So compound function. These functions can not be used as stand alone functions.

NOTE 2: The TUG3 is a virtual sub-layer only applicable in a P4s/SX-TUG3_A compound function.

The number of TUG3/Sm_A (m=3,2,12,11*) functions that is active shall completely fill the P4s payload.

9.3.1.1 P4s layer to TUG3 adaptation source function P4s/TUG3_A_So

Symbol:

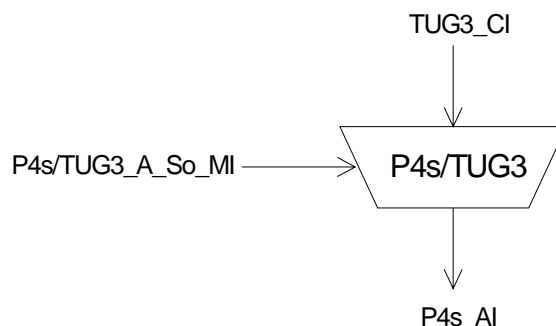

Figure 109: P4s/TUG3_A_So symbol

Interfaces:

Table 76: P4s/TUG3_A_So input and output signals

Input(s)	Output(s)
TUG3_CI_D	P4s_AI_D
TUG3_CI_CK	P4s_AI_CK
TUG3_CI_FS	P4s_AI_FS
TUG3_CI_MFS	
P4s/TUG3_A_So_MI_Active	
P4s/TUG3_A_So_MI_TU3_1	
P4s/TUG3_A_So_MI_TU3_2	

NOTE 1: The P4s/TUG3_A_So functions can only be used in a P4s/SX-TUG3_A_So compound function. It can not be used as a stand alone function.

NOTE 2: P4s/TUG3_A_So_MI_TU3_1 is true if TUG3/S3_A_So/A.0.0_MI_Active is true.
 P4s/TUG3_A_So_MI_TU3_2 is true if TUG3/S3_A_So/B.0.0_MI_Active is true.

Processes:

The function adds two payload specific signals (bits MA[3-5] and MA[6-7]) to the P4s POH and fixed stuff (R0) bytes to the P4s payload (see figure 111). The fixed stuff bytes R1 and R2 are added depending on the TUG3 multiplex structure.

NOTE 3: The fixed stuff bytes (R0, R1, R2) are undefined.

MA[3-5]: In this byte the function shall insert code "100" (SDH elements mapping II: 2 × TUG-3 and 5 × TUG-2 structure) as defined in ETS 300 337 [10].

MA[6-7]: The value of the multiframe indicator MA[6-7] shall be set as specified by ETS 300 337 [10], 500 μs TU multiframe sequence, and aligned with TUG3_CI_MFS.

					multiframe indicator		
1	2	3	4	5	6	7	8

Figure 110: TU multiframe indicator bits in byte MA

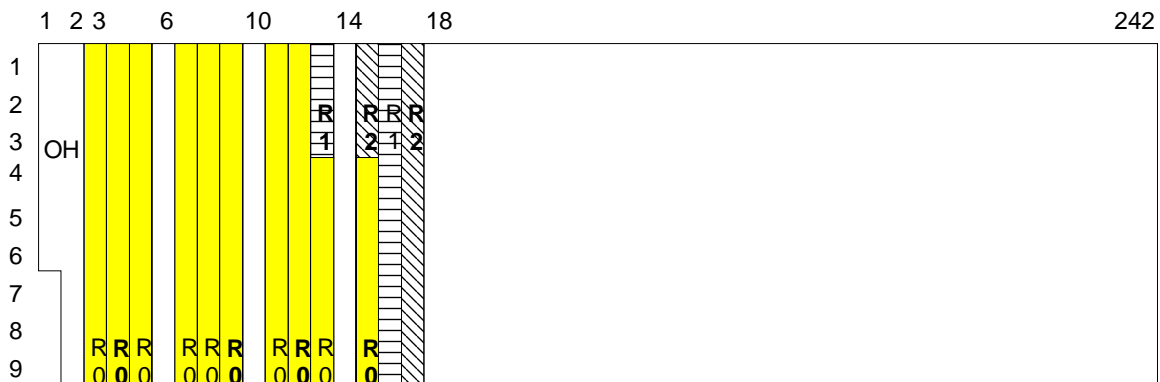

Figure 111: P4s payload (TUGs and fixed stuff "R" bytes)

Fixed Stuff bytes: The R0 bytes are always added. The R1 bytes are added if the TUG-3-A contains TUG-2s (MI_TU3_1 is false). The R2 bytes are added if the TUG-3-B contains TUG-2s (MI_TU3_2 is false).

Activation: The function shall access the access point when it is activated (MI_Active is true). Otherwise, it shall not access the access point.

Defects: none.

Consequent actions: none.

Defect correlations: none.

Performance monitoring: none.

9.3.1.2 TUG3 trail termination source function TUG3_T_So

Symbol:

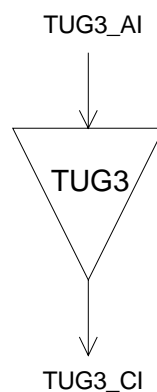

Figure 112: TUG3_T_So symbol

Interfaces:

Table 77: TUG3_T_So input and output signals

Input(s)	Output(s)
TUG3_AI_D	TUG3_CI_D
TUG3_AI_CK	TUG3_CI_CK
TUG3_AI_FS	TUG3_CI_FS
TUG3_AI_MFS	TUG3_CI_MFS
NOTE: The TUG3_T_So functions can only be used in a P4s/SX-TUG3_A_So compound function. It can not be used as a stand alone function.	

Processes: none.

Defects: none.

Consequent actions: none.

Defect correlations: none.

Performance monitoring: none.

9.3.1.3 TUG3 to VC-3 layer adaptation source function TUG3/S3_A_So/K.0.0

Symbol:

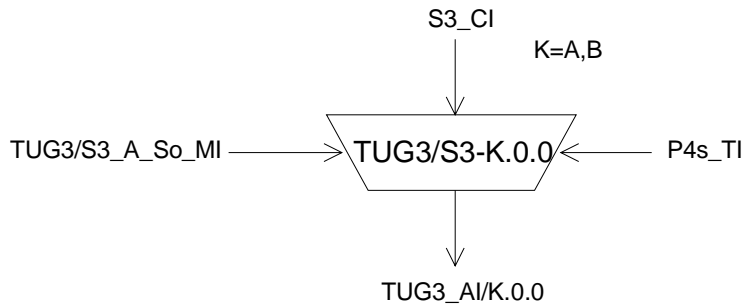
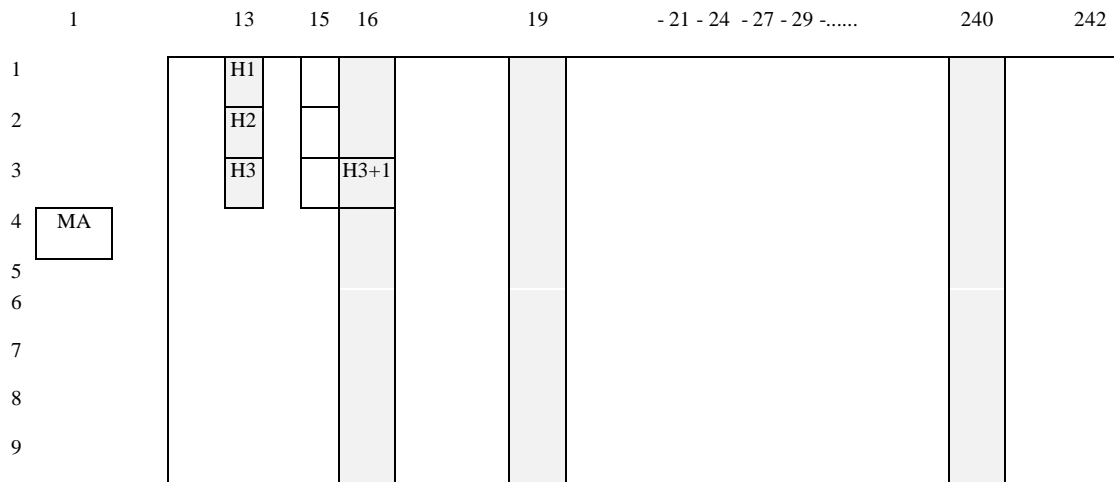

Figure 113: TUG3/S3_A_So symbol

Interfaces:

Table 78: TUG3/S3_A_So input and output signals

Input(s)	Output(s)
S3_CI_D S3_CI_CK S3_CI_FS S3_CI_SSF P4s_TI_CK P4s_TI_FS TUG3/S3_A_So_MI_Active	TUG3_AI_D TUG3_AI_CK TUG3_AI_FS
NOTE: The TUG3/S3_A_So functions can only be used in a P4s/SX-TUG3_A_So compound function. It can not be used as a stand alone function.	



indicates the 768 bytes belonging to the TU-3 (A0,0)

Figure 114: TUG3_AI_D/A.0.0 signal

Processes:

This function provides frequency justification and bitrate adaptation for a VC-3 signal, represented by a nominally $(765 \times 64) = 48\,960$ kbit/s information stream with a frequency accuracy within $\pm 4,6$ ppm and the related frame phase, to be multiplexed into a P4s signal via a TU-3.

NOTE 1: Degraded performance may be observed when interworking with SONET equipment having a ± 20 ppm network element clock source.

The frame phase of the VC-3 is coded in the related TU-3 pointer. Frequency justification, if required, is performed by pointer adjustments. The accuracy of this coding process is specified below. Refer to annex A of EN 300 417-4-1 [11].

Frequency justification and bitrate adaptation: The function shall provide an elastic store (buffer) process. The data and frame start signals shall be written into the buffer under control of the associated input clock. The data and frame start signals shall be read out of the buffer under control of the P4s clock, frame position, and justification decision.

The justification decisions determine the phase error introduced by the TUG3/S3_A_So function. The amount of this phase error can be measured at the physical interfaces by monitoring the TU-3 pointer actions. An example is given in clause A.2 of EN 300 417-4-1 [11].

Each justification decision results in a corresponding negative/positive justification action. Upon a positive justification action, the reading of 8 data bits shall be cancelled once and no data are written at the justification opportunity position H3+1. Upon a negative justification action, an extra 8 data bits shall be read out once into the justification opportunity position H3.

NOTE 2: A requirement for maximum introduced phase error cannot be defined until a reference path is defined from which the requirements for network elements can be deduced. Such a requirement would also limit excessive phase error caused by pointer processors under fixed frequency offset conditions.

Buffer size: For further study.

The TU-3 pointer is carried in 2 bytes of payload specific OH in each container frame. The TU-3 pointer is aligned in the P4s payload in fixed position relative to the P4s frame. The TU-3 pointer points to the begin of the VC-3 frame within the P4s. The format of the TU-3 pointer and its location in the frame are defined in ETS 300 337 [10].

H1, H2 - Pointer generation: The function shall generate the TU-3 pointer as is described in EN 300 417-1-1 [9], annex A: Pointer Generation. It shall insert the pointer in the appropriate H1, H2 positions with the SS field set to 10 to indicate TU-3.

TU-3 timeslot: The adaptation source function has access to a specific TU-3 of the TUG3 access point. The TU-3 is defined by the parameter K (K=A,B).

Figure 108 shows that more than one adaptation source function exists in the TUG3 virtual sub-layer that can be connected to one TUG3 access point. For such case, a subset of these adaptation source functions is allowed to be activated together, but only one adaptation source function may have access to a specific TU *timeslot*. Access to the same TU *timeslot* by other adaptation source functions shall be denied.

Activation: The function shall access the access point when it is activated (MI_Active is true). Otherwise, it shall not access the access point.

Defects: none.

Consequent actions:

aAIS ← CI_SSF

On declaration of aAIS the function shall output an all-ONEs signal within 250 μ s; on clearing of aAIS the function shall output normal data within 250 μ s.

NOTE 3: If CI_SSF is not connected (when connected to a S3_TT_So), CI_SSF is assumed to be false.

Performance monitoring: none.

9.3.1.4 TUG3 to VC-2 layer adaptation source function TUG3/S2_A_So/K.L.0

Symbol:

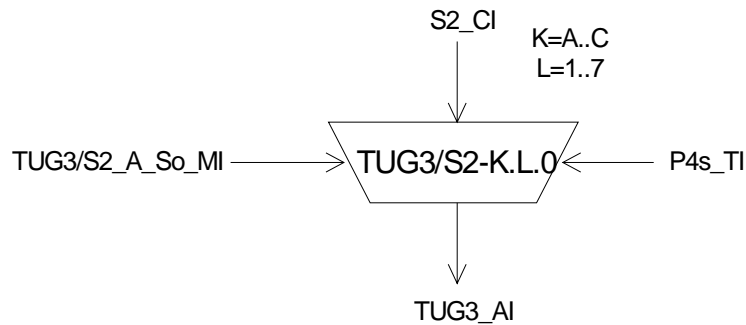

Figure 115: TUG3/S2_A_So symbol

Interfaces:

Table 79: TUG3/S2_A_So input and output signals

Input(s)	Output(s)
S2_CI_D	TUG3_AI_D
S2_CI_CK	TUG3_AI_CK
S2_CI_FS	TUG3_AI_FS
S2_CI_SSF	TUG3_AI_MFS
P4s_TI_CK	
P4s_TI_FS	
P4s_TI_MFS	
TUG3/S2_A_So_MI_Active	
NOTE 1: The TUG3/S2_A_So functions can only be used in a P4s/SX-TUG3_A_So compound function. It can not be used as a stand alone function.	

Processes:

This function provides frequency justification and bitrate adaptation for a VC-2 signal, represented by a nominally $(428 \times 64/4) = 6\,848$ kbit/s information stream with a frequency accuracy within $\pm 4,6$ ppm and the related frame phase, to be multiplexed into a P4s signal via a TU-2.

NOTE 1: Degraded performance may be observed when interworking with SONET equipment having a ± 20 ppm network element clock source.

The (500 μ s) frame phase of the VC-2 is coded in the related TU-2 pointer. Frequency justification, if required, is performed by pointer adjustments. The accuracy of this coding process is specified below. Refer to annex A of EN 300 417-4-1 [11].

Frequency justification and bitrate adaptation: The function shall provide an elastic store (buffer) process. The data and frame start signals shall be written into the buffer under control of the associated input clock. The data and frame start signals shall be read out of the buffer under control of the P4s clock, frame position, and justification decision.

The justification decisions determine the phase error introduced by the TUG3/S2_A_So function. The amount of this phase error can be measured at the physical interfaces by monitoring the TU-2 pointer actions. An example is given in clause A.2 of EN 300 417-4-1 [11].

Each justification decision results in a corresponding negative/positive justification action. Upon a positive justification action, the reading of 8 data bits shall be cancelled once and no data are written at the justification opportunity position V3+1 (see figure 116). Upon a negative justification action, an extra 8 data bits shall be read out once into the justification opportunity position V3.

NOTE 2: A requirement for maximum introduced phase error cannot be defined until a reference path is defined from which the requirements for network elements can be deduced. Such a requirement would also limit excessive phase error caused by pointer processors under fixed frequency offset conditions.

Buffer size: For further study.

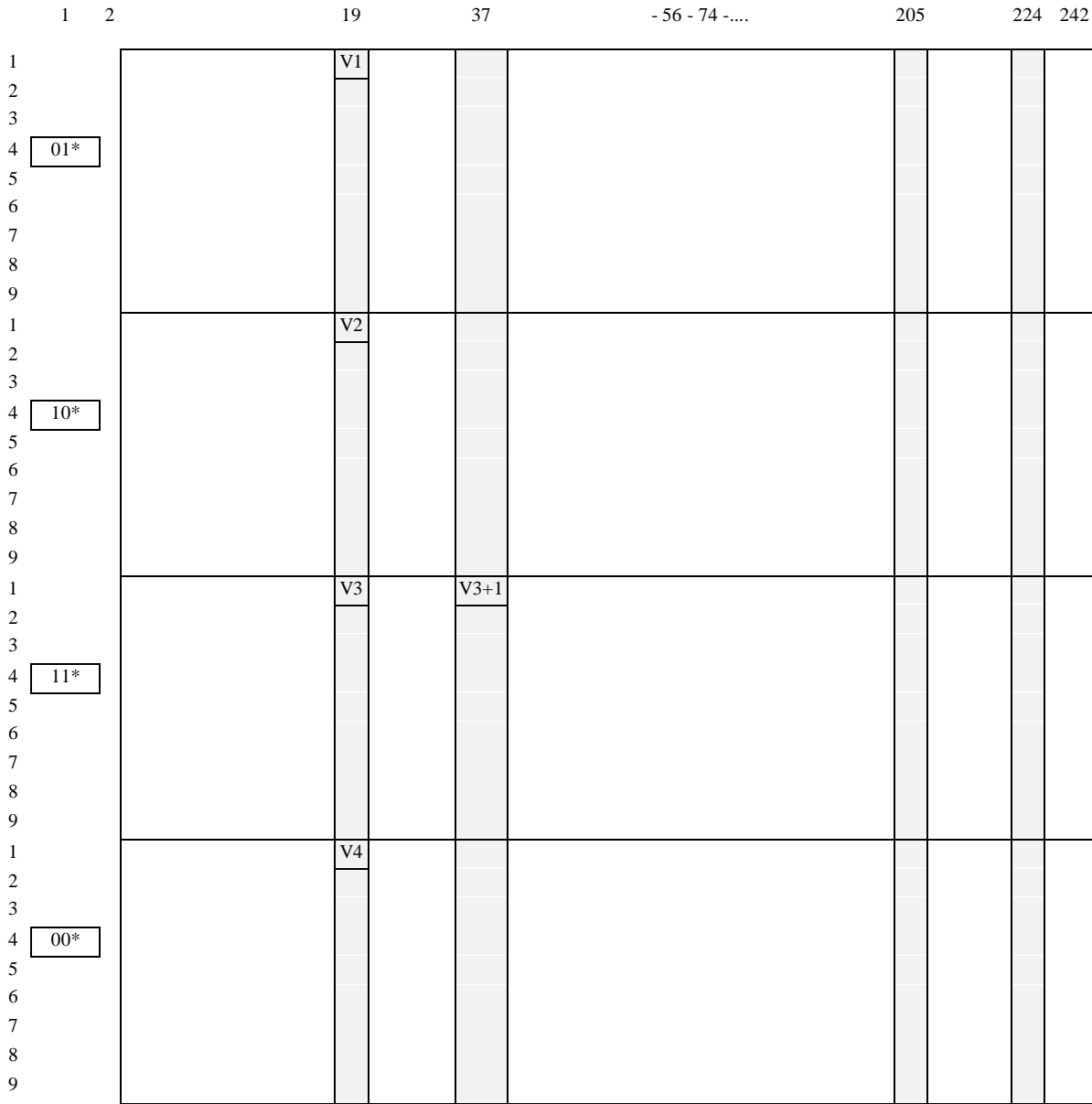

□ indicates the 432 bytes belonging to the TU-2 (A,1,0)
 01*, 10*, 11*, and 00* indicate code value in bits MA[6-7]

Figure 116: TUG_AI_D/A.1.0 signal

The TU-2 pointer is carried in bytes V1 and V2 of payload specific OH once per 500 μs multiframe (see figure 116). The TU-2 pointer is aligned in the P4s payload in fixed positions relative to the P4s frame and multiframe. The format of the TU-2 pointer and its location in the frame/multiframe are defined in ETS 300 337 [10].

V1, V2 - Pointer generation: The function shall generate the TU-2 pointer as is described in EN 300 417-1-1 [9], annex A: Pointer Generation. It shall insert the pointer in the appropriate V1, V2 positions with the SS field set to 00 to indicate TU-2.

NOTE 3: The byte V4 is undefined.

TU-2 timeslot: The adaptation source function has access to a specific TU-2 of the TUG3 access point. The TU-2 is defined by the parameters K and L (K=A,B, L=1 to 7 and K=C, L=1 to 5).

Figure 108 shows that more than one adaptation source function exists in the TUG3 virtual sub-layer that can be connected to one TUG3 access point. For such case, a subset of these adaptation source functions is allowed to be activated together, but only one adaptation source function may have access to a specific TU timeslot. Access to the same TU timeslot by other adaptation source functions shall be denied.

Activation: The function shall access the access point when it is activated (MI_Active is true). Otherwise, it shall not access the access point.

Defects: none.

Consequent actions:

aAIS ← CI_SSF

On declaration of aAIS the function shall output an all ONEs signal within 1 ms; on clearing of aAIS the function shall output normal data within 1 ms.

NOTE 4: If CI_SSF is not connected (when connected to a S2_TT_So), CI_SSF is assumed to be false.

Defect correlations: none.

Performance monitoring: none.

9.3.1.5 TUG3 to VC-12 layer adaptation source function TUG3/S12_A_So/K.L.M

Symbol:

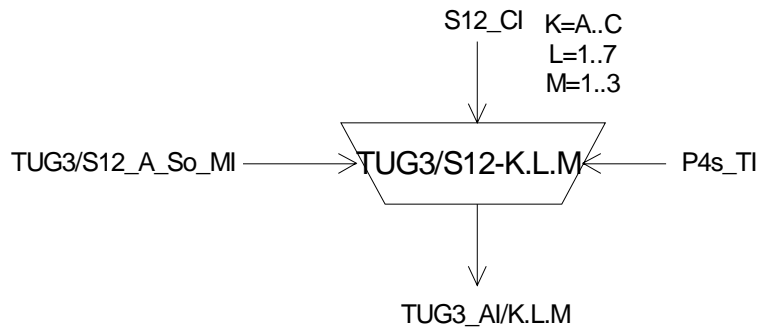

Figure 117: TUG3/S12_A_So symbol

Interfaces:

Table 80: TUG3/S12_A_So input and output signals

Input(s)	Output(s)
S12_CI_D S12_CI_CK S12_CI_FS S12_CI_SSF P4s_TI_CK P4s_TI_FS P4s_TI_MFS TUG3/S12_A_So_MI_Active	TUG3_AI_D TUG3_AI_CK TUG3_AI_FS
NOTE 1: The TUG3/S12_A_So functions can only be used in a P4s/SX-TUG3_A_So compound function. It can not be used as a stand alone function.	

Processes:

This function provides frequency justification and bitrate adaptation for a VC-12 signal, represented by a nominally $(140 \times 64 / 4) = 2\,240$ kbit/s information stream with a frequency accuracy within $\pm 4,6$ ppm and the related frame phase, to be multiplexed into a P4s signal via a TU-12.

NOTE 1: Degraded performance may be observed when interworking with SONET equipment having a ± 20 ppm network element clock source.

The (500 μ s) frame phase of the VC-12 is coded in the related TU-12 pointer. Frequency justification, if required, is performed by pointer adjustments. The accuracy of this coding process is specified below. Refer to annex A of EN 300 417-4-1 [11].

Frequency justification and bitrate adaptation: The function shall provide an elastic store (buffer) process. The data and frame start signals shall be written into the buffer under control of the associated input clock. The data and frame start signals shall be read out of the buffer under control of the P4s clock, frame position, and justification decision.

The justification decisions determine the phase error introduced by the TUG/S12_A_So function. The amount of this phase error can be measured at the physical interfaces by monitoring the TU-12 pointer actions. An example is given in clause A.2 of EN 300 417-4-1 [11].

Each justification decision results in a corresponding negative/positive justification action. Upon a positive justification action, the reading of 8 data bits shall be cancelled once and no data are written at the justification opportunity position V3+1 (see figure 116). Upon a negative justification action, an extra 8 data bits shall be read out once into the justification opportunity position V3.

NOTE 2: A requirement for maximum introduced phase error cannot be defined until a reference path is defined from which the requirements for network elements can be deduced. Such a requirement would also limit excessive phase error caused by pointer processors under fixed frequency offset conditions.

Buffer size: For further study.

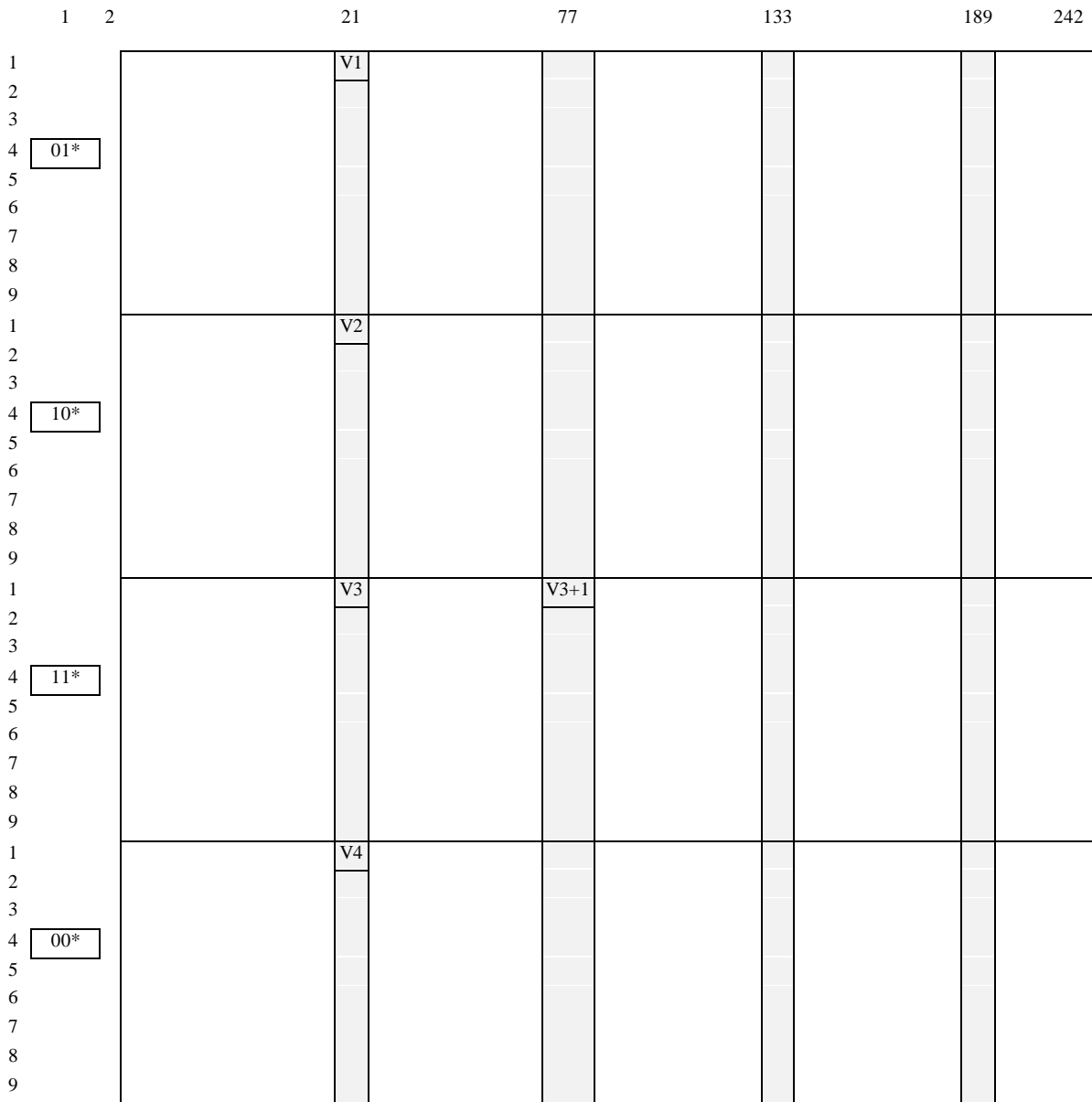

indicates the 144 bytes belonging to the TU-12 (A,2,1)
 01*, 10*, 11*, and 00* indicate code value in bits MA[6-7]

Figure 118: TUG3_AI_D/A.2.1 signal

The TU-12 pointer is carried in bytes V1 and V2 of payload specific OH per 500 μs multiframe (see figure 118). The TU-12 pointer is aligned in the P4s payload in fixed positions relative to the P4s frame and multiframe. The format of the TU-12 pointer and its location in the frame/multiframe are defined in ETS 300 337 [10].

V1, V2 - Pointer generation: The function shall generate the TU-12 pointer as is described in EN 300 417-1-1 [9], annex A: Pointer Generation. It shall insert the pointer in the appropriate V1, V2 positions with the SS field set to 10 to indicate TU-12.

NOTE 3: The byte V4 is undefined.

TU-12 timeslot: The adaptation source function has access to a specific TU-12 of the TUG3 access point. The TU-12 is defined by the parameters K, L and M (K=A to C, L=1 to 7, M=1 to 3).

Figure 108 shows that more than one adaptation source function exists in the TUG3 layer that can be connected to one TUG access point. For such case, a subset of these adaptation source functions is allowed to be activated together, but only one adaptation source function may have access to a specific TU timeslot. Access to the same TU timeslot by other adaptation source functions shall be denied.

Activation: The function shall access the access point when it is activated (MI_Active is true). Otherwise, it shall not access the access point.

Defects: none.

Consequent actions:

aAIS ← CI_SSF

On declaration of aAIS the function shall output an all-ONEs signal within 1 ms; on clearing of aAIS the function shall output normal data within 1 ms.

NOTE 4: If CI_SSF is not connected (when connected to a S12_TT_So), CI_SSF is assumed to be false.

Defect correlations: none.

Performance monitoring: none.

9.3.1.6 TUG3 to VC-11 layer adaptation source function TUG3/S11*_A_So/K.L.M

Symbol:

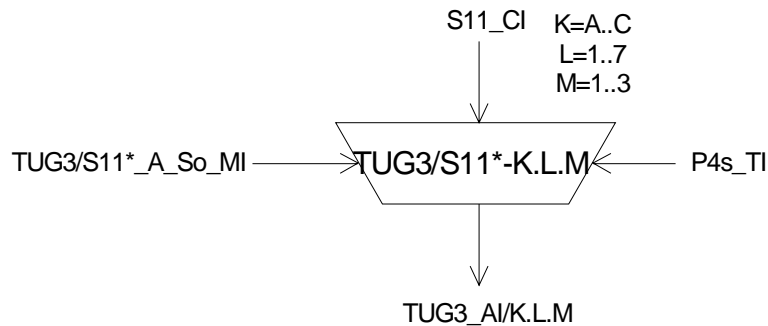

Figure 119: TUG3/S11*_A_So symbol

Interfaces:

Table 81: TUG3/S11*_A_So input and output signals

Input(s)	Output(s)
S11_CI_D	TUG3_AI_D
S11_CI_CK	TUG3_AI_CK
S11_CI_FS	TUG3_AI_FS
S11_CI_SSF	
P4s_TI_CK	
P4s_TI_FS	
P4s_TI_MFS	
TUG3/S11*_A_So_MI_Active	
NOTE 1: The TUG3/S11*_A_So functions can only be used in a P4s/SX-TUG3_A_So compound function. It can not be used as a stand alone function.	

Processes:

This function provides frequency justification and bitrate adaptation for a VC-11 signal, represented by a nominally $(104 \times 64 / 4) = 1\,664$ kbit/s information stream with a frequency accuracy within $\pm 4,6$ ppm and the related frame phase, to be multiplexed into a P4s signal. The VC-11 is transported within a TU-12; 9 bytes of fixed stuff (see figure 120) are added per 125 μ s to the VC-11 as specified by ETS 300 147 [1] to map the VC-11 into the TU-12 payload (see note 2).

NOTE 1: Mapping a VC-11 into a TU-12 allows the VC-11 signal to be transported in a VC-12 based network (via S12_C and TUG/S12_A functions) and to non-intrusively monitor this VC-11 by means of a VC-12 non-intrusive monitor (S12m_TT_Sk). The TUG3/S11*_A function will be used at the junction of VC-11 and VC-12 networks.

NOTE 2: Degraded performance may be observed when interworking with SONET equipment having a ± 20 ppm network element clock source.

The (500 μ s) frame phase of the VC-11 is coded in the related TU-12 pointer. Frequency justification, if required, is performed by pointer adjustments. The accuracy of this coding process is specified below. Refer to annex A of EN 300 417-4-1 [11].

Frequency justification and bitrate adaptation: The function shall provide an elastic store (buffer) process. The data and frame start signals shall be written into the buffer under control of the associated input clock. The data and frame start signals shall be read out of the buffer under control of the P4s clock, frame position, and justification decision.

The justification decisions determine the phase error introduced by the TUG3/S11*_A_So function. The amount of this phase error can be measured at the physical interfaces by monitoring the TU-12 pointer actions. An example is given in clause A.2 of EN 300 417-4-1 [11].

Each justification decision results in a corresponding negative/positive justification action. Upon a positive justification action, the reading of 8 data bits shall be cancelled once and no data are written at the justification opportunity position V3+1 (see figure 120). Upon a negative justification action, an extra 8 data bits shall be read out once into the justification opportunity position V3.

NOTE 3: A requirement for maximum introduced phase error cannot be defined until a reference path is defined from which the requirements for network elements can be deduced. Such a requirement would also limit excessive phase error caused by pointer processors under fixed frequency offset conditions.

Buffer size: For further study.

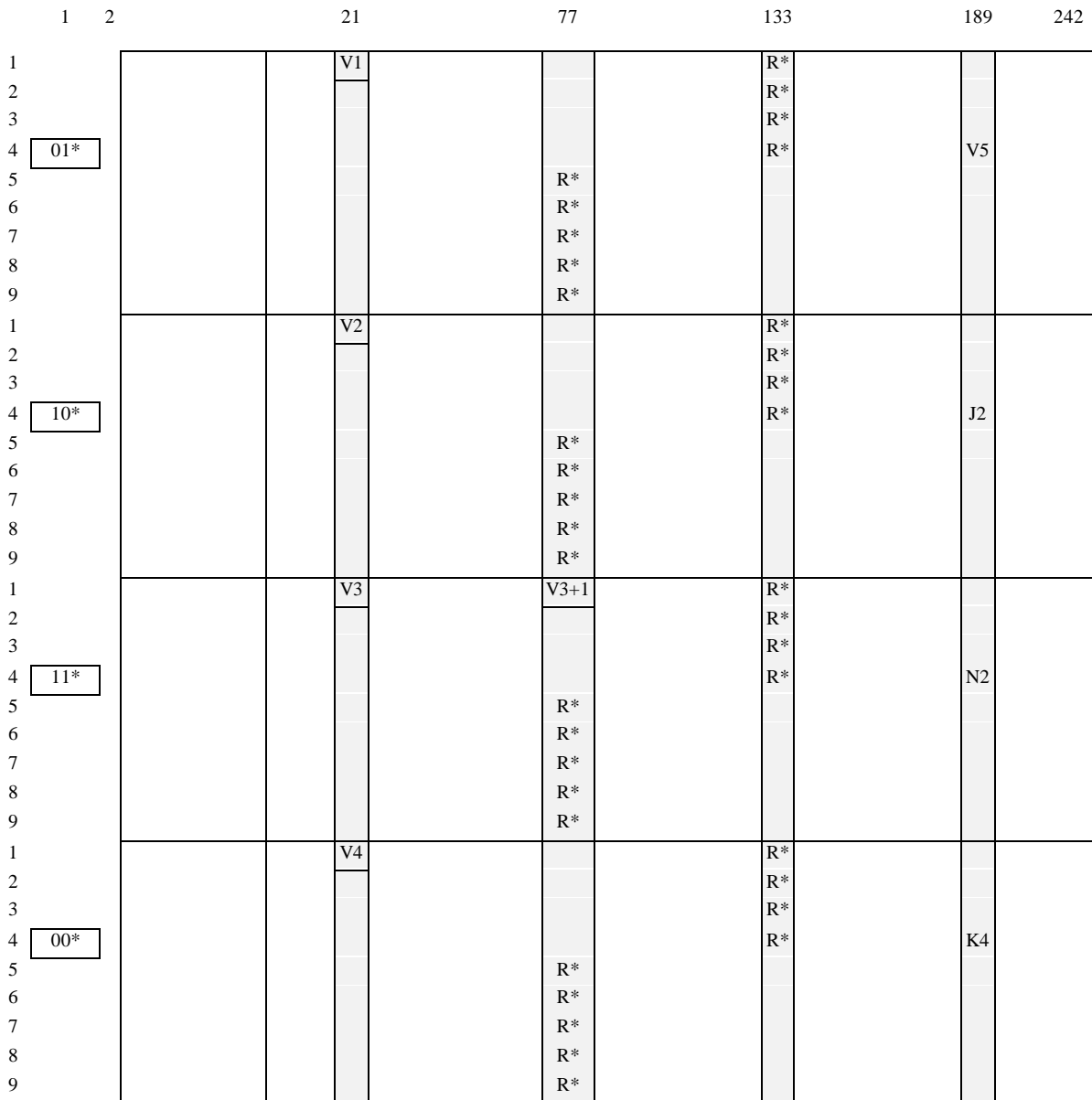

indicates the 144 bytes belonging to the TU-12 (A,2,1)
 01*, 10*, 11*, and 00* indicate code value in bits MA[6-7]
 R* indicates fixed stuff with even parity
 The positions of the V5, J2, N2, K4 and R* bytes is relative to the position of the VC-11 in the TU-12.
 The start of the VC-11 (V5 byte) is defined by the TU-12 pointer.

Figure 120: TUG3_AI_D/A.2.1 signal

The TU-12 pointer is carried in bytes V1 and V2 of payload specific OH per 500 μs multiframe (see figure 120). The TU-12 pointer is aligned in the P4s payload in fixed positions relative to the P4s frame and multiframe. The format of the TU-12 pointer and its location in the frame/multiframe are defined in ETS 300 337 [10].

V1, V2 - Pointer generation: The function shall generate the TU-12 pointer as is described in EN 300 417-1-1 [9], annex A: Pointer Generation. It shall insert the pointer in the appropriate V1, V2 positions with the SS field set to 10 to indicate TU-12.

NOTE 4: The byte V4 is undefined.

TU-12 timeslot: The adaptation source function has access to a specific TU-12 of the TUG access point. The TU-12 is defined by the parameters K, L and M (K=A to C, L=1 to 7, M=1 to 3).

Figure 108 shows that more than one adaptation source function exists in the TUG3 virtual sub-layer that can be connected to one TUG3 access point. For such case, a subset of these adaptation source functions is allowed to be activated together, but only one adaptation source function may have access to a specific TU timeslot. Access to the same TU timeslot by other adaptation source functions shall be denied.

Activation: The function shall access the access point when it is activated (MI_Active is true). Otherwise, it shall not access the access point.

Defects: none.

Consequent actions:

aAIS ← CI_SSF

On declaration of aAIS the function shall output an all-ONEs signal within 1 ms; on clearing of aAIS the function shall output normal data within 1 ms.

Defect correlations: none.

Performance monitoring: none.

9.3.2 P4s layer to VC-3, VC-2, VC-12, and VC-11 layer compound adaptation sink function P4s/SX-TUG3_A_Sk

Symbol:

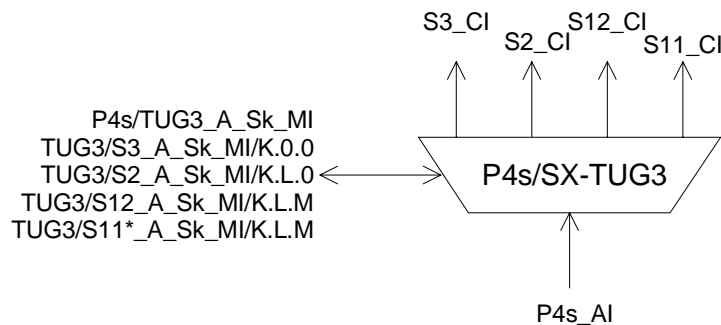

Figure 121: P4s/TUG3_A_Sk symbol

Interfaces:

Table 82: P4s/TUG3_A_Sk input and output signals

Input(s)	Output(s)
P4s_AI	P4s/TUG3_A_Sk_MI
P4s/TUG3_A_Sk_MI	maximum 2 outputs: S3_CI TUG3/S3_A_Sk_MI/K.0.0
maximum 2 inputs: TUG3/S3_A_Sk_MI/K.0.0	maximum 19 outputs: S2_CI TUG3/S2_A_Sk_MI/K.L.0
maximum 19 inputs: TUG3/S2_A_Sk_MI/K.L.0	maximum 57 outputs: S12_CI TUG3/S12_A_Sk_MI/K.L.M
maximum 57 inputs: TUG3/S12_A_Sk_MI/K.L.M	maximum 57 outputs: S11_CI TUG3/S11*_A_Sk_MI/K.L.M
maximum 57 inputs: TUG3/S11*_A_Sk_MI/K.L.M	

Processes:

The P4s/SX_A_Sk compound function provides adaptation from the P4s layer to the VC-3/2/12 layers. This process is performed by a combination of several atomic functions as shown in figure 122. The P4s/TUG3_A_Sk function performs the P4s layer specific signal label and multiframe processing, while the TUG3/S3_A_Sk, TUG3/S2_A_Sk, TUG3/S12_A_Sk and TUG3/S11*_A_Sk functions perform the lower order VC specific frequency justification and bitrate adaptation. Each of these TUG3/Sm_A_Sk functions is characterized by the K.L.M parameters, which define the number of the TU within the P4s the function has access to (TU numbering scheme according to figure B-1). According to the TUG3 multiplex structures supported by the NE, a variety of possible combinations of these TUG3/Sm_A_Sk functions exists. Table 83 lists all possible TUG3/Sm_A_Sk functions within a P4s/SX-TUG3_A_Sk compound functions.

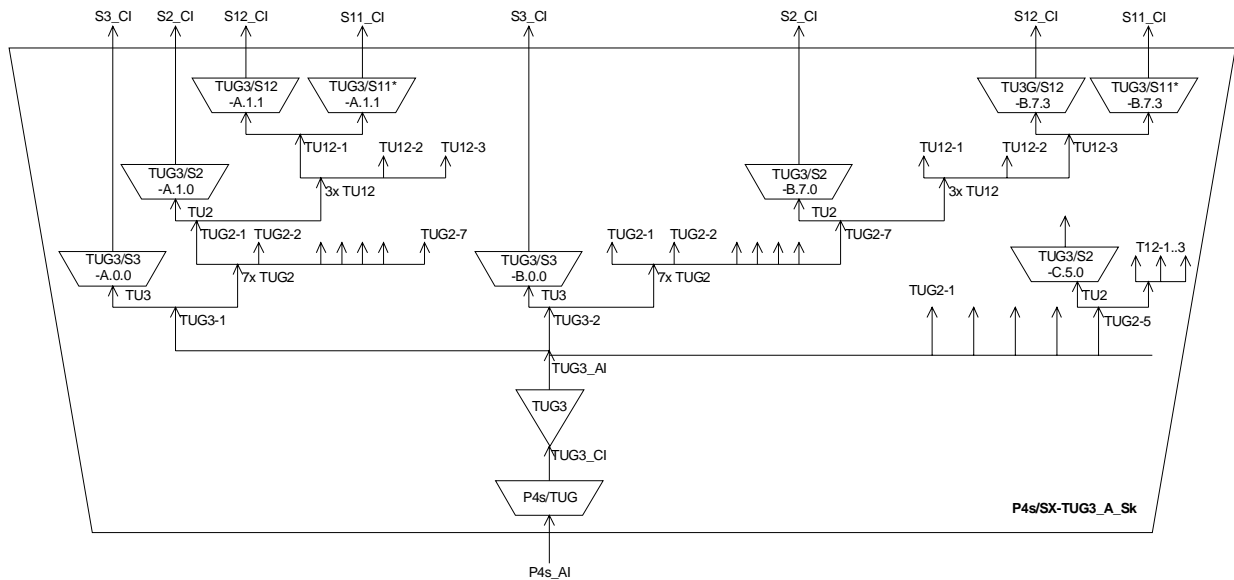

Figure 122: P4s/SX-TUG3_A_Sk compound function with set of TUG3/Sm_A_Sk atomic functions

Table 83: Possible TUG3/Sm_A_Sk functions of a P4s/SX-TUG3_A_Sk compound function

Atomic function	TU-3/TUG-3 number K	TU-2/TUG-2 number L	TU-12 number M
TUG3/S3_A_Sk/K.0.0	A,B	0	0
TUG3/S2_A_Sk/K.L.0	A,B,C	1 to 7 (A,B) 1 to 5 (C)	0
TUG3/S12_A_Sk/K.L.M	A,B,C	1 to 7 (A,B) 1 to 5 (C)	1 to 3
TUG3/S11*_A_Sk/K.L.M	A,B,C	1 to 7 (A,B) 1 to 5 (C)	1 to 3

For specific implementations only a subset of these TUG3/Sm_A_Sk functions may be used (e.g. a terminal multiplexer with fixed 2 Mbit/s access has 63 TUG3/S12_A_Sk functions). If a flexible TUG3 multiplex structure is supported, several TUG3/Sm_A_Sk functions may have access to the same TU timeslot. In contradiction with the source direction, adaptation sink functions may be activated all together. This will presumably cause faults (e.g. cLOP) to be detected and reported. To prevent this an adaptation sink function can be deactivated. This is controlled by the equipment management function by activating/deactivating the functions according to the configured TUG3 multiplex structure.

NOTE 1: The P4s/TUG3_A_Sk, TUG3_T_Sk and TUG3/Sm_A_Sk (m = 3, 2, 12, 11*) defined in the following clauses can only be used in a P4s/SX-TUG3_A_Sk compound function. These functions can not be used as stand alone functions.

NOTE 2: The TUG3 is a virtual sub-layer only applicable in a P4s/SX-TUG3_A compound function.

9.3.2.1 P4s layer to TUG3 adaptation sink function P4s/TUG3_A_Sk

Symbol:

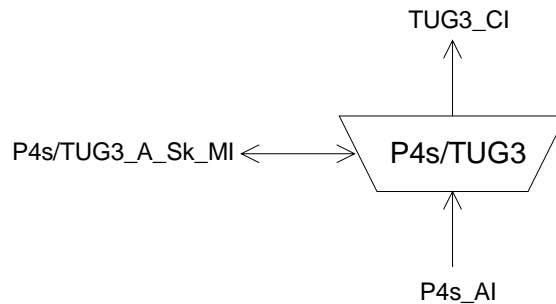

Figure 123: P4s/TUG3_A_Sk symbol

Interfaces:

Table 84: P4s/TUG3_A_Sk input and output signals

Input(s)	Output(s)
P4s_AI_D	TUG3_CI_D
P4s_AI_CK	TUG3_CI_CK
P4s_AI_FS	TUG3_CI_FS
P4s_AI_TSF	TUG3_CI_MFS
P4s/TUG3_A_Sk_MI_Active	TUG3_CI_SSF_TUG2
	TUG3_CI_SSF_TU3
	P4s/TUG3_A_Sk_MI_cPLM
	P4s/TUG3_A_Sk_MI_cLOM
NOTE: The P4s/TUG3_A_Sk function can only be used in a P4s/SX-TUG3_A_Sk compound function. It can not be used as a stand alone function.	

Processes:

The function monitors two payload specific signals (bits 3-5 and bits 6-7) of the P4s POH.

MA[3-5]: The function shall compare the content of the accepted bits 3 to 5 of byte MA with the expected value code "100" (SDH elements mapping II: $2 \times$ TUG-3 and $5 \times$ TUG-2 structure) as a check on consistency between the provisioning operation at each end. The application, acceptance and mismatch detection processes are described in EN 300 417-1-1 [9], clauses 7.2 and 8.1.2.

MA[6-7]: The function shall recover the 500 μ s (multi)frame start phase performing multi-frame alignment on bits 6 and 7 of byte MA. Out-of-multiframe (OOM) shall be assumed once when an error is detected in the MA bit 6 and 7 sequence. Multiframe alignment shall be assumed to be recovered, and the inmultiframe (IM) state shall be entered, when in four consecutive P4s frames an error free MA bit 6,7 sequence is found.

Activation: The function shall perform the operation specified above when it is activated (MI_Active is true). Otherwise, it shall activate the SSF signals at its output (CI_SSF_TU3 and CI_SSF_TUG2) and not report its status via the management point.

Defects:

The function shall detect for the dPLM defect as specified in EN 300 417-1-1 [9], clause 8.2.1.

If the multiframe alignment process is in the OOM state and the MA multiframe is not recovered within X ms, a dLOM defect shall be declared. Once in a dLOM state, this state shall be exited when the multiframe is recovered (multiframe alignment process enter the IM state). X shall be a value in the range 1 to 5 (ms). X is not configurable.

Consequent actions:

aSSF_TU3 ← dPLM
 aSSF_TUG2 ← dPLM or dLOM

Defect correlations:

cPLM ← dPLM and (not AI_TSF)
 cLOM ← dLOM and (not AI_TSF) and (not dPLM)

NOTE: There may be another parallel adaptation function, e.g. P31s/SD_A_Sk that generate also cLOM. The EMF should take care that fLOM is reported only once.

Performance monitoring: none.

9.3.2.2 TUG3 trail termination sink function TUG3_T_Sk

Symbol:

Figure 124: TUG3_T_Sk symbol

Interfaces:

Table 85: TUG3_T_Sk input and output signals

Input(s)	Output(s)
TUG3_CI_D	TUG3_AI_D
TUG3_CI_CK	TUG3_AI_CK
TUG3_CI_FS	TUG3_AI_FS
TUG3_CI_SSF_TUG2	TUG3_AI_TSF_TUG2
TUG3_CI_SSF_TU3	TUG3_AI_TSF_TU3
NOTE: The TUG3_T_Sk function can only be used in a P4s/SX-TUG3_A_Sk compound function. It can not be used as a stand alone function.	

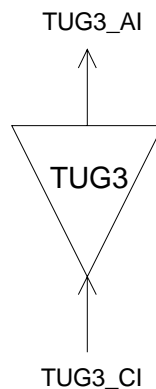
Processes: none.

Defects: none.

Consequent actions:

aTSF_TUG2 ← CI_SSF_TUG2

aTSF_TU3 ← CI_SSF_TU3

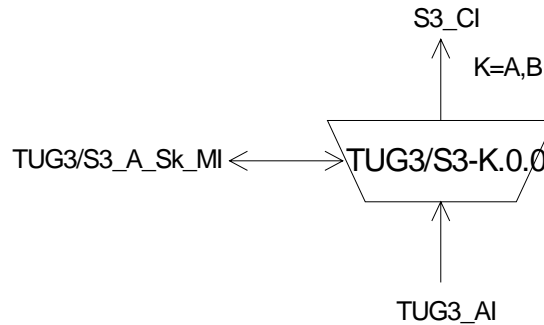
Defect correlations: none.**Performance monitoring:** none.**9.3.2.3 TUG3 to VC-3 layer adaptation sink function TUG3/S3_A_Sk/K.0.0****Symbol:****Figure 125: TUG3/S3_A_Sk symbol****Interfaces:****Table 86: TUG3/S3_A_Sk input and output signals**

Input(s)	Output(s)
TUG3_AI_D	S3_CI_D
TUG3_AI_CK	S3_CI_CK
TUG3_AI_FS	S3_CI_FS
TUG3_AI_TSF_TU3	S3_CI_SSF
TUG3/S3_A_Sk_MI_AIS_Reported	TUG3/S3_A_Sk_MI_cLOP
TUG3/S3_A_Sk_MI_Active	TUG3/S3_A_Sk_MI_cAIS
NOTE: The TUG3/S3_A_Sk function can only be used in a P4s/SX-TUG3_A_Sk compound function. It can not be used as a stand alone function.	

Processes:

This function recovers the VC-3 data with frame phase information from a TU-3.

H1, H2 - TU-3 pointer interpretation: The function shall perform TU-3 pointer interpretation as specified in annex B in EN 300 417-1-1 [9] to recover the VC-3 frame phase within a TU-3 of a P4s.

TU-3 timeslot: The adaptation source function has access to a specific TU-3 of the TUG3 access point. The TU-3 is defined by the parameter K (K=A,B).

Figure 122 shows that more than one adaptation sink function exists in this TUG3 virtual sub-layer that can be connected to one TUG3 access point. In contradiction with the source direction, adaptation sink functions may be activated all together. This will presumably cause faults (e.g. cLOP) to be detected and reported. To prevent this an adaptation sink function can be deactivated.

Activation: The function shall perform the operation specified above when it is activated (MI_Active is true). Otherwise, it shall transmit the all-ONES signal at its output (CI_D) and not report its status via its management point.

Defects:

The function shall detect for dAIS and dLOP defects according the algorithm described under the pointer interpreter process in EN 300 417-1-1 [9], annex B, Pointer Interpretation.

Consequent actions:

aAIS ← dAIS or dLOP or AI_TSF_TU3

aSSF ← dAIS or dLOP or AI_TSF_TU3

On declaration of aAIS the function shall output an all-ONEs (AIS) signal within 250 µs; on clearing of aAIS the function shall output the recovered data within 250 µs.

Defect correlations:

cAIS ← dAIS and (not AI_TSF_TU3) and AIS_Reported

cLOP ← dLOP and (not AI_TSF_TU3)

It shall be an option to report AIS as a fault cause. This is controlled by means of the parameter AIS_Reported. The default shall be AIS_Reported = false.

Performance monitoring: none.

9.3.2.4 TUG3 to VC-2 layer adaptation sink function TUG3/S2_A_Sk

Symbol:

Figure 126: TUG3/S2_A_Sk symbol

Interfaces:

Table 87: TUG3/S2_A_Sk input and output signals

Input(s)	Output(s)
TUG3_AI_D	S2_CI_D
TUG3_AI_CK	S2_CI_CK
TUG3_AI_FS	S2_CI_FS
TUG3_AI_TSF_TUG2	S2_CI_SSF
TUG3/S2_A_Sk_MI_AIS_Reported	TUG3/S2_A_Sk_MI_cLOP
TUG3/S2_A_Sk_MI_Active	TUG3/S2_A_Sk_MI_cAIS
NOTE: The TUG3/S2_A_Sk function can only be used in a P4s/SX-TUG3_A_Sk compound function. It can not be used as a stand alone function.	

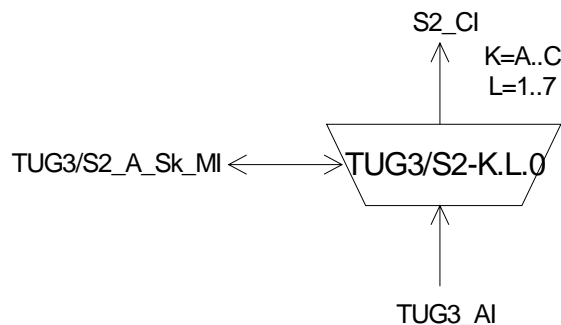
Processes:

This function recovers VC-2 data with frame phase information from a TU-2.

V1, V2 - TU-2 pointer interpretation: The function shall perform TU-2 pointer interpretation as specified in annex B in EN 300 417-1-1 [9] to recover the VC-2 frame phase within a TU-2 of a P4s.

Defects:

The function shall detect for dAIS and dLOP defect according the algorithm described under the pointer interpreter process in EN 300 417-1-1 [9], annex B, Pointer Interpretation.

TU-2 timeslot: The adaptation source function has access to a specific TU-2 of the TUG access point. The TU-2 is defined by the parameters K and L (K=A,B, L=1 to 7 and K=C, L=1 to 5).

Figure 122 shows that more than one adaptation sink function exists in this TUG3 virtual sub-layer that can be connected to one TUG access point. In contradiction with the source direction, adaptation sink functions may be activated all together. This will presumably cause faults (e.g. cLOP) to be detected and reported. To prevent this an adaptation sink function can be deactivated.

Activation: The function shall perform the operation specified above when it is activated (MI_Active is true). Otherwise, it shall transmit the all-ONEs signal at its output (CI_D) and not report its status via its management point.

Consequent actions:

aAIS ← dAIS or dLOP or AI_TSF_TUG2

aSSF ← dAIS or dLOP or AI_TSF_TUG2

On declaration of aAIS the function shall output all-ONEs signal within 1 ms; on clearing of aAIS the function shall output the recovered data within 1 ms.

Defect correlations:

cAIS ← dAIS and (not AI_TSF_TUG2) and AIS_Reported

cLOP ← dLOP and (not AI_TSF_TUG2)

It shall be an option to report AIS as a fault cause. This is controlled by means of the parameter AIS_Reported. The default shall be AIS_Reported = false.

Performance monitoring: none.

9.3.2.5 TUG3 to VC-12 layer adaptation sink function TUG3/S12_A_Sk/K.L.M

Symbol:

Figure 127: TUG3/S12_A_Sk symbol

Interfaces:**Table 88: TUG3/S12_A_Sk input and output signals**

Input(s)	Output(s)
TUG3_AI_D	S12_CI_D
TUG3_AI_CK	S12_CI_CK
TUG3_AI_FS	S12_CI_FS
TUG3_AI_TSF_TUG2	S12_CI_SSF
TUG3/S12_A_Sk_MI_AIS_Reported	TUG3/S12_A_Sk_MI_cLOP
TUG3/S12_A_Sk_MI_Active	TUG3/S12_A_Sk_MI_cAIS
NOTE: The TUG3/S12_A_Sk functions can only be used in a P4s/SX-TUG3_A_Sk compound function. It can not be used as a stand alone function.	

Processes:

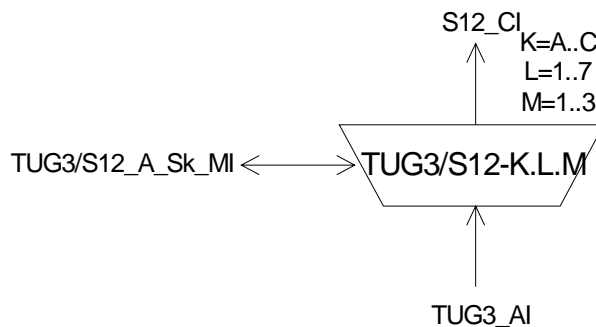
This function recovers VC-12 data with frame phase information from a TU-12.

V1, V2 - TU-12 pointer interpretation: The function shall perform TU-12 pointer interpretation as specified in annex B in EN 300 417-1-1 [9] to recover the VC-12 frame phase within a TU-12 of a P4s.

TU-12 timeslot: The adaptation source function has access to a specific TU-12 of the TUG3 access point. The TU-12 is defined by the parameters K, L and M (K=A to C, L=1 to 7, M=1 to 3).

Figure 122 shows that more than one adaptation sink function exists in this TUG3 virtual sub-layer that can be connected to one TUG3 access point. In contradiction with the source direction, adaptation sink functions may be activated all together. This will presumably cause faults (e.g. cLOP) to be detected and reported. To prevent this an adaptation sink function can be deactivated.

Activation: The function shall perform the operation specified above when it is activated (MI_Active is true). Otherwise, it shall transmit the all-ONES signal at its output (CI_D) and not report its status via its management point.

Defects:

The function shall detect for dAIS and dLOP defect according the algorithm described under the pointer interpreter process in EN 300 417-1-1 [9], annex B, Pointer Interpretation.

Consequent actions:

aAIS ← dAIS or dLOP or AI_TSF_TUG2

aSSF ← dAIS or dLOP or AI_TSF_TUG2

On declaration of aAIS the function shall output all ONEs signal within 1 ms; on clearing of aAIS the function shall output the recovered data within 1 ms.

Defect correlations:

cAIS ← dAIS and (not AI_TSF_TUG2) and AIS_Reported

cLOP ← dLOP and (not AI_TSF_TUG2)

It shall be an option to report AIS as a fault cause. This is controlled by means of the parameter AIS_Reported. The default shall be AIS_Reported = false.

Performance monitoring: none.

9.3.2.6 TUG3 to VC-11 layer adaptation sink function TUG3/S11*_A_Sk/K.L.M

Symbol:

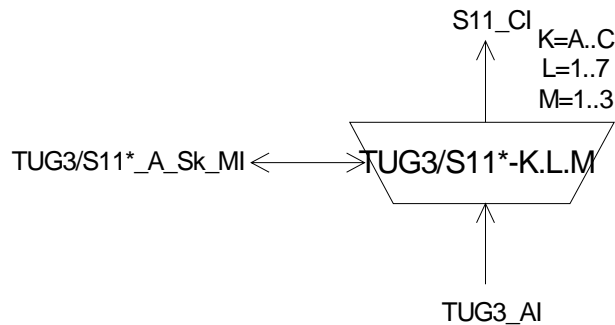

Figure 128: TUG3/S11*_A_Sk symbol

Interfaces:

Table 89: TUG3/S11*_A_Sk input and output signals

Input(s)	Output(s)
TUG3_AI_D	S11_CI_D
TUG3_AI_CK	S11_CI_CK
TUG3_AI_FS	S11_CI_FS
TUG3_AI_TSF_TUG2	S11_CI_SSF
TUG3/S11*_A_Sk_MI_AIS_Reported	TUG3/S11*_A_Sk_MI_cLOP
TUG3/S11*_A_Sk_MI_Active	TUG3/S11*_A_Sk_MI_cAIS
NOTE: The TUG3/S11*_A_Sk functions can only be used in a P4s/SX-TUG3_A_Sk compound function. It can not be used as a stand alone function.	

Processes:

This function recovers VC-11 data with frame phase information from a TU-12.

V1, V2 - TU-12 pointer interpretation: The function shall perform TU-12 pointer interpretation as specified in annex B in EN 300 417-1-1 [9] to recover the VC-11 frame phase within a TU-12 of a P4s.

TU-12 timeslot: The adaptation source function has access to a specific TU-12 of the TUG3 access point. The TU-12 is defined by the parameters K, L and M (K=A to C, L=1 to 7, M=1 to 3).

Figure 122 shows that more than one adaptation sink function exists in this TUG3 virtual sub-layer that can be connected to one TUG3 access point. In contradiction with the source direction, adaptation sink functions may be activated all together. This will presumably cause faults (e.g. cLOP) to be detected and reported. To prevent this an adaptation sink function can be deactivated.

Activation: The function shall perform the operation specified above when it is activated (MI_Active is true). Otherwise, it shall transmit the all-ONES signal at its output (CI_D) and not report its status via its management point.

Defects:

The function shall detect for dAIS and dLOP defect according the algorithm described under the pointer interpreter process in EN 300 417-1-1 [9], annex B, Pointer Interpretation.

Consequent actions:

aAIS ← dAIS or dLOP or AI_TSF_TUG2

aSSF ← dAIS or dLOP or AI_TSF_TUG2

On declaration of aAIS the function shall output all ONEs signal within 1 ms; on clearing of aAIS the function shall output the recovered data within 1 ms.

Defect correlations:

cAIS ← dAIS and (not AI_TSF_TUG2) and AIS_Reported

cLOP ← dLOP and (not AI_TSF_TUG2)

It shall be an option to report AIS as a fault cause. This is controlled by means of the parameter AIS_Reported. The default shall be AIS_Reported = false.

Performance monitoring: none.

9.3.3 P4s layer to VC-2, VC-12, and VC-11 layer compound adaptation source function P4s/SX-TUG2_A_So

Symbol:

Figure 129: P4s/SX-TUG2_A_So symbol

Interfaces:

Table 90: P4s/SX-TUG2_A_So input and output signals

Input(s)	Output(s)
P4s/TUG_A_So_MI P4s_TI	P4s_AI
maximum 20 inputs: S2_CI TUG/S2_A_So_MI/L.0	
maximum 60 inputs: S12_CI TUG/S12_A_So_MI/L.M	
maximum 60 inputs: S11_CI TUG/S11*_A_So_MI/L.M	

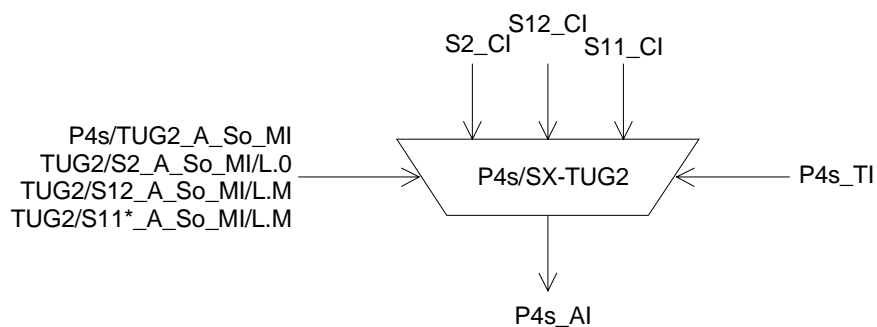
Processes:

The P4s/SX-TUG2_A_So compound function provides adaptation from the VC-/2/12/11 layers to the P4s layer. This process is performed by a combination of several atomic functions as shown in figure 130. The P4s/TUG_A_So function performs the P4s layer specific signal label and multiframe processing, while the TUG2/S2_A_So, TUG2/S12_A_So and TUG2/S11*_A_So functions perform the lower order VC specific frequency justification and bitrate adaptation. Each of these TUG2/Sm_A_So functions is characterized by the L.M parameters, which define the number of the TU within the P4s the function has access to (TU numbering scheme according to figure C-1). According to the TUG2 multiplex structures supported by the NE, a variety of possible combinations of these TUG2/Sm_A_So functions exists. Table 91 lists all possible TUG2/Sm_A_So functions within a P4s/SX-TUG2_A_So compound functions.

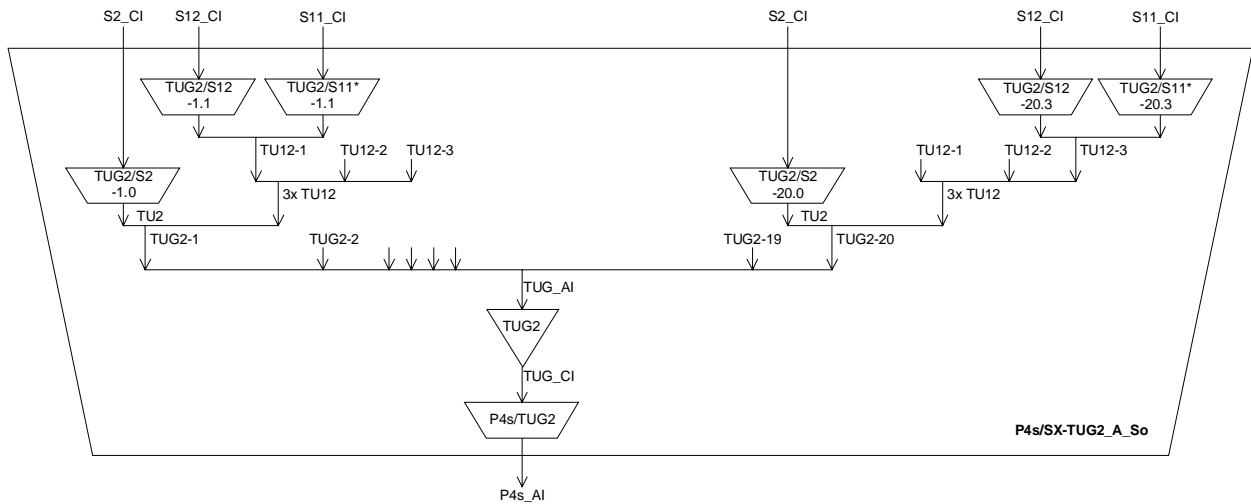

Figure 130: P4s/SX-TUG2_A_So compound function with set of TUG2/Sm_A_So atomic functions

Table 91: Possible TUG2/Sm_A_So functions of a P4s/SX-TUG2_A_So compound function

Atomic function	TU-2/TUG-2 number L	TU-12 number M
TUG2/S2_A_So/L.0	1 to 20	-
TUG2/S12_A_So/L.M	1 to 20	1 to 3
TUG2/S11*_A_So/L.M	1 to 20	1 to 3

For specific implementations only a subset of these TUG2/Sm_A_So functions may be used (e.g. a terminal multiplexer with fixed 2 Mbit/s access has 60 TUG2/S12_A_So functions). If a flexible TUG2 multiplex structure is supported, several TUG2/Sm_A_So functions may have access to the same TU timeslot. For such case, only one of these adaptation source functions is allowed to be activated. This is controlled by the equipment management function by activating/deactivating the functions according to the configured TUG2 multiplex structure.

NOTE 1: The P4s/TUG2_A_So, TUG2_T_So and TUG2/Sm_A_So (m = 2, 12, 11*) defined in the following clauses can only be used in a P4s/SX-TUG2_A_So compound function. These functions can not be used as stand alone functions.

NOTE 2: The TUG2 is a virtual sub-layer only applicable in a P4s/SX-TUG2_A compound function.

The number of TUG2/Sm_A (m=2,12,11*) functions that is active shall completely fill the P4s payload.

9.3.3.1 P4s layer to TUG2 adaptation source function P4s/TUG2_A_So

Symbol:

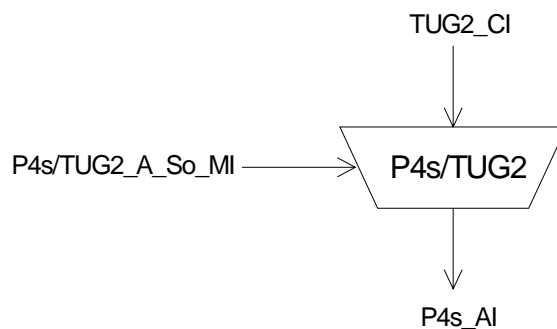

Figure 131: P4s/TUG2_A_So symbol

Interfaces:

Table 92: P4s/TUG2_A_So input and output signals

Input(s)	Output(s)
TUG2_CI_D TUG2_CI_CK TUG2_CI_FS TUG2_CI_MFS P4s/TUG2_A_So_MI_Active	P4s_AI_D P4s_AI_CK P4s_AI_FS
NOTE: The P4s/TUG2_A_So functions can only be used in a P4s/SX-TUG2_A_So compound function. It can not be used as a stand alone function.	

Processes:

The function adds two payload specific signals (bits MA[3-5] and MA[6-7]) to the P4s POH.

MA[3-5]: In this byte the function shall insert code "011" (SDH elements mapping I: 20 × TUG-2 structure) as defined in ETS 300 337 [10].

MA[6-7]: The value of the multiframe indicator MA[6-7] shall be set as specified by ETS 300 337 [10], 500 μs TU multiframe sequence, and aligned with TUG2_CI_MFS.

					TU multiframe indicator		
1	2	3	4	5	6	7	8

Figure 132: TU multiframe indicator bits in byte MA

Activation: The function shall access the access point when it is activated (MI_Active is true). Otherwise, it shall not access the access point.

Defects: none.

Consequent actions: none.

Defect correlations: none.

Performance monitoring: none.

9.3.3.2 TUG2 trail termination source function TUG2_T_So

Symbol:

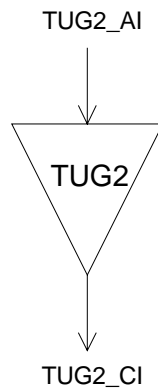

Figure 133: TUG2_T_So symbol

Interfaces:

Table 93: TUG2_T_So input and output signals

Input(s)	Output(s)
TUG2_AI_D	TUG2_CI_D
TUG2_AI_CK	TUG2_CI_CK
TUG2_AI_FS	TUG2_CI_FS
TUG2_AI_MFS	TUG2_CI_MFS
NOTE: The TUG2_T_So functions can only be used in a P4s/SX-TUG2_A_So compound function. It can not be used as a stand alone function.	

Processes: none.

Defects: none.

Consequent actions: none.

Defect correlations: none.

Performance monitoring: none.

9.3.3.3 TUG2 to VC-2 layer adaptation source function TUG2/S2_A_So/L.0

Symbol:

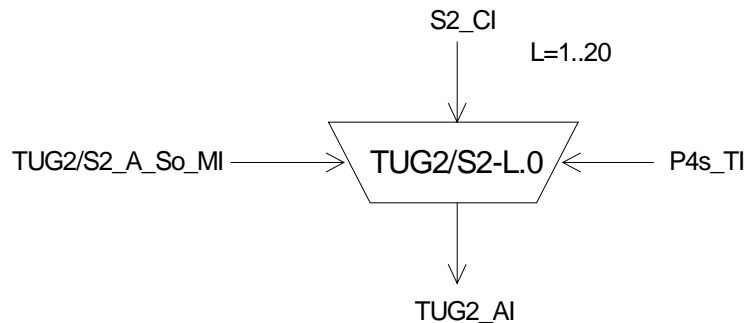

Figure 134: TUG2/S2_A_So symbol

Interfaces:

Table 94: TUG2/S2_A_So input and output signals

Input(s)	Output(s)
S2_CI_D	TUG2_AI_D
S2_CI_CK	TUG2_AI_CK
S2_CI_FS	TUG2_AI_FS
S2_CI_SSF	TUG2_AI_MFS
P4s_TI_CK	
P4s_TI_FS	
P4s_TI_MFS	
TUG2/S2_A_So_MI_Active	
NOTE: The TUG2/S2_A_So functions can only be used in a P4s/SX-TUG2_A_So compound function. It can not be used as a stand alone function.	

Processes:

This function provides frequency justification and bitrate adaptation for a VC-2 signal, represented by a nominally $(428 \times 64/4) = 6\,848$ kbit/s information stream with a frequency accuracy within $\pm 4,6$ ppm and the related frame phase, to be multiplexed into a P4s signal via a TU-2.

NOTE 1: Degraded performance may be observed when interworking with SONET equipment having a ± 20 ppm network element clock source.

The (500 μ s) frame phase of the VC-2 is coded in the related TU-2 pointer. Frequency justification, if required, is performed by pointer adjustments. The accuracy of this coding process is specified below. Refer to annex A of EN 300 417-4-1 [11].

Frequency justification and bitrate adaptation: The function shall provide an elastic store (buffer) process. The data and frame start signals shall be written into the buffer under control of the associated input clock. The data and frame start signals shall be read out of the buffer under control of the P4s clock, frame position, and justification decision.

The justification decisions determine the phase error introduced by the TUG2/S2_A_So function. The amount of this phase error can be measured at the physical interfaces by monitoring the TU-2 pointer actions. An example is given in clause A.2 of EN 300 417-4-1 [11].

Each justification decision results in a corresponding negative/positive justification action. Upon a positive justification action, the reading of 8 data bits shall be cancelled once and no data are written at the justification opportunity position V3+1 (see figure 135). Upon a negative justification action, an extra 8 data bits shall be read out once into the justification opportunity position V3.

NOTE 2: A requirement for maximum introduced phase error cannot be defined until a reference path is defined from which the requirements for network elements can be deduced. Such a requirement would also limit excessive phase error caused by pointer processors under fixed frequency offset conditions.

Buffer size: For further study.

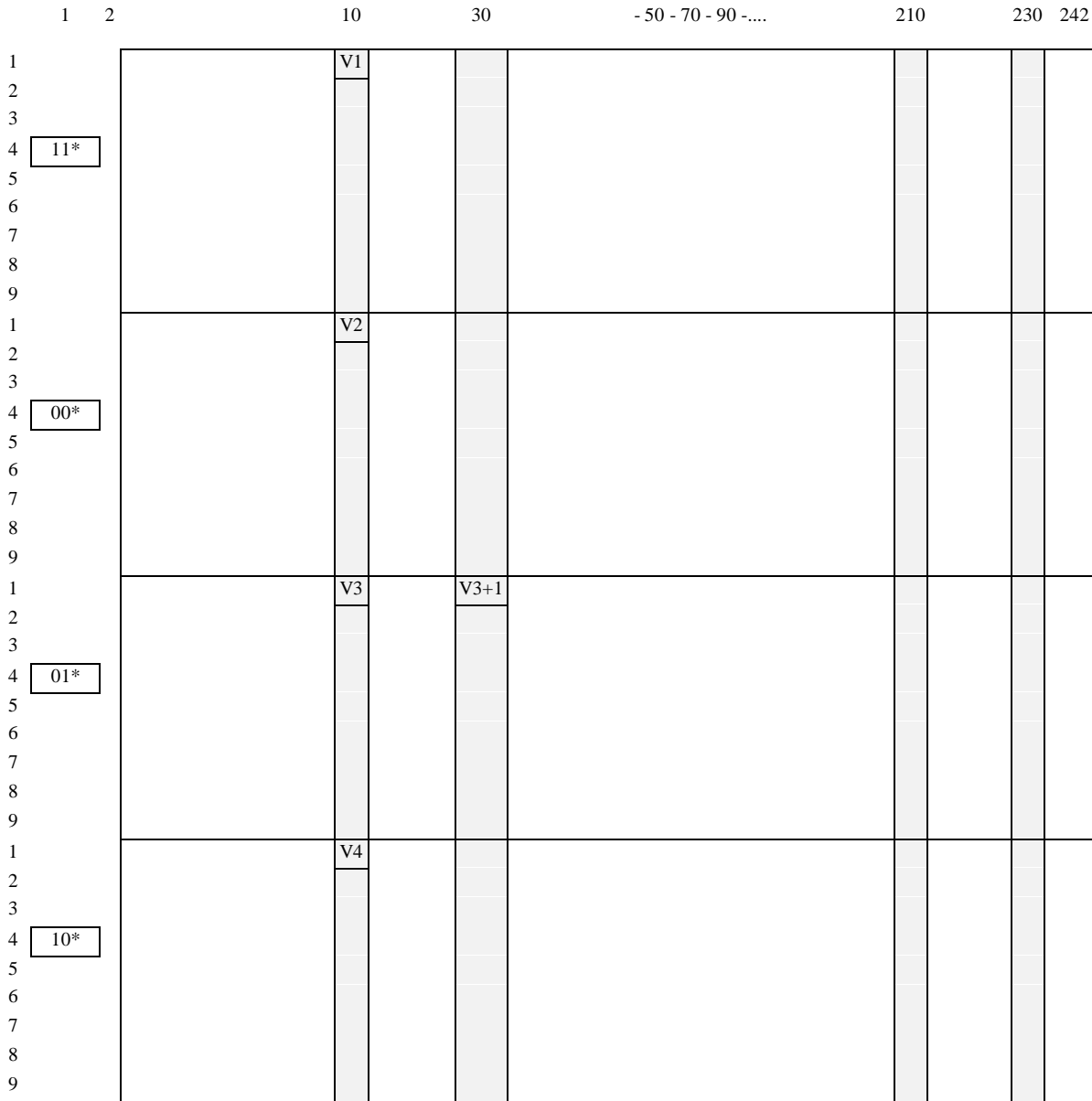

□ indicates the 432 bytes belonging to the TU-2 (8,0)
 01*, 10*, 11*, and 00* indicate code value in bits MA[6-7]

Figure 135: TUG2_AI_D/8.0 signal

The TU-2 pointer is carried in bytes V1 and V2 of payload specific OH once per 500 μs multiframe (see figure 135). The TU-2 pointer is aligned in the P4s payload in fixed positions relative to the P4s frame and multiframe. The format of the TU-2 pointer and its location in the frame/multiframe are defined in ETS 300 337 [10].

V1, V2 - Pointer generation: The function shall generate the TU-2 pointer as is described in EN 300 417-1-1 [9], annex A: Pointer Generation. It shall insert the pointer in the appropriate V1, V2 positions with the SS field set to 00 to indicate TU-2.

NOTE 3: The byte V4 is undefined.

TU-2 timeslot: The adaptation source function has access to a specific TU-2 of the TUG access point. The TU-2 is defined by the parameter L (L=1 to 20).

Figure 130 shows that more than one adaptation source function exists in the TUG2 virtual sub-layer that can be connected to one TUG2 access point. For such case, a subset of these adaptation source functions is allowed to be activated together, but only one adaptation source function may have access to a specific TU timeslot. Access to the same TU timeslot by other adaptation source functions shall be denied.

Activation: The function shall access the access point when it is activated (MI_Active is true). Otherwise, it shall not access the access point.

Defects: none.

Consequent actions:

aAIS ← CI_SSF

On declaration of aAIS the function shall output an all ONEs signal within 1 ms; on clearing of aAIS the function shall output normal data within 1 ms.

NOTE 4: If CI_SSF is not connected (when connected to a S2_TT_So), CI_SSF is assumed to be false.

Defect correlations: none.

Performance monitoring: none.

9.3.3.4 TUG2 to VC-12 layer adaptation source function TUG2/S12_A_So/L.M

Symbol:

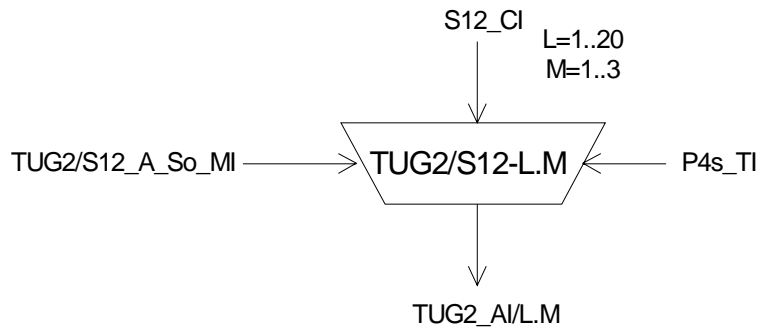

Figure 136: TUG2/S12_A_So symbol

Interfaces:

Table 95: TUG2/S12_A_So input and output signals

Input(s)	Output(s)
S12_CI_D S12_CI_CK S12_CI_FS S12_CI_SSF P4s_TI_CK P4s_TI_FS P4s_TI_MFS TUG2/S12_A_So_MI_Active	TUG2_AI_D TUG2_AI_CK TUG2_AI_FS
NOTE: The TUG2/S12_A_So functions can only be used in a P4s/SX-TUG2_A_So compound function. It can not be used as a stand alone function.	

Processes:

This function provides frequency justification and bitrate adaptation for a VC-12 signal, represented by a nominally $(140 \times 64 / 4) = 2\,240$ kbit/s information stream with a frequency accuracy within $\pm 4,6$ ppm and the related frame phase, to be multiplexed into a P4s signal via a TU-12.

NOTE 1: Degraded performance may be observed when interworking with SONET equipment having a ± 20 ppm network element clock source.

The (500 μ s) frame phase of the VC-12 is coded in the related TU-12 pointer. Frequency justification, if required, is performed by pointer adjustments. The accuracy of this coding process is specified below. Refer to annex A of EN 300 417-4-1 [11].

Frequency justification and bitrate adaptation: The function shall provide an elastic store (buffer) process. The data and frame start signals shall be written into the buffer under control of the associated input clock. The data and frame start signals shall be read out of the buffer under control of the P4s clock, frame position, and justification decision.

The justification decisions determine the phase error introduced by the TUG/S12_A_So function. The amount of this phase error can be measured at the physical interfaces by monitoring the TU-12 pointer actions. An example is given in clause A.2 of EN 300 417-4-1 [11].

Each justification decision results in a corresponding negative/positive justification action. Upon a positive justification action, the reading of 8 data bits shall be cancelled once and no data are written at the justification opportunity position V3+1 (see figure 137). Upon a negative justification action, an extra 8 data bits shall be read out once into the justification opportunity position V3.

NOTE 2: A requirement for maximum introduced phase error cannot be defined until a reference path is defined from which the requirements for network elements can be deduced. Such a requirement would also limit excessive phase error caused by pointer processors under fixed frequency offset conditions.

Buffer size: For further study.

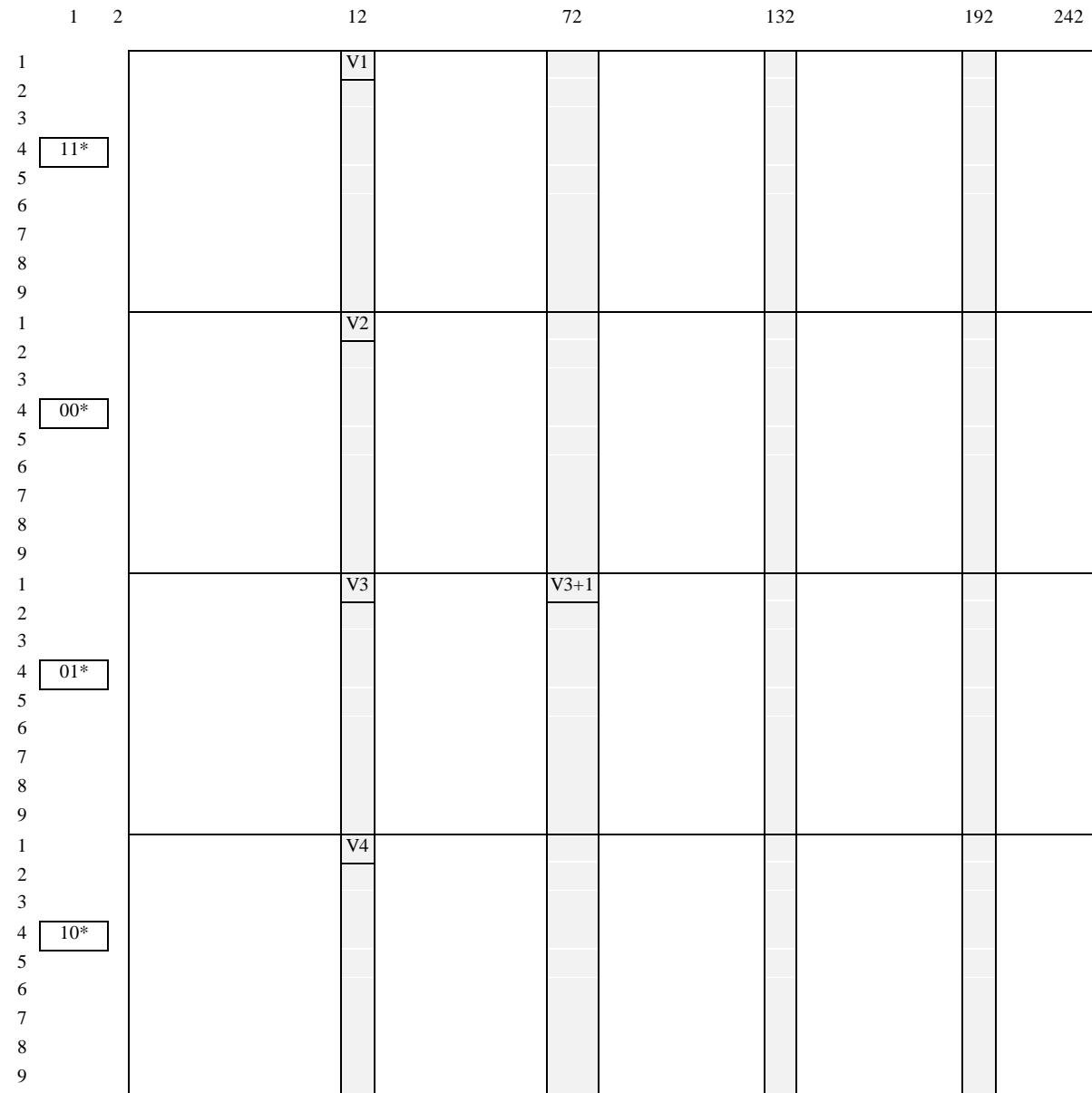

indicates the 144 bytes belonging to the TU-12 (10,1)
 01*, 10*, 11*, and 00* indicate code value in bits MA[6-7]

Figure 137: TUG2_AI_D/10.1 signal

The TU-12 pointer is carried in bytes V1 and V2 of payload specific OH per 500 μs multiframe (see figure 137). The TU-12 pointer is aligned in the P4s payload in fixed positions relative to the P4s frame and multiframe. The format of the TU-12 pointer and its location in the frame/multiframe are defined in ETS 300 337 [10].

V1, V2 - Pointer generation: The function shall generate the TU-12 pointer as is described in EN 300 417-1-1 [9], annex A: Pointer Generation. It shall insert the pointer in the appropriate V1, V2 positions with the SS field set to 10 to indicate TU-12.

NOTE 3: The byte V4 is undefined.

TU-12 timeslot: The adaptation source function has access to a specific TU-12 of the TUG2 access point. The TU-12 is defined by the parameters L and M (L=1 to 20, M=1 to 3).

Figure 130 shows that more than one adaptation source function exists in the TUG2 virtual sub-layer that can be connected to one TUG2 access point. For such case, a subset of these adaptation source functions is allowed to be activated together, but only one adaptation source function may have access to a specific TU timeslot. Access to the same TU timeslot by other adaptation source functions shall be denied.

Activation: The function shall access the access point when it is activated (MI_Active is true). Otherwise, it shall not access the access point.

Defects: none.

Consequent actions:

aAIS ← CI_SSF

On declaration of aAIS the function shall output an all-ONEs signal within 1 ms; on clearing of aAIS the function shall output normal data within 1 ms.

NOTE 4: If CI_SSF is not connected (when connected to a S12_TT_So), CI_SSF is assumed to be false.

Defect correlations: none.

Performance monitoring: none.

9.3.3.5 TUG2 to VC-11 layer adaptation source function TUG2/S11*_A_So/L.M

Symbol:

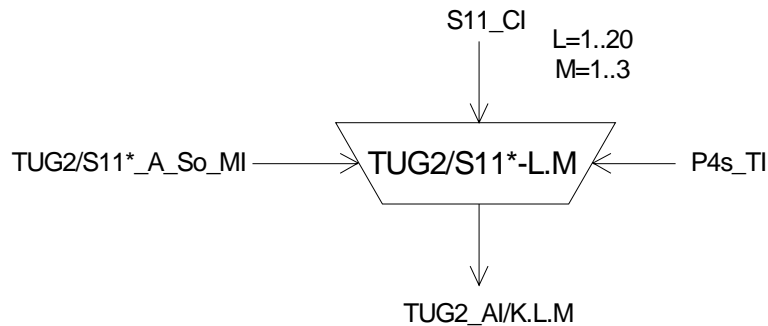

Figure 138: TUG2/S11*_A_So symbol

Interfaces:

Table 96: TUG2/S11*_A_So input and output signals

Input(s)	Output(s)
S11_CI_D	TUG2_AI_D
S11_CI_CK	TUG2_AI_CK
S11_CI_FS	TUG2_AI_FS
S11_CI_SSF	
P4s_TI_CK	
P4s_TI_FS	
P4s_TI_MFS	
TUG2/S11*_A_So_MI_Active	
NOTE: The TUG2/S11*_A_So functions can only be used in a P4s/SX-TUG2_A_So compound function. It can not be used as a stand alone function.	

Processes:

This function provides frequency justification and bitrate adaptation for a VC-11 signal, represented by a nominally $(104 \times 64 / 4) = 1\,664$ kbit/s information stream with a frequency accuracy within $\pm 4,6$ ppm and the related frame phase, to be multiplexed into a P4s signal. The VC-11 is transported within a TU-12; 9 bytes of fixed stuff (see figure 139) are added per 125 μ s to the VC-11 as specified by ETS 300 147 [1] to map the VC-11 into the TU-12 payload (see note 2).

NOTE 1: Mapping a VC-11 into a TU-12 allows the VC-11 signal to be transported in a VC-12 based network (via S12_C and TUG/S12_A functions) and to non-intrusively monitor this VC-11 by means of a VC-12 non-intrusive monitor (S12m_TT_Sk). The TUG2/S11*_A function will be used at the junction of VC-11 and VC-12 networks.

NOTE 2: Degraded performance may be observed when interworking with SONET equipment having a ± 20 ppm network element clock source.

The (500 μ s) frame phase of the VC-11 is coded in the related TU-12 pointer. Frequency justification, if required, is performed by pointer adjustments. The accuracy of this coding process is specified below. Refer to annex A of EN 300 417-4-1 [11].

Frequency justification and bitrate adaptation: The function shall provide an elastic store (buffer) process. The data and frame start signals shall be written into the buffer under control of the associated input clock. The data and frame start signals shall be read out of the buffer under control of the P4s clock, frame position, and justification decision.

The justification decisions determine the phase error introduced by the TUG2/S11*_A_So function. The amount of this phase error can be measured at the physical interfaces by monitoring the TU-12 pointer actions. An example is given in clause A.2 of EN 300 417-4-1 [11].

Each justification decision results in a corresponding negative/positive justification action. Upon a positive justification action, the reading of 8 data bits shall be cancelled once and no data are written at the justification opportunity position V3+1 (see figure 139). Upon a negative justification action, an extra 8 data bits shall be read out once into the justification opportunity position V3.

NOTE 3: A requirement for maximum introduced phase error cannot be defined until a reference path is defined from which the requirements for network elements can be deduced. Such a requirement would also limit excessive phase error caused by pointer processors under fixed frequency offset conditions.

Buffer size: For further study.

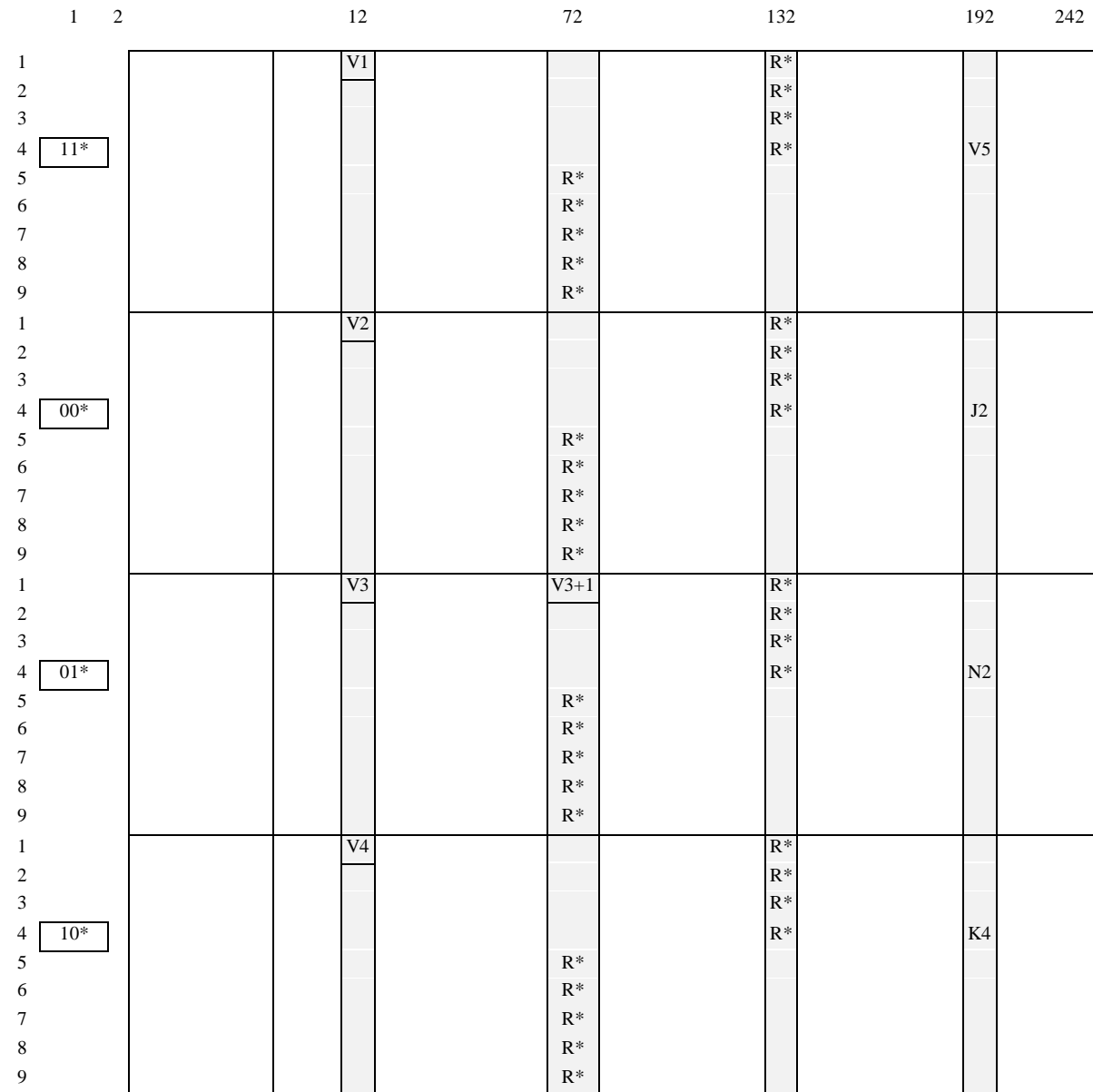

indicates the 144 bytes belonging to the TU-12 (10,1)
 01*, 10*, 11*, and 00* indicate code value in bits MA[6-7]
 R* indicates fixed stuff with even parity
 The positions of the V5, J2, N2, K4 and R^ bytes is relative to the position of the VC-11 in the TU-12.
 The start of the VC-11 (V5 byte) is defined by the TU-12 pointer.

Figure 139: TUG2_AI_D/10.1 signal

The TU-12 pointer is carried in bytes V1 and V2 of payload specific OH per 500 μs multiframe (see figure 139). The TU-12 pointer is aligned in the P4s payload in fixed positions relative to the P4s frame and multiframe. The format of the TU-12 pointer and its location in the frame/multiframe are defined in ETS 300 337 [10].

V1, V2 - Pointer generation: The function shall generate the TU-12 pointer as is described in EN 300 417-1-1 [9], annex A: Pointer Generation. It shall insert the pointer in the appropriate V1, V2 positions with the SS field set to 10 to indicate TU-12.

NOTE 4: The byte V4 is undefined.

TU-12 timeslot: The adaptation source function has access to a specific TU-12 of the TUG access point. The TU-12 is defined by the parameters L and M (L=1 to 20, M=1 to 3).

Figure 130 shows that more than one adaptation source function exists in the TUG virtual sub-layer that can be connected to one TUG access point. For such case, a subset of these adaptation source functions is allowed to be activated together, but only one adaptation source function may have access to a specific TU timeslot. Access to the same TU timeslot by other adaptation source functions shall be denied.

Activation: The function shall access the access point when it is activated (MI_Active is true). Otherwise, it shall not access the access point.

Defects: none.

Consequent actions:

aAIS ← CI_SSF

On declaration of aAIS the function shall output an all-ONEs signal within 1 ms; on clearing of aAIS the function shall output normal data within 1 ms.

Defect correlations: none.

Performance monitoring: none.

9.3.4 P4s layer to VC-2, VC-12, and VC-11 layer compound adaptation sink function P4s/SX-TUG2_A_Sk

Symbol:

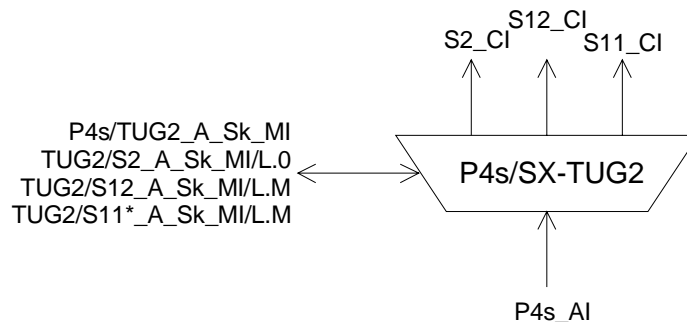

Figure 140: P4s/SX-TUG2_A_Sk symbol

Interfaces:

Table 97: P4s/SX-TUG2_A_Sk input and output signals

Input(s)	Output(s)
P4s_AI	P4s/TUG2_A_Sk_MI
P4s/TUG2_A_Sk_MI	maximum 20 outputs: S2_CI TUG2/S2_A_Sk_MI/L.0
maximum 20 inputs: TUG2/S2_A_Sk_MI/L.0	maximum 60 outputs: S12_CI TUG2/S12_A_Sk_MI/L.M
maximum 60 inputs: TUG2/S12_A_Sk_MI/L.M	maximum 60 outputs: S11_CI TUG2/S11*_A_Sk_MI/L.M
maximum 60 inputs: TUG2/S11*_A_Sk_MI/L.M	

Processes:

The P4s/SX-TUG2_A_Sk compound function provides adaptation from the P4s layer to the VC-2/12 layers. This process is performed by a combination of several atomic functions as shown in figure 141. The P4s/TUG2_A_Sk function performs the P4s layer specific signal label and multiframe processing, while the TUG2/S2_A_Sk, TUG2/S12_A_Sk and TUG2/S11*_A_Sk functions perform the lower order VC specific frequency justification and bitrate adaptation. Each of these TUG2/Sm_A_Sk functions is characterized by the K.L.M parameters, which define the number of the TU within the P4s the function has access to (TU numbering scheme according to figure C-1). According to the TUG multiplex structures supported by the NE, a variety of possible combinations of these TUG2/Sm_A_Sk functions exists. Table 98 lists all possible TUG2/Sm_A_Sk functions within a P4s/SX-TUG2_A_Sk compound functions.

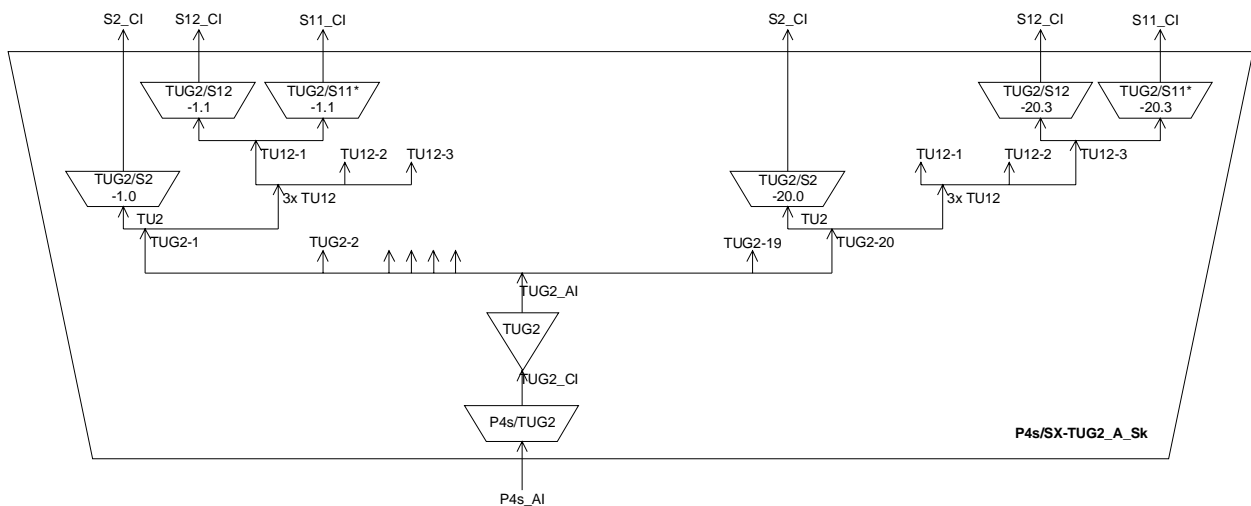

Figure 141: P4s/SX-TUG2_A_Sk compound function with set of TUG2/Sm_A_Sk atomic functions

Table 98: Possible TUG2/Sm_A_Sk functions of a P4s/SX-TUG2_A_Sk compound function

Atomic function	TU-2/TUG-2 number L	TU-12 number M
TUG2/S2_A_Sk/L.0	1 to 20	0
TUG2/S12_A_Sk/L.M	1 to 20	1 to 3
TUG2/S11*_A_Sk/L.M	1 to 20	1 to 3

For specific implementations only a subset of these TUG2/Sm_A_Sk functions may be used (e.g. a terminal multiplexer with fixed 2 Mbit/s access has 60 TUG2/S12_A_Sk functions). If a flexible TUG2 multiplex structure is supported, several TUG2/Sm_A_Sk functions may have access to the same TU timeslot. In contradiction with the source direction, adaptation sink functions may be activated all together. This will presumably cause faults (e.g. cLOP) to be detected and reported. To prevent this an adaptation sink function can be deactivated. This is controlled by the equipment management function by activating/deactivating the functions according to the configured TUG multiplex structure.

NOTE 1: The P4s/TUG2_A_Sk, TUG2_T_Sk and TUG2/Sm_A_Sk ($m = 2, 12, 11^*$) defined in the following clauses can only be used in a P4s/SX-TUG2_A_Sk compound function. These functions can not be used as stand alone functions.

NOTE 2: The TUG2 is a virtual sub-layer only applicable in a P4s/SX-TUG2_A compound function.

9.3.4.1 P4s layer to TUG2 adaptation sink function P4s/TUG2_A_Sk

Symbol:

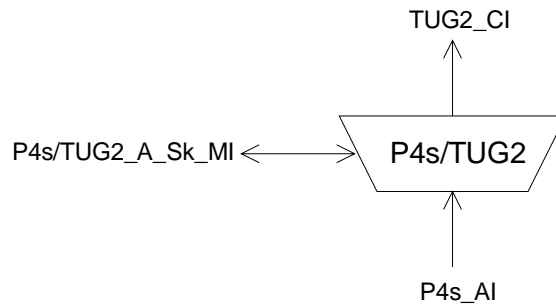

Figure 142: P4s/TUG2_A_Sk symbol

Interfaces:

Table 99: P4s/TUG2_A_Sk input and output signals

Input(s)	Output(s)
P4s_AI_D P4s_AI_CK P4s_AI_FS P4s_AI_TSF P4s/TUG2_A_Sk_MI_Active	TUG2_CI_D TUG2_CI_CK TUG2_CI_FS TUG2_CI_MFS TUG2_CI_SSF P4s/TUG2_A_Sk_MI_cPLM P4s/TUG2_A_Sk_MI_cLOM
NOTE: The P4s/TUG2_A_Sk functions can only be used in a P4s/SX-TUG2_A_Sk compound function. It can not be used as a stand alone function.	

Processes:

The function monitors two payload specific signals (bits 3-5 and bits 6-7) of the P4s POH.

MA[3-5]: The function shall compare the content of the accepted bits 3 to 5 of byte MA with the expected value code "011" (SDH elements mapping I: 20 × TUG-2 structure) as a check on consistency between the provisioning operation at each end. The application, acceptance and mismatch detection processes are described in EN 300 417-1-1 [9], clauses 7.2 and 8.1.2.

MA[6-7]: The function shall recover the 500 μs (multi)frame start phase performing multi-frame alignment on bits 6 and 7 of byte MA. Out-of-multiframe (OOM) shall be assumed once when an error is detected in the MA bit 6 and 7 sequence. Multiframe alignment shall be assumed to be recovered, and the in-multiframe (IM) state shall be entered, when in four consecutive P4s frames an error free MA bit 6,7 sequence is found.

Activation: The function shall perform the operation specified above when it is activated (MI_Active is true). Otherwise, it shall activate the SSF signals at its output (CI_SSF_TUG2) and not report its status via the management point.

Defects:

The function shall detect for the dPLM defect according EN 300 417-1-1 [9], clause 8.2.1.

If the multiframe alignment process is in the OOM state and the MA multiframe is not recovered within X ms, a dLOM defect shall be declared. Once in a dLOM state, this state shall be exited when the multiframe is recovered (multiframe alignment process enter the IM state). X shall be a value in the range 1 to 5 (ms). X is not configurable.

Consequent actions:

aSSF ← dPLM or dLOM

Defect correlations:

cPLM ← dPLM and (not AI_TSF)

cLOM ← dLOM and (not AI_TSF) and (not dPLM)

NOTE: There may be another parallel adaptation function, e.g. P4s/SD_A_Sk that generate also cLOM. The EMF should take care that fLOM is reported only once.

Performance monitoring: none.

9.3.4.2 TUG2 trail termination sink function TUG2_T_Sk

Symbol:

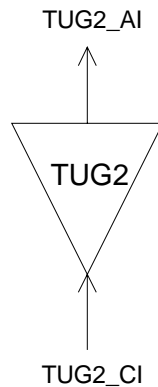

Figure 143: TUG2_T_Sk symbol

Interfaces:

Table 100: TUG2_T_Sk input and output signals

Input(s)	Output(s)
TUG2_CI_D	TUG2_AI_D
TUG2_CI_CK	TUG2_AI_CK
TUG2_CI_FS	TUG2_AI_FS
TUG2_CI_SSF	TUG2_AI_TSF
NOTE: The TUG2_T_Sk function can only be used in a P4s/SX-TUG2_A_Sk compound function. It can not be used as a stand alone function.	

Processes: none.

Defects: none.

Consequent actions:

aTSF ← CI_SSF

Defect correlations: none.

Performance monitoring: none.

9.3.4.3 TUG2 to VC-2 layer adaptation sink function TUG2/S2_A_Sk/L.0

Symbol:

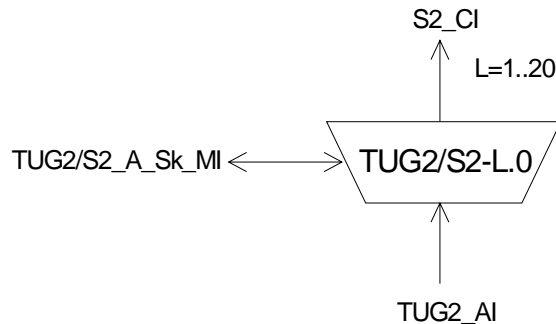

Figure 144: TUG2/S2_A_Sk symbol

Interfaces:

Table 101: TUG2/S2_A_Sk input and output signals

Input(s)	Output(s)
TUG2_AI_D	S2_CI_D
TUG2_AI_CK	S2_CI_CK
TUG2_AI_FS	S2_CI_FS
TUG2_AI_TSF	S2_CI_SSF
TUG2/S2_A_Sk_MI_AIS_Reported	TUG2/S2_A_Sk_MI_cLOP
TUG2/S2_A_Sk_MI_Active	TUG2/S2_A_Sk_MI_cAIS
NOTE: The TUG2/S2_A_Sk function can only be used in a P4s/SX-TUG2_A_Sk compound function. It can not be used as a stand alone function.	

Processes:

This function recovers VC-2 data with frame phase information from a TU-2.

V1, V2 - TU-2 pointer interpretation: The function shall perform TU-2 pointer interpretation as specified in annex B in EN 300 417-1-1 [9] to recover the VC-2 frame phase within a TU-2 of a P4s.

Defects:

The function shall detect for dAIS and dLOP defect according the algorithm described under the pointer interpreter process in EN 300 417-1-1 [9], annex B, Pointer Interpretation.

TU-2 timeslot: The adaptation source function has access to a specific TU-2 of the TUG access point. The TU-2 is defined by the parameter L (L=1 to 20).

Figure 141 shows that more than one adaptation sink function exists in this TUG2 virtual sub-layer that can be connected to one TUG2 access point. In contradiction with the source direction, adaptation sink functions may be activated all together. This will presumably cause faults (e.g. cLOP) to be detected and reported. To prevent this an adaptation sink function can be deactivated.

Activation: The function shall perform the operation specified above when it is activated (MI_Active is true). Otherwise, it shall transmit the all-ONES signal at its output (CI_D) and not report its status via its management point.

Consequent actions:

aAIS ← dAIS or dLOP or AI_TSF

aSSF ← dAIS or dLOP or AI_TSF

On declaration of aAIS the function shall output all-ONEs signal within 1 ms; on clearing of aAIS the function shall output the recovered data within 1 ms.

Defect correlations:

cAIS ← dAIS and (not AI_TSF) and AIS_Reported

cLOP ← dLOP and (not AI_TSF)

It shall be an option to report AIS as a fault cause. This is controlled by means of the parameter AIS_Reported. The default shall be AIS_Reported = false.

Performance monitoring: none.

9.3.4.4 TUG2 to VC-12 layer adaptation sink function TUG2/S12_A_Sk/L.M

Symbol:

Figure 145: TUG2/S12_A_Sk symbol

Interfaces:

Table 102: TUG2/S12_A_Sk input and output signals

Input(s)	Output(s)
TUG2_AI_D	S12_CI_D
TUG2_AI_CK	S12_CI_CK
TUG2_AI_FS	S12_CI_FS
TUG2_AI_TSF	S12_CI_SSF
TUG2/S12_A_Sk_MI_AIS_Reported	TUG2/S12_A_Sk_MI_cLOP
TUG2/S12_A_Sk_MI_Active	TUG2/S12_A_Sk_MI_cAIS
NOTE: The TUG2/S12_A_Sk functions can only be used in a P4s/SX-TUG2_A_Sk compound function. It can not be used as a stand alone function.	

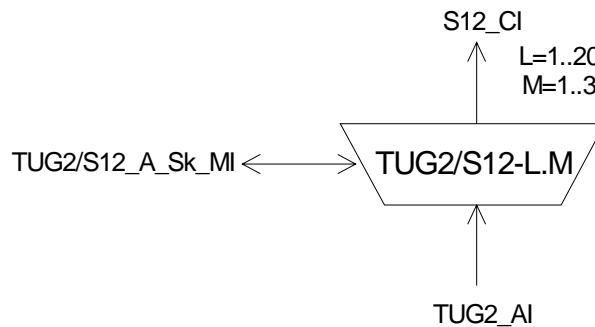
Processes:

This function recovers VC-12 data with frame phase information from a TU-12.

V1, V2 - TU-12 pointer interpretation: The function shall perform TU-12 pointer interpretation as specified in annex B in EN 300 417-1-1 [9] to recover the VC-12 frame phase within a TU-12 of a P4s.

TU-12 timeslot: The adaptation source function has access to a specific TU-12 of the TUG2 access point. The TU-12 is defined by the parameters L and M (L=1 to 20, M=1 to 3).

Figure 141 shows that more than one adaptation sink function exists in this TUG2 virtual sub-layer that can be connected to one TUG2 access point. In contradiction with the source direction, adaptation sink functions may be activated all together. This will presumably cause faults (e.g. cLOP) to be detected and reported. To prevent this an adaptation sink function can be deactivated.

Activation: The function shall perform the operation specified above when it is activated (MI_Active is true). Otherwise, it shall transmit the all-ONES signal at its output (CI_D) and not report its status via its management point.

Defects:

The function shall detect for dAIS and dLOP defect according the algorithm described under the pointer interpreter process in EN 300 417-1-1 [9], annex B, Pointer Interpretation.

Consequent actions:

- aAIS ← dAIS or dLOP or AI_TSF
- aSSF ← dAIS or dLOP or AI_TSF

On declaration of aAIS the function shall output all ONES signal within 1 ms; on clearing of aAIS the function shall output the recovered data within 1 ms.

Defect correlations:

- cAIS ← dAIS and (not AI_TSF) and AIS_Reported
- cLOP ← dLOP and (not AI_TSF)

It shall be an option to report AIS as a fault cause. This is controlled by means of the parameter AIS_Reported. The default shall be AIS_Reported = false.

Performance monitoring: none.

9.3.4.5 TUG2 to VC-11 layer adaptation sink function TUG2/S11*_A_Sk/L.M

Symbol:

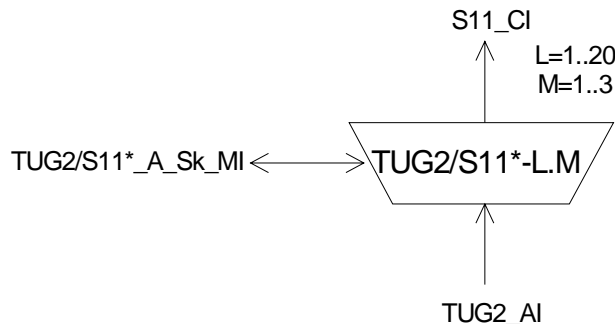

Figure 146: TUG2/S11*_A_Sk symbol

Interfaces:

Table 103: TUG2/S11*_A_Sk input and output signals

Input(s)	Output(s)
TUG2_AI_D	S11_CI_D
TUG2_AI_CK	S11_CI_CK
TUG2_AI_FS	S11_CI_FS
TUG2_AI_TSF	S11_CI_SSF
TUG2/S11*_A_Sk_MI_AIS_Reported	TUG2/S11*_A_Sk_MI_cLOP
TUG2/S11*_A_Sk_MI_Active	TUG2/S11*_A_Sk_MI_cAIS
NOTE: The TUG2/S11*_A_Sk functions can only be used in a P4s/SX-TUG2_A_Sk compound function. It can not be used as a stand alone function.	

Processes:

This function recovers VC-11 data with frame phase information from a TU-12:

V1, V2 - TU-12 pointer interpretation: The function shall perform TU-12 pointer interpretation as specified in annex B in EN 300 417-1-1 [9] to recover the VC-11 frame phase within a TU-12 of a P4s.

TU-12 timeslot: The adaptation source function has access to a specific TU-12 of the TUG2 access point. The TU-12 is defined by the parameters L and M (L=1 to 20, M=1 to 3).

Figure 141 shows that more than one adaptation sink function exists in this TUG2 virtual sub-layer that can be connected to one TUG2 access point. In contradiction with the source direction, adaptation sink functions may be activated all together. This will presumably cause faults (e.g. cLOP) to be detected and reported. To prevent this an adaptation sink function can be deactivated.

Activation: The function shall perform the operation specified above when it is activated (MI_Active is true). Otherwise, it shall transmit the all-ONEs signal at its output (CI_D) and not report its status via its management point.

Defects:

The function shall detect for dAIS and dLOP defect according the algorithm described under the pointer interpreter process in EN 300 417-1-1 [9], annex B, Pointer Interpretation.

Consequent actions:

- aAIS ← dAIS or dLOP or AI_TSF
- aSSF ← dAIS or dLOP or AI_TSF

On declaration of aAIS the function shall output all ONEs signal within 1 ms; on clearing of aAIS the function shall output the recovered data within 1 ms.

Defect correlations:

- cAIS ← dAIS and (not AI_TSF) and AIS_Reported
- cLOP ← dLOP and (not AI_TSF)

It shall be an option to report AIS as a fault cause. This is controlled by means of the parameter AIS_Reported. The default shall be AIS_Reported = false.

Performance monitoring: none.

9.3.5 P4s layer to P0s layer adaptation source P4s/P0s_A_So

Symbol:

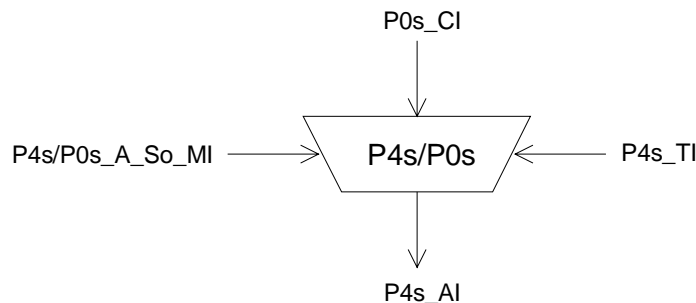

Figure 147: P4s/P0s_A_So symbol

Interfaces:**Table 104: P4s/P0s_A_So input and output signals**

Input(s)	Output(s)
P0s_CI_D P0s_CI_CK P0s_CI_FS P4s_TI_CK P4s_TI_FS P4s/P0s_A_So_MI_Active	P4s_AI_D

Processes:

This function provides the multiplexing of a 64 kbit/s information stream into the P4s_AI using slip buffering. It takes P0s_CI, defined in ETS 300 166 [14] as an octet structured bit-stream with a synchronous bit rate of 64 kbit/s, present at its input and inserts it into the P4s POH byte GC as defined in ETS 300 337 [10] and depicted in figure 104.

NOTE: Any frequency deviation between the 64 kbit/s signal and the P4s signal leads to octet slips.

Frequency justification and bitrate adaptation: The function shall provide for an elastic store (slip buffer) process. The data signal shall be written into the buffer under control of the associated input clock. The data shall be read out of the buffer under control of the P4s clock, frame position (P4s_TI), and justification decisions.

Each justification decision results in a corresponding negative/positive justification (slip) action. Upon a positive justification (slip) action, the reading of one 64 kbit/s octet (8 bits) shall be cancelled once. Upon a negative justification (slip) action, the same 64 kbit/s octet (8 bits) shall be read out a second time.

Buffer size: The elastic store (slip buffer) shall accommodate at least 18 μ s of wander without introducing errors.

Activation: The function shall access the access point when it is activated (MI_Active is true). Otherwise, it shall not access the access point.

Defects: none.

Consequent actions: none.

Defect correlations: none.

Performance monitoring: none.

9.3.6 P4s layer to P0s layer adaptation sink P4s/P0s_A_Sk

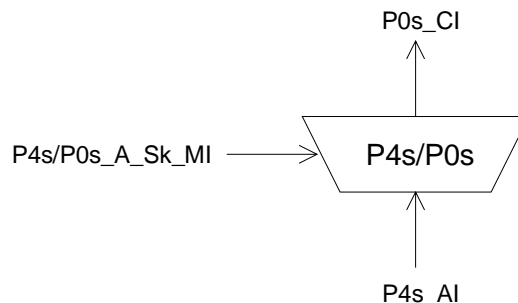
Symbol:**Figure 148: P4s/P0s_A_Sk symbol**

Interfaces:

Table 105: P4s/P0s_A_Sk input and output signals

Input(s)	Output(s)
P4s_AI_D	P0s_CI_D
P4s_AI_CK	P0s_CI_CK
P4s_AI_FS	P0s_CI_FS
P4s_AI_TSF	
P4s/P0s_A_Sk_MI_Active	

Processes:

The function extracts the general communications channel byte GC from the P4s layer Characteristic Information. The recovered byte provides a 64 kbit/s channel for the client (user).

Data latching and smoothing process: The function shall provide a data latching and smoothing function. Each 8-bit octet received shall be written and latched into a data store under the control of the P4s signal clock. The eight data bits shall then be read out of the store using a nominal 64 kHz clock which may be derived directly from the incoming E4 signal clock. (e.g. 139 264 kHz divided by a factor of 2176).

Activation: The function shall perform the operation specified above when it is activated (MI_Active is true). Otherwise, it shall transmit the all-ONEs signal at its output (CI_D).

Defects: none.

Consequent actions:

$$aAIS \leftarrow AI_TSF$$

On declaration of aAIS the function shall output an all-ONEs (AIS) signal - complying to the frequency limits for this signal (a bit rate in range 64 kbit/s ± 100 ppm) - within 1 ms; on clearing of aAIS the function shall output normal data within 1 ms.

Defect correlations: none.

Performance monitoring: none.

9.3.7 P4s to V0x adaptation source P4s/V0x_A_So

Symbol:

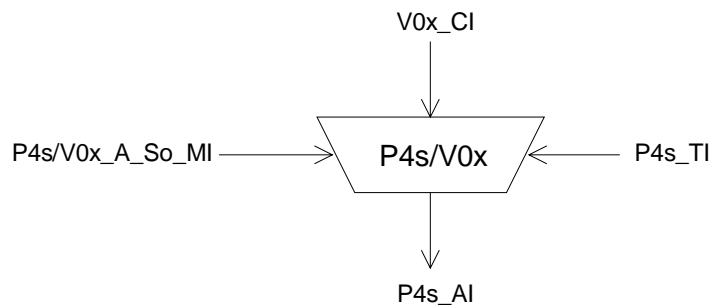

Figure 149: P4s/V0x_A_So symbol

Interfaces:**Table 106: P4s/V0x_A_So input and output signals**

Input(s)	Output(s)
V0x_CI_D P4s_TI_CK P4s_TI_FS P4s/V0x_A_So_MI_Active	P4s_AI_D V0x_CI_CK

Processes:

This function multiplexes the V0x_CI data (64 kbit/s) into the byte location GC as defined in ETS 300 337 [10] and depicted in figure 104.

Activation: The function shall access the access point when it is activated (MI_Active is true). Otherwise, it shall not access the access point.

Defects: none.

Consequent actions: none.

Defect correlations: none.

Performance monitoring: none.

9.3.8 P4s to V0x adaptation sink P4s/V0x_A_Sk

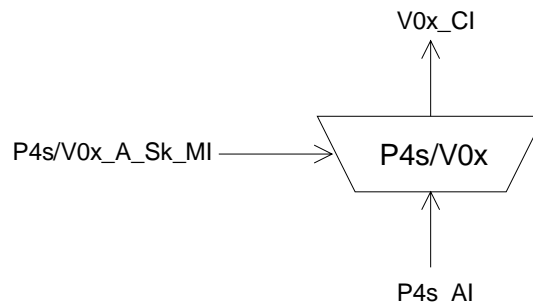
Symbol:**Figure 150: P4s/V0x_A_Sk symbol****Interfaces:****Table 107: P4s/V0x_A_Sk input and output signals**

Input(s)	Output(s)
P4s_AI_D P4s_AI_CK P4s_AI_FS P4s_AI_TSF P4s/V0x_A_Sk_MI_Active	V0x_CI_D V0x_CI_CK V0x_CI_SSF

Processes:

This function separates user channel data from P4s Overhead (byte GC) as defined in ETS 300 337 [10] and depicted in figure 104.

Activation: The function shall perform the operation specified above when it is activated (MI_Active is true). Otherwise, it shall transmit the all-ONES signal at its output (CI_D).

Defects: none.

Consequent actions:

aAIS ← AI_TSF

aSSF ← AI_TSF

On declaration of aAIS the function shall output an all-ONEs (AIS) signal - complying to the frequency limits for this signal (a bit rate in range 64 kbit/s \pm X ppm) - within 1 ms; on clearing of aAIS the function shall output normal data within 1 ms. X is for further study.

Defect correlations: none.

Performance monitoring: none.

9.3.9 P4s to DCC adaptation source P4s/DCC_A_So

Symbol:

Figure 151: P4s/DCC_A_So symbol

Interfaces:

Table 108: P4s/DCC_A_Sk input and output signals

Input(s)	Output(s)
DCC_CI_D P4s_TI_CK P4s_TI_FS P4s/DCC_A_So_MI_Active	P4s_AI_D DCC_CI_CK

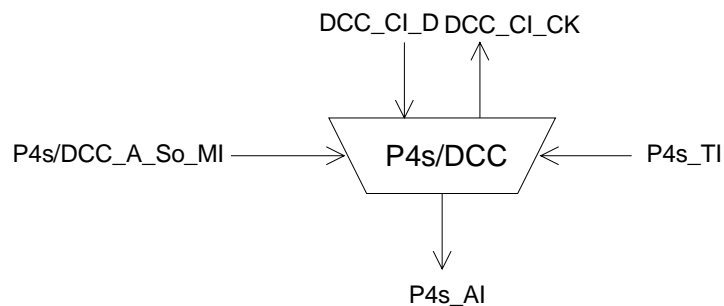
Processes:

The function multiplexes the DCC CI data (64 kbit/s) into the byte location GC as defined in ETS 300 337 [10] and depicted in figure 104 (see note).

NOTE: DCC transmission can be "disabled" when the matrix connection in the connected DCC_C function is removed.

Activation: The function shall access the access point when it is activated (MI_Active is true). Otherwise, it shall not access the access point.

Defects: none.

Consequent actions: none.

Defect correlations: none.

Performance monitoring: none.

9.3.10 P4s to DCC adaptation sink P4s/DCC_A_Sk

Symbol:

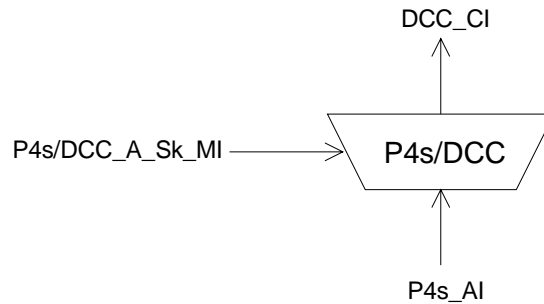

Figure 152: P4s/DCC_A_Sk symbol

Interfaces:

Table 109: P4s/DCC_A_Sk input and output signals

Input(s)	Output(s)
P4s_AI_D	DCC_CI_D
P4s_AI_CK	DCC_CI_CK
P4s_AI_FS	DCC_CI_SSF
P4s_AI_TSF	
P4s/DCC_A_Sk_MI_Active	

Processes:

The function separates DCC data from P4s Overhead (GC byte) as defined in ETS 300 337 [10] and depicted in figure 104 (see note).

NOTE: DCC processing can be "disabled" when the matrix connection in the connected DCC_C function is removed.

Activation: The function shall perform the operation specified above when it is activated (MI_Active is true). Otherwise, it shall transmit the all-ONES signal at its output (CI_D).

Defects: none.

Consequent actions:

aSSF ← AI_TSF

Defect correlations: none.

Performance monitoring: none.

9.3.11 P4s to SD adaptation source P4s/SD_A_So

Refer to EN 300 417-6-1 [12].

9.3.12 P4s to SD adaptation sink P4s/SD_A_Sk

Refer to EN 300 417-6-1 [12].

9.3.13 P4s to ATM VP compound adaptation source P4s/Avp_A_So

Refer to EN 301 163 [13].

9.3.14 P4s to ATM VP compound adaptation sink P4s/Avp_A_Sk

Refer to EN 301 163 [13].

9.3.15 P4s Layer Clock adaptation source P4s-LC_A_So

Refer to EN 300 417-6-1 [12].

9.4 P4s layer monitoring functions

9.4.1 P4s non-intrusive monitoring function P4sm_TT_Sk

Symbol:

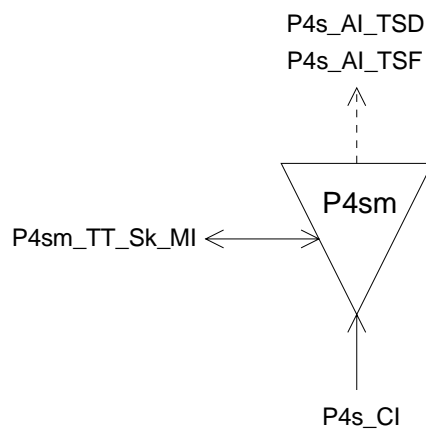

Figure 153: P4sm_TT_Sk symbol

Interfaces:**Table 110: P4sm_TT_Sk input and output signal**

Input(s)	Output(s)
P4sm_CI_D	P4sm_AI_TSF
P4sm_CI_CK	P4sm_AI_TSD
P4sm_CI_FS	P4sm_TT_Sk_MI_cTIM
P4sm_CI_SSF	P4sm_TT_Sk_MI_cUNEQ
P4sm_TT_Sk_MI_TPmode	P4sm_TT_Sk_MI_cDEG
P4sm_TT_Sk_MI_SSF_Reported	P4sm_TT_Sk_MI_cRDI
P4sm_TT_Sk_MI_ExtI	P4sm_TT_Sk_MI_cSSF
P4sm_TT_Sk_MI_RDI_Reported	P4sm_TT_Sk_MI_ActI
P4sm_TT_Sk_MI_DEGTHR	P4sm_TT_Sk_MI_pN_EBC
P4sm_TT_Sk_MI_DEGM	P4sm_TT_Sk_MI_pF_EBC
P4sm_TT_Sk_MI_1second	P4sm_TT_Sk_MI_pN_DS
P4sm_TT_Sk_MI_TIMdis	P4sm_TT_Sk_MI_pF_DS

NOTE 1: This non-intrusive monitor trail termination sink function has no associated source function.

Processes:

This function monitors for 140 Mbit/s frame errors and recovers the trail termination status as defined in ETS 300 337 [10]. It extracts the payload independent overhead bytes EM, TR, MA bits 1, 2 from the P4sm layer Characteristic information:

EM: Even bit parity (BIP-8) shall be computed for each bit n of every byte of the preceding frame and compared with bit n of EM recovered from the current frame (n=1 to 8 inclusive). A difference between the computed and recovered EM values shall be taken as evidence of one or more errors (nN_B) in the computation block.

TR: The 16 byte Trail Trace Identifier (TTI) shall be recovered from the TR byte and shall be made available for network management purposes. The application and the acceptance and mismatch detection process shall be performed as described in the EN 300 417-1-1 [9], clauses 7.1 and 8.2.1.3.

The trace identifier process in this function is required to support "mode 1" (EN 300 417-1-1 [9], clause 7.1) only. "Transmission and Multiplexing (TM); Generic requirements of transport functionality of equipment; Part 1-1: Generic processes and performance" P4s connection equipment does not exist.

MA[1-2]: The relevant information carried in the MA byte (RDI in bit 1, REI in bit 2) shall be extracted to enable single ended maintenance of a bi-directional Trail. The REI (nF_B) shall be used to monitor the error performance of the reverse direction of transmission; the RDI provides information as to the status of the remote receiver. A "1" indicates a RDI state, while a "0" indicates the normal working state. The application process shall be performed as specified in EN 300 417-1-1 [9], clauses 7.4.2 (REI), 7.4.11 and 8.2 (RDI).

MA[3-5]: The information in the signal label bits shall be extracted to allow unequipped P4s and P4s-AIS defect detection.

Defects:

The detection and removal conditions and processes for dUNEQ, dDEG, dRDI and dTIM are described in EN 300 417-1-1 [9], clause 8.2.1 with the condition "aSSF" read as "aSSF or P4s dAIS". To use the function within e.g. a tandem connection (see note 2), it shall be possible to disable the trace id mismatch detection (TIMdis).

NOTE 2: Presumably, in such case the Trace Id. will be unknown to the tandem connection operator.

P4s AIS:

The function shall detect for an AIS condition by monitoring the P4s PSL for code "111". If 5 consecutive frames contain the "111" pattern in bits 3 to 5 of the MA byte a dAIS defect shall be detected. dAIS shall be cleared if in 5 consecutive frames any pattern other than the "111" is detected in bits 3 to 5 of the MA byte.

Consequent actions:

aTSF ← CI_SSF or dAIS or dUNEQ or dTIM
aTSD ← dDEG

Defect correlations:

cUNEQ	←	MON and dUNEQ
cTIM	←	MON and dTIM (and not dUNEQ)
cDEG	←	MON and dDEG and (not dUNEQ) and (not dTIM)
cRDI	←	MON and dRDI and (not dTIM) and (not dUNEQ) and RDI_Reported
cSSF	←	MON and (CI_SSF or dAIS) and SSF_Reported

It shall be an option to report SSF as a fault cause. This is controlled by means of the parameter SSF_Reported. The default shall be SSF_Reported = false.

It shall be an option to report RDI as a fault cause. This is controlled by means of the parameter RDI_Reported. The default shall be RDI_Reported = false.

Performance monitoring:

The performance monitoring process shall be performed as specified in EN 300 417-1-1 [9], clauses 8.2.4 to 8.2.7.

pN_DS	←	aTSF or dEQ
pF_DS	←	dRDI
pN_EBC	←	ΣnN_B
pF_EBC	←	ΣnF_B

NOTE 3: pF_DS/pF_EBC represent the performance of the total trail while pN_DS/pN_EBC represents only part of the trail up to the point of the non-intrusive monitor.

9.5 P4s layer trail protection functions

For further study.

9.6 P4s tandem connection sublayer functions

9.6.1 P4s tandem connection trail termination source function (P4sD_TT_So)

Symbol:

Figure 154: P4sD_TT_So symbol

Interfaces:**Table 111: P4sD_TT_So input and output signals**

Input(s)	Output(s)
P4sD_AI_D	P4s_CI_D
P4sD_AI_CK	P4s_CI_CK
P4sD_AI_FS	P4s_CI_FS
P4sD_AI_SF	
P4sD_RI_RDI	
P4sD_RI_REI	
P4sD_RI_ODI	
P4sD_RI_OEI	
P4sD_TT_So_MI_TxTI	

Processes:

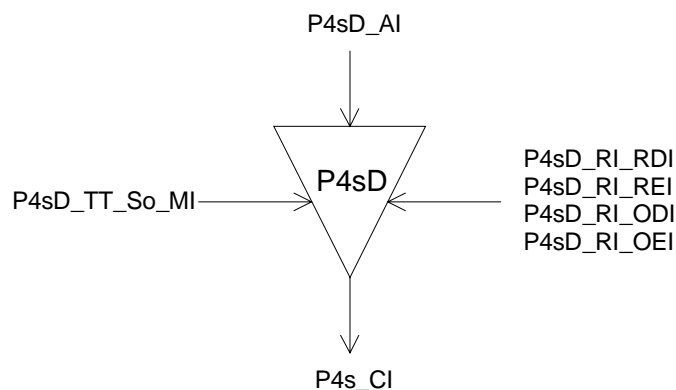
NR[8][73]: The function shall insert the TC RDI code within 20 ms after the RDI request generation (RI_RDI) in the tandem connection trail termination sink function. It ceases TC RDI code insertion within 20 ms after the TC RDI request has cleared.

NOTE 1: NR[x][y] refers to bit x (x = 7,8) of byte NR in frame y (y=1 to 76) of the 76 frame multiframe.

NR[5]: The function shall insert the RI_REI value in the REI bit within 20 ms.

NR[7][74]: The function shall insert the ODI code within 20 ms after the ODI request generation (aODI) in the tandem connection trail termination sink function. It ceases ODI code insertion within 20 ms after the ODI request has cleared.

NR[6]: The function shall insert the RI_OEI value in the OEI bit within 20 ms.

NR[7-8]: The function shall insert in the multiframed NR[7-8] channel:

- the Frame Alignment Signal (FAS) "1111 1111 1111 1110" in FAS bits in frames 1 to 8;
- the TC trace identifier, received via MI_TxTI, in the TC-TI bits in frames 9 to 72;
- the TC RDI (NR[8][73]) and ODI (NR[7][74]) signals; and
- "0" in the six reserved bits in frames 73 to 76.

NR[1-4]: Even BIP-8 shall be computed for each bit n of every byte of the preceding incoming P4s frame (P4s_AI) including EM byte and compared with byte EM recovered from the current frame. A difference between the computed and recovered BIP-8 values shall be taken as evidence of one or more errors in the computation block, and shall be inserted in bits 1 to 4 of byte NR (see figure 96, table 66). If AI_SF is true, code "1110" shall be inserted in bits 1 to 4 of byte NR instead of the number of incoming BIP-8 violations.

NOTE 2: Zero BIP-8 violations detected in the tandem connection incoming signal is coded with a non-all-ZEROS IEC code. This allows this IEC field to be used at the TC tail end as differentiator between TC incoming unequipped VC and unequipped TC.

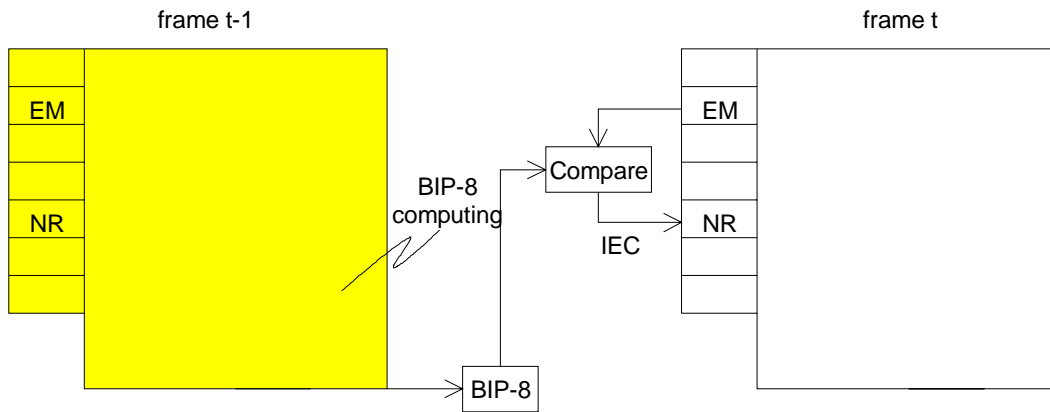

Figure 155: TC IEC computing and insertion

Table 112: IEC code generation

Number of BIP-8 violations	NR[1]	NR[2]	NR[3]	NR[4]
1	0	0	0	1
2	0	0	1	0
3	0	0	1	1
4	0	1	0	0
5	0	1	0	1
6	0	1	1	0
7	0	1	1	1
8	1	0	0	0
0	1	0	0	1

EM: The function shall compensate the P4s BIP8 (in EM) according the following rule:

Since the BIP-8 parity check is taken over the P4s (including NR), writing into NR at the P4sD_TT_So will affect the P4s path parity calculation. Unless this is compensated for, a device which monitors P4s path parity within the Tandem Connection (e.g., a non-intrusive monitor) may incorrectly count errors. The BIP-8 parity bits should always be consistent with the current state of the P4S. Therefore, whenever NR is written, BIP-8 shall be modified to compensate for the change in the NR value. Since the BIP-8 value in a given frame reflects a parity check over the previous frame (including the BIP-8 bits in that frame), the changes made to the BIP-8 bits in the previous frame shall also be considered in the compensation of BIP-8 for the current frame. Therefore, the following equation shall be used for BIP-8 compensation:

$$EM[i]'(t) = EM[i](t-1) \oplus EM[i]'(t-1) \oplus NR[i](t-1) \oplus NR[i]'(t-1) \oplus EM[i](t)$$

Where:

- EM[i] = the existing EM[i] value in the incoming signal;
- EM[i]' = the new (compensated) EM[i] value;
- NR[i] = the existing NR[i] value in the incoming signal;
- NR[i]' = the new value written into the NR[i] bit;
- \oplus = exclusive OR operator;
- t = the time of the current frame;
- t-1 = the time of the previous frame.

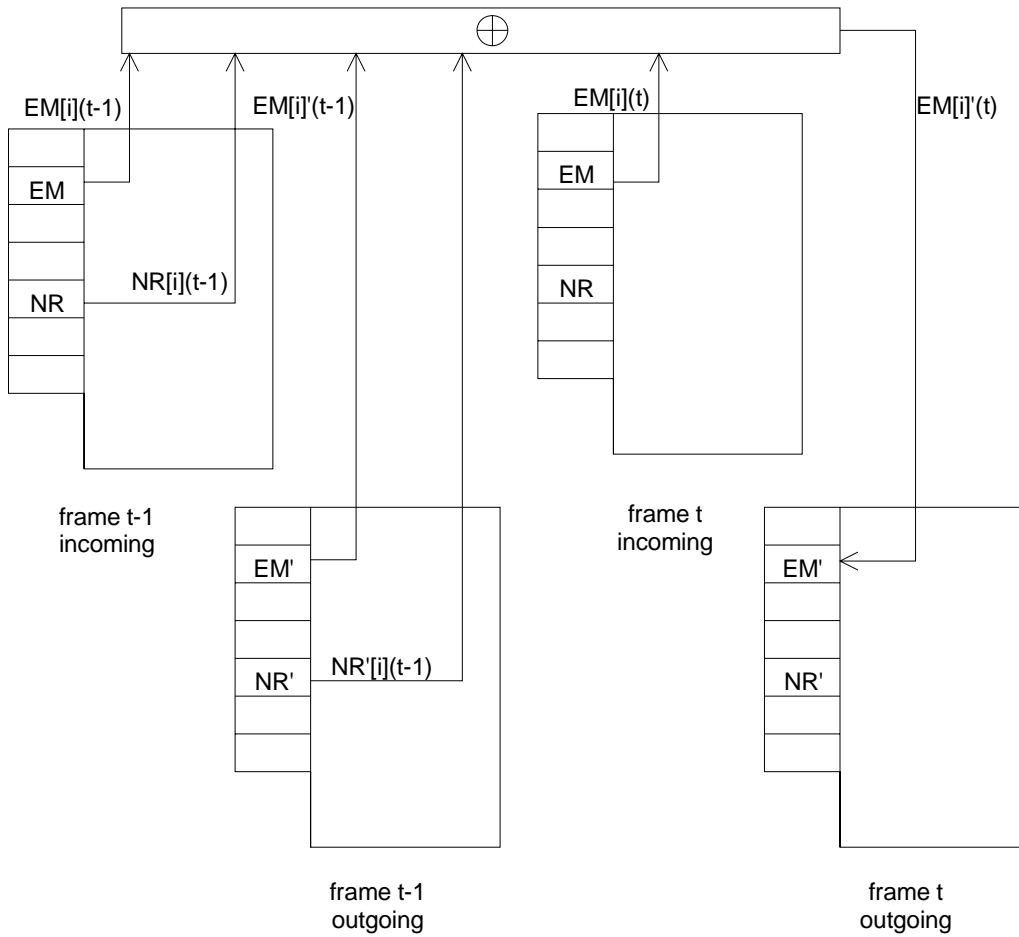

Figure 156: EM[i], i=1 to 8 compensating process

- Defects: none.
- Consequent actions: none.
- Defect correlations: none.
- Performance monitoring: none.

9.6.2 P4s tandem connection trail termination sink function (P4sD_TT_Sk)

Symbol:

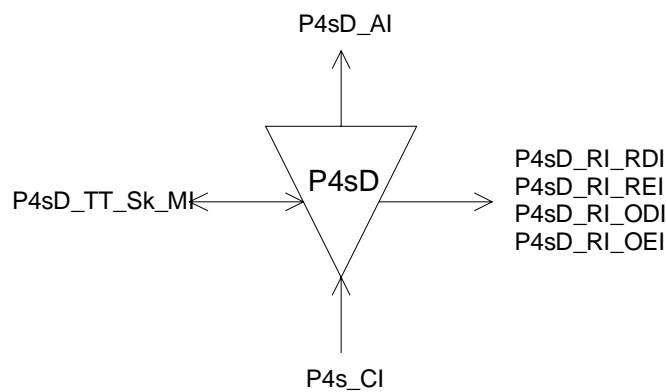

Figure 157: P4sD_TT_Sk symbol

Interfaces:**Table 113: P4sD_TT_Sk input and output signals**

Input(s)	Output(s)
P4s_CI_D	P4sD_AI_D
P4s_CI_CK	P4sD_AI_CK
P4s_CI_FS	P4sD_AI_FS
P4s_CI_SSF	P4sD_AI_TSF
P4sD_TT_Sk_MI_ExtI	P4sD_AI_TSD
P4sD_TT_Sk_MI_AIS_Reported	P4sD_AI_OSF
P4sD_TT_Sk_MI_SSF_Reported	P4sD_TT_Sk_MI_cLTC
P4sD_TT_Sk_MI_RDI_Reported	P4sD_TT_Sk_MI_cTIM
P4sD_TT_Sk_MI_ODI_Reported	P4sD_TT_Sk_MI_cUNEQ
P4sD_TT_Sk_MI_TIMdis	P4sD_TT_Sk_MI_cDEG
P4sD_TT_Sk_MI_DEGM	P4sD_TT_Sk_MI_cRDI
P4sD_TT_Sk_MI_DEGTHR	P4sD_TT_Sk_MI_cSSF
P4sD_TT_Sk_MI_1second	P4sD_TT_Sk_MI_cODI
P4sD_TT_Sk_MI_TPmode	P4sD_TT_Sk_MI_clncAIS
	P4sD_TT_Sk_MI_AcTI
	P4sD_RI_RDI
	P4sD_RI_REI
	P4sD_RI_ODI
	P4sD_RI_OEI
	P4sD_TT_Sk_MI_pN_EBC
	P4sD_TT_Sk_MI_pF_EBC
	P4sD_TT_Sk_MI_pN_DS
	P4sD_TT_Sk_MI_pF_DS
	P4sD_TT_Sk_MI_pON_EBC
	P4sD_TT_Sk_MI_pOF_EBC
	P4sD_TT_Sk_MI_pON_DS
	P4sD_TT_Sk_MI_pOF_DS

Processes:

TC EDC violations: Even bit parity shall be computed for each bit n of every byte of the preceding P4s and compared with bit n of EM recovered from the current frame ($n=1$ to 8 inclusive). A difference between the computed and recovered EM values shall be taken as evidence of one or more errors in the computation block (nON_B). The magnitude (absolute value) of the difference between this calculated number of errors and the number of errors written into the IEC (see table 68) at the trail termination source shall be used to determine the error performance of the tandem connection for each transmitted P4s (see figure 99). If this magnitude of the difference is one or more, an errored TC block is detected (nN_B). If one or more errors were detected in the computation block, an errored P4s block (nON_B) shall be declared.

NOTE 1: The EM data and the IEC read in the current frame both apply to the previous frame.

Table 114: IEC code interpretation

NR[1]	NR[2]	NR[3]	NR[4]	IEC code interpretation
0	0	0	0	0 errors
0	0	0	1	1 error
0	0	1	0	2 errors
0	0	1	1	3 errors
0	1	0	0	4 errors
0	1	0	1	5 errors
0	1	1	0	6 errors
0	1	1	1	7 errors
1	0	0	0	8 errors
1	0	0	1	0 errors
1	0	1	0	0 errors
1	0	1	1	0 errors
1	1	0	0	0 errors
1	1	0	1	0 errors
1	1	1	0	0 errors
1	1	1	1	0 errors

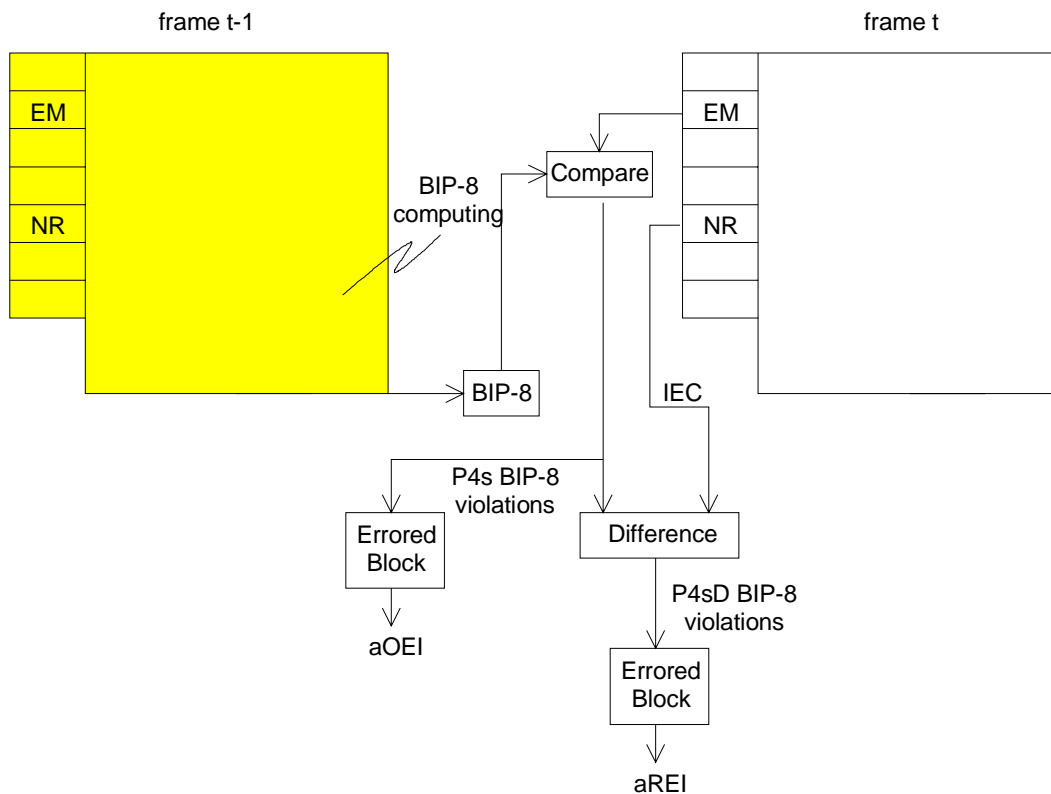

Figure 158: P4sD and P4s BIP-8 computing and comparison

NR[1-4]: The function shall extract the Incoming Error Code (IEC). It shall accept the received code without further processing.

NR[7-8][9-72]: The Received Trail Trace Identifier RxTI shall be recovered from the tandem connection trail trace identifier overhead and shall be made available as AcTI for network management purposes. The application and acceptance process shall be performed as specified in EN 300 417-1-1 [9], clauses 7.1 and 8.2.1.3. The mismatch detection process shall be as specified below.

The trace identifier process in this function is required to support "mode 1" (EN 300 417-1-1 [9], clause 7.1) operation only. "Old" tandem connection equipment does not exist.

NR[1-4]: The function shall extract the Incoming AIS code.

NR[5], NR[8][73]: The information carried in the REI, RDI bits in byte NR shall be extracted to enable single ended maintenance of a bi-directional tandem connection Trail. The REI (nF_B) shall be used to monitor the error performance of the other direction of transmission, and the RDI shall be used to provide information as to the status of the remote receiver. A "1" indicates a Remote Defect Indication state, while a "0" indicates the normal, working state. The application process shall be performed as specified in EN 300 417-1-1 [9], clauses 7.4.2 (REI), 7.4.11 and 8.2 (RDI).

NR[6], NR[7][74]: The information carried in the OEI, ODI bits in byte NR shall be extracted to enable single ended (intermediate) maintenance of a the P4s egressing the tandem connection Trail. The OEI (nOF_B) shall be used to monitor the error performance of the other direction of transmission, and the ODI shall be used to provide information as to the status of the remote receiver. A "1" indicates a Outgoing Defect Indication state, while a "0" indicates the normal, working state. The application process shall be performed equivalent to the remote maintenance case, as specified in EN 300 417-1-1 [9], clauses 7.4.2 (REI/OEI), 7.4.11 and 8.2 (RDI/ODI).

NR[7-8] - Multiframe alignment: The function shall perform a multiframe alignment on bits 7 and 8 of byte NR to recover the TTI, RDI, and ODI signals transported within the multiframe bits. The multiframe alignment shall be found by searching for the pattern "1111 1111 1111 1110" within the bits 7 and 8 of byte NR. The signal shall be continuously checked with the presumed multiframe start position for the alignment.

Frame alignment is deemed to have been lost (entering Out Of Multiframe (OOM) state) when two consecutive FAS are detected in error (i.e. ≥ 1 error in each FAS);

Frame alignment is deemed to have been recovered (entering In Multiframe (IM) state) when one non-errored FAS is found.

NR: The function shall terminate NR channel by inserting an all-ZEROs pattern.

EM: The function shall compensate the P4s BIP8 in byte EM according the algorithm defined in P4sD_TT_So.

Defects:

TC Unequipped (dUNEQ):

The function shall detect for an unequipped Tandem Connection (UNEQ) condition by monitoring byte NR for code "00000000". The unequipped defect (dUNEQ) shall be detected if five consecutive P4s frames contain the "0000 0000" pattern in byte NR. The dUNEQ defect shall be cleared if in five consecutive NR frames any pattern other than the "0000 0000" is detected in byte NR.

TC Loss of Tandem Connection (dLTC):

The function shall detect for the presence/absence of the tandem connection overhead in the byte NR by evaluating the multiframe alignment signal in bits 7 and 8 of byte NR. The loss of tandem connection defect (dLTC) shall be detected if the multiframe alignment process is in the OOM state. The dLTC shall be cleared if the multiframe alignment process is in the IM state.

TC Connectivity (Trace Identifier) (dTIM):

The function shall detect for a TC mis-connection condition by monitoring the TC trace identifier. The Trace Identifier Mismatch defect (dTIM) shall be detected and cleared within a maximum period of 1 s in the absence of bit errors.

The defect detection process and its operation during the presence of bit errors is for further study.

The defect shall be suppressed during the receipt of SSF.

It shall be possible to disable the trace identifier mismatch defect detection (TIMdis).

TC Signal Degrade (dDEG):

The function shall detect for a TC signal degrade defect condition by monitoring for TC BIP-8 violations. The algorithm shall be according clause 8.2.1.4 in EN 300 417-1-1 [9].

TC Remote Defect (dRDI):

The function shall detect for a TC remote defect indication defect condition by monitoring the TC RDI signal. The algorithm shall be according clause 8.2.1.5 in EN 300 417-1-1 [9].

TC Remote Outgoing P4S Defect (dODI):

The function shall detect for a TC remote outgoing P4S defect indication defect condition by monitoring the TC ODI signal. The algorithm shall be according clause 8.2.1.5 in EN 300 417-1-1 [9].

Incoming AIS (dIncAIS):

The function shall detect for a tandem connection incoming AIS condition by monitoring the IEC bits in byte NR for code "1110". If 5 consecutive frames contain the "1110" pattern in the IEC bits a dIncAIS defect shall be detected. dIncAIS shall be cleared if in 5 consecutive frames any pattern other than the "1110" is detected in the IEC bits.

NOTE 2: Bits 1 to 4 of byte NR support two applications: conveying the incoming error information (table 68) and conveying the incoming AIS information to the TC tail end. Codes 0000 to 1101, 1111 represent IncAIS is false, code 1110 represents IncAIS is true.

Consequent actions:

The function shall perform the following consequent actions (refer to clause 8.2.2 in EN 300 417-1-1 [9]):

aAIS	←	dUNEQ or dTIM or dLTC
aTSF	←	CI_SSF or dUNEQ or dTIM or dLTC
aTSD	←	dDEG
aRDI	←	CI_SSF or dUNEQ or dTIM or dLTC
aREI	←	nN_B
aODI	←	CI_SSF or dUNEQ or dTIM or dIncAIS or dLTC
aOEI	←	nON_B
aOSF	←	CI_SSF or dUNEQ or dTIM or dLTC or dIncAIS

The function shall insert the all-ONEs (AIS) signal within 250 µs after AIS request generation (aAIS), and cease the insertion within 250 µs after the AIS request has cleared.

Defect correlations:

The function shall perform the following defect correlations (refer to clause 8.2.3 in EN 300 417-1-1 [9]):

cUNEQ	←	MON and dUNEQ
cLTC	←	MON and (not dUNEQ) and dLTC
cTIM	←	MON and (not dUNEQ) and (not dLTC) and dTIM
cDEG	←	MON and (not dTIM) and (not dLTC) and dDEG
cSSF	←	MON and CI_SSF and SSF_reported
cRDI	←	MON and (not dUNEQ) and (not dTIM) and (not dLTC) and dRDI and RDI_Reported
cODI	←	MON and (not dUNEQ) and (not dTIM) and (not dLTC) and dODI and ODI_Reported
cIncAIS	←	MON and dIncAIS and (not CI_SSF) and (not dLTC) and (not dTIM) and AIS_reported

It shall be an option to report SSF as a fault cause. This is controlled by means of the parameter SSF_Reported. The default shall be SSF_Reported = false.

It shall be an option to report RDI as a fault cause. This is controlled by means of the parameter RDI_Reported. The default shall be RDI_Reported = false.

It shall be an option to report ODI as a fault cause. This is controlled by means of the parameter ODI_Reported. The default shall be ODI_Reported = false.

Performance monitoring:

The following TC error performance parameters shall be counted for each 1-second period (refer to clauses 8.2.4 to 8.2.7 in EN 300 417-1-1 [9]):

pN_DS	←	aTSF or dEQ
pF_DS	←	dRDI
pN_EBC	←	ΣnN_B
pF_EBC	←	ΣnF_B
pON_DS	←	aODI or dEQ
pOF_DS	←	dODI
pON_EBC	←	ΣnON_B
pOF_EBC	←	ΣnOF_B

pN_EBC and pN_DS do not represent the actual performance monitoring support within an equipment. For that, these pN_DS/pN_EBC signals shall be connected to performance monitoring functions within the element management function. Similar for the far-end signals pF_EBC and pF_DS and for pON_EBC/pON_DS, pOF_EBC/pOF_DS.

9.6.3 P4s tandem connection to p4s adaptation source function (P4sD/P4s_A_So)

Symbol:

Figure 159: P4sD/P4s_A_So symbol

Interfaces:

Table 115: P4sD/P4s_A_So input and output signals

Input(s)	Output(s)
P4s_CI_D	P4sD_AI_D
P4s_CI_CK	P4sD_AI_CK
P4s_CI_FS	P4sD_AI_FS
P4s_CI_SSF	P4sD_AI_SF
P4s_TI_CK	

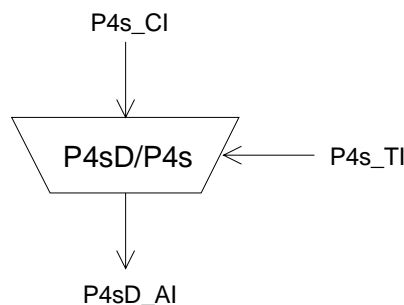
Processes:

NOTE 1: The function has no means to verify the existence of a tandem connection within the incoming signal. Nested tandem connections are not supported.

The function shall replace the incoming P4s signal (P4s_CI) by a local generated P4s frame with valid FA1 and FA2 bytes and all ONEs for all other bytes (i.e. enter "holdover") if an all-ONES (AIS) P4S is received (i.e. if CI_SSF is TRUE).

NOTE 2: The local frame start is generated with the P4s_TI timing.

Defects: none.

Consequent actions:

AI_SF ← CI_SSF

Defect correlations: none.

Performance monitoring: none.

9.6.4 P4s tandem connection to p4s adaptation sink function (P4sD/P4s_A_Sk)

Symbol:

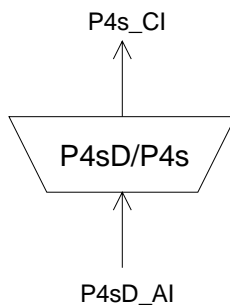

Figure 160: P4sD/P4s_A_Sk symbol

Interfaces:

Table 116: P4sD/P4s_A_Sk input and output signals

Input(s)	Output(s)
P4sD_AI_D	P4s_CI_D
P4sD_AI_CK	P4s_CI_CK
P4sD_AI_FS	P4s_CI_FS
P4sD_AI_OSF	P4s_CI_SSF

Processes:

The function shall restore the invalid frame start condition (i.e. output aSSF = true) if that existed at the ingress of the tandem connection.

NOTE: In addition, the invalid frame start condition is activated on a tandem connection connectivity defect condition that causes all-ONEs (AIS) insertion in the P4sD_TT_Sk.

Defects: none.

Consequent actions:

aAIS ← AI_OSF

aSSF ← AI_OSF

The function shall insert the all-ONEs (AIS) signal within 250 μs after AIS request generation (aAIS), and cease the insertion within 250 μs after the AIS request has cleared.

Defect correlations: none.

Performance monitoring: none.

9.6.5 P4s tandem connection non-intrusive trail termination sink function (P4sDm_TT_Sk)

Symbol:

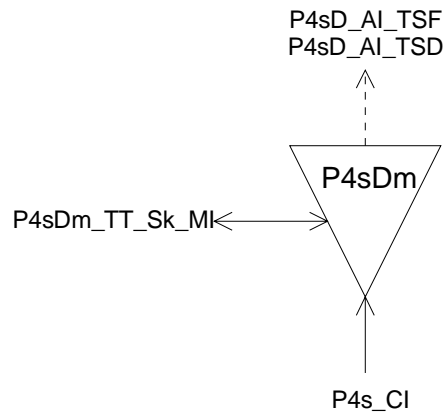

Figure 161: P4sDm_TT_Sk symbol

Interfaces:

Table 117: P4sDm_TT_Sk input and output signals

Input(s)	Output(s)
P4s_CI_D	P4sD_AI_TSF
P4s_CI_CK	P4sD_AI_TSD
P4s_CI_FS	P4sDm_TT_Sk_MI_cLTC
P4s_CI_SSF	P4sDm_TT_Sk_MI_cTIM
P4sDm_TT_Sk_MI_ExTI	P4sDm_TT_Sk_MI_cUNEQ
P4sDm_TT_Sk_MI_SSF_Reported	P4sDm_TT_Sk_MI_cDEG
P4sDm_TT_Sk_MI_RDI_Reported	P4sDm_TT_Sk_MI_cRDI
P4sDm_TT_Sk_MI_ODI_Reported	P4sDm_TT_Sk_MI_cSSF
P4sDm_TT_Sk_MI_TIMdis	P4sDm_TT_Sk_MI_cODI
P4sDm_TT_Sk_MI_DEGM	P4sDm_TT_Sk_MI_AcTI
P4sDm_TT_Sk_MI_DEGTHR	P4sDm_TT_Sk_MI_pN_EBC
P4sDm_TT_Sk_MI_1second	P4sDm_TT_Sk_MI_pF_EBC
P4sDm_TT_Sk_MI_TPmode	P4sDm_TT_Sk_MI_pN_DS
	P4sDm_TT_Sk_MI_pF_DS
	P4sDm_TT_Sk_MI_pOF_EBC
	P4sDm_TT_Sk_MI_pOF_DS

Processes:

This function can be used to perform the following:

- 1) single ended maintenance of the TC by monitoring at an intermediate node, using remote information (RDI, REI);
- 2) aid in fault localization within TC trail by monitoring near-end defects;
- 3) monitoring of P4S performance at TC egressing point (except for connectivity defects before the TC) using remote outgoing information (ODI,OEI).

TC EDC violations: Even bit parity shall be computed for each bit n of every byte of the preceding P4s and compared with bit n of EM recovered from the current frame ($n=1$ to 8 inclusive). A difference between the computed and recovered EM values shall be taken as evidence of one or more errors in the computation block (nON_B). The magnitude (absolute value) of the difference between this calculated number of errors and the number of errors written into the IEC (see table 68) at the trail termination source shall be used to determine the error performance of the tandem connection for each transmitted P4s (see figure 99). If this magnitude of the difference is one or more, an errored TC block is detected (nN_B). Refer to P4sD_TT_Sk. If one or more errors were detected in the computation block, an errored P4s block (nON_B) shall be declared.

NR[1-4]: The function shall extract the Incoming Error Code (IEC). It shall accept the received code without further processing.

NR[7-8][9-72]: The Received Trail Trace Identifier RxTI shall be recovered from the tandem connection trail trace identifier overhead and shall be made available as AcTI for network management purposes. The application and acceptance process shall be performed as specified in EN 300 417-1-1 [9], clauses 7.1 and 8.2.1.3. The mismatch detection process shall be as specified below.

The trace identifier process in this function is required to support "mode 1" (EN 300 417-1-1 [9], clause 7.1) operation only. "Old" tandem connection equipment does not exist.

NR[1-4]: The function shall extract the Incoming AIS code.

NR[5], NR[8][73]: The information carried in the REI, RDI bits in byte NR shall be extracted to enable single ended maintenance of a bi-directional tandem connection Trail. The REI (nF_B) shall be used to monitor the error performance of the other direction of transmission, and the RDI shall be used to provide information as to the status of the remote receiver. A "1" indicates a Remote Defect Indication state, while a "0" indicates the normal, working state. The application process shall be performed as specified in EN 300 417-1-1 [9], clauses 7.4.2 (REI), 7.4.11 and 8.2 (RDI).

NR[6], NR[7][74]: The information carried in the OEI, ODI bits in byte NR shall be extracted to enable single ended (intermediate) maintenance of a the P4s egressing the tandem connection Trail. The OEI (nOF_B) shall be used to monitor the error performance of the other direction of transmission, and the ODI shall be used to provide information as to the status of the remote receiver. A "1" indicates a Outgoing Defect Indication state, while a "0" indicates the normal, working state. The application process shall be performed equivalent to the remote maintenance case, as specified in EN 300 417-1-1 [9], clauses 7.4.2 (REI/OEI), 7.4.11 and 8.2 (RDI/ODI).

NR[7-8] - Multiframe alignment: The function shall perform a multiframe alignment on bits 7 and 8 of byte NR to recover the TTI, RDI, and ODI signals transported within the multiframe bits. The multiframe alignment shall be found by searching for the pattern "1111 1111 1111 1110" within the bits 7 and 8 of byte NR. The signal shall be continuously checked with the presumed multiframe start position for the alignment.

Frame alignment is deemed to have been lost (entering Out Of Multiframe (OOM) state) when two consecutive FAS are detected in error (i.e. ≥ 1 error in each FAS);

Frame alignment is deemed to have been recovered (entering In Multiframe (IM) state) when one non-errored FAS is found.

Defects:

TC Unequipped (dUNEQ):

The function shall detect for an unequipped Tandem Connection (UNEQ) condition by monitoring byte NR for code "00000000". The unequipped defect (dUNEQ) shall be detected if five consecutive P4s frames contain the "0000 0000" pattern in byte NR. The dUNEQ defect shall be cleared if in five consecutive NR frames any pattern other than the "0000 0000" is detected in byte NR.

TC Loss of Tandem Connection (dLTC):

The function shall detect for the presence/absence of the tandem connection overhead in the byte NR by evaluating the multiframe alignment signal in bits 7 and 8 of byte NR. The loss of tandem connection defect (dLTC) shall be detected if the multiframe alignment process is in the OOM state. The dLTC shall be cleared if the multiframe alignment process is in the IM state.

TC Connectivity (Trace Identifier) (dTIM):

The function shall detect for a TC mis-connection condition by monitoring the TC trace identifier. The Trace Identifier Mismatch defect (dTIM) shall be detected and cleared within a maximum period of 1 s in the absence of bit errors.

The defect detection process and its operation during the presence of bit errors is for further study.

The defect shall be suppressed during the receipt of SSF.

It shall be possible to disable the trace identifier mismatch defect detection (TIMdis).

TC Signal Degrade (dDEG):

The function shall detect for a TC signal degrade defect condition by monitoring for TC BIP-8 violations. The algorithm shall be according clause 8.2.1.4 in EN 300 417-1-1 [9].

TC Remote Defect (dRDI):

The function shall detect for a TC remote defect indication defect condition by monitoring the TC RDI signal. The algorithm shall be according clause 8.2.1.5 in EN 300 417-1-1 [9].

TC Remote Outgoing P4S Defect (dODI):

The function shall detect for a TC remote outgoing P4S defect indication defect condition by monitoring the TC ODI signal. The algorithm shall be according clause 8.2.1.5 in EN 300 417-1-1 [9].

Consequent actions:

aTSF ← CI_SSF or dUNEQ or dTIM or dLTC
 aTSD ← dDEG

Defect correlations:

The function shall perform the following defect correlations (refer to clause 8.2.3 in EN 300 417-1-1 [9]):

cUNEQ ← MON and dUNEQ
 cLTC ← MON and (not dUNEQ) and dLTC
 cTIM ← MON and (not dUNEQ) and (not dLTC) and dTIM
 cDEG ← MON and (not dTIM) and (not dLTC) and dDEG
 cSSF ← MON and CI_SSF and SSF_reported
 cRDI ← MON and (not dUNEQ) and (not dTIM) and (not dLTC) and dRDI and RDI_reported
 cODI ← MON and (not dUNEQ) and (not dTIM) and (not dLTC) and dODI and ODI_Reported

It shall be an option to report SSF as a fault cause. This is controlled by means of the parameter SSF_Reported. The default shall be SSF_Reported = false.

It shall be an option to report RDI as a fault cause. This is controlled by means of the parameter RDI_Reported. The default shall be RDI_Reported = false.

It shall be an option to report ODI as a fault cause. This is controlled by means of the parameter ODI_Reported. The default shall be ODI_Reported = false.

Performance monitoring:

The following TC error performance parameters shall be counted for each 1-second period (refer to clauses 8.2.4 to 8.2.7 in EN 300 417-1-1 [9]):

pN_DS ← aTSF or dEQ
 pF_DS ← dRDI
 pN_EBC ← ΣnN_B
 pF_EBC ← ΣnF_B
 pOF_DS ← dODI
 pOF_EBC ← ΣnOF_B

10 P4x path layer functions

P4x layer CP

The Characteristic Information CI at this point is a 139 264 kbit/s bit stream of any content; e.g. P4s, P4e, or without standardized frame.

There are currently no P4x atomic functions defined. P4x_CP is defined only, supporting fixed interconnections.

11 P32x path layer functions

P32x layer CP

The Characteristic Information CI at this point is a 44 736 kbit/s bit stream of any content.

There are currently no P32x atomic functions defined. P32x_CP is defined only, supporting fixed interconnections.

12 P31x path layer functions

P31x layer CP

The Characteristic Information CI at this point is a 34 368 kbit/s bit stream of any content; e.g. P31s, P31e, or without standardized frame.

There are currently no P31x atomic functions defined. P31x_CP is defined only, supporting fixed interconnections.

13 P22x path layer functions

P22x layer CP

The Characteristic Information CI at this point is a 8 448 kbit/s bit stream of any content; e.g. P22e, or without standardized frame.

There are currently no P22x atomic functions defined. P22x_CP is defined only, supporting fixed interconnections.

14 P12x path layer functions

P12x layer CP

The Characteristic Information CI at this point is a 2 048 kbit/s bit stream of any content; e.g. P12s, ISDN PRA, or without standardized frame.

There are currently no P12x atomic functions defined. P12x_CP is defined only, supporting fixed interconnections.

15 P11x path layer functions

P11x layer CP

The Characteristic Information CI at this point is a 1 544 kbit/s bit stream of any content.

There are currently no P11x atomic functions defined. P11x_CP is defined only, supporting fixed interconnections.

16 P0 path layer functions

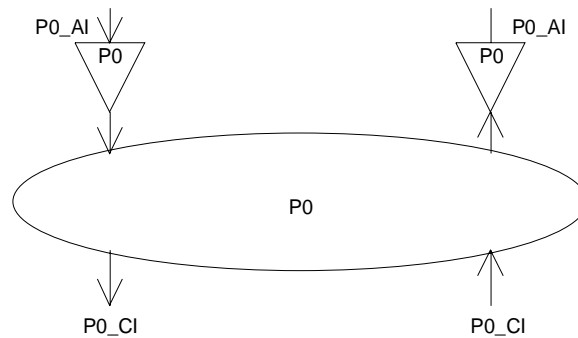

Figure 162: P0 Atomic Functions

P0 layer CP

The CI at this point is a synchronous 64 kbit/s byte structured signal with co-directional bit timing and the frame start information FS. The CI is structured as 8 bit numbered 1 to 8. Figure 163 depicts the structure.

P0 layer AP

The signal transported by a P0 will be determined by the client layer application. Typical signals include:

- an ITU-T Recommendation G.711 A-law coded speech
- an ITU-T Recommendation G.711 μ -law coded speech
- a 64 kbit/s data channel
- a 56 kbit/s data channel

NOTE 1: Many more compositions exist which are not addressed in the present document.

Figure 164 shows that more than one adaptation function exists in this P0 layer that can be connected to one P0 access point. For the case of the adaptation source functions, only one of these adaptation source functions is allowed to be activated. For this activated source, access to the access point by other adaptation source functions must be denied. In contradiction with the source direction, adaptation sink functions may be activated all together. This may cause faults to be detected and reported. To prevent this an adaptation sink function can be deactivated.

NOTE 2: If one adaptation function only is connected to the AP, it will be activated. If one or more other functions are connected to the same AP, one out of the set of functions will be active

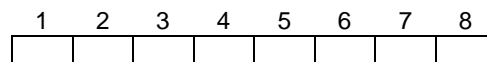

Figure 163: Structure of the P0_CI_D signal

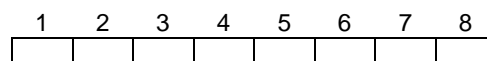

Figure 164: Structure of the P0_AI_D signal

16.1 P0 connection functions

16.1.1 P0 Trail Connection Function (P0_C)

P0_C is the function which assigns P0 at its input ports P0 at its output ports.

The P0_C connection process is an unidirectional function as illustrated in figure 165. The signal formats at the input and output ports of the function are similar, differing only in the coding of the P0. As the process does not affect the nature of the characteristic information of the signal, the reference point on either side of the P0_C function is the same, as illustrated in figure 165. The P0_C function is not timing transparent.

Incoming P0 at the P0_CP are assigned to available outgoing P0 capacity at the P0_CP.

An idle A-law or μ -law code shall be applied at any outgoing P0 which is not connected to an incoming P0_CP.

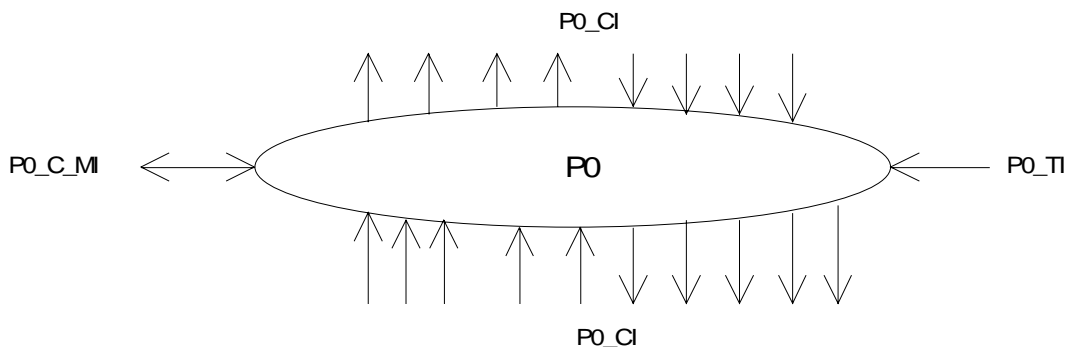

Figure 165: P0_0_C symbol

Interfaces:

Table 118: P0_C input and output signals

Input(s)	Output(s)
Per P0_CP, n x for the function: P0_CI_Data P0_CI_Clock P0_CI_FrameStart P0_CI_SSF	Per P0_CP, m x per function: P0_CI_Data P0_CI_Clock P0_CI_FrameStart P0_CI_SSF
1 x per function: T0_TI_Clock T0_TI_FrameStart	
Per input and output connection point: P0_C_MI_ConnectionPortIds	
Per matrix connection: P0_C_MI_ConnectionType P0_C_MI_Directionality	

Processes:

In the P0_C function P0 Layer Characteristic Information is routed between input (termination) connection points [(T)CPs] and output (T)CPs by means of matrix connections. (T)CPs may be allocated within a protection group.

NOTE 1: Neither the number of input/output signals to the connection function, nor the connectivity is specified in this Recommendation. That is a property of individual network elements.

Figure 162 presents a subset of the atomic functions that can be connected to this P0 connection function: P0 trail termination functions and adaptation functions. In addition, adaptation functions in the P0 server (e.g P12s or P11s) layers will be connected to this P0 connection function.

Routing: The function shall be able to connect a specific input with a specific output by means of establishing a matrix connection between the specified input and output. It shall be able to remove an established matrix connection.

Each (matrix) connection in the P0_C function shall be characterized by the:

Traffic direction	unidirectional, bi-directional;
Input and output connection points	set of connection point identifiers (refer to EN 300 417-1-1 [9], clause 3.3.6).

NOTE 2: Broadcast connections are handled as separate connections to the same input CP.

The addition and removal of connections to/from a broadcast shall be possible without disturbing the CI passing the connection:

Idle pattern generation: The function shall generate an idle A-law or m-law coded P0 signal, as specified in ITU-T Recommendation Q.522 clause 2.12.

Defects: None.

Consequent Actions:

If an output of this function is not connected to one of its inputs, the function shall connect the idle P0 (with valid frame start (FS) and SSF = false) to the output.

Defect Correlations: None.

Performance Monitoring: None.

17 P0 trail termination functions

For further study.

18 P0-31c path layer functions

P0-31c layer CP

The Characteristic Information CI at this point is a 1984 kbit/s bit stream of any content.

There are currently no P0-31c atomic functions defined. P0-31c_CP is defined only, supporting fixed interconnections.

Annex A (informative): Relationship between TU-2/12 address, and location of columns within a P4s TUG3 structured payload

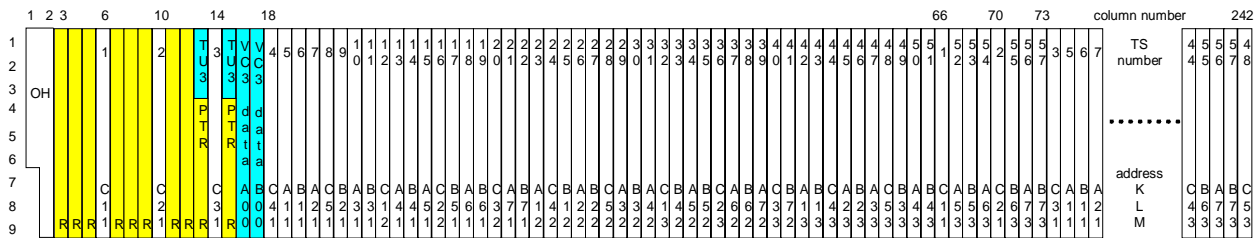

Figure A.1: P4s TUG3 payload (TUGs and fixed stuff "R" bytes)

Table A.1

TU-3 address			location of columns in a P4s-TUG3 occupied by TU-3 (K, L, M)											
K	L	M												
A	0	0	13	16	19	21	24	27	29	32	35	37	40	43
			45	48	51	53	56	59	61	64	67	69	72	75
			77	80	83	85	88	91	93	96	99	101	104	107
			109	112	115	117	120	123	125	128	131	133	136	139
			141	144	147	149	152	155	157	160	163	165	168	171
			173	176	179	181	184	187	189	192	195	197	200	203
			205	208	211	213	216	219	221	224	227	229	232	235
B	0	0	15	17	20	23	25	28	31	33	36	39	41	44
			47	49	52	55	57	60	63	65	68	71	73	76
			79	81	84	87	89	92	95	97	100	103	105	108
			111	113	116	119	121	124	127	129	132	135	137	140
			143	145	148	151	153	156	159	161	164	167	169	172
			175	177	180	183	185	188	191	193	196	199	201	204
			207	209	212	215	217	220	223	225	228	231	233	236
			239	241										

Table A.2

TU-2 address			location of columns in a P4s-TUG3 occupied by TU-2 (K, L, M)											
K	L	M	1	2	3	4	5	6	7	8	9	10	11	12
A	1	0	19	37	56	75	93	112	131	149	168	187	205	224
A	2	0	21	40	59	77	96	115	133	152	171	189	208	227
A	3	0	24	43	61	80	99	117	136	155	173	192	211	229
A	4	0	27	45	64	83	101	120	139	157	176	195	213	232
A	5	0	29	48	67	85	104	123	141	160	179	197	216	235
A	6	0	32	51	69	88	107	125	144	163	181	200	219	237
A	7	0	35	53	72	91	109	128	147	165	184	203	221	240
B	1	0	20	39	57	76	95	113	132	151	169	188	207	225
B	2	0	23	41	60	79	97	116	135	153	172	191	210	228
B	3	0	25	44	63	81	100	119	137	156	175	193	212	231
B	4	0	28	47	65	84	103	121	140	159	177	196	215	233
B	5	0	31	49	68	87	105	124	143	161	180	199	218	236
B	6	0	33	52	71	89	108	127	145	164	183	201	220	239
B	7	0	36	55	73	92	111	129	148	167	185	204	223	241
C	1	0	6	26	46	66	86	106	126	146	166	186	206	226
C	2	0	10	30	50	70	90	110	130	150	170	190	210	230
C	3	0	14	34	54	74	94	114	134	154	174	194	214	234
C	4	0	18	38	58	78	98	118	138	158	178	198	218	238
C	5	0	22	42	62	82	102	122	142	162	182	202	222	242

Table A.3: (every 56th column)

TU-12 address			location of columns in a P4sTUG3			
K	L	M	occupied by TU-12 (K, L, M)			
A	1	1	19	75	131	187
A	1	2	37	93	149	205
A	1	3	56	112	168	224
A	2	1	21	77	133	189
A	2	2	40	96	152	208
A	2	3	59	115	171	227
A	3	1	24	80	136	192
A	3	2	43	99	155	211
A	3	3	61	117	173	229
A	4	1	27	83	139	195
A	4	2	45	101	157	213
A	4	3	64	120	176	232
A	5	1	29	85	141	197
A	5	2	48	104	160	216
A	5	3	67	123	179	235
A	6	1	32	88	144	200
A	6	2	51	107	163	219
A	6	3	69	125	181	237
A	7	1	35	91	147	203
A	7	2	53	109	165	221
A	7	3	72	128	184	240

Table A.4: (every 56th column)

TU-12 address			location of columns in a P4sTUG3			
K	L	M	occupied by TU-12 (K, L, M)			
B	1	1	20	76	132	188
B	1	2	39	95	151	207
B	1	3	57	113	169	225
B	2	1	23	79	135	191
B	2	2	41	97	153	210
B	2	3	60	116	172	228
B	3	1	25	81	137	193
B	3	2	44	100	156	212
B	3	3	63	119	175	231
B	4	1	28	84	140	196
B	4	2	47	103	159	215
B	4	3	65	121	177	233
B	5	1	31	87	143	199
B	5	2	49	105	161	218
B	5	3	68	124	180	236
B	6	1	33	89	145	201
B	6	2	52	108	164	220
B	6	3	71	127	183	239
B	7	1	36	92	148	204
B	7	2	55	111	167	223
B	7	3	73	129	185	241

Table A.5: (every 60th column)

TU-12 address			location of columns in a P4sTUG3			
K	L	M	occupied by TU-12 (K, L, M)			
C	1	1	6	66	126	186
C	1	2	26	86	146	206
C	1	3	46	106	166	226
C	2	1	10	70	130	190
C	2	2	30	90	150	210
C	2	3	50	110	170	230
C	3	1	14	74	134	194
C	3	2	34	94	154	214
C	3	3	54	114	174	234
C	4	1	18	78	138	198
C	4	2	38	98	158	218
C	4	3	58	118	178	238
C	5	1	22	82	142	202
C	5	2	42	102	162	222
C	5	3	62	122	182	242

Annex B (informative): Relationship between TU-2/12 address, and location of columns within a P4s TUG2 structured payload

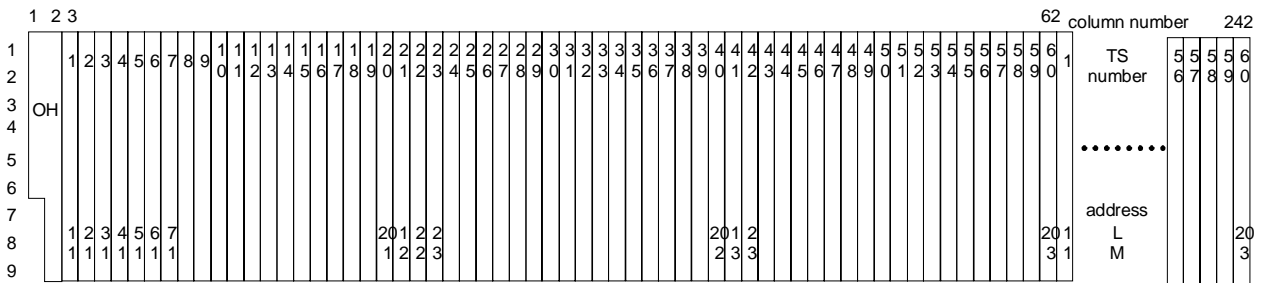

Figure B.1: P4s TUG2 payload (20 x TUG2)

Table B.1

TU-2 address		location of columns in a P4s-TUG2 occupied by TU-2 (K, L, M)											
L	M	1	2	3	4	5	6	7	8	9	10	11	12
1	0	3	23	43	63	83	103	123	143	163	183	203	223
2	0	4	24	44	64	84	104	124	144	164	184	204	224
3	0	5	25	45	65	85	105	125	145	165	185	205	225
4	0	6	26	46	66	86	106	126	146	166	186	206	226
5	0	7	27	47	67	87	107	127	147	167	187	207	227
6	0	8	28	48	68	88	108	128	148	168	188	208	228
7	0	9	29	49	69	89	109	129	149	169	189	209	229
8	0	10	30	50	70	90	110	130	150	170	190	210	230
9	0	11	31	51	71	91	111	131	151	171	191	211	231
10	0	12	32	52	72	92	112	132	152	172	192	212	232
11	0	13	33	53	73	93	113	133	153	173	193	213	233
12	0	14	34	54	74	94	114	134	154	174	194	214	234
13	0	15	35	55	75	95	115	135	155	175	195	215	235
14	0	16	36	56	76	96	116	136	156	176	196	216	236
15	0	17	37	57	77	97	117	137	157	177	197	217	237
16	0	18	38	58	78	98	118	138	158	178	198	218	238
17	0	19	39	59	79	99	119	139	159	179	199	219	239
18	0	20	40	60	80	100	120	140	160	180	200	220	240
19	0	21	41	61	81	101	121	141	161	181	201	221	241
20	0	22	42	62	82	102	122	142	162	182	202	222	242

Table B.2: (every 60th column)

TU-12 address		location of columns in a P4sTUG2			
L	M	occupied by TU-12 (L, M)			
1	1	3	63	123	183
1	2	23	83	143	203
1	3	43	103	163	223
2	1	4	64	124	184
2	2	24	84	144	204
2	3	44	104	164	224
3	1	5	65	125	185
3	2	25	85	145	205
3	3	45	105	165	225
4	1	6	66	126	186
4	2	26	86	146	206
4	3	46	106	166	226
5	1	7	67	127	187
5	2	27	87	147	207
5	3	47	107	167	227
6	1	8	68	128	188
6	2	28	88	148	208
6	3	48	108	168	228
7	1	9	69	129	189
7	2	29	89	149	209
7	3	49	109	169	229

Table B.3: (every 60th column)

TU-12 address		location of columns in a P4sTUG2			
L	M	occupied by TU-12 (L, M)			
8	1	10	70	130	190
8	2	30	90	150	210
8	3	50	110	170	230
9	1	11	71	131	191
9	2	31	91	151	211
9	3	51	111	171	231
10	1	12	72	132	192
10	2	32	92	152	212
10	3	52	112	172	232
11	1	13	73	133	193
11	2	33	93	153	213
11	3	53	113	173	233
12	1	14	74	134	194
12	2	34	94	154	214
12	3	54	114	174	234
13	1	15	75	135	195
13	2	35	95	155	215
13	3	55	115	175	235
14	1	16	76	136	196
14	2	36	96	156	216
14	3	56	116	176	236

Table B.4: (every 60th column)

TU-12 address		location of columns in a P4sTUG2			
L	M	occupied by TU-12 (L, M)			
15	1	17	77	137	197
15	2	37	97	157	217
15	3	57	117	177	237
16	1	18	78	138	198
16	2	38	98	158	218
16	3	58	118	178	238
17	1	19	79	139	199
17	2	39	99	159	219
17	3	59	119	179	239
18	1	20	80	140	200
18	2	40	100	160	220
18	3	60	120	180	240
19	1	21	81	141	201
19	2	41	101	161	221
19	3	61	121	181	241
20	1	22	82	142	202
20	2	42	102	162	222
20	3	62	122	182	242

Annex C (informative): Bibliography

ETSI EN 300 462: "Transmission and Multiplexing (TM); Generic requirements for synchronization networks".

ITU-T Recommendation G.803: "Architecture of transport networks based on the synchronous digital hierarchy (SDH)".

ITU-T Recommendation G.783: "Characteristics of synchronous digital hierarchy (SDH) equipment functional blocks".

ITU-T Recommendation G.811: "Timing characteristics of primary reference clocks".

ITU-T Recommendation G.821: "Error performance of an international digital connection forming part of an integrated services digital network".

ITU-T Recommendation G.825: "The control of jitter and wander within digital networks which are based on the synchronous digital hierarchy (SDH)".

ITU-T Recommendation G.826: "Error performance parameters and objectives for international, constant bit rate digital paths at or above the primary rate".

History

Document history		
Edition 1	March 1998	Publication as ETS 300 417-5-1
V1.1.2	November 1998	Publication
V1.1.3	May 1999	Publication
V1.2.1	June 2001	One-step Approval Procedure OAP 20011012: 2001-06-13 to 2001-10-12