

**Transmission and Multiplexing (TM);
Generic requirements of transport functionality of equipment;
Part 2-1: Synchronous Digital Hierarchy (SDH) and
Plesiochronous Digital Hierarchy (PDH)
physical section layer functions**



Reference

REN/TM-01042-2-1

Keywords

Architecture, SDH, transmission, interface

ETSI

650 Route des Lucioles
F-06921 Sophia Antipolis Cedex - FRANCE

Tel.: +33 4 92 94 42 00 Fax: +33 4 93 65 47 16

Siret N° 348 623 562 00017 - NAF 742 C
Association à but non lucratif enregistrée à la
Sous-Préfecture de Grasse (06) N° 7803/88

Important notice

Individual copies of the present document can be downloaded from:

<http://www.etsi.org>

The present document may be made available in more than one electronic version or in print. In any case of existing or perceived difference in contents between such versions, the reference version is the Portable Document Format (PDF). In case of dispute, the reference shall be the printing on ETSI printers of the PDF version kept on a specific network drive within ETSI Secretariat.

Users of the present document should be aware that the document may be subject to revision or change of status. Information on the current status of this and other ETSI documents is available at <http://www.etsi.org/tb/status/>

If you find errors in the present document, send your comment to:
editor@etsi.fr

Copyright Notification

No part may be reproduced except as authorized by written permission.
The copyright and the foregoing restriction extend to reproduction in all media.

© European Telecommunications Standards Institute 2001.
All rights reserved.

Contents

Intellectual Property Rights	6
Foreword.....	6
1 Scope.....	8
2 References.....	8
3 Definitions, abbreviations and symbols	9
3.1 Definitions	9
3.2 Abbreviations.....	9
3.3 Symbols and diagrammatic conventions.....	11
3.4 Introduction.....	11
4 STM-1 Optical Section Layer Functions	12
4.1 Optical Section Connection functions	13
4.2 Optical Section Trail Termination functions.....	13
4.2.1 Optical Section Trail Termination Source OS1-Xy.z_TT_So	13
4.2.2 Optical Section Trail Termination Sink OS1-Xy.z_TT_Sk.....	14
4.3 Optical Section Adaptation functions.....	15
4.3.1 Optical Section to Regenerator Section Adaptation Source OS1/RS1_A_So.....	15
4.3.2 Optical Section to Regenerator Section Adaptation Sink OS1/RS1_A_Sk	16
5 STM-4 Optical Section Layer Functions	18
5.1 Optical Section Connection functions	18
5.2 Optical Section Trail Termination functions.....	19
5.2.1 Optical Section Trail Termination Source OS4-Xy.z_TT_So	19
5.2.2 Optical Section Trail Termination Sink OS4-Xy.z_TT_Sk.....	20
5.3 Optical Section Adaptation functions.....	21
5.3.1 Optical Section to Regenerator Section Adaptation Source OS4/RS4_A_So.....	21
5.3.2 Optical Section to Regenerator Section Adaptation Sink OS4/RS4_A_Sk	22
6 STM-16 Optical Section Layer Functions	23
6.1 Optical Section Connection functions	24
6.2 Optical Section Trail Termination functions.....	24
6.2.1 Optical Section Trail Termination Source OS16-Xy.z_TT_So	24
6.2.2 Optical Section Trail Termination Sink OS16-Xy.z_TT_Sk.....	24
6.3 Optical Section Adaptation functions.....	26
6.3.1 Optical Section to Regenerator Section Adaptation Source OS16/RS16_A_So.....	26
6.3.2 Optical Section to Regenerator Section Adaptation Sink OS16/RS16_A_Sk.....	27
7 STM-64 Optical Section Layer Functions	28
7.1 Optical Section Connection functions	29
7.2 Optical Section Trail Termination functions.....	29
7.2.1 Optical Section Trail Termination Source OS64-Xy.z_TT_So	29
7.2.2 Optical Section Trail Termination Sink OS64-Xy.z_TT_Sk.....	30
7.3 Optical Section Adaptation functions.....	31
7.3.1 Optical Section to Regenerator Section Adaptation Source OS64/RS64_A_So.....	31
7.3.2 Optical Section to Regenerator Section Adaptation Sink OS64/RS64_A_Sk.....	32
8 STM-256 Optical Section Layer Functions.....	33
8.1 Optical Section Connection functions	34
8.2 Optical Section Trail Termination functions.....	34
8.2.1 Optical Section Trail Termination Source OS256-Xy.z_TT_So.....	34
8.2.2 Optical Section Trail Termination Sink OS256-Xy.z_TT_Sk.....	35
8.3 Optical Section Adaptation functions.....	36
8.3.1 Optical Section to Regenerator Section Adaptation Source OS256/RS256_A_So	36
8.3.2 Optical Section to Regenerator Section Adaptation Sink OS256/RS256_A_Sk.....	37
9 STM-1 Electrical Section Layer Functions	38
9.1 STM-1 Electrical Section Connection function ES1_C.....	39

9.2	STM-1 Electrical Section Trail Termination functions.....	39
9.2.1	STM-1 Electrical Section Trail Termination Source ES1_TT_So.....	39
9.2.2	STM-1 Electrical Section Trail Termination Sink ES1_TT_Sk.....	40
9.3	STM-1 Electrical Section Adaptation functions.....	41
9.3.1	STM-1 Electrical Section to Regenerator Section Adaptation Source ES1/RS1_A_So.....	41
9.3.2	STM-1 Electrical Section to Regenerator Section Adaptation Sink ES1/RS1_A_Sk.....	42
10	E4 Section Layer Functions	43
10.1	E4 Connection function E4_C.....	44
10.2	E4 Trail Termination functions.....	45
10.2.1	E4 Trail Termination Source E4_TT_So.....	45
10.2.2	E4 Trail Termination Sink E4_TT_Sk.....	46
10.3	E4 Adaptation functions	47
10.3.1	E4 to P4x Adaptation Source E4/P4x_A_So.....	47
10.3.2	E4 to P4x Adaptation Sink E4/P4x_A_Sk.....	48
10.3.3	E4 to P4e Adaptation Source E4/P4e_A_So.....	49
10.3.4	E4 to P4e Adaptation Sink E4/P4e_A_Sk.....	50
10.3.5	E4 to P4s Adaptation Source E4/P4s_A_So.....	51
10.3.6	E4 to P4s Adaptation Sink E4/P4s_A_Sk.....	52
11	E31 Section Layer Functions	54
11.1	E31 Connection function E31_C.....	55
11.2	E31 Trail Termination functions.....	55
11.2.1	E31 Trail Termination Source E31_TT_So.....	55
11.2.2	E31 Trail Termination Sink E31_TT_Sk.....	56
11.3	E31 Adaptation functions	57
11.3.1	E31 to P31x Adaptation Source E31/P31x_A_So.....	57
11.3.2	E31 to P31x Adaptation Sink E31/P31x_A_Sk.....	58
11.3.3	E31 to P31e Adaptation Source E31/P31e_A_So.....	59
11.3.4	E31 to P31e Adaptation Sink E31/P31e_A_Sk.....	60
11.3.5	E31 to P31s Adaptation Source E31/P31s_A_So.....	61
11.3.6	E31 to P31s Adaptation Sink E31/P31s_A_Sk.....	62
12	E22 Section Layer Functions	64
12.1	E22 Connection function E22_C.....	65
12.2	E22 Trail Termination functions.....	65
12.2.1	E22 Trail Termination Source E22_TT_So.....	65
12.2.2	E22 Trail Termination Sink E22_TT_Sk.....	66
12.3	E22 Adaptation functions	67
12.3.1	E22 to P22x Adaptation Source E22/P22x_A_So.....	67
12.3.2	E22 to P22x Adaptation Sink E22/P22x_A_Sk.....	68
12.3.3	E22 to P22e Adaptation Source E22/P22e_A_So.....	69
12.3.4	E22 to P22e Adaptation Sink E22/P22e_A_Sk.....	70
13	E12 Section Layer Functions	71
13.1	E12 Connection function E12_C.....	73
13.2	E12 Trail Termination functions.....	73
13.2.1	E12 Trail Termination Source E12-Z_TT_So.....	73
13.2.2	E12 Trail Termination Sink E12-Z_TT_Sk.....	74
13.3	E12 Adaptation functions	75
13.3.1	E12 to P12x Adaptation Source E12/P12x_A_So.....	75
13.3.2	E12 to P12x Adaptation Sink E12/P12x_A_Sk.....	76
13.3.3	E12 to P12s Adaptation Source E12/P12s_A_So.....	77
13.3.4	E12 to P12s Adaptation Sink E12/P12s_A_Sk.....	78
14	T12 Section Layer Functions	80
14.1	T12 Connection function T12_C.....	80
14.2	T12 Trail Termination functions.....	80
14.2.1	T12 Trail Termination Source T12-Z_TT_So.....	80
14.2.2	T12 Trail Termination Sink T12-Z_TT_Sk.....	82
14.3	T12 Adaptation functions	83
14.3.1	T12 to SD Adaptation Source T12/SD_A_So.....	83
14.3.2	T12 to SD Adaptation Sink T12/SD_A_Sk.....	83

15	E0 Section Layer Functions	83
15.1	E0 Connection function E0_C.....	83
15.2	E0 Trail Termination functions	84
15.2.1	E0 Trail Termination Source E0_TT_So.....	84
15.2.2	E0 Trail Termination Sink E0_TT_Sk.....	85
15.3	E0 Adaptation functions	86
15.3.1	E0 to P0s Adaptation Source E0/P0s_A_So.....	86
15.3.2	E0 to P0s Adaptation Sink E0/P0s_A_Sk.....	87
Annex A (informative): E32 Section Layer Functions		89
A.1	E32 Connection function E32_C.....	89
A.2	E32 Trail Termination functions	90
A.2.1	E32 Trail Termination Source E32_TT_So	90
A.2.2	E32 Trail Termination Sink E32_TT_Sk.....	91
A.3	E32 Adaptation functions.....	92
A.3.1	E32 to P32x Adaptation Source E32/P32x_A_So.....	92
A.3.2	E32 to P32x Adaptation Sink E32/P32x_A_Sk	93
Annex B (informative): E11 Section Layer Functions		94
B.1	E11 Connection function E11_C.....	94
B.2	E11 Trail Termination functions	94
B.2.1	E11 Trail Termination Source E11_TT_So	94
B.2.2	E11 Trail Termination Sink E11_TT_Sk.....	95
B.3	E11 Adaptation functions.....	96
B.3.1	E11 to P11x Adaptation Source E11/P11x-L_A_So	96
B.3.2	E11 to P11x Adaptation Sink E11/P11x-L_A_Sk.....	97
Annex C (informative): Bibliography.....		98
History		99

Intellectual Property Rights

IPRs essential or potentially essential to the present document may have been declared to ETSI. The information pertaining to these essential IPRs, if any, is publicly available for **ETSI members and non-members**, and can be found in ETSI SR 000 314: *"Intellectual Property Rights (IPRs); Essential, or potentially Essential, IPRs notified to ETSI in respect of ETSI standards"*, which is available from the ETSI Secretariat. Latest updates are available on the ETSI Web server (<http://www.etsi.org/ipr>).

Pursuant to the ETSI IPR Policy, no investigation, including IPR searches, has been carried out by ETSI. No guarantee can be given as to the existence of other IPRs not referenced in ETSI SR 000 314 (or the updates on the ETSI Web server) which are, or may be, or may become, essential to the present document.

Foreword

This European Standard (Telecommunications series) has been produced by ETSI Technical Committee Transmission and Multiplexing (TM), and is now submitted for the ETSI standards One-step Approval Procedure.

The present document is one of a family of documents that has been produced in order to provide inter-vendor and inter-operator compatibility of Synchronous Digital Hierarchy (SDH) equipment.

The present document is part 2-1 of a multi-part EN covering the Generic requirements of transport functionality of equipment, as identified:

Part 1-1: "Generic processes and performance".

Part 1-2: "General information about Implementation Conformance Statement (ICS) proforma".

Part 2-1: "Synchronous Digital Hierarchy (SDH) and Plesiochronous Digital Hierarchy (PDH) physical section layer functions".

Part 2-2: "Synchronous Digital Hierarchy (SDH) and Plesiochronous Digital Hierarchy (PDH) physical section layer functions; Implementation Conformance Statement (ICS) proforma specification".

Part 3-1: "Synchronous Transport Module-N (STM-N) regenerator and multiplex section layer functions".

Part 3-2: "Synchronous Transport Module-N (STM-N) regenerator and multiplex section layer functions; Implementation Conformance Statement (ICS) proforma specification".

Part 4-1: "Synchronous Digital Hierarchy (SDH) path layer functions".

Part 4-2: "Synchronous Digital Hierarchy (SDH) path layer functions; Implementation Conformance Statement (ICS) proforma specification".

Part 5-1: "Plesiochronous Digital Hierarchy (PDH) path layer functions".

Part 5-2: "Plesiochronous Digital Hierarchy (PDH) path layer functions; Implementation Conformance Statement (ICS) proforma specification".

Part 6-1: "Synchronization layer functions".

Part 6-2: "Synchronization layer functions; Implementation Conformance Statement (ICS) proforma specification".

Part 7-1: "Equipment Management and Auxiliary layer functions".

Part 7-2: "Equipment Management and Auxiliary layer functions; Implementation Conformance Statement (ICS) proforma specification".

Part 9-1: "Synchronous Digital Hierarchy (SDH) concatenated path layer functions; Requirements".

Parts 2 to 7 specify the layers and their atomic functions.

NOTE: The SDH radio equipment functional blocks are addressed by ETSI WG TM4.

Various of the above parts have previously been published as parts of EN 300 417.

They have been converted to parts of EN 300 417 without technical changes, but some editorial changes have been necessary (e.g. references). In particular:

- Parts 2-1 and 3-2 have been modified to take account of editorial errors present in edition 1.
- Part 1-1 has had its title change of to align with other parts published at a later date.

Also note that in the meantime parts 8-1, 8-2 and 8-3 have been stopped.

Proposed national transposition dates	
Date of latest announcement of this EN (doa):	3 months after ETSI publication
Date of latest publication of new National Standard or endorsement of this EN (dop/e):	6 months after doa
Date of withdrawal of any conflicting National Standard (dow):	6 months after doa

1 Scope

The present document specifies a library of basic building blocks and a set of rules by which they are combined in order to describe transport functionality of equipment. The library comprises the functional building blocks needed to completely specify the generic functional structure of the European transmission hierarchies. Equipment which is compliant with the present document needs to be describable as an interconnection of a subset of these functional blocks contained within the present document. The interconnections of these blocks need to obey the combination rules given. The generic functionality is described in the EN 300 417-1-1 [8].

2 References

The following documents contain provisions which, through reference in this text, constitute provisions of the present document.

- References are either specific (identified by date of publication, edition number, version number, etc.) or non-specific.
- For a specific reference, subsequent revisions do not apply.
- For a non-specific reference, the latest version applies.

- [1] ANSI T1.102: "Telecommunications; Digital Hierarchy; Electrical Interfaces".
- [2] ANSI T1.107: "Telecommunications; Digital Hierarchy; Formats Specifications".
- [3] ETSI ETS 300 147: "Transmission and Multiplexing (TM); Synchronous Digital Hierarchy (SDH); Multiplexing structure".
- [4] ETSI ETS 300 166: "Transmission and Multiplexing (TM); Physical and electrical characteristics of hierarchical digital interfaces for equipment using the 2 048 kbit/s - based plesiochronous or synchronous digital hierarchies".
- [5] ETSI ETS 300 167: "Transmission and Multiplexing (TM); Functional characteristics of 2 048 kbit/s interfaces".
- [6] ITU-T Recommendation G.957 (1999): "Optical interfaces for equipments and systems relating to the synchronous digital hierarchy".

NOTE: The former version of G.957 was modified and published under ETSI ETS 300 236 (1996). As no revision is ongoing, the ITU Reference is preferred.

- [7] ETSI ETS 300 337: "Transmission and Multiplexing (TM); Generic frame structures for the transport of various signals (including Asynchronous Transfer Mode (ATM) cells and Synchronous Digital Hierarchy (SDH) elements) at the ITU-T Recommendation G.702 hierarchical rates of 2 048 kbit/s, 34 368 kbit/s and 139 264 kbit/s".
- [8] ETSI EN 300 417-1-1: "Transmission and Multiplexing (TM); Generic requirements of transport functionality of equipment; Part 1-1: Generic processes and performance".
- [9] ETSI EN 300 417-6-1: "Transmission and Multiplexing (TM); Generic requirements of transport functionality of equipment; Part 6-1: Synchronization layer functions".
- [10] ITU-T Recommendation G.703: "Physical/electrical characteristics of hierarchical digital interfaces".
- [11] ITU-T Recommendation G.706: "Frame alignment and cyclic redundancy check (CRC) procedures relating to basic frame structures defined in recommendation G.704".
- [12] ITU-T Recommendation G.742 (1988): "Second order digital multiplex equipment operating at 8 448 kbit/s and using positive justification".

- [13] ITU-T Recommendation G.751 (1988): "Digital multiplex equipments operating at the third order bit rate of 34 368 kbit/s and the fourth order bit rate of 139 264 kbit/s and using positive justification".
- [14] ITU-T Recommendation G.775: "Loss of signal (LOS) and alarm indication signal (AIS) defect detection and clearance criteria".
- [15] ITU-T Recommendation G.823: "The control of jitter and wander within digital networks which are based on the 2 048 kbit/s hierarchy".
- [16] ITU-T Recommendation G.825: "The control of jitter and wander within digital networks which are based on the synchronous digital hierarchy (SDH)".
- [17] ITU-T Recommendation G.957: "Optical interfaces for equipments and systems relating to the synchronous digital hierarchy".
- [18] ITU-T Recommendation G.691: "Optical interfaces for single-channel SDH systems with Optical Amplifiers, and STM-64 systems".

3 Definitions, abbreviations and symbols

3.1 Definitions

The functional definitions are described in EN 300 417-1-1 [8].

3.2 Abbreviations

For the purposes of the present document, the following abbreviations apply:

A	Adaptation function
AI	Adapted Information
AIS	Alarm Indication Signal
ALS	Automatic Laser Shutdown
ANSI	American National Standards Institute
AP	Access Point
ATM	Asynchronous Transfer Mode
AU	Administrative Unit
BBE	Background Block Error
BER	Bit Error Rate
BFA	Basic Frame Alignment
BIP	Bit Interleaved Parity
C	Connection function
CH	CHannel
CI	Characteristic Information
CID	Consecutive Identical Digits
CK	ClocK
CM	Connection Matrix
CMI	Coded Mark Inversion
Co	Connection
CP	Connection Point
CRC	Cyclic Redundancy Check
D	Data
DEC	DECrement
DEG	DEGraded
DL	Data Link
E0	Electrical interface signal 64 kbit/s
E11	Electrical interface signal 1 544 kbit/s
E12	Electrical interface signal 2 048 kbit/s
E22	Electrical interface signal 8 448 kbit/s

E31	Electrical interface signal 34 368 kbit/s
E32	Electrical interface signal 44 736 kbit/s
E4	Electrical interface signal 139 264 kbit/s
EBC	Errored Block Count
ECC	Embedded Communications Channel
EDC	Error Detection Code
EQ	EQuipment
ES	Electrical Section
ES	Errored Second
ESR	Errored Seconds Rate
Ex	CCITT Recommendation G.703 [10] type electrical signal, bit rate order x
F_B	Far-end Block
F_SES	Far-end Severely Errored Second
FAS	Frame Alignment Signal
FO	Frame Offset information
FS	Frame Start signal
HDB3	High Density Bipolar of order 3
HO	Higher Order
ID	IDentifier
IF	In Frame state
INC	INCrement
IS	Intermediate System
ITU-T	International Telecommunications Union - Telecommunications Sector
LC	Link Connection
LO	Lower Order
LOF	Loss Of Frame
LOM	Loss Of Multiframe
LOP	Loss Of Pointer
LOS	Loss Of Signal
LOT	Loss of Octet Timing
LT	Line Termination
MC	Matrix Connection
MFP	MultiFrame Present
MI	Management Information
MO	Managed Object
MON	MONitored
MS	Multiplex Section
MS1	STM-1 Multiplex Section
MSP	Multiplex Section Protection
N_B	Near-end Block
N_SES	Near-end Severely Errored Second
NC	Network Connection
NCI	No CRC-4 to CRC-4 Interworking
NE	Network Element
NNI	Network Node Interface
NRZ	Non-Return to Zero
NU	National Use (bits, bytes)
OOF	Out Of Frame state
OS	Optical Section
OW	Order Wire
P	Protection
P0s	synchronous 64 kbit/s layer
P11x	1 544 kbit/s layer (transparent)
P12s	2 048 kbit/s PDH path layer with synchronous 125 µs frame structure according to ETS 300 167 [5]
P12x	2 048 kbit/s layer (transparent)
P22e	8 448 kbit/s PDH path layer with 4 plesiochronous 2 048 kbit/s
P22x	8 448 kbit/s layer (transparent)
P31e	34 368 kbit/s PDH path layer with 4 plesiochronous 8 448 kbit/s
P31s	34 368 kbit/s PDH path layer with synchronous 125 µs frame structure according to ETS 300 337 [7]
P31x	34 368 kbit/s layer (transparent)

P32x	44 736 kbit/s layer (transparent)
P4e	139 264 kbit/s PDH path layer with 4 plesiochronous 34 368 kbit/s
P4s	139 264 kbit/s PDH path layer with synchronous 125 µs frame structure according to ETS 300 337 [7]
P4x	139 264 kbit/s layer (transparent)
PDH	Plesiochronous Digital Hierarchy
PS	Protection Switching
RI	Remote Information
RLT	Regenerated Line Termination
RS	Regenerator Section
RS1	STM-1 Regenerator Section
RS16	STM-16 Regenerator Section
RS4	STM-4 Regenerator Section
S2	VC-2 path layer
S3	VC-3 path layer
S4	VC-4 path layer
SD	Synchronization Distribution layer, Signal Degrade
SDH	Synchronous Digital Hierarchy
SES	Severely Errored Second
SF	Signal Fail
SHR	Self Healing Ring
Sk	Sink
SNC	Sub-Network Connection
So	Source
SOH	Section OverHead
SSF	Server Signal Fail
STM	Synchronous Transport Module
STM-N	Synchronous Transport Module, level N
T12	2 048 kHz signal
TD	Transmit Degrade
TF	Transmit Fail
TG	Timing Generator
TI	Timing Information
TM	Transmission_Medium
TP	Timing Point
TR	Threshold Report
TS	Time Slot
TSF	Trail Signal Fail
TT	Trail Termination function
TU	Tributary Unit
TUG	Tributary Unit Group
UAT	UnAvailable Time
UAT_cmd	UnAvailable Time command
UI	Unit Interval
UNI	User to Network Interface
VC	Virtual Container
W	Working

3.3 Symbols and diagrammatic conventions

The symbols and diagrammatic conventions are described in EN 300 417-1-1 [8].

3.4 Introduction

The atomic functions defining the physical interface section layers are described below. They describe the physical and logical characteristics of the optical and electrical interfaces used in SDH equipments also with their adaptation functionality of PDH multiplex equipments described in the CCITT Recommendations G.751 [13] and G.742 [12] for signal hierarchies P4, P31 and P22, and adaptation functionality for SDH over PDH specified by ETS 300 337 [7] for signal hierarchies P4s and P31s and ETS 300 167 [5] for P12s layer signals.

The physical interface layers are defined for each of the synchronous and plesiochronous rates as defined in ETS 300 147 [3] and ETS 300 166 [4]. References to the signal structure are mentioned in the appropriate text subclauses.

4 STM-1 Optical Section Layer Functions

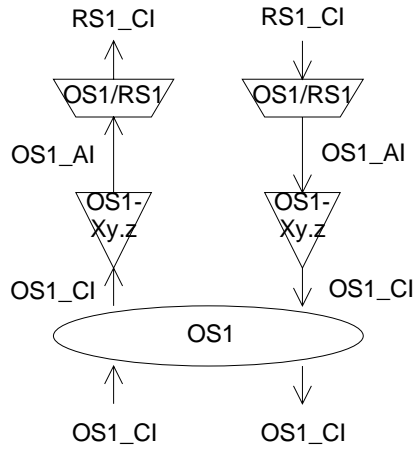

NOTE: Xy.z will be one value out of the set: {I1, S1.1, S1.2, L1.1, L1.2, L1.3}.

Figure 1: STM-1 Optical Section atomic functions

STM-1 Optical Section Layer CP

Characteristic Information OS1_CI of the optical layer CP (see figure 2) is a digital, optical signal of defined power, bit rate, pulse width and wavelength. A range of such characteristic signals for different optical power budgets is defined in ETS 300 232 [6].

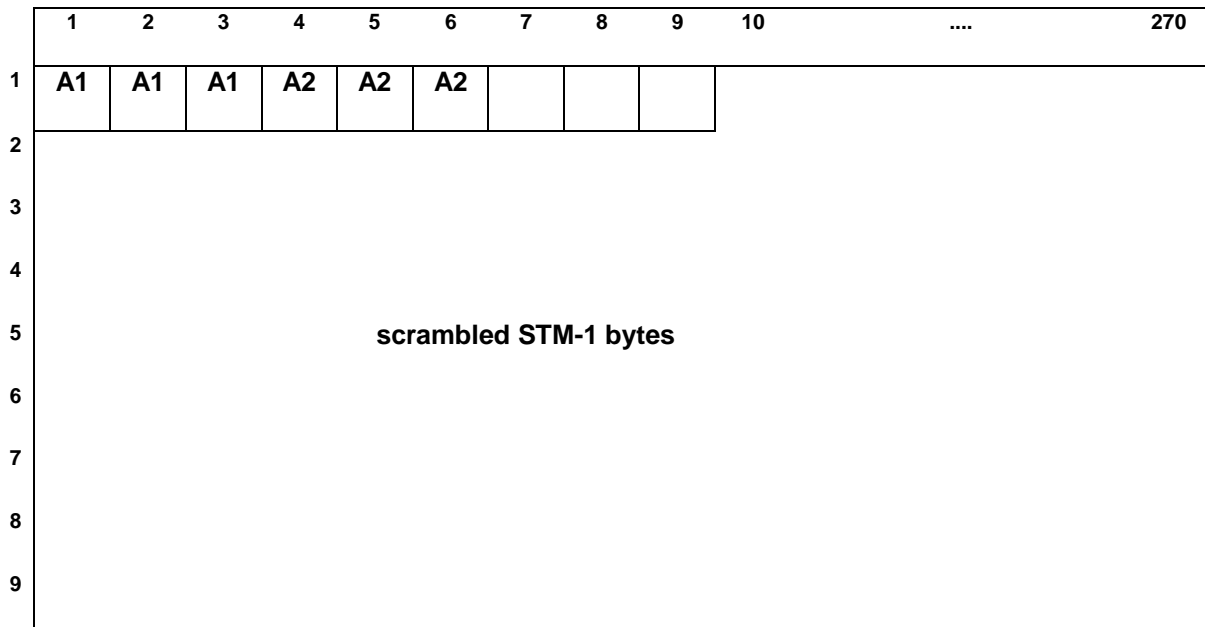

Figure 2: OS1 characteristic information OS1_CI (optical) and adapted information OS1_AI (electrical)

STM-1 Optical Section Layer AP

The information passing across the OS1 AP takes the form of a scrambled, digital bitstream (including a block frame character at 125 μ s intervals) with co-directional bit timing (see figure 2). Frame characters and the synchronous, scrambling polynomial are defined in ETS 300 147 [3].

4.1 Optical Section Connection functions

For further study.

4.2 Optical Section Trail Termination functions

4.2.1 Optical Section Trail Termination Source OS1-Xy.z_TT_So

NOTE: Xy.z will be one value out of the set: {I1, S1.1, S1.2, L1.1, L1.2, L1.3}.

Symbol:

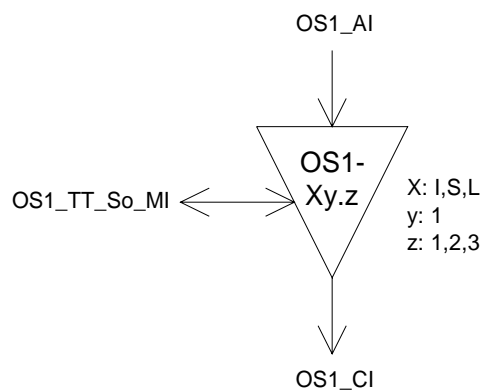

Figure 3: OS1-Xy.z_TT_So symbol

Interfaces:

Table 1: OS1-Xy.z_TT_So input and output signals

Input(s)	Output(s)
OS1_AI_D	OS1_CI_D

Processes:

This function forms the optical STM-1 signal for transmission over the optical cable as defined in ETS 300 232 [6].

Optical characteristics: The function shall generate an optical STM-1 signal that meets the Xy.z characteristics defined in ETS 300 232 [6].

Defects: None.

Consequent Actions: None.

Defect Correlations: None.

Performance Monitoring: None.

4.2.2 Optical Section Trail Termination Sink OS1-Xy.z_TT_Sk

NOTE 1: Xy.z will be one value out of the set: {I1, S1.1, S1.2, L1.1, L1.2, L1.3}.

Symbol:

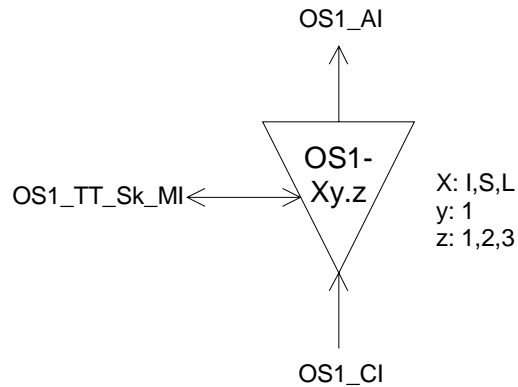

Figure 4: OS1-Xy.z_TT_Sk symbol

Interfaces:

Table 2: OS1-Xy.z_TT_Sk input and output signals

Input(s)	Output(s)
OS1_CI_D	OS1_AI_D OS1_AI_TSF
OS1_TT_Sk_MI_PortMode	OS1_TT_Sk_MI_cLOS

Processes:

This function recovers the optical STM-1 signal transmitted over the optical cables. The physical characteristics of the interface signal are defined in ETS 300 232 [6].

The function shall convert the received STM-1 signal, normally complying to the Xy.z characteristics defined in ETS 300 232 [6], into the internal OS1_AI signal.

Port Mode: The function shall have a port mode as specified by subclause 8.5 of EN 300 417-1-1 [8].

NOTE 2: The AUTO state of the port mode process is optional.

Defects:

The function shall detect Loss Of Signal defect (dLOS) according the optical STM-1 dLOS specification in subclause 8.2.1.6 of EN 300 417-1-1 [8].

Consequent Actions:

aTSF ← dLOS.

Defect Correlations:

cLOS ← MON and dLOS.

Performance Monitoring:

None.

4.3 Optical Section Adaptation functions

4.3.1 Optical Section to Regenerator Section Adaptation Source OS1/RS1_A_So

Symbol:

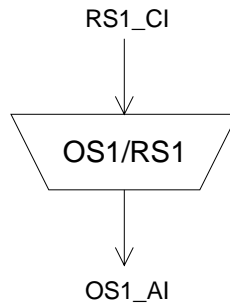

Figure 5: OS1/RS1_A_So symbol

Interfaces:

Table 3: OS1/RS1_A_So input and output signals

Input(s)	Output(s)
RS1_CI_D RS1_CI_CK	OS1_AI_D

Processes: None.

The function shall not add any jitter.

NOTE: Jitter at the NNI is the combination of the jitter generated and transferred via the client layers.

Defects: None.

Consequent Actions: None.

Defect Correlations: None.

Performance Monitoring: None.

4.3.2 Optical Section to Regenerator Section Adaptation Sink OS1/RS1_A_Sk

Symbol:

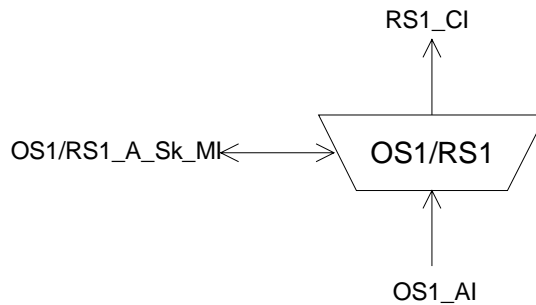

Figure 6: OS1/RS1_A_Sk symbol

Interfaces:

Table 4: OS1/RS1_A_Sk input and output signals

Input(s)	Output(s)
OS1_AI_D OS1_AI_TSF	RS1_CI_D RS1_CI_CK RS1_CI_FS RS1_CI_SSF OS1/RS1_A_Sk_MI_cLOF

Processes:

This function regenerates the received signal, recovers bit timing (CK) and Frame Start reference (FS) from the received signal.

Regeneration: The function shall operate with a maximum BER as specified in EN 300 417-1-1 [8], subclause 11.3.2.1 when any combination of the following signal conditions exist at the input:

- any input optical power level within the range specified in ETS 300 232 [6];
- jitter modulation applied to the input signal as specified in EN 300 417-1-1 [8], subclause 11.3.2.1;
- the input signal bit rate has any value in the range $155\,520\text{ kbit/s} \pm 20\text{ ppm}$.

NOTE: The frequency and jitter / wander tolerance might be further constrained by the requirements of the client layers.

To ensure adequate immunity against the presence of Consecutive Identical Digits (CID) in the STM-1 signal, the function shall comply with the specification in EN 300 417-1-1 [8], subclause 11.3.2.4.

The function shall process the signal such that in the absence of input jitter, the intrinsic jitter at the STM-1 output interface (in a regenerative repeater) shall not exceed:

- 0,3 UI peak-to-peak when measured through a bandpass filter with corner frequencies at 500 Hz and 1,3 MHz and low pass roll off of 60 dB / decade and high pass roll off of 20 dB / decade;
- 0,1 UI peak-to-peak when measured through a bandpass filter with corner frequencies at 65 kHz and 1,3 MHz and low pass roll off of 60 dB / decade and high pass roll off of 20 dB / decade.

NOTE: 1 UI = 6,43 ns

The function shall process the signal such that the jitter transfer (measured between an STM-1 input and STM-1 output in a regenerative repeater) shall be as specified in subclause 11.3.3.1 of EN 300 417-1-1 [8].

Frame alignment: The frame alignment shall be performed as specified in subclause 8.2.1.8 of EN 300 417-1-1 [8].

Defects:

The function shall detect for dLOF according the specification in subclause 8.2.1.8 of EN 300 417-1-1 [8].

Consequent Actions:

aAIS ← dLOF or AI_TSF;

aSSF ← dLOF or AI_TSF.

On declaration of an aAIS the function shall output an all-ONEs (AIS) signal - complying to the frequency limits for this interface - within 250 µs; on clearing of aAIS the function shall output normal data within 250 µs.

Defect Correlations:

cLOF ← dLOF and (not AI_TSF).

Performance Monitoring: None.

5 STM-4 Optical Section Layer Functions

NOTE: Xy.z will be one value out of the set: {I4, S4.1, S4.2, L4.1, L4.2, L4.3}.

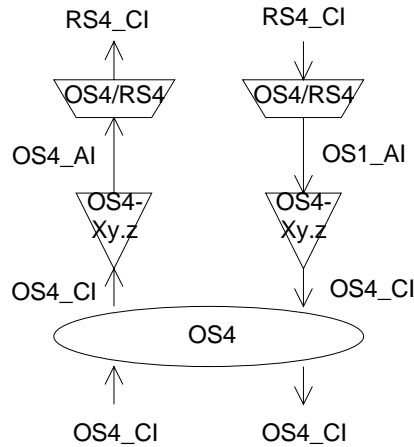

Figure 7: STM-4 Optical Section atomic functions

STM-4 Optical Section Layer CP

Characteristic Information OS4_CI of the optical layer CP (see figure 8) is a digital, optical signal of defined power, bit rate, pulse width and wavelength. A range of such characteristic signals for different optical power budgets is defined in ETS 300 232 [6].

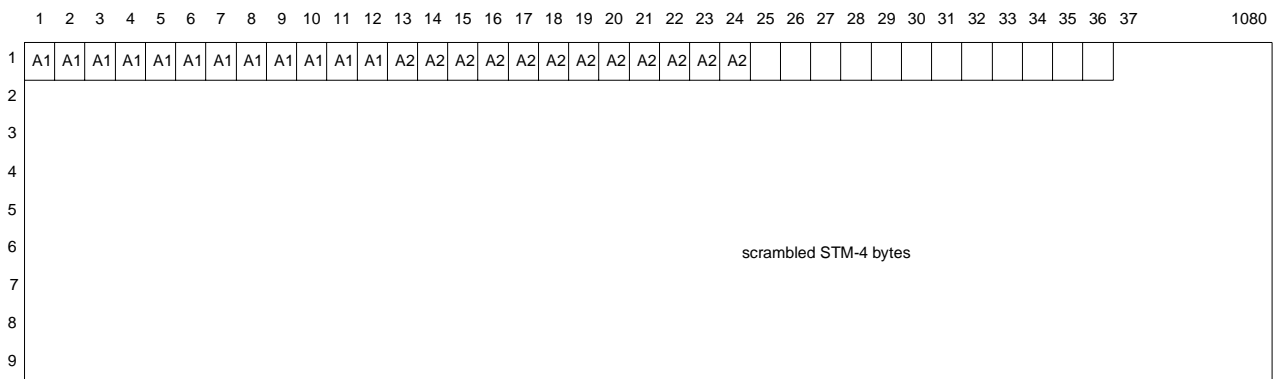

Figure 8: OS4 characteristic information OS4_CI (optical) and adapted information OS4_AI (electrical)

STM-4 Optical Section Layer AP

The information passing across the OS4 AP takes the form of a scrambled, digital bitstream (including a block frame character at 125 μs intervals) with co-directional bit timing (see figure 8). Frame characters and the synchronous, scrambling polynomial are defined in ETS 300 147 [3].

5.1 Optical Section Connection functions

For further study.

5.2 Optical Section Trail Termination functions

5.2.1 Optical Section Trail Termination Source OS4-Xy.z_TT_So

NOTE: Xy.z will be one value out of the set: {I4, S4.1, S4.2, L4.1, L4.2, L4.3}.

Symbol:

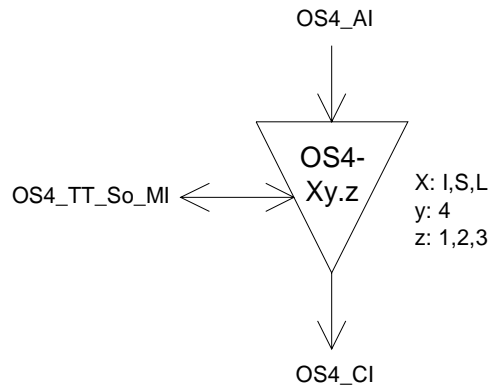

Figure 9: OS4-Xy.z_TT_So symbol

Interfaces:

Table 5: OS4-Xy.z_TT_So input and output signals

Input(s)	Output(s)
OS4_AI_D	OS4_CI_D

Processes:

This function forms the optical STM-4 signal for transmission over the optical cable as defined in ETS 300 232 [6].

Optical characteristics: The function shall generate an optical STM-4 signal that meets the Xy.z characteristics defined in ETS 300 232 [6].

Defects: None.

Consequent Actions: None.

Defect Correlations: None.

Performance Monitoring: None.

5.2.2 Optical Section Trail Termination Sink OS4-Xy.z_TT_Sk

NOTE 1: Xy.z will be one value out of the set: {I4, S4.1, S4.2, L4.1, L4.2, L4.3}.

Symbol:

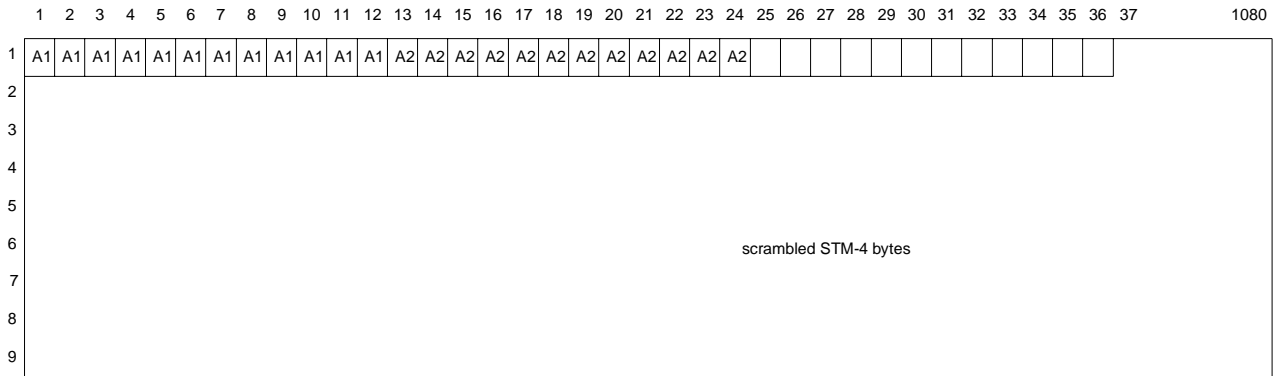

Figure 10: OS4-Xy.z_TT_Sk symbol

Interfaces:

Table 6: OS4-Xy.z_TT_Sk input and output signals

Input(s)	Output(s)
OS4_CI_D	OS4_AI_D
	OS4_AI_TSF
OS4_TT_Sk_MI_PortMode	OS4_TT_Sk_MI_cLOS

Processes:

This function recovers the optical STM-4 signal transmitted over the optical cables. The physical characteristics of the interface signal are defined in ETS 300 232 [6].

The function shall convert the received STM-4 signal, normally complying to the Xy.z characteristics defined in ETS 300 232 [6], into the internal OS4_AI signal.

Port Mode: The function shall have a port mode as specified by subclause 8.5 of EN 300 417-1-1 [8].

NOTE 2: The AUTO state of the port mode process is optional.

Defects:

The function shall detect Loss Of Signal defect (dLOS) according the optical STM-4 dLOS specification in subclause 8.2.1.6 of EN 300 417-1-1 [8].

Consequent Actions:

aTSF ← dLOS.

Defect Correlations:

cLOS ← MON and dLOS.

Performance Monitoring: None.

5.3 Optical Section Adaptation functions

5.3.1 Optical Section to Regenerator Section Adaptation Source OS4/RS4_A_So

Symbol:

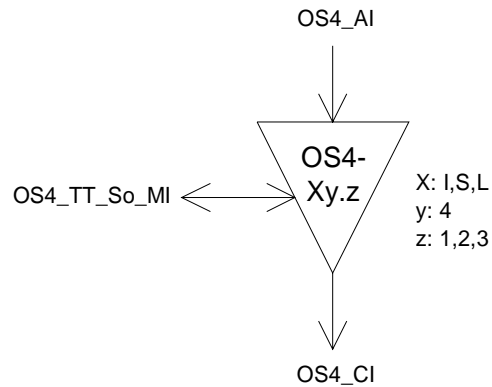

Figure 11: OS4/RS4_A_So symbol

Interfaces:

Table 7: OS4/RS4_A_So input and output signals

Input(s)	Output(s)
RS4_CI_D RS4_CI_CK	OS4_AI_D

Processes: None.

The function shall not add any jitter.

NOTE: Jitter at the NNI is the combination of the jitter generated and transferred via the client layers.

Defects: None.

Consequent Actions: None.

Defect Correlations: None.

Performance Monitoring: None.

5.3.2 Optical Section to Regenerator Section Adaptation Sink OS4/RS4_A_Sk

Symbol:

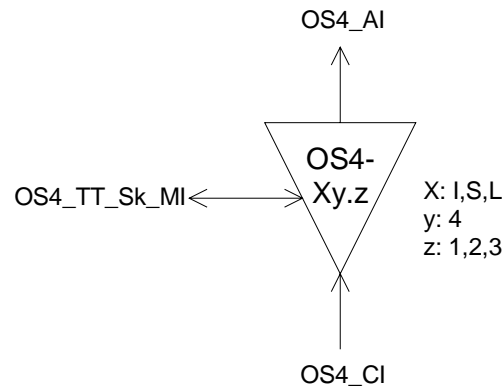

Figure 12: OS4/RS4_A_Sk symbol

Interfaces:

Table 8: OS4/RS4_A_Sk input and output signals

Input(s)	Output(s)
OS4_AI_D OS4_AI_TSF	RS4_CI_D RS4_CI_CK RS4_CI_FS RS4_CI_SSF OS4/RS4_A_Sk_MI_cLOF

Processes:

This function regenerates the received signal, recovers bit timing (CK) and Frame Start reference (FS) from the received signal.

Regeneration: The function shall operate with a maximum BER as specified in EN 300 417-1-1 [8], subclause 11.3.2.1 when any combination of the following signal conditions exist at the input:

- any input optical power level within the range specified in ETS 300 232 [6];
- jitter modulation applied to the input signals specified in EN 300 417-1-1 [8], subclause 11.3.2.1;
- the input signal bit rate has any value in the range 622 080 kbit/s \pm 20 ppm.

NOTE: The frequency and jitter / wander tolerance might be further constrained by the requirements of the client layers.

To ensure adequate immunity against the presence of Consecutive Identical Digits (CID) in the STM-4 signal, the function shall comply with the specification in EN 300 417-1-1 [8], subclause 11.3.2.4.

The function shall process the signal such that in the absence of input jitter, the intrinsic jitter at the STM-4 output interface (in a regenerative repeater) shall not exceed:

- 0,5 UI peak-to-peak when measured through a bandpass filter with corner frequencies at 1 000 Hz and 5 MHz and low pass roll off of 60 dB / decade and high pass roll off of 20 dB / decade;
- 0,1 UI peak-to-peak when measured through a bandpass filter with corner frequencies at 250 kHz and 5 MHz and low pass roll off of 60 dB / decade and high pass roll off of 20 dB / decade.

NOTE: 1 UI = 1,61 ns

The function shall process the signal such that the jitter transfer (measured between an STM-4 input and STM-4 output in a regenerative repeater) shall be as specified in subclause 11.3.3.1 of EN 300 417-1-1 [8].

Frame alignment: The frame alignment shall be performed as specified in subclause 8.2.1.8 of EN 300 417-1-1 [8].

Defects:

The function shall detect for dLOF according the specification in subclause 8.2.1.8 of EN 300 417-1-1 [8].

Consequent Actions:

aAIS ← dLOF or AI_TSF;

aSSF ← dLOF or AI_TSF.

On declaration of an aAIS the function shall output an all-ONES AIS signal - complying to the frequency limits for this interface - within 250 µs; on clearing of aAIS the function shall output normal data within 250 µs.

Defect Correlations:

cLOF ← dLOF and (not AI_TSF).

Performance Monitoring: None.

6 STM-16 Optical Section Layer Functions

NOTE: Xy.z will be one value out of the set: {I16, S16.1, S16.2, L16.1, L16.2, L16.3}.

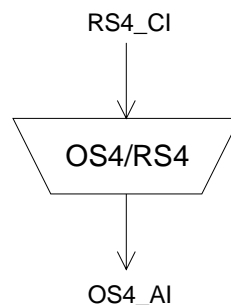

Figure 13: STM-16 Optical Section atomic functions

STM-16 Optical Section Layer CP

Characteristic Information OS16_CI of the optical layer CP (see figure 14) is a digital, optical signal of defined power, bit rate, pulse width and wavelength. A range of such characteristic signals for different optical power budgets is defined in ETS 300 232 [6].

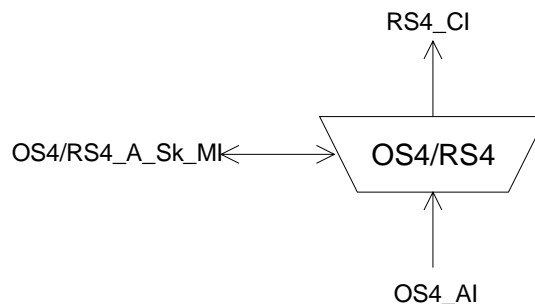

Figure 14: OS16 characteristic information OS16_CI (optical) and adapted information OS16_AI (electrical)

STM-16 Optical Section Layer AP

The information passing across the OS16 AP takes the form of a scrambled, digital bitstream (including a block frame character at 125 μ s intervals) with co-directional bit timing (see figure 14). Frame characters and the synchronous, scrambling polynomial are defined in ETS 300 147 [3].

6.1 Optical Section Connection functions

For further study.

6.2 Optical Section Trail Termination functions

6.2.1 Optical Section Trail Termination Source OS16-Xy.z_TT_So

NOTE: Xy.z will be one value out of the set: {I16, S16.1, S16.2, L16.1, L16.2, L16.3}.

Symbol:

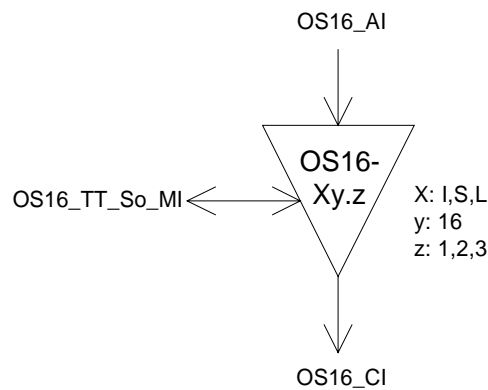

Figure 15: OS16-Xy.z_TT_So symbol

Interfaces:

Table 9: OS16_TT_So input and output signals

Input(s)	Output(s)
OS16_AI_D	OS16_CI_D

Processes:

This function forms the optical STM-16 signal for transmission over the optical cable as defined in ETS 300 232 [6].

Optical characteristics: The function shall generate an optical STM-16 signal that meets the Xy.z characteristics defined in ETS 300 232 [6].

Defects: None.

Consequent Actions: None.

Defect Correlations: None.

Performance Monitoring: None.

6.2.2 Optical Section Trail Termination Sink OS16-Xy.z_TT_Sk

NOTE 1: Xy.z will be one value out of the set: {I16, S16.1, S16.2, L16.1, L16.2, L16.3}.

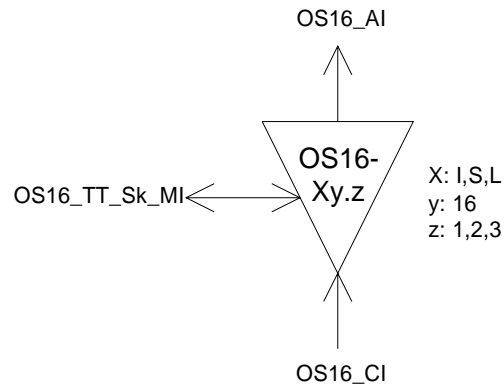
Symbol:**Figure 16: OS16-Xy.z_TT_Sk symbol****Interfaces:****Table 10: OS16_TT_Sk input and output signals**

Input(s)	Output(s)
OS16_CI_D	OS16_AI_D
	OS16_AI_TSF
OS16_TT_Sk_MI_PortMode	OS16_TT_Sk_MI_cLOS

Processes:

This function recovers the optical STM-16 signal transmitted over the optical cables. The physical characteristics of the interface signal are defined in ETS 300 232 [6].

The function shall convert the received STM-16 signal, normally complying to the Xy.z characteristics defined in ETS 300 232 [6], into the internal OS16_AI signal.

Port Mode: The function shall have a port mode as specified by subclause 8.5 of EN 300 417-1-1 [8].

NOTE 2: The AUTO state of the port mode process is optional.

Defects:

The function shall detect Loss Of Signal defect (dLOS) according the optical STM-16 dLOS specification in subclause 8.2.1.6 of EN 300 417-1-1 [8].

Consequent Actions:

aTSF ← dLOS.

Defect Correlations:

cLOS ← MON and dLOS.

Performance Monitoring: None.

6.3 Optical Section Adaptation functions

6.3.1 Optical Section to Regenerator Section Adaptation Source OS16/RS16_A_So

Symbol:

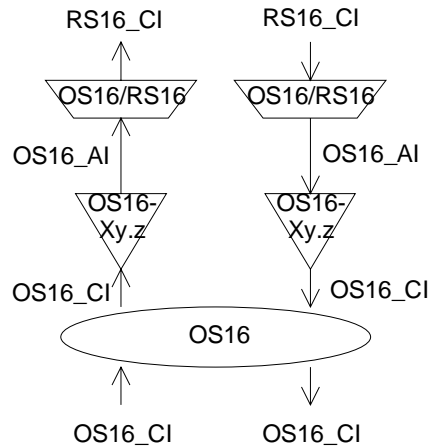

Figure 17: OS16/RS16_A_So symbol

Interfaces:

Table 11: OS16/RS16_A_So input and output signals

Input(s)	Output(s)
RS16_CI_D RS16_CI_CK	OS16_AI_D

Processes:

The function shall not add any jitter.

NOTE: Jitter at the NNI is the combination of the jitter generated and transferred via the client layers.

Defects: None.

Consequent Actions: None.

Defect Correlations: None.

Performance Monitoring: None.

6.3.2 Optical Section to Regenerator Section Adaptation Sink OS16/RS16_A_Sk

Symbol:

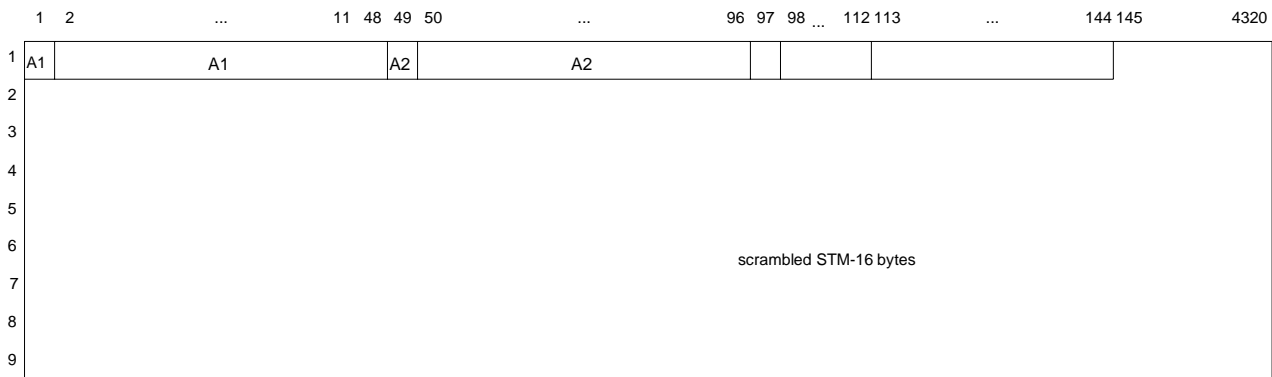

Figure 18: OS16/RS16_A_Sk symbol

Interfaces:

Table 12: OS16/RS16_A_Sk input and output signals

Input(s)	Output(s)
OS16_AI_D OS16_AI_TSF	RS16_CI_D RS16_CI_CK RS16_CI_FS RS16_CI_SSF OS16/RS16_A_Sk_MI_cLOF

Processes:

This function regenerates the received signal, recovers bit timing (CK) and Frame Start reference (FS) from the received signal.

Regeneration: The function shall operate with a maximum BER as specified in EN 300 417-1-1 [8], subclause 11.3.2.1 when any combination of the following signal conditions exist at the input:

- any input optical power level within the range specified in ETS 300 232 [6];
- jitter modulation applied to the input signal as specified in EN 300 417-1-1 [8], subclause 11.3.2.1;
- the input signal bit rate has any value in the range $2\,488\,320\text{ kbit/s} \pm 20\text{ ppm}$.

NOTE: The frequency and jitter / wander tolerance might be further constrained by the requirements of the client layers.

To ensure adequate immunity against the presence of Consecutive Identical Digits (CID) in the STM-16 signal, the function shall comply with the specification in EN 300 417-1-1 [8], subclause 11.3.2.4.

The function shall process the signal such that in the absence of input jitter, the intrinsic jitter at the STM-16 output interface (in a regenerative repeater) shall not exceed:

- 0,3 UI peak-to-peak when measured through a bandpass filter with corner frequencies at 5 000 Hz and 20 MHz and low pass roll off of 60 dB / decade and high pass roll off of 20 dB / decade;
- 0,1 UI peak-to-peak when measured through a bandpass filter with corner frequencies at 1 MHz and 20 MHz and low pass roll off of 60 dB / decade and high pass roll off of 20 dB / decade.

NOTE: 1 UI = 402 ps

The function shall process the signal such that the jitter transfer (measured between an STM-16 input and STM-16 output in a regenerative repeater) shall be as specified in subclause 11.3.3.1 of EN 300 417-1-1 [8].

Frame alignment: The frame alignment shall be performed as specified in subclause 8.2.1.8 of EN 300 417-1-1 [8].

Defects:

The function shall detect for dLOF according the specification in subclause 8.2.1.8 of EN 300 417-1-1 [8].

Consequent Actions:

aAIS ← dLOF or AI_TSF;

aSSF ← dLOF or AI_TSF.

On declaration of an aAIS the function shall output an all-ONES (AIS) signal - complying to the frequency limits for this interface - within 250 µs; on clearing of aAIS the function shall output normal data within 250 µs.

Defect Correlations:

cLOF ← dLOF and (not AI_TSF).

Performance Monitoring: None.

7 STM-64 Optical Section Layer Functions

NOTE: Xy.z will be one value out of the set: {S64.1, S64.2, S64.3, L64.1, L64.2, L64.3}.

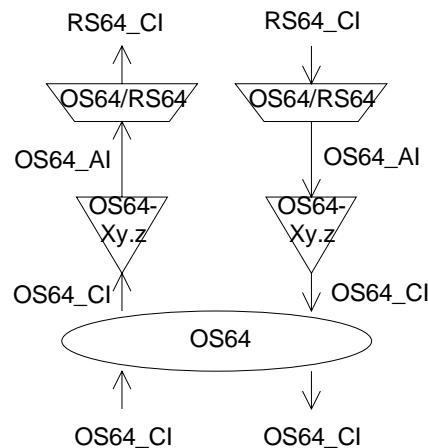

Figure 19: STM-64 Optical Section atomic functions

STM-64 Optical Section Layer CP

Characteristic Information OS64_CI of the optical layer CP (see figure 20) is a digital, optical signal of defined power, bit rate, pulse width and wavelength. A range of such characteristic signals for different optical power budgets is defined in ITU-T Recommendation G.691 [18].

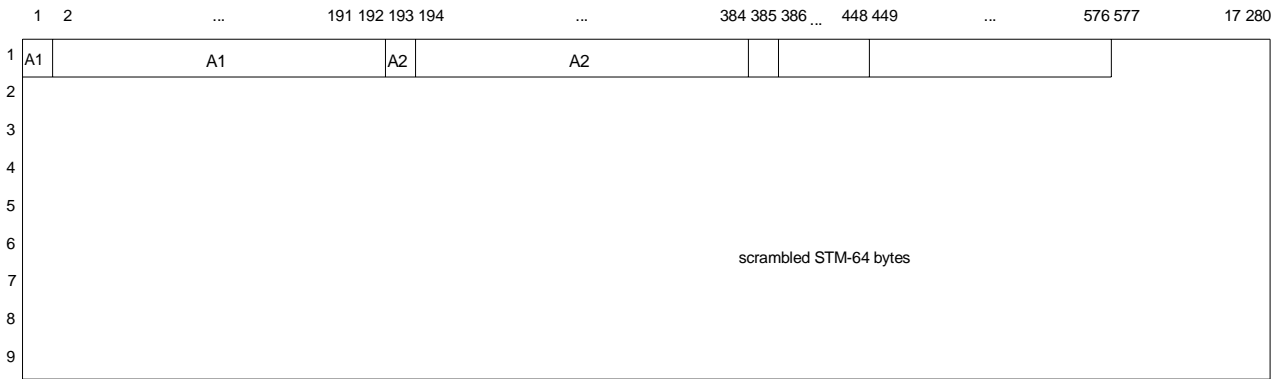

Figure 20: OS64 characteristic information OS64_CI (optical) and adapted information OS64_AI (electrical)

STM-64 Optical Section Layer AP

The information passing across the OS64 AP takes the form of a scrambled, digital bitstream (including a block frame character at 125 μs intervals) with co-directional bit timing (see figure 20). Frame characters and the synchronous, scrambling polynomial are defined in ITU-T Recommendation G.691 [18].

7.1 Optical Section Connection functions

For further study.

7.2 Optical Section Trail Termination functions

7.2.1 Optical Section Trail Termination Source OS64-Xy.z_TT_So

NOTE: Xy.z will be one value out of the set: {S64.1, S64.2, S64.3, L64.1, L64.2, L64.3}.

Symbol:

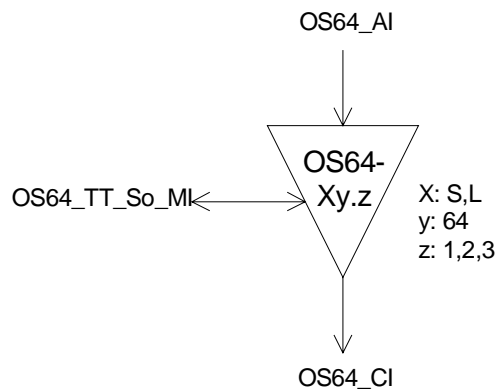

Figure 21: OS64-Xy.z_TT_So symbol

Interfaces:

Table 13: OS64_TT_So input and output signals

Input(s)	Output(s)
OS64_AI_D	OS64_CI_D

Processes:

This function forms the optical STM-64 signal for transmission over the optical cable as defined in ITU-T Recommendation G.691 [18].

Optical characteristics: The function shall generate an optical STM-64 signal that meets the Xy.z characteristics defined in ITU-T Recommendation G.691 [18].

Defects: None.

Consequent Actions: None.

Defect Correlations: None.

Performance Monitoring: None.

7.2.2 Optical Section Trail Termination Sink OS64-Xy.z_TT_Sk

NOTE 1: Xy.z will be one value out of the set: {S64.1, S64.2, S64.3, L64.1, L64.2, L64.3}.

Symbol:

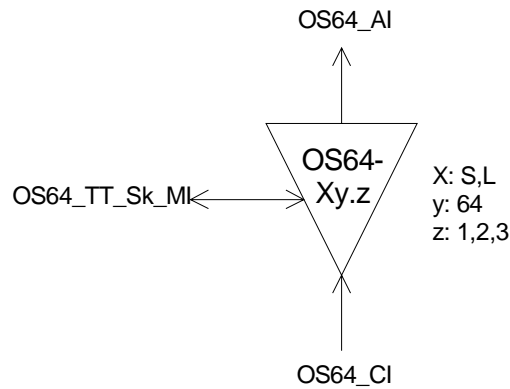

Figure 22: OS64-Xy.z_TT_Sk symbol

Interfaces:

Table 14: OS64_TT_Sk input and output signals

Input(s)	Output(s)
OS64_CI_D	OS64_AI_D
	OS64_AI_TSF
OS64_TT_Sk_MI_PortMode	OS64_TT_Sk_MI_cLOS

Processes:

This function recovers the optical STM-64 signal transmitted over the optical cables. The physical characteristics of the interface signal are defined in ITU-T Recommendation G.691 [18].

The function shall convert the received STM-64 signal, normally complying to the Xy.z characteristics defined in ITU-T Recommendation G.691 [18], into the internal OS64_AI signal.

Port Mode: The function shall have a port mode as specified by subclause 8.5 of EN 300 417-1-1 [8].

NOTE 2: The AUTO state of the port mode process is optional.

Defects:

The function shall detect Loss Of Signal defect (dLOS) according the optical STM-64 dLOS specification in subclause 8.2.1.6 of EN 300 417-1-1 [8].

Consequent Actions:

aTSF ← dLOS.

Defect Correlations:

cLOS ← MON and dLOS.

Performance Monitoring: None.

7.3 Optical Section Adaptation functions

7.3.1 Optical Section to Regenerator Section Adaptation Source OS64/RS64_A_So

Symbol:

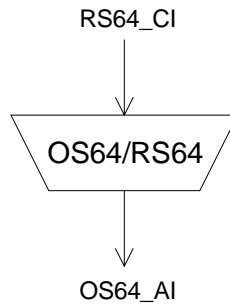

Figure 23: OS64/RS64_A_So symbol

Interfaces:

Table 15: OS64/RS64_A_So input and output signals

Input(s)	Output(s)
RS64_CI_D RS64_CI_CK	OS64_AI_D

Processes:

The function shall not add any jitter.

NOTE: Jitter at the NNI is the combination of the jitter generated and transferred via the client layers.

Defects:	None.
Consequent Actions:	None.
Defect Correlations:	None.
Performance Monitoring:	None.

7.3.2 Optical Section to Regenerator Section Adaptation Sink OS64/RS64_A_Sk

Symbol:

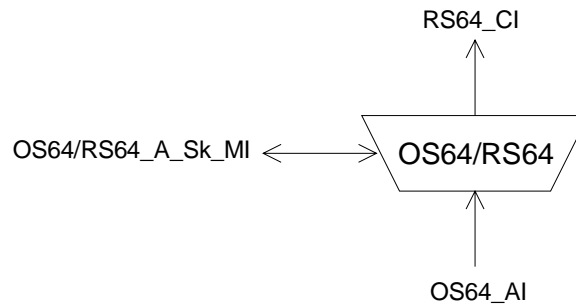

Figure 24: OS64/RS64_A_Sk symbol

Interfaces:

Table 16: OS64/RS64_A_Sk input and output signals

Input(s)	Output(s)
OS64_AI_D OS64_AI_TSF	RS64_CI_D RS64_CI_CK RS64_CI_FS RS64_CI_SSF OS64/RS64_A_Sk_MI_cLOF

Processes:

This function regenerates the received signal, recovers bit timing (CK) and Frame Start reference (FS) from the received signal.

Regeneration: The function shall operate with a maximum BER as specified in EN 300 417-1-1 [8], subclause 11.3.2.1 when any combination of the following signal conditions exist at the input:

- any input optical power level within the range specified in ITU-T Recommendation G.691 [18];
- jitter modulation applied to the input signal as specified in EN 300 417-1-1 [8], subclause 11.3.2.1;
- the input signal bit rate has any value in the range 9 953 280 kbit/s \pm 20 ppm.

NOTE: The frequency and jitter / wander tolerance might be further constrained by the requirements of the client layers.

To ensure adequate immunity against the presence of Consecutive Identical Digits (CID) in the STM-64 signal, the function shall comply with the specification in EN 300 417-1-1 [8], subclause 11.3.2.4.

The function shall process the signal such that in the absence of input jitter, the intrinsic jitter at the STM-64 output interface (in a regenerative repeater) shall not exceed:

- 0,3 UI peak-to-peak when measured through a bandpass filter with corner frequencies at 20 000 Hz and 80 MHz and low pass roll off of 60 dB / decade and high pass roll off of 20 dB / decade;

- 0,1 UI peak-to-peak when measured through a bandpass filter with corner frequencies at 4 MHz and 80 MHz and low pass roll off of 60 dB / decade and high pass roll off of 20 dB / decade.

NOTE: 1 UI = 100 ps

The function shall process the signal such that the jitter transfer (measured between an STM-64 input and STM-64 output in a regenerative repeater) shall be as specified in subclause 11.3.3.1 of EN 300 417-1-1 [8].

Frame alignment: The frame alignment shall be performed as specified in subclause 8.2.1.8 of EN 300 417-1-1 [8].

Defects:

The function shall detect for dLOF according the specification in subclause 8.2.1.8 of EN 300 417-1-1 [8].

Consequent Actions:

aAIS ← dLOF or AI_TSF;

aSSF ← dLOF or AI_TSF.

On declaration of an aAIS the function shall output an all-ONES (AIS) signal - complying to the frequency limits for this interface - within 250 μs; on clearing of aAIS the function shall output normal data within 250 μs.

Defect Correlations:

cLOF ← dLOF and (not AI_TSF).

Performance Monitoring:

None.

8 STM-256 Optical Section Layer Functions

NOTE: Xy.z will be one value out of the set: {for further study}.

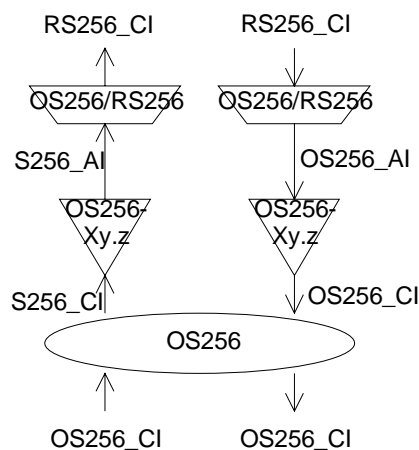

Figure 25: STM-256 Optical Section atomic functions

STM-256 Optical Section Layer CP

Characteristic Information OS256_CI of the optical layer CP (see figure 26) is a digital, optical signal of defined power, bit rate, pulse width and wavelength. A range of such characteristic signals for different optical power budgets is defined in ITU-T Recommendation for further standardization.

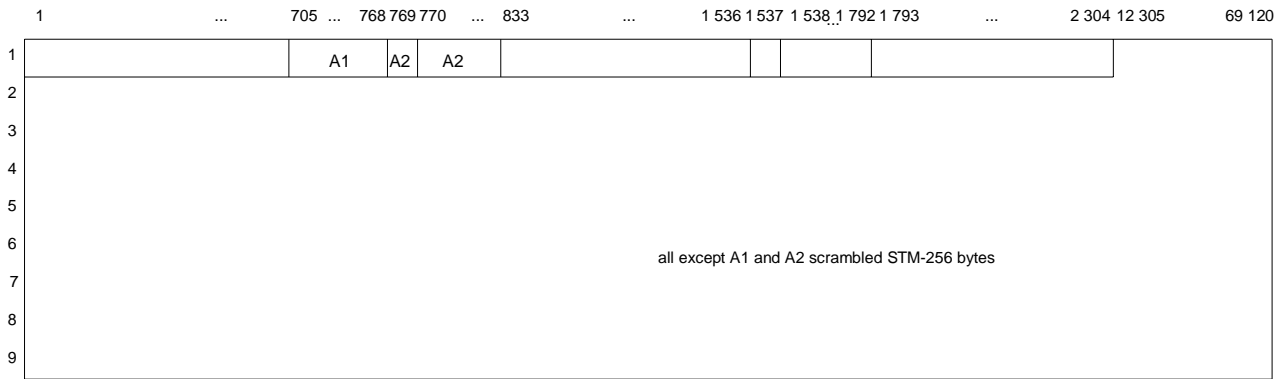

Figure 26: OS256 characteristic information OS256_CI (optical) and adapted information OS256_AI (electrical)

STM-256 Optical Section Layer AP

The information passing across the OS256 AP takes the form of a scrambled, digital bitstream (including a block frame character at 125 μs intervals) with co-directional bit timing (see figure 26). Frame characters and the synchronous, scrambling polynomial are defined in ETS 300 147 [3].

8.1 Optical Section Connection functions

For further study.

8.2 Optical Section Trail Termination functions

8.2.1 Optical Section Trail Termination Source OS256-Xy.z_TT_So

NOTE: Xy.z will be one value out of the set: {for further study}.

Symbol:

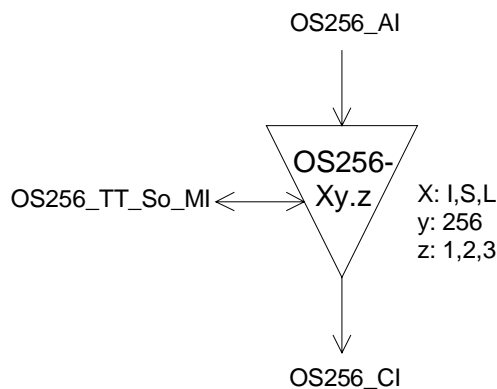

Figure 27: OS256-Xy.z_TT_So symbol

Interfaces:

Table 17: OS256_TT_So input and output signals

Input(s)	Output(s)
OS256_AI_D	OS256_CI_D

Processes:

This function forms the optical STM-256 signal for transmission over the optical cable as defined in ITU-T Recommendation for further standardization.

Optical characteristics: The function shall generate an optical STM-256 signal that meets the Xy.z characteristics defined in ITU-T Recommendation for further standardization.

Defects:: None.

Consequent Actions: None.

Defect Correlations: None.

Performance Monitoring: None.

8.2.2 Optical Section Trail Termination Sink OS256-Xy.z_TT_Sk

NOTE 1: Xy.z will be one value out of the set: {for further study}.

Symbol:

Figure 28: OS256-Xy.z_TT_Sk symbol

Interfaces:

Table 18: OS256_TT_Sk input and output signals

Input(s)	Output(s)
OS256_CI_D	OS256_AI_D OS256_AI_TSF
OS256_TT_Sk_MI_PortMode	OS256_TT_Sk_MI_cLOS

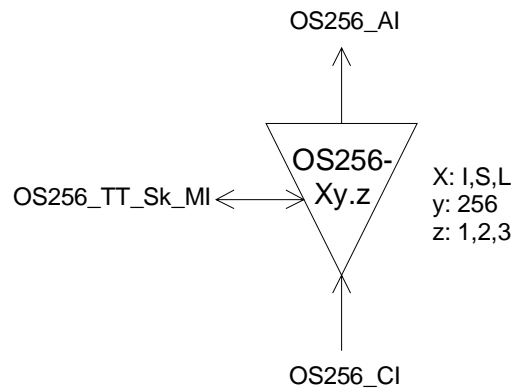
Processes:

This function recovers the optical STM-256 signal transmitted over the optical cables. The physical characteristics of the interface signal are defined in ITU-T Recommendation for further standardization.

The function shall convert the received STM-256 signal, normally complying to the Xy.z characteristics defined in ITU-T Recommendation for further standardization, into the internal OS256_AI signal.

Port Mode: The function shall have a port mode as specified by subclause 8.5 of EN 300 417-1-1 [8].

NOTE 2: The AUTO state of the port mode process is optional.

Defects:

The function shall detect Loss Of Signal defect (dLOS) according the optical STM-256 dLOS specification in subclause 8.2.1.6 of EN 300 417-1-1 [8].

Consequent Actions:

aTSF ← dLOS.

Defect Correlations:

cLOS ← MON and dLOS.

Performance Monitoring: None.

8.3 Optical Section Adaptation functions

8.3.1 Optical Section to Regenerator Section Adaptation Source OS256/RS256_A_So

Symbol:

Figure 29: OS256/RS256_A_So symbol

Interfaces:

Table 19: OS256/RS256_A_So input and output signals

Input(s)	Output(s)
RS256_CI_D RS256_CI_CK	OS256_AI_D

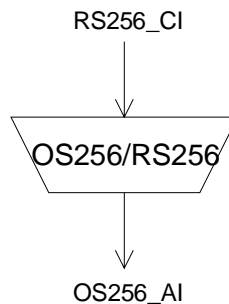
Processes:

The function shall not add any jitter.

NOTE: Jitter at the NNI is the combination of the jitter generated and transferred via the client layers.

Defects:	None.
Consequent Actions:	None.
Defect Correlations:	None.
Performance Monitoring:	None.

8.3.2 Optical Section to Regenerator Section Adaptation Sink OS256/RS256_A_Sk

Symbol:

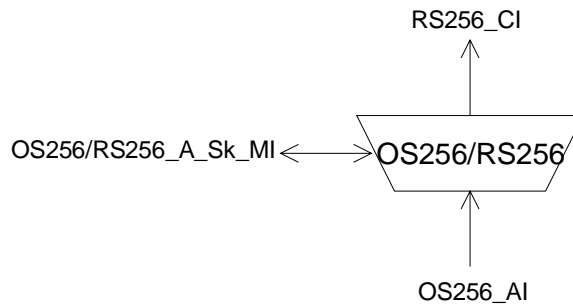

Figure 30: OS256/RS256_A_Sk symbol

Interfaces:

Table 20: OS256/RS256_A_Sk input and output signals

Input(s)	Output(s)
OS256_AI_D OS256_AI_TSF	RS256_CI_D RS256_CI_CK RS256_CI_FS RS256_CI_SSF OS256/RS256_A_Sk_MI_cLOF

Processes:

This function regenerates the received signal, recovers bit timing (CK) and Frame Start reference (FS) from the received signal.

Regeneration: The function shall operate with a maximum BER as specified in EN 300 417-1-1 [8], subclause 11.3.2.1 when any combination of the following signal conditions exist at the input:

- any input optical power level within the range specified in ITU-T Recommendation for further standardization;
- jitter modulation applied to the input signal as specified in EN 300 417-1-1 [8], subclause 11.3.2.1;
- the input signal bit rate has any value in the range $39\ 813\ 120\ \text{kb/s} \pm 20\ \text{ppm}$.

NOTE: The frequency and jitter / wander tolerance might be further constrained by the requirements of the client layers.

To ensure adequate immunity against the presence of Consecutive Identical Digits (CID) in the STM-256 signal, the function shall comply with the specification in EN 300 417-1-1 [8], subclause 11.3.2.4.

The function shall process the signal such that in the absence of input jitter, the intrinsic jitter at the STM-256 output interface (in a regenerative repeater) shall not exceed:

- 0,3 UI peak-to-peak when measured through a bandpass filter with corner frequencies at 80 000 Hz and 320 MHz and low pass roll off of 60 dB / decade and high pass roll off of 20 dB / decade;

- 0,1 UI peak-to-peak when measured through a bandpass filter with corner frequencies at 16 MHz and 320 MHz and low pass roll off of 60 dB / decade and high pass roll off of 20 dB / decade.

NOTE: 1 UI = 25 ps

The function shall process the signal such that the jitter transfer (measured between an STM-256 input and STM-256 output in a regenerative repeater) shall be as specified in subclause 11.3.3.1 of EN 300 417-1-1 [8].

Frame alignment: The frame alignment shall be performed as specified in subclause 8.2.1.8 of EN 300 417-1-1 [8].

Defects:

The function shall detect for dLOF according the specification in subclause 8.2.1.8 of EN 300 417-1-1 [8].

Consequent Actions:

aAIS ← dLOF or AI_TSF;

aSSF ← dLOF or AI_TSF.

On declaration of an aAIS the function shall output an all-ONES (AIS) signal - complying to the frequency limits for this interface - within 250 μs; on clearing of aAIS the function shall output normal data within 250 μs.

Defect Correlations:

cLOF ← dLOF and (not AI_TSF).

Performance Monitoring: None.

9 STM-1 Electrical Section Layer Functions

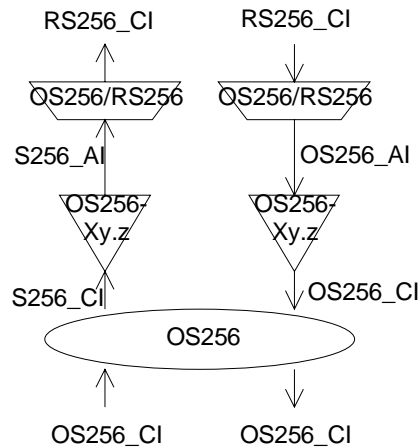

Figure 31: STM-1 Electrical Section atomic functions

STM-1 Electrical Section layer CP

The Characteristic Information ES1_CI of the intra-station electrical STM-1 layer CP (see figure 32) is a digital, CMI encoded, electrical signal of defined amplitude, bit rate and pulse shape as defined in ETS 300 166 [4].

NOTE: Characteristic information for a STM-1 UNI is for further study.

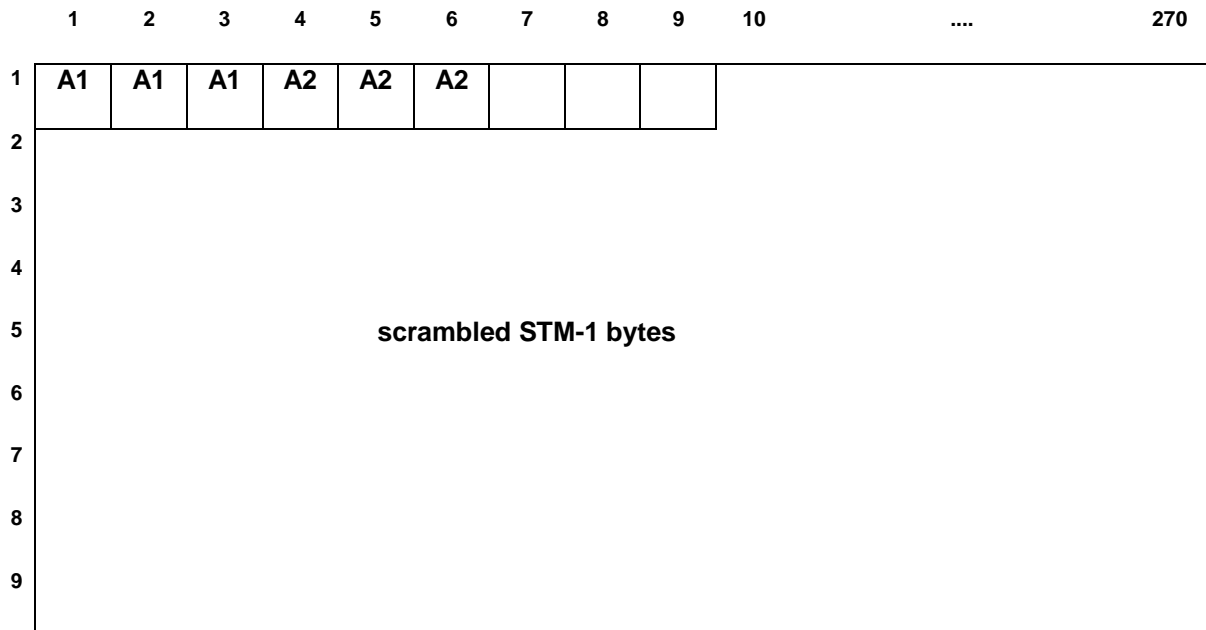

Figure 32: ES1 characteristic and adaptation information ES1_CI and ES1_AI

STM-1 Electrical Section layer AP

The information passing across the STM-1 ES AP takes the form of a scrambled, digital bitstream (including a block frame character at 125 μs intervals) with co-directional bit timing (see figure 32). Frame characters and the synchronous, scrambling polynomial is defined in ETS 300 147 [3].

9.1 STM-1 Electrical Section Connection function ES1_C

For further study.

9.2 STM-1 Electrical Section Trail Termination functions

9.2.1 STM-1 Electrical Section Trail Termination Source ES1_TT_So

Symbol:

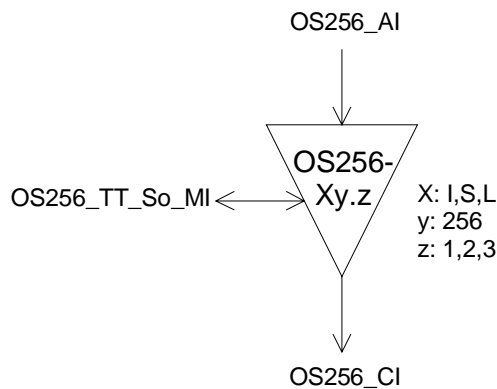

Figure 33: ES1_TT_So symbol

Interfaces:

Table 21: ES1_TT_So input and output signals

Input(s)	Output(s)
ES1_AI_D	ES1_CI_D

Processes:

This function generates the STM-1 electrical Intra-station Section Layer signal as specified by ETS 300 166 [4].

Pulse shape: The function shall meet the requirement specified by ETS 300 166 [4].

Peak to peak voltage: The function shall meet the requirement specified by ETS 300 166 [4].

Rise time: The function shall meet the requirement specified by ETS 300 166 [4].

Pair(s) in each direction: The function shall meet the requirement specified by ETS 300 166 [4].

Output return loss: The function shall meet the requirement specified by ETS 300 166 [4].

Defects: None.

Consequent Actions: None.

Defect Correlations: None.

Performance Monitoring: None.

9.2.2 STM-1 Electrical Section Trail Termination Sink ES1_TT_Sk

Symbol:

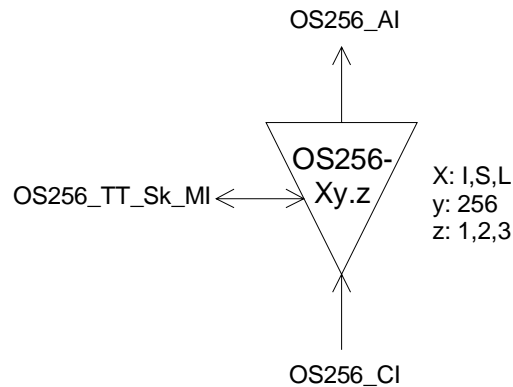

Figure 34: ES1_TT_Sk symbol

Interfaces:

Table 22: ES1_TT_Sk input and output signals

Input(s)	Output(s)
ES1_CI_D	ES1_AI_D
	ES1_AI_TSF
ES1_TT_Sk_MI_PortMode	ES1_TT_Sk_MI_cLOS

Processes:

This function recovers the electrical STM-1 Intra-station Section Layer signal as defined in ETS 300 166 [4].

Input return loss: The function shall meet the requirement specified by ETS 300 166 [4].

Port Mode: The function shall have a port mode as specified by subclause 8.5 of EN 300 417-1-1 [8].

NOTE: The AUTO state of the port mode process is optional.

Defects:

The function shall detect Loss Of Signal defect (dLOS) according the electrical STM-1 dLOS specification in subclause 8.2.1.6 of EN 300 417-1-1 [8].

Consequent Actions:

aTSF ← dLOS.

Defect Correlations:

cLOS ← MON and dLOS.

Performance Monitoring: None.

9.3 STM-1 Electrical Section Adaptation functions

9.3.1 STM-1 Electrical Section to Regenerator Section Adaptation Source ES1/RS1_A_So

Symbol:

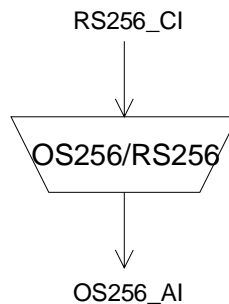

Figure 35: ES1/RS1_A_So symbol

Interfaces:

Table 23: ES1/RS1_A_So input and output signals

Input(s)	Output(s)
RS1_CI_D RS1_CI_CK	ES1_AI_D

Processes:

This function provides CMI encoding of the STM-1 signal.

CMI encoder: The function shall perform CMI encoding of the data specified by ETS 300 166 [4].

The CMI encoding process in the function shall process the signal such that in the absence of input jitter at the synchronization interface, the intrinsic jitter at the STM-1 output interface as measured over a 60 seconds interval shall not exceed:

- 0,5 UI peak-peak when measured through a band-pass filter with corner frequencies at 500 Hz and 1,3 MHz and low pass roll off of 60 dB / decade and high pass roll off of 20 dB / decade;
- 0,075 UI peak-peak when measured through a band-pass filter with corner frequencies at 65 kHz and 1,3 MHz and low pass roll off of 60 dB / decade and high pass roll off of 20 dB / decade.

NOTE: 1 UI = 6,43 ns

Consequent Actions: None.

Defect Correlations: None.

Performance Monitoring: None.

9.3.2 STM-1 Electrical Section to Regenerator Section Adaptation Sink ES1/RS1_A_Sk

Symbol:

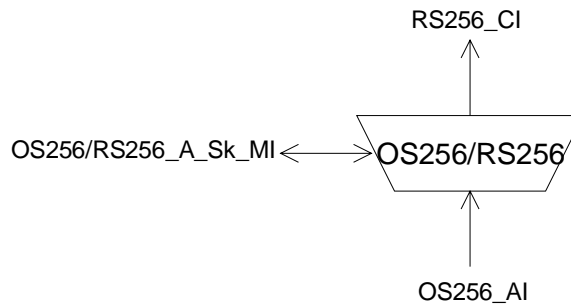

Figure 36: ES1/RS1_A_Sk symbol

Interfaces:

Table 24: ES1/RS1_A_Sk input and output signals

Input(s)	Output(s)
ES1_AI_D ES1_AI_TSF	RS1_CI_D RS1_CI_CK RS1_CI_FS RS1_CI_SSF ES1/RS1_A_Sk_MI_cLOF

Processes:

This function regenerates the received signal, recovers bit timing (CK) and Frame Start reference (FS) from the received signal, and decodes the incoming STM-1 signal.

Regeneration: The function shall operate without any errors when any combination of the following signal conditions exist at the input:

- an input electrical amplitude level with any value specified by ETS 300 166 [4];
- jitter modulation applied to the input signal with any value defined in ITU-T Recommendation G.825 [16];
- the input signal bit rate has any value in the range 155 520 kbit/s \pm 20 ppm.

NOTE: The frequency and jitter / wander tolerance might be further constrained by the requirements of the client layers.

CMI decoding: The function shall perform the CMI decoding process specified by ETS 300 166 [4].

Frame alignment: The frame alignment shall be performed as specified in subclause 8.2.1.8 of EN 300 417-1-1 [8].

Defects:

The function shall detect for dLOF according the specification in subclause 8.2.1.8 of EN 300 417-1-1 [8].

Consequent Actions:

aAIS ← dLOF or AI_TSF.

aSSF ← dLOF or AI_TSF.

On declaration of aAIS the function shall output an all-ONEs (AIS) signal - complying to the frequency limits for this interface - within 250 µs; on clearing of aAIS the function shall output normal data within 250 µs.

Defect Correlations:

cLOF ← dLOF and (not AI_TSF).

Performance Monitoring: None.

10 E4 Section Layer Functions

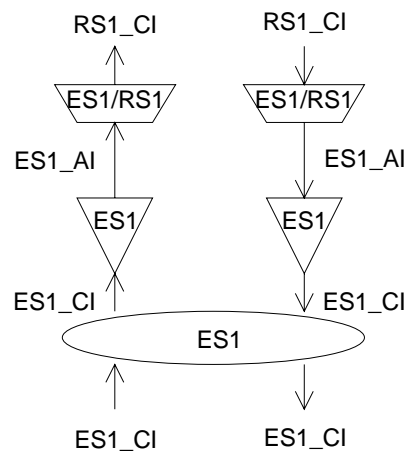

Figure 37: E4 Section atomic functions

E4 layer CP

The Characteristic Information E4_CI on the intra-station electrical layer CP is a digital, CMI encoded, electrical signal of defined amplitude, bit rate and pulse shape as defined in ETS 300 166 [4].

E4 layer AP

The information passing across the E4/P4x AP is a plesiochronous 139 264 kbit/s signal of non-specified content with co-directional bit timing.

The information passing across the E4/P4e AP is a 139 264 kbit/s signal with co-directional bit timing specified by CCITT Recommendation G.751 [13]. It contains four 34 368 kbit/s tributary signals (see figure 38).

Figure 37 shows that more than one adaptation function exists in this E4 layer that can be connected to one E4 access point. For the case of the adaptation source functions, only one of these adaptation source functions is allowed to be activated. For this activated source, access to the access point by other adaptation source functions shall be denied. In contradiction with the source direction, adaptation sink functions may be activated all together. This may cause faults (e.g. cLOF) to be detected and reported. To prevent this an adaptation sink function can be deactivated.

NOTE: If one adaptation function only is connected to the AP, it will be activated. If one or more other functions are connected to the same AP, one out of the set of functions will be active.

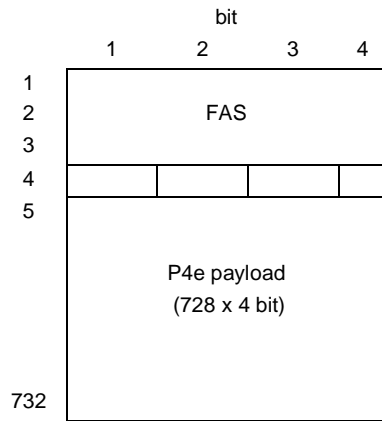

Figure 38: Decoded E4/P4e_AI_D signal

The information passing across the E4/P4s AP is a 139 264 kbit/s signal with co-directional bit timing specified by ETS 300 337 [7] (see figure 39).

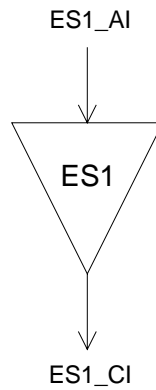

Figure 39: Decoded E4/P4s_AI_D signal

10.1 E4 Connection function E4_C

For further study.

10.2 E4 Trail Termination functions

10.2.1 E4 Trail Termination Source E4_TT_So

Symbol:

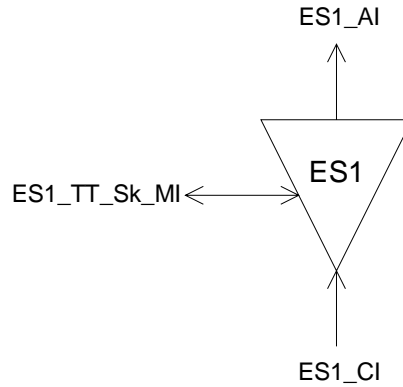

Figure 40: E4_TT_So symbol

Interfaces:

Table 25: E4_TT_So input and output signals

Input(s)	Output(s)
E4_AI_D	E4_CI_D

Processes:

This function generates the electrical Intra-station Section Layer signal E4 specified by ETS 300 166 [4].

Pulse shape: The function shall meet the requirement specified by ETS 300 166 [4].

Peak to Peak Voltage: The function shall meet the requirement specified by ETS 300 166 [4].

Rise time: The function shall meet the requirement specified by ETS 300 166 [4].

Pair(s) in each direction: The function shall meet the requirement specified by ETS 300 166 [4].

Output return loss: The function shall meet the requirement specified by ETS 300 166 [4].

Defects: None.

Consequent Actions: None.

Defect Correlations: None.

Performance Monitoring: None.

10.2.2 E4 Trail Termination Sink E4_TT_Sk

Symbol:

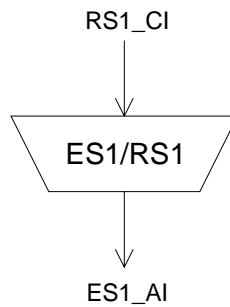

Figure 41: E4_TT_Sk symbol

Interfaces:

Table 26: E4_TT_Sk input and output signals

Input(s)	Output(s)
E4_CI_D	E4_AI_D
E4_TT_Sk_MI_PortMode	E4_AI_TSF
	E4_TT_Sk_MI_cLOS

Processes:

This function recovers the electrical Intra-station Section Layer signal E4 specified by ETS 300 166 [4].

Input return loss: The function shall meet the requirement specified by ETS 300 166 [4].

Port Mode: The function shall have a port mode as specified by subclause 8.5 of EN 300 417 1-1 [8].

NOTE: The AUTO state of the port mode process is optional.

Defects:

The function shall detect Loss Of Signal defect (dLOS) according the 139 264 kbit/s dLOS specification in subclause 8.2.1.6 of EN 300 417-1-1 [8].

Consequent Actions:

aTSF ← dLOS.

Defect Correlations:

cLOS ← MON and dLOS.

Performance Monitoring: None.

10.3 E4 Adaptation functions

10.3.1 E4 to P4x Adaptation Source E4/P4x_A_So

Symbol:

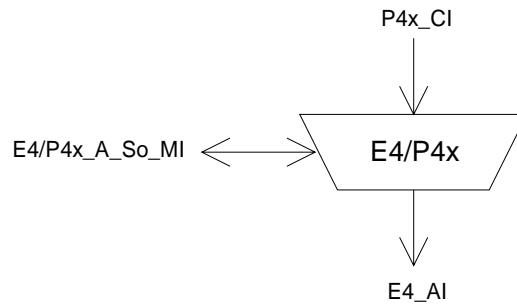

Figure 42: E4/P4x_A_So symbol

Interfaces:

Table 27: E4/P4x_A_So input and output signals

Input(s)	Output(s)
P4x_CI_D P4x_CI_CK E4/P4x_A_So_MI_Active	E4_AI_D

Processes:

This function provides the CMI encoding of the 139 264 kbit/s information stream as defined in ETS 300 166 [4].

CMI encoder: The function shall perform CMI encoding of the data specified by ETS 300 166 [4].

The function shall not add any jitter.

NOTE: Jitter at the NNI is the combination of the jitter generated and transferred via the client layers.

Activation: The function shall access the access point when it is activated (MI_Active is true). Otherwise, it shall not access the access point.

Defects: None.

Consequent Actions: None.

Defect Correlations: None.

Performance Monitoring: None.

10.3.2 E4 to P4x Adaptation Sink E4/P4x_A_Sk

Symbol:

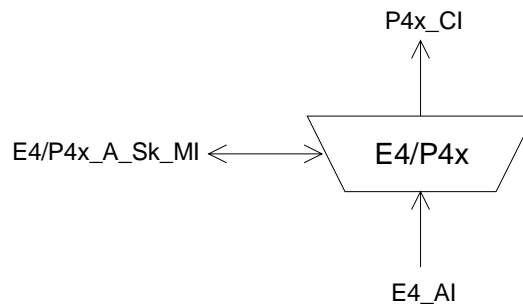

Figure 43: E4/P4x_A_Sk symbol

Interfaces:

Table 28: E4/P4x_A_Sk input and output signals

Input(s)	Output(s)
E4_AI_D	P4x_CI_D
E4_AI_TSF	P4x_CI_CK
E4/P4x_A_Sk_MI_Active	P4x_CI_SSF

Processes:

This function regenerates the received signal, recovers bit timing (CK) from the received signal, and decodes the incoming electrical 139 264 kbit/s E4 signal.

Regeneration: The function shall operate without any errors when any combination of the following signal conditions exist at the input:

- an input electrical amplitude level with any value in the range specified by ETS 300 166 [4];
- jitter modulation applied to the input signal with any value defined in ITU-T Recommendation G.823 [15];
- the input signal bit rate has any value in the range 139 264 kbit/s \pm 15 ppm.

NOTE: The frequency and jitter / wander tolerance might be further constrained by the requirements of the client layers.

CMI decoding: The function shall perform the CMI decoding process specified by ETS 300 166 [4].

Activation: The function shall perform the operation specified above when it is activated (MI_Active is true).

Otherwise, it shall transmit the all-ONES signal at its output (CI_D) and not report its status via the management point.

Defects: None.

Consequent Actions:

aSSF ← AI_TSF.

aAIS ← AI_TSF.

On declaration of aAIS the function shall output an all-ONES (AIS) signal - complying to the frequency limits for this interface - within 250 μ s; on clearing of aAIS the function shall output normal data within 250 μ s.

Defect Correlations: None.

Performance Monitoring: None.

10.3.3 E4 to P4e Adaptation Source E4/P4e_A_So

Symbol:

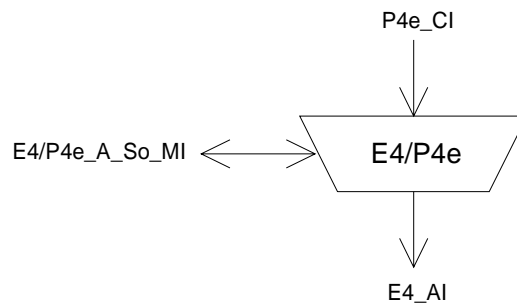

Figure 44: E4/P4e_A_So symbol

Interfaces:

Table 29: E4/P4e_So input and output signals

Input(s)	Output(s)
P4e_CI_D P4e_CI_CK E4/P4e_A_So_MI_Active	E4_AI_D

Processes:

This function performs CMI encoding of the 139 264 kbit/s signal.

CMI encoder: The function shall perform CMI encoding of the data as specified in ETS 300 166 [4].

The function shall not add any jitter.

NOTE: Jitter at the NNI is the combination of the jitter generated and transferred via the client layers.

Activation: The function shall access the access point when it is activated (MI_Active is true). Otherwise, it shall not access the access point.

Defects: None.

Consequent Actions: None.

Defect Correlations: None.

Performance Monitoring: None.

10.3.4 E4 to P4e Adaptation Sink E4/P4e_A_Sk

Symbol:

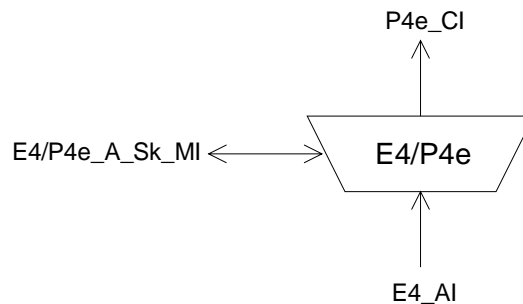

Figure 45: E4/P4e_A_Sk symbol

Interfaces:

Table 30: E4/P4e_Sk input and output signals

Input(s)	Output(s)
E4_AI_D	P4e_CI_D P4e_CI_CK P4e_CI_FS
E4_AI_TSF	P4e_CI_SSF
E4/P4e_A_Sk_MI_AIS_Reported	E4/P4e_A_Sk_MI_cLOF
E4/P4e_A_Sk_MI_Active	E4/P4e_A_Sk_MI_cAIS

Processes:

The function regenerates the received signal, recovers bit timing (CK) and Frame Start reference (FS) from the received signal, and decodes the incoming electrical 139 264 kbit/s E4 signal.

Regeneration: The function shall operate without any errors when any combination of the following signal conditions exist at the input:

- an input electrical amplitude level with any value in the range specified by ETS 300 166 [4];
- jitter modulation applied to the input signal with any value defined in ITU-T Recommendation G.823 [15];
- the input signal bit rate has any value in the range 139 264 kbit/s \pm 15 ppm.

NOTE: The frequency and jitter / wander tolerance might be further constrained by the requirements of the client layers.

CMI decoding: The function shall perform the CMI decoding process specified by ETS 300 166 [4].

Frame alignment: The function shall perform the frame alignment of the 139 264 kbit/s signal to recover the frame start signal FS. Loss of frame alignment shall be assumed to have taken place when four consecutive frame alignment signals have been incorrectly received in their predicted positions.

When frame alignment is assumed to be lost, the frame alignment device shall decide that such alignment has effectively been recovered when it detects the presence of three consecutive frame alignment signals.

The frame alignment device having detected the appearance of a single correct frame alignment signal, shall begin a new search for the frame alignment signal when it detects the absence of the frame alignment signal in one of the two following frames.

Activation: The function shall perform the operation specified above when it is activated (MI_Active is true). Otherwise, it shall transmit the all-ONES signal at its output (CI_D) and not report its status via the management point.

Defects:

The function shall detect a loss of frame defect (dLOF) when four consecutive frame alignment signals have been incorrectly received in their predicted positions. When frame alignment is lost, the dLOF defect shall be cleared when three consecutive frame alignment signals are detected.

The function shall detect an AIS defect (dAIS) according the specification in subclause 8.2.1.7 of EN 300 417-1-1 [8], with $X = 5$, $Y = 2\,928$, $Z = 6$.

Consequent Actions:

aAIS ← dAIS or dLOF or AI_TSF.

aSSF ← dAIS or dLOF or AI_TSF.

On declaration of aAIS the function shall output an all-ONEs (AIS) signal - complying to the frequency limits for this interface - within 250 μ s; on clearing of aAIS the function shall output normal data within 250 μ s.

Defect Correlations:

cAIS ← dAIS and (not AI_TSF) and AIS_Reported.

cLOF ← dLOF and (not dAIS) and (not AI_TSF).

Performance Monitoring: None.

10.3.5 E4 to P4s Adaptation Source E4/P4s_A_So

Symbol:

Figure 46: E4/P4s_A_So symbol

Interfaces:

Table 31: E4/P4s_So input and output signals

Input(s)	Output(s)
P4s_CI_D P4s_CI_CK E4/P4s_A_So_MI_Active	E4_AI_D

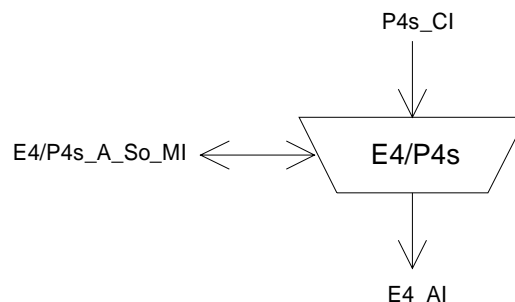
Processes:

This function provides CMI encoding of the 139 264 kbit/s P4s signal.

CMI encoder: The function shall perform CMI encoding of the data as specified in ETS 300 166 [4].

The function shall not add any jitter.

NOTE: Jitter at the NNI is the combination of the jitter generated and transferred via the client layers.

Activation: The function shall access the access point when it is activated (MI_Active is true). Otherwise, it shall not access the access point.

Defects:	None.
Consequent Actions:	None.
Defect Correlations:	None.
Performance Monitoring:	None.

10.3.6 E4 to P4s Adaptation Sink E4/P4s_A_Sk

Symbol:

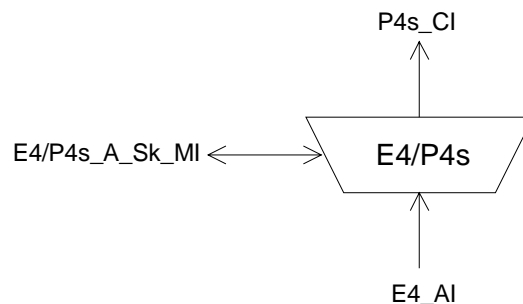

Figure 47: E4/P4s_A_Sk symbol

Interfaces:

Table 32: E4/P4s_Sk input and output signals

Input(s)	Output(s)
E4_AI_D	P4s_CI_D
	P4s_CI_CK
	P4s_CI_FS
E4_AI_TSF	P4s_CI_SSF
E4/P4s_A_Sk_MI_AIS_Reported	E4/P4s_A_Sk_MI_cLOF
E4/P4s_A_Sk_MI_Active	E4/P4s_A_Sk_MI_cAIS

Processes:

The function regenerates the received signal, recovers bit timing (CK), decodes the incoming electrical 139 264 kbit/s E4 signal, and recovers Frame Start reference (FS).

Regeneration: The function shall operate without any errors when any combination of the following signal conditions exist at the input:

- an input electrical amplitude level with any value in the range specified by ETS 300 166 [4];
- jitter modulation applied to the input signal with any value defined in ITU-T Recommendation G.823 [15];
- the input signal bit rate has any value in the range 139 264 kbit/s \pm 15 ppm.

NOTE 1: The frequency and jitter / wander tolerance might be further constrained by the requirements of the client layers.

CMI decoding: The function shall perform the CMI decoding process specified by ETS 300 166 [4].

Frame alignment: The function shall perform the frame alignment of the 139 264 kbit/s signal to recover the frame start signal FS. The frame alignment shall be found by searching for the A1, A2 bytes contained in the 140 Mbit/s signal. The frame signal shall be continuously checked with the presumed frame start position for the alignment.

Frame alignment is deemed to have been lost (entering Out Of Frame (OOF) state) when either:

- four consecutive FAS are detected in error (i.e. ≥ 1 error in each FAS);
- 986 or more frames with one or more BIP8 violations are detected in a block of 1 000 frames.

Frame alignment is deemed to have been recovered (entering In Frame (IF) state) when three consecutive non-error FAS are found.

In the IF state even bit parity (BIP-8) is computed for each bit n of every byte of the preceding frame and compared with bit n of the EM byte recovered from the current frame. A difference between the computed BIP-8 and the EM value is taken as evidence of one or more errors in the previous frame.

NOTE 2: This process is identical with the BIP-8 violation process of the P4s_TT_Sk function. The process may be used in common for both functions.

Should a research for frame alignment be initiated either due to:

- a fortuitous FAS position being found once and not being found a second time in its expected position;
- exceeding the threshold which indicates false alignment;

then the new search for frame alignment should start 1 bit displaced forward from the position of the last indication of frame alignment.

NOTE 3: The above is required in order to avoid repeated alignment on to a simulation of the framing location.

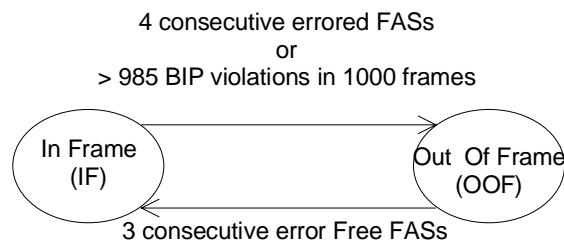

Figure 48: Frame alignment state diagram

Activation: The function shall perform the operation specified above when it is activated (MI_Active is true). Otherwise, it shall transmit the all-ONES signal at its output (CI_D) and not report its status via the management point.

Defects:

If the frame alignment is deemed to be lost (OOF state), a 140 Mbit/s Loss Of Frame defect (dLOF) shall be detected. The dLOF defect shall be cleared when the frame alignment is deemed to have been recovered (IF state).

The dAIS defect shall be detected specified by EN 300 417-1-1 [8], subclause 8.2.1.7 for 140 Mbit/s, with $X = 7$, $Y = 17\,408$, $Z = 8$.

Consequent Actions:

aAIS ← dAIS or dLOF or AI_TSF.

aSSF ← dAIS or dLOF or AI_TSF.

On declaration of aAIS the function shall output an all-ONES (AIS) signal - complying to the frequency limits for this interface - within 250 μ s; on clearing of aAIS the function shall output normal data within 250 μ s.

Defect Correlations:

cAIS ← dAIS and (not AI_TSF) and AIS_Reported.

cLOF ← dLOF and (not dAIS) and (not AI_TSF).

Performance Monitoring:

None.

11 E31 Section Layer Functions

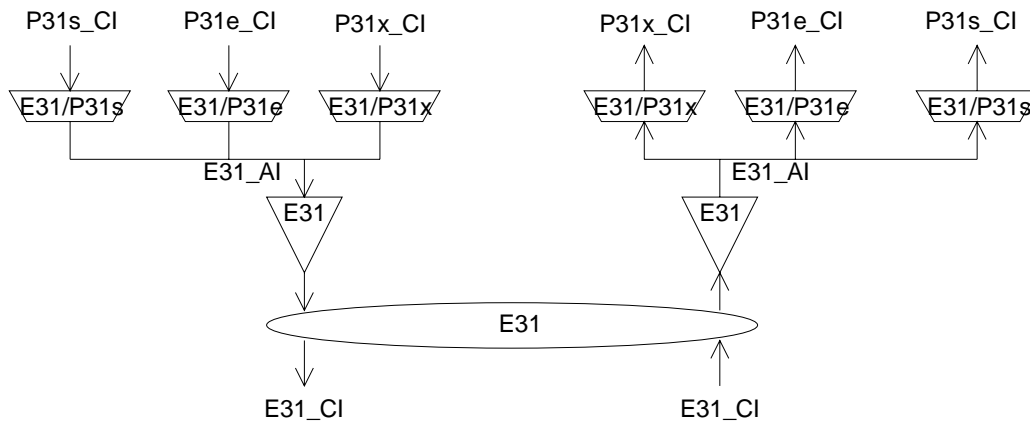

Figure 49: E31 Section atomic functions

E31 layer CP

The Characteristic Information E31_CI of the intra-station electrical layer CP is a digital, electrical signal of defined amplitude, bit rate and pulse shape specified by ETS 300 166 [4].

E31 layer AP

The information passing across the E31/P31x AP is a 34 368 kbit/s signal of non-specified content with co-directional bit timing.

The information passing across the E31/P31e AP is a 34 368 kbit/s signal with co-directional bit timing specified by CCITT Recommendation G.751 [13]. It contains four 8 448 kbit/s tributary signals (see figure 50).

Figure 49 shows that more than one adaptation function exists in this E31 layer that can be connected to one E31 access point. For the case of the adaptation source functions, only one of these adaptation source functions is allowed to be activated. For this activated source, access to the access point by other adaptation source functions shall be denied. In contradiction with the source direction, adaptation sink functions may be activated all together. This may cause faults (e.g. cLOF) to be detected and reported. To prevent this an adaptation sink function can be deactivated.

NOTE: If one adaptation function only is connected to the AP, it will be activated. If one or more other functions are connected to the same AP, one out of the set of functions will be active.

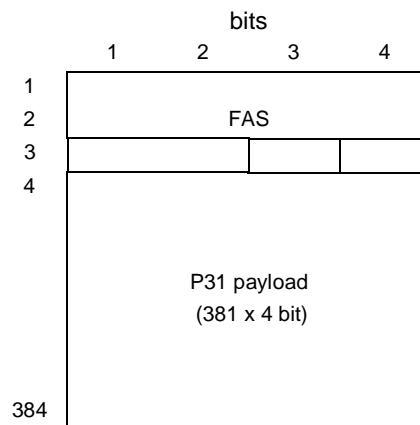

Figure 50: Decoded E31/P31e_AI_D signal

The information passing across the E31/P31s AP is a 34 368 kbit/s signal with co-directional bit timing specified by ETS 300 337 [7] (see figure 51).

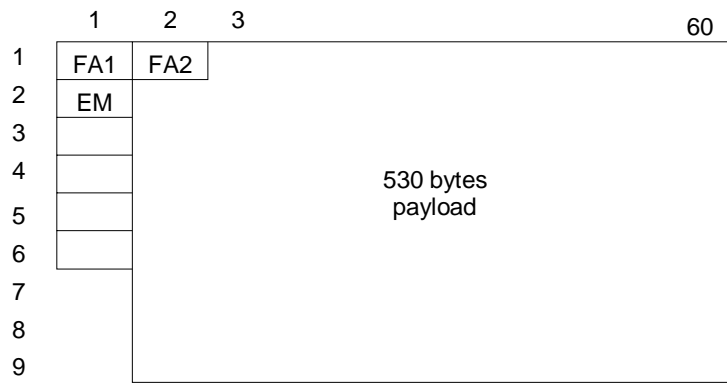

Figure 51: Decoded E31/P31s_AI_D signal

11.1 E31 Connection function E31_C

For further study.

11.2 E31 Trail Termination functions

11.2.1 E31 Trail Termination Source E31_TT_So

Symbol:

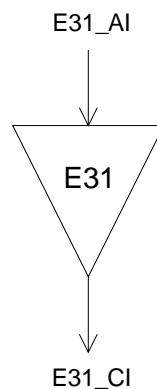

Figure 52: E31_TT_So symbol

Interfaces:

Table 33: E31_TT_So input and output signals

Input(s)	Output(s)
E31_AI_D	E31_CI_D

Processes:

This function generates the electrical Intra-station Section Layer signal E31 specified by ETS 300 166 [4].

Pulse shape: The function shall meet the requirement specified by ETS 300 166 [4].

Nominal Peak to Peak Voltage of a mark (pulse): The function shall meet the requirement specified by ETS 300 166 [4].

Peak voltage of a space (no pulse): The function shall meet the requirement specified by ETS 300 166 [4].

Nominal pulse width: The function shall meet the requirement specified by ETS 300 166 [4].

Ratio of the amplitudes of positive and negative pulses at the centre of the pulse interval: The function shall meet the requirement specified by ETS 300 166 [4].

Ratio of widths of positive and negative pulses at the nominal half amplitude: The function shall meet the requirement specified by ETS 300 166 [4].

Pair(s) in each direction: The function shall meet the requirement specified by ETS 300 166 [4].

Output return loss: The function shall meet the requirement specified by ETS 300 166 [4].

Defects: None.

Consequent Actions: None.

Defect Correlations: None.

Performance Monitoring: None.

11.2.2 E31 Trail Termination Sink E31_TT_Sk

Symbol:

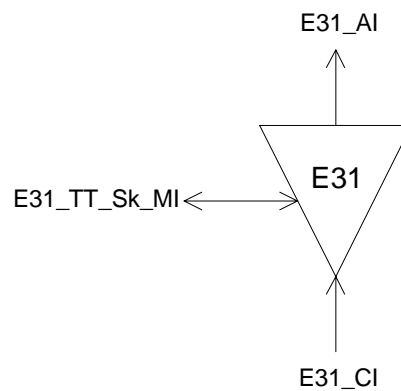

Figure 53: E31_TT_Sk symbol

Interfaces:

Table 34: E31_TT_Sk input and output signals

Input(s)	Output(s)
E31_CI_D	E31_AI_D E31_AI_TSF
E31_TT_Sk_MI_PortMode	E31_TT_Sk_MI_cLOS

Processes:

This function recovers the electrical Intra-station Section Layer signal E31 specified by ETS 300 166 [4].

Input return loss: The function shall meet the requirement specified by ETS 300 166 [4].

Port Mode: The function shall have a port mode as specified by subclause 8.5 of EN 300 417-1-1 [8].

NOTE: The AUTO state of the port mode process is optional.

Defects:

The function shall detect Loss Of Signal defect (dLOS) according the 34 368 kbit/s dLOS specification in subclause 8.2.1.6 of EN 300 417-1-1 [8].

Consequent Actions:

aTSF ← dLOS.

Defect Correlations:

cLOS ← MON and dLOS.

Performance Monitoring: None.

11.3 E31 Adaptation functions

11.3.1 E31 to P31x Adaptation Source E31/P31x_A_So

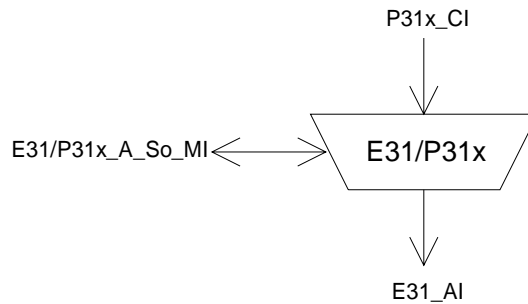
Symbol:**Figure 54: E31/P31x_A_So symbol****Interfaces:****Table 35: E31/P31x_A_So input and output signals**

Input(s)	Output(s)
P31x_CI_D P31x_CI_CK E31/P31x_A_So_MI_Active	E31_AI_D

Processes:

This function provides the HDB3 encoding of the 34 368 kbit/s information stream specified by ETS 300 166 [4].

HDB3 encoder: The function shall perform HDB3 encoding of the data as specified in ETS 300 166 [4].

The function shall not add any jitter.

NOTE: Jitter at the NNI is the combination of the jitter generated and transferred via the client layers.

Activation: The function shall access the access point when it is activated (MI_Active is true). Otherwise, it shall not access the access point.

Defects: None.**Consequent Actions:** None.**Defect Correlations:** None.**Performance Monitoring:** None.

11.3.2 E31 to P31x Adaptation Sink E31/P31x_A_Sk

Symbol:

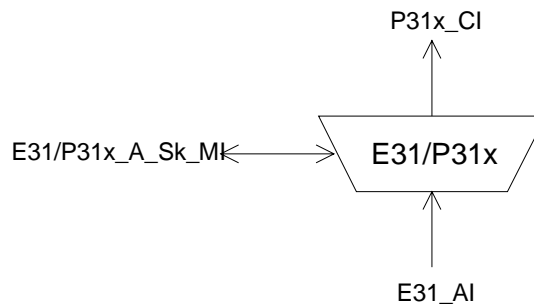

Figure 55: E31/P31x_A_Sk symbol

Interfaces:

Table 36: E31/P31x_A_Sk input and output signals

Input(s)	Output(s)
E31_AI_D	P31x_CI_D
E31_AI_TSF	P31x_CI_CK
E31/P31x_A_Sk_MI_Active	P31x_CI_SSF

Processes:

This function regenerates the received signal, recovers bit timing (CK) from the received signal, and decodes the incoming electrical 34 368 kbit/s E31 signal.

Regeneration: The function shall operate without any errors when any combination of the following signal conditions exist at the input:

- an input electrical amplitude level with any value in the range specified by ETS 300 166 [4];
- jitter modulation applied to the input signal with any value defined in ITU-T Recommendation G.823 [15];
- the input signal bit rate has any value in the range 34 368 kbit/s \pm 20 ppm;
- the input signal has an interfering signal specified by ETS 300 166 [4].

NOTE: The frequency and jitter / wander tolerance might be further constrained by the requirements of the client layers.

HDB3 decoding: The function shall perform the HDB3 decoding process specified by ETS 300 166 [4].

Activation: The function shall perform the operation specified above when it is activated (MI_Active is true). Otherwise, it shall transmit the all-ONES signal at its output (CI_D) and not report its status via the management point.

Defects: None.

Consequent Actions:

aSSF ← AI_TSF.

aAIS ← AI_TSF.

On declaration of aAIS the function shall output an all-ONES (AIS) signal - complying to the frequency limits for this interface - within 250 μ s; on clearing of aAIS the function shall output normal data within 250 μ s.

Defect Correlations: None.

Performance Monitoring: None.

11.3.3 E31 to P31e Adaptation Source E31/P31e_A_So

Symbol:

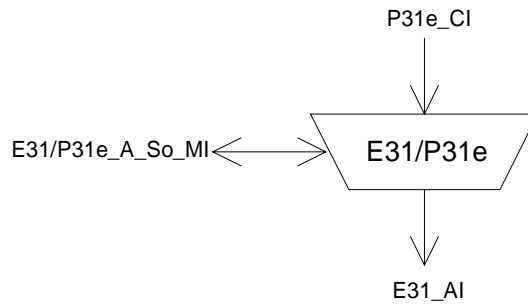

Figure 56: E31/P31e_A_So symbol

Interfaces:

Table 37: E31/P31e_A_So input and output signals

Input(s)	Output(s)
P31e_CI_D P31e_CI_CK E31/P31e_A_So_MI_Active	E31_AI_D

Processes:

This function performs HDB3 encoding of the 34 368 kbit/s signal.

HDB3 encoder: The function shall perform HDB3 encoding of the data as specified in ETS 300 166 [4].

The function shall not add any jitter.

NOTE: Jitter at the NNI is the combination of the jitter generated and transferred via the client layers.

Activation: The function shall access the access point when it is activated (MI_Active is true). Otherwise, it shall not access the access point.

Defects: None.

Consequent Actions: None.

Defect Correlations: None.

Performance Monitoring: None.

11.3.4 E31 to P31e Adaptation Sink E31/P31e_A_Sk

Symbol:

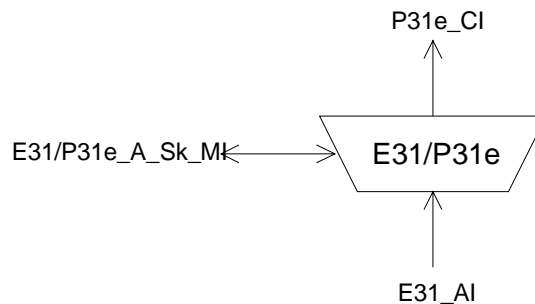

Figure 57: E31/P31e_A_Sk symbol

Interfaces:

Table 38: E31/P31e_A_Sk input and output signals

Input(s)	Output(s)
E31_AI_D	P31e_CI_D
	P31e_CI_CK
	P31e_CI_FS
E31_AI_TSF	P31e_CI_SSF
E31/P31e_A_Sk_MI_AIS_Reported	E31/P31e_A_Sk_MI_cLOF
E31/P31e_A_Sk_MI_Active	E31/P31e_A_Sk_MI_cAIS

Processes:

The function regenerates the received signal, recovers bit timing (CK) and Frame Start reference (FS) from the received signal, and decodes the incoming electrical 34 368 kbit/s E31 signal.

Regeneration: The function shall operate without any errors when any combination of the following signal conditions exist at the input:

- an input electrical amplitude level with any value in the range specified by ETS 300 166 [4];
- jitter modulation applied to the input signal with any value defined in ITU-T Recommendation G.823 [15];
- the input signal bit rate has any value in the range 34 368 kbit/s \pm 20 ppm;
- the input signal has an interfering signal specified by ETS 300 166 [4].

NOTE: The frequency and jitter / wander tolerance might be further constrained by the requirements of the client layers.

HDB3 decoding: The function shall perform the HDB3 decoding process specified by ETS 300 166 [4].

Frame alignment: The function shall perform the frame alignment of the 34 368 kbit/s signal to recover the frame start signal FS. Loss of frame alignment shall be assumed to have taken place when four consecutive frame alignment signals have been incorrectly received in their predicted positions.

When frame alignment is assumed to be lost, the frame alignment device shall decide that such alignment has effectively been recovered when it detects the presence of three consecutive frame alignment signals.

The frame alignment device having detected the appearance of a single correct frame alignment signal, shall begin a new search for the frame alignment signal when it detects the absence of the frame alignment signal in one of the two following frames.

Activation: The function shall perform the operation specified above when it is activated (MI_Active is true). Otherwise, it shall transmit the all-ONES signal at its output (CI_D) and not report its status via the management point.

Defects:

The function shall detect a loss of frame defect (dLOF) when four consecutive frame alignment signals have been incorrectly received in their predicted positions. When frame alignment is lost, the dLOF defect shall be cleared when three consecutive frame alignment signals are detected.

The function shall detect an AIS defect (dAIS) according the specification in subclause 8.2.1.7 of EN 300 417-1-1 [8], with X = 4, Y = 1 536, Z = 5.

Consequent Actions:

aAIS ← dAIS or dLOF or AI_TSF.

aSSF ← dAIS or dLOF or AI_TSF.

On declaration of aAIS the function shall output an all-ONEs (AIS) signal - complying to the frequency limits for this interface - within 250 µs; on clearing of aAIS the function shall output normal data within 250 µs.

Defect Correlations:

cAIS ← dAIS and (not AI_TSF) and AIS_Reported.

cLOF ← dLOF and (not dAIS) and (not AI_TSF).

Performance Monitoring: None.

11.3.5 E31 to P31s Adaptation Source E31/P31s_A_So

Symbol:

Figure 58: E31/P31s_A_So symbol

Interfaces:

Table 39: E31/P31s_A_So input and output signals

Input(s)	Output(s)
P31s_CI_D P31s_CI_CK E31/P31s_A_So_MI_Active	E31_AI_D

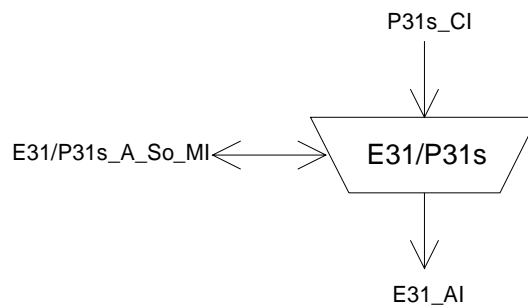
Processes:

This function provides HDB3 encoding of the 34 368 kbit/s P31s signal.

HDB3 encoder: The function shall perform HDB3 encoding of the data as specified in ETS 300 166 [4].

The function shall not add any jitter.

NOTE: Jitter at the NNI is the combination of the jitter generated and transferred via the client layers.

Activation: The function shall access the access point when it is activated (MI_Active is true). Otherwise, it shall not access the access point.

Defects:	None.
Consequent Actions:	None.
Defect Correlations:	None.
Performance Monitoring:	None.

11.3.6 E31 to P31s Adaptation Sink E31/P31s_A_Sk

Symbol:

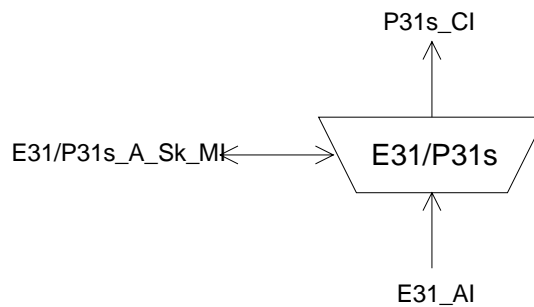

Figure 59: E31/P31s_A_Sk symbol

Interfaces:

Table 40: E31/P31s_A_Sk input and output signals

Input(s)	Output(s)
E31_AI_D	P31s_CI_D P31s_CI_CK P31s_CI_FS
E31_AI_TSF	P31s_CI_SSF
E31/P31s_A_Sk_MI_AIS_Reported	E31/P31s_A_Sk_MI_cLOF
E31/P31s_A_Sk_MI_Active	E31/P31s_A_Sk_MI_cAIS

Processes:

The function regenerates the received signal, recovers bit timing (CK), decodes the incoming electrical 34 368 kbit/s E31 signal, and recovers Frame Start reference (FS). It supplies the recovered timing signal to the synchronization distribution layer. It can be activated / deactivated when multiple adaptation function types are connected to the access point.

Regeneration: The function shall operate without any errors when any combination of the following signal conditions exist at the input:

- an input electrical amplitude level with any value in the range specified by ETS 300 166 [4];
- jitter modulation applied to the input signal with any value defined in ITU-T Recommendation G.823 [15];
- the input signal bit rate has any value in the range 34 368 kbit/s \pm 20 ppm;
- the input signal has an interfering signal specified by ETS 300 166 [4].

NOTE 1: The frequency and jitter / wander tolerance might be further constrained by the requirements of the client layers.

HDB3 decoding: The function shall perform the HDB3 decoding process specified by ETS 300 166 [4].

Frame alignment: The function shall perform the frame alignment of the 34 368 kbit/s signal to recover the frame start signal FS. The frame alignment shall be found by searching for the A1, A2 bytes contained in the 34 Mbit/s signal. The frame signal shall be continuously checked with the presumed frame start position for the alignment.

Frame alignment is deemed to have been lost (entering Out Of Frame (OOF) state) when either:

- four consecutive FAS are detected in error (i.e. ≥ 1 error in each FAS);
- 986 or more frames with one or more BIP8 violations are detected in a block of 1 000 frames.

Frame alignment is deemed to have been recovered (entering In Frame (IF) state) when three consecutive non-error FAS are found.

In the IF state even bit parity (BIP-8) is computed for each bit n of every byte of the preceding frame and compared with bit n of the EM byte recovered from the current frame. A difference between the computed BIP-8 and the EM value is taken as evidence of one or more errors in the previous frame.

NOTE 2: This process is identical with the BIP-8 violation process of the P31s_TT_Sk function. The process may be used in common for both functions.

Should a research for frame alignment be initiated either due to:

- a fortuitous FAS position being found once and not being found a second time in its expected position;
- exceeding the threshold which indicates false alignment;

then the new search for frame alignment should start 1 bit displaced forward from the position of the last indication of frame alignment.

NOTE 3: The above is required in order to avoid repeated alignment on to a simulation of the framing location.

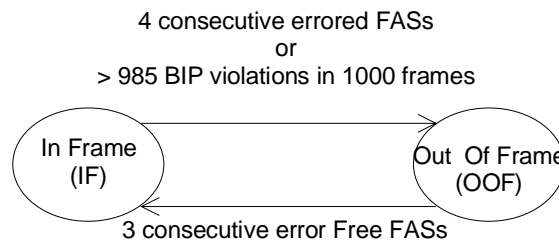

Figure 60: Frame alignment state diagram

Activation: The function shall perform the operation specified above when it is activated (MI_Active is true).

Otherwise, it shall transmit the all-ONES signal at its output (CI_D) and not report its status via the management point.

Defects:

If the frame alignment is deemed to be lost (OOF state), a 34 Mbit/s Loss Of Frame defect (dLOF) shall be detected. The dLOF defect shall be cleared when the frame alignment is deemed to have been recovered (IF state).

The dAIS defect shall be detected specified by EN 300 417-1-1 [8], subclause 8.2.1.7 for 34 Mbit/s, with X = 7, Y = 4 296, Z = 8.

Consequent Actions:

aAIS ← dAIS or dLOF or AI_TSF.

aSSF ← dAIS or dLOF or AI_TSF.

On declaration of aAIS the function shall output an all-ONES (AIS) signal - complying to the frequency limits for this interface - within 250 μ s; on clearing of aAIS the function shall output normal data within 250 μ s.

Defect Correlations:

cAIS ← dAIS and (not AI_TSF) and AIS_Reported.

cLOF ← dLOF and (not dAIS) and (not AI_TSF).

Performance Monitoring: None.

12 E22 Section Layer Functions

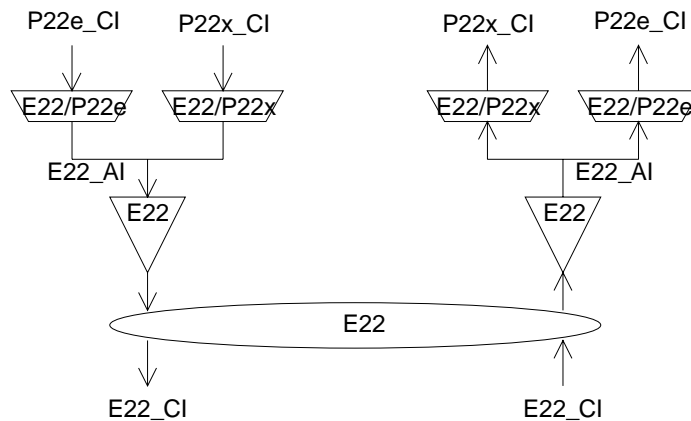

Figure 61: E22 Section atomic functions

E22 layer CP

The Characteristic Information E22_CI of the intra-station electrical CP is a digital, electrical signal of defined amplitude, bit rate and pulse shape specified by ETS 300 166 [4].

E22 layer AP

The information passing across the E22/P22x AP is a 8 448 kbit/s signal with co-directional bit timing.

The information passing across the E22/P22e AP is a 8 448 kbit/s signal with co-directional bit timing. It contains four 2 048 kbit/s tributary signals (see figure 62).

Figure 61 shows that more than one adaptation function exists in this E22 layer that can be connected to one E22 access point. For the case of the adaptation source functions, only one of these adaptation source functions is allowed to be activated. For this activated source, access to the access point by other adaptation source functions shall be denied. In contradiction with the source direction, adaptation sink functions may be activated all together. This may cause faults (e.g. cLOF) to be detected and reported. To prevent this an adaptation sink function can be deactivated.

NOTE: If one adaptation function only is connected to the AP, it will be activated. If one or more other functions are connected to the same AP, one out of the set of functions will be active.

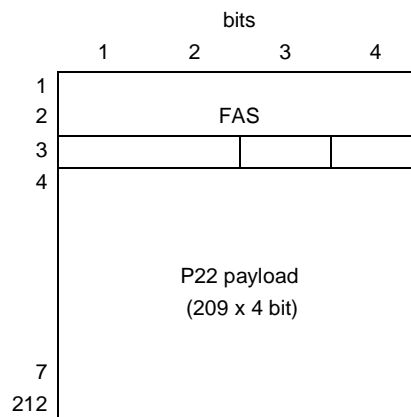

Figure 62: Decoded E22/P22e_AI_D signal

12.1 E22 Connection function E22_C

For further study.

12.2 E22 Trail Termination functions

12.2.1 E22 Trail Termination Source E22_TT_So

Symbol:

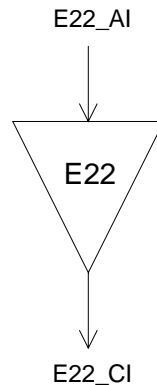

Figure 63: E22_TT_So symbol

Interfaces:

Table 41: E22_TT_So input and output signals

Input(s)	Output(s)
E22_AI_D	E22_CI_D

Processes:

This function generates the electrical Intra-station Section Layer signal E22 specified by ETS 300 166 [4].

Pulse shape: The function shall meet the requirement specified by ETS 300 166 [4].

Nominal Peak Voltage of a mark (pulse): The function shall meet the requirement specified by ETS 300 166 [4].

Peak voltage of a space (no pulse): The function shall meet the requirement specified by ETS 300 166 [4].

Nominal pulse width: The function shall meet the requirement specified by ETS 300 166 [4].

Ratio of the amplitudes of positive and negative pulses at the centre of the pulse interval: The function shall meet the requirement specified by ETS 300 166 [4].

Ratio of widths of positive and negative pulses at the nominal half amplitude: The function shall meet the requirement specified by ETS 300 166 [4].

Pair(s) in each direction: The function shall meet the requirement specified by ETS 300 166 [4].

Output return loss: The function shall meet the requirement specified by ETS 300 166 [4].

Defects: None.

Consequent Actions: None.

Defect Correlations: None.

Performance Monitoring: None.

12.2.2 E22 Trail Termination Sink E22_TT_Sk

Symbol:

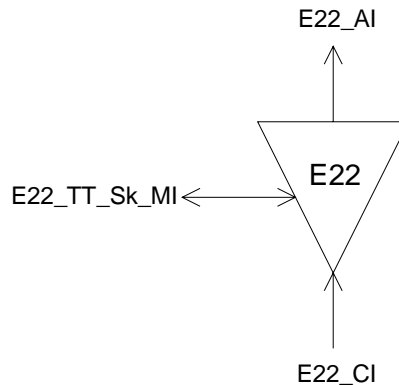

Figure 64: E22_TT_Sk symbol

Interfaces:

Table 42: E22_TT_Sk input and output signals

Input(s)	Output(s)
E22_CI_D	E22_AI_D E22_AI_TSF
E22_TT_Sk_MI_PortMode	E22_TT_Sk_MI_cLOS

Processes:

This function recovers the electrical Intra-station Section Layer signal E22 specified by ETS 300 166 [4].

Input return loss: The function shall meet the requirement specified by ETS 300 166 [4].

Port Mode: The function shall have a port mode as specified by subclause 8.5 of EN 300 417-1-1 [8].

NOTE: The AUTO state of the port mode process is optional.

Defects:

The function shall detect Loss Of Signal defect (dLOS) according the 8 448 kbit/s dLOS specification in subclause 8.2.1.6 of EN 300 417-1-1 [8].

Consequent Actions:

aTSF ← dLOS.

Defect Correlations:

cLOS ← MON and dLOS.

Performance Monitoring: None.

12.3 E22 Adaptation functions

12.3.1 E22 to P22x Adaptation Source E22/P22x_A_So

Symbol:

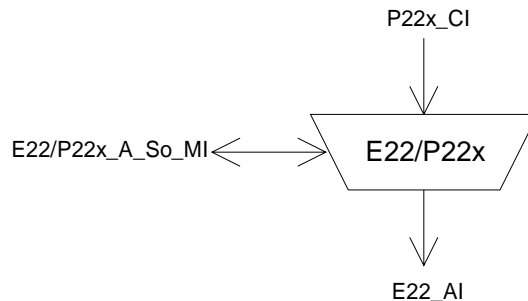

Figure 65: E22/P22x_A_So symbol

Interfaces:

Table 43: E22/P22x_A_So input and output signals

Input(s)	Output(s)
P22x_CI_D P22x_CI_CK E22/P22x_A_So_MI_Active	E22_AI_D

Processes:

This function provides the HDB3 encoding of the 8 448 kbit/s information stream specified by ETS 300 166 [4].

HDB3 encoder: The function shall perform HDB3 encoding of the data as specified in ETS 300 166 [4].

The function shall not add any jitter.

NOTE: Jitter at the NNI is the combination of the jitter generated and transferred via the client layers.

Activation: The function shall access the access point when it is activated (MI_Active is true). Otherwise, it shall not access the access point.

Defects: None.

Consequent Actions: None.

Defect Correlations: None.

Performance Monitoring: None.

12.3.2 E22 to P22x Adaptation Sink E22/P22x_A_Sk

Symbol:

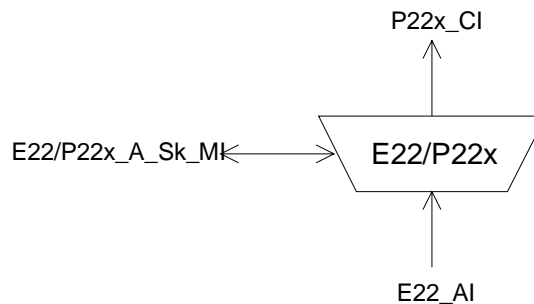

Figure 66: E22/P22x_A_Sk symbol

Interfaces:

Table 44: E22/P22x_A_Sk input and output signals

Input(s)	Output(s)
E22_AI_D	P22x_CI_D
E22_AI_TSF	P22x_CI_CK
E22/P22x_A_Sk_MI_Active	P22x_CI_SSF

Processes:

This function regenerates the received signal, recovers bit timing (CK) from the received signal, and decodes the incoming electrical 8 448 kbit/s E22 signal.

Regeneration: The function shall operate without any errors when any combination of the following signal conditions exist at the input:

- an input electrical amplitude level with any value in the range specified by ETS 300 166 [4];
- jitter modulation applied to the input signal with any value defined in ITU-T Recommendation G.823 [15];
- the input signal bit rate has any value in the range $8\,448\text{ kbit/s} \pm 30\text{ ppm}$;
- the input signal has an interfering signal specified by ETS 300 166 [4].

NOTE: The frequency and jitter / wander tolerance might be further constrained by the requirements of the client layers.

HDB3 decoding: The function shall perform the HDB3 decoding process specified by ETS 300 166 [4].

Activation: The function shall perform the operation specified above when it is activated (MI_Active is true). Otherwise, it shall transmit the all-ONES signal at its output (CI_D) and not report its status via the management point.

Defects: None.

Consequent Actions:

aSSF ← AI_TSF.

aAIS ← AI_TSF.

On declaration of aAIS the function shall output an all-ONES (AIS) signal - complying to the frequency limits for this interface - within 250 μ s; on clearing of aAIS the function shall output normal data within 250 μ s.

Defect Correlations: None.

Performance Monitoring: None.

12.3.3 E22 to P22e Adaptation Source E22/P22e_A_So

Symbol:

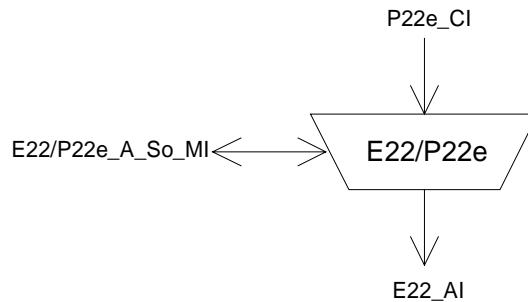

Figure 67: E22/P22e_A_So symbol

Interfaces:

Table 45: E22/P22e_A_So input and output signals

Input(s)	Output(s)
P22e_CI_D P22e_CI_CK E22/P22e_A_So_MI_Active	E22_AI_D

Processes:

This function performs HDB3 encoding of the 8 448 kbit/s signal.

HDB3 encoder: The function shall perform HDB3 encoding of the data as specified in ETS 300 166 [4].

The function shall not add any jitter.

NOTE: Jitter at the NNI is the combination of the jitter generated and transferred via the client layers.

Activation: The function shall access the access point when it is activated (MI_Active is true). Otherwise, it shall not access the access point.

Defects: None.

Consequent Actions: None.

Defect Correlations: None.

Performance Monitoring: None.

12.3.4 E22 to P22e Adaptation Sink E22/P22e_A_Sk

Symbol:

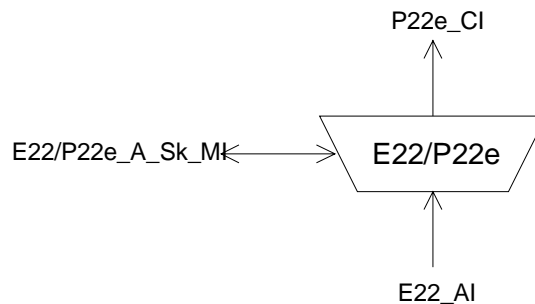

Figure 68: E22/P22e_A_Sk symbol

Interfaces:

Table 46: E22/P22e_A_Sk input and output signals

Input(s)	Output(s)
E22_AI_D	P22e_CI_D
	P22e_CI_CK
	P22e_CI_FS
E22_AI_TSF	P22e_CI_SSF
E22/P22e_A_Sk_MI_AIS_Reported	E22/P22e_A_Sk_MI_cLOF
E22/P22e_A_Sk_MI_Active	E22/P22e_A_Sk_MI_cAIS

Processes:

The function regenerates the received signal, recovers bit timing (CK) and Frame Start reference (FS) from the received signal, and decodes the incoming electrical 8 448 kbit/s E22 signal. It can be activated / deactivated when multiple adaptation function types are connected to the access point.

Regeneration: The function shall operate without any errors when any combination of the following signal conditions exist at the input:

- an input electrical amplitude level with any value in the range specified by ETS 300 166 [4];
- jitter modulation applied to the input signal with any value defined in ITU-T Recommendation G.823 [15];
- the input signal bit rate has any value in the range 8 448 kbit/s \pm 30 ppm;
- the input signal has an interfering signal specified by ETS 300 166 [4].

HDB3 decoding: The function shall perform the HDB3 decoding process specified by ETS 300 166 [4].

Frame alignment: The function shall perform the frame alignment of the 8 448 kbit/s signal to recover the frame start signal FS. Loss of frame alignment shall be assumed to have taken place when four consecutive frame alignment signals have been incorrectly received in their predicted positions.

When frame alignment is assumed to be lost, the frame alignment device shall decide that such alignment has effectively been recovered when it detects the presence of three consecutive frame alignment signals.

The frame alignment device having detected the appearance of a single correct frame alignment signal, shall begin a new search for the frame alignment signal when it detects the absence of the frame alignment signal in one of the two following frames.

Activation: The function shall perform the operation specified above when it is activated (MI_Active is true). Otherwise, it shall transmit the all-ONES signal at its output (CI_D) and not report its status via the management point.

Defects:

The function shall detect a loss of frame defect (dLOF) when four consecutive frame alignment signals have been incorrectly received in their predicted positions. When frame alignment is lost, the dLOF defect shall be cleared when three consecutive frame alignment signals are detected.

The function shall detect an AIS defect (dAIS) according the specification in subclause 8.2.1.7 of EN 300 417-1-1 [8], with $X = 4$, $Y = 848$, $Z = 5$.

Consequent Actions:

aAIS ← dAIS or dLOF or AI_TSF;

aSSF ← dAIS or dLOF or AI_TSF.

On declaration of aAIS the function shall output an all-ONEs (AIS) signal - complying to the frequency limits for this interface - within 250 μ s; on clearing of aAIS the function shall output normal data within 250 μ s.

Defect Correlations:

cAIS ← dAIS and (not AI_TSF) and AIS_Reported;

cLOF ← dLOF and (not dAIS) and (not AI_TSF).

Performance Monitoring: None.

13 E12 Section Layer Functions

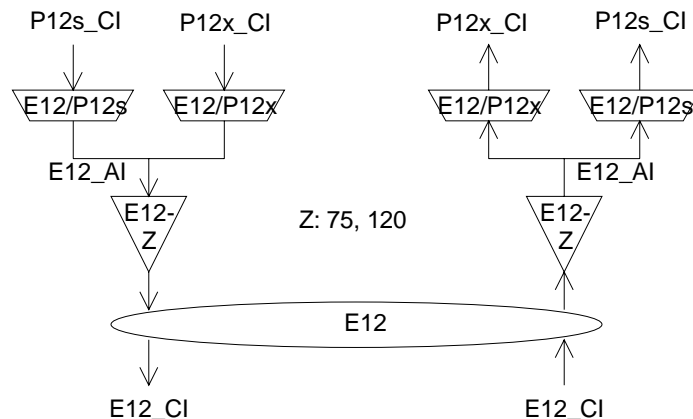

Figure 69: E12 Section atomic functions

E12 layer CP

The Characteristic Information E12_CI of the intra-station electrical CP is a digital, electrical signal of defined amplitude, bit rate, impedance and pulse shape specified by ETS 300 166 [4].

NOTE 1: The specification within the present document is limited to the Network Node Interface (NNI).

E12 layer AP

The information passing across the E12/P12x AP is a 2 048 kbit/s signal with co-directional bit timing.

The information passing across the E12/P12s AP is a 2 048 kbit/s signal with co-directional bit timing with a frame structure specified by ETS 300 167 [5] (see figures 70 and 71).

Figure 69 shows that more than one adaptation function exists in this E12 layer that can be connected to one E12 access point. For the case of the adaptation source functions, only one of these adaptation source functions is allowed to be activated. For this activated source, access to the access point by other adaptation source functions shall be denied. In contradiction with the source direction, adaptation sink functions may be activated all together. This may cause faults (e.g. cLOF) to be detected and reported. To prevent this an adaptation sink function can be deactivated.

NOTE 2: If one adaptation function only is connected to the AP, it will be activated. If one or more other functions are connected to the same AP, one out of the set of functions will be active.

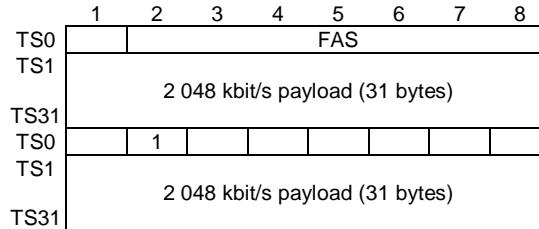

Figure 70: Decoded P12s_CI_D (without CRC-4 multiframe)

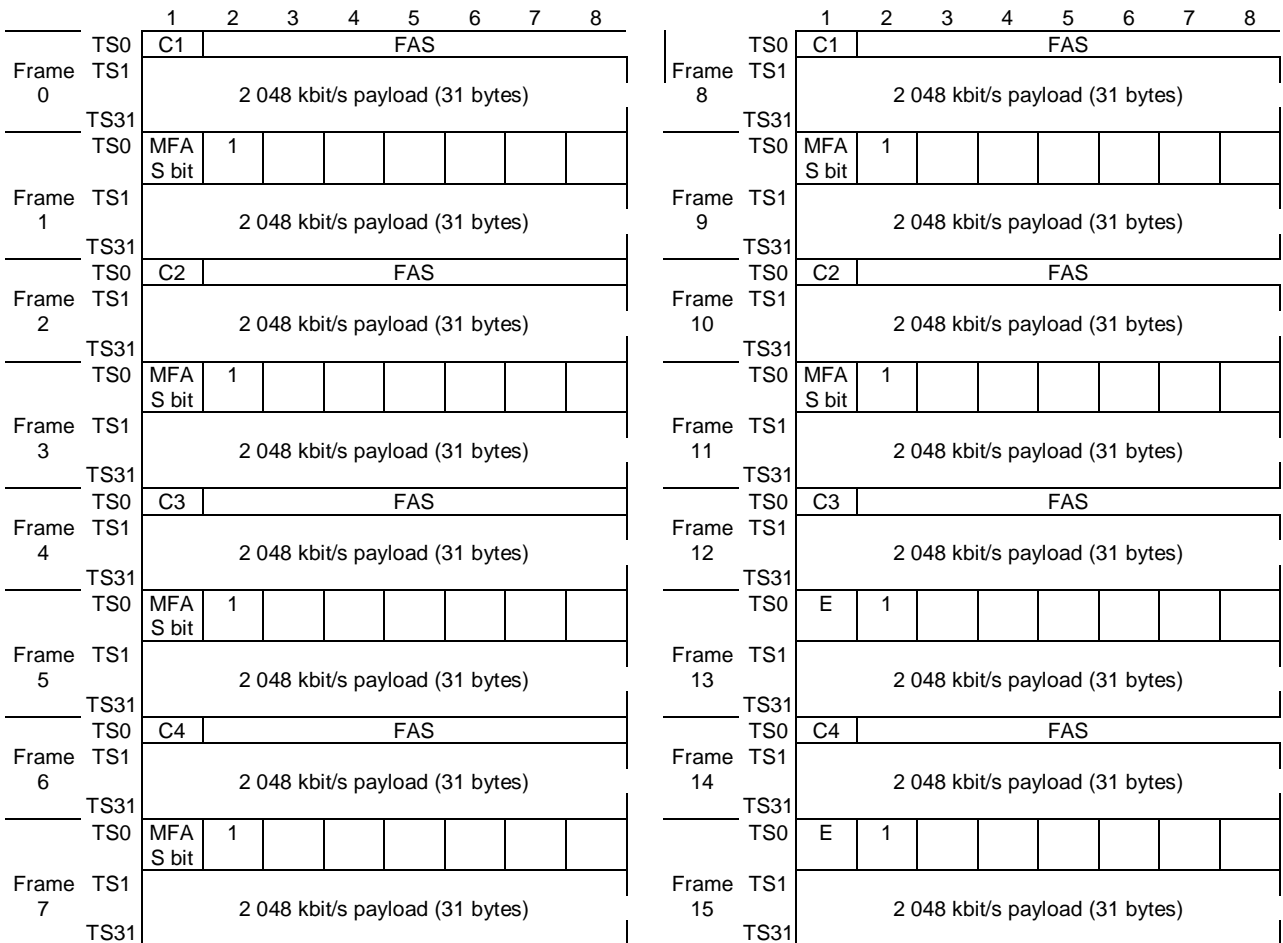

Figure 71: Decoded P12s_CI_D (with CRC-4 multiframe)

13.1 E12 Connection function E12_C

For further study.

13.2 E12 Trail Termination functions

13.2.1 E12 Trail Termination Source E12-Z_TT_So

NOTE: Z (Ω) will be one value out of the set: {75, 120} (Ω).

Symbol:

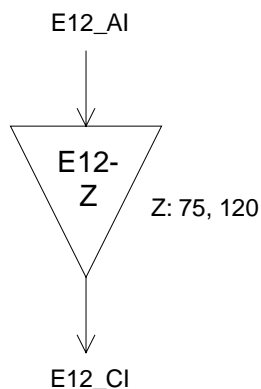

Figure 72: E12-Z_TT_So symbol

Interfaces:

Table 47: E12_TT_So input and output signals

Input(s)	Output(s)
E12_AI_D	E12_CI_D

Processes:

This function generates the electrical Intra-station Section Layer signal E12 specified by ETS 300 166 [4].

Pulse shape: The function shall meet the requirement specified by ETS 300 166 [4].

Nominal Peak Voltage of a mark (pulse): The function shall meet the requirement specified by ETS 300 166 [4].

Peak voltage of a space (no pulse): The function shall meet the requirement specified by ETS 300 166 [4].

Nominal pulse width: The function shall meet the requirement specified by ETS 300 166 [4].

Ratio of the amplitudes of positive and negative pulses at the centre of the pulse interval: The function shall meet the requirement specified by ETS 300 166 [4].

Ratio of widths of positive and negative pulses at the nominal half amplitude: The function shall meet the requirement specified by ETS 300 166 [4].

Pair(s) in each direction: The function shall meet the requirement specified by ETS 300 166 [4].

Output return loss: The function shall meet the requirement specified by ETS 300 166 [4].

Output signal balance: For the case of a 120 Ω interface, the function shall meet the requirement specified by ETS 300 166 [4].

Defects:	None.
Consequent Actions:	None.
Defect Correlations:	None.
Performance Monitoring:	None.

13.2.2 E12 Trail Termination Sink E12-Z_TT_Sk

NOTE: Z (Ω) will be one value out of the set: {75, 120} (Ω).

Symbol:

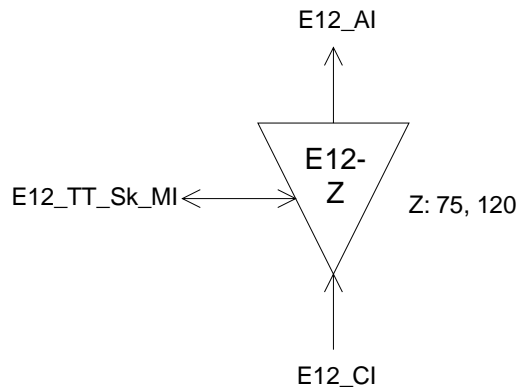

Figure 73: E12-Z_TT_Sk symbol

Interfaces:

Table 48: E12_TT_Sk input and output signals

Input(s)	Output(s)
E12_CI_D	E12_AI_D E12_AI_TSF
E12_TT_Sk_MI_PortMode	E12_TT_Sk_MI_cLOS

Processes:

This function recovers the electrical Intra-station Section Layer signal E12 specified by ETS 300 166 [4].

Input return loss: The function shall meet the requirement specified by ETS 300 166 [4].

Port Mode: The function shall have a port mode as specified by subclause 8.5 of EN 300 417-1-1 [8].

NOTE: The AUTO state of the port mode process is optional.

Defects:

The function shall detect Loss Of Signal defect (dLOS) according the 2 048 kbit/s dLOS specification in subclause 8.2.1.6 of EN 300 417-1-1 [8].

Consequent Actions:

aTSF ← dLOS.

Defect Correlations:

cLOS ← MON and dLOS.

Performance Monitoring: None.

13.3 E12 Adaptation functions

13.3.1 E12 to P12x Adaptation Source E12/P12x_A_So

Symbol:

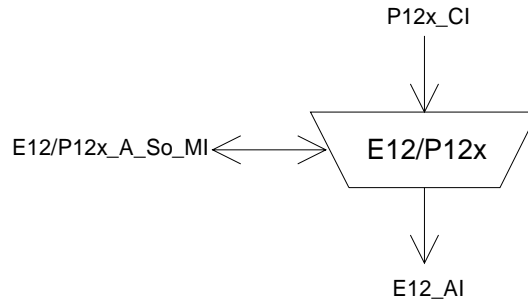

Figure 74: E12/P12x_A_So symbol

Interfaces:

Table 49: E12/P12x_A_So input and output signals

Input(s)	Output(s)
P12x_CI_D P12x_CI_CK E12/P12x_A_So_MI_Active	E12_AI_D

Processes:

This function provides the HDB3 encoding of the 2 048 kbit/s information stream specified by ETS 300 166 [4].

HDB3 encoder: The function shall perform HDB3 encoding of the data as specified in ETS 300 166 [4].

The function shall not add any jitter.

NOTE: Jitter at the NNI is the combination of the jitter generated and transferred via the client layers.

Activation: The function shall access the access point when it is activated (MI_Active is true). Otherwise, it shall not access the access point.

Defects: None.

Consequent Actions: None.

Defect Correlations: None.

Performance Monitoring: None.

13.3.2 E12 to P12x Adaptation Sink E12/P12x_A_Sk

Symbol:

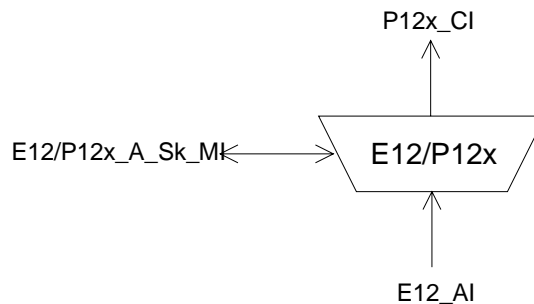

Figure 75: E12/P12x_A_Sk symbol

Interfaces:

Table 50: E12/P12x_A_Sk input and output signals

Input(s)	Output(s)
E12_AI_D	P12x_CI_D
E12_AI_TSF	P12x_CI_CK
E12/P12x_A_Sk_MI_Active	P12x_CI_SSF

Processes:

This function regenerates the received signal, recovers bit timing (CK) from the received signal, and decodes the incoming electrical 2 048 kbit/s E12 signal.

Regeneration: The function shall operate without any errors when any combination of the following signal conditions exist at the input:

- an input electrical amplitude level with any value in the range specified by ETS 300 166 [4];
- jitter modulation applied to the input signal with any value defined in ITU-T Recommendation G.823 [15];
- the input signal bit rate has any value in the range 2 048 kbit/s \pm 50 ppm;
- the input signal has an interfering signal specified by ETS 300 166 [4];
- for the case of a 120 Ω interface, the input signal has an longitudinal voltage specified by ETS 300 166 [4].

NOTE: The frequency and jitter / wander tolerance might be further constrained by the requirements of the client layers.

HDB3 decoding: The function shall perform the HDB3 decoding process specified by ETS 300 166 [4].

Activation: The function shall perform the operation specified above when it is activated (MI_Active is true). Otherwise, it shall transmit the all-ONES signal at its output (CI_D) and not report its status via the management point.

Defects: None.

Consequent Actions:

aSSF \leftarrow AI_TSF.

aAIS \leftarrow AI_TSF.

On declaration of aAIS the function shall output an all-ONES (AIS) signal - complying to the frequency limits for this interface (e.g. 2 048 kHz \pm 50 ppm, or nominal frequency) - within 250 μ s; on clearing of aAIS the function shall output normal data within 250 μ s.

Defect Correlations: None.

Performance Monitoring: None.

13.3.3 E12 to P12s Adaptation Source E12/P12s_A_So

Symbol:

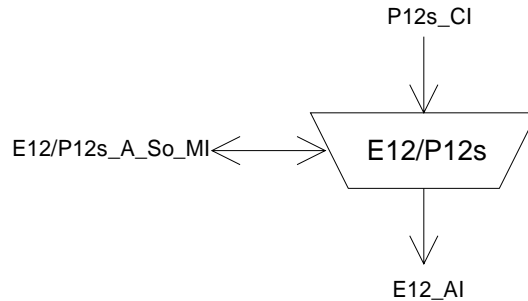

Figure 76: E12/P12s_A_So symbol

Interfaces:

Table 51: E12/P12s_So input and output signals

Input(s)	Output(s)
P12s_CI_D P12s_CI_CK E12/P12s_A_So_MI_Active	E12_AI_D

Processes:

This function provides HDB3 encoding of the 2 048 kbit/s P12s signal specified by ETS 300 166 [4].

HDB3 encoder: The function shall perform HDB3 encoding of the data as specified in ETS 300 166 [4].

The function shall not add any jitter.

NOTE: Jitter at the NNI is the combination of the jitter generated and transferred via the client layers.

Activation: The function shall access the access point when it is activated (MI_Active is true). Otherwise, it shall not access the access point.

Defects: None.

Consequent Actions: None.

Defect Correlations: None.

Performance Monitoring: None.

13.3.4 E12 to P12s Adaptation Sink E12/P12s_A_Sk

Symbol:

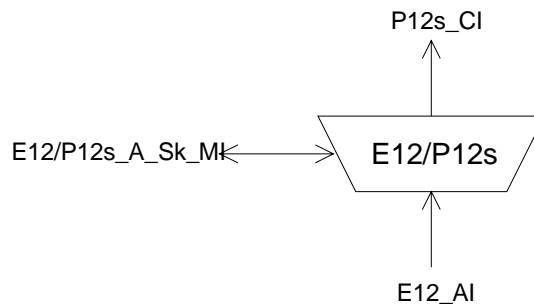

Figure 77: E12/P12s_A_Sk symbol

Interfaces:

Table 52: E12/P12s_Sk input and output signals

Input(s)	Output(s)
E12_AI_D	P12s_CI_D
	P12s_CI_CK
	P12s_CI_FS
E12_AI_TSF	P12s_CI_MFS
	P12s_CI_SSF
	P12s_CI_MFP
E12/P12s_A_Sk_MI_AIS_Reported	E12/P12s_A_Sk_MI_cLOF
E12/P12s_A_Sk_MI_Active	E12/P12s_A_Sk_MI_cAIS
E12/P12s_A_Sk_MI_CRC4mode	E12/P12s_A_Sk_MI_NCI

Processes:

The function regenerates the received signal, recovers bit timing (CK), decodes the incoming electrical 2 048 kbit/s E12 signal, and recovers Frame Start reference (FS).

Regeneration: The function shall operate without any errors when any combination of the following signal conditions exist at the input:

- an input electrical amplitude level with any value in the range specified by ETS 300 166 [4];
- jitter modulation applied to the input signal with any value defined in ITU-T Recommendation G.823 [15];
- the input signal bit rate has any value in the range 2 048 kbit/s \pm 50 ppm;
- the input signal has an interfering signal specified by ETS 300 166 [4];
- for the case of a 120 Ω interface, the input signal has an longitudinal voltage applied as specified by ETS 300 166 [4].

NOTE 1: The frequency and jitter / wander tolerance might be further constrained by the requirements of the client layers.

HDB3 decoding: The function shall perform the HDB3 decoding process specified by ETS 300 166 [4].

Basic frame and CRC-4 Multiframe alignment: The function shall recover the (250 μ s) basic frame and (2 ms) CRC-4 multiframe phase. The process shall operate as specified in ITU-T recommendation G.706 [11]. Either the manual, or the automatic, or both manual and automatic interworking modes shall be supported.

NOTE 2: The frame alignment process in ITU-T recommendation G.706 [11] is under study.

The process shall generate a multiframe present signal (CI_MFP) according the following rules:

- CI_MFP shall be FALSE when the CRC4mode is OFF.
- CI_MFP shall be FALSE when the CRC4mode is ON and the frame alignment process has not yet found multiframe alignment. CI_MFP shall be TRUE when multiframe alignment has been found.
- CI_MFP shall be FALSE when the CRC4mode is AUTO and the frame alignment process is in the states out-of-primary-BFA, in-primary-BFA, CRC-4 MFA search, assume-crc-to-non-crc-interworking. CI_MFP shall be TRUE if the frame alignment process is in the state assume-crc-to-crc-interworking..

Activation: The function shall perform the operation specified above when it is activated (MI_Active is true). Otherwise, it shall transmit the all-ONEs signal at its output (CI_D) and not report its status via the management point.

Defects:

The function shall detect dLOF defect as specified by ITU-T recommendation G.706 [11].

The function shall clear dLOF defect as specified by ITU-T recommendation G.706 [11].

The function shall report NCI status in the automatic CRC-4 interworking mode as specified by ITU-T recommendation G.706 [11].

The dAIS defect shall be detected specified by EN 300 417-1-1 [8], subclause 8.2.1.7 for 2 Mbit/s, with X = 2, Y = 512, Z = 3.

Consequent Actions:

aAIS ← dAIS or dLOF or AI_TSF.

aSSF ← dAIS or dLOF or AI_TSF.

On declaration of aAIS the function shall output an all-ONEs (AIS) signal - complying to the frequency limits for this interface - within 2 ms; on clearing of aAIS the function shall output normal data within 2 ms.

Defect Correlations:

cAIS ← dAIS and (not AI_TSF) and AIS_Reported.

cLOF ← dLOF and (not dAIS) and (not AI_TSF).

Performance Monitoring: None.

14 T12 Section Layer Functions

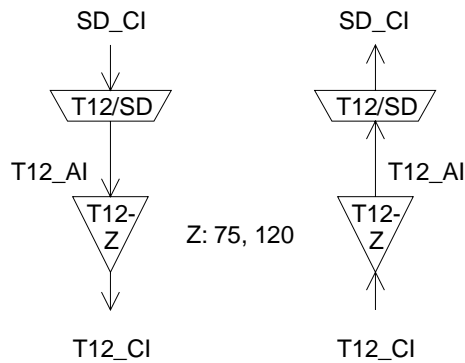

Figure 78: T12 Section atomic functions

T12 layer CP

The Characteristic Information T12_CI of the intra-station electrical layer CP is an electrical 2 048 kHz signal of defined amplitude, frequency and pulse shape specified by ETS 300 166 [4].

T12 layer AP

The information passing across the T12/SD AP is a 2 048 kHz synchronization signal.

14.1 T12 Connection function T12_C

Not applicable.

14.2 T12 Trail Termination functions

14.2.1 T12 Trail Termination Source T12-Z_TT_So

NOTE 1: Z (Ω) will be one value out of the set: {75, 120} (Ω).

Symbol:

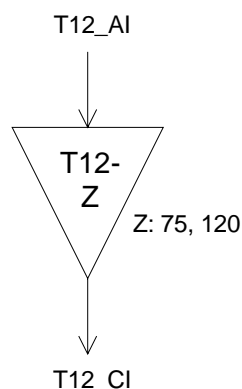

Figure 79: T12-Z_TT_So symbol

Interfaces:**Table 53: T12_TT_So input and output signals**

Input(s)	Output(s)
T12_AI_CK T12_AI_SQLCH	T12_CI_CK

Processes:

This function generates the electrical 2 048 kHz signal used for transmission of synchronization signals to an external equipment on a plesiochronous intra-station section specified by ETS 300 166 [4].

Pulse shape: The function shall meet the requirement specified by ETS 300 166 [4].

Maximum Peak Voltage: The function shall meet the requirement specified by ETS 300 166 [4].

Minimum peak voltage: The function shall meet the requirement specified by ETS 300 166 [4].

Pair in each direction: The function shall meet the requirement specified by ETS 300 166 [4].

Defects: None.

Consequent Actions:

On activation of T12_AI_SQLCH the function shall shutdown the output within 250 µs; on clearing of T12_AI_SQLCH the function shall output normal signal within 250 µs.

NOTE 2: For more details refer to EN 300 417-6-1 [9].

Defect Correlations: None.

Performance Monitoring: None.

14.2.2 T12 Trail Termination Sink T12-Z_TT_Sk

NOTE 1: Z (Ω) will be one value out of the set: {75, 120} (Ω).

Symbol:

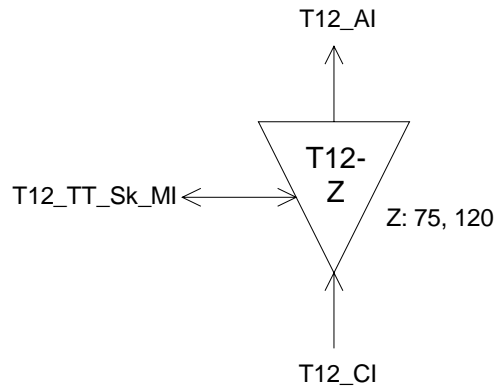

Figure 80: T12-Z_TT_Sk symbol

Interfaces:

Table 54: T12_TT_Sk input and output signals

Input(s)	Output(s)
T12_CI_CK	T12_AI_CK T12_AI_TSF
T12_TT_Sk_MI_PortMode	T12_TT_Sk_MI_cLOS

Processes:

This function recovers the electrical 2 048 kHz signal used for transmission of synchronization signals from an external equipment on a plesiochronous intra-station section specified by ETS 300 166 [4].

Input return loss: The function shall meet the requirement specified by ETS 300 166 [4].

Port Mode: The function shall have a port mode as specified by subclause 8.5 of EN 300 417-1-1 [8].

NOTE 2: The AUTO state of the port mode process is optional.

Defects:

The function shall detect 2 048 kHz Loss Of Signal defect (dLOS) as defined for the 2 048 kbit/s dLOS specification in subclause 8.2.1.6 of EN 300 417-1-1 [8].

Consequent Actions:

aTSF ← dLOS.

Defect Correlations:

cLOS ← MON and dLOS.

Performance Monitoring: None.

14.3 T12 Adaptation functions

14.3.1 T12 to SD Adaptation Source T12/SD_A_So

Refer to EN 300 417-6-1 [9].

14.3.2 T12 to SD Adaptation Sink T12/SD_A_Sk

Refer to EN 300 417-6-1 [9].

15 E0 Section Layer Functions

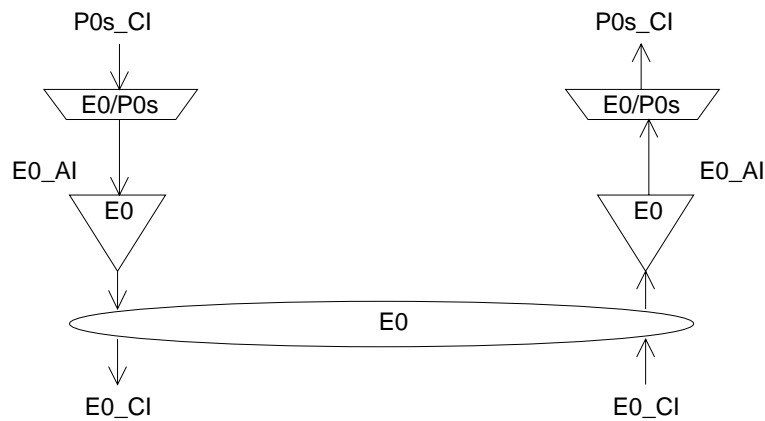

Figure 81: E0 Section atomic functions

E0 layer CP

The Characteristic Information E0_CI of the intra-station electrical layer CP is a digital, electrical 64 kbit/s co-directional signal set of defined amplitude, bit rate and pulse shape specified by ETS 300 166 [4].

E0 layer AP

The information passing across the E0/P0s AP is a synchronous 64 kbit/s signal with co-directional bit timing and octet identification.

15.1 E0 Connection function E0_C

For further study.

15.2 E0 Trail Termination functions

15.2.1 E0 Trail Termination Source E0_TT_So

Symbol:

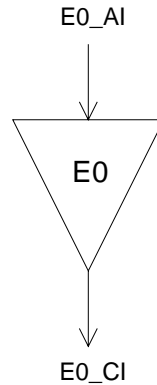

Figure 82: E0_TT_So symbol

Interfaces:

Table 55: E0_TT_So input and output signals

Input(s)	Output(s)
E0_AI_D	E0_CI_D

Processes:

This function generates the electrical 64 kbit/s co-directional Intra-station Section Layer signal E0 specified by ETS 300 166 [4].

Pulse shapes: The function shall meet the requirement specified by ETS 300 166 [4].

Peak to Peak Voltage: The function shall meet the requirement specified by ETS 300 166 [4].

Peak voltage of a space (no pulse): The function shall meet the requirement specified by ETS 300 166 [4].

Nominal pulse width: The function shall meet the requirement specified by ETS 300 166 [4].

Ratio of the amplitudes of positive and negative pulses at the centre of the pulse interval: The function shall meet the requirement specified by ETS 300 166 [4].

Ratio of widths of positive and negative pulses at the nominal half amplitude: The function shall meet the requirement specified by ETS 300 166 [4].

Pair(s) in each direction: The function shall meet the requirement specified by ETS 300 166 [4].

Output signal balance: The function shall meet the requirement specified by ETS 300 166 [4].

Output return loss: The function shall meet the requirement specified by ETS 300 166 [4].

Defects: None.

Consequent Actions: None.

Defect Correlations: None.

Performance Monitoring: None.

15.2.2 E0 Trail Termination Sink E0_TT_Sk

Symbol:

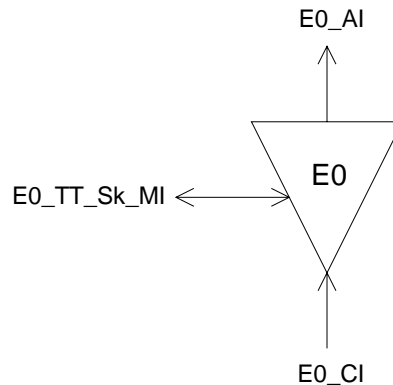

Figure 83: E0_TT_Sk symbol

Interfaces:

Table 56: E0_TT_Sk input and output signals

Input(s)	Output(s)
E0_CI_D	E0_AI_D E0_AI_TSF
E0_TT_Sk_MI_PortMode	E0_TT_Sk_MI_cLOS

Processes:

This function recovers the electrical Intra-station Section Layer signal E0 specified by ETS 300 166 [4].

Input return loss: The function shall meet the requirement specified by ETS 300 166 [4].

Impedance towards ground: The function shall meet the requirement specified by ETS 300 166 [4].

Port Mode: The function shall have a port mode as specified by subclause 8.5 of EN 300 417-1-1 [8].

NOTE 1: The AUTO state of the port mode process is optional.

Defects:

The function shall detect a Loss Of Signal defect (dLOS) according the 64 kbit/s dLOS specification in subclause 8.2.1.6 of EN 300 417-1-1 [8].

NOTE 2: An E0 interface used for OW or User Channel does not need to be monitored for loss of signal.

Consequent Actions:

aTSF ← dLOS.

Defect Correlations:

cLOS ← MON and dLOS.

Performance Monitoring: None.

15.3 E0 Adaptation functions

15.3.1 E0 to P0s Adaptation Source E0/P0s_A_So

Symbol:

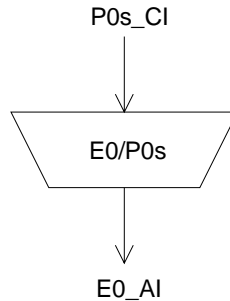

Figure 84: E0/P0s_A_So symbol

Interfaces:

Table 57: E0/P0s_A_So input and output signals

Input(s)	Output(s)
P0s_CI_D P0s_CI_CK P0s_CI_FS	E0_AI_D

Processes:

This function provides the encoding of the co-directional 64 kbit/s information stream specified by ETS 300 166 [4].

Encoder: The function shall perform encoding of the data as specified in ETS 300 166 [4].

The function shall not add any jitter.

NOTE: Jitter at the NNI is the combination of the jitter generated and transferred via the client layers.

Defects: None.

Consequent Actions: None.

Defect Correlations: None.

Performance Monitoring: None.

15.3.2 E0 to P0s Adaptation Sink E0/P0s_A_Sk

Symbol:

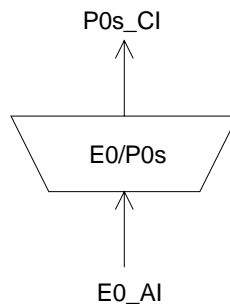

Figure 85: E0/P0s_A_Sk symbol

Interfaces:

Table 58: E0/P0s_A_Sk input and output signals

Input(s)	Output(s)
E0_AI_D E0_AI_TSF	P0s_CI_D P0s_CI_CK P0s_CI_FS P0s_CI_SSF

Processes:

This function regenerates the received signal, recovers bit timing (CK) and octet timing from the received signal, and decodes the incoming electrical co-directional 64 kbit/s E0 signal.

Regeneration: The function shall operate without any errors when any combination of the following signal conditions exist at the input:

- an input electrical amplitude level with any value in the range specified by ETS 300 166 [4];
- jitter modulation applied to the input signal with any value defined in ITU-T Recommendation G.823 [15];
- the input signal bit rate has any value in the range 64 kbit/s \pm 100 ppm;
- the input signal has an interfering signal specified by ETS 300 166 [4];
- the input signal has a longitudinal voltage applied as specified by ETS 300 166 [4].

NOTE 1: The frequency and jitter / wander tolerance might be further constrained by the requirements of the client layers.

Decoding and octet alignment: The function shall perform the decoding and octet alignment processes as specified in ETS 300 166 [4] for 64 kbit/s co-directional interfaces.

Defects:

None.

NOTE 2: The addition of a Loss of Octet Timing defect (dLOT) is for further study.

Consequent Actions:

aAIS ← AI_TSF.

aSSF ← AI_TSF.

On declaration of aAIS the function shall output an all-ONEs (AIS) signal - complying to the frequency limits for this interface (e.g. 64 kHz \pm 100 ppm, or nominal frequency) - within 250 μ s; on clearing of aAIS the function shall output normal data within 250 μ s.

Defect Correlations: None.

Performance Monitoring: None.

Annex A (informative): E32 Section Layer Functions

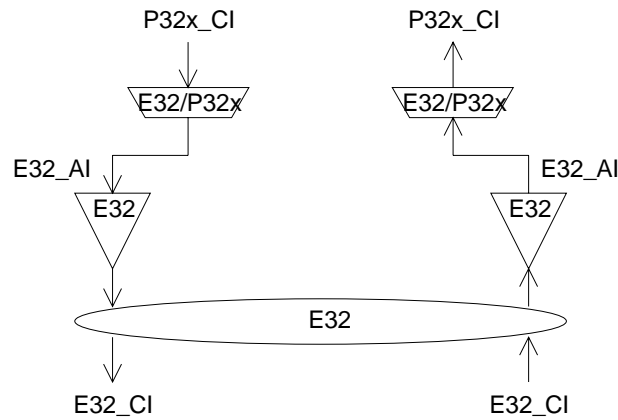

Figure A.1: E32 Section atomic functions

E32 layer CP

The Characteristic Information E32_CI of the intra-station electrical layer CP is a digital, electrical signal of defined amplitude, bit rate and pulse shape specified by ANSI T1.102 [1].

NOTE: The pulse shape defined in ANSI T1.102 [1] is for the signal at the digital distribution frame, not at the connector of the equipment.

E32 layer AP

The information passing across the E32/P32x AP is a 44 736 kbit/s signal with co-directional bit timing.

A.1 E32 Connection function E32_C

For further study.

A.2 E32 Trail Termination functions

A.2.1 E32 Trail Termination Source E32_TT_So

Symbol:

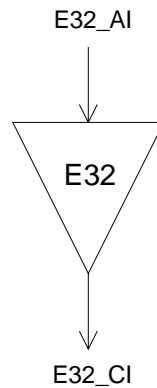

Figure A.2: E32_TT_So symbol

Interfaces:

Table A.1: E32_TT_So input and output signals

Input(s)	Output(s)
E32_AI_D	E32_CI_D

Processes:

This function generates the electrical Intra-station Section Layer signal E32 specified by ANSI T1.102 [1].

The function shall meet the *medium, pulse amplitude, pulse shape, power level, pulse imbalance and DC power* requirements specified by ANSI T1.102 [1].

Defects: None.

Consequent Actions: None.

Defect Correlations: None.

Performance Monitoring: None.

A.2.2 E32 Trail Termination Sink E32_TT_Sk

Symbol:

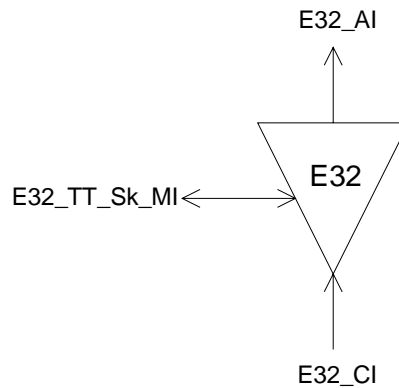

Figure A.3: E32_TT_Sk symbol

Interfaces:

Table A.2: E32_TT_Sk input and output signals

Input(s)	Output(s)
E32_CI_D	E32_AI_D E32_AI_TSF
E32_TT_Sk_MI_PortMode	E32_TT_Sk_MI_cLOS

Processes:

This function recovers the electrical Intra-station Section Layer signal E32 specified by ANSI T1.102 [1].

Port Mode: The function shall have a port mode as specified by subclause 8.5 of EN 300 417-1-1 [8].

NOTE: The AUTO state of the port mode process is optional.

Defects:

The function shall detect Loss Of Signal defect (dLOS) according the 44 736 kbit/s dLOS specification in ITU-T Recommendation G.775 [14].

Consequent Actions:

aTSF ← dLOS.

Defect Correlations:

cLOS ← MON and dLOS.

Performance Monitoring: None.

A.3 E32 Adaptation functions

A.3.1 E32 to P32x Adaptation Source E32/P32x_A_So

Symbol:

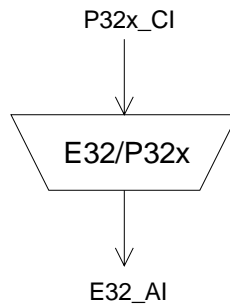

Figure A.4: E32/P32x_A_So symbol

Interfaces:

Table A.3: E32/P32x_A_So input and output signals

Input(s)	Output(s)
P32x_CI_D P32x_CI_CK	E32_AI_D

Processes:

This function provides the B3ZS encoding of the 44 736 kbit/s information stream specified by CCITT Recommendation G.703 [10].

B3ZS encoder: The function shall perform B3ZS encoding of the data specified by ANSI T1.102 [1].

The function shall not add any jitter.

NOTE: Jitter at the NNI is the combination of the jitter generated and transferred via the client layers.

Defects: None.

Consequent Actions: None.

Defect Correlations: None.

Performance Monitoring: None.

A.3.2 E32 to P32x Adaptation Sink E32/P32x_A_Sk

Symbol:

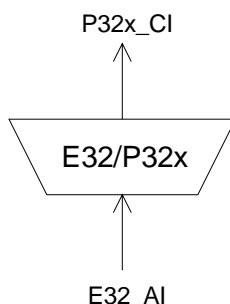

Figure A.5: E32/P32x_A_Sk symbol

Interfaces:

Table A.4: E32/P32x_A_Sk input and output signals

Input(s)	Output(s)
E32_AI_D E32_AI_TSF	P32x_CI_D P32x_CI_CK P32x_CI_SSF

Processes:

This function regenerates the received signal, recovers bit timing (CK) from the received signal, and decodes the incoming electrical 44 736 kbit/s E32 signal.

Regeneration: The function shall operate without any errors when any combination of the following signal conditions exist at the input:

- an input electrical amplitude level with any value in the range specified by ANSI T1.102 [1];
- jitter modulation applied to the input signal with any value specified by ANSI T1.102 [1];
- the input signal bit rate has any value in the range 44 736 kbit/s \pm 20 ppm.

NOTE: The frequency and jitter / wander tolerance might be further constrained by the requirements of the client layers.

B3ZS decoding: The function shall perform the B3ZS decoding process specified by ANSI T1.102 [1].

Defects: None.

Consequent Actions:

aSSF \leftarrow AI_TSF.

aAIS \leftarrow AI_TSF.

On declaration of aAIS the function shall output an AIS signal (see below for definition) - complying to the frequency limits for this interface - within 250 μ s; on clearing of aAIS the function shall output normal data within 250 μ s.

The AIS signal for this interface (as specified by ANSI T1.107 [2]) is a signal with valid M-frame alignment channel, M-subframe alignment channel and valid P bits. The information bits are set to a "10" sequence starting with a "1" after each M-frame alignment bit, X-bit, P-bit, and C-bit channel. The C-bits are set to "0". The X-bits are set to "1".

Defect Correlations: None.

Performance Monitoring: None.

Annex B (informative): E11 Section Layer Functions

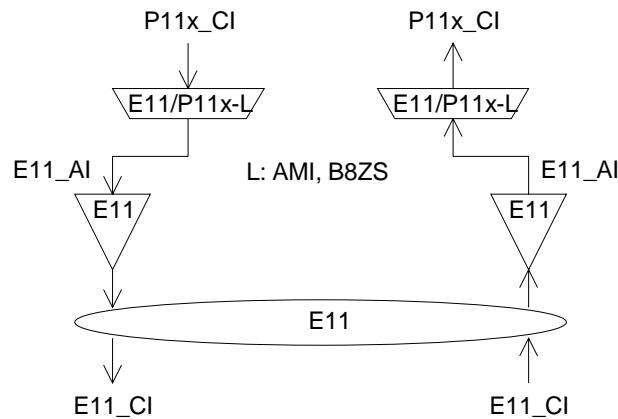

Figure B.1: E11 Section atomic functions

E11 layer CP

The Characteristic Information E11_CI of the intra-station electrical layer CP is a digital, electrical 1 544 kbit/s signal of defined amplitude, bit rate and pulse shape specified by ANSI T1.102 [1].

NOTE: The pulse shape defined in ANSI T1.102 [1] is for the signal at the digital distribution frame, not at the connector of the equipment.

E11 layer AP

The information passing across the E11/P11x AP is a 1 544 kbit/s signal with co-directional bit timing.

B.1 E11 Connection function E11_C

For further study.

B.2 E11 Trail Termination functions

B.2.1 E11 Trail Termination Source E11_TT_So

Symbol:

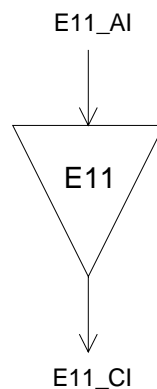

Figure B.2: E11_TT_So symbol

Interfaces:**Table B.1: E11_TT_So input and output signals**

Input(s)	Output(s)
E11_AI_D	E11_CI_D

Processes:

This function generates the electrical 1 544 kbit/s Intra-station Section Layer signal E11 specified by ANSI T1.102 [1].

The function shall meet the *medium, pulse amplitude, pulse shape, power level, pulse imbalance and DC power* requirements specified by ANSI T1.102 [1].

Defects: None.

Consequent Actions: None.

Defect Correlations: None.

Performance Monitoring: None.

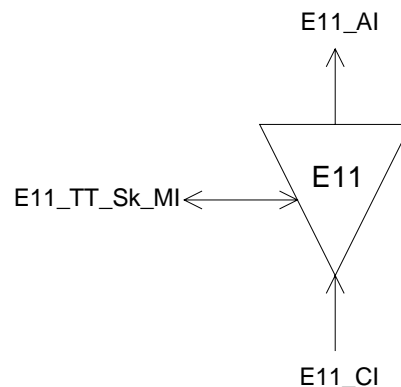
B.2.2 E11 Trail Termination Sink E11_TT_Sk**Symbol:****Figure B.3: E11_TT_Sk symbol****Interfaces:****Table B.2: E11_TT_Sk input and output signals**

Input(s)	Output(s)
E11_CI_D	E11_AI_D E11_AI_TSF
E11_TT_Sk_MI_PortMode	E11_TT_Sk_MI_cLOS

Processes:

This function recovers the electrical 1 544 kbit/s Intra-station Section Layer signal E11 specified by ANSI T1.102 [1].

Port Mode: The function shall have a port mode as specified by subclause 8.5 of EN 300 417 -1-1 [8].

NOTE: The AUTO state of the port mode process is optional.

Defects:

The function shall detect Loss Of Signal defect (dLOS) according the 1 544 kbit/s dLOS specification in ITU-T Recommendation G.775 [14].

Consequent Actions:

aTSF ← dLOS.

Defect Correlations:

cLOS ← MON and dLOS.

Performance Monitoring: None.

B.3 E11 Adaptation functions

B.3.1 E11 to P11x Adaptation Source E11/P11x-L_A_So

NOTE 1: L will be one value out of the set: {AMI, B8ZS}.

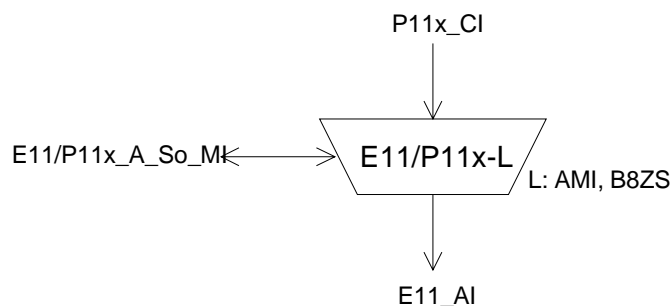
Symbol:**Figure B.4: E11/P11x-L_A_So symbol****Interfaces:****Table B.3: E11/P11x-L_A_So input and output signals**

Input(s)	Output(s)
P11x_CI_D P11x_CI_CK E11/P11x_A_So_MI_Active	E11_AI_D

Processes:

This function provides the line encoding of the 1 544 kbit/s information stream specified by ANSI T1.102 [1].

Line encoder: The function shall perform line encoding of the data as specified ANSI T1.102 [1].

The function shall not add any jitter.

NOTE 2: Jitter at the NNI is the combination of the jitter generated and transferred via the client layers.

Defects: None.**Consequent Actions:** None.**Defect Correlations:** None.**Performance Monitoring:** None.

B.3.2 E11 to P11x Adaptation Sink E11/P11x-L_A_Sk

NOTE 1: L will be one value out of the set: {AMI, B8ZS}.

Symbol:

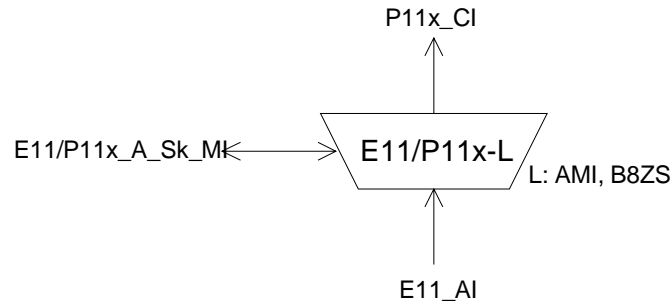

Figure B.5: E11/P11x_A_Sk symbol

Interfaces:

Table B.4: E11/P11x_A_Sk input and output signals

Input(s)	Output(s)
E11_AI_D	P11x_CI_D
E11_AI_TSF	P11x_CI_CK
E11/P11x_A_Sk_MI_Active	P11x_CI_SSF

Processes:

This function regenerates the received signal, recovers bit timing (CK) from the received signal, and decodes the incoming electrical 1 544 kbit/s E11 signal. It supplies the recovered timing signal to the synchronization distribution layer.

Regeneration: The function shall operate without any errors when any combination of the following signal conditions exist at the input:

- an input electrical amplitude level with any value in the range specified by ANSI T1.102 [1];
- jitter modulation applied to the input signal with any value specified by ANSI T1.102 [1];
- the input signal bit rate has any value in the range 1 544 kbit/s \pm 50 ppm.

NOTE 2: The frequency and jitter / wander tolerance might be further constrained by the requirements of the client layers.

Line decoding: The function shall perform the line decoding process specified by ANSI T1.102 [1].

Defects: None.

Consequent Actions:

aSSF \leftarrow AI_TSF.

aAIS \leftarrow AI_TSF.

On declaration of aAIS the function shall output an all-ONES (AIS) signal - complying to the frequency limits for this interface (e.g. 1 544 kHz \pm 50 ppm) - within 250 μ s; on clearing of aAIS the function shall output normal data within 250 μ s.

Defect Correlations: None.

Performance Monitoring: None.

Annex C (informative): Bibliography

The following material, though not specifically referenced in the body of the present document (or not publicly available), gives supporting information.

ITU-T Recommendation V.11 (1993): "Electrical characteristics for balanced double-current interchange circuits operating at data signalling rates up to 10 Mbit/s".

EN 300 462-3-1: "Transmission and Multiplexing (TM); Generic requirements for synchronization networks; Part 3-1: The control of jitter and wander within synchronization networks".

ITU-T Recommendation G.664: "Optical safety procedures and requirements for optical transport systems".

History

Document history		
Edition 1	April 1997	Publication as ETS
V1.1.2	November 1998	Publication
V1.1.3	May 1999	Publication
V1.2.1	June 2001	One-step Approval Procedure OAP 20011012: 2001-06-13 to 2001-10-12