

EN 300 417-2-1 V1.1.3 (1999-05)

European Standard (Telecommunications series)

**Transmission and Multiplexing (TM);
Generic requirements of transport functionality of equipment;
Part 2-1: Synchronous Digital Hierarchy (SDH) and
Plesiochronous Digital Hierarchy (PDH)
physical section layer functions**



Reference

REN/TM-01015-2-1a (3v0i9ie0.PDF)

Keywords

SDH, transmission, interface

ETSI

Postal address

F-06921 Sophia Antipolis Cedex - FRANCE

Office address

650 Route des Lucioles - Sophia Antipolis
Valbonne - FRANCE
Tel.: +33 4 92 94 42 00 Fax: +33 4 93 65 47 16
Siret N° 348 623 562 00017 - NAF 742 C
Association à but non lucratif enregistrée à la
Sous-Préfecture de Grasse (06) N° 7803/88

Internet

secretariat@etsi.fr
Individual copies of this ETSI deliverable
can be downloaded from
<http://www.etsi.org>
If you find errors in the present document, send your
comment to: editor@etsi.fr

Copyright Notification

No part may be reproduced except as authorized by written permission.
The copyright and the foregoing restriction extend to reproduction in all media.

© European Telecommunications Standards Institute 1999.
All rights reserved.

Contents

Intellectual Property Rights	6
Foreword	6
1 Scope	8
2 References	8
3 Definitions, abbreviations and symbols	9
3.1 Definitions	9
3.2 Abbreviations	9
3.3 Symbols and diagrammatic conventions	14
3.4 Introduction	14
4 STM-1 Optical Section Layer Functions	14
4.1 Optical Section Connection functions	15
4.2 Optical Section Trail Termination functions	15
4.2.1 Optical Section Trail Termination Source OS1-Xy.z_TT_So	15
4.2.2 Optical Section Trail Termination Sink OS1-Xy.z_TT_Sk	17
4.3 Optical Section Adaptation functions	18
4.3.1 Optical Section to Regenerator Section Adaptation Source OS1/RS1_A_So	18
4.3.2 Optical Section to Regenerator Section Adaptation Sink OS1/RS1_A_Sk	19
5 STM-4 Optical Section Layer Functions	21
5.1 Optical Section Connection functions	21
5.2 Optical Section Trail Termination functions	22
5.2.1 Optical Section Trail Termination Source OS4-Xy.z_TT_So	22
5.2.2 Optical Section Trail Termination Sink OS4-Xy.z_TT_Sk	23
5.3 Optical Section Adaptation functions	24
5.3.1 Optical Section to Regenerator Section Adaptation Source OS4/RS4_A_So	24
5.3.2 Optical Section to Regenerator Section Adaptation Sink OS4/RS4_A_Sk	25
6 STM-16 Optical Section Layer Functions	27
6.1 Optical Section Connection functions	28
6.2 Optical Section Trail Termination functions	28
6.2.1 Optical Section Trail Termination Source OS16-Xy.z_TT_So	28
6.2.2 Optical Section Trail Termination Sink OS16-Xy.z_TT_Sk	29
6.3 Optical Section Adaptation functions	30
6.3.1 Optical Section to Regenerator Section Adaptation Source OS16/RS16_A_So	30
6.3.2 Optical Section to Regenerator Section Adaptation Sink OS16/RS16_A_Sk	31
7 STM-64 Optical Section Layer Functions	33
8 STM-1 Electrical Section Layer Functions	33
8.1 STM-1 Electrical Section Connection function ES1_C	33
8.2 STM-1 Electrical Section Trail Termination functions	34
8.2.1 STM-1 Electrical Section Trail Termination Source ES1_TT_So	34
8.2.2 STM-1 Electrical Section Trail Termination Sink ES1_TT_Sk	35
8.3 STM-1 Electrical Section Adaptation functions	36
8.3.1 STM-1 Electrical Section to Regenerator Section Adaptation Source ES1/RS1_A_So	36
8.3.2 STM-1 Electrical Section to Regenerator Section Adaptation Sink ES1/RS1_A_Sk	37
9 E4 Section Layer Functions	39
9.1 E4 Connection function E4_C	40
9.2 E4 Trail Termination functions	40
9.2.1 E4 Trail Termination Source E4_TT_So	40
9.2.2 E4 Trail Termination Sink E4_TT_Sk	42
9.3 E4 Adaptation functions	43
9.3.1 E4 to P4x Adaptation Source E4/P4x_A_So	43
9.3.2 E4 to P4x Adaptation Sink E4/P4x_A_Sk	44
9.3.3 E4 to P4e Adaptation Source E4/P4e_A_So	45

9.3.4	E4 to P4e Adaptation Sink E4/P4e_A_Sk.....	46
9.3.5	E4 to P4s Adaptation Source E4/P4s_A_So.....	48
9.3.6	E4 to P4s Adaptation Sink E4/P4s_A_Sk.....	49
10	E31 Section Layer Functions.....	51
10.1	E31 Connection function E31_C.....	52
10.2	E31 Trail Termination functions.....	52
10.2.1	E31 Trail Termination Source E31_TT_So.....	52
10.2.2	E31 Trail Termination Sink E31_TT_Sk.....	54
10.3	E31 Adaptation functions.....	55
10.3.1	E31 to P31x Adaptation Source E31/P31x_A_So.....	55
10.3.2	E31 to P31x Adaptation Sink E31/P31x_A_Sk.....	56
10.3.3	E31 to P31e Adaptation Source E31/P31e_A_So.....	57
10.3.4	E31 to P31e Adaptation Sink E31/P31e_A_Sk.....	58
10.3.5	E31 to P31s Adaptation Source E31/P31s_A_So.....	60
10.3.6	E31 to P31s Adaptation Sink E31/P31s_A_Sk.....	61
11	E22 Section Layer Functions.....	63
11.1	E22 Connection function E22_C.....	63
11.2	E22 Trail Termination functions.....	64
11.2.1	E22 Trail Termination Source E22_TT_So.....	64
11.2.2	E22 Trail Termination Sink E22_TT_Sk.....	65
11.3	E22 Adaptation functions.....	66
11.3.1	E22 to P22x Adaptation Source E22/P22x_A_So.....	66
11.3.2	E22 to P22x Adaptation Sink E22/P22x_A_Sk.....	67
11.3.3	E22 to P22e Adaptation Source E22/P22e_A_So.....	68
11.3.4	E22 to P22e Adaptation Sink E22/P22e_A_Sk.....	69
12	E12 Section Layer Functions.....	71
12.1	E12 Connection function E12_C.....	72
12.2	E12 Trail Termination functions.....	73
12.2.1	E12 Trail Termination Source E12-Z_TT_So.....	73
12.2.2	E12 Trail Termination Sink E12-Z_TT_Sk.....	74
12.3	E12 Adaptation functions.....	75
12.3.1	E12 to P12x Adaptation Source E12/P12x_A_So.....	75
12.3.2	E12 to P12x Adaptation Sink E12/P12x_A_Sk.....	76
12.3.3	E12 to P12s Adaptation Source E12/P12s_A_So.....	77
12.3.4	E12 to P12s Adaptation Sink E12/P12s_A_Sk.....	78
13	T12 Section Layer Functions.....	80
13.1	T12 Connection function T12_C.....	80
13.2	T12 Trail Termination functions.....	80
13.2.1	T12 Trail Termination Source T12-Z_TT_So.....	80
13.2.2	T12 Trail Termination Sink T12-Z_TT_Sk.....	82
13.3	T12 Adaptation functions.....	83
13.3.1	T12 to SD Adaptation Source T12/SD_A_So.....	83
13.3.2	T12 to SD Adaptation Sink T12/SD_A_Sk.....	83
14	E0 Section Layer Functions.....	83
14.1	E0 Connection function E0_C.....	83
14.2	E0 Trail Termination functions.....	84
14.2.1	E0 Trail Termination Source E0_TT_So.....	84
14.2.2	E0 Trail Termination Sink E0_TT_Sk.....	85
14.3	E0 Adaptation functions.....	86
14.3.1	E0 to P0s Adaptation Source E0/P0s_A_So.....	86
14.3.2	E0 to P0s Adaptation Sink E0/P0s_A_Sk.....	87
Annex A (informative): E32 Section Layer Functions		89
A.1	E32 Connection function E32_C.....	89
A.2	E32 Trail Termination functions.....	89
A.2.1	E32 Trail Termination Source E32_TT_So.....	89

A.2.2	E32 Trail Termination Sink E32_TT_Sk.....	91
A.3	E32 Adaptation functions	92
A.3.1	E32 to P32x Adaptation Source E32/P32x_A_So	92
A.3.2	E32 to P32x Adaptation Sink E32/P32x_A_Sk.....	93
Annex B (informative): E11 Section Layer Functions		94
B.1	E11 Connection function E11_C.....	94
B.2	E11 Trail Termination functions	94
B.2.1	E11 Trail Termination Source E11_TT_So.....	94
B.2.2	E11 Trail Termination Sink E11_TT_Sk.....	96
B.3	E11 Adaptation functions	97
B.3.1	E11 to P11x Adaptation Source E11/P11x-L_A_So	97
B.3.2	E11 to P11x Adaptation Sink E11/P11x-L_A_Sk.....	98
Bibliography		99
History.....		100

Intellectual Property Rights

IPRs essential or potentially essential to the present document may have been declared to ETSI. The information pertaining to these essential IPRs, if any, is publicly available for **ETSI members and non-members**, and can be found in SR 000 314: "*Intellectual Property Rights (IPRs); Essential, or potentially Essential, IPRs notified to ETSI in respect of ETSI standards*", which is available **free of charge** from the ETSI Secretariat. Latest updates are available on the ETSI Web server (<http://www.etsi.org/ipr>).

Pursuant to the ETSI IPR Policy, no investigation, including IPR searches, has been carried out by ETSI. No guarantee can be given as to the existence of other IPRs not referenced in SR 000 314 (or the updates on the ETSI Web server) which are, or may be, or may become, essential to the present document.

Foreword

This European Standard (Telecommunications series) has been produced by ETSI Technical Committee Transmission and Multiplexing (TM).

The present document is one of a family of documents that has been produced in order to provide inter-vendor and inter-operator compatibility of Synchronous Digital Hierarchy (SDH) equipment.

The present document is part 2-1 of a multi-part EN covering the generic requirements of transport functionality of equipment, as identified below:

Part 1-1: "Generic processes and performance".

Part 1-2: "General information about Implementation Conformance Statement (ICS) proforma".

Part 2-1: "Synchronous Digital Hierarchy (SDH) and Plesiochronous Digital Hierarchy (PDH) physical section layer functions".

Part 2-2: "Synchronous Digital Hierarchy (SDH) and Plesiochronous Digital Hierarchy (PDH) physical section layer functions; Implementation Conformance Statement (ICS) proforma specification".

Part 3-1: "Synchronous Transport Module-N (STM-N) regenerator and multiplex section layer functions".

Part 3-2: "Synchronous Transport Module-N (STM-N) regenerator and multiplex section layer functions; Implementation Conformance Statement (ICS) proforma specification".

Part 4-1: "Synchronous Digital Hierarchy (SDH) path layer functions".

Part 4-2: "Synchronous Digital Hierarchy (SDH) path layer functions; Implementation Conformance Statement (ICS) proforma specification".

Part 5-1: "Plesiochronous Digital Hierarchy (PDH) path layer functions".

Part 5-2: "Plesiochronous Digital Hierarchy (PDH) path layer functions; Implementation Conformance Statement (ICS) proforma specification".

Part 6-1: "Synchronization layer functions".

Part 6-2: "Synchronization layer functions; Implementation Conformance Statement (ICS) proforma specification".

Part 7-1: "Auxiliary layer functions".

Part 7-2: "Auxiliary layer functions; Implementation Conformance Statement (ICS) proforma specification".

Parts 2 to 7 specify the layers and their atomic functions.

NOTE 1: The present document does not currently address configuration management.

NOTE 2: The SDH radio equipment functional blocks are addressed by ETSI WG TM4.

Various of the above parts have previously been published as parts of ETS 300 417.

They have been converted into parts of EN 300 417 without technical changes, but some editorial changes have been necessary (e.g. references). In particular:

- Parts 2-1, 2-2 and 3-2 have been modified to take account of editorial errors present in edition 1.
- Part 1-1 has had its title change of to align with other parts published at a later date.

Also note that in the meantime parts 8-1 and 8-2 together with all parts x-3 (Abstract Test Suites) have been stopped.

This version of the present document has been published because the previous version had incorrect dates in the transposition table.

National transposition dates	
Date of latest announcement of this EN (doa):	31 August 1999
Date of latest publication of new National Standard or endorsement of this EN (dop/e):	29 February 2000
Date of withdrawal of any conflicting National Standard (dow):	29 February 2000

1 Scope

The present document specifies a library of basic building blocks and a set of rules by which they are combined in order to describe transport functionality of equipment. The library comprises the functional building blocks needed to completely specify the generic functional structure of the European transmission hierarchies. Equipment which is compliant with the present document needs to be describable as an interconnection of a subset of these functional blocks contained within the present document. The interconnections of these blocks need to obey the combination rules given. The generic functionality is described in the EN 300 417-1-1 [8].

2 References

The following documents contain provisions which, through reference in this text, constitute provisions of the present document.

- References are either specific (identified by date of publication, edition number, version number, etc.) or non-specific.
- For a specific reference, subsequent revisions do not apply.
- For a non-specific reference, the latest version applies.
- A non-specific reference to an ETS shall also be taken to refer to later versions published as an EN with the same number.

- [1] ANSI T1.102 (1993): "Telecommunications; Digital Hierarchy; Electrical Interfaces".
- [2] ANSI T1.107 (1988): "Telecommunications; Digital Hierarchy; Formats Specifications".
- [3] ETS 300 147: "Transmission and Multiplexing (TM); Synchronous Digital Hierarchy (SDH); Multiplexing structure".
- [4] ETS 300 166 (1993): "Transmission and Multiplexing (TM); Physical and electrical characteristics of hierarchical digital interfaces for equipment using the 2 048 kbit/s - based plesiochronous or synchronous digital hierarchies".
- [5] ETS 300 167: "Transmission and Multiplexing (TM); Functional characteristics of 2 048 kbit/s interfaces".
- [6] ETS 300 232 (1993): "Transmission and Multiplexing (TM); Optical interfaces for equipments and systems relating to the Synchronous Digital Hierarchy [ITU-T Recommendation G.957 (1993) modified]".
- [7] ETS 300 337: "Transmission and Multiplexing (TM); Generic frame structures for the transport of various signals (including Asynchronous Transfer Mode (ATM) cells and Synchronous Digital Hierarchy (SDH) elements) at the ITU-T Recommendation G.702 hierarchical rates of 2 048 kbit/s, 34 368 kbit/s and 139 264 kbit/s".
- [8] EN 300 417-1-1: "Transmission and Multiplexing (TM); Generic requirements of transport functionality of equipment; Part 1-1: Generic processes and performance".
- [9] EN 300 417-6-1: "Transmission and Multiplexing (TM); Generic requirements of transport functionality of equipment; Part 6-1: Synchronization distribution layer functions".
- [10] CCITT Recommendation G.703 (1991): "Physical/electrical characteristics of hierarchical digital interfaces".
- [11] CCITT Recommendation G.742 (1988): "Second order digital multiplex equipment operating at 8 448 kbit/s and using positive justification".

- [12] CCITT Recommendation G.751 (1988): "Digital multiplex equipments operating at the third order bit rate of 34 368 kbit/s and the fourth order bit rate of 139 264 kbit/s and using positive justification".
- [13] ITU-T Recommendation G.775 (1994): "Loss of signal (LOS) and alarm indication signal (AIS) defect detection and clearance criteria".
- [14] ITU-T Recommendation G.823 (1993): "The control of jitter and wander within digital networks which are based on the 2 048 kbit/s hierarchy".
- [15] ITU-T Recommendation G.825: "The control of jitter and wander within digital networks which are based on the synchronous digital hierarchy (SDH)".
- [16] ITU-T Recommendation G.958 (1994): "Digital line systems based on the synchronous digital hierarchy for use on optical fibre cables".

3 Definitions, abbreviations and symbols

3.1 Definitions

The functional definitions are described in EN 300 417-1-1 [8].

3.2 Abbreviations

For the purposes of the present document, the following abbreviations apply:

A	Adaptation function
AcSL	Accepted Signal Label
AcTI	Accepted Trace Identifier
ADM	Add-Drop Multiplexer
AI	Adapted Information
AIS	Alarm Indication Signal
ALS	Automatic Laser Shutdown
ANSI	American National Standards Institute
AP	Access Point
APId	Access Point Identifier
APS	Automatic Protection Switch
ATM	Asynchronous Transfer Mode
AU	Administrative Unit
AUG	Administrative Unit Group
AU-n	Administrative Unit, level n
BBE	Background Block Error
BBER	Background Block Error Ratio
BER	Bit Error Ratio
BFA	Basic Frame Alignment
BIP	Bit Interleaved Parity
BIP-N	Bit Interleaved Parity, width N
BITS	Building Integrated Timing Supply
BNF	Backus-Naur Form
BSHR	Bi-directional Self Healing Ring
C	Connection function
CH	CHannel
CI	Characteristic Information
CID	Consecutive Identical Digits
CK	ClocK
CM	Connection Matrix
CMI	Coded Mark Inversion
Co	Connection

CP	Connection Point
CRC	Cyclic Redundancy Check
CRC-N	Cyclic Redundancy Check, width N
Cs	supervisory-unequipped Connection function
CSES	Consecutive Severely Errored Seconds
CTF	Compound Timing Function
Ctrl	Control
D	Data
DCC	Data Communications Channel
DEC	DECrement
DEG	DEGraded
DEGTHR	DEGraded THReshold
DL	Data Link
DPRING	Dedicated Protection RING
DROP	Decreased Received Optical Power
DXC	Digital Cross Connect
E0	Electrical interface signal 64 kbit/s
E11	Electrical interface signal 1 544 kbit/s
E12	Electrical interface signal 2 048 kbit/s
E22	Electrical interface signal 8 448 kbit/s
E31	Electrical interface signal 34 368 kbit/s
E32	Electrical interface signal 44 736 kbit/s
E4	Electrical interface signal 139 264 kbit/s
EBC	Errored Block Count
ECC	Embedded Communications Channel
ECC(x)	Embedded Communications Channel, layer x
EDC	Error Detection Code
EDCV	Error Detection Code Violation
EFS	Equipment Functional Specification
EMF	Equipment Management Function
EPS	Equipment Protection Switch
EQ	EQuipment
ERS	Elementary Regenerator Section
ES	Electrical Section
ES	Errored Second
ESR	Errored Seconds Ratio
Ex	CCITT Recommendation G.703 [10] type electrical signal, bit rate order x
ExSL	Expected Signal Label
ExTI	Expected Trace Identifier
F_B	Far-end Block
F_BBE	Far-end Background Block Error
F_DS	Far-end Defect Second
F_EBC	Far-end Errored Block Count
F_ES	Far-end Errored Second
F_SES	Far-end Severely Errored Second
F_SESTHR	Far-end Severely Errored Second THReshold
F_UAT_cmd	Far-end UnAvailable Time command
FAS	Frame Alignment Signal
FEBE	Far End Block Error
FERF	Far End Receive Failure
FIFO	First In First Out
FIT	Failure In Time
FO	Frame Offset information
FOP	Failure Of Protocol
FS	Frame Start signal
HDB3	High Density Bipolar of order 3
HDLC	High-level Data Link Control procedure
HO	Higher Order
HOVC	Higher Order Virtual Container
HP	Higher order Path

ID	Identifier
IF	In Frame state
INC	INCrement
IOS	Intra-Office Section
IS	Intermediate System
ISDN	Integrated Services Digital Network
ISO	International Standardization Organization
ITU-T	International Telecommunications Union - Telecommunications Sector
LAN	Local Area Network
LBC	Laser Bias Current
LC	Link Connection
LLC	Logical Link Control
LMC	Laser Modulation Current
LO	Lower Order
LOA	Loss Of Alignment; generic for LOF, LOM, LOP
LOF	Loss Of Frame
LOM	Loss Of Multiframe
LOP	Loss Of Pointer
LOS	Loss Of Signal
LOT	Loss of Octet Timing
LOVC	Lower Order Virtual Container
LPx	Lower order Path for VC-x (x = 11, 12, 2, 3)
LT	Line Termination
M&CF	Management & Communication Function
MC	Matrix Connection
MCF	Message Communications Function
MDT	Mean Down Time
mei	maintenance event information
MI	Management Information
MO	Managed Object
MON	MONitored
MP	Management Point
MS	Multiplex Section
MS1	STM-1 Multiplex Section
MS16	STM-16 Multiplex Section
MS4	STM-4 Multiplex Section
MSB	Most Significant Bit
MSOH	Multiplex Section OverHead
MSP	Multiplex Section Protection
MSPG	Multiplex Section Protection Group
MTBF	Mean Time Between Failures
MTTR	Mean Time To Repair
N_B	Near-end Block
N_BBE	Near-end Background Block Error
N_DS	Near-end Defect Second
N_EBC	Near-end Errored Block Count
N_ES	Near-end Errored Second
N_SES	Near-end Severely Errored Second
N_SESTHR	Near-end Severely Errored Second THReshold
N_UAT_cmd	Near-end UnAvailable Time command
NC	Network Connection
NCM	No CRC-4 Multiframe alignment signal
NDF	New Data Flag
NE	Network Element
NMON	Not MONitored
NNI	Network Node Interface
NPDU	Network Protocol Data Unit
NRZ	Non-Return to Zero
NRZI	Non-Return to Zero Inverted
NSAP	Network Service Access Point

NU	National Use (bits, bytes)
NUx	National Use, bit rate order x
OAM	Operation, Administration and Management
OFS	Out of Frame Second
OOF	Out Of Frame state
OS	Optical Section
OSC	Oscillator
OSI(x)	Open Systems Interconnection, Layer x
OW	Order Wire
P	Protection
P_A	Protection Adaptation
P_C	Protection Connection
P_TT	Protection Trail Termination
P0_31c	1 984 kbit/s layer
P0s	synchronous 64 kbit/s layer
P11x	1 544 kbit/s layer (transparent)
P12s	2 048 kbit/s PDH path layer with synchronous 125 μ s frame structure according to ETS 300 167 [5]
P12x	2 048 kbit/s layer (transparent)
P22e	8 448 kbit/s PDH path layer with 4 plesiochronous 2 048 kbit/s
P22x	8 448 kbit/s layer (transparent)
P31e	34 368 kbit/s PDH path layer with 4 plesiochronous 8 448 kbit/s
P31s	34 368 kbit/s PDH path layer with synchronous 125 μ s frame structure according to ETS 300 337 [7]
P31x	34 368 kbit/s layer (transparent)
P32x	44 736 kbit/s layer (transparent)
P4e	139 264 kbit/s PDH path layer with 4 plesiochronous 34 368 kbit/s
P4s	139 264 kbit/s PDH path layer with synchronous 125 μ s frame structure according to ETS 300 337 [7]
P4x	139 264 kbit/s layer (transparent)
PDC	Photo Diode Current
PDH	Plesiochronous Digital Hierarchy
PJE	Pointer Justification Event
PLM	PayLoad Mismatch
PM	Performance Monitoring
Pn	Plesiochronous signal, Level n
POH	Path OverHead
PRC	Primary Reference Clock
PS	Protection Switching
PSC	Protection Switch Count
PSV	Power Supply Voltage
PTR	PoinTeR
PU	PDH Unit
QOS	Quality Of Service
RDI	Remote Defect Indicator
REI	Remote Error Indicator
RI	Remote Information
RLT	Regenerated Line Termination
RP	Remote Point
RS	Regenerator Section
RS1	STM-1 Regenerator Section
RS16	STM-16 Regenerator Section
RS4	STM-4 Regenerator Section
RSOH	Regenerator Section OverHead
RTG	Regenerator Timing Generator
RTR	Reset Threshold Report
RxSL	Received Signal Label
RxTI	Received Trace identifier
S11	VC-11 path layer
S12	VC-12 path layer

S2	VC-2 path layer
S3	VC-3 path layer
S4	VC-4 path layer
SASE	Stand-Alone Synchronization Equipment
SD	Synchronization Distribution layer, Signal Degrade
SD-2	2 048 kbit/s based timing source reference
SDA	Synchronization Distribution Adaptation
SD-C	2 048 kHz based timing source reference
SDH	Synchronous Digital Hierarchy
SD-N	STM-N based timing source reference
SDT	Synchronization Distribution Termination
SEC	SDH Equipment Clock
SES	Severely Errored Second
SESR	Severely Errored Seconds Ratio
SF	Signal Fail
SHR	Self Healing Ring
Sk	Sink
SLM	Signal Label Mismatch
SMF	Sub-Multi Frame
SMUX	Synchronous MULTipleXer
SNC	Sub-Network Connection
SNC/I	Inherently monitored Sub-Network Connection protection
SNC/N	Non-intrusively monitored Sub-Network Connection protection
So	Source
SOH	Section OverHead
SPRING	Shared Protection RING
SSD	Server Signal Degrade
SSF	Server Signal Fail
SSM	Synchronization Status Message
SSU	Synchronization Supply Unit
STM	Synchronous Transport Module
STM-N	Synchronous Transport Module, level N
T12	2 048 kHz signal
TCA	Threshold Crossing Alert
TCF	Timing Connection Function
TCN	Threshold Crossing Notification
TCP	Termination Connection Point
TD	Transmit Degrade
TF	Transmit Fail
TFAS	trail Trace identifier Frame Alignment Signal
TG	Timing Generator
TI	Timing Information
TIM	Trace Identifier Mismatch
TM	Transmission_Medium
TMN	Telecommunications Management Network
TP	Timing Point
TPmode	Termination Point mode
TPS	Transmission Protection Switch
TR	Threshold Report
TS	Time Slot
TSD	Trail Signal Degrade
TSF	Trail Signal Fail
TSL	Trail Signal Label
TT	Trail Termination function
TTI	Trail Trace Identifier
TTP	Trail Termination Point
TTs	Trail Termination supervisory function
TU	Tributary Unit
TUG	Tributary Unit Group
TUG-m	Tributary Unit Group, level m

TU-m	Tributary Unit, level m
TxSL	Transmitted Signal Label
TxTI	Transmitted Trace Identifier
UAS	UnAvailable Second
UAT	UnAvailable Time
UAT_cmd	UnAvailable Time command
UF	Unit Failure
UI	Unit Interval
UNEQ	UnEquipped
UNI	User to Network Interface
URLT	UnRegenerated Line Termination
USR	USeR channels
UVC	Unequipped VC
VC	Virtual Container
VC-n	Virtual Container, level n
VMR	Violation Monitoring and Removal
VP	Virtual Path
W	Working

3.3 Symbols and diagrammatic conventions

The symbols and diagrammatic conventions are described in EN 300 417-1-1 [8].

3.4 Introduction

The atomic functions defining the physical interface section layers are described below. They describe the physical and logical characteristics of the optical and electrical interfaces used in SDH equipments also with their adaptation functionality of PDH multiplex equipments described in the CCITT Recommendations G.751 [12] and G.742 [11] for signal hierarchies P4, P31 and P22, and adaptation functionality for SDH over PDH specified by ETS 300 337 [7] for signal hierarchies P4s and P31s and ETS 300 167 [5] for P12s layer signals.

The physical interface layers are defined for each of the synchronous and plesiochronous rates as defined in ETS 300 147 [3] and ETS 300 166 [4]. References to the signal structure are mentioned in the appropriate text subclauses.

4 STM-1 Optical Section Layer Functions

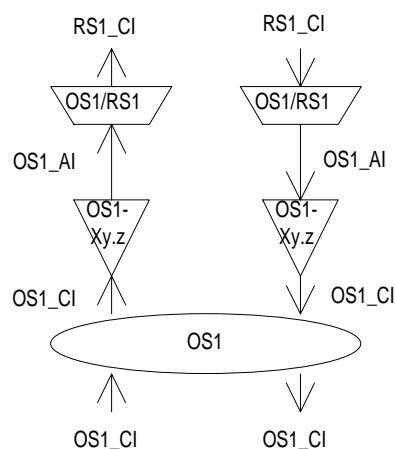

NOTE: Xy.z will be one value out of the set: {I1, S1.1, S1.2, L1.1, L1.2, L1.3}.

Figure 1: STM-1 Optical Section atomic functions

STM-1 Optical Section Layer CP

Characteristic Information OS1_CI of the optical layer CP (see figure 2) is a digital, optical signal of defined power, bit rate, pulse width and wavelength. A range of such characteristic signals for different optical power budgets is defined in ETS 300 232 [6].

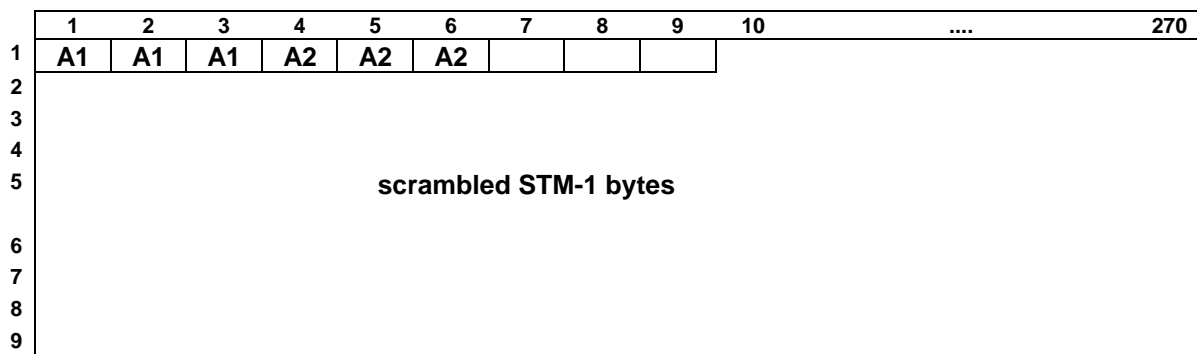

Figure 2: OS1 characteristic information OS1_CI (optical) and adapted information OS1_AI (electrical)

STM-1 Optical Section Layer AP

The information passing across the OS1 AP takes the form of a scrambled, digital bitstream (including a block frame character at 125 μs intervals) with co-directional bit timing (see figure 2). Frame characters and the synchronous, scrambling polynomial are defined in ETS 300 147 [3].

4.1 Optical Section Connection functions

For further study.

4.2 Optical Section Trail Termination functions

4.2.1 Optical Section Trail Termination Source OS1-Xy.z_TT_So

NOTE 1: Xy.z will be one value out of the set: {I1, S1.1, S1.2, L1.1, L1.2, L1.3}.

Symbol:

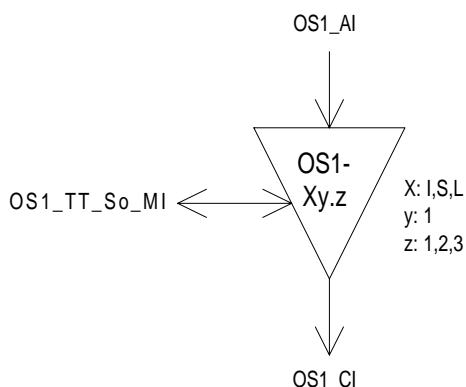

Figure 3: OS1-Xy.z_TT_So symbol

Interfaces:**Table 1: OS1-Xy.z_TT_So input and output signals**

Input(s)	Output(s)
OS1_AI_D	OS1_CI_D OS1_TT_So_MI_cTD OS1_TT_So_MI_cTF

Processes:

This function forms the optical STM-1 signal for transmission over the optical cable as defined in ETS 300 232 [6].

Optical characteristics: The function shall generate an optical STM-1 signal that meets the Xy.z characteristics defined in ETS 300 232 [6].

Defects:

dTD, dTF:

NOTE 2: Degraded signal implies that the output although still operational has fallen below some threshold of acceptability which requires maintenance intervention. The definition of the acceptability will in general be specific to a particular design or maintenance philosophy and is not defined in the present document. The defects are equipment specific.

Consequent Actions: None.

Defect Correlations:

cTF ← dTF;

cTD ← dTD and (not dTF).

Performance Monitoring: None.

4.2.2 Optical Section Trail Termination Sink OS1-Xy.z_TT_Sk

NOTE 1: Xy.z will be one value out of the set: {I1, S1.1, S1.2, L1.1, L1.2, L1.3}.

Symbol:

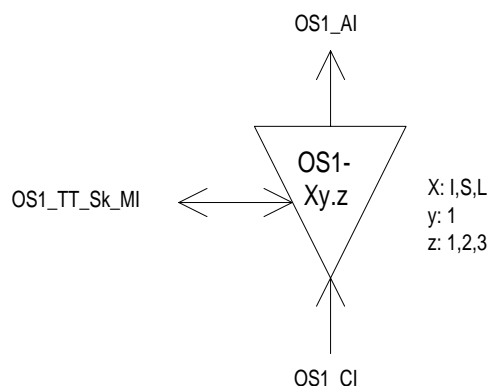

Figure 4: OS1-Xy.z_TT_Sk symbol

Interfaces:

Table 2: OS1-Xy.z_TT_Sk input and output signals

Input(s)	Output(s)
OS1_CI_D	OS1_AI_D
	OS1_AI_TSF
OS1_TT_Sk_MI_PortMode	OS1_TT_Sk_MI_cLOS

Processes:

This function recovers the optical STM-1 signal transmitted over the optical cables. The physical characteristics of the interface signal are defined in ETS 300 232 [6].

The function shall convert the received STM-1 signal, normally complying to the Xy.z characteristics defined in ETS 300 232 [6], into the internal OS1_AI signal.

Port Mode: The function shall have a port mode as specified by subclause 8.5 of EN 300 417-1-1 [8].

NOTE 2: The AUTO state of the port mode process is optional.

Defects:

The function shall detect Loss Of Signal defect (dLOS) according the optical STM-1 dLOS specification in subclause 8.2.1.6 of EN 300 417-1-1 [8].

Consequent Actions:

aTSF ← dLOS.

Defect Correlations:

cLOS ← MON and dLOS.

Performance Monitoring: None.

4.3 Optical Section Adaptation functions

4.3.1 Optical Section to Regenerator Section Adaptation Source OS1/RS1_A_So

Symbol:

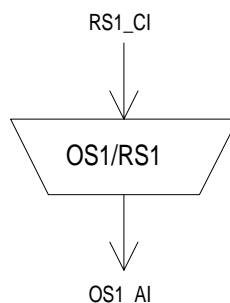

Figure 5: OS1/RS1_A_So symbol

Interfaces:

Table 3: OS1/RS1_A_So input and output signals

Input(s)	Output(s)
RS1_CI_D RS1_CI_CK	OS1_AI_D

Processes: None.

The function shall not add any jitter.

NOTE: Jitter at the NNI is the combination of the jitter generated and transferred via the client layers.

Defects: None.

Consequent Actions: None.

Defect Correlations: None.

Performance Monitoring: None.

4.3.2 Optical Section to Regenerator Section Adaptation Sink OS1/RS1_A_Sk

Symbol:

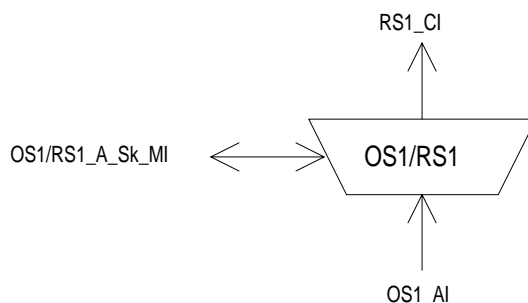

Figure 6: OS1/RS1_A_Sk symbol

Interfaces:

Table 4: OS1/RS1_A_Sk input and output signals

Input(s)	Output(s)
OS1_AI_D	RS1_CI_D
OS1_AI_TSF	RS1_CI_CK
	RS1_CI_FS
OS1/RS1_A_Sk_MI_1second	RS1_CI_SSF
	OS1/RS1_A_Sk_MI_cLOF
	OS1/RS1_A_Sk_MI_pOFS

Processes:

This function regenerates the received signal, recovers bit timing (CK) and Frame Start reference (FS) from the received signal.

Regeneration: The function shall operate with a maximum BER as specified in EN 300 417-1-1 [8], subclause 11.3.2.1 when any combination of the following signal conditions exist at the input:

- any input optical power level within the range specified in ETS 300 232 [6];
- jitter modulation applied to the input signal as specified in EN 300 417-1-1 [8], subclause 11.3.2.1;
- the input signal bit rate has any value in the range 155 520 kbit/s \pm 20 ppm.

NOTE: The frequency and jitter / wander tolerance might be further constrained by the requirements of the client layers.

To ensure adequate immunity against the presence of Consecutive Identical Digits (CID) in the STM-1 signal, the function shall comply with the specification in ITU-T Recommendation G.958 [16], section 7.4.

The function shall process the signal such that in the absence of input jitter, the intrinsic jitter at the STM-1 output interface (in a regenerative repeater) shall not exceed:

- 0,5 UI peak-to-peak when measured through a bandpass filter with corner frequencies at 500 Hz and 1,3 MHz and low pass roll off of 60 dB / decade and high pass roll off of 20 dB / decade;
- 0,1 UI peak-to-peak when measured through a bandpass filter with corner frequencies at 65 kHz and 1,3 MHz and low pass roll off of 60 dB / decade and high pass roll off of 20 dB / decade.

The function shall process the signal such that the jitter transfer (measured between an STM-1 input and STM-1 output in a regenerative repeater) shall be as specified in ITU-T Recommendation G.958 [16], subclause 9.3.2, Type A.

Frame alignment: The frame alignment shall be found by searching for the A1, A2 bytes contained in the STM-1 signal. The framing pattern searched for may be a subset of the A1 and A2 bytes contained on the STM-1 signal. The frame signal shall be continuously checked with the presumed frame start position for the alignment. If in the In-Frame state (IF), the maximum Out-Of-Frame (OOF) detection time shall be 625 μ s for a random unframed signal. The algorithm used to check the alignment shall be such that, under normal conditions, a 10^{-3} (Poisson type) error ratio will not cause a false OOF more than once per 6 minutes. If in the OOF state, the maximum frame alignment time shall be 250 μ s for an error-free signal with no emulated framing patterns. The algorithm used to recover from the OOF state shall be such, that the probability for false frame recovery with a random unframed signal shall be no more than 10^{-5} per 250 μ s time interval.

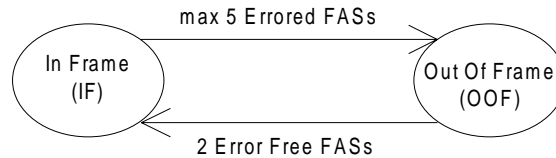
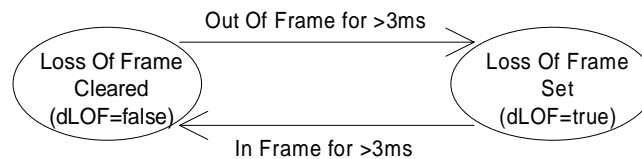

Figure 7: Frame alignment process

The frame start signal (RS1_CI_FS) shall be maintained during the OOF state and only updated upon successful transition from OOF to the IF state.

Defects:

If the OOF anomaly persists for 3 ms, a STM-1 Loss Of Frame defect (dLOF) shall be detected. To provide for the case of intermittent OOFs, the integrating timer shall not be reset to zero until an IF condition persists continuously for 3 ms. The dLOF defect shall be cleared when the IF state persists continuously for 3 ms.



NOTE: Out-Of-Frame integrating timer is not reset to zero until an In-Frame condition persists continuously for 3 ms.

Figure 8: Loss of frame process

Consequent Actions:

aAIS ← dLOF or AI_TSF;

aSSF ← dLOF or AI_TSF.

On declaration of an aAIS the function shall output an all-ONEs (AIS) signal - complying to the frequency limits for this interface - within 250 μ s; on clearing of aAIS the function shall output normal data within 250 μ s.

Defect Correlations:

cLOF ← dLOF and (not AI_TSF).

Performance Monitoring:

Any second with at least one OOF event shall be reported as an pOFS (Out of Frame Second).

5 STM-4 Optical Section Layer Functions

NOTE: Xy.z will be one value out of the set: {I4, S4.1, S4.2, L4.1, L4.2, L4.3}.

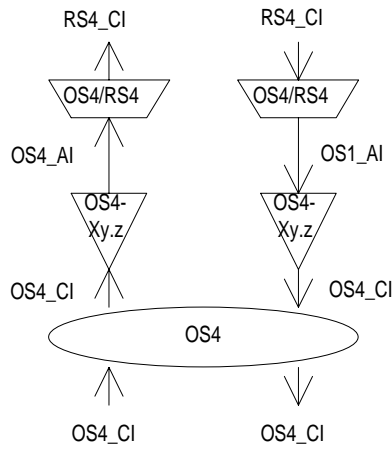

Figure 9: STM-4 Optical Section atomic functions

STM-4 Optical Section Layer CP

Characteristic Information OS4_CI of the optical layer CP (see figure 10) is a digital, optical signal of defined power, bit rate, pulse width and wavelength. A range of such characteristic signals for different optical power budgets is defined in ETS 300 232 [6].

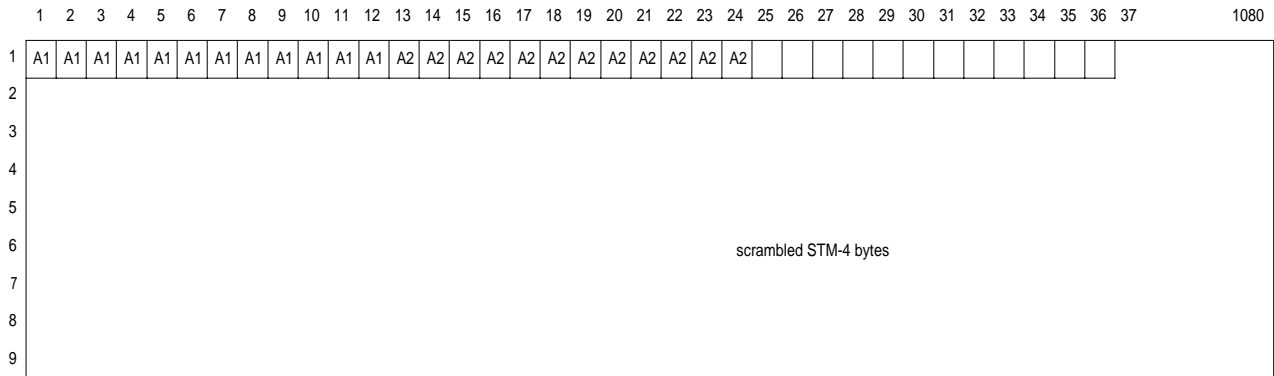

Figure 10: OS4 characteristic information OS4_CI (optical) and adapted information OS4_AI (electrical)

STM-4 Optical Section Layer AP

The information passing across the OS4 AP takes the form of a scrambled, digital bitstream (including a block frame character at 125 μs intervals) with co-directional bit timing (see figure 10). Frame characters and the synchronous, scrambling polynomial are defined in ETS 300 147 [3].

5.1 Optical Section Connection functions

For further study.

5.2 Optical Section Trail Termination functions

5.2.1 Optical Section Trail Termination Source OS4-Xy.z_TT_So

NOTE 1: Xy.z will be one value out of the set: {I4, S4.1, S4.2, L4.1, L4.2, L4.3}.

Symbol:

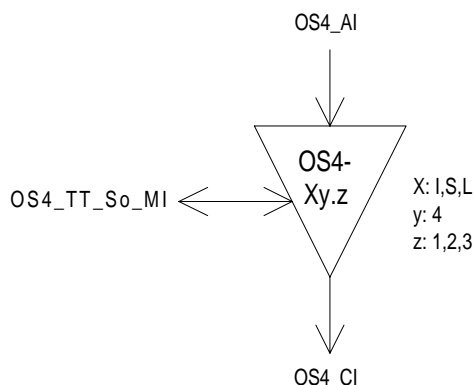

Figure 11: OS4-Xy.z_TT_So symbol

Interfaces:

Table 5: OS4-Xy.z_TT_So input and output signals

Input(s)	Output(s)
OS4_AI_D	OS4_CI_D OS4_TT_So_MI_cTD OS4_TT_So_MI_cTF

Processes:

This function forms the optical STM-4 signal for transmission over the optical cable as defined in ETS 300 232 [6].

Optical characteristics: The function shall generate an optical STM-4 signal that meets the Xy.z characteristics defined in ETS 300 232 [6].

Defects:

dTD, dTF:

NOTE 2: Degraded signal implies that the output although still operational has fallen below some threshold of acceptability which requires maintenance intervention. The definition of the acceptability will in general be specific to a particular design or maintenance philosophy and is not defined in the present document. The defects are equipment specific.

Consequent Actions: None.

Defect Correlations:

cTF ← dTF;

cTD ← dTD and (not dTF).

Performance Monitoring: None.

5.2.2 Optical Section Trail Termination Sink OS4-Xy.z_TT_Sk

NOTE 1: Xy.z will be one value out of the set: {I4, S4.1, S4.2, L4.1, L4.2, L4.3}.

Symbol:

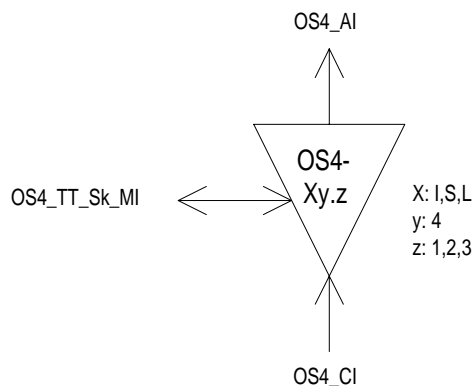

Figure 12: OS4-Xy.z_TT_Sk symbol

Interfaces:

Table 6: OS4-Xy.z_TT_Sk input and output signals

Input(s)	Output(s)
OS4_CI_D	OS4_AI_D
	OS4_AI_TSF
OS4_TT_Sk_MI_PortMode	OS4_TT_Sk_MI_cLOS

Processes:

This function recovers the optical STM-4 signal transmitted over the optical cables. The physical characteristics of the interface signal are defined in ETS 300 232 [6].

The function shall convert the received STM-4 signal, normally complying to the Xy.z characteristics defined in ETS 300 232 [6], into the internal OS4_AI signal.

Port Mode: The function shall have a port mode as specified by subclause 8.5 of EN 300 417-1-1 [8].

NOTE 2: The AUTO state of the port mode process is optional.

Defects:

The function shall detect Loss Of Signal defect (dLOS) according the optical STM-4 dLOS specification in subclause 8.2.1.6 of EN 300 417-1-1 [8].

Consequent Actions:

aTSF ← dLOS.

Defect Correlations:

cLOS ← MON and dLOS.

Performance Monitoring: None.

5.3 Optical Section Adaptation functions

5.3.1 Optical Section to Regenerator Section Adaptation Source OS4/RS4_A_So

Symbol:

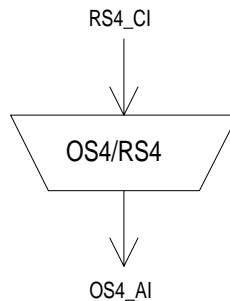

Figure 13: OS4/RS4_A_So symbol

Interfaces:

Table 7: OS4/RS4_A_So input and output signals

Input(s)	Output(s)
RS4_CI_D RS4_CI_CK	OS4_AI_D

Processes: None.

The function shall not add any jitter.

NOTE: Jitter at the NNI is the combination of the jitter generated and transferred via the client layers.

Defects: None.

Consequent Actions: None.

Defect Correlations: None.

Performance Monitoring: None.

5.3.2 Optical Section to Regenerator Section Adaptation Sink OS4/RS4_A_Sk

Symbol:

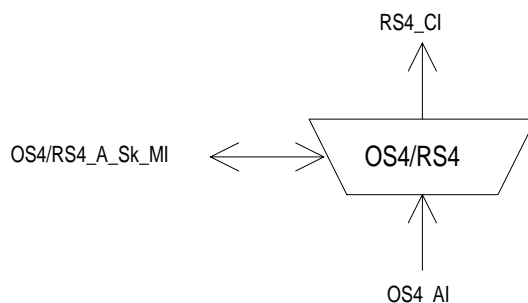

Figure 14: OS4/RS4_A_Sk symbol

Interfaces:

Table 8: OS4/RS4_A_Sk input and output signals

Input(s)	Output(s)
OS4_AI_D	RS4_CI_D
OS4_AI_TSF	RS4_CI_CK
	RS4_CI_FS
OS4/RS4_A_Sk_MI_1second	RS4_CI_SSF
	OS4/RS4_A_Sk_MI_cLOF
	OS4/RS4_A_Sk_MI_pOFS

Processes:

This function regenerates the received signal, recovers bit timing (CK) and Frame Start reference (FS) from the received signal.

Regeneration: The function shall operate with a maximum BER as specified in EN 300 417-1-1 [8], subclause 11.3.2.1 when any combination of the following signal conditions exist at the input:

- any input optical power level within the range specified in ETS 300 232 [6];
- jitter modulation applied to the input signals specified in EN 300 417-1-1 [8], subclause 11.3.2.1;
- the input signal bit rate has any value in the range 622 080 kbit/s \pm 20 ppm.

NOTE: The frequency and jitter / wander tolerance might be further constrained by the requirements of the client layers.

To ensure adequate immunity against the presence of Consecutive Identical Digits (CID) in the STM-4 signal, the function shall comply with the specification in ITU-T Recommendation G.958 [16], section 7.4.

The function shall process the signal such that in the absence of input jitter, the intrinsic jitter at the STM-4 output interface (in a regenerative repeater) shall not exceed:

- 0,5 UI peak-to-peak when measured through a bandpass filter with corner frequencies at 1 000 Hz and 5 MHz and low pass roll off of 60 dB / decade and high pass roll off of 20 dB / decade;
- 0,1 UI peak-to-peak when measured through a bandpass filter with corner frequencies at 250 kHz and 5 MHz and low pass roll off of 60 dB / decade and high pass roll off of 20 dB / decade.

The function shall process the signal such that the jitter transfer (measured between an STM-4 input and STM-4 output in a regenerative repeater) shall be as specified in ITU-T Recommendation G.958 [16], section 9.3.2, Type A.

Frame alignment: The frame alignment shall be found by searching for the A1, A2 bytes contained in the STM-4 signal. The framing pattern searched for may be a subset of the A1 and A2 bytes contained on the STM-4 signal. The frame signal shall be continuously checked with the presumed frame start position for the alignment. If in the In-Frame state (IF), the maximum Out-Of-Frame (OOF) detection time shall be 625 μ s for a random unframed signal. The algorithm used to check the alignment shall be such that, under normal conditions, a 10^{-3} (Poisson type) error ratio will not cause a false OOF more than once per 6 minutes. If in the OOF state, the maximum frame alignment time shall be 250 μ s for an error-free signal with no emulated framing patterns. The algorithm used to recover from the OOF state shall be such, that the probability for false frame recovery with a random unframed signal shall be no more than 10^{-5} per 250 μ s time interval.

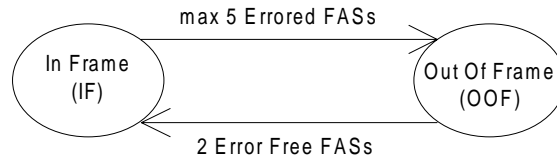
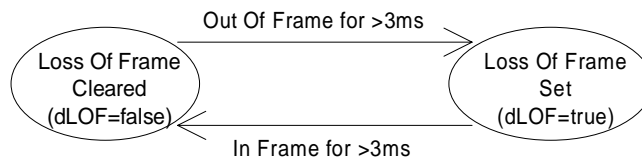

Figure 15: Frame alignment process

The frame start signal (RS4_CI_FS) shall be maintained during the OOF state and only updated upon successful transition from OOF to the IF state.

Defects:

If the OOF anomaly persists for 3 ms, a STM-4 Loss Of Frame defect (dLOF) shall be detected. To provide for the case of intermittent OOFs, the integrating timer shall not be reset to zero until an IF condition persists continuously for 3 ms. The dLOF defect shall be cleared when the IF state persists continuously for 3 ms.



NOTE: Out-Of-Frame integrating timer is not reset to zero until an In-Frame condition persists continuously for 3 ms.

Figure 16: Loss of frame process

Consequent Actions:

aAIS ← dLOF or AI_TSF;

aSSF ← dLOF or AI_TSF.

On declaration of an aAIS the function shall output an all-ONEs AIS signal - complying to the frequency limits for this interface - within 250 μ s; on clearing of aAIS the function shall output normal data within 250 μ s.

Defect Correlations:

cLOF ← dLOF and (not AI_TSF).

Performance Monitoring:

Any second with at least one OOF event shall be reported as an pOFS (Out of Frame Second).

6 STM-16 Optical Section Layer Functions

NOTE: $X_{y.z}$ will be one value out of the set: {I16, S16.1, S16.2, L16.1, L16.2, L16.3}.

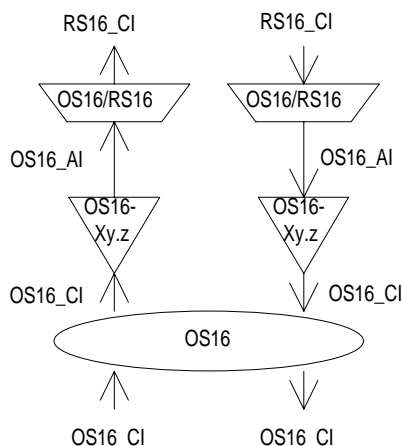

Figure 17: STM-16 Optical Section atomic functions

STM-16 Optical Section Layer CP

Characteristic Information OS16_CI of the optical layer CP (see figure 18) is a digital, optical signal of defined power, bit rate, pulse width and wavelength. A range of such characteristic signals for different optical power budgets is defined in ETS 300 232 [6].

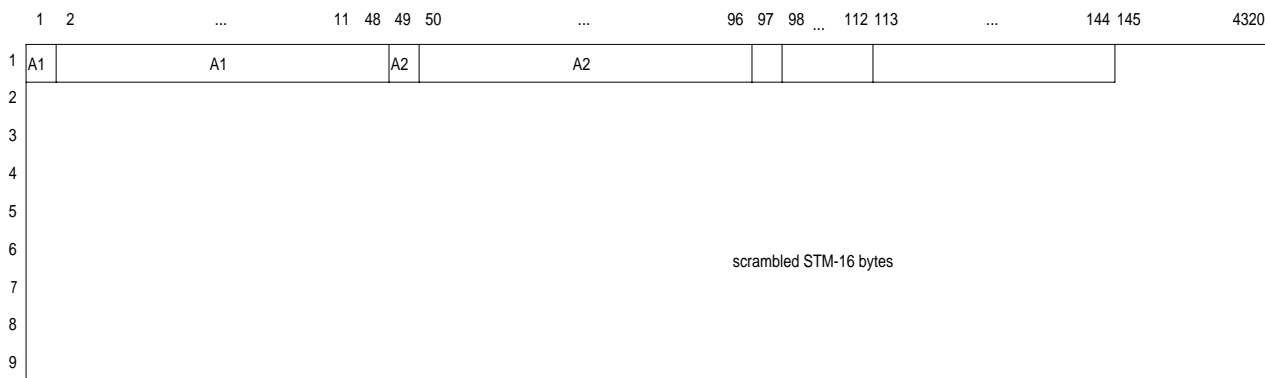

Figure 18: OS16 characteristic information OS16_CI (optical) and adapted information OS16_AI (electrical)

STM-16 Optical Section Layer AP

The information passing across the OS16 AP takes the form of a scrambled, digital bitstream (including a block frame character at 125 μ s intervals) with co-directional bit timing (see figure 18). Frame characters and the synchronous, scrambling polynomial are defined in ETS 300 147 [3].

6.1 Optical Section Connection functions

For further study.

6.2 Optical Section Trail Termination functions

6.2.1 Optical Section Trail Termination Source OS16-Xy.z_TT_So

NOTE 1: Xy.z will be one value out of the set: {I16, S16.1, S16.2, L16.1, L16.2, L16.3}.

Symbol:

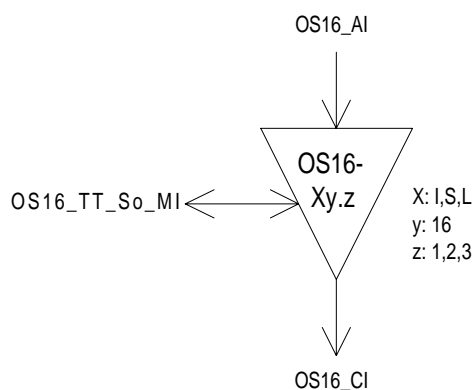

Figure 19: OS16-Xy.z_TT_So symbol

Interfaces:

Table 9: OS16_TT_So input and output signals

Input(s)	Output(s)
OS16_AI_D	OS16_CI_D OS16_TT_So_MI_cTD OS16_TT_So_MI_cTF

Processes:

This function forms the optical STM-16 signal for transmission over the optical cable as defined in ETS 300 232 [6].

Optical characteristics: The function shall generate an optical STM-16 signal that meets the Xy.z characteristics defined in ETS 300 232 [6].

Defects:

dTD, dTF:

NOTE 2: Degraded signal implies that the output although still operational has fallen below some threshold of acceptability which requires maintenance intervention. The definition of the acceptability will in general be specific to a particular design or maintenance philosophy and is not defined in the present document. The defects are equipment specific.

Consequent Actions: None.

Defect Correlations:

cTF ← dTF;

cTD ← dTD and (not dTF).

Performance Monitoring: None.

6.2.2 Optical Section Trail Termination Sink OS16-Xy.z_TT_Sk

NOTE 1: Xy.z will be one value out of the set: {I16, S16.1, S16.2, L16.1, L16.2, L16.3}.

Symbol:

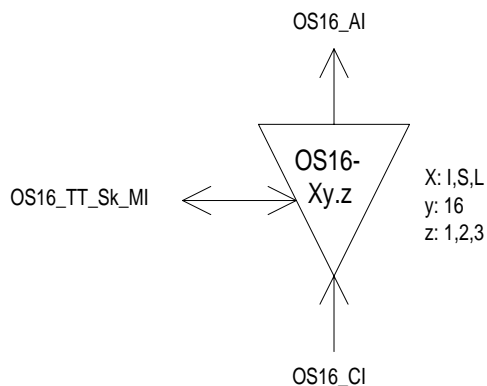

Figure 20: OS16-Xy.z_TT_Sk symbol

Interfaces:

Table 10: OS16_TT_Sk input and output signals

Input(s)	Output(s)
OS16_CI_D	OS16_AI_D
	OS16_AI_TSF
OS16_TT_Sk_MI_PortMode	OS16_TT_Sk_MI_cLOS

Processes:

This function recovers the optical STM-16 signal transmitted over the optical cables. The physical characteristics of the interface signal are defined in ETS 300 232 [6].

The function shall convert the received STM-16 signal, normally complying to the Xy.z characteristics defined in ETS 300 232 [6], into the internal OS16_AI signal.

Port Mode: The function shall have a port mode as specified by subclause 8.5 of EN 300 417-1-1 [8].

NOTE 2: The AUTO state of the port mode process is optional.

Defects:

The function shall detect Loss Of Signal defect (dLOS) according the optical STM-16 dLOS specification in subclause 8.2.1.6 of EN 300 417-1-1 [8].

Consequent Actions:

aTSF ← dLOS.

Defect Correlations:

cLOS ← MON and dLOS.

Performance Monitoring:

None.

6.3 Optical Section Adaptation functions

6.3.1 Optical Section to Regenerator Section Adaptation Source OS16/RS16_A_So

Symbol:

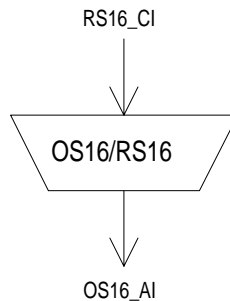

Figure 21: OS16/RS16_A_So symbol

Interfaces:

Table 11: OS16/RS16_A_So input and output signals

Input(s)	Output(s)
RS16_CI_D RS16_CI_CK	OS16_AI_D

Processes:

The function shall not add any jitter.

NOTE: Jitter at the NNI is the combination of the jitter generated and transferred via the client layers.

Defects: None.

Consequent Actions: None.

Defect Correlations: None.

Performance Monitoring: None.

6.3.2 Optical Section to Regenerator Section Adaptation Sink OS16/RS16_A_Sk

Symbol:

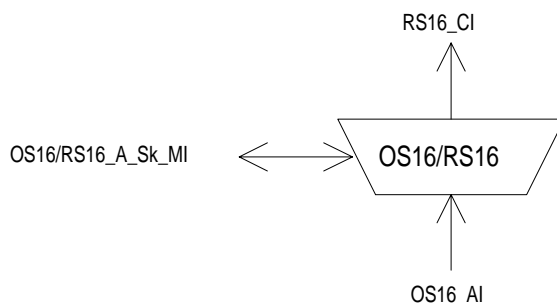

Figure 22: OS16/RS16_A_Sk symbol

Interfaces:

Table 12: OS16/RS16_A_Sk input and output signals

Input(s)	Output(s)
OS16_AI_D	RS16_CI_D
OS16_AI_TSF	RS16_CI_CK
	RS16_CI_FS
OS16/RS16_A_Sk_MI_1second	RS16_CI_SSF
	OS16/RS16_A_Sk_MI_cLOF
	OS16/RS16_A_Sk_MI_pOFS

Processes:

This function regenerates the received signal, recovers bit timing (CK) and Frame Start reference (FS) from the received signal.

Regeneration: The function shall operate with a maximum BER as specified in EN 300 417-1-1 [8], subclause 11.3.2.1 when any combination of the following signal conditions exist at the input:

- any input optical power level within the range specified in ETS 300 232 [6];
- jitter modulation applied to the input signal as specified in EN 300 417-1-1 [8], subclause 11.3.2.1;
- the input signal bit rate has any value in the range $2\,488\,320\text{ kbit/s} \pm 20\text{ ppm}$.

NOTE: The frequency and jitter / wander tolerance might be further constrained by the requirements of the client layers.

To ensure adequate immunity against the presence of Consecutive Identical Digits (CID) in the STM-16 signal, the function shall comply with the specification in ITU-T Recommendation G.958 [16], section 7.4.

The function shall process the signal such that in the absence of input jitter, the intrinsic jitter at the STM-16 output interface (in a regenerative repeater) shall not exceed:

- 0,5 UI peak-to-peak when measured through a bandpass filter with corner frequencies at 5 000 Hz and 20 MHz and low pass roll off of 60 dB / decade and high pass roll off of 20 dB / decade;
- 0,1 UI peak-to-peak when measured through a bandpass filter with corner frequencies at 1 MHz and 20 MHz and low pass roll off of 60 dB / decade and high pass roll off of 20 dB / decade.

The function shall process the signal such that the jitter transfer (measured between an STM-16 input and STM-16 output in a regenerative repeater) shall be as specified in ITU-T Recommendation G.958 [16], section 9.3.2, Type A.

Frame alignment: The frame alignment shall be found by searching for the A1, A2 bytes contained in the STM-16 signal. The framing pattern searched for may be a subset of the A1 and A2 bytes contained on the STM-16 signal. The frame signal shall be continuously checked with the presumed frame start position for the alignment. If in the In-Frame state (IF), the maximum Out-Of-Frame (OOF) detection time shall be 625 μ s for a random unframed signal. The algorithm used to check the alignment shall be such that, under normal conditions, a 10^{-3} (Poisson type) error ratio will not cause a false OOF more than once per 6 minutes. If in the OOF state, the maximum frame alignment time shall be 250 μ s for an error-free signal with no emulated framing patterns. The algorithm used to recover from the OOF state shall be such, that the probability for false frame recovery with a random unframed signal shall be no more than 10^{-5} per 250 μ s time interval.

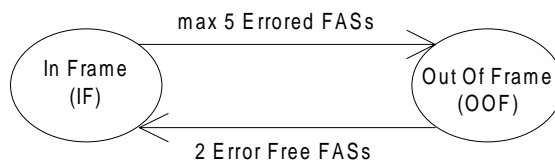
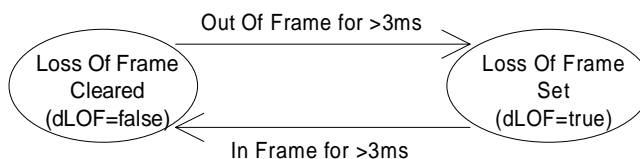

Figure 23: Frame alignment process

The frame start signal (RS16_CI_FS) shall be maintained during the OOF state and only updated upon successful transition from OOF to the IF state.

Defects:

If the OOF anomaly persists for 3 ms, a STM-16 Loss Of Frame defect (dLOF) shall be detected. To provide for the case of intermittent OOFs, the integrating timer shall not be reset to zero until an IF condition persists continuously for 3 ms. The dLOF defect shall be cleared when the IF state persists continuously for 3 ms.



NOTE: Out-Of-Frame integrating timer is not reset to zero until an In-Frame condition persists continuously for 3 ms.

Figure 24: Loss of frame process

Consequent Actions:

aAIS ← dLOF or AI_TSF;

aSSF ← dLOF or AI_TSF.

On declaration of an aAIS the function shall output an all-ONEs (AIS) signal - complying to the frequency limits for this interface - within 250 μ s; on clearing of aAIS the function shall output normal data within 250 μ s.

Defect Correlations:

cLOF ← dLOF and (not AI_TSF).

Performance Monitoring:

Any second with at least one OOF event shall be reported as an pOFS (Out of Frame Second).

7 STM-64 Optical Section Layer Functions

For further study.

8 STM-1 Electrical Section Layer Functions

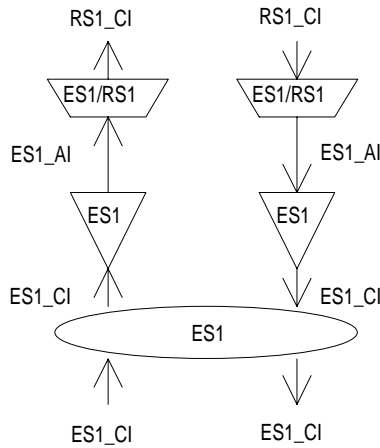

Figure 25: STM-1 Electrical Section atomic functions

STM-1 Electrical Section layer CP

The Characteristic Information ES1_CI of the intra-station electrical STM-1 layer CP (see figure 26) is a digital, CMI encoded, electrical signal of defined amplitude, bit rate and pulse shape as defined in ETS 300 166 [4].

NOTE: Characteristic information for a STM-1 UNI is for further study.

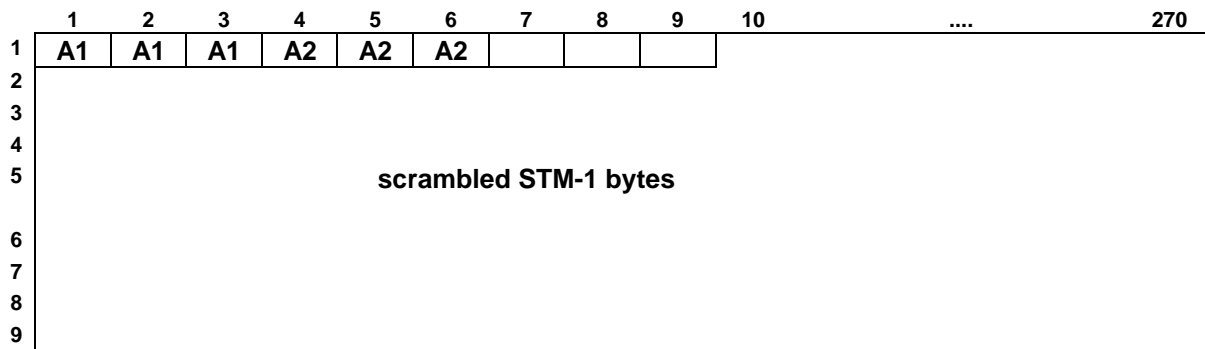

Figure 26: ES1 characteristic and adaptation information ES1_CI and ES1_AI

STM-1 Electrical Section layer AP

The information passing across the STM-1 ES AP takes the form of a scrambled, digital bitstream (including a block frame character at 125 μs intervals) with co-directional bit timing (see figure 26). Frame characters and the synchronous, scrambling polynomial is defined in ETS 300 147 [3].

8.1 STM-1 Electrical Section Connection function ES1_C

For further study.

8.2 STM-1 Electrical Section Trail Termination functions

8.2.1 STM-1 Electrical Section Trail Termination Source ES1_TT_So

Symbol:

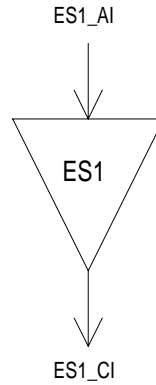

Figure 27: ES1_TT_So symbol

Interfaces:

Table 13: ES1_TT_So input and output signals

Input(s)	Output(s)
ES1_AI_D	ES1_CI_D

Processes:

This function generates the STM-1 electrical Intra-station Section Layer signal as specified by ETS 300 166 [4].

Pulse shape: The function shall meet the requirement specified by ETS 300 166 [4].

Peak to peak voltage: The function shall meet the requirement specified by ETS 300 166 [4].

Rise time: The function shall meet the requirement specified by ETS 300 166 [4].

Pair(s) in each direction: The function shall meet the requirement specified by ETS 300 166 [4].

Output return loss: The function shall meet the requirement specified by ETS 300 166 [4].

Defects: None.

Consequent Actions: None.

Defect Correlations: None.

Performance Monitoring: None.

8.2.2 STM-1 Electrical Section Trail Termination Sink ES1_TT_Sk

Symbol:

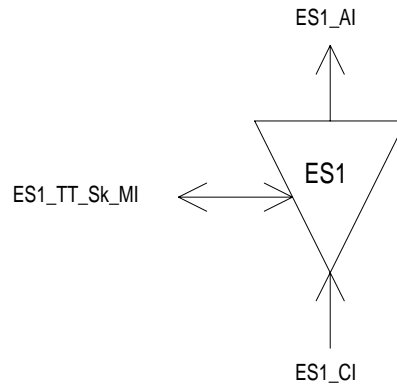

Figure 28: ES1-S1.1_TT_Sk symbol

Interfaces:

Table 14: ES1_TT_Sk input and output signals

Input(s)	Output(s)
ES1_CI_D	ES1_AI_D ES1_AI_TSF
ES1_TT_Sk_MI_PortMode	ES1_TT_Sk_MI_cLOS

Processes:

This function recovers the electrical STM-1 Intra-station Section Layer signal as defined in ETS 300 166 [4].

Input return loss: The function shall meet the requirement specified by ETS 300 166 [4].

Port Mode: The function shall have a port mode as specified by subclause 8.5 of EN 300 417-1-1 [8].

NOTE: The AUTO state of the port mode process is optional.

Defects:

The function shall detect Loss Of Signal defect (dLOS) according the electrical STM-1 dLOS specification in subclause 8.2.1.6 of EN 300 417-1-1 [8].

Consequent Actions:

aTSF ← dLOS.

Defect Correlations:

cLOS ← MON and dLOS.

Performance Monitoring: None.

8.3 STM-1 Electrical Section Adaptation functions

8.3.1 STM-1 Electrical Section to Regenerator Section Adaptation Source ES1/RS1_A_So

Symbol:

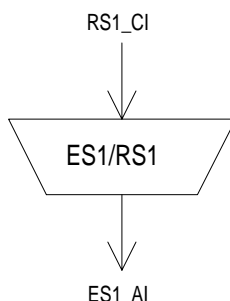

Figure 29: ES1/RS1_A_So symbol

Interfaces:

Table 15: ES1/RS1_A_So input and output signals

Input(s)	Output(s)
RS1_CI_D RS1_CI_CK	ES1_AI_D

Processes:

This function provides CMI encoding of the STM-1 signal.

CMI encoder: The function shall perform CMI encoding of the data specified by ETS 300 166 [4].

The CMI encoding process in the function shall process the signal such that in the absence of input jitter at the synchronization interface, the intrinsic jitter at the SMT-1 output interface as measured over a 60 seconds interval shall not exceed:

- 0,5 UI peak-peak when measured through a band-pass filter with corner frequencies at 500 Hz and 1,3 MHz and low pass roll off of 60 dB / decade and high pass roll off of 20 dB / decade;
- 0,075 UI peak-peak when measured through a band-pass filter with corner frequencies at 65 kHz and 1,3 MHz and low pass roll off of 60 dB / decade and high pass roll off of 20 dB / decade.

Consequent Actions: None.

Defect Correlations: None.

Performance Monitoring: None.

8.3.2 STM-1 Electrical Section to Regenerator Section Adaptation Sink ES1/RS1_A_Sk

Symbol:

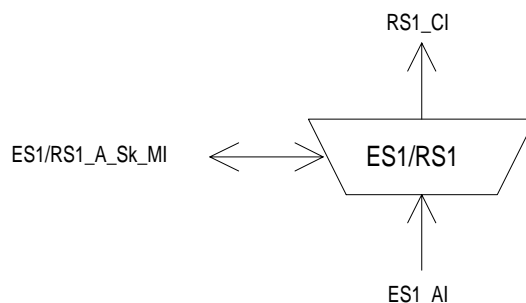

Figure 30: ES1/RS1_A_Sk symbol

Interfaces:

Table 16: ES1/RS1_A_Sk input and output signals

Input(s)	Output(s)
ES1_AI_D	RS1_CI_D
ES1_AI_TSF	RS1_CI_CK
	RS1_CI_FS
ES1/RS1_A_Sk_MI_1second	RS1_CI_SSF
	ES1/RS1_A_Sk_MI_cLOF
	ES1/RS1_A_Sk_MI_pOFS

Processes:

This function regenerates the received signal, recovers bit timing (CK) and Frame Start reference (FS) from the received signal, and decodes the incoming STM-1 signal.

Regeneration: The function shall operate without any errors when any combination of the following signal conditions exist at the input:

- an input electrical amplitude level with any value specified by ETS 300 166 [4];
- jitter modulation applied to the input signal with any value defined in ITU-T Recommendation G.825 [15];
- the input signal bit rate has any value in the range 155 520 kbit/s \pm 20 ppm.

NOTE: The frequency and jitter / wander tolerance might be further constrained by the requirements of the client layers.

CMI decoding: The function shall perform the CMI decoding process specified by ETS 300 166 [4].

Frame alignment: The frame alignment shall be found by searching for the A1, A2 bytes contained in the STM-1 signal. The framing pattern searched for may be a subset of the A1 and A2 bytes contained on the STM-1 signal. The frame signal shall be continuously checked with the presumed frame start position for the alignment. If in the In-Frame state (IF), the maximum Out-Of-Frame (OOF) detection time shall be 625 μ s for a random unframed signal. The algorithm used to check the alignment shall be such that, under normal conditions, a 10^{-3} (Poisson type) error ratio will not cause a false OOF more than once per 6 minutes. If in the OOF state, the maximum frame alignment time shall be 250 μ s for an error-free signal with no emulated framing patterns. The algorithm used to recover from the OOF state shall be such, that the probability for false frame recovery with a random unframed signal shall be no more than 10^{-5} per 250 μ s time interval.

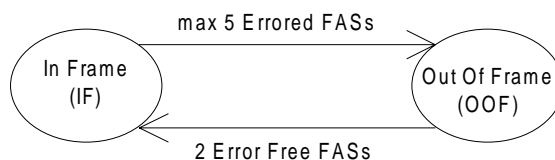
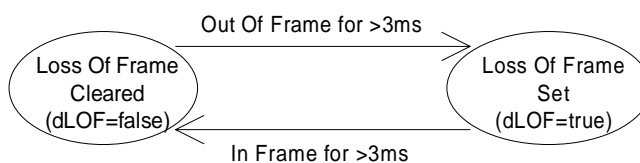

Figure 31: Frame alignment process

The frame start signal (RS1_CI_FS) shall be maintained during the OOF state and only updated upon successful transition from OOF to the IF state.

Defects:

If the OOF anomaly persists for 3 ms, a STM-1 Loss Of Frame defect (dLOF) shall be detected. To provide for the case of intermittent OOFs, the integrating timer shall not be reset to zero until an IF condition persists continuously for 3 ms. The dLOF defect shall be cleared when the IF state persists continuously for 3 ms.



NOTE: Out-Of-Frame integrating timer is not reset to zero until an In-Frame condition persists continuously for 3 ms.

Figure 32: Loss of frame process

Consequent Actions:

aAIS ← dLOF or AI_TSF.

aSSF ← dLOF or AI_TSF.

On declaration of aAIS the function shall output an all-ONEs (AIS) signal - complying to the frequency limits for this interface - within 250 μs; on clearing of aAIS the function shall output normal data within 250 μs.

Defect Correlations:

cLOF ← dLOF and (not AI_TSF).

Performance Monitoring:

Any second with at least one OOF event shall be reported as an pOFS (Out of Frame Second).

9 E4 Section Layer Functions

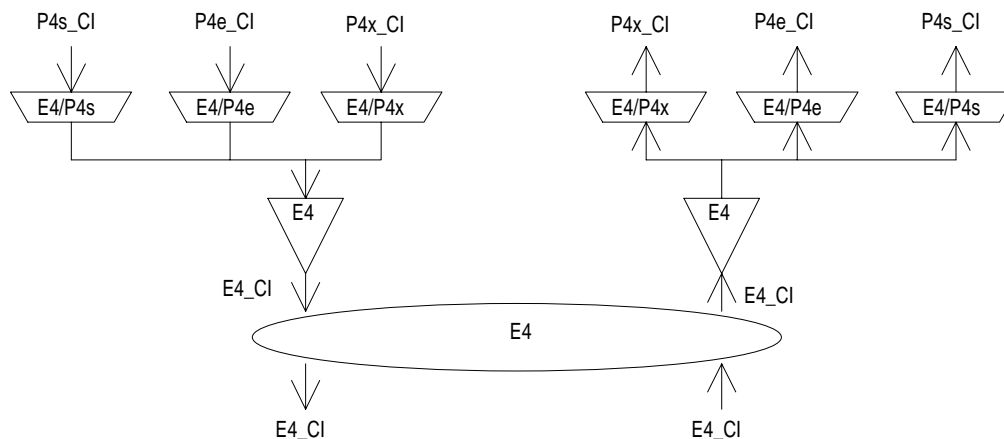

Figure 33: E4 Section atomic functions

E4 layer CP

The Characteristic Information E4_CI on the intra-station electrical layer CP is a digital, CMI encoded, electrical signal of defined amplitude, bit rate and pulse shape as defined in ETS 300 166 [4].

E4 layer AP

The information passing across the E4/P4x AP is a plesiochronous 139 264 kbit/s signal of non-specified content with co-directional bit timing.

The information passing across the E4/P4e AP is a 139 264 kbit/s signal with co-directional bit timing specified by CCITT Recommendation G.751 [12]. It contains four 34 368 kbit/s tributary signals (see figure 34).

Figure 33 shows that more than one adaptation function exists in this E4 layer that can be connected to one E4 access point. For the case of the adaptation source functions, only one of these adaptation source functions is allowed to be activated. For this activated source, access to the access point by other adaptation source functions shall be denied. In contradiction with the source direction, adaptation sink functions may be activated all together. This may cause faults (e.g. cLOF) to be detected and reported. To prevent this an adaptation sink function can be deactivated.

NOTE: If one adaptation function only is connected to the AP, it will be activated. If one or more other functions are connected to the same AP, one out of the set of functions will be active.

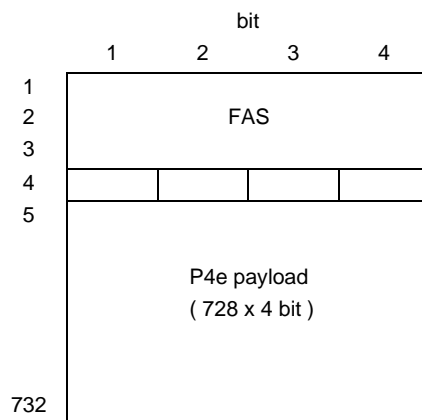

Figure 34: Decoded E4/P4e_AI_D signal

The information passing across the E4/P4s AP is a 139 264 kbit/s signal with co-directional bit timing specified by ETS 300 337 [7] (see figure 35).

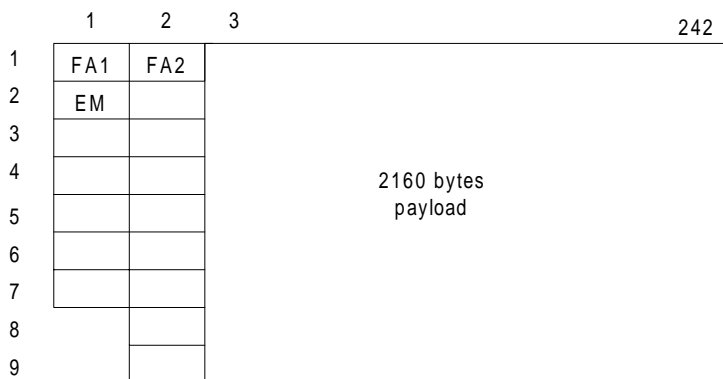

Figure 35: Decoded E4/P4s_AI_D signal

9.1 E4 Connection function E4_C

For further study.

9.2 E4 Trail Termination functions

9.2.1 E4 Trail Termination Source E4_TT_So

Symbol:

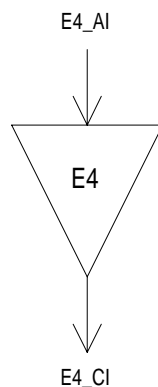

Figure 36: E4_TT_So symbol

Interfaces:

Table 17: E4_TT_So input and output signals

Input(s)	Output(s)
E4_AI_D	E4_CI_D

Processes:

This function generates the electrical Intra-station Section Layer signal E4 specified by ETS 300 166 [4].

Pulse shape: The function shall meet the requirement specified by ETS 300 166 [4].

Peak to Peak Voltage: The function shall meet the requirement specified by ETS 300 166 [4].

Rise time: The function shall meet the requirement specified by ETS 300 166 [4].

Pair(s) in each direction: The function shall meet the requirement specified by ETS 300 166 [4].

Output return loss: The function shall meet the requirement specified by ETS 300 166 [4].

Defects: None.

Consequent Actions: None.

Defect Correlations: None.

Performance Monitoring: None.

9.2.2 E4 Trail Termination Sink E4_TT_Sk

Symbol:

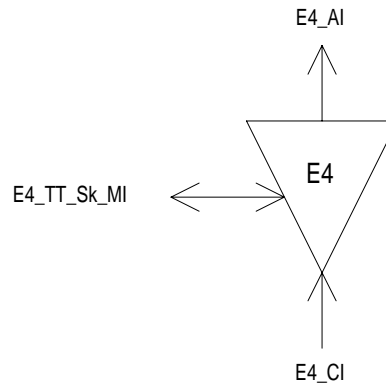

Figure 37: E4_TT_Sk symbol

Interfaces:

Table 18: E4_TT_Sk input and output signals

Input(s)	Output(s)
E4_CI_D	E4_AI_D E4_AI_TSF
E4_TT_Sk_MI_PortMode	E4_TT_Sk_MI_cLOS

Processes:

This function recovers the electrical Intra-station Section Layer signal E4 specified by ETS 300 166 [4].

Input return loss: The function shall meet the requirement specified by ETS 300 166 [4].

Port Mode: The function shall have a port mode as specified by subclause 8.5 of EN 300 417 1-1 [1].

NOTE: The AUTO state of the port mode process is optional.

Defects:

The function shall detect Loss Of Signal defect (dLOS) according the 139 264 kbit/s dLOS specification in subclause 8.2.1.6 of EN 300 417-1-1 [8].

Consequent Actions:

aTSF ← dLOS.

Defect Correlations:

cLOS ← MON and dLOS.

Performance Monitoring: None.

9.3 E4 Adaptation functions

9.3.1 E4 to P4x Adaptation Source E4/P4x_A_So

Symbol:

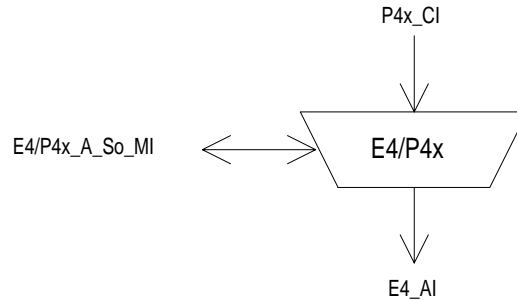

Figure 38: E4/P4x_A_So symbol

Interfaces:

Table 19: E4/P4x_A_So input and output signals

Input(s)	Output(s)
P4x_CI_D P4x_CI_CK E4/P4x_A_So_MI_Active	E4_AI_D

Processes:

This function provides the CMI encoding of the 139 264 kbit/s information stream as defined in ETS 300 166 [4].

CMI encoder: The function shall perform CMI encoding of the data specified by ETS 300 166 [4].

The function shall not add any jitter.

NOTE: Jitter at the NNI is the combination of the jitter generated and transferred via the client layers.

Activation: The function shall access the access point when it is activated (MI_Active is true). Otherwise, it shall not access the access point.

Defects: None.

Consequent Actions: None.

Defect Correlations: None.

Performance Monitoring: None.

9.3.2 E4 to P4x Adaptation Sink E4/P4x_A_Sk

Symbol:

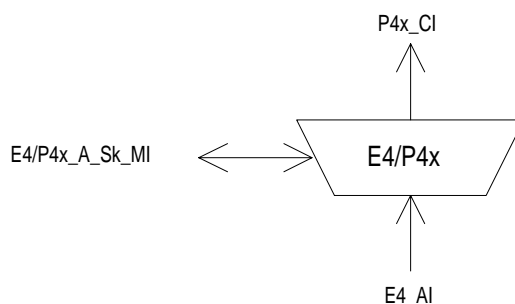

Figure 39: E4/P4x_A_Sk symbol

Interfaces:

Table 20: E4/P4x_A_Sk input and output signals

Input(s)	Output(s)
E4_AI_D	P4x_CI_D
E4_AI_TSF	P4x_CI_CK
E4/P4x_A_Sk_MI_Active	P4x_CI_SSF

Processes:

This function regenerates the received signal, recovers bit timing (CK) from the received signal, and decodes the incoming electrical 139 264 kbit/s E4 signal.

Regeneration: The function shall operate without any errors when any combination of the following signal conditions exist at the input:

- an input electrical amplitude level with any value in the range specified by ETS 300 166 [4];
- jitter modulation applied to the input signal with any value defined in ITU-T Recommendation G.823 [14];
- the input signal bit rate has any value in the range 139 264 kbit/s \pm 15 ppm.

NOTE: The frequency and jitter / wander tolerance might be further constrained by the requirements of the client layers.

CMI decoding: The function shall perform the CMI decoding process specified by ETS 300 166 [4].

Activation: The function shall perform the operation specified above when it is activated (MI_Active is true). Otherwise, it shall transmit the all-ONES signal at its output (CI_D) and not report its status via the management point.

Defects: None.

Consequent Actions:

aSSF \leftarrow AI_TSF.

aAIS \leftarrow AI_TSF.

On declaration of aAIS the function shall output an all-ONES (AIS) signal - complying to the frequency limits for this interface - within 250 μ s; on clearing of aAIS the function shall output normal data within 250 μ s.

Defect Correlations: None.

Performance Monitoring: None.

9.3.3 E4 to P4e Adaptation Source E4/P4e_A_So

Symbol:

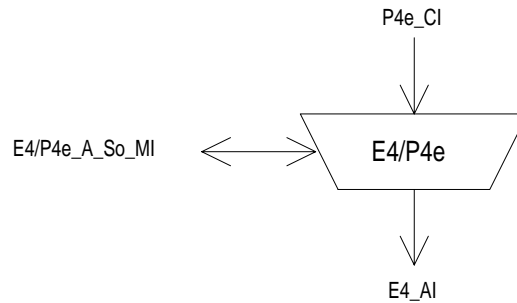

Figure 40: E4/P4e_A_So symbol

Interfaces:

Table 21: E4/P4e_So input and output signals

Input(s)	Output(s)
P4e_CI_D P4e_CI_CK E4/P4e_A_So_MI_Active	E4_AI_D

Processes:

This function performs CMI encoding of the 139 264 kbit/s signal.

CMI encoder: The function shall perform CMI encoding of the data as specified in ETS 300 166 [4].

The function shall not add any jitter.

NOTE: Jitter at the NNI is the combination of the jitter generated and transferred via the client layers.

Activation: The function shall access the access point when it is activated (MI_Active is true). Otherwise, it shall not access the access point.

Defects: None.

Consequent Actions: None.

Defect Correlations: None.

Performance Monitoring: None.

9.3.4 E4 to P4e Adaptation Sink E4/P4e_A_Sk

Symbol:

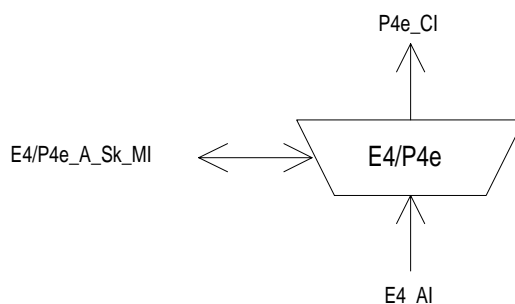

Figure 41: E4/P4e_A_Sk symbol

Interfaces:

Table 22: E4/P4e_Sk input and output signals

Input(s)	Output(s)
E4_AI_D	P4e_CI_D
	P4e_CI_CK
	P4e_CI_FS
E4_AI_TSF	P4e_CI_SSF
E4/P4e_A_Sk_MI_AIS_Reported	E4/P4e_A_Sk_MI_cLOF
E4/P4e_A_Sk_MI_Active	E4/P4e_A_Sk_MI_cAIS

Processes:

The function regenerates the received signal, recovers bit timing (CK) and Frame Start reference (FS) from the received signal, and decodes the incoming electrical 139 264 kbit/s E4 signal.

Regeneration: The function shall operate without any errors when any combination of the following signal conditions exist at the input:

- an input electrical amplitude level with any value in the range specified by ETS 300 166 [4];
- jitter modulation applied to the input signal with any value defined in ITU-T Recommendation G.823 [14];
- the input signal bit rate has any value in the range 139 264 kbit/s \pm 15 ppm.

NOTE: The frequency and jitter / wander tolerance might be further constrained by the requirements of the client layers.

CMI decoding: The function shall perform the CMI decoding process specified by ETS 300 166 [4].

Frame alignment: The function shall perform the frame alignment of the 139 264 kbit/s signal to recover the frame start signal FS. Loss of frame alignment shall be assumed to have taken place when four consecutive frame alignment signals have been incorrectly received in their predicted positions.

When frame alignment is assumed to be lost, the frame alignment device shall decide that such alignment has effectively been recovered when it detects the presence of three consecutive frame alignment signals.

The frame alignment device having detected the appearance of a single correct frame alignment signal, shall begin a new search for the frame alignment signal when it detects the absence of the frame alignment signal in one of the two following frames.

Activation: The function shall perform the operation specified above when it is activated (MI_Active is true). Otherwise, it shall transmit the all-ONEs signal at its output (CI_D) and not report its status via the management point.

Defects:

The function shall detect a loss of frame defect (dLOF) when four consecutive frame alignment signals have been incorrectly received in their predicted positions. When frame alignment is lost, the dLOF defect shall be cleared when three consecutive frame alignment signals are detected.

The function shall detect an AIS defect (dAIS) according the specification in subclause 8.2.1.7 of EN 300 417-1-1 [8], with $X = 5$, $Y = 2\ 928$, $Z = 6$.

Consequent Actions:

aAIS ← dAIS or dLOF or AI_TSF.

aSSF ← dAIS or dLOF or AI_TSF.

On declaration of aAIS the function shall output an all-ONEs (AIS) signal - complying to the frequency limits for this interface - within 250 μ s; on clearing of aAIS the function shall output normal data within 250 μ s.

Defect Correlations:

cAIS ← dAIS and (not AI_TSF) and AIS_Reported.

cLOF ← dLOF and (not dAIS) and (not AI_TSF).

Performance Monitoring: None.

9.3.5 E4 to P4s Adaptation Source E4/P4s_A_So

Symbol:

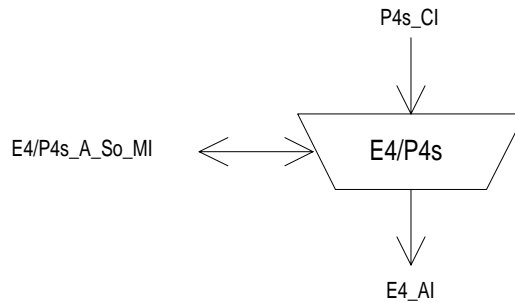

Figure 42: E4/P4s_A_So symbol

Interfaces:

Table 23: E4/P4s_So input and output signals

Input(s)	Output(s)
P4s_CI_D P4s_CI_CK E4/P4s_A_So_MI_Active	E4_AI_D

Processes:

This function provides CMI encoding of the 139 264 kbit/s P4s signal.

CMI encoder: The function shall perform CMI encoding of the data as specified in ETS 300 166 [4].

The function shall not add any jitter.

NOTE: Jitter at the NNI is the combination of the jitter generated and transferred via the client layers.

Activation: The function shall access the access point when it is activated (MI_Active is true). Otherwise, it shall not access the access point.

Defects: None.

Consequent Actions: None.

Defect Correlations: None.

Performance Monitoring: None.

9.3.6 E4 to P4s Adaptation Sink E4/P4s_A_Sk

Symbol:

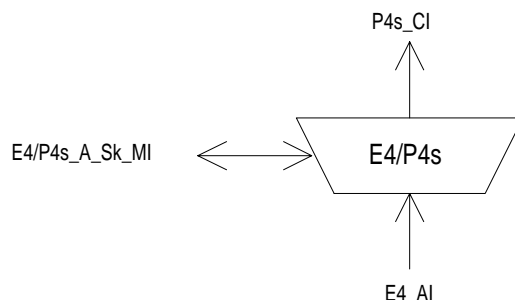

Figure 43: E4/P4s_A_Sk symbol

Interfaces:

Table 24: E4/P4s_Sk input and output signals

Input(s)	Output(s)
E4_AI_D	P4s_CI_D P4s_CI_CK P4s_CI_FS
E4_AI_TSF	P4s_CI_SSF
E4/P4s_A_Sk_MI_AIS_Reported	E4/P4s_A_Sk_MI_cLOF
E4/P4s_A_Sk_MI_Active	E4/P4s_A_Sk_MI_cAIS
E4/P4s_A_Sk_MI_1second	E4/P4s_A_Sk_MI_pOFS

Processes:

The function regenerates the received signal, recovers bit timing (CK), decodes the incoming electrical 139 264 kbit/s E4 signal, and recovers Frame Start reference (FS).

Regeneration: The function shall operate without any errors when any combination of the following signal conditions exist at the input:

- an input electrical amplitude level with any value in the range specified by ETS 300 166 [4];
- jitter modulation applied to the input signal with any value defined in ITU-T Recommendation G.823 [14];
- the input signal bit rate has any value in the range 139 264 kbit/s \pm 15 ppm.

NOTE 1: The frequency and jitter / wander tolerance might be further constrained by the requirements of the client layers.

CMI decoding: The function shall perform the CMI decoding process specified by ETS 300 166 [4].

Frame alignment: The function shall perform the frame alignment of the 139 264 kbit/s signal to recover the frame start signal FS. The frame alignment shall be found by searching for the A1, A2 bytes contained in the 140 Mbit/s signal. The frame signal shall be continuously checked with the presumed frame start position for the alignment.

Frame alignment is deemed to have been lost (entering Out Of Frame (OOF) state) when either:

- four consecutive FAS are detected in error (i.e. \geq 1 error in each FAS);
- 986 or more frames with one or more BIP8 violations are detected in a block of 1 000 frames.

Frame alignment is deemed to have been recovered (entering In Frame (IF) state) when three consecutive non-errored FAS are found.

In the IF state even bit parity (BIP-8) is computed for each bit n of every byte of the preceding frame and compared with bit n of the EM byte recovered from the current frame. A difference between the computed BIP-8 and the EM value is taken as evidence of one or more errors in the previous frame.

NOTE 2: This process is identical with the BIP-8 violation process of the P4s_TT_Sk function. The process may be used in common for both functions.

Should a research for frame alignment be initiated either due to:

- a fortuitous FAS position being found once and not being found a second time in its expected position;
- exceeding the threshold which indicates false alignment;

then the new search for frame alignment should start 1 bit displaced forward from the position of the last indication of frame alignment.

NOTE 3: The above is required in order to avoid repeated alignment on to a simulation of the framing location.

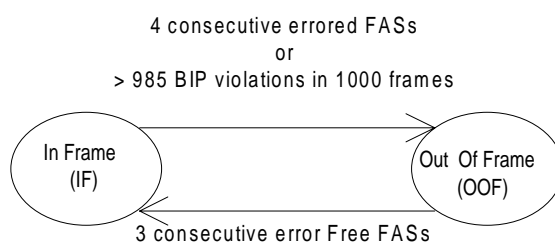

Figure 44: Frame alignment state diagram

Activation: The function shall perform the operation specified above when it is activated (MI_Active is true). Otherwise, it shall transmit the all-ONEs signal at its output (CI_D) and not report its status via the management point.

Defects:

If the frame alignment is deemed to be lost (OOF state), a 140 Mbit/s Loss Of Frame defect (dLOF) shall be detected. The dLOF defect shall be cleared when the frame alignment is deemed to have been recovered (IF state).

The dAIS defect shall be detected specified by EN 300 417-1-1 [8], subclause 8.2.1.7 for 140 Mbit/s, with $X = 7$, $Y = 17\ 408$, $Z = 8$.

Consequent Actions:

aAIS ← dAIS or dLOF or AI_TSF.

aSSF ← dAIS or dLOF or AI_TSF.

On declaration of aAIS the function shall output an all-ONEs (AIS) signal - complying to the frequency limits for this interface - within 250 μ s; on clearing of aAIS the function shall output normal data within 250 μ s.

Defect Correlations:

cAIS ← dAIS and (not AI_TSF) and AIS_Reported.

cLOF ← dLOF and (not dAIS) and (not AI_TSF).

Performance Monitoring: None.

10 E31 Section Layer Functions

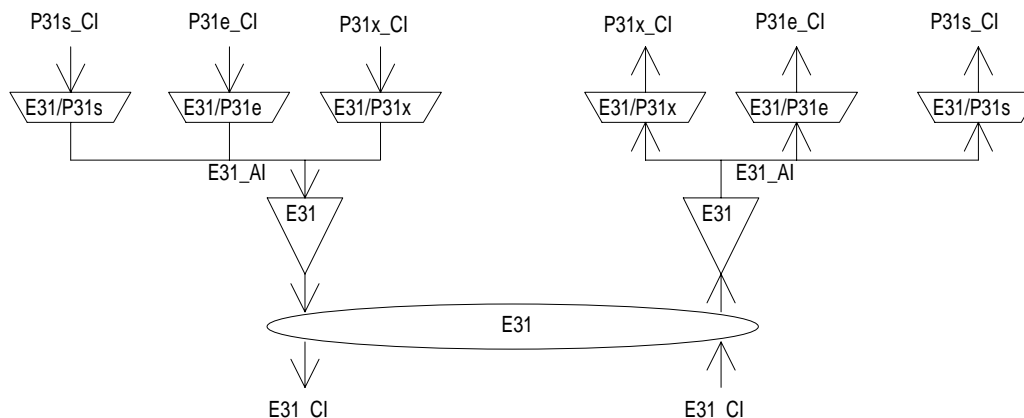

Figure 45: E31 Section atomic functions

E31 layer CP

The Characteristic Information E31_CI of the intra-station electrical layer CP is a digital, electrical signal of defined amplitude, bit rate and pulse shape specified by ETS 300 166 [4].

E31 layer AP

The information passing across the E31/P31x AP is a 34 368 kbit/s signal of non-specified content with co-directional bit timing.

The information passing across the E31/P31e AP is a 34 368 kbit/s signal with co-directional bit timing specified by CCITT Recommendation G.751 [12]. It contains four 8 448 kbit/s tributary signals (see figure 46).

Figure 45 shows that more than one adaptation function exists in this E31 layer that can be connected to one E31 access point. For the case of the adaptation source functions, only one of these adaptation source functions is allowed to be activated. For this activated source, access to the access point by other adaptation source functions shall be denied. In contradiction with the source direction, adaptation sink functions may be activated all together. This may cause faults (e.g. cLOF) to be detected and reported. To prevent this an adaptation sink function can be deactivated.

NOTE: If one adaptation function only is connected to the AP, it will be activated. If one or more other functions are connected to the same AP, one out of the set of functions will be active.

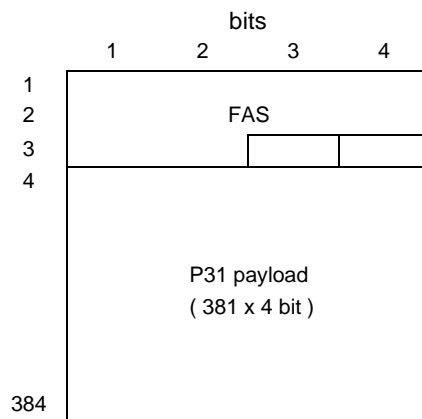

Figure 46: Decoded E31/P31e_AI_D signal

The information passing across the E31/P31s AP is a 34 368 kbit/s signal with co-directional bit timing specified by ETS 300 337 [7] (see figure 47).

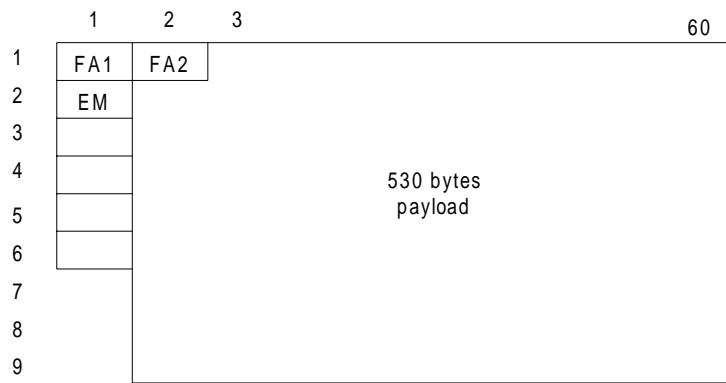

Figure 47: Decoded E31/P31s_AI_D signal

10.1 E31 Connection function E31_C

For further study.

10.2 E31 Trail Termination functions

10.2.1 E31 Trail Termination Source E31_TT_So

Symbol:

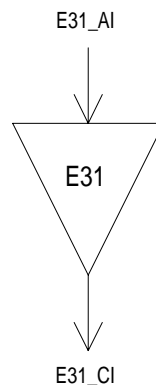

Figure 48: E31_TT_So symbol

Interfaces:

Table 25: E31_TT_So input and output signals

Input(s)	Output(s)
E31_AI_D	E31_CI_D

Processes:

This function generates the electrical Intra-station Section Layer signal E31 specified by ETS 300 166 [4].

Pulse shape: The function shall meet the requirement specified by ETS 300 166 [4].

Nominal Peak to Peak Voltage of a mark (pulse): The function shall meet the requirement specified by ETS 300 166 [5].

Peak voltage of a space (no pulse): The function shall meet the requirement specified by ETS 300 166 [4].

Nominal pulse width: The function shall meet the requirement specified by ETS 300 166 [4].

Ratio of the amplitudes of positive and negative pulses at the centre of the pulse interval: The function shall meet the requirement specified by ETS 300 166 [4].

Ratio of widths of positive and negative pulses at the nominal half amplitude: The function shall meet the requirement specified by ETS 300 166 [4].

Pair(s) in each direction: The function shall meet the requirement specified by ETS 300 166 [4].

Output return loss: The function shall meet the requirement specified by ETS 300 166 [4].

Defects: None.

Consequent Actions: None.

Defect Correlations: None.

Performance Monitoring: None.

10.2.2 E31 Trail Termination Sink E31_TT_Sk

Symbol:

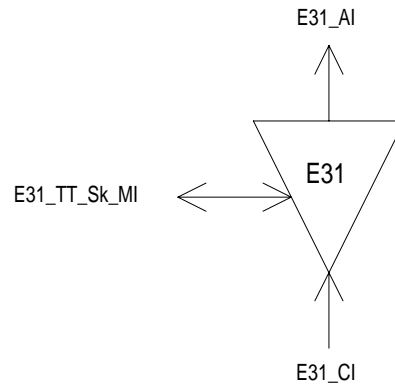

Figure 49: E31_TT_Sk symbol

Interfaces:

Table 26: E31_TT_Sk input and output signals

Input(s)	Output(s)
E31_CI_D	E31_AI_D E31_AI_TSF
E31_TT_Sk_MI_PortMode	E31_TT_Sk_MI_cLOS

Processes:

This function recovers the electrical Intra-station Section Layer signal E31 specified by ETS 300 166 [4].

Input return loss: The function shall meet the requirement specified by ETS 300 166 [4].

Port Mode: The function shall have a port mode as specified by subclause 8.5 of EN 300 417-1-1 [8].

NOTE: The AUTO state of the port mode process is optional.

Defects:

The function shall detect Loss Of Signal defect (dLOS) according the 34 368 kbit/s dLOS specification in subclause 8.2.1.6 of EN 300 417-1-1 [8].

Consequent Actions:

aTSF ← dLOS.

Defect Correlations:

cLOS ← MON and dLOS.

Performance Monitoring: None.

10.3 E31 Adaptation functions

10.3.1 E31 to P31x Adaptation Source E31/P31x_A_So

Symbol:

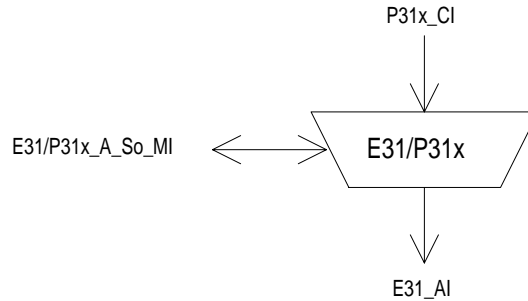

Figure 50: E31/P31x_A_So symbol

Interfaces:

Table 27: E31/P31x_A_So input and output signals

Input(s)	Output(s)
P31x_CI_D P31x_CI_CK E31/P31x_A_So_MI_Active	E31_AI_D

Processes:

This function provides the HDB3 encoding of the 34 368 kbit/s information stream specified by ETS 300 166 [4].

HDB3 encoder: The function shall perform HDB3 encoding of the data as specified in ETS 300 166 [4].

The function shall not add any jitter.

NOTE: Jitter at the NNI is the combination of the jitter generated and transferred via the client layers.

Activation: The function shall access the access point when it is activated (MI_Active is true). Otherwise, it shall not access the access point.

Defects: None.

Consequent Actions: None.

Defect Correlations: None.

Performance Monitoring: None.

10.3.2 E31 to P31x Adaptation Sink E31/P31x_A_Sk

Symbol:

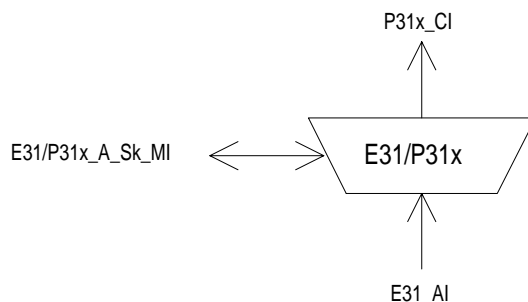

Figure 51: E31/P31x_A_Sk symbol

Interfaces:

Table 28: E31/P31x_A_Sk input and output signals

Input(s)	Output(s)
E31_AI_D	P31x_CI_D
E31_AI_TSF	P31x_CI_CK
E31/P31x_A_Sk_MI_Active	P31x_CI_SSF

Processes:

This function regenerates the received signal, recovers bit timing (CK) from the received signal, and decodes the incoming electrical 34 368 kbit/s E31 signal.

Regeneration: The function shall operate without any errors when any combination of the following signal conditions exist at the input:

- an input electrical amplitude level with any value in the range specified by ETS 300 166 [4];
- jitter modulation applied to the input signal with any value defined in ITU-T Recommendation G.823 [14];
- the input signal bit rate has any value in the range 34 368 kbit/s \pm 20 ppm;
- the input signal has an interfering signal specified by ETS 300 166 [4].

NOTE: The frequency and jitter / wander tolerance might be further constrained by the requirements of the client layers.

HDB3 decoding: The function shall perform the HDB3 decoding process specified by ETS 300 166 [4].

Activation: The function shall perform the operation specified above when it is activated (MI_Active is true). Otherwise, it shall transmit the all-ONES signal at its output (CI_D) and not report its status via the management point.

Defects: None.

Consequent Actions:

aSSF \leftarrow AI_TSF.

aAIS \leftarrow AI_TSF.

On declaration of aAIS the function shall output an all-ONES (AIS) signal - complying to the frequency limits for this interface - within 250 μ s; on clearing of aAIS the function shall output normal data within 250 μ s.

Defect Correlations: None.

Performance Monitoring: None.

10.3.3 E31 to P31e Adaptation Source E31/P31e_A_So

Symbol:

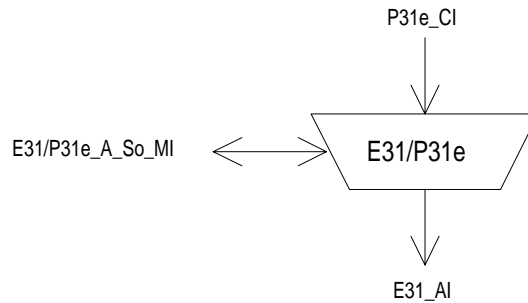

Figure 52: E31/P31e_A_So symbol

Interfaces:

Table 29: E31/P31e_A_So input and output signals

Input(s)	Output(s)
P31e_CI_D P31e_CI_CK E31/P31e_A_So_MI_Active	E31_AI_D

Processes:

This function performs HDB3 encoding of the 34 368 kbit/s signal.

HDB3 encoder: The function shall perform HDB3 encoding of the data as specified in ETS 300 166 [4].

The function shall not add any jitter.

NOTE: Jitter at the NNI is the combination of the jitter generated and transferred via the client layers.

Activation: The function shall access the access point when it is activated (MI_Active is true). Otherwise, it shall not access the access point.

Defects: None.

Consequent Actions: None.

Defect Correlations: None.

Performance Monitoring: None.

10.3.4 E31 to P31e Adaptation Sink E31/P31e_A_Sk

Symbol:

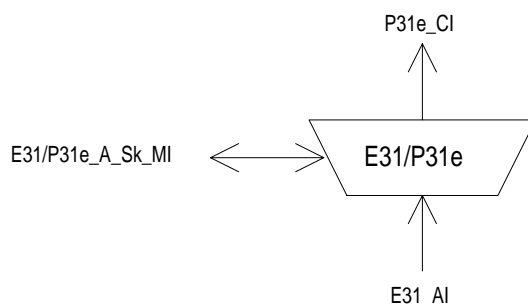

Figure 53: E31/P31e_A_Sk symbol

Interfaces:

Table 30: E31/P31e_A_Sk input and output signals

Input(s)	Output(s)
E31_AI_D	P31e_CI_D
	P31e_CI_CK
	P31e_CI_FS
E31_AI_TSF	P31e_CI_SSF
E31/P31e_A_Sk_MI_AIS_Reported	E31/P31e_A_Sk_MI_cLOF
E31/P31e_A_Sk_MI_Active	E31/P31e_A_Sk_MI_cAIS

Processes:

The function regenerates the received signal, recovers bit timing (CK) and Frame Start reference (FS) from the received signal, and decodes the incoming electrical 34 368 kbit/s E31 signal.

Regeneration: The function shall operate without any errors when any combination of the following signal conditions exist at the input:

- an input electrical amplitude level with any value in the range specified by ETS 300 166 [4];
- jitter modulation applied to the input signal with any value defined in ITU-T Recommendation G.823 [14];
- the input signal bit rate has any value in the range 34 368 kbit/s \pm 20 ppm;
- the input signal has an interfering signal specified by ETS 300 166 [4].

NOTE: The frequency and jitter / wander tolerance might be further constrained by the requirements of the client layers.

HDB3 decoding: The function shall perform the HDB3 decoding process specified by ETS 300 166 [4].

Frame alignment: The function shall perform the frame alignment of the 34 368 kbit/s signal to recover the frame start signal FS. Loss of frame alignment shall be assumed to have taken place when four consecutive frame alignment signals have been incorrectly received in their predicted positions.

When frame alignment is assumed to be lost, the frame alignment device shall decide that such alignment has effectively been recovered when it detects the presence of three consecutive frame alignment signals.

The frame alignment device having detected the appearance of a single correct frame alignment signal, shall begin a new search for the frame alignment signal when it detects the absence of the frame alignment signal in one of the two following frames.

Activation: The function shall perform the operation specified above when it is activated (MI_Active is true). Otherwise, it shall transmit the all-ONEs signal at its output (CI_D) and not report its status via the management point.

Defects:

The function shall detect a loss of frame defect (dLOF) when four consecutive frame alignment signals have been incorrectly received in their predicted positions. When frame alignment is lost, the dLOF defect shall be cleared when three consecutive frame alignment signals are detected.

The function shall detect an AIS defect (dAIS) according the specification in subclause 8.2.1.7 of EN 300 417-1-1 [8], with $X = 4$, $Y = 1\ 536$, $Z = 5$.

Consequent Actions:

aAIS ← dAIS or dLOF or AI_TSF.

aSSF ← dAIS or dLOF or AI_TSF.

On declaration of aAIS the function shall output an all-ONEs (AIS) signal - complying to the frequency limits for this interface - within 250 μ s; on clearing of aAIS the function shall output normal data within 250 μ s.

Defect Correlations:

cAIS ← dAIS and (not AI_TSF) and AIS_Reported.

cLOF ← dLOF and (not dAIS) and (not AI_TSF).

Performance Monitoring: None.

10.3.5 E31 to P31s Adaptation Source E31/P31s_A_So

Symbol:

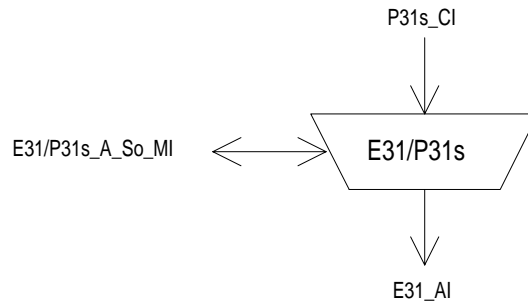

Figure 54: E31/P31s_A_So symbol

Interfaces:

Table 31: E31/P31s_A_So input and output signals

Input(s)	Output(s)
P31s_CI_D P31s_CI_CK E31/P31s_A_So_MI_Active	E31_AI_D

Processes:

This function provides HDB3 encoding of the 34 368 kbit/s P31s signal.

HDB3 encoder: The function shall perform HDB3 encoding of the data as specified in ETS 300 166 [4].

The function shall not add any jitter.

NOTE: Jitter at the NNI is the combination of the jitter generated and transferred via the client layers.

Activation: The function shall access the access point when it is activated (MI_Active is true). Otherwise, it shall not access the access point.

Defects: None.

Consequent Actions: None.

Defect Correlations: None.

Performance Monitoring: None.

10.3.6 E31 to P31s Adaptation Sink E31/P31s_A_Sk

Symbol:

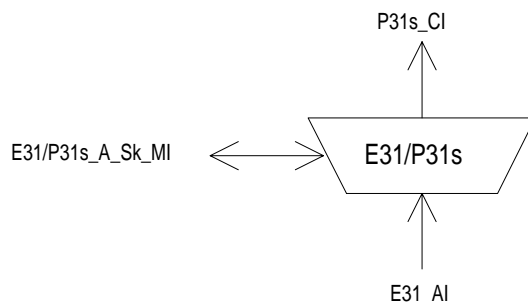

Figure 55: E31/P31s_A_Sk symbol

Interfaces:

Table 32: E31/P31s_A_Sk input and output signals

Input(s)	Output(s)
E31_AI_D	P31s_CI_D P31s_CI_CK P31s_CI_FS
E31_AI_TSF	P31s_CI_SSF
E31/P31s_A_Sk_MI_AIS_Reported	E31/P31s_A_Sk_MI_cLOF
E31/P31s_A_Sk_MI_Active	E31/P31s_A_Sk_MI_cAIS
E31/P31s_A_Sk_MI_1second	E31/P31s_A_Sk_MI_pOFS

Processes:

The function regenerates the received signal, recovers bit timing (CK), decodes the incoming electrical 34 368 kbit/s E31 signal, and recovers Frame Start reference (FS). It supplies the recovered timing signal to the synchronization distribution layer. It can be activated / deactivated when multiple adaptation function types are connected to the access point.

Regeneration: The function shall operate without any errors when any combination of the following signal conditions exist at the input:

- an input electrical amplitude level with any value in the range specified by ETS 300 166 [4];
- jitter modulation applied to the input signal with any value defined in ITU-T Recommendation G.823 [14];
- the input signal bit rate has any value in the range 34 368 kbit/s \pm 20 ppm;
- the input signal has an interfering signal specified by ETS 300 166 [4].

NOTE 1: The frequency and jitter / wander tolerance might be further constrained by the requirements of the client layers.

HDB3 decoding: The function shall perform the HDB3 decoding process specified by ETS 300 166 [4].

Frame alignment: The function shall perform the frame alignment of the 34 368 kbit/s signal to recover the frame start signal FS. The frame alignment shall be found by searching for the A1, A2 bytes contained in the 34 Mbit/s signal. The frame signal shall be continuously checked with the presumed frame start position for the alignment.

Frame alignment is deemed to have been lost (entering Out Of Frame (OOF) state) when either:

- four consecutive FAS are detected in error (i.e. \geq 1 error in each FAS);
- 986 or more frames with one or more BIP8 violations are detected in a block of 1 000 frames.

Frame alignment is deemed to have been recovered (entering In Frame (IF) state) when three consecutive non-errored FAS are found.

In the IF state even bit parity (BIP-8) is computed for each bit n of every byte of the preceding frame and compared with bit n of the EM byte recovered from the current frame. A difference between the computed BIP-8 and the EM value is taken as evidence of one or more errors in the previous frame.

NOTE 2: This process is identical with the BIP-8 violation process of the P31s_TT_Sk function. The process may be used in common for both functions.

Should a research for frame alignment be initiated either due to:

- a fortuitous FAS position being found once and not being found a second time in its expected position;
- exceeding the threshold which indicates false alignment;

then the new search for frame alignment should start 1 bit displaced forward from the position of the last indication of frame alignment.

NOTE 3: The above is required in order to avoid repeated alignment on to a simulation of the framing location.

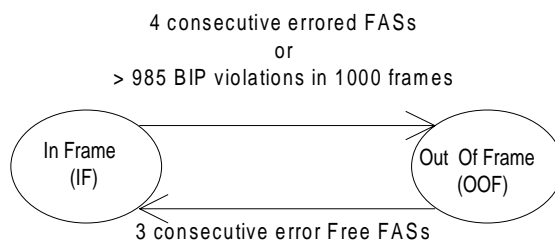

Figure 56: Frame alignment state diagram

Activation: The function shall perform the operation specified above when it is activated (MI_Active is true). Otherwise, it shall transmit the all-ONEs signal at its output (CI_D) and not report its status via the management point.

Defects:

If the frame alignment is deemed to be lost (OOF state), a 34 Mbit/s Loss Of Frame defect (dLOF) shall be detected. The dLOF defect shall be cleared when the frame alignment is deemed to have been recovered (IF state).

The dAIS defect shall be detected specified by EN 300 417-1-1 [8], subclause 8.2.1.7 for 34 Mbit/s, with $X = 7$, $Y = 4\ 296$, $Z = 8$.

Consequent Actions:

aAIS ← dAIS or dLOF or AI_TSF.

aSSF ← dAIS or dLOF or AI_TSF.

On declaration of aAIS the function shall output an all-ONEs (AIS) signal - complying to the frequency limits for this interface - within 250 μ s; on clearing of aAIS the function shall output normal data within 250 μ s.

Defect Correlations:

cAIS ← dAIS and (not AI_TSF) and AIS_Reported.

cLOF ← dLOF and (not dAIS) and (not AI_TSF).

Performance Monitoring: None.

11 E22 Section Layer Functions

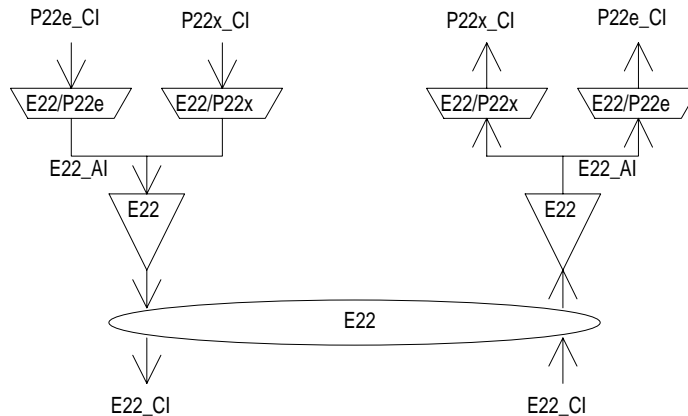

Figure 57: E22 Section atomic functions

E22 layer CP

The Characteristic Information E22_CI of the intra-station electrical CP is a digital, electrical signal of defined amplitude, bit rate and pulse shape specified by ETS 300 166 [4].

E22 layer AP

The information passing across the E22/P22x AP is a 8 448 kbit/s signal with co-directional bit timing.

The information passing across the E22/P22e AP is a 8 448 kbit/s signal with co-directional bit timing. It contains four 2 048 kbit/s tributary signals (see figure 58).

Figure 57 shows that more than one adaptation function exists in this E22 layer that can be connected to one E22 access point. For the case of the adaptation source functions, only one of these adaptation source functions is allowed to be activated. For this activated source, access to the access point by other adaptation source functions shall be denied. In contradiction with the source direction, adaptation sink functions may be activated all together. This may cause faults (e.g. cLOF) to be detected and reported. To prevent this an adaptation sink function can be deactivated.

NOTE: If one adaptation function only is connected to the AP, it will be activated. If one or more other functions are connected to the same AP, one out of the set of functions will be active.

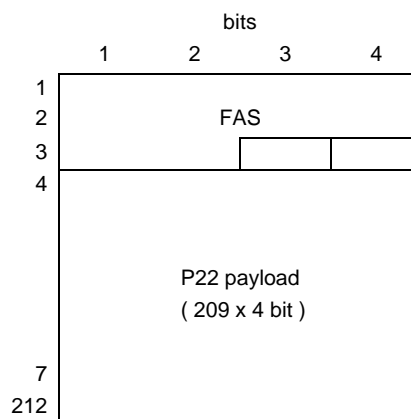

Figure 58: Decoded E22/P22e_AI_D signal

11.1 E22 Connection function E22_C

For further study.

11.2 E22 Trail Termination functions

11.2.1 E22 Trail Termination Source E22_TT_So

Symbol:

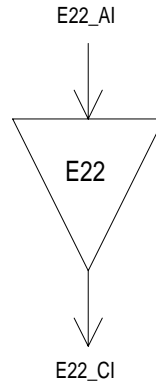

Figure 59: E22_TT_So symbol

Interfaces:

Table 33: E22_TT_So input and output signals

Input(s)	Output(s)
E22_AI_D	E22_CI_D

Processes:

This function generates the electrical Intra-station Section Layer signal E22 specified by ETS 300 166 [4].

Pulse shape: The function shall meet the requirement specified by ETS 300 166 [4].

Nominal Peak Voltage of a mark (pulse): The function shall meet the requirement specified by ETS 300 166 [4].

Peak voltage of a space (no pulse): The function shall meet the requirement specified by ETS 300 166 [4].

Nominal pulse width: The function shall meet the requirement specified by ETS 300 166 [4].

Ratio of the amplitudes of positive and negative pulses at the centre of the pulse interval: The function shall meet the requirement specified by ETS 300 166 [4].

Ratio of widths of positive and negative pulses at the nominal half amplitude: The function shall meet the requirement specified by ETS 300 166 [4].

Pair(s) in each direction: The function shall meet the requirement specified by ETS 300 166 [4].

Output return loss: The function shall meet the requirement specified by ETS 300 166 [4].

Defects: None.

Consequent Actions: None.

Defect Correlations: None.

Performance Monitoring: None.

11.2.2 E22 Trail Termination Sink E22_TT_Sk

Symbol:

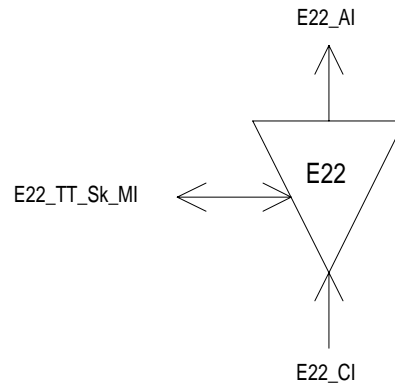

Figure 60: E22_TT_Sk symbol

Interfaces:

Table 34: E22_TT_Sk input and output signals

Input(s)	Output(s)
E22_CI_D	E22_AI_D E22_AI_TSF
E22_TT_Sk_MI_PortMode	E22_TT_Sk_MI_cLOS

Processes:

This function recovers the electrical Intra-station Section Layer signal E22 specified by ETS 300 166 [4].

Input return loss: The function shall meet the requirement specified by ETS 300 166 [4].

Port Mode: The function shall have a port mode as specified by subclause 8.5 of EN 300 417-1-1 [8].

NOTE: The AUTO state of the port mode process is optional.

Defects:

The function shall detect Loss Of Signal defect (dLOS) according the 8 448 kbit/s dLOS specification in subclause 8.2.1.6 of EN 300 417-1-1 [8].

Consequent Actions:

aTSF ← dLOS.

Defect Correlations:

cLOS ← MON and dLOS.

Performance Monitoring: None.

11.3 E22 Adaptation functions

11.3.1 E22 to P22x Adaptation Source E22/P22x_A_So

Symbol:

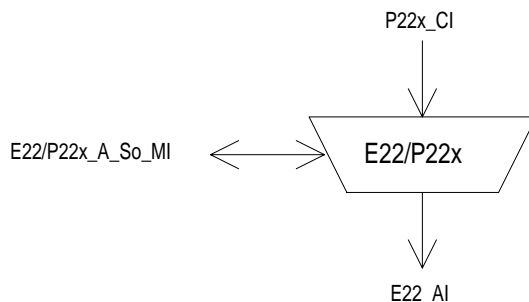

Figure 61: E22/P22x_A_So symbol

Interfaces:

Table 35: E22/P22x_A_So input and output signals

Input(s)	Output(s)
P22x_CI_D P22x_CI_CK E22/P22x_A_So_MI_Active	E22_AI_D

Processes:

This function provides the HDB3 encoding of the 8 448 kbit/s information stream specified by ETS 300 166 [4].

HDB3 encoder: The function shall perform HDB3 encoding of the data as specified in ETS 300 166 [4].

The function shall not add any jitter.

NOTE: Jitter at the NNI is the combination of the jitter generated and transferred via the client layers.

Activation: The function shall access the access point when it is activated (MI_Active is true). Otherwise, it shall not access the access point.

Defects: None.

Consequent Actions: None.

Defect Correlations: None.

Performance Monitoring: None.

11.3.2 E22 to P22x Adaptation Sink E22/P22x_A_Sk

Symbol:

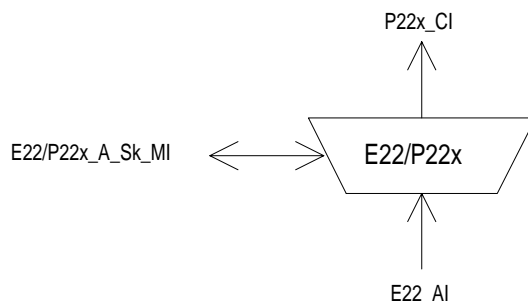

Figure 62: E22/P22x_A_Sk symbol

Interfaces:

Table 36: E22/P22x_A_Sk input and output signals

Input(s)	Output(s)
E22_AI_D E22_AI_TSF E22/P22x_A_Sk_MI_Active	P22x_CI_D P22x_CI_CK P22x_CI_SSF

Processes:

This function regenerates the received signal, recovers bit timing (CK) from the received signal, and decodes the incoming electrical 8 448 kbit/s E22 signal.

Regeneration: The function shall operate without any errors when any combination of the following signal conditions exist at the input:

- an input electrical amplitude level with any value in the range specified by ETS 300 166 [4];
- jitter modulation applied to the input signal with any value defined in ITU-T Recommendation G.823 [14];
- the input signal bit rate has any value in the range $8\,448\text{ kbit/s} \pm 30\text{ ppm}$;
- the input signal has an interfering signal specified by ETS 300 166 [4].

NOTE: The frequency and jitter / wander tolerance might be further constrained by the requirements of the client layers.

HDB3 decoding: The function shall perform the HDB3 decoding process specified by ETS 300 166 [4].

Activation: The function shall perform the operation specified above when it is activated (MI_Active is true). Otherwise, it shall transmit the all-ONES signal at its output (CI_D) and not report its status via the management point.

Defects: None.

Consequent Actions:

- aSSF ← AI_TSF.
- aAIS ← AI_TSF.

On declaration of aAIS the function shall output an all-ONES (AIS) signal - complying to the frequency limits for this interface - within 250 μs ; on clearing of aAIS the function shall output normal data within 250 μs .

Defect Correlations: None.

Performance Monitoring: None.

11.3.3 E22 to P22e Adaptation Source E22/P22e_A_So

Symbol:

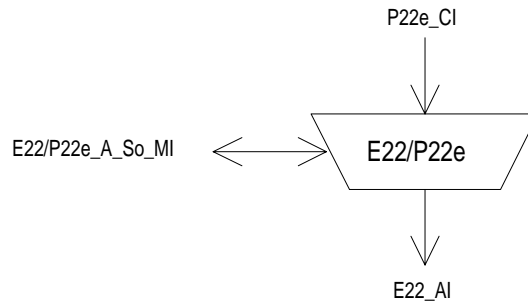

Figure 63: E22/P22e_A_So symbol

Interfaces:

Table 37: E22/P22e_A_So input and output signals

Input(s)	Output(s)
P22e_CI_D P22e_CI_CK E22/P22e_A_So_MI_Active	E22_AI_D

Processes:

This function performs HDB3 encoding of the 8 448 kbit/s signal.

HDB3 encoder: The function shall perform HDB3 encoding of the data as specified in ETS 300 166 [4].

The function shall not add any jitter.

NOTE: Jitter at the NNI is the combination of the jitter generated and transferred via the client layers.

Activation: The function shall access the access point when it is activated (MI_Active is true). Otherwise, it shall not access the access point.

Defects: None.

Consequent Actions: None.

Defect Correlations: None.

Performance Monitoring: None.

11.3.4 E22 to P22e Adaptation Sink E22/P22e_A_Sk

Symbol:

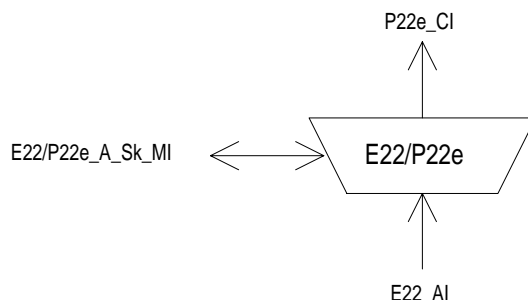

Figure 64: E22/P22e_A_Sk symbol

Interfaces:

Table 38: E22/P22e_A_Sk input and output signals

Input(s)	Output(s)
E22_AI_D	P22e_CI_D P22e_CI_CK P22e_CI_FS
E22_AI_TSF	P22e_CI_SSF
E22/P22e_A_Sk_MI_AIS_Reported	E22/P22e_A_Sk_MI_cLOF
E22/P22e_A_Sk_MI_Active	E22/P22e_A_Sk_MI_cAIS

Processes:

The function regenerates the received signal, recovers bit timing (CK) and Frame Start reference (FS) from the received signal, and decodes the incoming electrical 8 448 kbit/s E22 signal. It can be activated / deactivated when multiple adaptation function types are connected to the access point.

Regeneration: The function shall operate without any errors when any combination of the following signal conditions exist at the input:

- an input electrical amplitude level with any value in the range specified by ETS 300 166 [4];
- jitter modulation applied to the input signal with any value defined in ITU-T Recommendation G.823 [14];
- the input signal bit rate has any value in the range 8 448 kbit/s \pm 30 ppm;
- the input signal has an interfering signal specified by ETS 300 166 [4].

HDB3 decoding: The function shall perform the HDB3 decoding process specified by ETS 300 166 [4].

Frame alignment: The function shall perform the frame alignment of the 8 448 kbit/s signal to recover the frame start signal FS. Loss of frame alignment shall be assumed to have taken place when four consecutive frame alignment signals have been incorrectly received in their predicted positions.

When frame alignment is assumed to be lost, the frame alignment device shall decide that such alignment has effectively been recovered when it detects the presence of three consecutive frame alignment signals.

The frame alignment device having detected the appearance of a single correct frame alignment signal, shall begin a new search for the frame alignment signal when it detects the absence of the frame alignment signal in one of the two following frames.

Activation: The function shall perform the operation specified above when it is activated (MI_Active is true). Otherwise, it shall transmit the all-ONES signal at its output (CI_D) and not report its status via the management point.

Defects:

The function shall detect a loss of frame defect (dLOF) when four consecutive frame alignment signals have been incorrectly received in their predicted positions. When frame alignment is lost, the dLOF defect shall be cleared when three consecutive frame alignment signals are detected.

The function shall detect an AIS defect (dAIS) according the specification in subclause 8.2.1.7 of EN 300 417-1-1 [8], with $X = 4$, $Y = 848$, $Z = 5$.

Consequent Actions:

aAIS ← dAIS or dLOF or AI_TSF;

aSSF ← dAIS or dLOF or AI_TSF.

On declaration of aAIS the function shall output an all-ONEs (AIS) signal - complying to the frequency limits for this interface - within 250 μ s; on clearing of aAIS the function shall output normal data within 250 μ s.

Defect Correlations:

cAIS ← dAIS and (not AI_TSF) and AIS_Reported;

cLOF ← dLOF and (not dAIS) and (not AI_TSF).

Performance Monitoring: None.

12 E12 Section Layer Functions

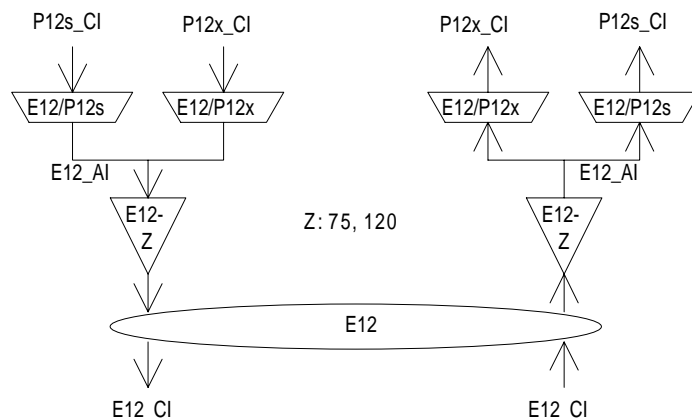

Figure 65: E12 Section atomic functions

E12 layer CP

The Characteristic Information E12_CI of the intra-station electrical CP is a digital, electrical signal of defined amplitude, bit rate, impedance and pulse shape specified by ETS 300 166 [4].

NOTE 1: The specification within the present document is limited to the Network Node Interface (NNI).

E12 layer AP

The information passing across the E12/P12x AP is a 2 048 kbit/s signal with co-directional bit timing.

The information passing across the E12/P12s AP is a 2 048 kbit/s signal with co-directional bit timing with a frame structure specified by ETS 300 167 [5] (see figures 66 and 67).

Figure 65 shows that more than one adaptation function exists in this E12 layer that can be connected to one E12 access point. For the case of the adaptation source functions, only one of these adaptation source functions is allowed to be activated. For this activated source, access to the access point by other adaptation source functions shall be denied. In contradiction with the source direction, adaptation sink functions may be activated all together. This may cause faults (e.g. cLOF) to be detected and reported. To prevent this an adaptation sink function can be deactivated.

NOTE 2: If one adaptation function only is connected to the AP, it will be activated. If one or more other functions are connected to the same AP, one out of the set of functions will be active.

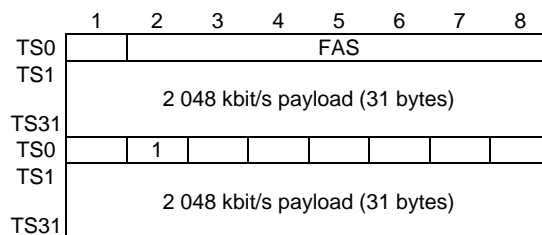

Figure 66: Decoded P12s_CI_D (without CRC-4 multiframe)

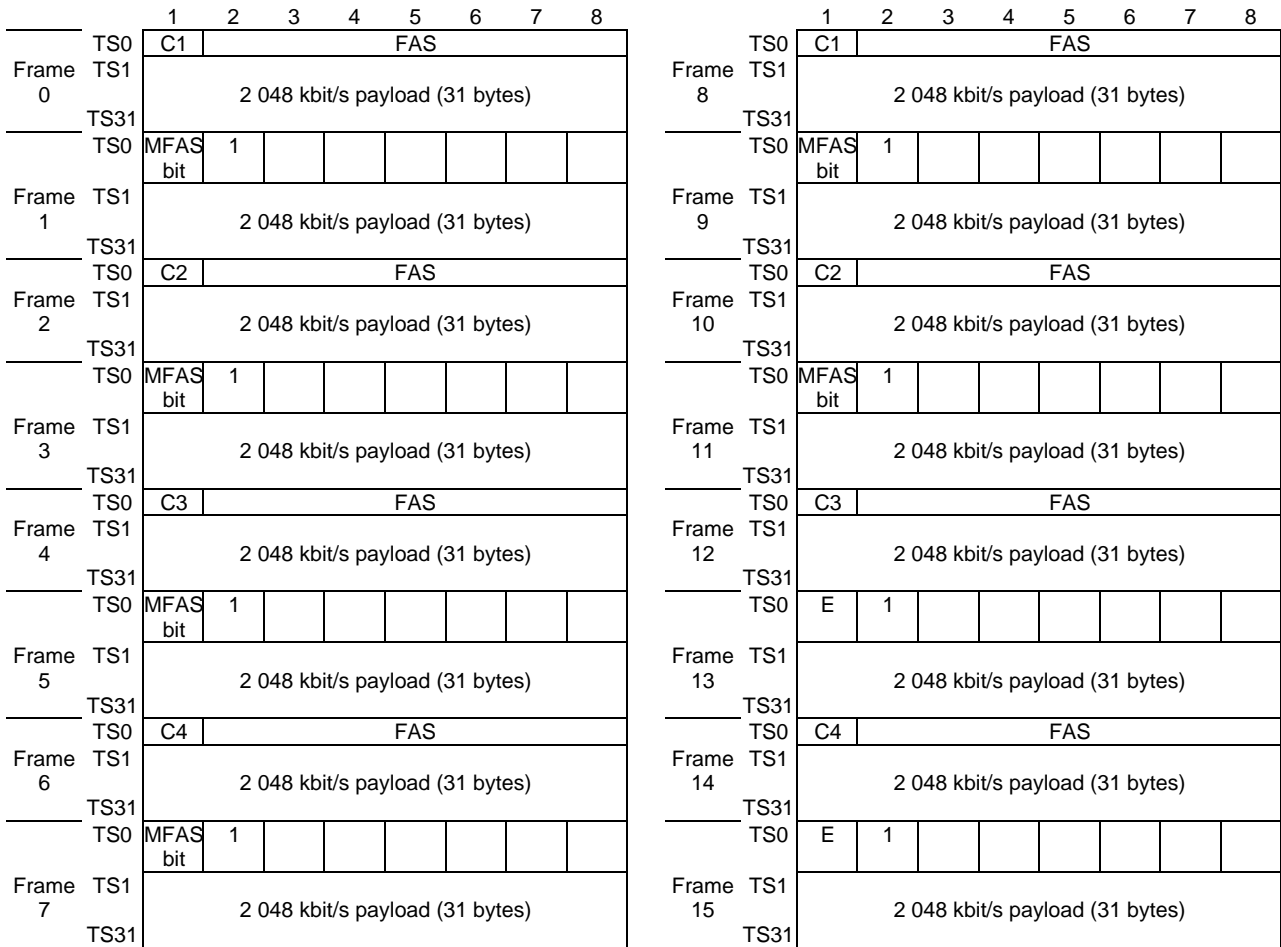

Figure 67: Decoded P12s_CI_D (with CRC-4 multiframe)

12.1 E12 Connection function E12_C

For further study.

12.2 E12 Trail Termination functions

12.2.1 E12 Trail Termination Source E12-Z_TT_So

NOTE: Z (Ω) will be one value out of the set: {75, 120} (Ω).

Symbol:

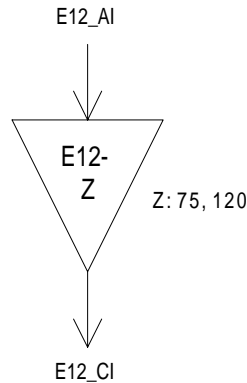

Figure 68: E12-Z_TT_So symbol

Interfaces:

Table 39: E12_TT_So input and output signals

Input(s)	Output(s)
E12_AI_D	E12_CI_D

Processes:

This function generates the electrical Intra-station Section Layer signal E12 specified by ETS 300 166 [4].

Pulse shape: The function shall meet the requirement specified by ETS 300 166 [4].

Nominal Peak Voltage of a mark (pulse): The function shall meet the requirement specified by ETS 300 166 [4].

Peak voltage of a space (no pulse): The function shall meet the requirement specified by ETS 300 166 [4].

Nominal pulse width: The function shall meet the requirement specified by ETS 300 166 [4].

Ratio of the amplitudes of positive and negative pulses at the centre of the pulse interval: The function shall meet the requirement specified by ETS 300 166 [4].

Ratio of widths of positive and negative pulses at the nominal half amplitude: The function shall meet the requirement specified by ETS 300 166 [4].

Pair(s) in each direction: The function shall meet the requirement specified by ETS 300 166 [4].

Output return loss: The function shall meet the requirement specified by ETS 300 166 [4].

Output signal balance: For the case of a 120 Ω interface, the function shall meet the requirement specified by ETS 300 166 [4].

Defects:	None.
Consequent Actions:	None.
Defect Correlations:	None.
Performance Monitoring:	None.

12.2.2 E12 Trail Termination Sink E12-Z_TT_Sk

NOTE: Z (Ω) will be one value out of the set: {75, 120} (Ω).

Symbol:

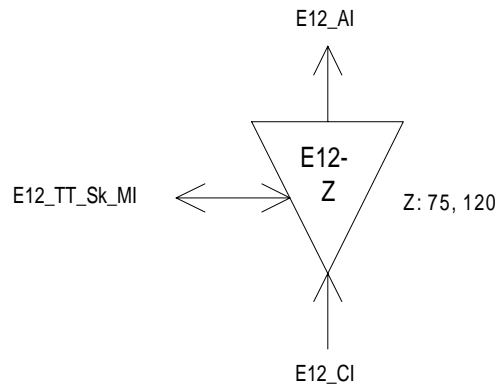

Figure 69: E12-Z_TT_Sk symbol

Interfaces:

Table 40: E12_TT_Sk input and output signals

Input(s)	Output(s)
E12_CI_D	E12_AI_D E12_AI_TSF
E12_TT_Sk_MI_PortMode	E12_TT_Sk_MI_cLOS

Processes:

This function recovers the electrical Intra-station Section Layer signal E12 specified by ETS 300 166 [4].

Input return loss: The function shall meet the requirement specified by ETS 300 166 [4].

Port Mode: The function shall have a port mode as specified by subclause 8.5 of EN 300 417-1-1 [8].

NOTE: The AUTO state of the port mode process is optional.

Defects:

The function shall detect Loss Of Signal defect (dLOS) according the 2 048 kbit/s dLOS specification in subclause 8.2.1.6 of EN 300 417-1-1 [8].

Consequent Actions:

aTSF ← dLOS.

Defect Correlations:

cLOS ← MON and dLOS.

Performance Monitoring: None.

12.3 E12 Adaptation functions

12.3.1 E12 to P12x Adaptation Source E12/P12x_A_So

Symbol:

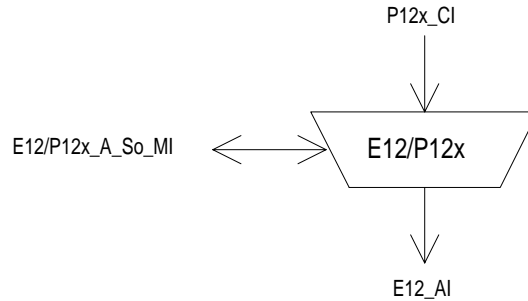

Figure 70: E12/P12x_A_So symbol

Interfaces:

Table 41: E12/P12x_A_So input and output signals

Input(s)	Output(s)
P12x_CI_D P12x_CI_CK E12/P12x_A_So_MI_Active	E12_AI_D

Processes:

This function provides the HDB3 encoding of the 2 048 kbit/s information stream specified by ETS 300 166 [4].

HDB3 encoder: The function shall perform HDB3 encoding of the data as specified in ETS 300 166 [4].

The function shall not add any jitter.

NOTE: Jitter at the NNI is the combination of the jitter generated and transferred via the client layers.

Activation: The function shall access the access point when it is activated (MI_Active is true). Otherwise, it shall not access the access point.

Defects: None.

Consequent Actions: None.

Defect Correlations: None.

Performance Monitoring: None.

12.3.2 E12 to P12x Adaptation Sink E12/P12x_A_Sk

Symbol:

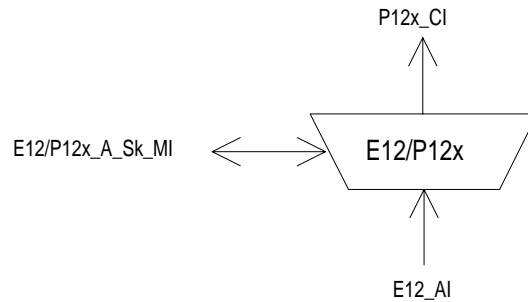

Figure 71: E12/P12x_A_Sk symbol

Interfaces:

Table 42: E12/P12x_A_Sk input and output signals

Input(s)	Output(s)
E12_AI_D E12_AI_TSF E12/P12x_A_Sk_MI_Active	P12x_CI_D P12x_CI_CK P12x_CI_SSF

Processes:

This function regenerates the received signal, recovers bit timing (CK) from the received signal, and decodes the incoming electrical 2 048 kbit/s E12 signal.

Regeneration: The function shall operate without any errors when any combination of the following signal conditions exist at the input:

- an input electrical amplitude level with any value in the range specified by ETS 300 166 [4];
- jitter modulation applied to the input signal with any value defined in ITU-T Recommendation G.823 [14];
- the input signal bit rate has any value in the range 2 048 kbit/s \pm 50 ppm;
- the input signal has an interfering signal specified by ETS 300 166 [4];
- for the case of a 120 Ω interface, the input signal has an longitudinal voltage specified by ETS 300 166 [4].

NOTE: The frequency and jitter / wander tolerance might be further constrained by the requirements of the client layers.

HDB3 decoding: The function shall perform the HDB3 decoding process specified by ETS 300 166 [4].

Activation: The function shall perform the operation specified above when it is activated (MI_Active is true). Otherwise, it shall transmit the all-ONES signal at its output (CI_D) and not report its status via the management point.

Defects: None.

Consequent Actions:

aSSF \leftarrow AI_TSF.
aAIS \leftarrow AI_TSF.

On declaration of aAIS the function shall output an all-ONES (AIS) signal - complying to the frequency limits for this interface (e.g. 2 048 kHz \pm 50 ppm, or nominal frequency) - within 250 μ s; on clearing of aAIS the function shall output normal data within 250 μ s.

Defect Correlations: None.

Performance Monitoring: None.

12.3.3 E12 to P12s Adaptation Source E12/P12s_A_So

Symbol:

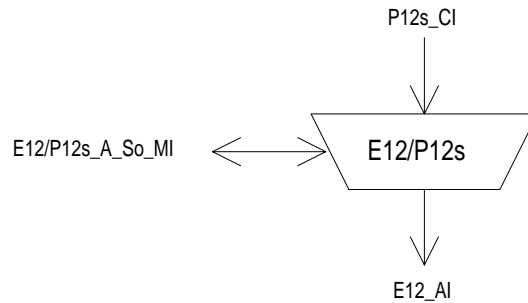

Figure 72: E12/P12s_A_So symbol

Interfaces:

Table 43: E12/P12s_So input and output signals

Input(s)	Output(s)
P12s_CI_D P12s_CI_CK E12/P12s_A_So_MI_Active	E12_AI_D

Processes:

This function provides HDB3 encoding of the 2 048 kbit/s P12s signal specified by ETS 300 166 [4].

HDB3 encoder: The function shall perform HDB3 encoding of the data as specified in ETS 300 166 [4].

The function shall not add any jitter.

NOTE: Jitter at the NNI is the combination of the jitter generated and transferred via the client layers.

Activation: The function shall access the access point when it is activated (MI_Active is true). Otherwise, it shall not access the access point.

Defects: None.

Consequent Actions: None.

Defect Correlations: None.

Performance Monitoring: None.

12.3.4 E12 to P12s Adaptation Sink E12/P12s_A_Sk

Symbol:

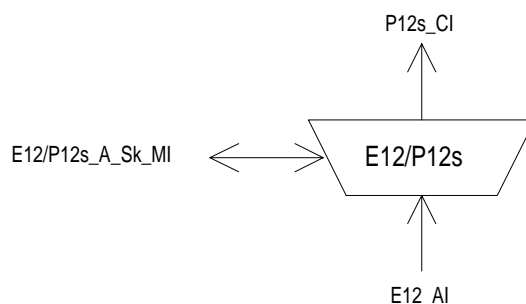

Figure 73: E12/P12s_A_Sk symbol

Interfaces:

Table 44: E12/P12s_Sk input and output signals

Input(s)	Output(s)
E12_AI_D	P12s_CI_D P12s_CI_CK
E12_AI_TSF	P12s_CI_FS P12s_CI_MFS P12s_CI_SSF
E12/P12s_A_Sk_MI_AIS_Reported	E12/P12s_A_Sk_MI_cLOF
E12/P12s_A_Sk_MI_Active	E12/P12s_A_Sk_MI_cAIS
E12/P12s_A_Sk_MI_CRC4mode	E12/P12s_A_Sk_MI_NCI

Processes:

The function regenerates the received signal, recovers bit timing (CK), decodes the incoming electrical 2 048 kbit/s E12 signal, and recovers Frame Start reference (FS).

Regeneration: The function shall operate without any errors when any combination of the following signal conditions exist at the input:

- an input electrical amplitude level with any value in the range specified by ETS 300 166 [4];
- jitter modulation applied to the input signal with any value defined in ITU-T Recommendation G.823 [14];
- the input signal bit rate has any value in the range 2 048 kbit/s \pm 50 ppm;
- the input signal has an interfering signal specified by ETS 300 166 [4];
- for the case of a 120 Ω interface, the input signal has an longitudinal voltage applied as specified by ETS 300 166 [4].

NOTE 1: The frequency and jitter / wander tolerance might be further constrained by the requirements of the client layers.

HDB3 decoding: The function shall perform the HDB3 decoding process specified by ETS 300 166 [4].

Basic frame and CRC-4 Multiframe alignment: The function shall recover the (250 μ s) basic frame and (2 ms) CRC-4 multiframe phase. The process shall operate as specified in ETS 300 167 [5]. Either the manual, or the automatic, or both manual and automatic interworking modes shall be supported.

NOTE 2: The frame alignment process in ETS 300 167 [5] is under study.

Activation: The function shall perform the operation specified above when it is activated (MI_Active is true). Otherwise, it shall transmit the all-ONEs signal at its output (CI_D) and not report its status via the management point.

Defects:

The function shall detect dLOF defect as specified by ETS 300 167 [5].

The function shall clear dLOF defect as specified by ETS 300 167 [5].

The function shall report NCI status in the automatic CRC-4 interworking mode as specified by ETS 300 167 [5].

The dAIS defect shall be detected specified by EN 300 417-1-1 [8], subclause 8.2.1.7 for 2 Mbit/s, with X = 2, Y = 512, Z = 3.

Consequent Actions:

aAIS ← dAIS or dLOF or AI_TSF.

aSSF ← dAIS or dLOF or AI_TSF.

On declaration of aAIS the function shall output an all-ONEs (AIS) signal - complying to the frequency limits for this interface - within 250 μ s; on clearing of aAIS the function shall output normal data within 250 μ s.

Defect Correlations:

cAIS ← dAIS and (not AI_TSF) and AIS_Reported.

cLOF ← dLOF and (not dAIS) and (not AI_TSF).

Performance Monitoring: None.

13 T12 Section Layer Functions

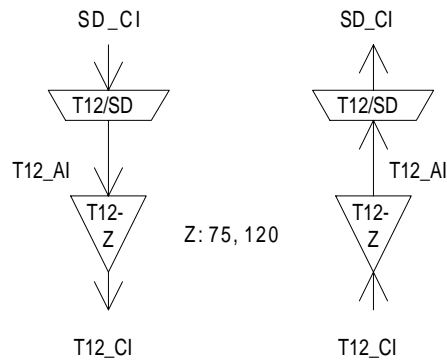

Figure 74: T12 Section atomic functions

T12 layer CP

The Characteristic Information T12_CI of the intra-station electrical layer CP is an electrical 2 048 kHz signal of defined amplitude, frequency and pulse shape specified by ETS 300 166 [4].

T12 layer AP

The information passing across the T12/SD AP is a 2 048 kHz synchronization signal.

13.1 T12 Connection function T12_C

Not applicable.

13.2 T12 Trail Termination functions

13.2.1 T12 Trail Termination Source T12-Z_TT_So

NOTE 1: Z (Ω) will be one value out of the set: {75, 120} (Ω).

Symbol:

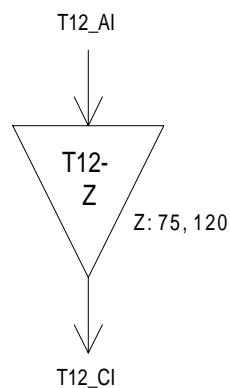

Figure 75: T12-Z_TT_So symbol

Interfaces:**Table 45: T12_TT_So input and output signals**

Input(s)	Output(s)
T12_AI_CK T12_AI_SQLCH	T12_CI_CK

Processes:

This function generates the electrical 2 048 kHz signal used for transmission of synchronization signals to an external equipment on a plesiochronous intra-station section specified by ETS 300 166 [4].

Pulse shape: The function shall meet the requirement specified by ETS 300 166 [4].

Maximum Peak Voltage: The function shall meet the requirement specified by ETS 300 166 [4].

Minimum peak voltage: The function shall meet the requirement specified by ETS 300 166 [4].

Pair in each direction: The function shall meet the requirement specified by ETS 300 166 [4].

Defects: None.

Consequent Actions:

On activation of T12_AI_SQLCH the function shall shutdown the output within 250 μ s; on clearing of T12_AI_SQLCH the function shall output normal signal within 250 μ s.

NOTE 2: For more details refer to EN 300 417-6-1 [9].

Defect Correlations: None.

Performance Monitoring: None.

13.2.2 T12 Trail Termination Sink T12-Z_TT_Sk

NOTE 1: Z (Ω) will be one value out of the set: {75, 120} (Ω).

Symbol:

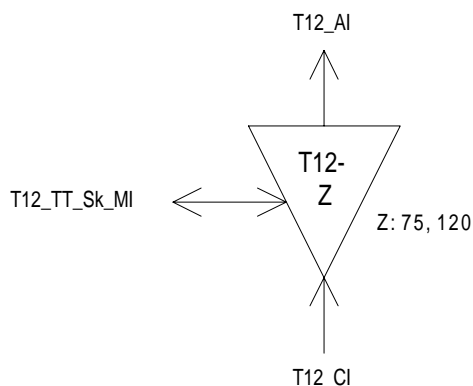

Figure 76: T12-Z_TT_Sk symbol

Interfaces:

Table 46: T12_TT_Sk input and output signals

Input(s)	Output(s)
T12_CI_CK	T12_AI_CK
	T12_AI_TSF
T12_TT_Sk_MI_PortMode	T12_TT_Sk_MI_cLOS

Processes:

This function recovers the electrical 2 048 kHz signal used for transmission of synchronization signals from an external equipment on a plesiochronous intra-station section specified by ETS 300 166 [4].

Input return loss: The function shall meet the requirement specified by ETS 300 166 [4].

Port Mode: The function shall have a port mode as specified by subclause 8.5 of EN 300 417-1-1 [8].

NOTE 2: The AUTO state of the port mode process is optional.

Defects:

The function shall detect 2 048 kHz Loss Of Signal defect (dLOS) as defined for the 2 048 kbit/s dLOS specification in subclause 8.2.1.6 of EN 300 417-1-1 [8].

Consequent Actions:

aTSF ← dLOS.

Defect Correlations:

cLOS ← MON and dLOS.

Performance Monitoring: None.

13.3 T12 Adaptation functions

13.3.1 T12 to SD Adaptation Source T12/SD_A_So

Refer to EN 300 417-6-1 [9].

13.3.2 T12 to SD Adaptation Sink T12/SD_A_Sk

Refer to EN 300 417-6-1 [9].

14 E0 Section Layer Functions

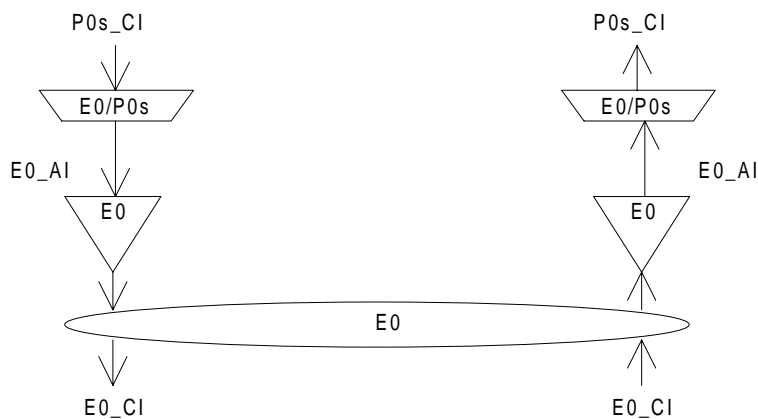

Figure 77: E0 Section atomic functions

E0 layer CP

The Characteristic Information E0_CI of the intra-station electrical layer CP is a digital, electrical 64 kbit/s co-directional signal set of defined amplitude, bit rate and pulse shape specified by ETS 300 166 [4].

E0 layer AP

The information passing across the E0/P0s AP is a synchronous 64 kbit/s signal with co-directional bit timing and octet identification.

14.1 E0 Connection function E0_C

For further study.

14.2 E0 Trail Termination functions

14.2.1 E0 Trail Termination Source E0_TT_So

Symbol:

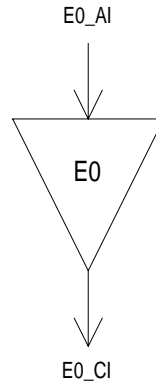

Figure 78: E0_TT_So symbol

Interfaces:

Table 47: E0_TT_So input and output signals

Input(s)	Output(s)
E0_AI_D	E0_CI_D

Processes:

This function generates the electrical 64 kbit/s co-directional Intra-station Section Layer signal E0 specified by ETS 300 166 [4].

Pulse shapes: The function shall meet the requirement specified by ETS 300 166 [4].

Peak to Peak Voltage: The function shall meet the requirement specified by ETS 300 166 [4].

Peak voltage of a space (no pulse): The function shall meet the requirement specified by ETS 300 166 [4].

Nominal pulse width: The function shall meet the requirement specified by ETS 300 166 [4].

Ratio of the amplitudes of positive and negative pulses at the centre of the pulse interval: The function shall meet the requirement specified by ETS 300 166 [4].

Ratio of widths of positive and negative pulses at the nominal half amplitude: The function shall meet the requirement specified by ETS 300 166 [4].

Pair(s) in each direction: The function shall meet the requirement specified by ETS 300 166 [4].

Output signal balance: The function shall meet the requirement specified by ETS 300 166 [4].

Output return loss: The function shall meet the requirement specified by ETS 300 166 [4].

Defects: None.

Consequent Actions: None.

Defect Correlations: None.

Performance Monitoring: None.

14.2.2 E0 Trail Termination Sink E0_TT_Sk

Symbol:

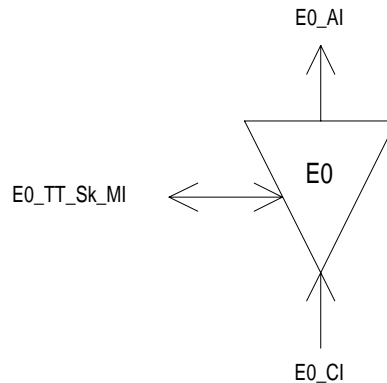

Figure 79: E0_TT_Sk symbol

Interfaces:

Table 48: E0_TT_Sk input and output signals

Input(s)	Output(s)
E0_CI_D	E0_AI_D
	E0_AI_TSF
E0_TT_Sk_MI_PortMode	E0_TT_Sk_MI_cLOS

Processes:

This function recovers the electrical Intra-station Section Layer signal E0 specified by ETS 300 166 [4].

Input return loss: The function shall meet the requirement specified by ETS 300 166 [4].

Impedance towards ground: The function shall meet the requirement specified by ETS 300 166 [4].

Port Mode: The function shall have a port mode as specified by subclause 8.5 of EN 300 417-1-1 [8].

NOTE 1: The AUTO state of the port mode process is optional.

Defects:

The function shall detect a Loss Of Signal defect (dLOS) according the 64 kbit/s dLOS specification in subclause 8.2.1.6 of EN 300 417-1-1 [8].

NOTE 2: An E0 interface used for OW or User Channel does not need to be monitored for loss of signal.

Consequent Actions:

aTSF ← dLOS.

Defect Correlations:

cLOS ← MON and dLOS.

Performance Monitoring: None.

14.3 E0 Adaptation functions

14.3.1 E0 to P0s Adaptation Source E0/P0s_A_So

Symbol:

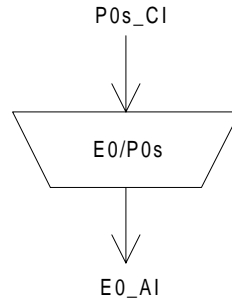

Figure 80: E0/P0s_A_So symbol

Interfaces:

Table 49: E0/P0s_A_So input and output signals

Input(s)	Output(s)
P0s_CI_D P0s_CI_CK P0s_CI_FS	E0_AI_D

Processes:

This function provides the encoding of the co-directional 64 kbit/s information stream specified by ETS 300 166 [4].

Encoder: The function shall perform encoding of the data as specified in ETS 300 166 [4].

The function shall not add any jitter.

NOTE: Jitter at the NNI is the combination of the jitter generated and transferred via the client layers.

Defects: None.

Consequent Actions: None.

Defect Correlations: None.

Performance Monitoring: None.

14.3.2 E0 to P0s Adaptation Sink E0/P0s_A_Sk

Symbol:

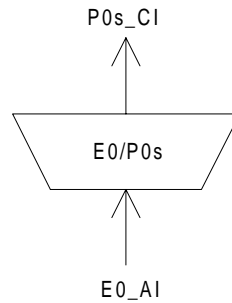

Figure 81: E0/P0s_A_Sk symbol

Interfaces:

Table 50: E0/P0s_A_Sk input and output signals

Input(s)	Output(s)
E0_AI_D E0_AI_TSF	P0s_CI_D P0s_CI_CK P0s_CI_FS P0s_CI_SSF

Processes:

This function regenerates the received signal, recovers bit timing (CK) and octet timing from the received signal, and decodes the incoming electrical co-directional 64 kbit/s E0 signal.

Regeneration: The function shall operate without any errors when any combination of the following signal conditions exist at the input:

- an input electrical amplitude level with any value in the range specified by ETS 300 166 [4];
- jitter modulation applied to the input signal with any value defined in ITU-T Recommendation G.823 [14];
- the input signal bit rate has any value in the range 64 kbit/s \pm 100 ppm;
- the input signal has an interfering signal specified by ETS 300 166 [4];
- the input signal has a longitudinal voltage applied as specified by ETS 300 166 [4].

NOTE 1: The frequency and jitter / wander tolerance might be further constrained by the requirements of the client layers.

Decoding and octet alignment: The function shall perform the decoding and octet alignment processes as specified in ETS 300 166 [4] for 64 kbit/s co-directional interfaces.

Defects: None.

NOTE 2: The addition of a Loss of Octet Timing defect (dLOT) is for further study.

Consequent Actions:

aAIS ← AI_TSF.

aSSF ← AI_TSF.

On declaration of aAIS the function shall output an all-ONEs (AIS) signal - complying to the frequency limits for this interface (e.g. 64 kHz \pm 100 ppm, or nominal frequency) - within 250 μ s; on clearing of aAIS the function shall output normal data within 250 μ s.

Defect Correlations: None.

Performance Monitoring: None.

Annex A (informative): E32 Section Layer Functions

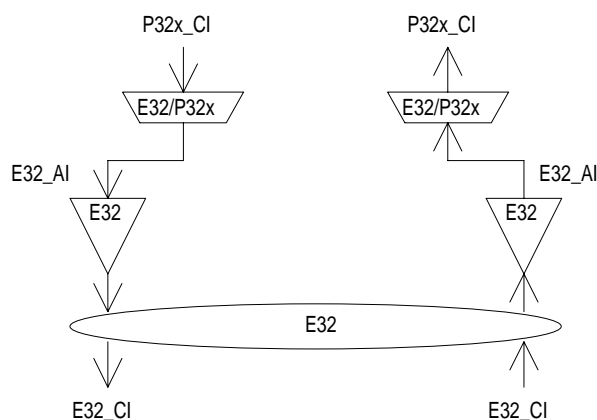

Figure A.1: E32 Section atomic functions

E32 layer CP

The Characteristic Information E32_CI of the intra-station electrical layer CP is a digital, electrical signal of defined amplitude, bit rate and pulse shape specified by ANSI T1.102 [1].

NOTE: The pulse shape defined in ANSI T1.102 [1] is for the signal at the digital distribution frame, not at the connector of the equipment.

E32 layer AP

The information passing across the E32/P32x AP is a 44 736 kbit/s signal with co-directional bit timing.

A.1 E32 Connection function E32_C

For further study.

A.2 E32 Trail Termination functions

A.2.1 E32 Trail Termination Source E32_TT_So

Symbol:

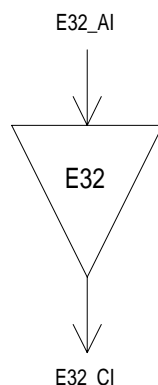

Figure A.2: E32_TT_So symbol

Interfaces:**Table A.1: E32_TT_So input and output signals**

Input(s)	Output(s)
E32_AI_D	E32_CI_D

Processes:

This function generates the electrical Intra-station Section Layer signal E32 specified by ANSI T1.102 [1].

The function shall meet the *medium, pulse amplitude, pulse shape, power level, pulse imbalance and DC power* requirements specified by ANSI T1.102 [1].

Defects: None.

Consequent Actions: None.

Defect Correlations: None.

Performance Monitoring: None.

A.2.2 E32 Trail Termination Sink E32_TT_Sk

Symbol:

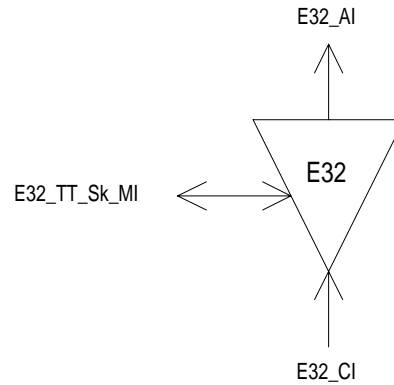

Figure A.3: E32_TT_Sk symbol

Interfaces:

Table A.2: E32_TT_Sk input and output signals

Input(s)	Output(s)
E32_CI_D	E32_AI_D E32_AI_TSF
E32_TT_Sk_MI_PortMode	E32_TT_Sk_MI_cLOS

Processes:

This function recovers the electrical Intra-station Section Layer signal E32 specified by ANSI T1.102 [1].

Port Mode: The function shall have a port mode as specified by subclause 8.5 of EN 300 417-1-1 [8].

NOTE: The AUTO state of the port mode process is optional.

Defects:

The function shall detect Loss Of Signal defect (dLOS) according the 44 736 kbit/s dLOS specification in ITU-T Recommendation G.775 [13].

Consequent Actions:

aTSF ← dLOS.

Defect Correlations:

cLOS ← MON and dLOS.

Performance Monitoring: None.

A.3 E32 Adaptation functions

A.3.1 E32 to P32x Adaptation Source E32/P32x_A_So

Symbol:

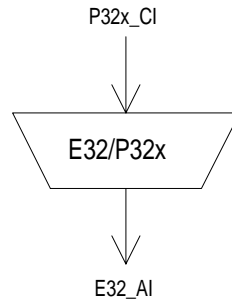

Figure A.4: E32/P32x_A_So symbol

Interfaces:

Table A.3: E32/P32x_A_So input and output signals

Input(s)	Output(s)
P32x_CI_D P32x_CI_CK	E32_AI_D

Processes:

This function provides the B3ZS encoding of the 44 736 kbit/s information stream specified by CCITT Recommendation G.703 [10].

B3ZS encoder: The function shall perform B3ZS encoding of the data specified by ANSI T1.102 [1].

The function shall not add any jitter.

NOTE: Jitter at the NNI is the combination of the jitter generated and transferred via the client layers.

Defects: None.

Consequent Actions: None.

Defect Correlations: None.

Performance Monitoring: None.

A.3.2 E32 to P32x Adaptation Sink E32/P32x_A_Sk

Symbol:

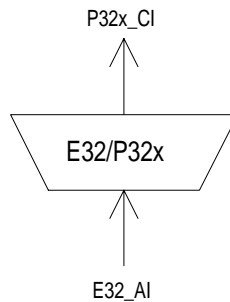

Figure A.5: E32/P32x_A_Sk symbol

Interfaces:

Table A.4: E32/P32x_A_Sk input and output signals

Input(s)	Output(s)
E32_AI_D E32_AI_TSF	P32x_CI_D P32x_CI_CK P32x_CI_SSF

Processes:

This function regenerates the received signal, recovers bit timing (CK) from the received signal, and decodes the incoming electrical 44 736 kbit/s E32 signal.

Regeneration: The function shall operate without any errors when any combination of the following signal conditions exist at the input:

- an input electrical amplitude level with any value in the range specified by ANSI T1.102 [1];
- jitter modulation applied to the input signal with any value specified by ANSI T1.102 [1];
- the input signal bit rate has any value in the range 44 736 kbit/s \pm 20 ppm.

NOTE: The frequency and jitter / wander tolerance might be further constrained by the requirements of the client layers.

B3ZS decoding: The function shall perform the B3ZS decoding process specified by ANSI T1.102 [1].

Defects: None.

Consequent Actions:

- aSSF ← AI_TSF.
- aAIS ← AI_TSF.

On declaration of aAIS the function shall output an AIS signal (see below for definition) - complying to the frequency limits for this interface - within 250 μ s; on clearing of aAIS the function shall output normal data within 250 μ s.

The AIS signal for this interface (as specified by ANSI T1.107 [2]) is a signal with valid M-frame alignment channel, M-subframe alignment channel and valid P bits. The information bits are set to a "10" sequence starting with a "1" after each M-frame alignment bit, X-bit, P-bit, and C-bit channel. The C-bits are set to "0". The X-bits are set to "1".

Defect Correlations: None.

Performance Monitoring: None.

Annex B (informative): E11 Section Layer Functions

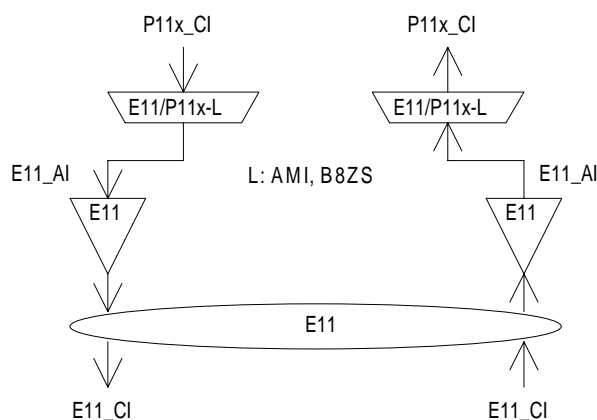

Figure B.1: E11 Section atomic functions

E11 layer CP

The Characteristic Information E11_CI of the intra-station electrical layer CP is a digital, electrical 1 544 kbit/s signal of defined amplitude, bit rate and pulse shape specified by ANSI T1.102 [1].

NOTE: The pulse shape defined in ANSI T1.102 [1] is for the signal at the digital distribution frame, not at the connector of the equipment.

E11 layer AP

The information passing across the E11/P11x AP is a 1 544 kbit/s signal with co-directional bit timing.

B.1 E11 Connection function E11_C

For further study.

B.2 E11 Trail Termination functions

B.2.1 E11 Trail Termination Source E11_TT_So

Symbol:

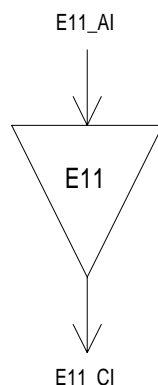

Figure B.2: E11_TT_So symbol

Interfaces:**Table B.1: E11_TT_So input and output signals**

Input(s)	Output(s)
E11_AI_D	E11_CI_D

Processes:

This function generates the electrical 1 544 kbit/s Intra-station Section Layer signal E11 specified by ANSI T1.102 [1].

The function shall meet the *medium, pulse amplitude, pulse shape, power level, pulse imbalance and DC power* requirements specified by ANSI T1.102 [1].

Defects: None.

Consequent Actions: None.

Defect Correlations: None.

Performance Monitoring: None.

B.2.2 E11 Trail Termination Sink E11_TT_Sk

Symbol:

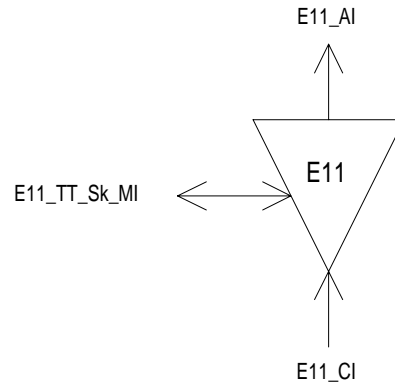

Figure B.3: E11_TT_Sk symbol

Interfaces:

Table B.2: E11_TT_Sk input and output signals

Input(s)	Output(s)
E11_CI_D	E11_AI_D E11_AI_TSF
E11_TT_Sk_MI_PortMode	E11_TT_Sk_MI_cLOS

Processes:

This function recovers the electrical 1 544 kbit/s Intra-station Section Layer signal E11 specified by ANSI T1.102 [1].

Port Mode: The function shall have a port mode as specified by subclause 8.5 of EN 300 417 -1-1 [8].

NOTE: The AUTO state of the port mode process is optional.

Defects:

The function shall detect Loss Of Signal defect (dLOS) according the 1 544 kbit/s dLOS specification in ITU-T Recommendation G.775 [13].

Consequent Actions:

aTSF ← dLOS.

Defect Correlations:

cLOS ← MON and dLOS.

Performance Monitoring: None.

B.3 E11 Adaptation functions

B.3.1 E11 to P11x Adaptation Source E11/P11x-L_A_So

NOTE 1: L will be one value out of the set: {AMI, B8ZS}.

Symbol:

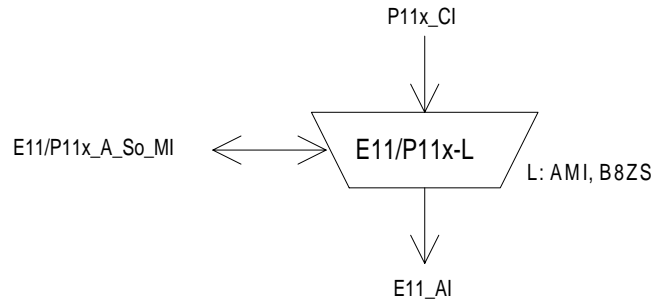

Figure B.4: E11/P11x-L_A_So symbol

Interfaces:

Table B.3: E11/P11x-L_A_So input and output signals

Input(s)	Output(s)
P11x_CI_D P11x_CI_CK E11/P11x_A_So_MI_Active	E11_AI_D

Processes:

This function provides the line encoding of the 1 544 kbit/s information stream specified by ANSI T1.102 [1].

Line encoder: The function shall perform line encoding of the data as specified ANSI T1.102 [1].

The function shall not add any jitter.

NOTE 2: Jitter at the NNI is the combination of the jitter generated and transferred via the client layers.

Defects: None.

Consequent Actions: None.

Defect Correlations: None.

Performance Monitoring: None.

B.3.2 E11 to P11x Adaptation Sink E11/P11x-L_A_Sk

NOTE 1: L will be one value out of the set: {AMI, B8ZS}.

Symbol:

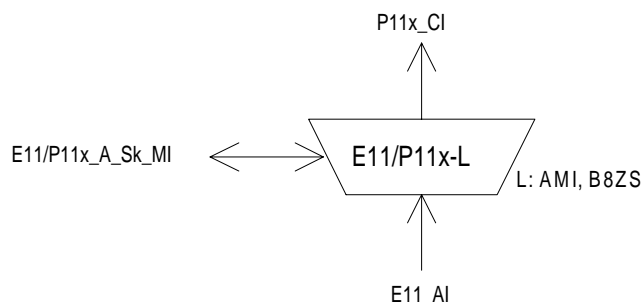

Figure B.5: E11/P11x_A_Sk symbol

Interfaces:

Table B.4: E11/P11x_A_Sk input and output signals

Input(s)	Output(s)
E11_AI_D	P11x_CI_D
E11_AI_TSF	P11x_CI_CK
E11/P11x_A_Sk_MI_Active	P11x_CI_SSF

Processes:

This function regenerates the received signal, recovers bit timing (CK) from the received signal, and decodes the incoming electrical 1 544 kbit/s E11 signal. It supplies the recovered timing signal to the synchronization distribution layer.

Regeneration: The function shall operate without any errors when any combination of the following signal conditions exist at the input:

- an input electrical amplitude level with any value in the range specified by ANSI T1.102 [1];
- jitter modulation applied to the input signal with any value specified by ANSI T1.102 [1];
- the input signal bit rate has any value in the range 1 544 kbit/s \pm 50 ppm.

NOTE 2: The frequency and jitter / wander tolerance might be further constrained by the requirements of the client layers.

Line decoding: The function shall perform the line decoding process specified by ANSI T1.102 [1].

Defects: None.

Consequent Actions:

aSSF \leftarrow AI_TSF.

aAIS \leftarrow AI_TSF.

On declaration of aAIS the function shall output an all-ONEs (AIS) signal - complying to the frequency limits for this interface (e.g. 1 544 kHz \pm 50 ppm) - within 250 μ s; on clearing of aAIS the function shall output normal data within 250 μ s.

Defect Correlations: None.

Performance Monitoring: None.

Bibliography

- ITU-T Recommendation V.11 (1993): "Electrical characteristics for balanced double-current interchange circuits operating at data signalling rates up to 10 Mbit/s".
- EN 300 462-3-1: "Transmission and Multiplexing (TM); Generic requirements for synchronization networks; Part 3: The control of jitter and wander within synchronization networks".

History

Document history		
Edition 1	April 1997	Publication as ETS 300 417-2-1
V1.1.2	November 1998	Publication (Converted to EN 300 417-2-1)
V1.1.3	May 1999	Publication