

# EN 300 417-1-1 V1.1.3 (1999-05)

---

*European Standard (Telecommunications series)*

**Transmission and Multiplexing (TM);  
Generic requirements of transport functionality of equipment;  
Part 1-1: Generic processes and performance**

---



---

Reference

REN/TM-01015-1-1a (3v099ie0.PDF)

---

Keywords

SDH, transmission, equipment practice,  
performance

**ETSI**

---

Postal address

F-06921 Sophia Antipolis Cedex - FRANCE

---

Office address

650 Route des Lucioles - Sophia Antipolis  
Valbonne - FRANCE  
Tel.: +33 4 92 94 42 00 Fax: +33 4 93 65 47 16  
Siret N° 348 623 562 00017 - NAF 742 C  
Association à but non lucratif enregistrée à la  
Sous-Préfecture de Grasse (06) N° 7803/88

---

Internet

secretariat@etsi.fr  
Individual copies of this ETSI deliverable  
can be downloaded from  
<http://www.etsi.org>  
If you find errors in the present document, send your  
comment to: editor@etsi.fr

---

**Copyright Notification**

No part may be reproduced except as authorized by written permission.  
The copyright and the foregoing restriction extend to reproduction in all media.

© European Telecommunications Standards Institute 1999.  
All rights reserved.

# Contents

Intellectual Property Rights .....	7
Foreword .....	7
1 Scope.....	9
2 References .....	10
3 Abbreviations, definitions, naming and numbering conventions .....	11
3.1 Abbreviations.....	11
3.2 Definitions .....	16
3.3 Naming and numbering conventions.....	19
3.3.1 Bit numbering scheme.....	19
3.3.2 STM-N SOH byte numbering scheme.....	19
3.3.3 Atomic function naming scheme .....	19
3.3.4 Information naming scheme .....	20
3.3.5 AU/TU numbering scheme.....	20
3.3.6 Reference points numbering scheme.....	23
3.3.7 Tributary port numbering scheme .....	23
3.3.8 PU numbering scheme.....	24
3.3.9 Supervision variables numbering scheme.....	25
3.4 Symbols and diagrammatic conventions.....	25
4 Introduction.....	27
4.1 Functional modelling rationale .....	28
4.1.1 Description of network elements - equipment functional specification.....	28
4.1.2 Implementation independence.....	28
4.1.3 Universal representation for management .....	28
4.2 The underlying principles of functional modelling.....	29
4.2.1 The client-server relationship.....	29
4.2.2 Atomic functions and compound functions .....	29
4.2.3 Network functions included in specific equipment .....	29
4.2.4 The functional model and the information model .....	29
5 Network layering principles .....	30
5.1 Transmission layers .....	30
5.2 Atomic functions.....	31
5.2.1 Connection function .....	32
5.2.2 Trail termination function .....	33
5.2.3 Adaptation function.....	34
5.3 Reference points .....	35
5.4 Transmission sub-layers.....	35
6 Combination rules.....	36
6.1 General.....	36
6.1.1 Binding at connection points.....	36
6.1.2 Binding at (termination) connection points .....	36
6.1.3 Binding at APs .....	37
6.1.4 Alternative binding representations.....	37
6.2 Directionality .....	37
6.3 Compound functions.....	38
6.4 Major compound functions .....	38
6.5 Trail, (sub)network connections, link connections, matrix connections, and tandem connections .....	39
6.6 Matrix connections .....	39
6.6.1 1-port.....	40
6.6.2 2-port.....	40
6.6.3 3-port.....	41
6.6.4 4-port.....	42

7	Maintenance signals and processes .....	42
7.1	Trail Trace Identifier (TTI).....	42
7.2	Trail Signal Label (TSL).....	44
7.2.1	Unequipped signal application .....	44
7.2.2	Supervisory-unequipped signal application.....	45
7.2.3	Adaptation function selection supervision process.....	46
7.2.4	Connection monitoring application .....	47
7.3	Error Detection Code (EDC) .....	47
7.4	Remote indicators .....	47
7.4.1	Remote Defect Indicator (RDI) .....	47
7.4.2	Remote Error Indicator (REI) .....	48
7.5	Alarm Indication Signal (AIS) .....	49
7.6	Non-intrusive monitoring of characteristic information at connection points.....	52
7.7	Signal fail and signal degrade .....	53
7.7.1	Server Signal Fail (aSSF) signal.....	53
7.7.2	Server Signal Fail failure (fSSF) .....	53
7.7.3	Server Signal Degrade (aSSD) signal.....	53
7.7.4	Trail Signal Fail (aTSF) signal.....	53
7.7.5	Trail Signal Degrade (aTSD) signal.....	54
8	Supervision process .....	54
8.1	Introduction .....	54
8.2	Atomic function fault management .....	56
8.2.1	Defect filter f1 .....	57
8.2.1.1	Introduction .....	57
8.2.1.2	Trail Signal Label (TSL) and unequipped .....	57
8.2.1.3	Trail Trace Identifier (TTI) .....	59
8.2.1.4	Degraded (DEG).....	60
8.2.1.5	Remote Defect Indicator (RDI) .....	60
8.2.1.6	Loss of signal.....	61
8.2.1.7	Alarm Indication Signal (AIS).....	61
8.2.1.8	Loss of frame, multiframe, pointer .....	62
8.2.1.9	Failure of protocol .....	62
8.2.1.10	Equipment defects .....	62
8.2.1.11	Transmit Fail .....	62
8.2.2	Consequent action filter f2 .....	62
8.2.2.1	Alarm Indication Signal (AIS).....	64
8.2.2.2	Remote Defect Indicator (RDI) .....	65
8.2.2.3	Remote Error Indication (REI) .....	65
8.2.2.4	Server Signal Fail (SSF) .....	65
8.2.2.5	Trail Signal Fail (TSF) .....	66
8.2.2.6	Trail Signal Degrade (TSD) .....	66
8.2.2.7	Unequipped Virtual Container (VC) signal .....	66
8.2.2.8	Unit Failure (UF).....	66
8.2.2.9	(Automatic) laser shutdown (ALS/LS) .....	66
8.2.2.10	Server Signal Degrade (SSD) .....	67
8.2.3	Fault cause filter f3.....	67
8.2.3.1	Termination sink function.....	67
8.2.3.2	Termination supervisory sink function .....	68
8.2.3.3	Adaptation sink function.....	68
8.2.3.4	Connection function.....	68
8.2.4	Performance monitoring filter f11 (pN_EBC).....	69
8.2.5	Performance monitoring filter f12 (pN_DS) .....	69
8.2.6	Performance monitoring filter f21 (pF_EBC) .....	69
8.2.7	Performance monitoring filter f22 (pF_DS).....	69
8.2.8	Other performance monitoring parameters (pOFS, pPSC, pPJE) .....	69
8.3	Equipment management function fault management process.....	70
8.3.1	Failure filter f4 .....	70
8.3.2	Replaceable unit alarm filter f5 .....	70
8.3.3	Network element alarm filter f6 .....	71
8.3.4	Station alarm filter f7 .....	71

8.3.5	Failure report filter f8.....	71
8.4	Equipment Management Function (EMF) performance monitoring process.....	71
8.4.1	PM filter f13 (N_ES).....	72
8.4.2	PM filter f23 (F_ES).....	72
8.4.3	PM filter f14 (N_SES).....	72
8.4.4	PM filter f24 (F_SES).....	73
8.4.5	PM filter f15 (N_UAT_cmd).....	73
8.4.6	PM filter f25 (F_UAT_cmd).....	73
8.4.7	PM filter f16 (N_BBE).....	73
8.4.8	PM filter f26 (F_BBE).....	73
8.4.9	PM filter f31 (history management).....	73
8.5	Trail termination point mode and port mode.....	74
9	Protection process.....	75
9.1	Introduction.....	75
9.2	General.....	75
9.2.1	Protection architectures.....	77
9.2.2	Switching types.....	78
9.2.2.1	APS channel provisioning.....	78
9.2.2.2	APS channel usage.....	78
9.2.2.3	APS channel coding.....	79
9.2.3	Operation types.....	79
9.2.4	Protection switch requests.....	79
9.2.5	Protection switch performance.....	79
9.2.6	Protection switch state machine.....	79
9.2.7	Protection connection function (I/O and processes).....	80
9.3	Trail protection class.....	80
9.3.1	Linear trail protection.....	80
9.3.2	SPRING protection.....	82
9.3.3	DPRING protection.....	84
9.4	SNC protection class.....	85
9.4.1	Inherently monitored SNC (SNC/I) protection.....	85
9.4.2	Non-intrusively monitored SNC (SNC/N) protection.....	86
9.4.3	Tandem connection protection.....	86
9.5	Equipment protection.....	86
10	Timing processes.....	87
10.1	Introduction.....	87
10.2	Synchronization timing collection.....	87
10.2.1	External synchronization reference inputs.....	88
10.2.2	Internal synchronization reference input.....	88
10.3	Synchronization timing selection and processing.....	88
10.3.1	Synchronization reference source selection.....	88
10.3.2	Clock processing.....	88
10.4	Synchronization timing distribution.....	89
10.4.1	Internal synchronization distribution interfaces.....	89
10.4.2	Synchronization reference outputs.....	89
10.5	Inter atomic function timing.....	89
10.6	AIS timing.....	90
11	General performance.....	91
11.1	Availability objectives.....	91
11.1.1	General.....	91
11.1.2	Parameters.....	91
11.1.3	Derivation of MTBF values.....	92
11.2	Transfer delay.....	92
11.3	Jitter and wander.....	93
11.3.1	Jitter and wander generation.....	93
11.3.1.1	Jitter and wander generation on STM-N signals.....	93
11.3.1.2	Jitter and wander generation on PDH interfaces.....	93
11.3.1.3	Jitter and wander generation on 2 048 kHz or 2 048 kbit/s synchronization interfaces.....	95

11.3.2	Jitter and wander tolerance.....	95
11.3.2.1	Jitter and wander tolerance on optical interfaces.....	95
11.3.2.2	Jitter and wander tolerance on traffic carrying electrical interfaces.....	95
11.3.2.3	Jitter and wander tolerance on 2 048 kHz and 2 048 kbit/s synchronization interfaces.....	95
11.3.3	Jitter and wander transfer functions.....	96
11.3.4	Performance on synchronization reference change-over.....	96
11.4	Error performance.....	96
11.5	Blocking factor.....	96
11.6	Connection set-up time.....	96
<b>Annex A (normative):</b>	<b>Pointer generation.....</b>	<b>97</b>
<b>Annex B (normative):</b>	<b>Pointer interpretation.....</b>	<b>99</b>
<b>Annex C (informative):</b>	<b>Network "production rules".....</b>	<b>103</b>
<b>Annex D (informative):</b>	<b>Flexible assignment of tributary port to VC-12 capacity.....</b>	<b>105</b>
<b>Annex E (informative):</b>	<b>Relationship between TU-2/12 address, and location of columns within a VC-4.....</b>	<b>106</b>
<b>Annex F (informative):</b>	<b>Performance monitoring history process.....</b>	<b>108</b>
<b>Annex G (informative):</b>	<b>Protection switch examples.....</b>	<b>110</b>
	Bibliography.....	111
	History.....	112

---

# Intellectual Property Rights

IPRs essential or potentially essential to the present document may have been declared to ETSI. The information pertaining to these essential IPRs, if any, is publicly available for **ETSI members and non-members**, and can be found in SR 000 314: "*Intellectual Property Rights (IPRs); Essential, or potentially Essential, IPRs notified to ETSI in respect of ETSI standards*", which is available **free of charge** from the ETSI Secretariat. Latest updates are available on the ETSI Web server (<http://www.etsi.org/ipr>).

Pursuant to the ETSI IPR Policy, no investigation, including IPR searches, has been carried out by ETSI. No guarantee can be given as to the existence of other IPRs not referenced in SR 000 314 (or the updates on the ETSI Web server) which are, or may be, or may become, essential to the present document.

---

## Foreword

This European Standard (Telecommunications series) has been produced by ETSI Technical Committee Transmission and Multiplexing (TM).

The present document is one of a family of documents that has been produced in order to provide inter-vendor and inter-operator compatibility of Synchronous Digital Hierarchy (SDH) equipment.

The present document is part 1-1 of a multi-part EN covering the generic requirements of transport functionality of equipment, as identified below:

**Part 1-1: "Generic processes and performance".**

Part 1-2: "General information about Implementation Conformance Statement (ICS) proforma".

Part 2-1: "Synchronous Digital Hierarchy (SDH) and Plesiochronous Digital Hierarchy (PDH) physical section layer functions".

Part 2-2: "Synchronous Digital Hierarchy (SDH) and Plesiochronous Digital Hierarchy (PDH) physical section layer functions; Implementation Conformance Statement (ICS) proforma specification".

Part 3-1: "Synchronous Transport Module-N (STM-N) regenerator and multiplex section layer functions".

Part 3-2: "Synchronous Transport Module-N (STM-N) regenerator and multiplex section layer functions; Implementation Conformance Statement (ICS) proforma specification".

Part 4-1: "Synchronous Digital Hierarchy (SDH) path layer functions".

Part 4-2: "Synchronous Digital Hierarchy (SDH) path layer functions; Implementation Conformance Statement (ICS) proforma specification".

Part 5-1: "Plesiochronous Digital Hierarchy (PDH) path layer functions".

Part 5-2: "Plesiochronous Digital Hierarchy (PDH) path layer functions; Implementation Conformance Statement (ICS) proforma specification".

Part 6-1: "Synchronization layer functions".

Part 6-2: "Synchronization layer functions; Implementation Conformance Statement (ICS) proforma specification".

Part 7-1: "Auxiliary layer functions".

Part 7-2: "Auxiliary layer functions; Implementation Conformance Statement (ICS) proforma specification".

Parts 2 to 7 specify the layers and their atomic functions.

NOTE 1: The present document does not currently address configuration management.

NOTE 2: The SDH radio equipment functional blocks are addressed by ETSI WG TM4.

Various of the above parts have previously been published as parts of ETS 300 417.

They have been converted into parts of EN 300 417 without technical changes, but some editorial changes have been necessary (e.g. references). In particular:

- Parts 2-1, 2-2 and 3-2 have been modified to take account of editorial errors present in edition 1.
- Part 1-1 has had its title change of to align with other parts published at a later date.

Also note that in the meantime parts 8-1 and 8-2 together with all parts x-3 (Abstract Test Suites) have been stopped.

This version of the present document has been published because the previous version had incorrect dates in the transposition table.

<b>National transposition dates</b>	
Date of latest announcement of this EN (doa):	31 August 1999
Date of latest publication of new National Standard or endorsement of this EN (dop/e):	29 February 2000
Date of withdrawal of any conflicting National Standard (dow):	29 February 2000



# 1 Scope

The present document specifies a library of basic building blocks and a set of rules by which they may be combined in order to describe a digital transmission equipment. The library comprises the functional building blocks needed to specify completely the generic functional structure of the European digital transmission hierarchy. In order to be compliant with the present document, equipment needs to be describable as an interconnection of a subset of these functional blocks contained within the present document. The interconnections of these blocks should obey the combination rules given.

The present document specifies both the components and the methodology that should be used in order to specify SDH equipment; it does not specify an individual SDH equipment as such.

The specification method is based on functional decomposition of the equipment into atomic, compound and major compound functions. The equipment is then described by its Equipment Functional Specification (EFS) which lists the constituent atomic and compound functions, their interconnection, and any overall performance objectives (e.g. transfer delay, availability, etc.). The concept is illustrated in figure 1.

The internal structure of the implementation of this functionality (equipment design) need not be identical to the structure of the functional model, as long as all the details of the externally observable behaviour comply with the EFS.

The equipment functionality is consistent with the SDH multiplexing structure given in ETS 300 147 [1].

Equipment developed prior to the production of the present document may not comply in all details with the present document.

Equipment which is normally stated to be compliant with the present document may not fulfil all the requirements in the case that it is interworking with old equipment that is not compliant with the present document.

The structure of the present document envisages the addition of new layers, atomic functions and (major) compound functions. For example, Asynchronous Transfer Mode (ATM), Integrated Services Digital Network (ISDN) and  $n \times 64$  kbit/s layers could be added as new complete parts while corresponding adaptation functions are added to existing layers. "SDH interworking" functionality can be added as new layers in part 5. This approach allows for short development times for standards describing new functionality.

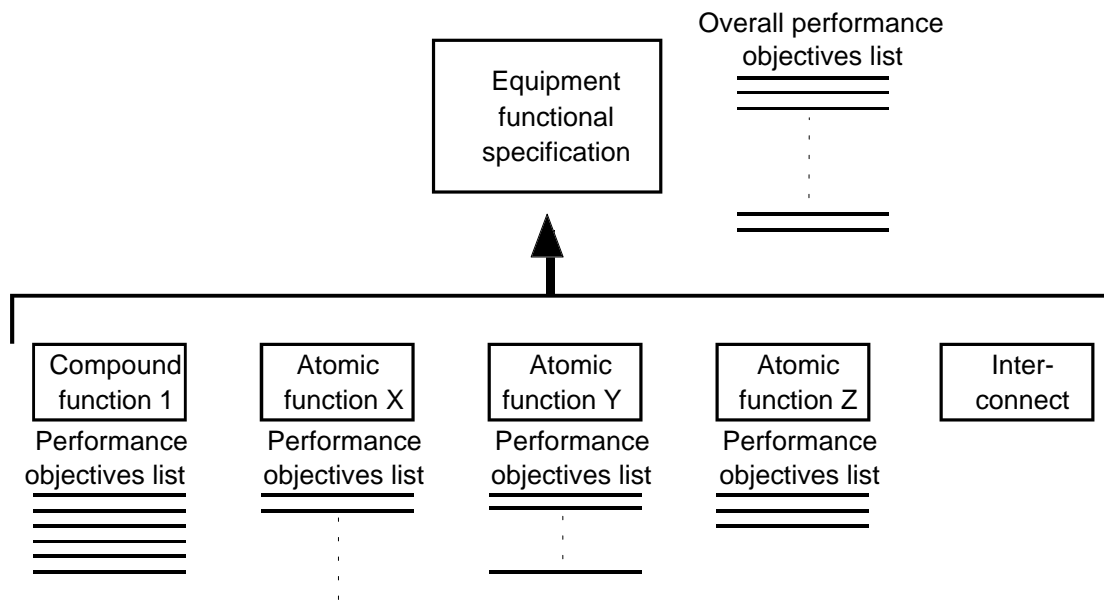

**Figure 1: Composition of equipment functional specification**

---

## 2 References

The following documents contain provisions which, through reference in this text, constitute provisions of the present document.

- References are either specific (identified by date of publication, edition number, version number, etc.) or non-specific.
- For a specific reference, subsequent revisions do not apply.
- For a non-specific reference, the latest version applies.
- A non-specific reference to an ETS shall also be taken to refer to later versions published as an EN with the same number.

- [1] ETS 300 147 (1995): "Transmission and Multiplexing (TM); Synchronous Digital Hierarchy (SDH); Multiplexing structure".
- [2] ETS 300 232: "Transmission and Multiplexing (TM); Optical interfaces for equipments and systems relating to the Synchronous Digital Hierarchy [ITU-T Recommendation G.957 (1993) modified]".
- [3] ETS 300 304: "Transmission and Multiplexing (TM); Synchronous Digital Hierarchy (SDH); SDH information model for the Network Element (NE) view".
- [4] ETS 300 019: "Equipment Engineering (EE); Environmental conditions and environmental tests for telecommunications equipment".
- [5] EN 300 462-2-1: "Transmission and Multiplexing (TM); Generic requirements for synchronization networks; Part 2-1: Synchronization network architecture".
- [6] ITU-T Recommendation G.803 (1993): "Architecture of transport networks based on the synchronous digital hierarchy (SDH)".
- [7] CCITT Recommendation G.703 (1991): "Physical / electrical characteristics of hierarchical digital interfaces".
- [8] ITU-T Recommendation G.704 (1995): "Synchronous frame structures used at 1 544, 6 312, 2 048, 8 488 and 44 736 kbit/s hierarchical levels".
- [9] CCITT Recommendation G.742 (1988): "Second order digital multiplex equipment operating at 8 448 kbit/s and using positive justification".
- [10] CCITT Recommendation G.751 (1988): "Digital multiplex equipments operating at the third order bit rate of 34 368 kbit/s and the fourth order bit rate of 139 264 kbit/s and using positive justification".
- [11] ITU-T Recommendation G.957 (1995): "Optical interfaces for equipments and systems relating to the synchronous digital hierarchy".
- [12] ITU-T Recommendation G.783 (1994): "Characteristics of Synchronous Digital Hierarchy (SDH) equipment functional blocks".
- [13] ITU-T Recommendation G.811 (1988): "Timing requirements at the outputs of primary reference clocks suitable for plesiochronous operation of international digital links".
- [14] CCITT Recommendation G.821 (1988): "Error performance of an international digital connection forming part of an integrated services digital network".
- [15] CCITT Recommendation G.823 (1988) modified according COM XVIII - R. report: "The control of jitter and wander within digital networks which are based on the 2 048 kbit/s hierarchy".
- [16] ITU-T Recommendation G.825 (1993): "The control of jitter and wander within digital networks which are based on the synchronous digital hierarchy (SDH)".

- [17] ITU-T Recommendation G.826 (1993): "Error performance parameters and objectives for international, constant bit rate digital paths at or above the primary rate".
- [18] ITU-T Recommendation G.958 (1994): "Digital line systems based on the synchronous digital hierarchy for use on optical cables".
- [19] ITU-T Recommendation G.911 (1993): "Parameters and calculation methodologies for reliability and availability of fibre optic systems".
- [20] CCITT Recommendation E.862 (1992): "Dependability planning of telecommunication networks".
- [21] CCITT Recommendation X.721 (1992): "Information technology - Open Systems Interconnection - Structure of Management Information: Definition of management information".
- [22] ITU-T Recommendation G.707 (1996): "Network node interface for the Synchronous Digital Hierarchy (SDH)".
- [23] CCITT Recommendation M.20 (1992): "Maintenance philosophy for telecommunications networks".
- [24] CCITT Recommendation M.2120 (1992): "Digital path, section and transmission system fault detection and localization procedures".
- [25] ITU-T Recommendation G.784 (1994): "Synchronous Digital Hierarchy (SDH) management".
- [26] EN 300 462-5-1: "Transmission and Multiplexing (TM); Generic requirements for synchronization networks; Part 5: Timing characteristics of slave clocks suitable for operation in Synchronous Digital Hierarchy (SDH) equipment".

---

## 3 Abbreviations, definitions, naming and numbering conventions

### 3.1 Abbreviations

For the purposes of the present document the following abbreviations apply:

A	Adaptation function
AcSL	Accepted Signal Label
AcTI	Accepted Trace identifier
ADM	Add-Drop Multiplexer
AI	Adapted Information
AIS	Alarm Indication Signal
ALS	Automatic Laser Shutdown
AP	Access Point
APId	Access Point Identifier
APS	Automatic Protection Switch
ATM	Asynchronous Transfer Mode
AU	Administrative Unit
AU-n	Administrative Unit, level n
AUG	Administrative Unit Group
BBE	Background Block Error
BBER	Background Block Error Ratio
BER	Bit Error Ratio
BFA	Basic Frame Alignment
BIP	Bit Interleaved Parity
BIP-N	Bit Interleaved Parity, width N
BITS	Building Integrated Timing Supply
BNF	Backus-Naur Form
BSHR	Bi-directional Self Healing Ring

C	Connection function
Cs	supervisory-unequipped Connection function
CH	Channel
CI	Characteristic Information
CK	Clock
CM	Connection Matrix
CMI	Coded Mark Inversion
Ctrl	Control
Co	Connection
CP	Connection Point
CRC	Cyclic Redundancy Check
CRC-N	Cyclic Redundancy Check, width N
CSES	Consecutive Severely Errored Seconds
CTF	Compound Timing Function
D	Data
DCC	Data Communications Channel
DEC	Decrement
DEG	Degraded
DEGTHR	Degraded Threshold
DL	Data Link
DPRING	Dedicated Protection Ring
DROP	Decreased Received Optical Power
DXC	Digital Cross Connect
E0	Electrical interface signal 64 kbit/s
E11	Electrical interface signal 1 544 kbit/s
E12	Electrical interface signal 2 048 kbit/s
E22	Electrical interface signal 8 448 kbit/s
E31	Electrical interface signal 34 368 kbit/s
E32	Electrical interface signal 44 736 kbit/s
E4	Electrical interface signal 139 264 kbit/s
EBC	Errored Block Count
ECC	Embedded Communications Channel
ECC(x)	Embedded Communications Channel, Layer x
EDC	Error Detection Code
EDCV	Error Detection Code Violation
EFS	Equipment Functional Specification
EMF	Equipment Management Function
EPS	Equipment Protection Switch
EQ	Equipment
ERS	Elementary Regenerator Section
ES	Errored Second
ES	Electrical Section
ESR	Errored seconds Ratio
Ex	CCITT Recommendation G.703 type electrical signal, bit rate order x
ExSL	Expected Signal Label
ExTI	Expected Trace Identifier
F_B	Far-end Block
F_BBE	Far-end Background Block Error
F_DS	Far-end Defect Second
F_EBC	Far-end Errored Block Count
F_ES	Far-end Errored Second
F_SES	Far-end Severely Errored Second
F_SESTHR	Far-end Severely Errored Second Threshold
F_UAT_cmd	Far-end UnAvailable Time command
FAS	Frame Alignment Signal
FEBE	Far End Block Error
FERF	Far End Receive Failure
FIFO	First In First Out
FIT	Failure In Time
FO	Frame Offset information

FOP	Failure Of Protocol
FS	Frame Start signal
HDB3	High Density Bipolar of order 3
HDLC	High-level Data Link Control procedure
HO	Higher Order
HOVC	Higher Order Virtual Container
HP	Higher order Path
ID	Identifier
IF	In Frame state
INC	Increment
IOS	Intra-Office Section
IS	Intermediate System
ISDN	Integrated Services Digital Network
ISO	International Standardization Organization
LAN	Local Area Network
LBC	Laser Bias Current
LC	Link Connection
LLC	Logical Link Control
LMC	Laser Modulation Current
LO	Lower Order
LOA	Loss Of Alignment; generic for LOF, LOM, LOP
LOF	Loss Of Frame
LOM	Loss Of Multiframe
LOP	Loss Of Pointer
LOS	Loss Of Signal
LOVC	Lower Order Virtual Container
LPx	Lower order Path for VC-x (x = 11, 12, 2, 3)
LT	Line Termination
M&CF	Management & Communication Function
MC	Matrix Connection
MCF	Message Communications Function
MDT	Mean Down Time
mei	maintenance event information
MI	Management Information
MO	Managed Object
MON	Monitored
MP	Management Point
MS	Multiplex Section
MS1	STM-1 Multiplex Section
MS4	STM-4 Multiplex Section
MS16	STM-16 Multiplex Section
MSB	Most Significant Bit
MSOH	Multiplex Section Overhead
MSP	Multiplex Section Protection
MSPG	Multiplex Section Protection Group
MTBF	Mean Time Between Failures
MTTR	Mean Time To Repair
N_B	Near-end Block
N_BBE	Near-end Background Block Error
N_DS	Near-end Defect Second
N_EBC	Near-end Errored Block Count
N_ES	Near-end Errored Second
N_SES	Near-end Severely Errored Second
N_SESTHR	Near-end Severely Errored Second Threshold
N_UAT_cmd	Near-end UnAvailable Time command
NC	Network Connection
N.C.	Not Connected
NCM	No CRC-4 Multiframe alignment signal
NDF	New Data Flag
NE	Network Element

NNI	Network Node Interface
NMON	Not Monitored
NPDU	Network Protocol Data Unit
NRZ	Non-Return to Zero
NRZI	Non-Return to Zero Inverted
NSAP	Network Service Access Point
NU	National Use (bits, bytes)
NUx	National Use, bit rate order x
OAM	Operation, Administration and Management
OFS	Out of Frame Second
OOF	Out Of Frame state
OS	Optical Section
OS	Operations System
OSC	Oscillator
OSI(x)	Open Systems Interconnection, Layer x
OW	Order Wire
P	Protection
P_A	Protection Adaptation
P_C	Protection Connection
P_TT	Protection Trail Termination
P0x	64 kbit/s layer (transparent)
P0_31c	1 984 kbit/s layer
P11x	1 544 kbit/s layer (transparent)
P12s	2 048 kbit/s PDH path layer with synchronous 125 µs frame structure according to ETS 300 167
P12x	2 048 kbit/s layer (transparent)
P22e	8 448 kbit/s PDH path layer with 4 plesiochronous 2 048 kbit/s
P22x	8 448 kbit/s layer (transparent)
P31e	34 368 kbit/s PDH path layer with 4 plesiochronous 8 448 kbit/s
P31s	34 368 kbit/s PDH path layer with synchronous 125 µs frame structure according to ETS 300 337
P31x	34 368 kbit/s layer (transparent)
P32x	44 736 kbit/s layer (transparent)
P4e	139 264 kbit/s PDH path layer with 4 plesiochronous 34 368 kbit/s
P4s	139 264 kbit/s PDH path layer with synchronous 125 µs frame structure according to ETS 300 337
P4x	139 264 kbit/s layer (transparent)
PDC	Photo Diode Current
PDH	Plesiochronous Digital Hierarchy
PJE	Pointer Justification Event
PLM	Payload Mismatch
PM	Performance Monitoring
Pn	Plesiochronous signal, Level n
POH	Path Overhead
PRC	Primary Reference Clock
PS	Protection Switching
PSC	Protection Switch Count
PSV	Power Supply Voltage
PTR	Pointer
PU	PDH Unit
QOS	Quality Of Service
RDI	Remote Defect Indicator
REI	Remote Error Indicator
RI	Remote Information
RLT	Regenerated Line Termination
RP	Remote Point
RS	Regenerator Section
RS1	STM-1 Regenerator Section
RS4	STM-4 Regenerator Section
RS16	STM-16 Regenerator Section
RSOH	Regenerator Section Overhead
RTG	Regenerator Timing Generator
RTR	Reset Threshold Report

RxSL	Received Signal Label
RxTI	Received Trace identifier
S11	VC-11 path layer
S12	VC-12 path layer
S2	VC-2 path layer
S3	VC-3 path layer
S4	VC-4 path layer
SASE	Stand-Alone Synchronization Equipment
SD	Synchronization Distribution layer, Signal Degrade
SD-2	2 048 kbit/s based timing source reference
SD-C	2 048 kHz based timing source reference
SD-N	STM-N based timing source reference
SDA	Synchronization Distribution Adaptation
SDH	Synchronous Digital Hierarchy
SDT	Synchronization Distribution Termination
SEC	SDH Equipment Clock
SES	Severely Errored Second
SESR	Severely Errored seconds Ratio
SF	Signal Fail
SHR	Self Healing Ring
Sk	Sink
SLM	Signal Label Mismatch
SMF	Sub-Multi Frame
SMUX	Synchronous Multiplexer
SNC	Sub-Network Connection
SNC/I	Inherently monitored Sub-Network Connection protection
SNC/N	Non-intrusively monitored Sub-Network Connection protection
So	Source
SOH	Section Overhead
SPRING	Shared Protection Ring
SSD	Server Signal Degrade
SSF	Server Signal Fail
SSM	Synchronization Status Message
SSU	Synchronization Supply Unit
STM	Synchronous Transport Module
STM-N	Synchronous Transport Module, level N
T12	2 048 kHz signal
TCA	Threshold Crossing Alert
TCF	Timing Connection Function
TCN	Threshold Crossing Notification
TCP	Termination Connection Point
TD	Transmit Degrade
TF	Transmit Fail
TFAS	trail Trace identifier Frame Alignment Signal
TG	Timing Generator
TIM	Trace Identifier Mismatch
TI	Timing Information
TM	Transmission_Medium, Transmission & Multiplexing
TMN	Telecommunications Management Network
TP	Timing Point
TPmode	Termination Point mode
TPS	Transmission Protection Switch
TR	Threshold Report
TS	Time Slot
TSD	Trail Signal Degrade
TSF	Trail Signal Fail
TSL	Trail Signal Label
TT	Trail Termination function
TTs	Trail Termination supervisory function
TTI	Trail Trace Identifier

TTP	Trail Termination Point
TU	Tributary Unit
TU-m	Tributary Unit, level m
TUG	Tributary Unit Group
TUG-m	Tributary Unit Group, level m
TxSL	Transmitted Signal Label
TxTI	Transmitted Trace Identifier
UAS	UnAvailable Second
UAT	UnAvailable Time
UAT_cmd	UnAvailable Time command
UNEQ	Unequipped
UF	Unit Failure
UNI	User Network Interface
URLT	Unregenerated Line Termination
USR	User channels
UVC	Unequipped VC
VC	Virtual Container
VC-n	Virtual Container, level n
VMR	Violation Monitoring and Removal
VP	Virtual Path
W	Working

## 3.2 Definitions

For the purposes of the present document, the following definitions apply:

**process:** A generic term for an action or a collection of actions.

**function:** A "process" defined for digital transmission hierarchies (e.g. Plesiochronous Digital Hierarchy (PDH), SDH) which acts on a collection of input information to produce a collection of output information. A function is distinguished by the way in which characteristics of the collection, or of members of the collection of output information differ from characteristics of members of the collection of input information.

**atomic function:** A "function" which if divided into simpler "functions" would cease to be uniquely defined for digital transmission hierarchies. It is therefore indivisible from a network point of view. The following atomic functions are defined in each network layer:

- bi-directional Trail Termination function (...\_TT), Trail Termination Source function (...\_TT\_So), Trail Termination Sink function (...\_TT\_Sk) and Connection function (...\_Co);
- between client and server layer networks three adaptation functions are defined: Adaptation Sink function ...\_A\_Sk, Adaptation Source function ...\_A\_So, and the bi-directional Adaptation function ...\_A.

**adaptation function:** An "atomic function" which passes a collection of information between layer networks by changing the way in which the collection of information is represented.

**trail termination function:** An "atomic function" within a "layer" which generates, adds, and monitors information concerning the integrity and supervision of "adapted information".

**connection function:** An "atomic function" within a layer which, if connectivity exists, relays a collection of items of information between groups of atomic functions. It does not modify the members of this collection of items of information although it may terminate any switching protocol information and act upon it. Any connectivity restrictions between inputs and outputs shall be stated.

**compound function:** A "function" which represents a collection of "atomic functions" within one layer.

EXAMPLE 1: A combination of several atomic adaptation functions within a certain layer (each serving one client layer) is a compound adaptation function. A combination of a (compound) adaptation function and the layer's termination function is a compound function.

**major compound function:** A "function" which represents a collection of "atomic functions" and/or "compound functions" within more than one "layer".



**EXAMPLE 2:** The atomic functions in the Optical Section (OS), Multiplex Section (MS) and Regenerator Section (RS) layers may be combined to form a major compound function.

The (major) compound functions facilitate simplified descriptions of equipment. Standardized (major) compound functions attach a unique name to a common combination of atomic functions.

**equipment functional specification:** A collection of atomic, compound, or major compound functions and any overall performance objectives which describe the functionality of an equipment.

**layer:** A concept used to allow the transport network functionality to be described hierarchically as successive levels; each layer being solely concerned with the generation and transfer of its "characteristic information".

**client / server layer:** Any two adjacent network layers are associated in a client / server relationship. Each transport network layer provides transport to the layer above and uses transport from the layers below. The layer providing transport is termed a "server", the layer using transport is termed "client".

**grooming:** The allocation of server layer trails to client layer connections which groups together client layer connections whose characteristics are similar or related.

Thus it is possible to groom Virtual Container, level 12 (VC-12) paths by service type, by destination, or by protection category in to particular VC-4 paths which can then be managed accordingly. It is also possible to groom VC-4 paths according to similar criteria into Synchronous Transport Module (STM-N) sections.

**consolidation:** The allocation of server layer trails to client layer connections which ensures that each server layer trail is full before the next is allocated. Consolidation minimizes the number of partially filled server layer trails. It therefore maximizes the "fill factor".

Thus a number of partially filled VC-4 paths may be consolidated into a single, fully filled VC-4.

**Remote Defect Indicator (RDI):** A signal which conveys the defect status of the characteristic information received by the Trail Termination sink function back to the network element which contains the characteristic information originating trail termination source function.

Examples of RDI signals are the Far End Receive Failure (FERF) bit(s) in SDH signals, the A-bit in ITU-T Recommendation G.704 [8] structured 2 048 kbit/s signals and the alarm indication bit in other PDH multiplex signals.

**Remote Error Indication (REI):** A signal which conveys either the exact or truncated number of error detection code violations within the characteristic information (as detected by the trail termination sink function) back to the network element which contains the characteristic information originating trail termination source function.

Examples of REI signals are the Far End Block Error (FEBE) bit(s) in SDH signals and the E-bit in ITU-T Recommendation G.704 [8] structured 2 048 kbit/s signals.

**PDH Unit (PU):** A PDH tributary signal and its associated justification control bits which are contained in a PDH aggregate signal.

**All-ONES:** The entire capacity of the adapted or characteristic information is set to logic "1".

**MS-AIS:** An STM-N signal (at the Network Node Interface (NNI)) in which the entire capacity is set to logic "1" with the exception of the Regenerator Section Overhead (RSOH).

**AU4-AIS:** An STM-N signal (at the NNI) in which the entire capacity of an Administrative Unit 4 (AU-4) is set to logic "1".

**TU-m-AIS:** An STM-N signal (at the NNI) in which the entire capacity of a TU-m is set to logic "1".

**PUx-AIS:** A PDH aggregate signal (at the NNI) in which the entire tributary signal is set to logic "1" and the associated justification control information is correct.

NOTE 1: Unequipped VC and supervisory-unequipped VC definitions are given in subclause 7.2.

**Characteristic Information (CI):** A signal of specific rate and format which is transferred within and between "sub-networks", and presented to an "adaptation" function for "transport" by the server layer network.

**Remote Information (RI):** Information flow from sink direction to source direction of the same atomic function in unidirectional representation, containing information to be transported to the remote end, such as RDI and REI.

**reference point:** The delimiter of a "function".

**Access Point (AP):** A "reference point" where the output of an "adaptation" source function is bound to the input of a "Trail Termination source", or where the output of a "trail termination sink" is bound to the input of an "adaptation" sink function. The "access point" is characterized by the adapted client layer "characteristic information" which passes across it. A bi-directional "access point" is formed by an associated contra-directional pair.

**Connection Point (CP):** A "reference point" where the output of a "trail termination source" or a "connection" is bound to the input of another "connection", or where the output of a "connection" is bound to the input of a "trail termination sink" or another "connection". The "connection point" is characterized by the information which passes across it. A bi-directional "connection point" is formed by the association of a contra-directional pair.

NOTE 2: In the information model the connection point is called Connection Termination Point (CTP).

**Termination Connection Point (TCP):** A special case of a "connection point" where a "trail termination" function is bound to an "adaptation" function or a "connection" function.

NOTE 3: In the information model the termination connection point is called Trail Termination Point (TTP).

**timing point:** A "reference point" where an output of the synchronization distribution layer is bound to the input of an adaptation source or connection function, or where the output of an adaptation sink function is bound to an input of the synchronization distribution layer.

**management point (MP):** A "reference point" where the output of an atomic function is bound to the input of the element management function, or where the output of the element management function is bound to the input of an atomic function.

NOTE 4: The MP is not the TMN Q3 interface.

**fault (see note 5):** A fault is the inability of a function to perform a required action. This does not include an inability due to preventive maintenance, lack of external resources, or planned actions.

NOTE 5: The definitions of fault, anomaly, defect, fault cause, failure, and alarm are derived from ITU-T Recommendation M.20 [23]. Since ITU-T Recommendation M.20 [23] is open to some differences in interpretation, some words have been amended to express how terminology is used in the present document.

**anomaly:** The smallest discrepancy which can be observed between the actual and desired characteristics of an item. The occurrence of a single anomaly does not constitute an interruption in the ability to perform a required function. Anomalies are used as the input for the Performance Monitoring (PM) process and for the detection of defects.

**defect:** The density of anomalies has reached a level where the ability to perform a required function has been interrupted. Defects are used as input for PM, the control of consequent actions, and the determination of fault cause.

**fault cause:** A single disturbance or fault may lead to the detection of multiple defects. A fault cause is the result of a correlation process which is intended to pinpoint the defect that is representative of the disturbance or fault that is causing the problem.

**failure:** The fault cause persisted long enough to consider the ability of an item to perform a required function to be terminated. The item may be considered as failed; a fault has now been detected.

**alarm:** A human observable indication that draws attention to a failure (detected fault) usually giving an indication of the severity of the fault.

**blocking factor:** The blocking factor of a connection matrix is the probability that a particular connection request cannot be met, normally expressed as a decimal fraction of 1.

**routing:** The process whereby a number of connection functions within the same layer are configured to provide a trail between defined termination points.

**undefined bit:** If a bit is undefined, its value is set to a logical "0" or a logical "1".

**undefined byte:** If a byte is undefined, it contains eight undefined bits.

NOTE 6: In future, it may be a requirement to fix undefined bits to logical "0".

### 3.3 Naming and numbering conventions

#### 3.3.1 Bit numbering scheme

Within each byte bit 1 denotes the most significant bit and is transmitted (or received) first. The most significant bit (bit 1) is illustrated on the left and the least significant bit (bit 8) on the right in all diagrams (see figure 2).

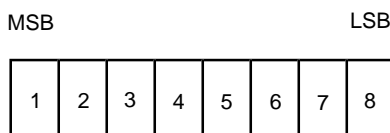

Figure 2: Bit numbering scheme

#### 3.3.2 STM-N SOH byte numbering scheme

The regenerator and multiplex section layers are defined for each of the three Synchronous Transport Module (STM) rates defined in ETS 300 147 [1]. Some of the overhead bytes are reserved for future standardization. As they have not been specifically dedicated to any particular layer existing, or to be defined, they have for the present been allocated as follows: those in row 1 of the Section Overhead (SOH) to the optical layer; those in rows 2 and 3 to the RS layer and those in rows 5-9 to the MS layer. The TT source functions in these layers are defined to set those bytes to the default values.

The location of those SOH bytes within an STM-N frame is identified by a two co-ordinate vector (ROW, COL) where ROW represents the row number (1.....9) and COL represents the column co-ordinate (1....9×N). Figure 3 shows the SOH byte positions in an STM-N frame.

NOTE: A three co-ordinate vector S(a,b,c) could be used (but is not recommended) with the following relation: ROW = a, COL = N (b-1) + c, a = ROW, b = COL div N, c = COL mod N.

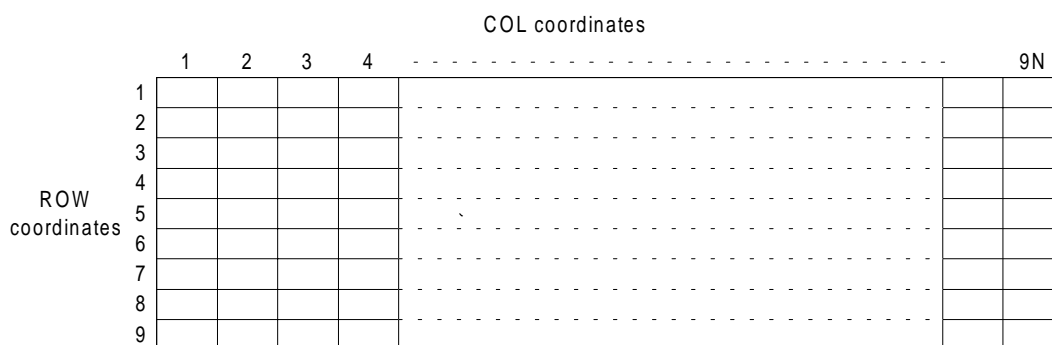

Figure 3: SOH byte numbering in a STM-N frame

#### 3.3.3 Atomic function naming scheme

The naming of adaptation, trail termination and connection **functions** follow the following rules:

Adaptation function            <layer>/<client layer>\_A[<direction>]

Trail Termination function   <layer>\_TT[<direction>]

Connection function           <layer>\_C

Examples are:    MS1/S4\_A, S12/P12s\_A\_So, P4e\_TT, RS16\_TT\_Sk, S3\_C.

### 3.3.4 Information naming scheme

The coding of the **CI** and Adapted Information (**AI**) in the model follows the following rules:

**<layer>[/<client layer>] \_<information type>[ \_<direction>] \_<signal type>[/<number>].**

[ ... ]	optional term
<layer>	represents one of the layer names (e.g. RS1)
<client layer>	represents one of the client layer names (e.g. MS1 is a client of RS1)
<information type>	CI or AI
<direction>	So (Source) or Sk (Sink)
<signal type>	CK (clock), or D (data), or FS (Frame Start), or SSF (Server Signal Fail), or TSF (Trail Signal Fail) SSD (Server Signal Degrade) TSD (Trail Signal Degrade)
<number>	see below

AI and CI coding examples are: MS1\_CI\_D, RS16\_AI\_CK, S12/P12x\_AI\_D, S4/S2\_AI\_So\_D/(2,3,0).

The coding of the **MI** signals is for further study. As a working solution the following rule is followed:

**<atomic function>\_MI\_<MI signal type>.**

The coding of the **TI** signals is for further study. As a working solution the following rule is followed:

**<layer>\_TI\_<TI signal type: CK or FS>.**

NOTE 1: Most of the adaptation functions have co-directional interfaces (CCITT Recommendation G.703 [7], subclause 1.1.4.1). Contra-directional interfaces (CCITT Recommendation G.703 [7], subclause 1.1.4.3) can be found at the boundaries with "auxiliary" transmission network layers; e.g. RS to DCC.

NOTE 2: Adaptation source functions (functionally) perform the adaptation of a signal from one clock domain to another and/or from one frame phase domain to another. XX\_TI\_CK and XX\_TI\_FS represent those other clock and frame start signals. For example MS1\_TI\_FS, S12\_TI\_CK. Refer also to clause 10.

The coding of the **RI** signals follows the following rule:

**<layer>\_RI\_<RI signal type>.**

### 3.3.5 AU/TU numbering scheme

An STM-1 frame comprises 270 columns (numbered 1 to 270). The first nine columns contain the SOH and an AU-4 pointer with the remaining 261 columns containing the data payload. The payload columns may be addressed by means of a three figure address (K, L, M) where K represents the TUG-3 number, L the TUG-2 number, and M the TU-1 number. Refer to figure 4.

In order to provide a simple and convenient means of determining the total tributary capacity, i.e. the number of lower order tributaries provided, the payload columns are allocated a Time Slot number. The number of time slots per tributary in each frame is determined by the payload configuration.

Time Slots (TSs) are numbered from left to right in the VC-4 as shown in figure 4. For TU-12s, TS1 starts in column 10, TS2 in column 11, and so on until TS63 is in column 72. For TU-2s, TS1 starts in column 10, TS2 in column 11, and ... TS21 in column 30. For TU-3s, TS1 starts in column 4, TS2 in column 5, and TS3 in column 6.

NOTE: The TS number contained in figure 4 should not be interpreted as the tributary port number. Refer to annex D.

**Numbering of AU-4s (VC-4s) in an STM-N signal**

There are N AU-4s (VC-4s) in an STM-N signal; they should be numbered as follows:

AU-4 (VC-4) #1 : indicated by the first AU-4 pointer in the STM-N;

AU-4 (VC-4) #2 : indicated by the second AU-4 pointer in the STM-N;

AU-4 (VC-4) #3 : indicated by the third AU-4 pointer in the STM-N;

:

AU-4 (VC-4) #N : indicated by the Nth AU-4 pointer in the STM-N.



### Numbering of TU-12s (VC-12s) in a VC-4

The VC-4 can comprise three TUG-3s which shall be numbered #1, #2, and #3:

- |          |                                                                                                                                   |
|----------|-----------------------------------------------------------------------------------------------------------------------------------|
| TUG-3 #1 | (corresponding to TUG-3 (A) in ITU-T Recommendation G.709, figure 2.4) is accommodated in columns 4, 7, 10, ..., 259 of the VC-4; |
| TUG-3 #2 | (corresponding to TUG-3 (B) in ITU-T Recommendation G.709, figure 2.4) is accommodated in columns 5, 8, 11, ..., 260 of the VC-4; |
| TUG-3 #3 | (corresponding to TUG-3 (C) in ITU-T Recommendation G.709, figure 2.4) is accommodated in columns 6, 9, 12, ..., 261 of the VC-4. |

Each TUG-3 can comprise seven TUG-2s which shall be numbered #1 to #7 and each TUG-2 can comprise three TU-12s which shall be numbered #1 to #3.

Therefore, any TU-12 can be allocated a number in the form #K, #L, #M, where K designates the TUG-3 number (1 to 3), L designates the TUG-2 number (1 to 7), and M designates the TU-12 number (1 to 3). The location of the columns in the VC-4 occupied by TU-12 (K, L, M) is given by:

$$- \text{Xth column} = 10 + [K-1] + 3 \times [L-1] + 21 \times [M-1] + 63 \times [X-1] \quad \text{for } X = 1 \text{ to } 4.$$

Therefore, TU-12(1,1,1) resides in columns 10, 73, 136, and 199 of the VC-4, and TU-12(3,7,3) resides in columns 72, 135, 198 and 261 of the VC-4. A full listing of the location of the TU-12 columns with the VC-4 frame is given in annex E.

### Numbering of TU-2s (VC-2s) in a VC-4

Similarly, any TU-2 can be allocated a three figure address in the form #K, #L, #M, where K designates the TUG-3 number (1 to 3), L designates the TUG-2 number (1 to 7), and M is always 0. The location of the columns in the VC-4 occupied by TU-2 (K, L, 0) is given by:

$$- \text{Xth column} = 10 + [K-1] + 3 \times [L-1] + 21 \times [X-1] \quad \text{for } X = 1 \text{ to } 12.$$

Therefore, TU-2(1,1,0) resides in columns 10, 31, 52, 73, 94, 115, 136, 157, 178, 199, 220 and 241 of the VC-4, and TU-2(3,7,0) resides in columns 30, 51, 72, 93, 114, 135, 156, 177, 198, 219, 240 and 261 of the VC-4. A full listing of the location of the TU-2 columns with the VC-4 frame is given in annex E.

### Numbering of TU-3s (VC-3s) in a VC-4

Similarly, any TU-3 can be allocated a three figure address in the form #K, #L, #M, where K designates the TUG-3 number (1 to 3), L and M are always 0. The location of the columns in the VC-4 occupied by TU-3 (K,0,0) is given by the formula:

$$- \text{Xth column} = 4 + [K-1] + 3 \times [X-1] \quad \text{for } X = 1 \text{ to } 86.$$

Therefore, TU-3(1,0,0) resides in columns 4, 7, 10, ..., 259 of the VC-4, and TU-3(3,0,0) resides in columns 6, 9, 12, ..., 261 of the VC-4.

## 3.3.6 Reference points numbering scheme

The Access Point (AP) number is used to uniquely identify an AP.

The Termination Connection Point (TCP) number is the AP number associated with the trail termination function.

The Connection Point (CP) number is the AP number associated with the connected adaptation function, extended with the multiplex number, e.g. the AU or TU number.

## 3.3.7 Tributary port numbering scheme

The tributary port numbering is for further study.

### 3.3.8 PU numbering scheme

#### Numbering of PU12 (2 Mbit/s) signals in an 8 448 kbit/s signal

According to CCITT Recommendation G.742 [9], the 8 448 kbit/s signal comprises four PU12 (2 Mbit/s) signals, which shall be numbered #1, #2, #3, and #4 (figure 5):

- PU12 #1 is accommodated in column 1 rows 4 to 212 of the 8 448 kbit/s;
- PU12 #2 is accommodated in column 2 rows 4 to 212 of the 8 448 kbit/s;
- PU12 #3 is accommodated in column 3 rows 4 to 212 of the 8 448 kbit/s;
- PU12 #4 is accommodated in column 4 rows 4 to 212 of the 8 448 kbit/s.

#### Numbering of PU22 (8 Mbit/s) signals in an 34 368 kbit/s signal

According to CCITT Recommendation G.751 [10], the 34 368 kbit/s signal comprises four PU22 (8 Mbit/s) signals, which shall be numbered #1, #2, #3, and #4 (figure 5):

- PU22 #1 is accommodated in column 1 rows 4 to 384 of the 34 368 kbit/s;
- PU22 #2 is accommodated in column 2 rows 4 to 384 of the 34 368 kbit/s;
- PU22 #3 is accommodated in column 3 rows 4 to 384 of the 34 368 kbit/s;
- PU22 #4 is accommodated in column 4 rows 4 to 384 of the 34 368 kbit/s.

#### Numbering of PU31 (34 Mbit/s) signals in an 139 264 kbit/s signal

According to CCITT Recommendation G.751 [10], the 139 264 kbit/s signal comprises four PU31 (34 Mbit/s) signals, which shall be numbered #1, #2, #3, and #4 (figure 5):

- PU31 #1 is accommodated in column 1 rows 5 to 732 of the 139 264 kbit/s;
- PU31 #2 is accommodated in column 2 rows 5 to 732 of the 139 264 kbit/s;
- PU31 #3 is accommodated in column 3 rows 5 to 732 of the 139 264 kbit/s;
- PU31 #4 is accommodated in column 4 rows 5 to 732 of the 139 264 kbit/s.

NOTE: In contrast to SDH, PDH multiplexed signals are bit rather than byte interleaved.

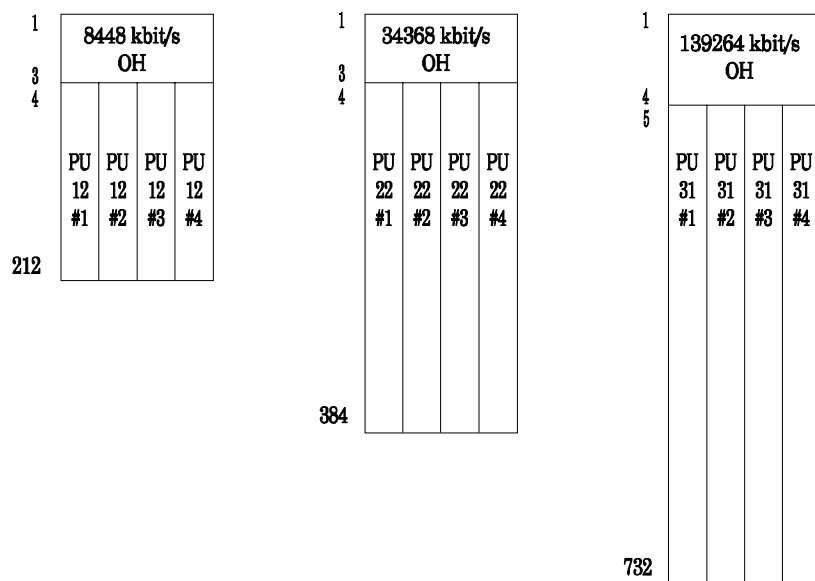

Figure 5: PU12, PU22, and PU31 numbering scheme



### 3.3.9 Supervision variables numbering scheme

The supervision variables "yZZZ" are defined as:

y	defect:	y = d
	fault cause (i.e. correlated defect):	y = c
	failure:	y = f
	consequent action request:	y = a
	performance parameter:	y = p
	anomaly:	y = n
ZZZ	kind of defect, fault cause, failure, consequent action, performance parameter or command	

dZZZ, cZZZ, and fZZZ represent Boolean variables with states TRUE or FALSE. pZZZ represents an integer variable. aZZZ, except aREI, represent a Boolean variable; aREI represents an integer variable.

## 3.4 Symbols and diagrammatic conventions

The diagrammatic conventions and nomenclature used in the present document for adaptation, termination and connection functions (used to describe the atomic functions) are shown in figure 6. As an example of the use of this nomenclature, figure 7 shows an example of an unidirectional VC-4 path in a SDH network.

Adaptation functions from Server layer Y to Client layer Z

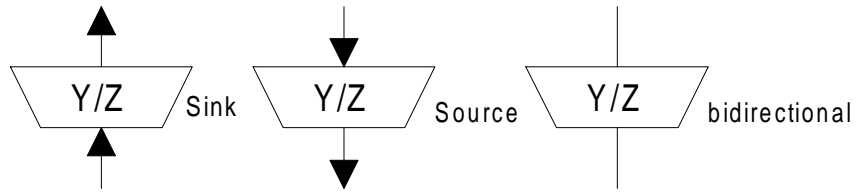

Trail Termination functions in layer Y

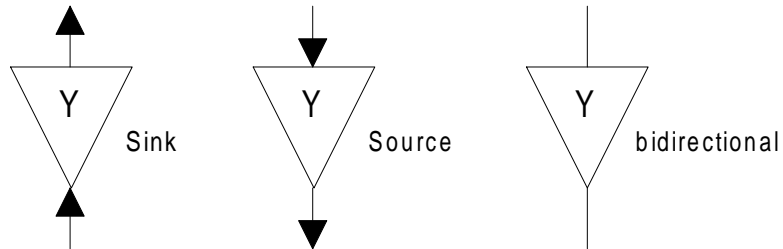

Connection functions in layer Y

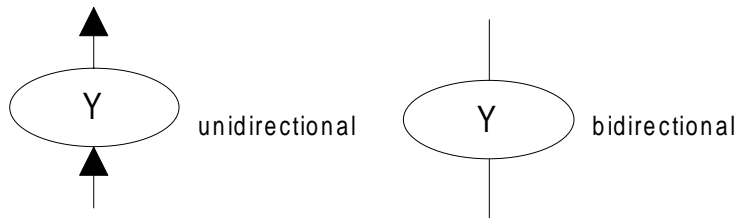

Trail Termination function in layer Y and Adaptation function to layer Z

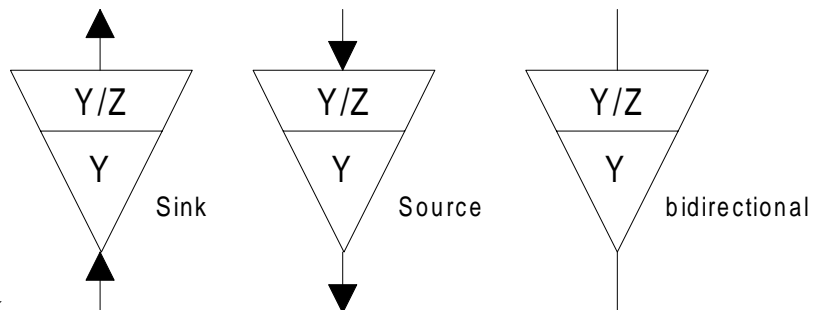

SDHnetwork.

NOTE: If the above symbols are used for generic figures, i.e. not for specific layers, the layer references Y and Z may be omitted. Alternatively, the references may be to the type of function or layer, e.g. supervision, protection.

Figure 6: Symbols and diagrammatic conventions

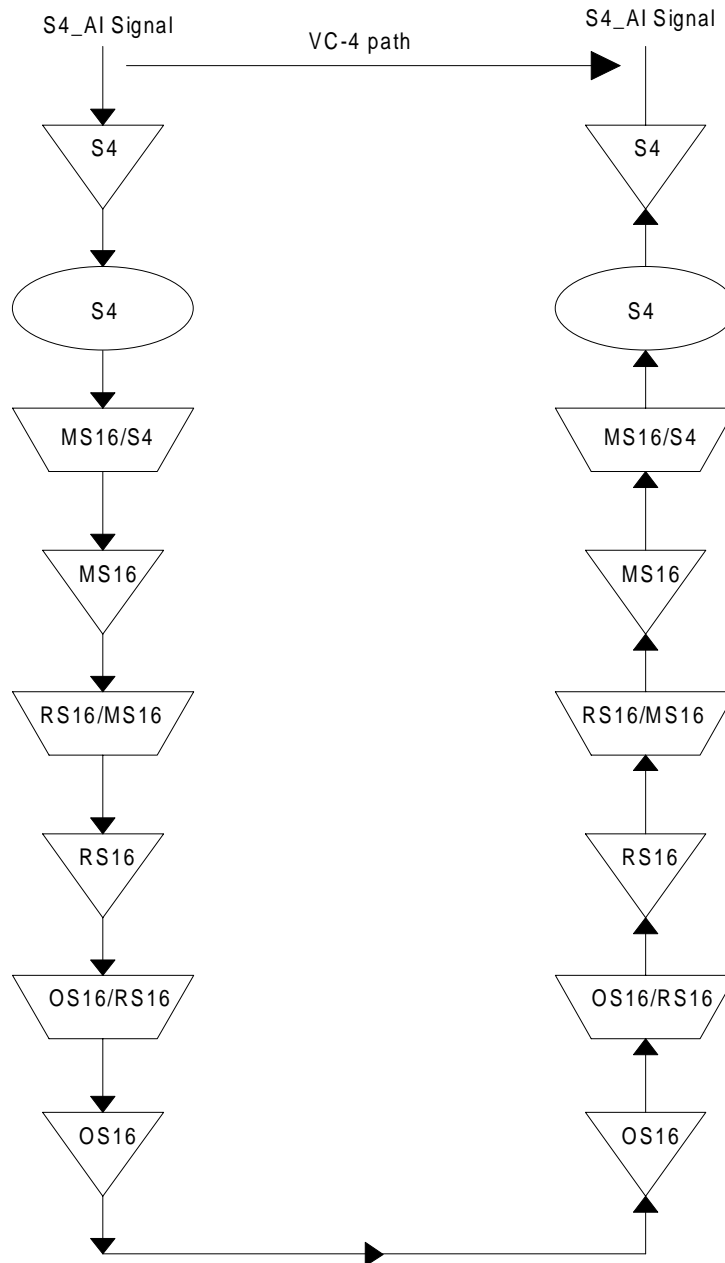

Figure 7: Example of a VC-4 path in an SDH network

## 4 Introduction

Digital transmission systems can be broadly described as a collection of multiplexing, framing, transport, routing, timing and protection processes. The details of each process and the way in which they are interconnected is described by a digital transmission hierarchy. Each of these processes can be decomposed into a collection of Atomic (Indivisible) functions. The digital transmission hierarchy itself can be decomposed into a number of layers, each of which contain atomic functions. Interfaces between layers are also defined by atomic functions. Each layer and each function have a set of characteristics which are defined within the present document. Since equipment which is compliant with the present document is describable as an interconnection of functions defined within the present document, compatibility between equipment of different vendors is assured.

The description methodology also imposes a discipline on manufacturers and purchasers of digital transmission equipment. Complicated networking and transportation processes are decomposed into a combination of much simpler functions thereby assisting system design.

The method of functional decomposition described in the following subclauses and the symbols and unique names which are used to describe the atomic functions combine to form a short-hand diagrammatic notation which can be used to specify the functionality of an equipment or a network. It is intended that this short-hand notation should simplify technical descriptions and tenders since reference to the present document will give engineers a common understanding of the symbols and names used.

## 4.1 Functional modelling rationale

A limited set of atomic functions has been derived by decomposing the European digital transmission hierarchy to form the library contained within the present document. The contents of this library are consistent with the definitions of functions contained in ITU-T Recommendation G.783 [12]. In order to be compliant with the present document, equipment which contains functionality defined within the present document should only use the functions as explicitly defined. As technology evolves, new network elements requiring additional atomic functions may be developed. These additional atomic functions, which are not contained within the present document, may be used. The use and definition of such additional functions should be submitted for standardization and inclusion within the present document at the earliest opportunity.

Three types of atomic function are required to describe a transmission network. According to ITU-T Recommendation G.803 [6], these are:

- the connection function;
- the adaptation function;
- the termination function.

Each of these functions can be unidirectional or bi-directional. The direction of transmission through an unidirectional function is identified by defining it as a sink or a source function.

### 4.1.1 Description of network elements - equipment functional specification

A Network Element (NE) (equipment) is described by its Equipment Functional Specification (EFS) that accommodates a list of applicable atomic functions and their interconnection scheme. A network element can be most easily and concisely specified as a collection of atomic and/or compound functions by representing these functions in diagrammatic form as stated in the present document.

The present document specifies the components and the methodology that should be used to specify SDH equipment; it does not describe an individual SDH equipment as such.

### 4.1.2 Implementation independence

The atomic functions and their interconnection in an EFS, describe the functionality as it can be observed from the inputs and outputs of the NE. The internal structure of the implementation of this functionality (equipment design) need not be identical to the structure of the functional model, as long as all the details of the externally observable behaviour comply with the EFS.

NOTE: One exception to this implementation independence rule is recognized. Refer to subclause 5.2.1.

### 4.1.3 Universal representation for management

Implementation independent descriptions of network functions, such as those given in the present document, form the basis of a generic information model for digital transmission equipment (ETS 300 304 [3]). This model will be applicable to any equipment which is compliant with the present document since network control and monitoring are related to the functions contained in the library of the present document, and from which subsets of functions are drawn to describe compliant equipment. Consequently, implementation and manufacturer information is reduced to a minimum. Some manufacturer specific information is required for repair and maintenance purposes.

## 4.2 The underlying principles of functional modelling

### 4.2.1 The client-server relationship

ITU-T Recommendation G.803 [6] defines a collection of layers which model the digital transmission hierarchy. Each layer is related to the adjacent layer in one of two ways. It either serves the adjacent layer or is served by the adjacent layer. When the layer serves the adjacent layer it is called a server layer and when it is served by the adjacent layer it is called a client layer. Thus, a client / server relationship is established between the layers which describe the digital transmission hierarchy. This relationship is recursive. ITU-T Recommendation G.803 [6] describes the generic properties of the layers which describe the digital transmission hierarchy and the functions from which such networks are constructed. The present document gives specific definitions for the network functions which form each layer of the European digital transmission hierarchy.

### 4.2.2 Atomic functions and compound functions

The main unit of equipment specification is the atomic function, which may be interconnected as discussed in clause 6. Groups of atomic functions within a library of atomic functions may be combined in accordance with the combination rules, stated in the present document, to form compound functions. Functions can also be combined across layer boundaries to form more complicated major compound functions. A number of (major) compound functions which are fundamental to the European digital transmission hierarchy are defined in the present document. These definitions are consistent with the definitions contained in ITU-T Recommendation G.783 [12] although in some cases the definitions given in the present document will contain supplementary points of detail. Equipment which is compliant with the present document can be specified by using any valid combination of these compound functions and the atomic functions defined in the present document. The mechanism by which atomic and/or compound functions are combined by binding at compatible connection and access points is defined in clause 6.

### 4.2.3 Network functions included in specific equipment

The grouping of atomic and/or compound functions, drawn from the libraries of these functions contained within the present document, is restricted only by the combination rules given in clause 6. There is therefore no restriction on the functions which can be included in a specific equipment. Furthermore, it is possible to specify equipment which complies with the present document and which can be configured in a number of ways to carry out different network functions.

For example: More than one adaptation function, of the same or of a different type, can be "present" in a Network Element (NE) and connected to a single termination function. For such a case, a subset of the adaptation functions may be "active" (providing service) while the others are "in-active". The signals applied to the "in-active" group of adaptation source functions are not forwarded to the termination source function. This configuration can be modified over time.

### 4.2.4 The functional model and the information model

The **Functional Model** of an equipment describes the way in which the equipment accepts, processes and forwards information contained in a signal. Thus, not only are the internal processes of the equipment specified but the internal and external interfaces are also specified. The functional model also specifies the performance criteria which shall be met by each process, and the actions which shall be taken when these performance criteria are not met. The performance of a process or interface is determined by the number and nature of the anomalies which occur within the process.

The **Information Model** describes an equipment from the management viewpoint as a collection of Managed Objects (MOs) which can be manipulated by a management system. These MOs are instances of the MO classes defined in ETS 300 304 [3]. These MOs, and their attributes, are expressed in a standard notation defined for this purpose (refer to CCITT Recommendation X.721 [21]). The definition of each MO class is thus derived from a specific part of the functional model. It cannot be assumed that a one-to-one relationship exists between each function and each MO, neither should it be assumed that the functional model data is always displayed unchanged.

The relationship between functions in the functional model of an equipment, and the managed objects which represent them in the Information model is demonstrated by the following examples. Interconnections between functions formed by binding compatible connection points appear in the information model as a relationship between the corresponding MOs. As a second example, when a function declares a failure (refer to subclause 6.2) it appears in the information model as a notification, which informs the manager of the functional model event. The management system can select the notifications it wishes to receive, so it cannot be assumed that an event in the equipment is always notified to the management system.

This multi-part EN and ETS 300 304 [3] are, therefore, closely associated. It is intended that the definition of the attributes for a MO contained within the information model corresponds to the functional definition of the NE concerned.

## 5 Network layering principles

### 5.1 Transmission layers

The transport network can be described by a set of network layers. Figures 8 and 9 depict the server/client relationships of some of the SDH and PDH layers. Interconnection of SDH and PDH is possible via equivalent connection points; e.g. X4 CP (140 Mbit/s), P12x CP (see note) (2 Mbit/s).

NOTE: X, P are all layers: e.g. X4 is a layer which transports a 139 264 kbit/s signal, P4e is the path layer of a 139 264 kbit/s signal made up of 4 x 34 368 kbit/s signals, and P0\_31c is the layer which transports a 1 984 kbit/s signal.

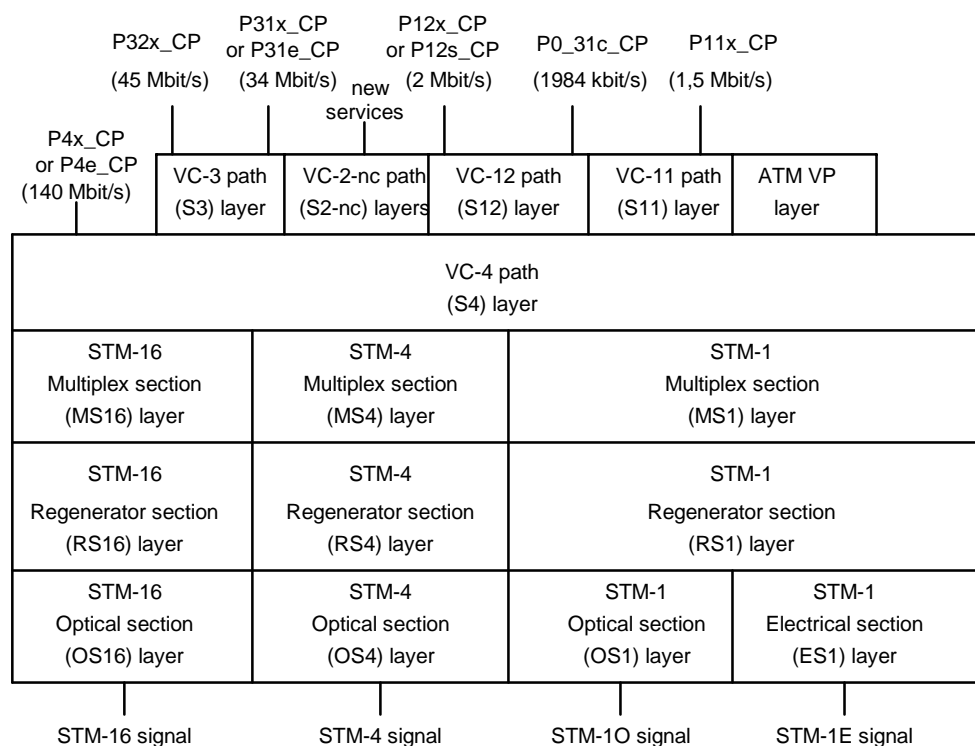

**Figure 8: Example of SDH transmission layers and interface signals**

Almost every layer has a server / client relationship with auxiliary channel layers. This is not shown in the figures. Examples are Order Wire (OW), User channels (USR) and National Use (NU) channels. Their electrical interface can be, for the case of a 64 kbit/s auxiliary channel, the E0 layer or a similar data communication layer can be V.11. Other examples are the Data Communications Channels (DCCs) in the regenerator and multiplex section layers.

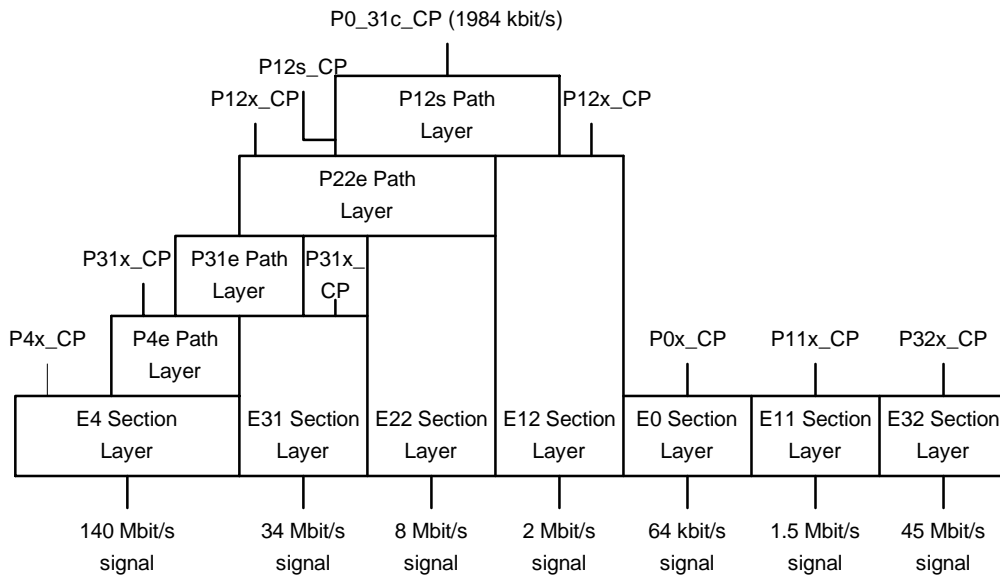

**Figure 9: Example of PDH transmission layers and interface signals**

Not shown, but addressed in this part of the present document, is the synchronization distribution layer which describes the synchronization function of SDH equipment. Management, power supply and station alarm interfaces are for further study.

## 5.2 Atomic functions

Each layer is described by a set of atomic functions (figure 10) a connection function, a trail termination function and one or more server layer to client layer adaptation functions.

An NE (i.e. transmission equipment) is described by means of these functions in an Equipment Functional Specification (EFS). If a layer is present in a network element any of the following atomic function groups might be present:

- 1) its connection function (cross-connecting only);
- 2) its connection function and its trail termination function (cross-connecting only with non-intrusive monitoring);
- 3) its trail termination and one or more of its adaptation functions. Its connection function may or may not be present. (trail is terminated and the payload is passed to the client layers).

Similarly, it is possible to describe a (sub-)network by means of those symbols.

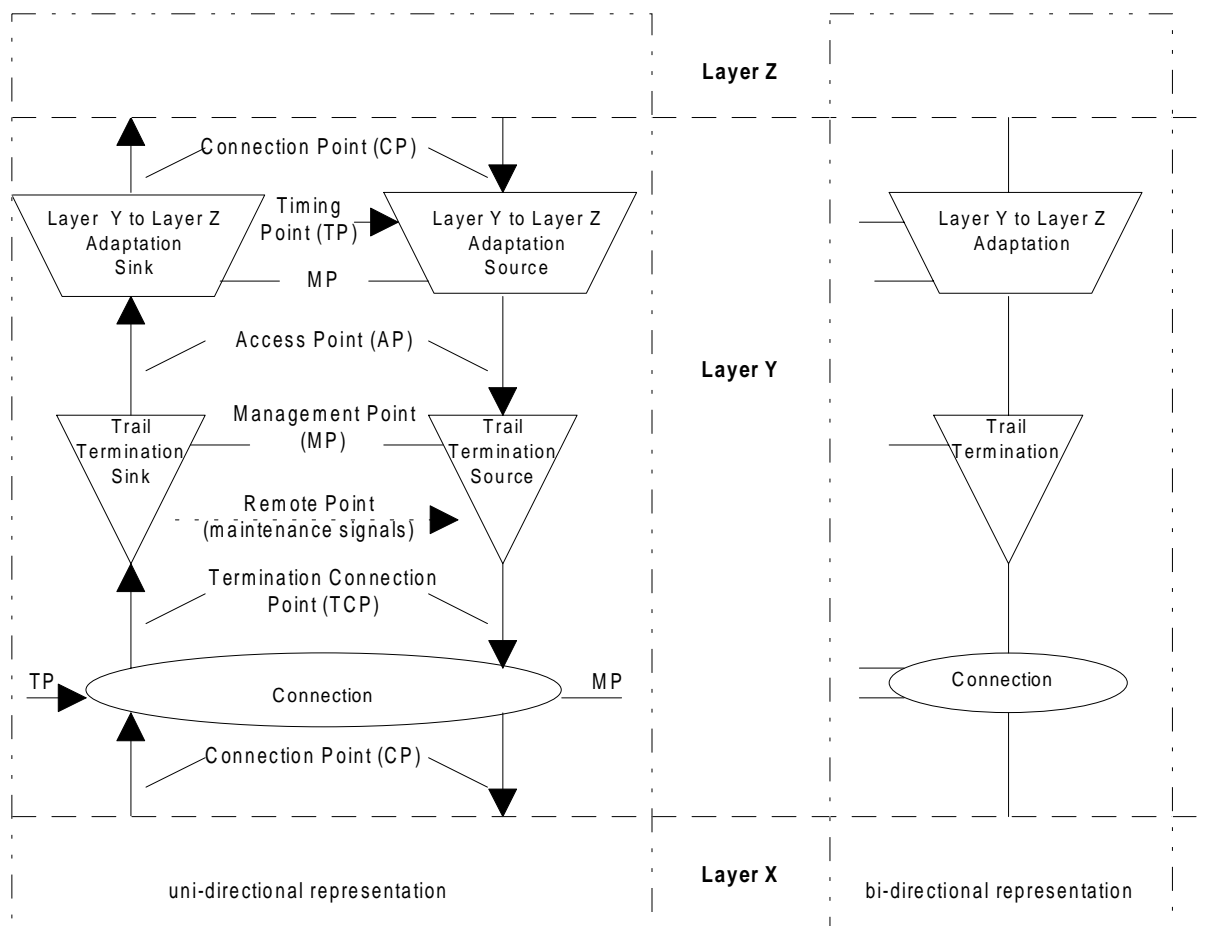

Figure 10: Atomic functions in a layer

### 5.2.1 Connection function

The connection function provides flexibility within a layer. It may be used by the network operator to provide routing, grooming, protection and restoration.

**NOTE:** The connection function's flexibility process is modelled as a "space switch". In equipment the switch matrix type may be either a "space switch" or a combination of "space and time switches". If a time switch is involved the adaptation source functionality shall be located at the input of the switch matrix (connection function) rather than at the output (as in the functional model).

The location of the adaptation source functionality (i.e. Elastic Store and Pointer Generator) with respect to the connection functionality (i.e. switch matrix) is observable at the STM-N interface when the matrix connection is changed (e.g. due to SNC protection switch). A pointer with "enabled NDF" is generated when the adaptation source functionality is located at the output of the connection functionality. A pointer without "enabled NDF" is generated when the adaptation source functionality is located at the input of the connection functionality.



## 5.2.2 Trail termination function

The Trail Termination function performs the signal integrity supervision of the layer. In the source direction it generates and adds some or all of the following:

- error detection code (e.g. Bit Interleaved Parity (BIP), Cyclic Redundancy Check (CRC));
- trail trace identifier (i.e. source address).

It conveys back the following remote information:

- remote error indicator signal (e.g. FEBE, E-bit), containing the number of detected error detection code violations in the received signal;
- remote defect indicator signal (e.g. FERF, A-bit), representing the defect status of the received signal.

In the sink direction, it monitors for some or all of the following:

- bit errors;
- (mis)connection;
- near-end performance;
- far-end performance;
- server signal fail (i.e. Alarm Indication Signal (AIS) instead of data);
- signal loss (disconnection, idle signal, unequipped signal).

**NOTE:** These functionalities are reduced in the physical section layer termination functions, which can only monitor the signal loss. The physical section termination source function performs in addition logical / optical, respectively logical / electrical conversion. The physical section termination sink function performs in addition optical / logical, respectively electrical / logical conversion.

Bit errors are detectable via line code violations, parity violations or CRC violations; i.e. error detection code violations.

To monitor the provisioning of flexibility within an SDH network, Access Points (APs) will be identified (named/numbered). That identifier is inserted in the signal, by the Trail Termination source function, in the Trail Trace Identifier. (TTI) The Trail Termination sink function checks the received name / number with the expected one (provisioned by the network manager).

To enable single ended maintenance, the defect status and number of error detection code violations detected at the sink trail termination are conveyed back to the source trail termination; the defect status via the Remote Defect Indicator (RDI) signal and the number of error detection code violations via the Remote Error Indicator (REI) signal. The RDI and REI signals are part of the trail overhead.

Degradation of the signal results in the detection of anomalies and defects. As a consequent action of the detection of defects, the signal is replaced by the all-ONEs (AIS) signal and RDI is inserted in the return direction. The defects are reported to the fault management process.

The number of near-end block errors, detected by means of error detection code violation monitoring, per second is counted. The number of far-end block errors, conveyed back via REI, per second is counted. A second is indicated as a near-end defect second in cases where a signal fail condition was detected in that second. A second is indicated as a far-end defect second in cases where a RDI defect was detected in that second.

Errored Seconds (ES), Severely Errored Seconds (SES) and Unavailable Seconds (UAS) indications are derived from the one-second error counts and the defect seconds. They are reported to the performance management process.

Refer to the anomaly process description (clause 8) for detailed specifications.

### 5.2.3 Adaptation function

An adaptation function represents the conversion process between a server and a client layer. One or more of the following processes may be present in an adaptation function:

- scrambling / descrambling;
- encoding / decoding;
- alignment (framing, pointer interpretation, FAS/PTR generation);
- bit rate adaptation;
- frequency justification;
- multiplexing / demultiplexing;
- timing recovery;
- smoothing;
- payload identification.

The **scrambling** process alters digital data in a pre-defined way to ensure the resulting bit stream has a sufficient density of 0 → 1 and 1 → 0 transitions to allow bit clock recovery from it. The **descrambling** process recovers the original digital data from the scrambled bitstream.

The **encoding/decoding** process adapts a digital data stream to the characteristics of the physical medium over which it is meant to be transported. The **decoding** process recovers the original digital data from the medium specific form in which it is received.

The **alignment** process locates the first bit / byte of the framed signal (Frame Start (FS)) by means of a search for the Frame Alignment Signal (FAS) or the interpretation of the Pointer (PTR). If the FAS can not be found or the PTR is corrupted for a specific period, an alignment defect is detected (LOF, LOP). The alignment defect may be the result of the reception of the all-ONES (AIS) signal. If so, the AIS defect is detected also. The defects are reported to the fault management layer / process.

The **bit-rate adaptation** process accepts input information at a certain bit rate and outputs that same information at a different bit rate. In the source direction, this process creates gaps in which other adaptation functions can add their signals. An example is the S12/P12s\_A\_So function; the 2 Mbit/s signal input to this function is output at a higher bit rate. The created gaps will be filled with the VC-12 POH.

The **frequency justification** process accepts an input information at a certain frequency and outputs that same information either at the same or at a different frequency. In the source direction, in order to accommodate any frequency (and/or phase) differences between input and output signals, this process may write data into a specific "justification" bit / byte in the outgoing frame structure when the elastic store (buffer) is going to overflow. It will skip data writing when the elastic store is going to underflow. Examples are the S4/S12\_A\_So and P4e/P31e\_A\_So functions.

NOTE: The commonly used terms mapping and demapping are covered by bit-rate adaptation and frequency justification processes.

The **multiplexing/demultiplexing** process is modelled by means of multiple adaptation functions, connected to one AP (subclause 6.3). The information applied by the connected adaptation source functions ends up in pre-allocated time slots of the resulting time division multiplexed signal. Adaptation sink functions extract their associated adapted information from the common access point. Adaptation source / sink functions receive the necessary information allowing determination of correct write / read timing.

The **timing recovery** process extracts a clock signal, the "recovered clock", from the incoming data signal. The timing recovery process is performed in the adaptation sink function in the physical section layer; e.g. in OS16/RS16\_A\_Sk.

The **smoothing** process filters the phase step of "gapped input signals". The smoothing process is performed in the adaptation sink functions; e.g. in Sm/Xm\_A\_Sk, Pn/Pm\_A\_Sk.

Many layers are able to transport a variety of client signals applied to the layer via different adaptation functions. To monitor the provisioning process the source Adaptation inserts the appropriate code in the Trail Signal Label (TSL). The sink adaptation will check the **composition of the payload** comparing the received TSL number with its own one.

## 5.3 Reference points

Reference points (see note) between atomic functions are called Connection Points (CPs), Access Points (APs), Timing Points (TPs) and Management Points (MPs) (see figure 10). A subset of the connection points are the Termination Connection Points (TCPs).

NOTE: ITU-T Recommendation M.3010 defines reference points and interfaces as follows:

**Reference points:** reference points define service boundaries between management function blocks. The purpose of reference points is to identify the information passing between function blocks.

**Interfaces:** TMN standard interfaces are defined corresponding to the reference points. They are applied at these reference points when external physical connections to them are required.

The information passing a CP is called Characteristic Information (CI), the information passing an AP is called Adapted Information (AI), the information passing a MP is called Management Information (MI), and the information passing a TP is called Timing Information (TI). The CI, AI, TI, and MI is represented by a number of signals. Refer to subclause 3.3.4.

## 5.4 Transmission sub-layers

A transmission (transport) layer may be decomposed into sub-layers to support administrative domains or protection within the layer:

- trail protection is modelled by expansion of the trail termination function adding the protection adaptation function, the protection connection function and the protection trail termination function;
- tandem connection monitoring is modelled by the expansion of the (termination) connection point. Exact modelling requires further study.

## 6 Combination rules

### 6.1 General

In general, any functions which share the same characteristic or adapted information may be combined.

#### 6.1.1 Binding at connection points

The connection point input (output) of an adaptation function may be bound to the connection point output (input) of either a connection function or an adaptation function, as shown in figure 11.

EXAMPLE: An S12\_CP of an S12\_C function may be connected to an S12\_CP of an S4/S12\_A function.

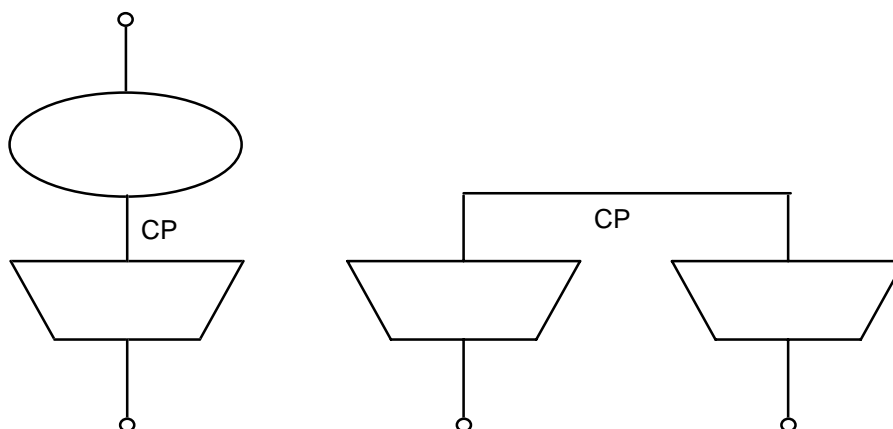

Figure 11: Binding of connection points (CP-CP binding)

#### 6.1.2 Binding at (termination) connection points

The termination connection point output (input) of a trail termination function may be bound to the connection point input (output) of either an adaptation function or a connection function or the termination connection point input (output) of a trail termination function, as shown in figure 12.

EXAMPLE: An S12\_TCP of an S12\_TT function may be connected to an S12\_CP of an S12\_C function.

NOTE: Once bound the CP and TCP are referred to as a termination connection point.

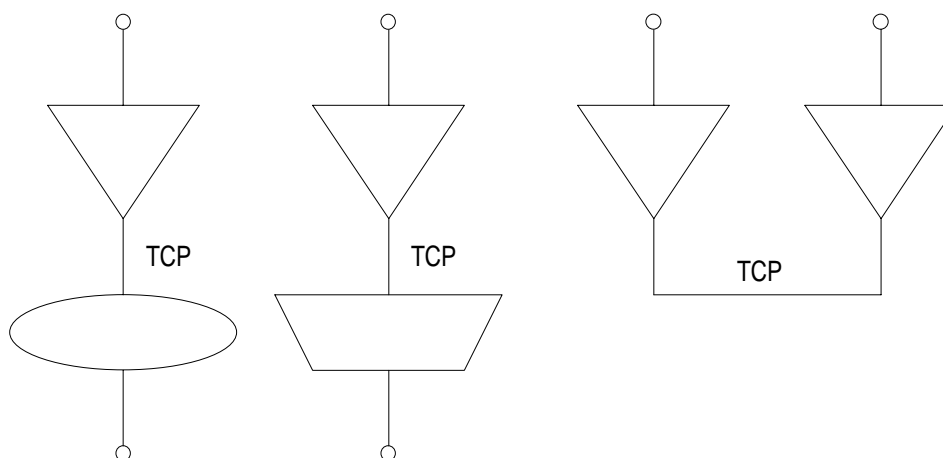

Figure 12: Binding involving a termination connection point (TCP-CP and TCP-TCP binding)

### 6.1.3 Binding at APs

The AP input (output) of a trail termination function may be bound to the AP output (input) of an adaptation function as shown in figure 13.

EXAMPLE: An S4\_AP of an S4/S12\_A function may be connected to an S4\_AP of an S4\_TT function.

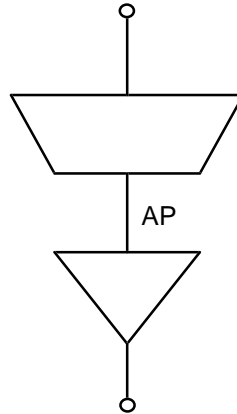

Figure 13: Binding of Access Points (AP-AP binding)

### 6.1.4 Alternative binding representations

The binding at reference points can continue, according to the above rules, and create a path such as the one shown in figure 14.

NOTE: The binding at reference points may also be represented as illustrated in figure 14. In Equipment Functional Specifications (EFSs), the explicit reference to the reference points is not required if the atomic functions are named. In such a case, the names of the reference points are obvious.

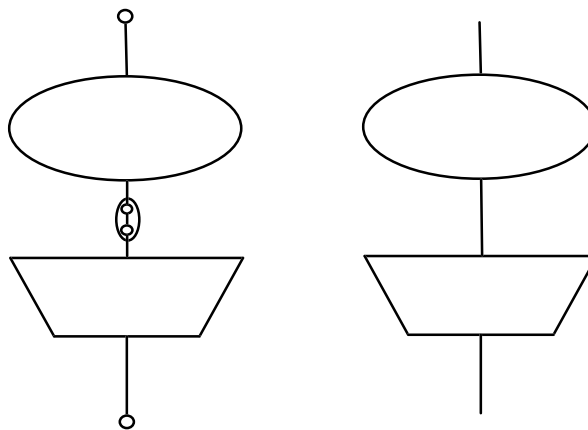

Figure 14: Alternative representations

## 6.2 Directionality

One source atomic function and one sink atomic function, with their associated RDI/REI maintenance channels connected may be associated as a bi-directional pair (when a function is referred to without the directionality qualifier it can be taken to be bi-directional). Bi-directional servers may support bi-directional or unidirectional clients but unidirectional servers may only support unidirectional clients.

## 6.3 Compound functions

Combinations of atomic functions in one layer may be identified by a special symbol, a compound function. Two examples are shown in figures 15 and 16.

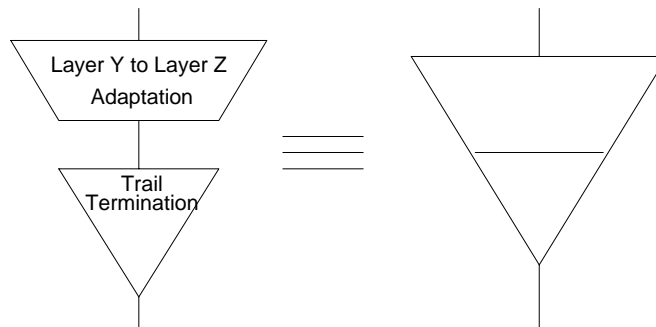

**Figure 15: Compound termination / adaptation function**

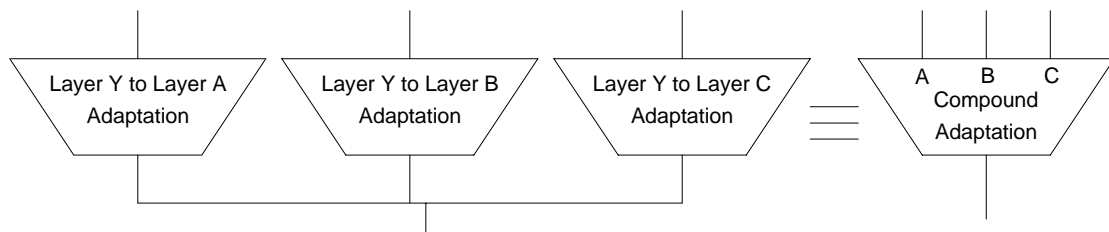

**Figure 16: Compound adaptation function**

## 6.4 Major compound functions

Combinations of atomic functions in more than one layer may be identified by a special symbol, a major compound function. An example is shown in figure 17.

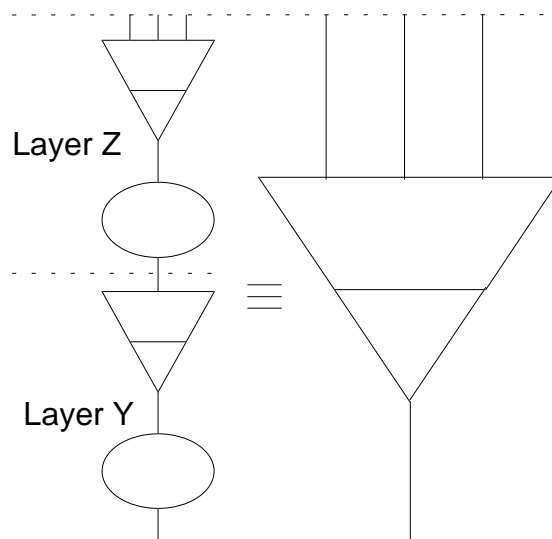
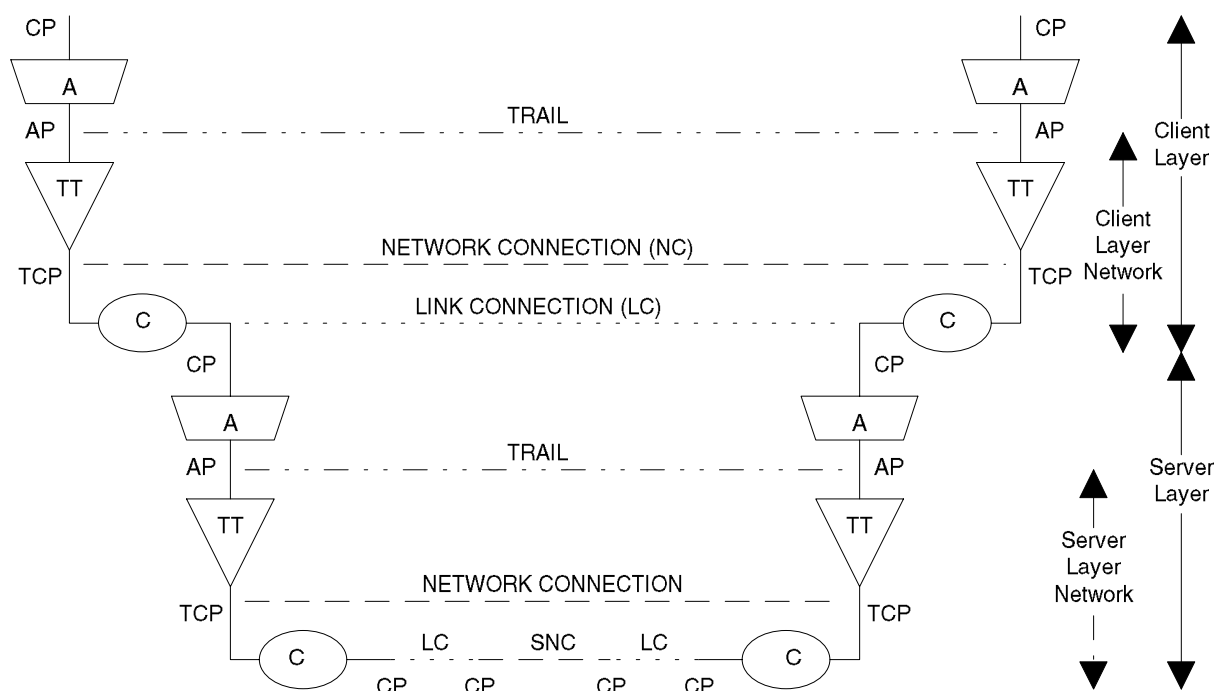

**Figure 17: Major compound function**

## 6.5 Trail, (sub)network connections, link connections, matrix connections, and tandem connections

An example of a network fragment illustrating the definition of a trail, a network connection, a link connection, and a sub-network connection is shown in figure 18.

The modelling of tandem connections is for further study.



**Figure 18: Network fragment illustrating trail, (sub)network connections and link connections**

The relationship between trails, (sub-)network connections, link connections, atomic functions, and reference points can be described by means of the "production rules" of a network. Refer to annex C.

## 6.6 Matrix connections

Connection functions are defined as matrices with explicitly defined connectivity available between sets of TCPs and CPs, and CPs and CPs. These can be described as an **n-port** ( $n \geq 1$ ) matrix, the connectivity of which is described by means of a table. A single physical matrix may be configured to provide separate logical connection functions in more than one layer.

Multiple physical matrices may be configured to provide one logical connection function. This may introduce limited connectivity. The connectivity of this function may be represented in one table. Alternatively, the connectivity may be represented by means of a number of interconnected matrices each with their own table.

The assignment of incoming signals to outgoing signals (e.g. VC-ns) at (T)CPs is defined as the "connection pattern" which can be described by any unidirectional connection matrix  $CM((T)CP_i, (T)CP_j)$ , where  $(T)CP_i$  identifies input  $(T)CP$  number  $i$  and  $(T)CP_j$  identifies output  $(T)CP$  number  $j$ . There may be a limitation in the flexibility of the connection matrix which can be exercised; i.e. the number of fields  $((T)CP_i, (T)CP_j)$  in the  $CM$  representing valid input / output combinations in a particular implementation could be restricted. This is illustrated in subclauses 6.6.1 to 6.6.4.

### 6.6.1 1-port

The set of input and output ports is not divided into subsets. This CM allows interconnectivity as given in table 1.

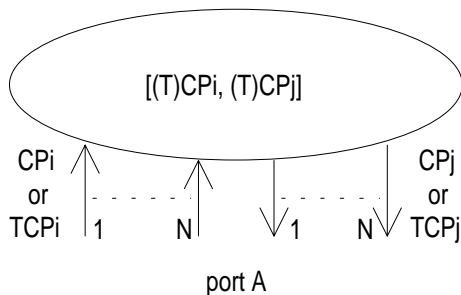

**Figure 19: Example of connection matrix for 1-port**

**Table 1: Example of connection matrix for 1-port**

		<b>INPUT</b>
		$A_j$
<b>OUTPUT</b>	$A_j$	X

- X: Indicates (T)CP<sub>i</sub> - (T)CP<sub>j</sub> connection possible for any i and j.
- i=j: Indicates (T)CP<sub>i</sub> - (T)CP<sub>j</sub> connection possible only in the case that i=j (e.g. loopback).
- : Indicates no connection possible.

### 6.6.2 2-port

The set of input and output ports is divided into two subsets, each containing both input and output ports.

EXAMPLE: CPs at the line side and TCPs at the tributary side.

Table 2 gives an example of a possible interconnectivity limitation of a 2-port matrix.

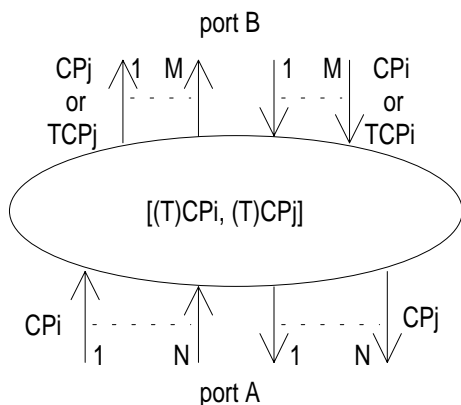

**Figure 20: Example of connection matrix for 2-port**



**Table 2: Example of connection matrix for 2-port**

		INPUT	
		A <sub>i</sub>	B <sub>i</sub>
OUTPUT	A <sub>j</sub>	i=j	X
	B <sub>j</sub>	X	i=j

X: Indicates (T)CP<sub>i</sub> - (T)CP<sub>j</sub> connection possible for any i and j.  
 i=j: Indicates (T)CP<sub>i</sub> - (T)CP<sub>j</sub> connection possible only in the case that i=j (e.g. loopback).  
 - : Indicates no connection possible.

### 6.6.3 3-port

The set of input and output ports is divided into three subsets, each containing both input and output ports.

EXAMPLE: CPs at the West line side, CPs at the East line side and TCPs at the tributary drop side.

Table 3 gives an example of a possible interconnectivity limitation of a 3-port matrix.

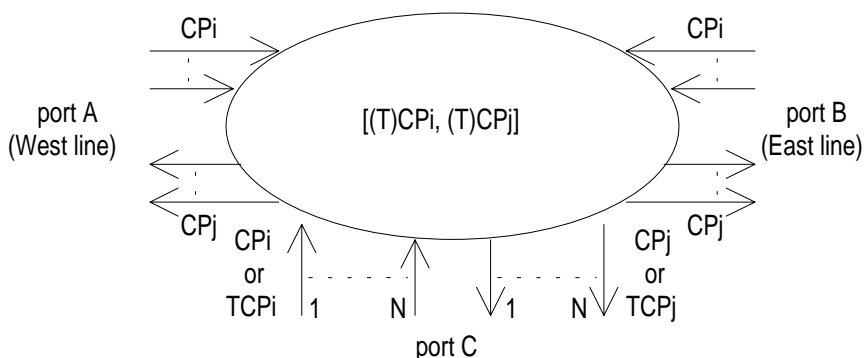

**Figure 21: Example of connection matrix for 3-port**

**Table 3: Example of connection matrix for 3-port**

		INPUT		
		A <sub>i</sub>	B <sub>i</sub>	C <sub>i</sub>
OUTPUT	A <sub>j</sub>	i=j	X	X
	B <sub>j</sub>	X	i=j	X
	C <sub>j</sub>	X	X	i=j

X: Indicates (T)CP<sub>i</sub> - (T)CP<sub>j</sub> connection possible for any i and j.  
 i=j: Indicates (T)CP<sub>i</sub> - (T)CP<sub>j</sub> connection possible only in the case that i=j (e.g. loopback).  
 - : Indicates no connection possible.

## 6.6.4 4-port

The set of input and output ports is divided into four subsets, each containing both input and output ports.

**EXAMPLE:** CPs at the West line side, CPs at the East line side, TCPs at the West tributary drop side, and TCPs at the East tributary drop side.

Table 4 gives an example of a possible interconnectivity limitation of a 4-port matrix.

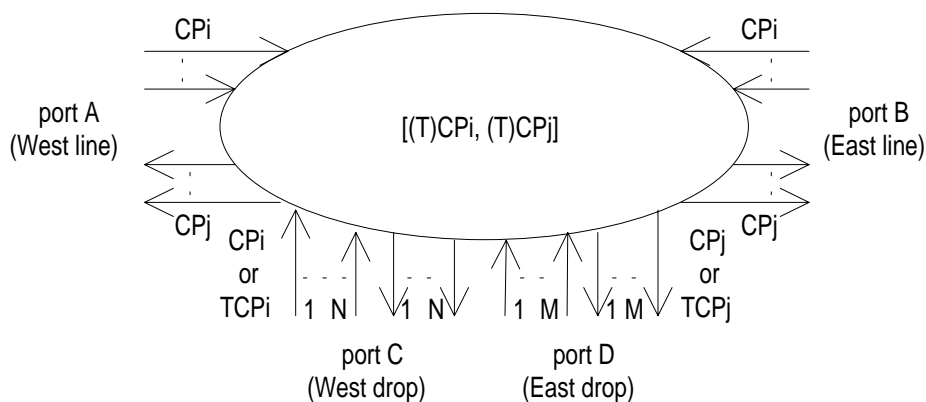

**Figure 22: Example of connection matrix for 4-port**

**Table 4: Example of connection matrix for 4-port**

		INPUT			
		$A_j$	$B_j$	$C_j$	$D_j$
OUTPUT	$A_j$	-	$i=j$	X	-
	$B_j$	$i=j$	-	-	X
	$C_j$	X	-	-	-
	$D_j$	-	X	-	-

X: Indicates (T)CP<sub>i</sub> - (T)CP<sub>j</sub> connection possible for any i and j.  
 i=j: Indicates (T)CP<sub>i</sub> - (T)CP<sub>j</sub> connection possible only in the case that i=j (e.g. no time slot Interchange).  
 -: Indicates no connection possible.

## 7 Maintenance signals and processes

This clause describes processes and signals designed to aid the maintenance of trails.

### 7.1 Trail Trace Identifier (TTI)

The TTI is used to indicate trail set-up completion and to make sure that traffic is not delivered to the wrong destination. After trail set-up completion, TTI is used to detect any misconnections, in order to prevent delivery of traffic from the wrong source, and to allow for corrective action.

The TTI transports the Access Point Identifier (APId) of the trail's source.

A trail termination source function continuously transmits the TTI (see figure 23) containing the local (near-end) APId and TTI header (TxTI).

A trail termination sink function compares the content of the accepted TTI (AcTI), identifying the remote (far-end) AP, with the provisioned "expected TTI" (ExTI), identifying the expected remote AP as a check on the execution and consistency of the provisioning operation at (intermediate) connection functions.

Refer to subclause 8.2.1.3 for the acceptance and mismatch detection process specification.

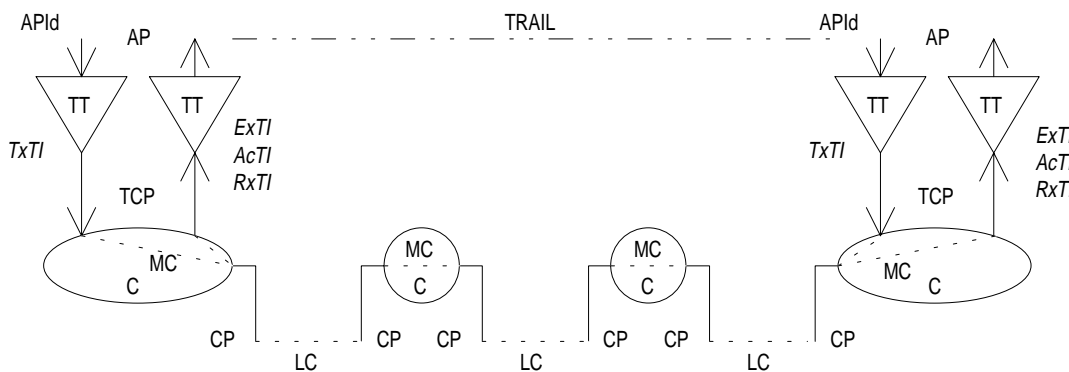

Figure 23: A bi-directional trail and its trace identifier parameters

**Definition of TTI**

**Mode 1**

The TTI, shown in table 5, is a 16 byte string containing the 15 byte APId and a 1 byte header. The MSB of the header is a "1", the remaining 7 bits contain the CRC-7 value of the TTI. The MSB of the 15 APId bytes is "0".

The CRC-7 word is the remainder after multiplication by  $x^7$  and then division (modulo 2) by the generator polynomial  $x^7 + x^3 + 1$ , of the polynomial representation of the TTI with the CRC bits set to binary zeroes (see note).

NOTE 1: Contrary to e.g. CRC-4 procedure in 2 Mbit/s signals, the CRC-7 word is static because the date is static (the TTI represents the source address). This means the CRC-7 checksum can be calculated a priori over the TTI.

When representing the contents of the check block as a polynomial, the first bit in the block, i.e. bit 1 of byte 0, should be taken as being the most significant bit. Similarly,  $C_1$  is defined to be the most significant bit of the remainder and  $C_7$  the least significant bit of the remainder.

The 16 TxTI, 16 ExTI and 16 AcTI bytes are transferred via the Management Point to and from the trail termination function.

Table 5: Trace Identifier contents

TTI byte #		value (bit 1,2,...,8)							APId byte #
0	1	$C_1$	$C_2$	$C_3$	$C_4$	$C_5$	$C_6$	$C_7$	--
1	0	X	X	X	X	X	X	X	1
2	0	X	X	X	X	X	X	X	2
:	:				:				:
15	0	X	X	X	X	X	X	X	15

**Mode 2**

For backward compatibility, to support VCs/STM-Ns not containing TTIs (from old equipment), the "expected TTI" code shall not be provisioned. In such a case, the received TTI is assumed to be a "constantly repeating single byte".

NOTE 2: With this method, new equipment is capable of detecting a misconnection to other new equipment when expecting the signal from old equipment.

## 7.2 Trail Signal Label (TSL)

The TSL supports two applications. It identifies:

- 1) whether the received signal is (supervisory-)unequipped or equipped (process within the termination function);
- 2) the payload composition / type (process within the adaptation function).

### Definition of unequipped VC signal:

- an all "0s" signal label;
- an all "0s" trail trace identifier;
- an all "0s" network operator byte;
- a valid VC BIP;
- an unspecified remainder of the VC (i.e. VC payload, other overhead).

NOTE: In future, it may be a requirement to generate an unequipped VC as an all-ZEROs signal in the entire VC.

### Definition of supervisory-unequipped VC signal:

- a valid trail trace identifier;
- an all "0s" signal label;
- an all "0s" network operator byte;
- a valid VC BIP;
- a valid RDI and REI;
- an unspecified remainder of the VC (i.e. VC payload, other overhead).

The VC supervisory-unequipped signal is an enhanced unequipped VC and is detected as an unequipped VC.

### 7.2.1 Unequipped signal application

NOTE 1: This subclause does not apply to supervisory-unequipped signals.

The unequipped signal indicates to downstream transport processing functions that the connection is not bound to, or not connected (via a matrix connection) to a termination source function.

If an unequipped VC signal is received, almost every bit in the VC is unspecified. Consequently, defect reporting of unspecified bits during an unequipped condition should be suppressed (i.e. cTIM, cRDI). Also, far-end PM processing is not possible (RDI and REI are undefined).

One of the possible errors which may occur while the network is being provisioned by the network manager is the unintended release of a matrix connection, resulting in an open connection matrix output (i.e. not connected to a connection matrix input). In this case, the transmitted signal will be the unequipped VC signal (refer to subclause 8.2.2.7). The receiving termination function can detect this disconnection by evaluating the signal label byte / bits for code '0' (unequipped). Formally, the reception of a signal label code '0' is not a signal label mismatch defect, but rather a "loss of signal" condition (see note 2).

NOTE 2: The unintentionally removed matrix connection and the broken cable / fiber both result in an unplanned disconnection.

Connection functions (figure 24) (see note 3) represent the switch matrices in network elements. A connection function has a number of inputs and a number of outputs (see note 4). The number of inputs may or may not be equal to the number of outputs. All outputs may or may not be connected to inputs.

NOTE 3: The connection functions in the figure show three connection points, by which the connection function is connected to adaptation functions in the server layer, and one termination connection point, by which the connection function is connected to a trail termination function in the same layer.

NOTE 4: The functionality of the connection function is described as a "space switch" in ITU-T Recommendation G.783 [12]. Timeslots (e.g. VC-12's in a VC-4) are represented by separate signals.

Outputs which are not connected to an input transmit an idle signal: the unequipped VC signal (UNEQ). This suppresses failure notifications from downstream adaptation functions.

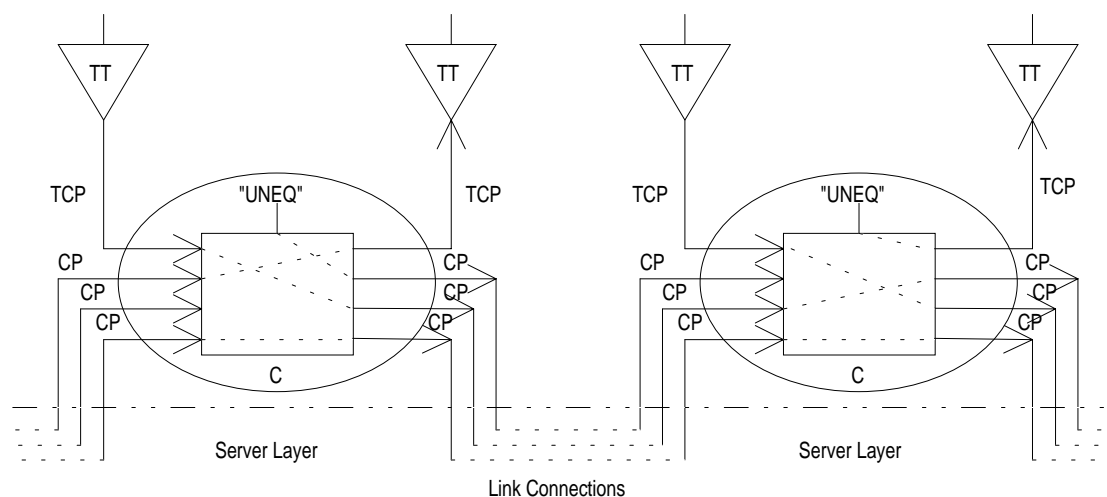

**Figure 24: Generation of unequipped VC in connection functions**

Not all equipment will have a real connection function (i.e. switch matrix) implemented, and in such cases less than 100 % of the trail termination functions may be installed or operational. If this is intentionally the case, the associated AUs (TUs) should carry unequipped VCs. The connection points in such equipment represent a "virtual" connection function and the outputs of this "virtual" connection function are not connected to inputs.

## 7.2.2 Supervisory-unequipped signal application

In addition to the unequipped signal application, the supervisory-unequipped allows enhanced supervision of connections.

Outputs which are not connected to an input transmit an idle signal - the unequipped VC signal (UNEQ) - which is replaced by the supervisory-unequipped signal if the termination supervisory source (TTs\_So) function is present.

The (tandem) link connection is connected (figure 25) to two trail termination supervisory functions, via Matrix Connections (MCs) in the supervisory-unequipped Connection function (Cs). The trail termination supervisory source function (TTs\_So) supplies a supervisory-unequipped signal. The Trail Termination supervisory Sink function (TTs\_Sk) monitors the signal.

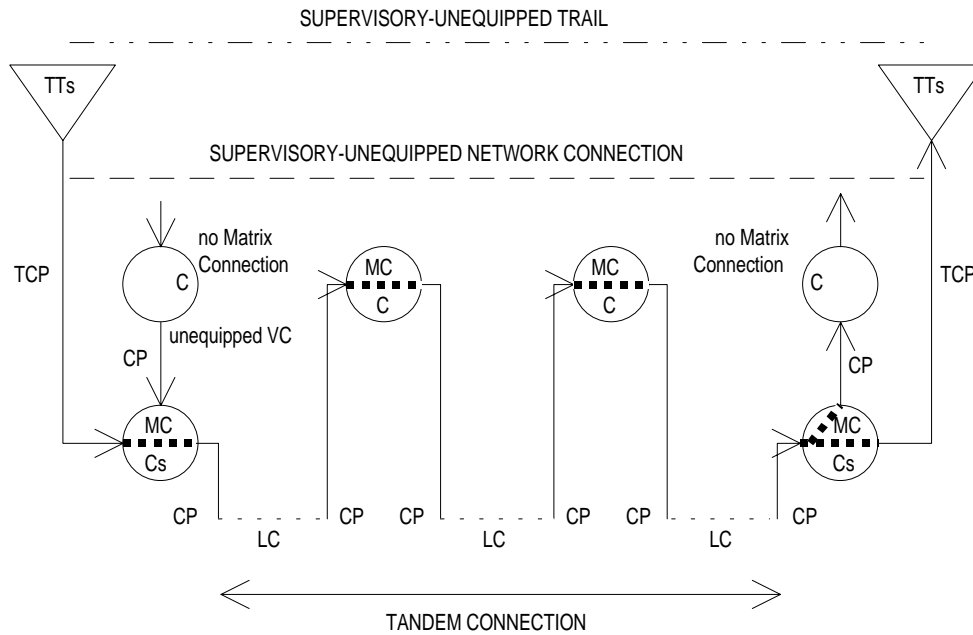

Figure 25: Generation and monitoring of supervisory-unequipped VC

### 7.2.3 Adaptation function selection supervision process

An Adaptation source function transmits the TSL (TxSL) which identifies the local (near-end) selected payload type and hence the adaptation or composition (see note 1) of adaptation function type(s) (see note 2). The TSL code acts as an adaptation source function identification code. The exact coding of the TSL is described in the respective adaptation functions in the other parts of the present document.

NOTE 1: The identification of a composition of adaptation function types by one TSL code is due to the limited number of code values per TSL.

NOTE 2: A particular adaptation function type serves a particular type client layer. An other adaptation function type serves another type client layer.

An adaptation sink function compares the content of the accepted TSL (AcSL) (see note 3), identifying the remote (far-end) adaptation function, with the "Expected TSL" (ExSL), identifying the local adaptation function as a check on consistency between the provisioning operation at each end of the trail.

NOTE 3: Refer to subclause 8.2.1.2 for the definition of AcSL.

For backward compatibility (to interwork with old equipment not containing equipped-specific TSLs), every equipped-specific "expected TSL" code is matched by the "equipped - non specific" TSL code (code "1").

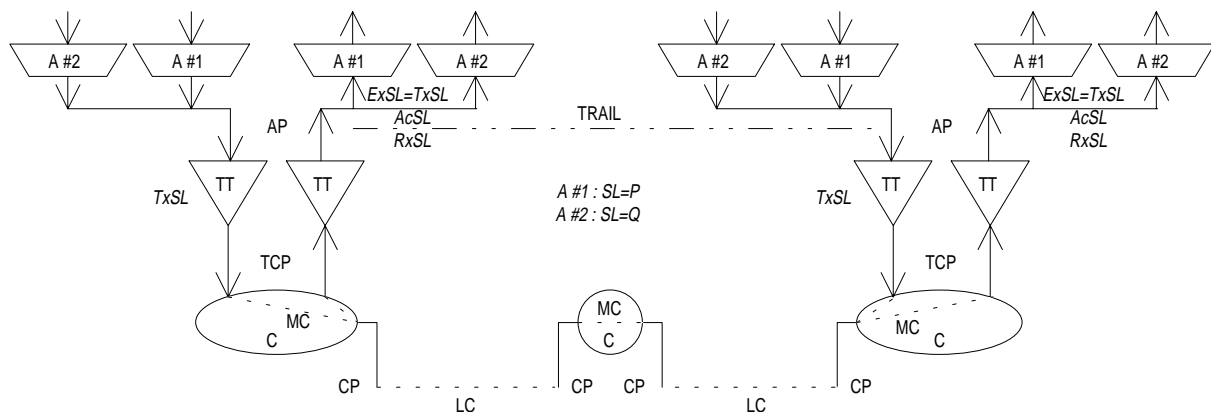

Figure 26: A bi-directional trail and its Signal Label parameters

Figure 26 shows an example of a trail which is terminated in network elements which include two adaptation function types (type #1 and #2). Both network elements have to be provisioned to activate the same adaptation function type. Mis-provisioning, for example type #1 at trail source and type #2 at trail sink, can cause uncontrolled behaviour of the signal output by the adaptation sink function.

## 7.2.4 Connection monitoring application

The availability of tandem connections (see note) which do not carry live traffic / services (i.e. they are not part of a network connection) is monitored by means of adaptation characteristics: LOP and AIS.

NOTE: A tandem link connection is a series of link connections and matrix connections which start and end with a LC. e.g.: LC - MC - LC - MC - LC. The minimum tandem connection is a single LC.

For the case that a tandem connection is set-up but not put into service, additional monitoring might be requested. This "pre-service monitoring" can be:

- a) through the application of the supervisory-unequipped signal as shown in figure 25;
- b) through the introduction of a test trail, which is for further study.

## 7.3 Error Detection Code (EDC)

To monitor the bit error performance during transmission, an EDC is added as part of the characteristic information output by the termination source. The termination sink function, at the other end of the trail, computes the EDC of the received characteristic information and compares it with the EDC value generated by the termination source function and transported within the characteristic information. Mismatches between the two indicate bit errors.

Examples of EDCs are: the SDH BIP-N and 2 Mbit/s CRC-4.

### Definition of BIP-N, CRC-4

Refer to ITU-T Recommendation G.708 [22], subclause 5.2.2, for a definition of BIP-N.

Refer to ITU-T Recommendation G.704 [8], subclause 2.3.3.5, for a definition of CRC-4.

## 7.4 Remote indicators

In order to support single ended operation, the defect status of, and the number of detected error detection code violations within, the characteristic information monitored at the trail termination sink shall be conveyed back to the far-end trail termination source (via RDI and REI signals). Hence, in the case where the terminations lie in the domains of different operators, the Operations Systems (OSs) in both networks will have access to performance information from both trail ends, without the need for OS to OS information exchange.

### 7.4.1 Remote Defect Indicator (RDI)

RDI signals convey the defect status of the trail signal at the trail destination (i.e. at trail termination sink function) back to the trail origin (i.e. trail termination source function). This mechanism allows alignment of the near-end and far-end performance monitoring processes.

Examples of RDI signals are the FERF bits in SDH signals, the A-bit in ITU-T Recommendation G.704 [8] structured 2 Mbit/s signals and the alarm indication bit in other PDH multiplex signals.

Figure 27 illustrates the RDI insertion and detection / processing for a multiplex section. Figure 28 illustrates the process for a VC-4 Path:

- at node A the near-end information represents the performance of the unidirectional section / path from B to A, while the far-end information represents the performance of the unidirectional section / path from A to B;
- at node B the near-end information represents the performance of the unidirectional section / path from A to B, while the far-end information represents the performance of the unidirectional section / path from B to A.

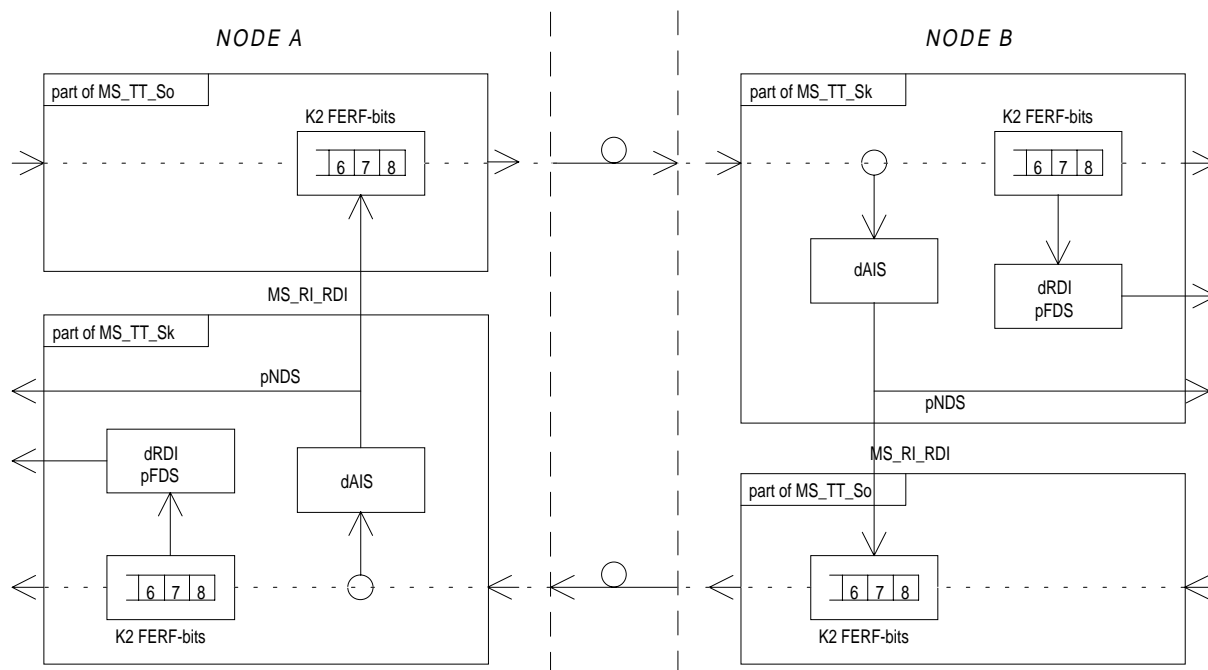

Figure 27: RDI insertion control example (multiplex section)

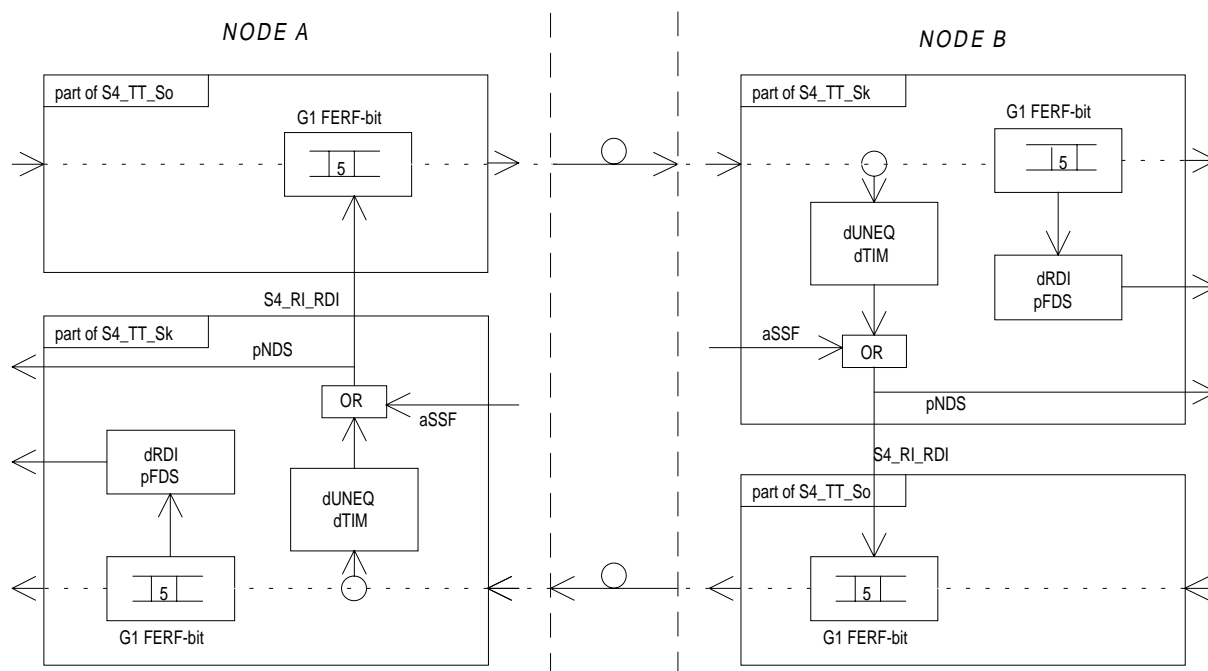

Figure 28: RDI insertion control example (VC-4 path)

## 7.4.2 Remote Error Indicator (REI)

REI signals contain either the exact or truncated (see note) number of error detection code violations detected in the trail signal at the trail termination sink. This information is conveyed to the trail termination source. This mechanism allows alignment of the near-end and far-end performance monitoring processes. Examples of REI signals are the FEBE bits in SDH signals and the E-bit in ITU-T Recommendation G.704 [8] structured 2 Mbit/s signals.

NOTE: Refer to the specific atomic functions to determine between exact or truncated number of EDCV transport in the REI.



Figure 29 illustrates the REI insertion and extraction / processing for a VC-4 bi-directional path:

- at node A the near-end information represents the performance of the unidirectional path from B to A, while the far-end information represents the performance of the unidirectional path from A to B;
- at node B the near-end information represents the performance of the unidirectional path from A to B, while the far-end information represents the performance of the unidirectional path from B to A.

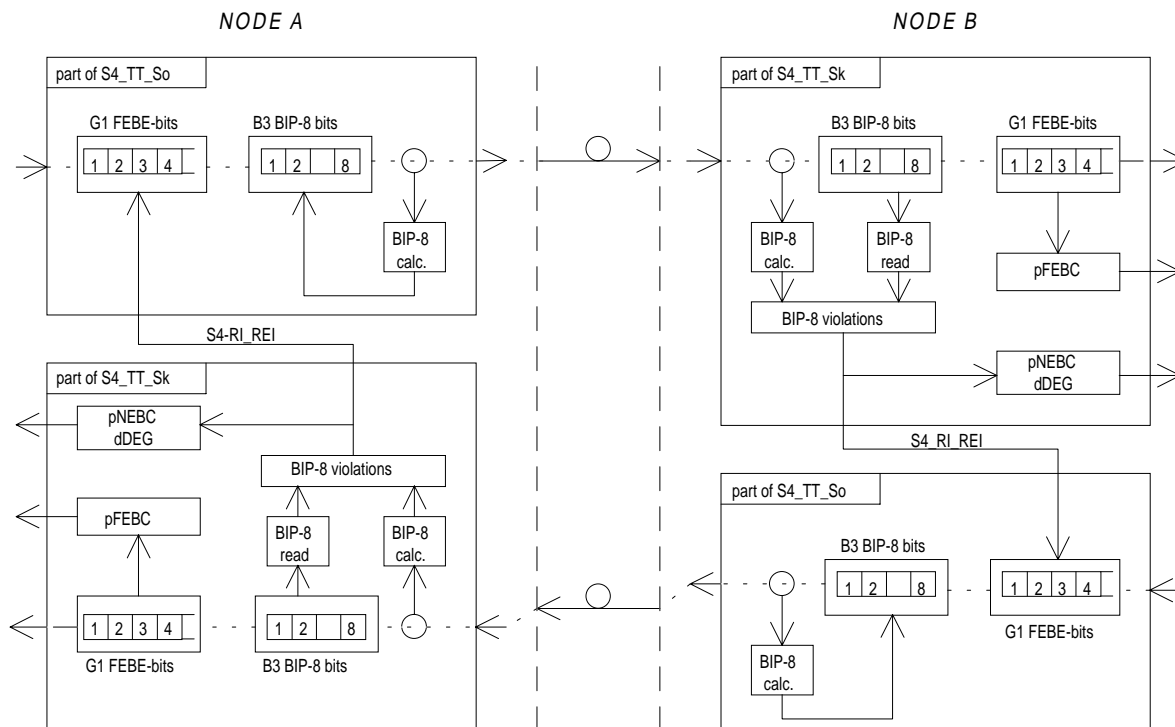

Figure 29: REI insertion control example (VC-4 path)

## 7.5 Alarm Indication Signal (AIS)

The AIS is an all-ONES characteristic or adapted information signal. It is generated to replace the normal traffic signal when it contains a defect condition in order to prevent consequential downstream failures being declared and alarms being raised.

All-ONES (AIS) insertion in the sink direction is controlled as follows: every atomic function inserts all-ONES on locally detected defects only, with one of the defects being incoming AIS from upstream atomic functions.

Figure 30 illustrates this process. Due to a LOF defect (STM1dLOF) the OS1/RS1\_A\_Sk inserts the all-ONES signal. This signal is propagated through the RS1 layer. The MS1\_TT\_Sk detects this all-ONES signal by monitoring bits 6 - 8 of K2. The MS1/S4\_A\_Sk detects the all-ONES signal by monitoring the pointer bytes H1, H2. As a consequence both functions insert all-ONES at their outputs (i.e. they "refresh" the all-ONES signal). This behaviour is continued in the other client layers.

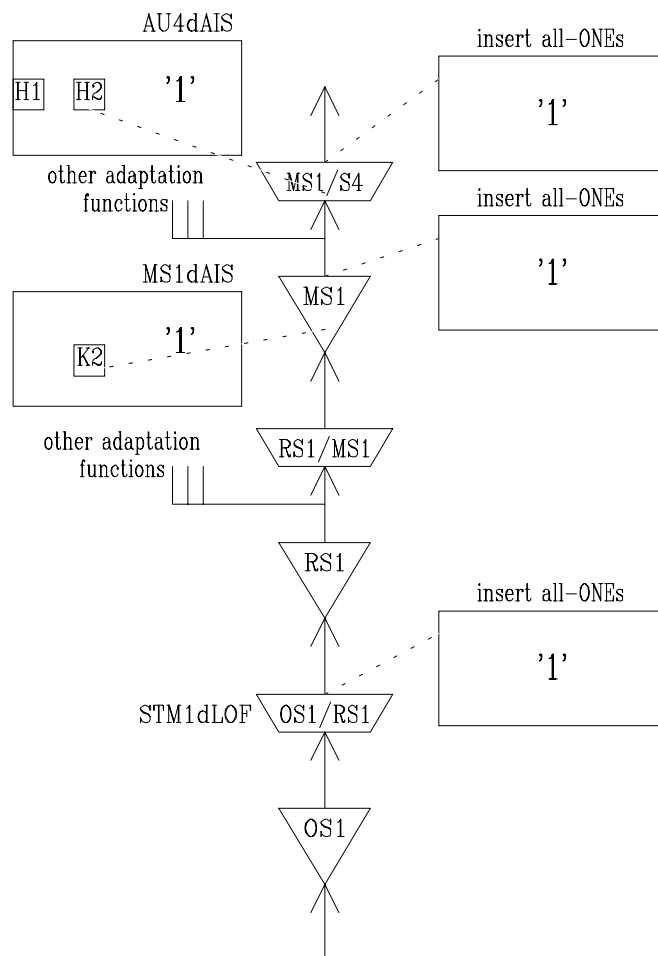

**Figure 30: All-ONES (AIS) insertion and propagation in the sink direction in case of STM1dLOF**

As soon as the direction through the layered structure reverts from the sink direction into the source direction, the all-ONES (AIS) signal becomes one of the defined AIS patterns (figure 31):

- MS<sub>n</sub>-AIS (n = 1,4,16) in case the RS<sub>n</sub>/MS<sub>n</sub>\_A\_Sk is connected to the RS<sub>n</sub>/MS<sub>n</sub>\_A\_So. This is the case in a STM-n regenerator;
- AU4-AIS in case the MS<sub>n</sub>/S4\_A\_Sk is connected to the MS<sub>n</sub>/S4\_A\_So. This is the case in a VC-4 Add-Drop Multiplexer (ADM) and a VC-4 Digital Cross Connect (DXC);
- TUm-AIS (m = 12,2,3) in case the S4/Sm\_A\_Sk is connected to the S4/Sm\_A\_So. This is the case in a VC-m ADM and a VC-m DXC;
- PDH AIS: Ex-AIS, a complete all-ONES signal, in the CCITT Recommendation G.703 [7] type signal. PUX-AIS, a PDH tributary unit all-ONES signal within the aggregate signal; for example a single 8 Mbit/s tributary signal containing all-ONES and correct justification control, within the 34 Mbit/s aggregate signal.

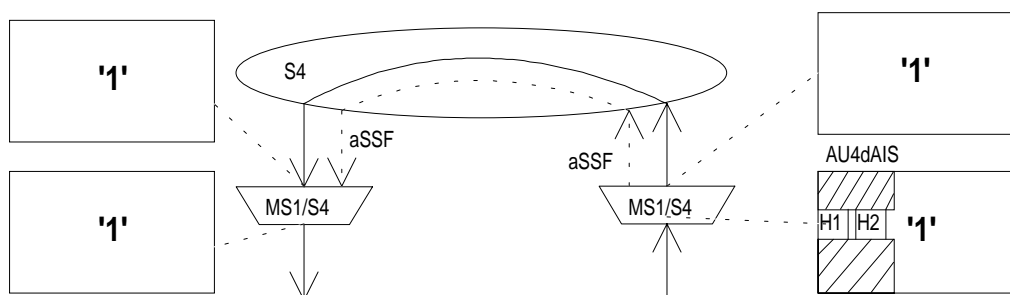

**Figure 31: All-ONES propagation from sink to source direction**

The all-ONES and aSSF signal applied at the input of the MS1/S4\_A\_So (figure 32) results in the generation of an all-ONES signal at the output. The MS1\_TT\_So and the other MS1 adaptation functions (e.g. MS1/OW\_A\_So) add the MSOH to the all-ONES signal. The RS1\_TT\_So and the RS1 adaptation functions add the RSOH. The result is the so called AU-4 AIS signal. This signal is transmitted to the far-end. The STM-1 signal passes through the functions up to the MS1\_TT\_Sk. Then the MS1/S4\_A\_Sk function detects AU-4 AIS. It declares the AU4dAIS defect and inserts all-ONES at its output.

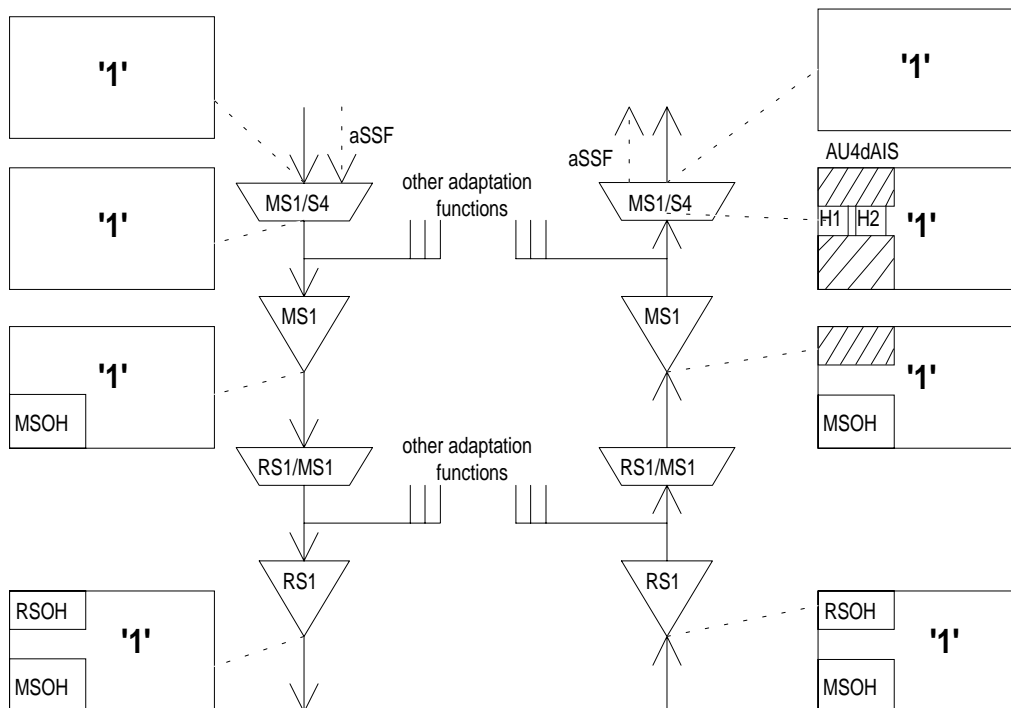

**Figure 32: All-ONES (AIS) generation in the source and detection in the sink direction**

Similarly, the reception of an all-ONES signal at the S4/S12\_A\_So results in the generation of an all-ONES (TU) signal at the output of the function. This signal is multiplexed with the other TUs, after which the VC-4 overhead, AU-4 pointer, MSOH and RSOH are added. The result is a STM-N signal with a TU carrying TU-AIS.

## 7.6 Non-intrusive monitoring of characteristic information at connection points

Non-intrusive monitoring of characteristic information at connection points is an application that may be used for fault localization.

If a trail termination sink function detects a disturbance it may not be obvious where this disturbance is located. The TT\_Sk indicates that there is a disturbance of a certain kind, not where it is.

To locate such a disturbance, the trail is viewed as a series of link connections. At the end of every link connection a non-intrusive monitoring termination sink function may be used to monitor the characteristic information at that point. See figure 33.

Starting at the TT\_Sk and going towards the TT\_So, the fault is located between those two termination sink functions of which the upstream function reports disturbance free performance while the other reports the disturbance condition.

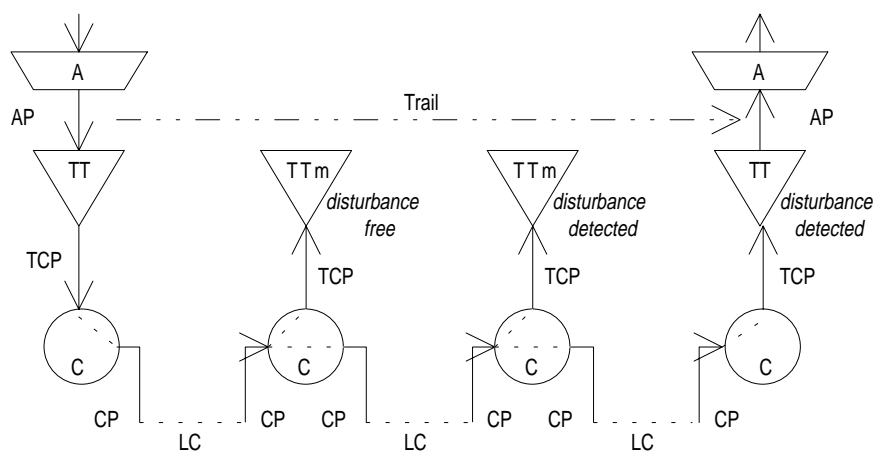

**Figure 33: Monitored trail; the 2 intermediate TTm\_Sk functions act as non-intrusive monitoring termination sinks**

In a similar manner, this fault location can be performed on a tandem connection which transports a supervisory-unequipped VC. See figure 34.

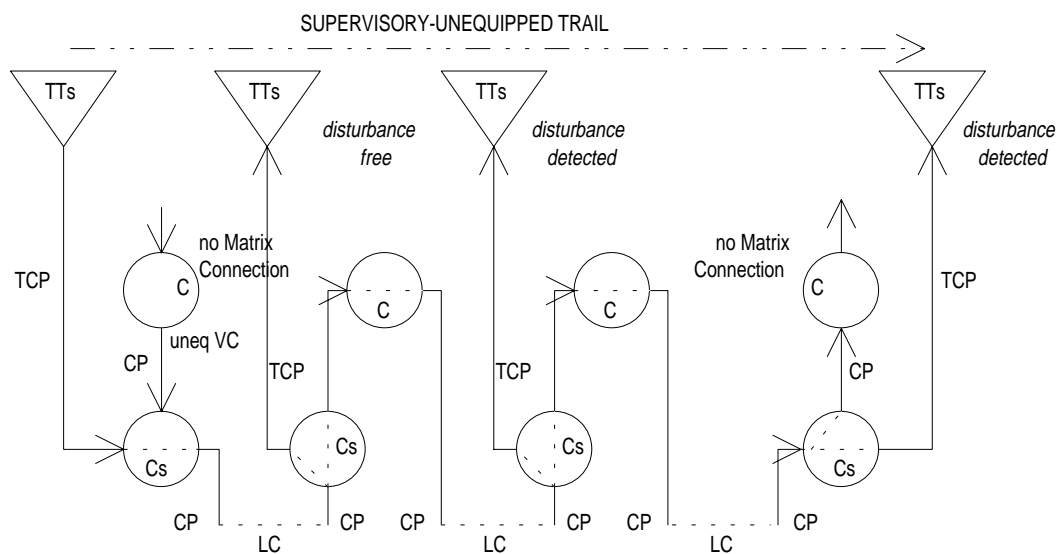

**Figure 34: Monitored supervisory-unequipped trail**

## 7.7 Signal fail and signal degrade

### 7.7.1 Server Signal Fail (aSSF) signal

The aSSF signal (generated by the adaptation sink function) informs the next downstream function of the "signal fail" condition of the associated data signal (which contains, due to that "signal fail" condition, the all-ONEs (AIS) pattern).

The aSSF signal, when connected to a connection function with protection functionality, represents the Signal Fail (SF) conditions.

### 7.7.2 Server Signal Fail failure (fSSF)

#### **Individual network layer management**

Managing network layers in isolation, i.e. when no information is available from the server layer, is an application indicated in ITU-T Recommendation G.803 [6]. For such case, the layer manager can not rely on failure reports from the server layers to obtain an accurate overview of the fault status of its incoming signals. As most trail termination functions do not detect incoming AIS to report a server layer fault, the layer and its manager have to be informed of such fault by means of the server signal fail signal / report.

On reception of an SSF failure, the layer manager may initiate a re-routing of the associated traffic via its layer connection functions.

#### **Severity control of protection reports**

The severity of a maintenance alarm is often related to the interruption of a traffic signal. If the signal is interrupted, a prompt maintenance alarm is to be activated.

When that traffic signal is transmitted via a protected trail or protected subnetwork connection (refer to clause 9), interruption of the signal in either the working or protection trail/SNC "does not affect" the transport of the signal over the protected trail/SNC. The protection function selects the other trail/SNC. If, however, both working and protection trail/SNC experience a fault, the transport of the signal is interrupted.

In the first case, a deferred maintenance alarm is to be activated, while in the second case a prompt maintenance alarm is required.

The (protection) trail termination function immediately following the (protection) connection function reports the fault status of the protected signal. If the signal output by the (protection) connection function contains all-ONEs (AIS), the protection failed and a prompt maintenance alarm is typically activated. The protection may have failed due to a double fault condition, or a single fault condition and an external protection switch request (refer to subclause 9.2.4) forcing the protection switch to select the failed trail/SNC.

### 7.7.3 Server Signal Degrade (aSSD) signal

The aSSD signal informs the next downstream function of the "signal degrade" condition of the associated data signal.

The aSSD signal is defined only in adaptation sink function in protection sub-layers. The signal relays the aTSD signal generated by the trail termination sink function towards the protection connection function in the protection sublayer. Refer to subclause 9.3.

### 7.7.4 Trail Signal Fail (aTSF) signal

The aTSF signal (generated by a trail termination sink function) informs the next downstream function(s) of the "signal fail" condition of the associated data signal (which contains, due to that "signal fail" condition, the all-ONEs (AIS) pattern).

The aTSF signal, when connected to a connection function with protection functionality, represents a Signal Fail (SF) conditions.

## 7.7.5 Trail Signal Degrade (aTSD) signal

The aTSD signal (generated by a trail termination sink function) informs the next function(s) of the "signal degrade" condition of the associated data signal.

The aTSD signal is only connected to a connection function with protection functionality, and represents the Signal Degrade (SD) conditions.

---

# 8 Supervision process

## 8.1 Introduction

The supervision process philosophy is based on the concepts underlying the functional model of ITU-T Recommendation G.803 [6] and the information model of ETS 300 304 [3] which distinguishes between Transmission and Equipment supervision processing.

Transmission and equipment supervision processes are concerned with the management of the transmission resources in the network and is only interested in the functionality which is being provided by a Network Element (NE). It requires a functional representation of an NE that is implementation independent. Any equipment faults are represented by the unavailability of the affected functions because the transmission management has no knowledge of the equipment as such. Most functions monitor the signals they are processing for certain characteristics and provide performance information or alarm conditions based on these characteristics. Therefore, transmission supervision processing provides information on the external interface signals that are processed by an NE.

Equipment supervision processing is concerned with the fault localization and repair of the equipment itself. Its purpose is to answer the classic questions: "who to send where to repair what?" It does not require a knowledge of the transmission network, other than that the equipment faults may have been categorized to indicate the urgency (e.g. prompt, deferred, mei (maintenance event information) (see note)) of the fault.

NOTE: Refer to ITU-T Recommendation M.20 [23].

The basic functions of the supervision process and their inter-relationships are depicted in figure 35. Figure 36 illustrates three major process groups, and figures 37, 43, and 44 identify the basic functions within these groups. Supervision terms and variables used throughout the present document are defined in subclauses 3.2 and 3.3.

The supervision process describes the way in which the actual occurrence of a disturbance or fault is analysed with the purpose of providing an appropriate indication of performance and/or detected fault condition to maintenance personnel. The following terms are used to describe the supervision process: anomaly, defect, consequent action, fault cause, failure and alarm.

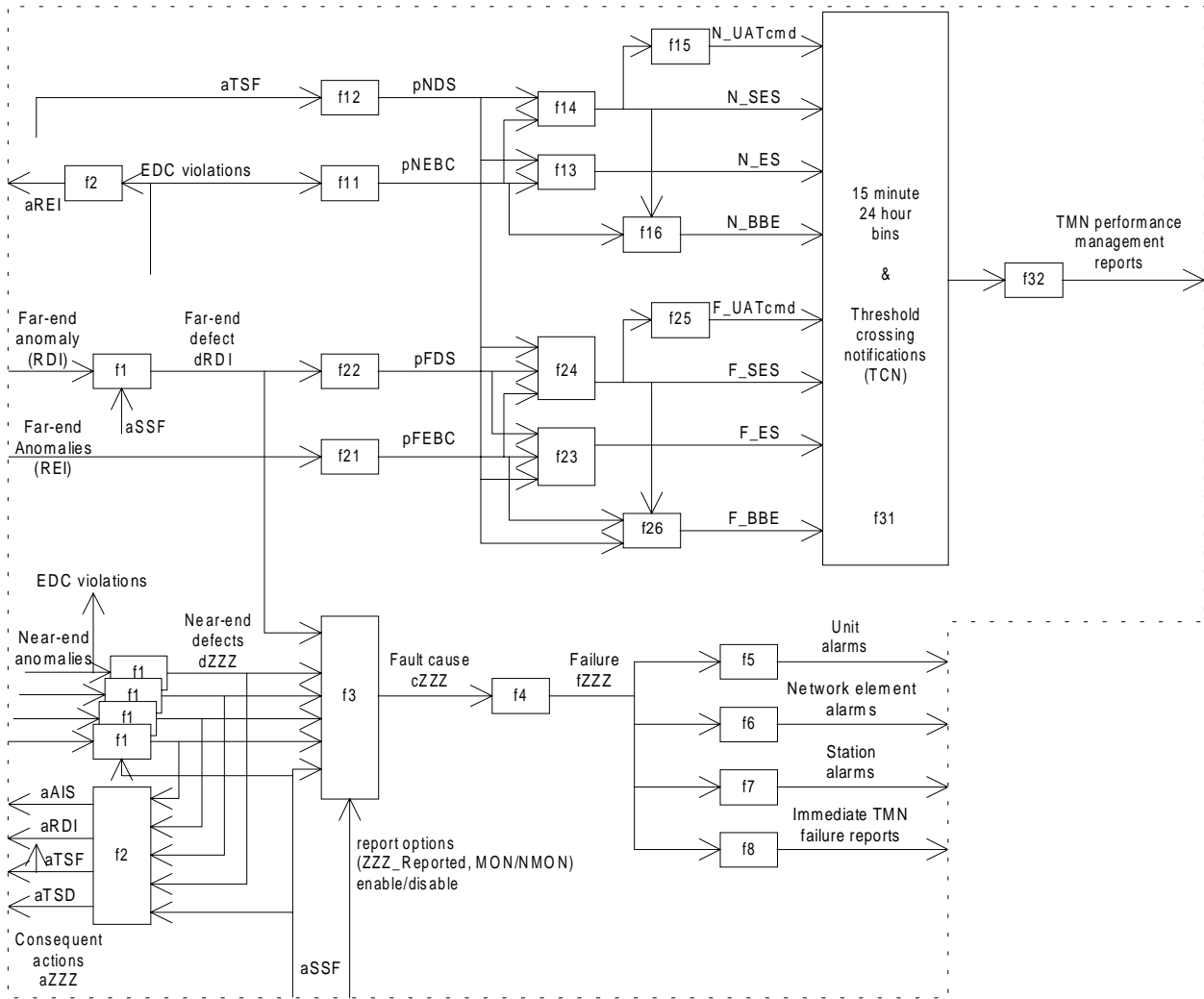

**Figure 35: Fault management and performance monitoring decomposition**

The supervision process is decomposed into three major sub-processes; atomic function fault management and performance monitoring, EMF fault management, and EMF performance monitoring (figure 36). These sub-processes are described in subclauses 8.2, 8.3 and 8.4.

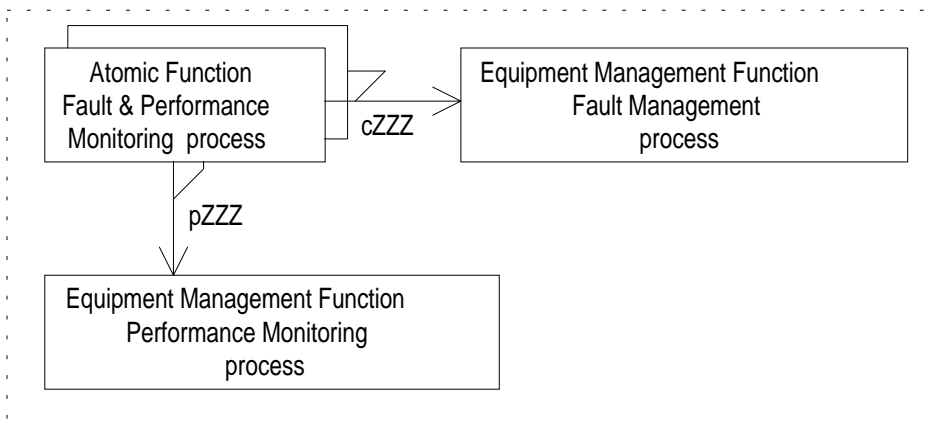

**Figure 36: Decomposition of supervision process**

## 8.2 Atomic function fault management

Figure 37 shows the main supervision process related (sub)processes within trail termination and adaptation functions. These processes are referred to as "filters" and are introduced in this subclause.

Filter	Function
f1	integration of anomalies into defects
f2	consequent action control
f3	correlation of defects; result is fault cause (correlated defect)
f11	Near-end errored block counting
f12	Near-end defect second determination process
f21	Far-end errored block counting
f22	Far-end defect second determination process

Filters f1, f2, and f3 are components of the fault management process located within the atomic functions. Filters f11, f12, f21, and f22 are components of the performance monitoring process located within the atomic function. The output signals cZZZ (e.g. cTIM) are the input signals for the EMF fault management process (subclause 8.3), while the output signals pZZZ (e.g. pN\_EBC) are the input signals for the EMF performance monitoring process (see subclause 8.4).

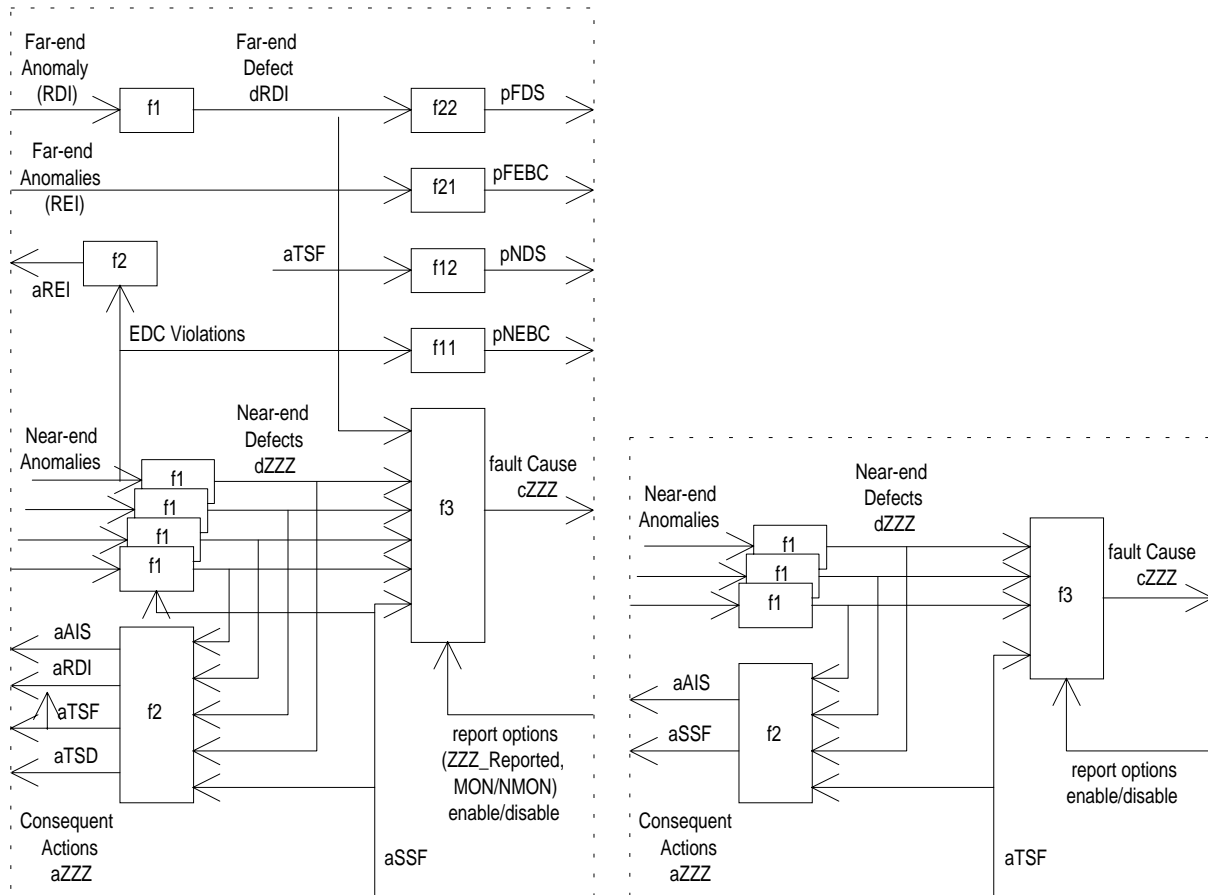

**Figure 37: Fault management and performance monitoring inside trail termination (left) and adaptation (right) functions**



## 8.2.1 Defect filter f1

### 8.2.1.1 Introduction

Two classes of defects are distinguished: transmission, and equipment defects. Transmission defects which are not dedicated to one specific layer are specified hereafter. Equipment defects are addressed at the end of this subclause in general terms. Defect filter f1 integrates anomalies into defects by performing a persistency check.

Each atomic function specified in the present document monitors for (a subset of) the following transmission defects:

signal loss	dLOS	Loss Of Signal defect
	dUNEQ	unequipped VC signal defect
	dTF	Transmit Fail
alignment loss	dLOF	Loss Of Frame defect
	dLOM	Loss Of Multiframe defect
	dLOP	Loss Of Pointer defect
		Generically - dLOA: Loss Of Alignment defect
mis-connected traffic	dTIM	Trace Identifier Mismatch defect
mis-composed payload	dPLM	Payload Mismatch defect
bit errors	dDEG	Signal Degrade defect
all-ONEs signal	dAIS	Alarm Indication Signal defect
remote defect indication	dRDI	Remote Defect Indicator defect
protocol faults	dFOP	e.g. MSP protocol defect

**Table 6: Defects generated in trail termination, adaptation and connection functions**

Termination sink	Adaptation sink	Connection	Termination source
dAIS	dAIS	dFOP	dTF
dUNEQ	dLOF		
dTIM	dLOM		
dDEG	dLOP		
dLOS	dPLM		
dRDI			

### 8.2.1.2 Trail Signal Label (TSL) and unequipped

The TSL identifies the presence of a payload and the signal type carried in the payload. Refer to subclause 7.2 for the application description.

The generic functionality of the mismatch detection process is illustrated in figure 38. The trail signal label is used as input for two processes, the payload mismatch detection process (within adaptation functions) and the unequipped detection process (within trail termination functions).

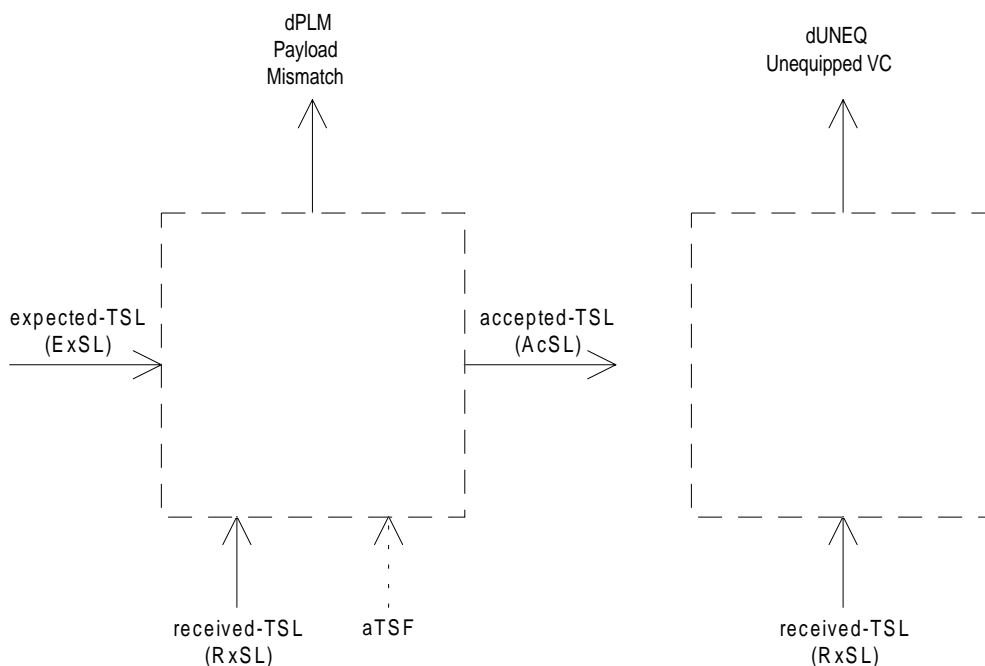

**Figure 38: Generic trail signal label acceptance, payload mismatch and unequipped detection process**

#### Expected trail signal label

The "expected TSL" shall be derived from the adaptation function type.

#### Received trail signal label acceptance

The value of the signal label passed to the management system should be an accepted value rather than the received value. The acceptance criteria are for further study.

#### Payload Mismatch (PLM) defect

The PLM defect (dPLM) shall be detected within a maximum period of 100 ms in the absence of bit errors.

The dPLM shall be cleared within a maximum period of 100 ms in the absence of bit errors.

The defect detection process and its operation during the presence of bit errors is for further study.

The defect shall be suppressed during the receipt of aTSF.

The defect shall be suppressed (cleared) if the incoming TSL code is "1" (equipped non-specific).

#### Unequipped (dUNEQ) defect

The Unequipped defect (dUNEQ) shall be detected if the "accepted TSL" is the unequipped indication (TSL code = 0).

NOTE 1: The value of the signal label used by the unequipped defect detection process should be an accepted value rather than the received value. The acceptance criteria are for further study.

Removal of unequipped defect is detected if the "accepted TSL" contains a non "unequipped" signal label (TSL code  $\geq 1$ ).

The dUNEQ shall be detected within a maximum period of 100 ms in the absence of bit errors.

The dUNEQ shall be cleared within a maximum period of 100 ms in the absence of bit errors.

NOTE 2: The consequent action of dUNEQ detection prevents (downstream) PDH defects from being declared when an unequipped signal is received. Should this consequent action not be taken, an unequipped signal which comprises all-ZEROs will cause a large frequency offset since the justification control bits will be zero. e.g. an all-ZEROs signal would cause the adaptation sink, if unconstrained, to generate a 2 048 kbit/s signal with an offset of 976 ppm. Since only 50 ppm is permitted this signal would not comply with the requirements of CCITT Recommendation G.703 [7].

### 8.2.1.3 Trail Trace Identifier (TTI)

The TTI transports the Access Point Identifier (APId) of the trail's source. Refer to subclause 7.1 for a description of the application and a definition of the TTI.

The generic functionality of the trace identifier (mismatch detection) process is illustrated in figure 39.

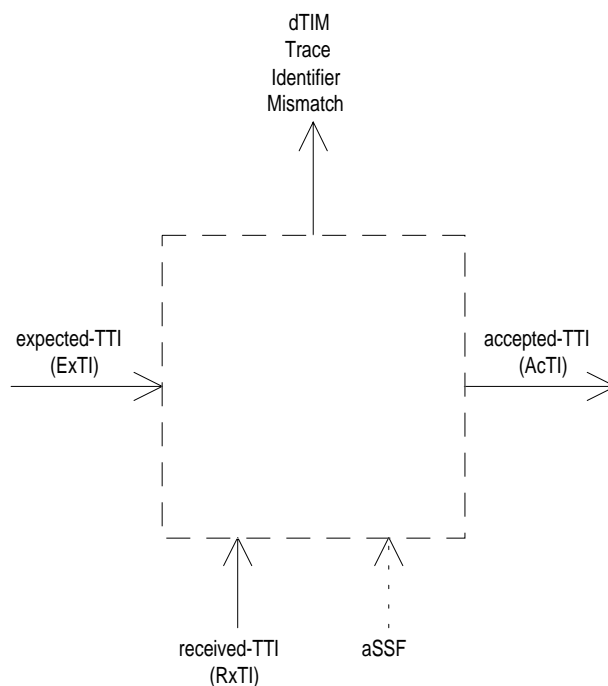

**Figure 39: Generic trail trace identifier (mismatch detection) process**

#### Expected trail trace identifier provisioning

The trail termination sink function receives the "expected TTI" via its management point. It can appear in one of the two modes defined in subclause 7.1.

#### Received trail trace identifier acceptance

The value of the trace identifier passed to the management system should be an accepted value rather than the received value. The acceptance criteria are for further study.

#### Trace Identifier Mismatch (TIM) defect

The Trace Identifier Mismatch defect (dTIM) shall be detected within a maximum period of 100 ms in the absence of bit errors.

The dTIM shall be cleared within a maximum period of 100 ms in the absence of bit errors.

The defect detection process and its operation during the presence of bit errors is for further study.

The defect shall be suppressed during the receipt of aSSF.

When interworking with old equipment refer to subclause 7.1.

It shall be possible to disable the trace identifier mismatch defect detection (TIMdis).

NOTE: Trace identifier mismatch defect detection should be disabled to perform APID numbering plan modifications without traffic interruption, to perform non-intrusive monitoring when the APID within the trace identifier is unknown (e.g. within a tandem connection), to support some (protection) applications in which a multipoint to point trail is/can be present.

#### 8.2.1.4 Degraded (DEG)

Bit errors in a signal are detectable by checking the signal's associated EDC for violations. Examples of EDCs are the SDH BIP-N and 2 Mbit/s CRC-4.

##### EDC Violation detection

The computed EDC shall be compared with the received EDC value in the following frame.

As the detection of AIS results in the declaration of a Severely Errored Second (SES), the Error Detection Code Violation (EDCV) process shall assume "zero" EDCVs in the incoming all-ONEs (AIS) signal during an incoming Server Signal Fail (aSSF) condition.

##### EDC violation counting

The result of the comparison, 0 or  $\geq 1$  EDC violation, shall be applied to the Near-end Errored Block Count (N\_EBC) counter. This N\_EBC counter shall count the errored blocks during one second intervals. At the end of the interval the count equals pN\_EBC.

The performance monitoring one second periods (subclause 8.4) are the one second interval boundaries.

##### DEG defect detection

Once every second, pN\_EBC shall be compared with DEGTHR. If  $pN\_EBC \geq DEGTHR$  the one second shall be declared BAD, otherwise it shall be declared GOOD.

The Degraded defect (dDEG) shall be detected if M consecutive BAD seconds have occurred.

The Degraded defect (dDEG) shall be cleared if M consecutive GOOD seconds have occurred.

DEGTHR and M shall be provisioned by the network manager with:

$$0 < DEGTHR \leq N \text{ and } 2 \leq M \leq 10.$$

Where N is the number of blocks in one second and M is the number of seconds in the (sliding) monitoring period.

Hysteresis is for further study.

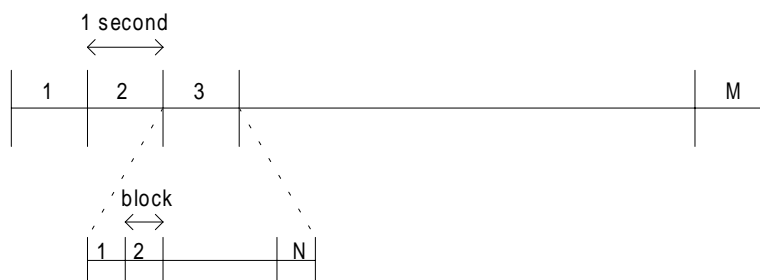

Figure 40: Signal degrade defect specification

#### 8.2.1.5 Remote Defect Indicator (RDI)

The RDI conveys back the defect status of the remote (far-end) sink function of the bi-directional trail. Refer to subclause 7.4.1.

Remote Defect Indication defect (dRDI) shall be detected if the RDI signal is active / set in five consecutive frames.

The dRDI detection process shall be stopped and the dRDI defect shall be cleared during an incoming Server Signal Fail (aSSF) condition.

dRDI shall be cleared if the RDI signal is inactive / cleared in five consecutive frames.

### 8.2.1.6 Loss of signal

#### PDH and SDH CCITT Recommendation G.703 [7] interfaces

A Loss Of Signal defect (dLOS) at 64 kbit/s (co-directional), 2 048 kbit/s, 8 448 kbit/s, 34 368 kbit/s, 139 264 kbit/s, and (electrical) 155 520 kbit/s interfaces shall be detected if the incoming signal has "no transitions", i.e. when the signal level is less than or equal to a signal level of Q dB below nominal, for N consecutive pulse intervals, where  $10 \leq N \leq 255$ .

The dLOS shall be cleared if the incoming signal has "transitions", i.e. when the signal level is greater than or equal to a signal level of P dB below nominal, for N consecutive pulse intervals, where  $10 \leq N \leq 255$ .

A signal with "transitions" corresponds to a CCITT Recommendation G.703 [7] compliant signal.

The signal level P is maximum cable loss (per CCITT Recommendation G.703 [7]) + 3 dB below nominal.

The signal level Q is 35 dB below nominal. (It is greater than the maximum expected cross-talk level.)

Figure 41 illustrates the relationship of the various signal levels.

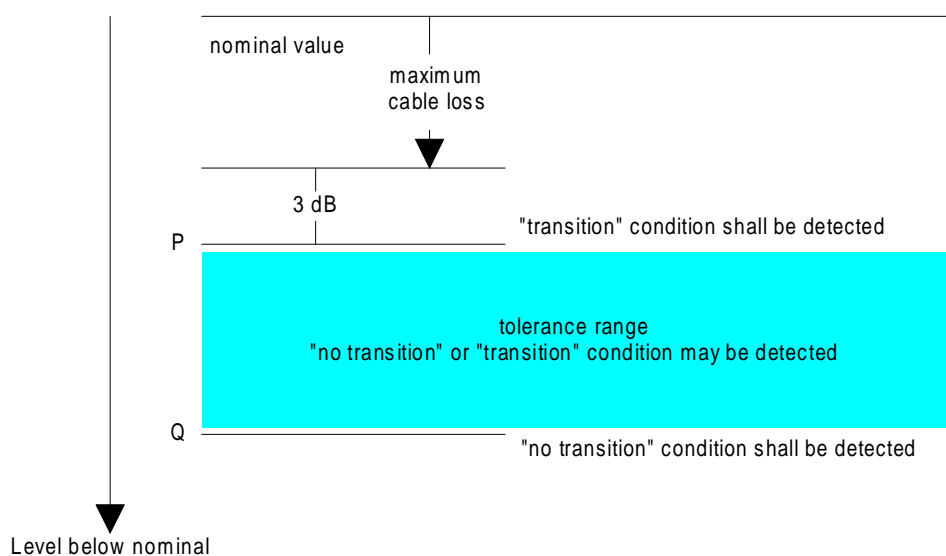

**Figure 41: Criteria for determination of transition conditions**

#### Optical STM-N interfaces

The optical STM-N LOS defect shall be detected when the received signal has degenerated to a level where SDH frame alignment would be interrupted, and the cause is evidently a drop of incoming power below operational level.

NOTE: This is a functional specification referring only to the quality of the incoming signal.

The timing requirements for detection and termination of the LOS defect are for further study.

### 8.2.1.7 Alarm Indication Signal (AIS)

#### PDH signals

The AIS defect in 2 048 kbit/s, 8 448 kbit/s, 34 368 kbit/s, and 139 264 kbit/s signals shall be detected if the incoming signal has X or less ZEROs in each of two consecutive Y bit periods.

The defect shall be cleared if each of two consecutive Y bit periods contains Z or more ZEROs or the Frame Alignment Signal (FAS) has been found.

The values of X, Y and Z are specified in the specific atomic functions.

## **SDH signals**

SDH specific AIS defect detection is performed on selected bits within the signal (ADAPTED INFORMATION OR CHARACTERISTIC INFORMATION).

The AIS defect (dAIS) shall be detected if the selected bits contain the all-ONEs pattern for a number of consecutive (multi-)frames.

The dAIS shall be cleared if the selected bits contain any pattern other than all-ONEs for a number of consecutive (multi-)frames.

Refer to the MSn\_TT\_Sk function for specification of MSndAIS. Refer to annex B for AU4dAIS and TUndAIS details.

### **8.2.1.8 Loss of frame, multiframe, pointer**

#### **STM-N LOF**

Refer to specific atomic functions.

#### **PDH LOF**

Refer to specific atomic functions.

#### **AU-4 & TU-m (m = 3,2,12) LOP**

Refer to annex B.

### **8.2.1.9 Failure of protocol**

The failure of protocol requirements are for further study.

### **8.2.1.10 Equipment defects**

Equipment defects (dEQ) may imply great performance impairments; i.e. signal transfer interruption. These defects which are implementation specific cannot be listed here explicitly. Nevertheless, equipment defects shall be reported per replaceable unit.

For the case where a replaceable unit is reported as being faulty (i.e. it contains an equipment fault) all the signals processed on that unit shall be assumed to be interrupted. The trail termination sink functions on that unit shall represent this by means of the activation of their performance parameter pN\_DS. This will result in the reporting of (severely) errored seconds or, more likely, unavailable seconds.

NOTE: The effect of equipment redundancy (replaceable unit protection) has to be included in the above specification. This is for further study.

### **8.2.1.11 Transmit Fail**

The Transmit Fail defect (dTF) is equipment specific.

## **8.2.2 Consequent action filter f2**

This subclause describes the consequent actions that can be generated by an atomic function within an NE as a result of anomalies/defects.

After a defect (see note) is detected, one or more of the following consequent actions may be requested:

- all-ONEs (AIS) insertion;
- RDI insertion;
- insert REI;
- unequipped signal insertion;
- generation of "Server Signal Fail (SSF)" signal;
- generation of "Trail Signal Fail (TSF)" signal;
- generation of "Trail Signal Degrade (TSD)" signal;
- (Automatic) Laser Shutdown (ALS/LS).

NOTE: For the case of REI, it is after anomaly detection.

**Table 7: Consequent action request generation in trail termination, adaptation and connection functions**

Termination sink	Adaptation sink	Connection
aAIS	aAIS	insert unequipped VC
aTSF	aSSF	
aTSD		
aRDI		
aREI		

Figure 42 shows how the aAIS, aRDI and aREI consequent action request signals control the associated consequent actions: insertion of all-ONEs, insertion of RDI code and insertion of REI value. Figure 42 also shows the location of aSSF, aTSF and aTSD consequent action requests.

Detected defects cause the insertion of the all-ONEs signal in Trail Termination sink functions. Detected defects cause the insertion of the all-ONEs signal in adaptation sink functions. The reception of a Server Signal Fail (SSF) indication causes the insertion of all-ONEs in the adaptation source. Refer to subclause 8.2.2.1 for details.

In case where the all-ONEs signal is inserted either in a trail termination sink or in the previous adaptation sink function, the RDI code is inserted in the associated trail termination source signal. i.e. the RDI code is inserted on detected defects or the reception of a SSF indication in a trail termination sink function (aRDI). Refer to subclause 8.2.2.2 for details.

Every frame, the number of detected EDC violations (aREI) in the trail termination sink function is inserted in the REI bits in the associated trail termination source signal. Refer to subclause 8.2.2.3 for details.

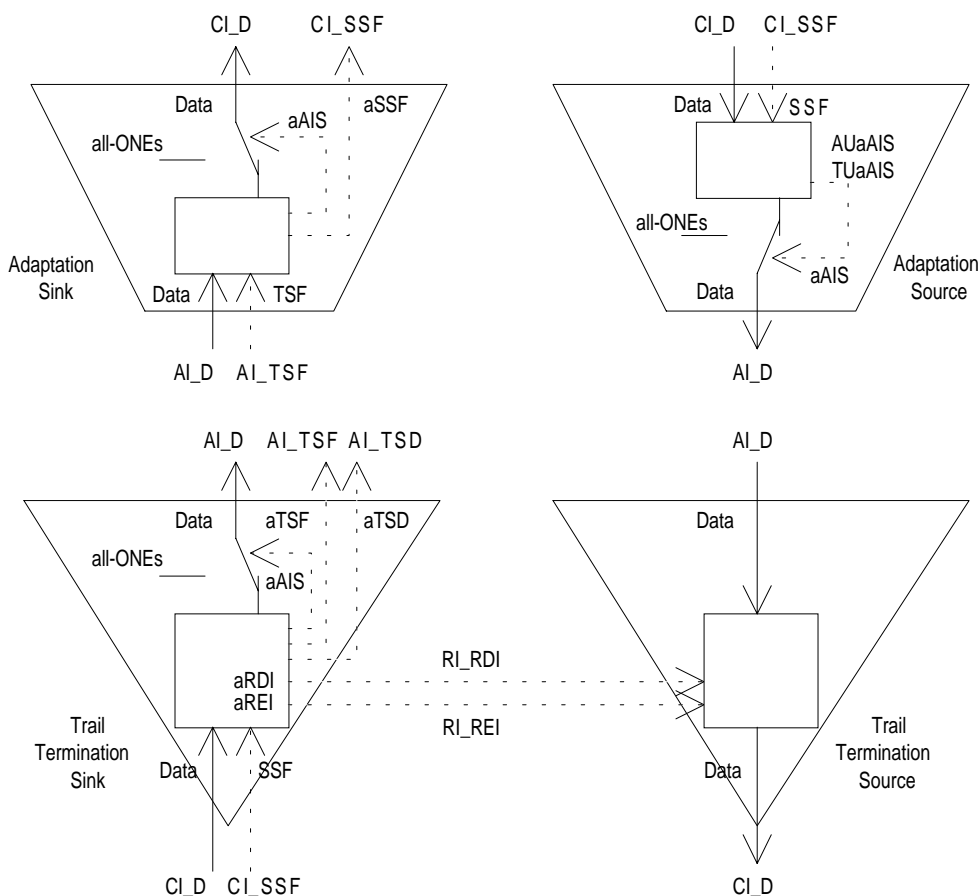

**Figure 42: Consequent Action control: AIS, RDI and REI**

A connection function inserts the unequipped VC signal at one of its outputs if that output is not connected to one of its inputs. Refer to subclause 8.2.2.7.

The behaviour of PDH path layer connection functions if an output is not connected to one of the inputs is for further study.

### 8.2.2.1 Alarm Indication Signal (AIS)

The all-ONEs (AIS) signal replaces the received signal under detected defect conditions in order to prevent downstream failures being declared and alarms being raised. Refer to subclause 7.5 for a description of the application and the insertion control.

The logic equations for the all-ONEs (aAIS) insertion request are (generically):

- **adaptation sink functions**

$$\mathbf{aAIS} \leftarrow \mathbf{dPLM \text{ or } dLOA \text{ or } dAIS}$$

NOTE 1: dLOA represents either dLOF, or dLOM or dLOP whichever is applicable in the atomic function.

- **termination sink functions**

$$\mathbf{aAIS} \leftarrow \mathbf{dAIS \text{ or } dUNEQ/dLOS \text{ or } dTIM}$$

NOTE 2: The term dAIS is applicable for the MS\_TT function. The term dLOS is applicable for physical section layer termination functions while dUNEQ represents a similar condition for the (SDH) path layers.



- **adaptation source functions**

$$\mathbf{aAIS} \quad \leftarrow \quad \mathbf{aSSF}$$

The termination sink, and adaptation sink and source functions shall insert the all-ONEs (AIS) signal within 2 (multi)frames after AIS request generation (aAIS), and cease the insertion within 2 (multi)frames after the AIS request has cleared.

### 8.2.2.2 Remote Defect Indicator (RDI)

Refer to subclause 7.4.1 for a description of the RDI application and the insertion control.

The logic equation for the RDI insertion request is (generically):

$$\mathbf{aRDI} \quad \leftarrow \quad \mathbf{dAIS/aSSF \text{ or } dUNEQ \text{ or } dTIM}$$

NOTE 1: In general Trail Termination functions do not detect dAIS. (The exception is the MS Trail Termination.) To ensure that the Trail Termination function is aware of the reception of the all-ONEs signal, the server layer (which inserted the all-ONEs signal on detected defect conditions) informs the client layer about this condition by means of the aSSF signal. In such case the dAIS term, in the aRDI expression, is replaced by aSSF.

NOTE 2: In the termination supervision (TTs\_Sk) function  $\mathbf{aRDI} \leftarrow \mathbf{aSSF}$  or (not dUNEQ) or dTIM.

The trail termination source function shall insert the RDI code within 2 (multi)frames after the RDI request generation (aRDI) in the trail termination sink function. It ceases RDI code insertion within 2 (multi)frames after the RDI request has cleared.

### 8.2.2.3 Remote Error Indication (REI)

Refer to subclause 7.4.2 for a description of the REI application and the insertion control.

The logic equation for the REI insertion request is (generically):

$$\mathbf{aREI} \quad \leftarrow \quad \mathbf{"\#EDCV"}$$

NOTE: The definition of the REI at the MS-N layer is under study; it has been proposed that MS-REI conveys the number of bit-interleaved errored blocks instead.

The trail termination source function inserts the REI value in the next REI bit(s).

### 8.2.2.4 Server Signal Fail (SSF)

aSSF signals are used to forward the defect condition of the server to the client in the next (sub-) layer, to:

- prevent defect detection in layers without incoming AIS detectors in trail termination sink functions (e.g. S4\_TT, S12\_TT);
- report the server signal fail condition in layers without incoming AIS detectors in trail termination sink functions;
- control the link connection AIS (e.g. AU-AIS) insertion in adaptation source functions;
- initiate protection switching / restoration in the (protection-)connection function.

The logic equation for SSF is (generically):

$$\mathbf{aSSF} \quad \leftarrow \quad \mathbf{dPLM \text{ or } dAIS/aTSF \text{ or } dLOA}$$

NOTE 1: In case the adaptation function does not detect the AIS defect, the dAIS term will be replaced by aTSF generated by the previous TT\_Sk.

NOTE 2: The term dLOA is the general indication for dLOF, dLOM or dLOP whichever is applicable.

### 8.2.2.5 Trail Signal Fail (TSF)

aTSF signals are used to forward the defect condition of the trail to the:

- adaptation sink function, to control all-ONEs (AIS) insertion in the function, when the function does not perform AIS defect detection; e.g. in S12/P12x\_A\_Sk;
- protection connection function in the trail protection sub layer, to initiate trail protection switching in that function;
- connection function in the same layer which performs a non-intrusively monitored SNC (SNC/N) protection scheme, to initiate SNC protection switching in that function. Refer to subclause 9.4.2.

The logic equation for TSF is (generically):

$$\mathbf{aTSF} \quad \leftarrow \quad \mathbf{dAIS/aSSF \text{ or } dUNEQ/dLOS \text{ or } dTIM}$$

NOTE 1: In general trail termination functions do not detect dAIS (the exception is the MS trail termination). To ensure that the trail termination function is aware of the reception of the all-ONEs signal, the server layer (which inserted the all-ONEs signal on detected defect conditions) informs the client layer about this condition by means of the aSSF signal. In such case the dAIS term, in the aTSF expression, is replaced by aSSF.

NOTE 2: In the termination supervision (TTs\_Sk) function  $\mathbf{aTSF} \leftarrow \mathbf{aSSF \text{ or } (not \ dUNEQ) \text{ or } dTIM}$ .

### 8.2.2.6 Trail Signal Degrade (TSD)

aTSD signals are used to forward the signal degrade defect condition of the trail to the:

- protection connection function in the trail protection sub layer, to initiate trail protection switching in that function;
- connection function in the layer to initiate sub-network connection protection switching in that function for the case of a non-intrusive monitored SNC (SNC/N) protection scheme. Refer to subclause 9.4.2.

The logic equation for TSD is:

$$\mathbf{aTSD} \leftarrow \mathbf{dDEG}$$

### 8.2.2.7 Unequipped Virtual Container (VC) signal

Unequipped indicating signals are generated by (virtual) connection functions. Refer to subclause 7.2.

If the output of a VC connection function is not connected to an input of that VC connection function, the VC originates at that connection function. In this case an unequipped VC shall be generated by the connection function.

NOTE: In cases where a VC originates at a "terminal multiplexer" or "line system" network element which has only a limited number of tributary port units (containing the path termination functions) installed, the STM-N aggregate signal could contain undefined VCs. To prevent such conditions, which cause failures and alarms, an unequipped VC or supervisory-unequipped VC should be inserted in the unoccupied VC time slots.

### 8.2.2.8 Unit Failure (UF)

aUF signals represent the defect status of the replaceable unit towards the equipment protection process.

### 8.2.2.9 (Automatic) laser shutdown (ALS/LS)

The Automatic laser shutdown function is not required for ETS 300 232 [2] laser types I-n, S-n.1, S-n.2, L-n.1, L-n.2, L-n.3, with n = 1, 4, 16. These lasers are within the class 1 IEC 825 specified optical safety levels.

The necessity of automatic laser shutdown function for optical amplifiers is for further study.

### 8.2.2.10 Server Signal Degrade (SSD)

aSSD signals are used to forward the degraded signal defect condition of the server to the client in the next sublayer, to:

- initiate protection switching in the protection connection function.

The logic equation for SSD is (generically):

$$\mathbf{aSSD} \quad \leftarrow \quad \mathbf{aTSD.}$$

### 8.2.3 Fault cause filter f3

A fault may cause multiple defect detectors to be activated. To determine, from the activated defects, which fault is present, the activated defects are correlated to obtain the fault cause.

**Table 8: Fault Causes per atomic function**

Termination sink	Adaptation sink	Connection	Termination source
cSSF (option)	cLOF	cFOP	cTF
cUNEQ	cLOM		cTD
cTIM	cLOP		
cDEG	cAIS (option)		
cLOS	cPLM		
cAIS (option)			
cRDI (option)			

The *cZZZ* fault causes (correlated defects) shall be activated if the expression is true. *cZZZ* shall be deactivated if the expression is false.

#### 8.2.3.1 Termination sink function

$$\begin{aligned} \mathbf{cUNEQ} &\quad \leftarrow \quad \mathbf{MON \text{ and } dUNEQ} \\ \mathbf{cTIM} &\quad \leftarrow \quad \mathbf{MON \text{ and } (not \text{ } dUNEQ) \text{ and } dTIM} \\ \mathbf{cDEG} &\quad \leftarrow \quad \mathbf{MON \text{ and } (not \text{ } dTIM) \text{ and } dDEG} \\ \mathbf{cRDI} &\quad \leftarrow \quad \mathbf{MON \text{ and } (not \text{ } dUNEQ) \text{ and } (not \text{ } dTIM) \text{ and } dRDI \text{ and } RDI\_reported} \\ \mathbf{cSSF} &\quad \leftarrow \quad \mathbf{MON \text{ and } aSSF/dAIS \text{ and } SSF\_Reported} \\ \mathbf{cLOS} &\quad \leftarrow \quad \mathbf{MON \text{ and } dLOS} \\ \mathbf{cAIS} &\quad \leftarrow \quad \mathbf{MON \text{ and } dAIS \text{ and } AIS\_Reported} \end{aligned}$$

It shall be an option to report SSF as a fault cause. This is controlled by means of the parameter *SSF\_reported*. The default shall be *SSF\_Reported* = false.

It shall be an option to report RDI as a fault cause. This is controlled by means of the parameter *RDI\_reported*. The default shall be *RDI\_Reported* = false.

It shall be an option to report AIS as a fault cause. This is controlled by means of the parameter *AIS\_reported*. The default shall be *AIS\_Reported* = false.

NOTE 1: *dUNEQ*, *dTIM*, *dDEG* and *dRDI* are cleared during an *aSSF/aTSF* condition. Refer to subclauses 8.2.1.2 to 8.2.1.5.

NOTE 2: In the *MS\_TT* function, defects of the server layer are detected by *dAIS* from the K2 byte and not through *aSSF*.

NOTE 3: By default, AIS as such is not reported. Instead trail terminations shall report (as an option) that the server (layer) failed to pass the signal (Server Signal Fail) if they receive the all-ONEs (AIS) signal. This reduces the declaration of "AIS failures" to one failure (fSSF) at the Trail Termination NE. No failures are generated at intermediate nodes in the (long) trail. Refer to subclause 7.7.2.

NOTE 4: Refer to subclause 8.5 for a MON description.

### 8.2.3.2 Termination supervisory sink function

cUNEQ	←	MON and dTIM and (AcTI = all "0"s) and dUNEQ
cTIM	←	MON and dTIM and (not dUNEQ and AcTI = all "0"s)
cDEG	←	MON and (not dTIM) and dDEG
cRDI	←	MON and (not dTIM) and dRDI and RDI_reported
cSSF	←	MON and aSSF and SSF_Reported

It shall be an option to report SSF as a fault cause. This is controlled by means of the parameter SSF\_reported. The default shall be SSF\_Reported = false.

It shall be an option to report RDI as a fault cause. This is controlled by means of the parameter RDI\_reported. The default shall be RDI\_Reported = false.

NOTE 1: dUNEQ, dTIM, dDEG and dRDI are cleared during an aSSF/aTSF condition. Refer to subclauses 8.2.1.2 to 8.2.1.5.

NOTE 2: The detection of an unequipped VC signal is possible in a termination supervisory sink function despite both the supervisory-unequipped VC signal and the unequipped VC signal have signal label code "0". A trace identifier mismatch will be detected with the accepted trace identifier being all-ZEROS. This combination is the signature of the reception of an unequipped VC.

NOTE 3: Refer to subclause 8.5 for a MON description.

### 8.2.3.3 Adaptation sink function

cPLM	←	dPLM and (not aTSF).
cAIS	←	dAIS and (not aTSF) and (not dPLM) and AIS_Reported.
cLOA	←	dLOA and (not dAIS) and (not dPLM).

It shall be an option to report AIS as a fault cause. This is controlled by means of the parameter AIS\_reported. The default shall be AIS\_Reported = false.

NOTE 1: dLOA represents dLOF, dLOP or dLOM, whichever is applicable.

NOTE 2: The specification of the Pointer Interpreter algorithm is such that either dAIS or dLOP can be declared, not both at the same time. Refer to annex B.

### 8.2.3.4 Connection function

cFOP	←	dFOP and (not aSSF).
------	---	----------------------

## 8.2.4 Performance monitoring filter f11 (pN\_EBC)

Every second, the number of errored near-end blocks (N\_Bs) within that second is counted as the Near-end Error Block Count (pN\_EBC).

A "Near-end Block" (N\_B) is errored if one or more EDC violations (parity, CRC or line code violations) are detected.

For backward compatibility the specification is as follows: every second, the number of EDCVs is counted and "translated" into the pN\_EBC according to annex 3 of ITU-T Recommendation G.826 [17].

**Table 9: Performance monitoring in atomic functions**

Termination sink	Adaptation sink	Connection	Adaptation source
pN_EBC	pOFS	pPSC	pPJE
pF_EBC			
pN_DS			
pF_DS			

## 8.2.5 Performance monitoring filter f12 (pN\_DS)

Every second with at least one occurrence of aTSF (i.e. aSSF, dAIS, dTIM, or dUNEQ) or dEQ shall be indicated as a Near-end Defect Second (pN\_DS).

$$pN\_DS \leftarrow aTSF \text{ or } dEQ.$$

## 8.2.6 Performance monitoring filter f21 (pF\_EBC)

Every second, the number of errored far-end blocks (F\_Bs) within that second is counted as the pF\_EBC (Far-end Error Block Count).

A "Far-end Block" (F\_B) is errored if the REI count indicates one or more errors.

For backward compatibility the specification is as follows: every second, the number of errors conveyed back via REI is counted and "translated" into the pF\_EBC according to annex 3 of ITU-T Recommendation G.826 [17].

## 8.2.7 Performance monitoring filter f22 (pF\_DS)

Every second with at least one occurrence of dRDI shall be indicated as a Far-end Defect Second (pF\_DS).

$$pF\_DS \leftarrow dRDI.$$

## 8.2.8 Other performance monitoring parameters (pOFS, pPSC, pPJE)

Refer to the specific atomic functions.

## 8.3 Equipment management function fault management process

NOTE: ETSI TC TMN are currently developing an EN which addresses generically SDH management. Once the present document is produced, it is intended to align this subclause with the approved EN.

The equipment management function within the network element performs a persistency check on the fault causes before it declares a fault cause a failure. The fault causes are generated by the atomic function fault management process (subclause 8.2).

The failure is reported via the agent process (output failure report) and by means of alarms (audible and visible indicators). Typically, alarms can be divided into unit level alarms, NE level alarms and station alarms.

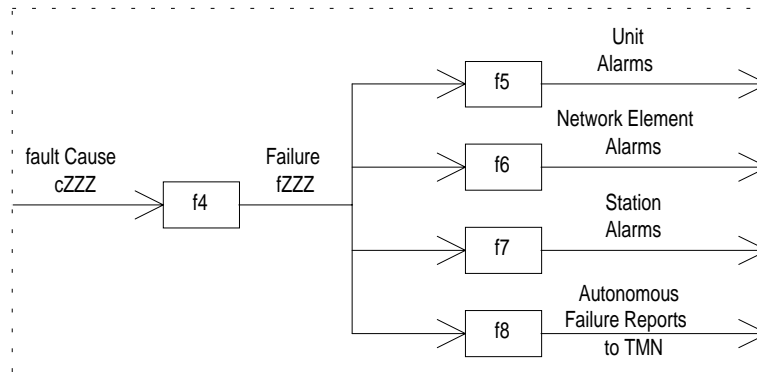

Figure 43: Fault management inside EMF function

Filter	Function
f4	integration of fault causes into failures
f5	translation of failures into Unit alarms
f6	translation of failures into Network Element alarms (e.g. severity)
f7	translation of failures into station alarms & alarm disconnect control
f8	fault management selective reporting control (OSI management)

### 8.3.1 Failure filter f4

A transmission failure shall be declared if the fault cause persists continuously for X seconds. The failure shall be cleared if the fault cause is absent continuously for Y seconds. X and Y shall be programmable between 100 ms and 30 s in steps of Z ms. The incremental value Z shall follow a logarithmic scale. The default values for X and Y shall be: X is 2,5 s  $\pm$  0,5 s and Y is 10 s  $\pm$  0,5 s.

A generic list of failures is shown in table 10.

Table 10: Failures declared per atomic function

Termination sink	Adaptation sink	Connection	Termination source
fSSF	fLOF	fFOP	fTF
fUNEQ	fLOM		fTD
fTIM	fLOP		
fDEG	fAIS		
fLOS	fPLM		
fRDI			

### 8.3.2 Replaceable unit alarm filter f5

Unit LEDs and other indicators are for further study.

### 8.3.3 Network element alarm filter f6

Severity indicators (prompt, deferred, info, etc.) are for further study.

### 8.3.4 Station alarm filter f7

Alarm types, severity's, etc. are for further study.

### 8.3.5 Failure report filter f8

For further study.

## 8.4 Equipment Management Function (EMF) performance monitoring process

NOTE: ETSI TC TMN are currently developing an EN which addresses generically SDH management. Once the present document is produced, it is intended to align this subclause with the approved EN.

The EMF performance monitoring process collects the event counts associated with:

- the trail performance parameters ES, SES, Background Block Error (BBE) and Unavailable Time (UAT) / Unavailable Second (UAS);
- the link performance parameters Out of Frame Second (OFS) and Pointer Justification Event (PJE);
- the protection performance parameter, Protection Switch Count (PSC).

It processes the event counts to derive the performance parameters, and stores these parameters in registers.

Such information can be used to sectionalise faults and to locate sources of intermittent errors, and/or determine the quality of the service.

The event counts (pZZZ) are generated by the atomic function performance monitoring process (subclause 8.2). They are the input signals to the filters f13, f14, f16, f23, f24 and f26 (figure 44). These filters determine if a second is an ES or a SES, and determine the number of BBEs per second. Filters f15 and f25 determine the Unavailable Time (UAT) periods.

Filter f31 stores the number of ESs, SESs and BBEs during available time, per 15 minute and 24 hour periods. In addition, it may store the number of Unavailable Seconds (UASs) in the same periods, and it may perform a threshold crossing check on the parameter counts.

To determine the quality of service, the network manager may calculate the Errored Seconds Ratio (ESR), Severely Errored Seconds Ratio (SESR) and the Background Block Error Ratio (BBER). Refer to ITU-T Recommendation G.826 [17].

Filter	Function
f13	Near-end errored second determination process
f14	Near-end severely errored second determination process
f15	Near-end unavailable time determination process
f16	Near-end EBC determination process
f23	Far-end errored second determination process
f24	Far-end severely errored second determination process
f25	Far-end unavailable time determination process
f26	Far-end EBC determination process
f31	performance monitoring history process
f32	performance monitoring selective reporting control (OSI management)

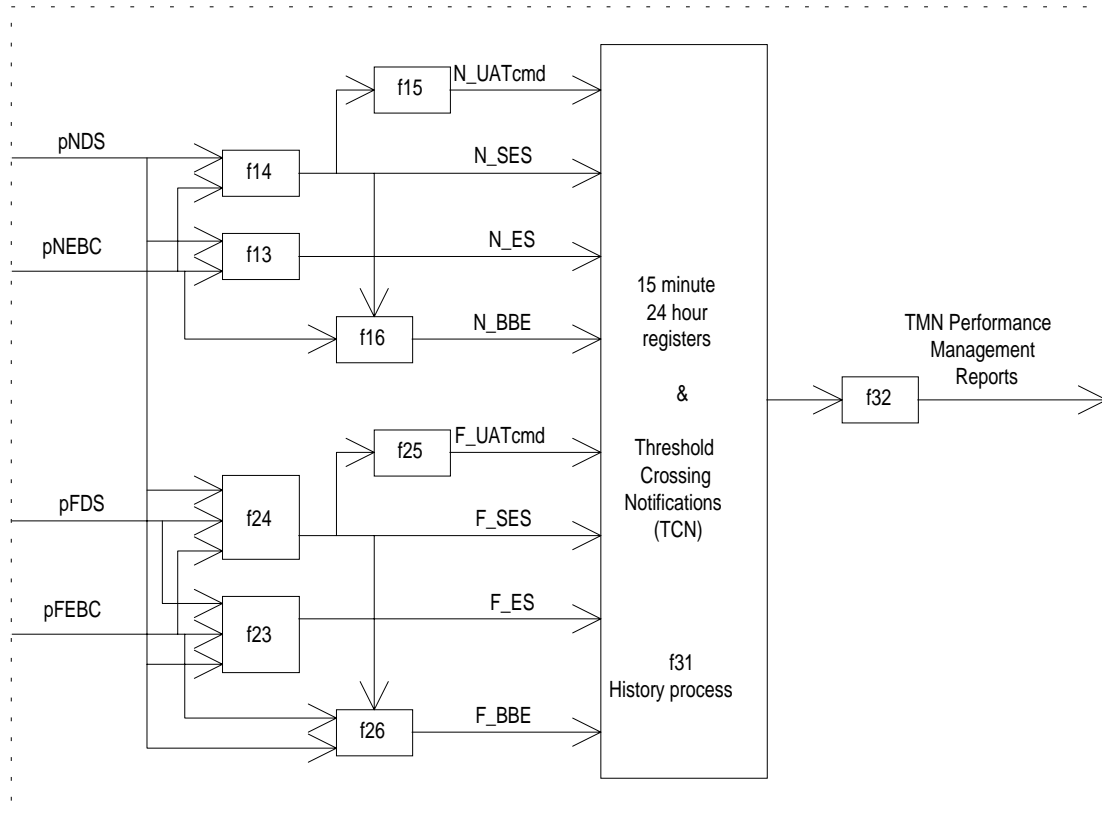

**Figure 44: Performance monitoring within equipment management function**

#### 8.4.1 PM filter f13 (N\_ES)

A Near-end Errored Second (N\_ES) shall be generated if pN\_DS is set or if pN\_EBC  $\geq 1$ ; i.e.:

$$N\_ES \leftarrow (pN\_DS = \text{true}) \text{ or } (pN\_EBC \geq 1).$$

#### 8.4.2 PM filter f23 (F\_ES)

A Far-end Errored Second (F\_ES) shall be generated if pF\_DS is set or if pF\_EBC  $\geq 1$ , and if that second is not a Near-end Defect Second (pN\_DS); i.e.:

$$F\_ES \leftarrow (pN\_DS = \text{false}) \text{ and } ((pF\_DS = \text{true}) \text{ or } (pF\_EBC \geq 1)).$$

#### 8.4.3 PM filter f14 (N\_SES)

A Near-end Severely Errored Second (N\_SES) shall be generated if pN\_DS is set or if pN\_EBC  $\geq N\_SESTHR$  (Near-end SES Threshold); i.e.:

$$N\_SES \leftarrow (pN\_DS = \text{true}) \text{ or } (pN\_EBC \geq N\_SESTHR).$$

N\_SESTHR shall be provisionable by the network manager within a range specified in the description of the atomic function.



#### 8.4.4 PM filter f24 (F\_SES)

A Far-end Severely Errored Second (F\_SES) shall be generated if pF\_DS is set or if pF\_EBC  $\geq$  F\_SESTHR (Far-end SES Threshold), and that second is not a Near-end Defect Second; i.e.:

$$F\_SES \leftarrow (pN\_DS = \text{false}) \text{ and } ((pF\_DS = \text{true}) \text{ or } (pF\_EBC \geq F\_SESTHR)).$$

F\_SESTHR shall be provisionable by the network manager within a range specified in the description of the atomic function.

#### 8.4.5 PM filter f15 (N\_UAT\_cmd)

Near-end Unavailable Time command (N\_UAT\_cmd) shall be set if ten consecutive N\_SESs are detected. N\_UAT\_cmd shall be cleared after ten contiguous seconds not being N\_SES.

#### 8.4.6 PM filter f25 (F\_UAT\_cmd)

Far-end Unavailable Time command (F\_UAT\_cmd) shall be set if ten consecutive F\_SESs are detected. F\_UAT\_cmd shall be cleared after ten contiguous seconds not being F\_SES.

#### 8.4.7 PM filter f16 (N\_BBE)

N\_BBE shall equal pN\_EBC if the N\_SES of that second is not set. Otherwise, N\_BBE shall be zero.

#### 8.4.8 PM filter f26 (F\_BBE)

F\_BBE shall equal pF\_EBC if the F\_SES of that second is not set and if that second is not a Near-end Defect Second. Otherwise, F\_BBE is zero.

#### 8.4.9 PM filter f31 (history management)

An outline of the history management process is given below. The full specification will be developed by ETSI TC TMN. The description below is based on "unidirectional unavailable time" processing. For the case of "bi-directional unavailable time" processing, the specification is for further study.

Unavailable Time (UAT) shall be the period starting 10 seconds before the UAT\_cmd is set and shall terminate 10 seconds before the UAT\_cmd is cleared. The seconds in UAT are the Unavailable Seconds (UAS).

NOTE 1: By delaying the "PM time of day" by 10 seconds with respect to the actual "time of day", UAT starts and ends at the activation and deactivation of UATcmd (refer to annex F).

The ES, SES, UAS and BBEs shall be presented per period of 15 minutes and 24 hours (15 minute register, 24 hour register):

- the UAS registers contain the number of unavailable seconds;
- the ES registers contain the number of errored seconds during available time;
- the SES registers contain the number of severely errored seconds during available time;
- the BBE registers contain the number of errored blocks during available time which are not SES.

Each of the ES, SES and BBE registers shall have a, provisionable, threshold assigned to it. When this threshold is reached or crossed ( $\geq$ ), a notification shall be send to the OS. This notification is called the Threshold Crossing Notification (TCN).

NOTE 2: This terminology follows ITU-T Recommendation G.784 [25]. In ITU-T Recommendation M.2120, subclause 2.3 [23], this is called Threshold Report (TR).

A TCN clear message may optionally be generated for 15 minute registers if the clear threshold ( $\text{Thr}_{\text{Clr}}$ ) is not reached (<) at the end of the 15 minutes. This may be done only during available time. M.2120 specifies  $\text{Thr}_{\text{Clr,SES}} = 0$  while  $\text{Thr}_{\text{Clr,ES}}$  is programmable.

NOTE 3: Subclause 2.3 of CCITT Recommendation M.2120 [24] allows for two options: (a) generate TCNs (TRs) for every period in which the threshold is exceeded, or (b) generate no more than one TCN until a period contains less (S)ES events than the clear threshold and a TCN-clear (RTR) is generated.

Limited historical data shall be logged. For each of the registers the following shall be provided:

- current 15 minute register and a current 24 hour register;
- at least 16 recent 15 minute registers and one recent 24 hour register.

The recent 15 minute register may contain non-zero counts only.

NOTE 4: A visual representation of the history management processes is presented in annex F.

## 8.5 Trail termination point mode and port mode

To prevent alarms being raised and failures being reported during trail provisioning actions trail termination functions shall have the ability to enable and disable fault cause declaration. This shall be controlled via their termination point mode and port mode parameter.

The termination point mode (see figure 45) shall be either "monitored" (MON) or "not monitored" (NMON). The state shall be MON if the termination function is part of a trail and provides service, and NMON if the termination function is not part of a trail or is part of a trail which is in the process of set-up, break-down or re-arrangement.

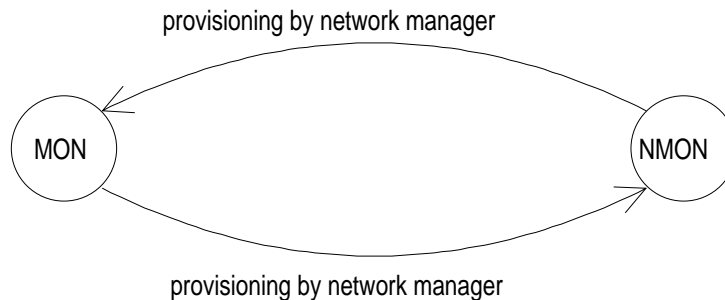

**Figure 45: Trail termination point modes**

In physical section layers, the termination point mode is called the port mode. It has three modes (figure 46): MON, AUTO and NMON. The AUTO mode is like the NMON mode with one exception: if the LOS defect clears, the port mode is automatically changed into MON. This allows for alarm free installation without the burden of using a management system to change the monitor mode.

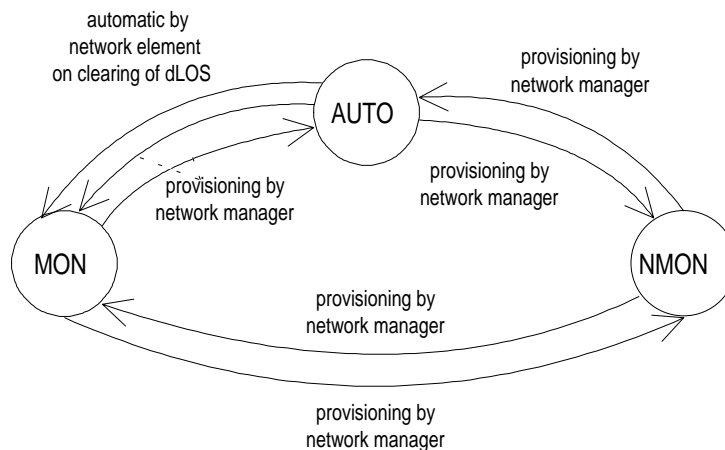

**Figure 46: Port modes**

---

## 9 Protection process

### 9.1 Introduction

NOTE: Three documents are under preparation which generically address protection switching. When the study has been completed and the documents approved and published, it is intended to align this subclause with them. Therefore, the contents of this subclause reflect the current situation in ITU-T Recommendations and may be subjected to future modification.

The protection process is based on the philosophy underlying the functional model of ITU-T Recommendation G.803 [6]:

- subclause 9.2 introduces general characteristic parameters of protection;
- subclause 9.3 specifies functional models of trail protection types;
- subclause 9.4 specifies functional models of sub-network connection types;
- subclause 9.5 specifies equipment protection.

Care should be taken when reading this section not to confuse the terms "sub-layer" and "sub-network".

### 9.2 General

A protection application makes use of pre-assigned capacity between nodes. The simplest architecture has 1 working and 1 protection capacity (1+1), the most complex architecture has n working and m protection capacities (m:n).

A restoration application makes use of any capacity available between nodes. In general the algorithms used for restoration will involve re-routeing. When restoration is used, some percentage of the transport network capacity will be reserved for re-routeing working traffic. Restoration is initiated by the network operator and as such does not fall within the scope of the present document.

Several types of protection can be distinguished. They are categorized into two classes: trail and SNC protection:

**Trail protection:** a defect condition in a layer initiates reconfiguration switching in the same layer. The following trail protection types are recognized:

- linear trail protection;
- Shared Protection RING (SPRING) protection;
- Dedicated Protection RING (DPRING) protection.

Trail protection is characterized by the expansion of the trail termination function into a new sub-layer (see subclause 5.4) known as the protection sub-layer.

**Sub-Network Connection (SNC) protection:** a defect condition in a layer initiates reconfiguration switching in the client layer. The following SNC protection types can be recognized:

- Inherently monitored Sub-Network Connection (SNC/I) protection;
- Non-intrusively monitored Sub-Network Connection (SNC/N) protection;
- tandem connection protection is for further study.

The protection types are characterized by the following parameters:

- protection architecture (1+1, 1:n, m:n);
- switching type (single-ended, dual-ended);
- Automatic Protection Switch (APS) channel (provisioning, usage, coding);
- operation type (non-revertive, revertive);
- protection switch requests;
- protection switch performance;
- protection switch state machine.

## 9.2.1 Protection architectures

Protection processes are allocated to the Connection functions (C) in each layer and to the sub-layer Protection Connection functions (P\_C) in the expanded trail termination. Connection functions implement SNC protection, protection connection functions implement trail protection.

The NE at the source end of the protection span transmits the protected group as a protection group. The NE at the sink end of the protection span outputs the received protection group as the protected group. In case no defects are detected in the working SNC/trail signals, these signals are selected as the normal signals. The protection SNCs/trails may in this case transport extra traffic.

The SNCs/trails selected by the sink end are called the active SNCs/trails. The others are called the standby SNCs/trails.

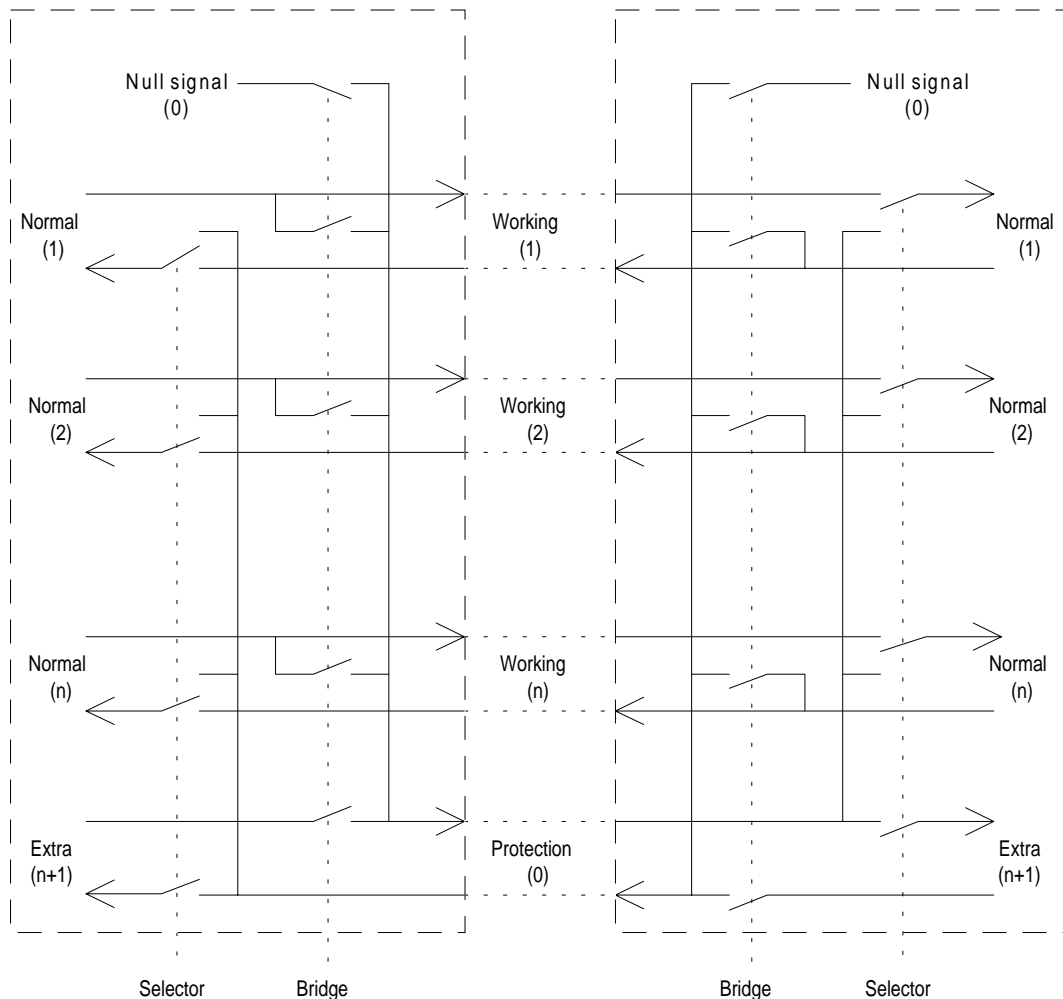
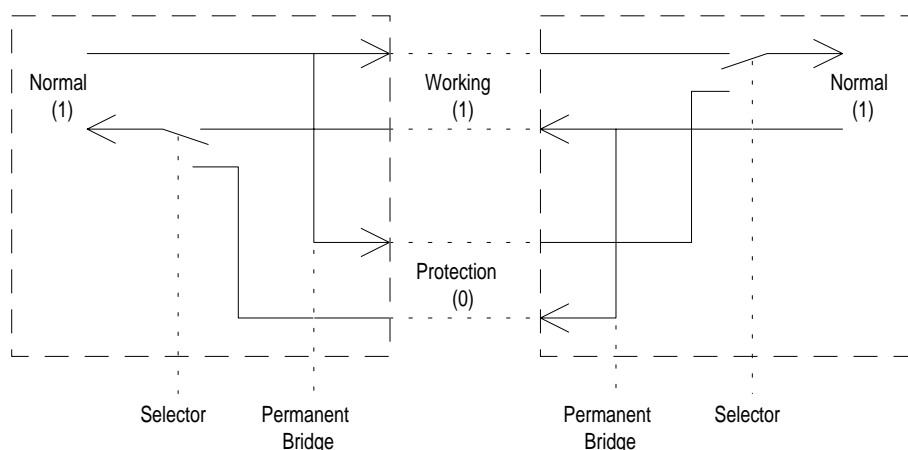

**Figure 47: 1:n protection architecture**

A 1:n protection architecture (figure 47) has  $n$  normal traffic signals,  $n$  working SNCs/trails and 1 protection SNC/trail. It may have 1 extra signal.

The signals on the working SNCs/trails are the normal traffic signals.

The signal on the protection SNC/trail may either be one of the normal traffic signals, an extra traffic signal, or the null signal (e.g. an all-ONEs signal, a test signal, one of the normal traffic signals). At the source end, one of these signals is connected to the protection SNC/trail. At the sink end, the signals from the working SNCs/trails are selected as the normal signals. When a defect condition is detected on a working SNC/trail or under the influence of certain external commands, the transported signal is bridged to the protection SNC/trail. At the sink end, the signal from this protection SNC/trail is then selected instead.



**Figure 48: 1+1 protection architecture**

A 1+1 protection architecture (figure 48) has one normal traffic signal, one working SNC/trail, one protection SNC/trail and a permanent bridge.

At the source end, the normal traffic signal is permanently bridged to both the working and protection SNC/trail. At the sink end, the normal traffic signal is selected from the better of the two SNCs/trails.

Due to the permanent bridging, the 1+1 architecture does not allow an extra unprotected traffic signal to be provided.

An  $m:n$  protection architecture has  $n$  normal traffic signals,  $n$  working SNCs/trails and  $m$  protection SNCs/trails. The signals on the working SNCs/trails are the normal traffic signals. The signal on a protection SNC/trail is either one of the normal traffic signals, an extra traffic signal, or a null signal. At the source end, any of the signals mentioned can be connected to the protection SNCs/trails. At the sink end, the signals from the working SNCs/trails are selected as the normal traffic signals. In case of a defect condition on a working SNC/trail, the transported signal is routed over one of the protection SNCs/trails. At the sink end, the signal from this protection SNC/trail is then selected instead.

## 9.2.2 Switching types

Single ended or dual-ended switching is possible.

In **single-ended** switching, the switching is complete when the traffic signal (service) is selected from standby at the end detecting the fault. The sink end transfers the traffic signal (service) without communication with the source end.

In **dual-ended** switching, the traffic signal (service) is switched from the active to the standby SNC/trail at both ends of the protection span.

Dual-ended switching requires a communications channel between the two ends of the protection SNC/trail; this is called the Automatic Protection Switching (APS) channel. The APS channel is terminated in the connection functions.

Under dual-ended switching protocols, switching at only one end is not allowed. The two ends communicate to initiate transfer of the traffic signal (service). If the priority of the request of the source end is lower than that of the sink end or does not exist, the sink end initiates transfer of the traffic signal (service) and the source end does follow this transfer.

### 9.2.2.1 APS channel provisioning

The APS channel is protection application specific.

**EXAMPLE:** For multiplex section protection the APS channel is in the K1K2 bytes. Refer to MSP\_C function.

### 9.2.2.2 APS channel usage

The use of the APS channel is protection application specific.

### 9.2.2.3 APS channel coding

The APS channel coding is protection application specific, and is specified in the associated atomic (protection\_)connection function.

NOTE: All application specific codings could be based on a generic (superset) coding scheme. This is for further study.

### 9.2.3 Operation types

Revertive or non-revertive operation is possible.

In **revertive** operation, the traffic signal (service) always returns to (or remains on) the working SNC/trail if the switch requests are terminated. I.e. when the working SNC/trail has recovered from the defect or the external request is cleared.

In **non-revertive** operation, the traffic signal (service) does not return to the working SNC/trail if the switch requests are terminated.

### 9.2.4 Protection switch requests

Automatic protection switching is based on the defect conditions of the working and protection SNCs/trails. These defect conditions result in the generation of Signal Fail (SF) and signal degrade (SD) signals (refer to supervisory process, subclauses 8.2.2.4, 8.2.2.5 and 8.2.2.6).

Protection switch requests can be differentiated by their origin:

- near-end:
  - SF and SD conditions;
  - external requests: Clear, Lockout, Forced Switch, Manual Switch and Exercise;
  - state: Wait-To-Restore, Do Not Revert, No request and Reverse Request;
- far-end:
  - SF and SD conditions;
  - external requests: Lockout, Forced Switch, Manual Switch and Exercise;
  - state: Wait-To-Restore, Do Not Revert, No request and Reverse Request.

The Clear, Lockout, Freeze, Forced Switch #i, Manual Switch #i, Exercise, and other requests are for further study.

### 9.2.5 Protection switch performance

One of the characteristics of protection is that switching times are relatively fast compared to restoration.

Protection switching shall be completed within the switch-over time X of reception of a SF or SD signal that initiates a switch. The value of X depends on the protection type and the network layer that it applies to and is specified in the atomic functions (e.g. for multiplex section protection X is 50 ms).

The service interruption due to the switching on an external request shall be limited to the switch-over time X.

### 9.2.6 Protection switch state machine

The protection switch state machine (algorithm) is protection application specific, and is specified in the associated atomic (protection\_) connection function.

NOTE: All application specific codings could be based on a generic (superset) state machine. This is for further study.

## 9.2.7 Protection connection function (I/O and processes)

A connection function which performs a protection function has the following inputs and outputs and internal processes (see figure 49):

- Data (D), Clock (CK), Frame Start (FS), Signal Fail (SF) and Signal Degrade (SD) per Working / Protection input signal. For the case of dual-ended switching, at least one APS signal per protection group;
- D, CK, FS and SF per Normal / Extra output signal;
- D, CK, FS and SF per Working / Protection output signal. For the case of dual-ended switching, at least one APS signal per protection group;
- D, CK, and FS per Normal / Extra input signal;
- connection matrix and unequipped VC generation processes;
- APS channel processor process;
- control process.

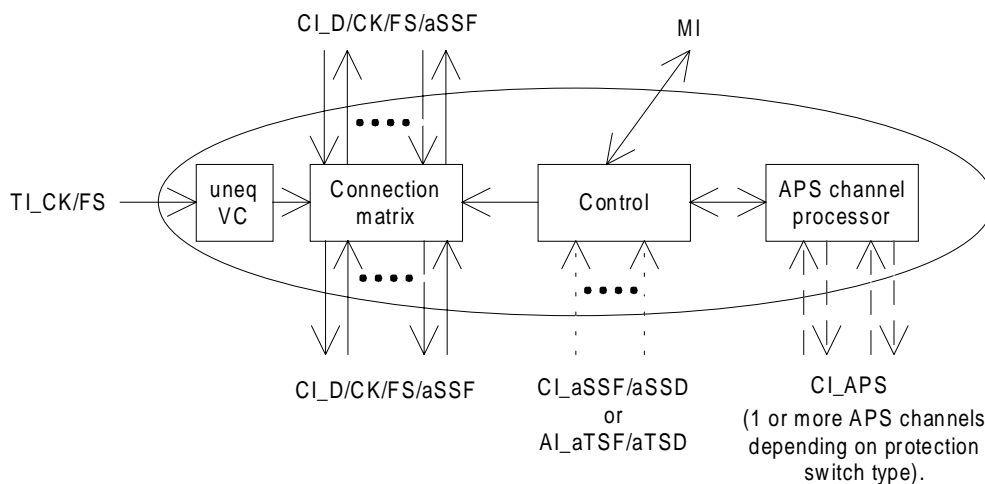

**Figure 49: Possible processes within a connection function**

## 9.3 Trail protection class

### 9.3.1 Linear trail protection

Generically, linear trail protection protects against:

- a) server failures;
- b) disconnected matrix connections (via unequipped signal detection);
- c) an excessive number of bit errors (via e.g. error detection code violation supervision); and
- d) mis-connections (via trace identifier mismatch monitoring).

Server failures are detected by the client layer trail termination function as the AIS defect condition (i.e. MSdAIS). For the case where a trail termination does not detect AIS, the server failure is reported by the server via its SSF signal.

**NOTE:** Trail protection does not protect against mis-compositions of payload (via signal label mismatch monitoring). The adaptation function is outside the protection span (see figure 50).



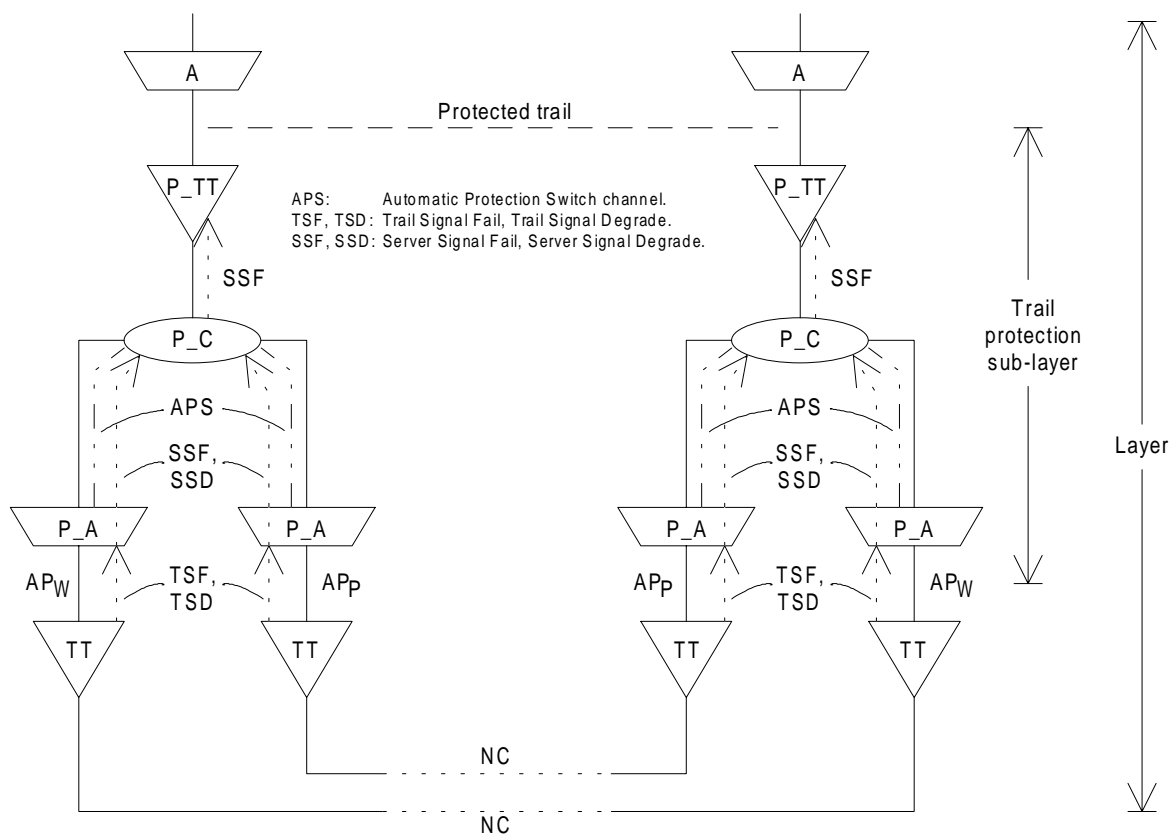

**Figure 50: Generic trail protection model (1+1 protection)**

Within a layer, the Trail Termination functions (TT) terminate the layer's trail overhead and the Adaptation functions (A) adapt the signal in the layer to its client layer. The additional (protection sub-layer) functions P\_A, P\_C and P\_TT describe the trail protection process.

The P\_A provides access to the layer's APS channel (i.e. the layer's protection communication channel) which is, together with the data signal and the trail signal fail status (as SSF signal), forwarded to the layer's Protection Connection (P\_C) function.

The APS is terminated in the P\_C, while the selected data signal and its SSF are output.

The P\_TT sink passes the received data signal and reports its status (loss of trail, or otherwise) as indicated by the SSF signal.

**EXAMPLE:** An example of a protected trail is the protected multiplex section trail (i.e. MSP).

### 9.3.2 SPRING protection

Figure 51 shows the MS SPRING protection. The dashed lines show the connections in the case of a protection switch (defect) condition in the West and the East SNCs.

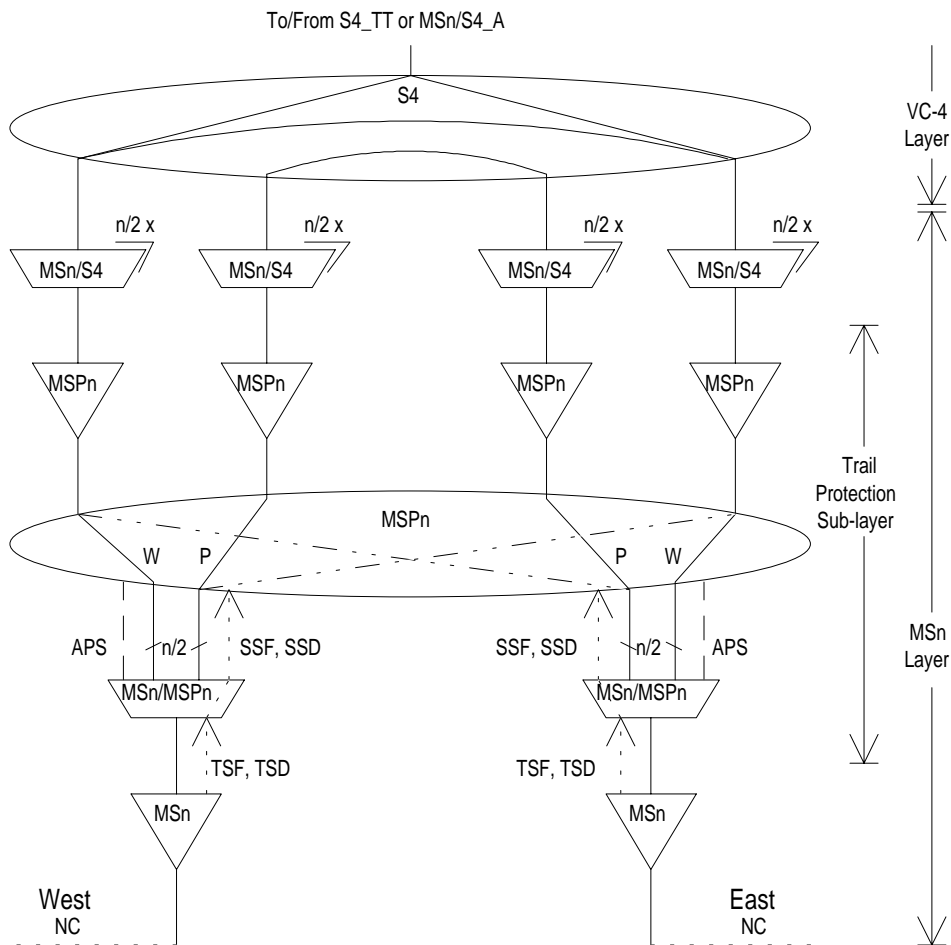

**Figure 51: Multiplex section shared protection ring (without protection access, dash-dot-dash lines in MSPn\_C show protection routing)**

Multiplex section shared protection rings are characterized by dividing the total payload per multiplex section equally into working and protection capacity, e.g. for MS-N SPRING there are  $N/2$  Administrative Unit Groups (AUGs) available for working and  $N/2$  AUGs for protection.

The notation of "sharing" refers to the fact that the ring protection capacity can be shared by any multiplex section of a multinode ring under a section or node fault condition. Sharing of protection capacity may lead to improved traffic carrying capacity under normal conditions over other ring protection types.

Under non-fault conditions, the protection capacity can be used to carry extra (low priority) traffic. This is shown in figure 52 by means of the dash-dot-dash lines and atomic functions.

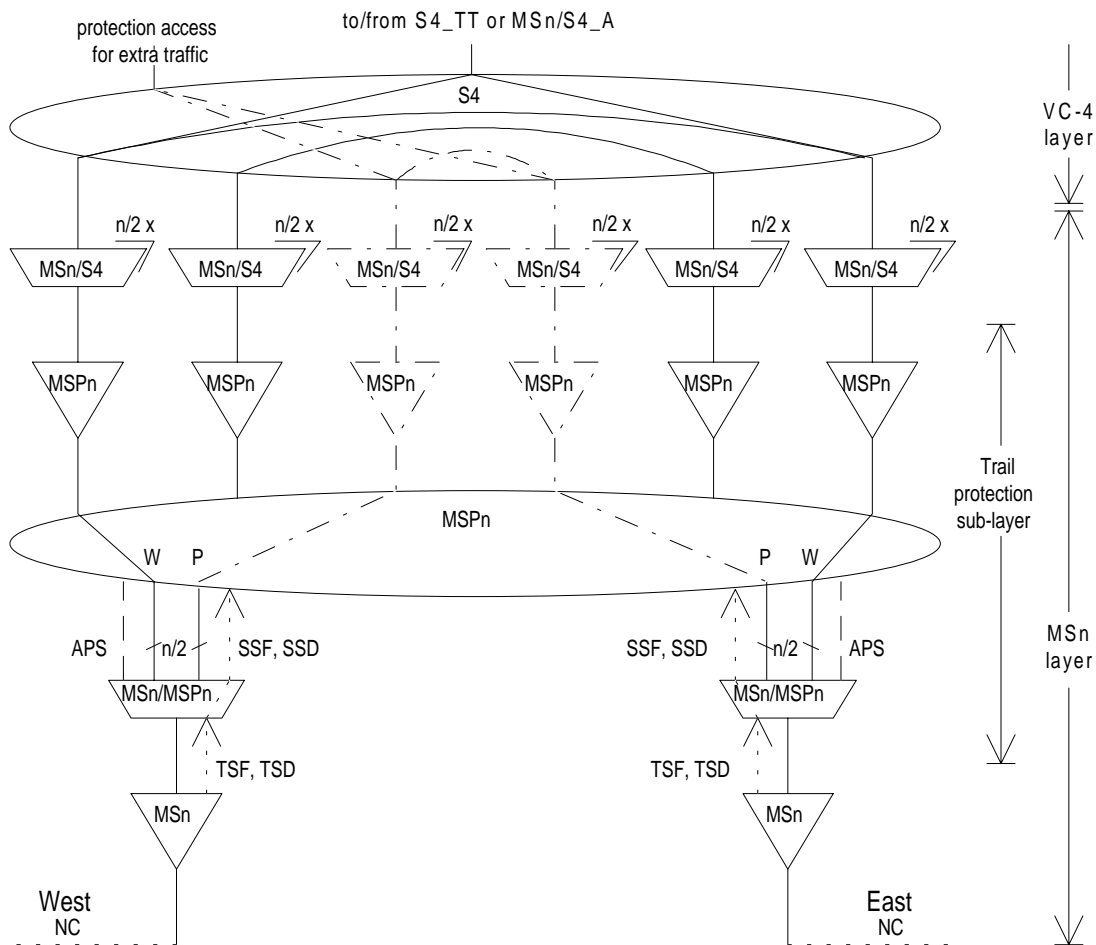
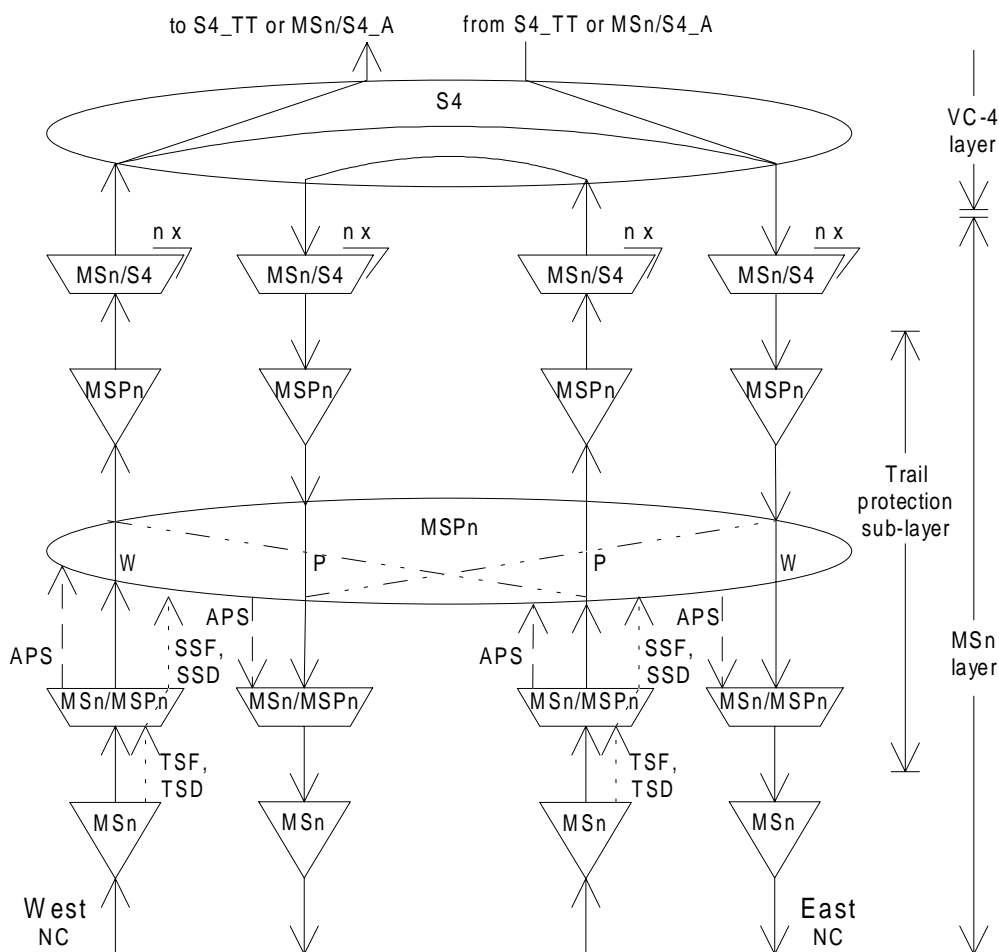

Figure 52: Multiplex section shared protection ring (with protection access for extra traffic)

### 9.3.3 DPRING protection

Figure 53 shows the MS DPRING protection. The dash-dot-dash lines in the MSP\_C show the connections in case of a protection switch condition in the West and the East SNCs.



**Figure 53: Multiplex section dedicated protection ring  
(dash-dot-dash lines in MSPn\_C show protection routing)**

Multiplex section dedicated protection rings are characterized by a 1:1 protection scheme. This scheme is based on unidirectional transmission.

Under defect conditions, all the AUGs are looped to the protection channel. MS dedicated ring protection is based on the detection of defects by the MSn\_TT functions in the SDH NEs. The operation of this type of ring is always dual-ended.

NOTE: The access for extra traffic is for further study.

## 9.4 SNC protection class

### 9.4.1 Inherently monitored SNC (SNC/I) protection

SNC/I protection, generically, protects against server failures. The protection process and the defect detection process are performed by two adjacent layers. The server layer performs the defect detection process, and forwards the status to the client layer by means of the Server Signal Fail (SSF) signal.

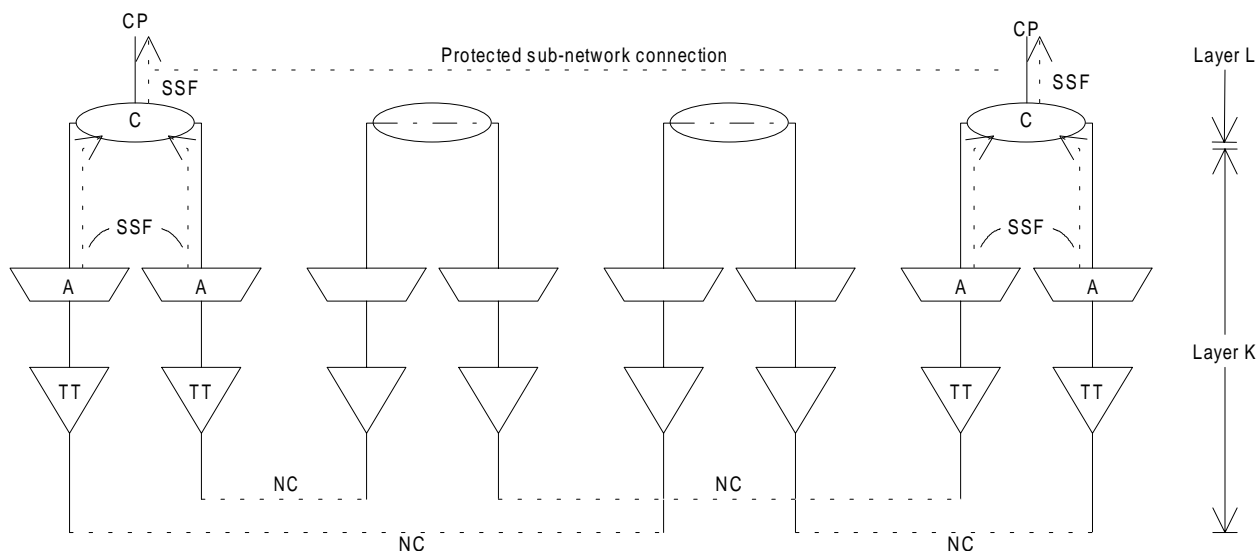

**Figure 54: SNC/I protection model**

In layer K, the Trail Termination functions (TT) terminate the layer K trail overhead. The adaptation functions (A) adapt the signal in layer K to layer L, and forward both the data and the Server Signal Fail (SSF) status signals to the layer L connection functions (C). These connection functions output the selected data signal and its SSF status signal.

**NOTE 1:** The connection functions in layer L perform two processes: routing and protection. Routing is a complex process on many inputs and outputs, but the response on a routing modification request may be "slow". Protection is a simple process on two inputs and one output, but the response on a protection switch request needs to be "fast".

SNC/I protection with dual-ended switching is for further study.

An example of an inherently monitored protected Sub-Network Connection is the protected VC-12 connection in a VC-12 Ring network. The detection of LOP (TU12dLOP) or AIS (TU12dAIS) (see note) in the VC-4 to VC-12 Adaptation Sink function results in the declaration of a VC-12 Server Signal Fail. The VC-12 data and the SSF signal is forwarded to the VC-12 Connection (S12\_C) function. The S12\_C transmits the selected VC-12 and the associated SSF to its output. This output is either connected to a VC-12 trail termination sink function or to a VC-4 to VC-12 adaptation source function. In the latter case the signal is transported over another sub-network.

**NOTE 2:** The detection of this type of AIS represents the detection of any defect in:

- a) the optical / electrical section, regenerator section, multiplex section, VC-4 path layers and the VC-12 connection function in previous NEs; or
- b) the OS/ES, RS, MS, and the VC-4 trail termination function in this NE.

## 9.4.2 Non-intrusively monitored SNC (SNC/N) protection

SNC/N protection, generically, protects against:

- server failures;
- disconnected matrix connections (via unequipped signal detection);
- an excessive number of bit errors (via e.g. error detection code violation supervision);
- mis-connections (see note 1) (via trace Id mismatch supervision).

"Mis-compositions of payload" supervision (via signal label mismatch supervision) is not performed (see note 2). Server failures are detected by the server layer and reported via the SSF signal.

SNC/N performs protection on the same characteristics as used with trail protection, but does it on a "segment (intermediate part) of the trail".

NOTE 1: Both the working and the protection SNC carry the same trail with the same trace identifier.

NOTE 2: In this SNC/N protection scheme both the working and the protection SNC carry the same trail. The payloads, and therefore the signal labels, are the same.

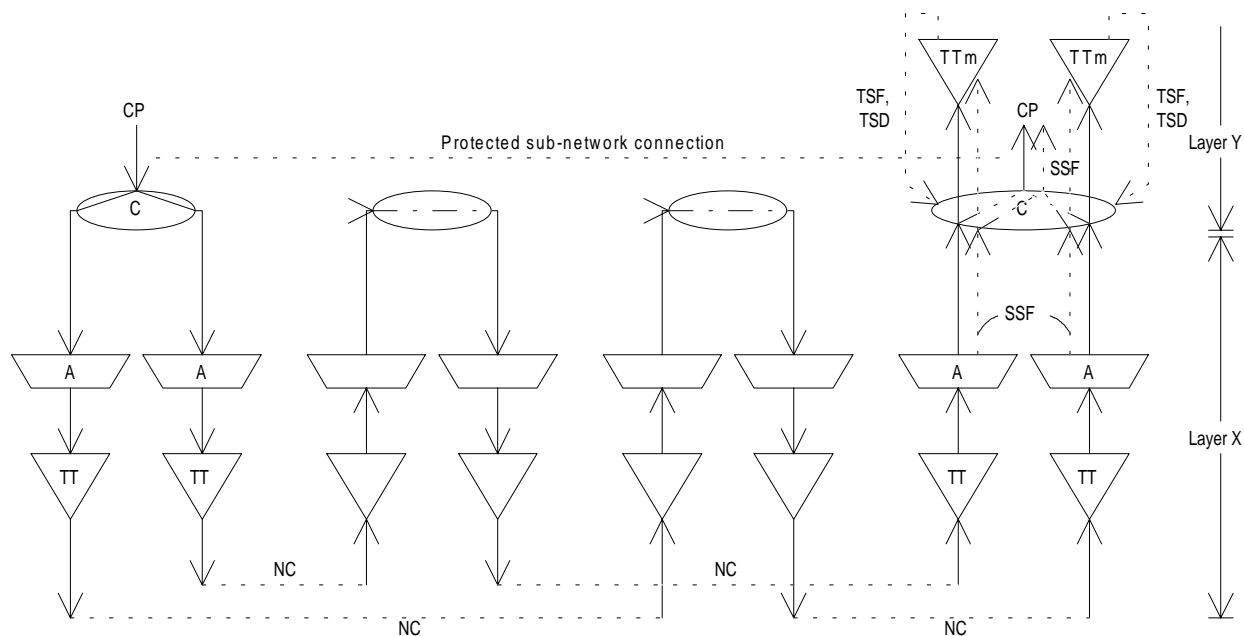

**Figure 55: 1+1 SNC/N protection model (one direction shown)**

The 1+1 SNC/N protection is shown in figure 55. The trail, which is originated elsewhere in the network, enters the protected Sub-Network at the top-left Connection Point (CP). The signal is broadcast (dual fed) over the working and protection sub-network connections. At the end of the subnetwork connection protection span the two signals are supervised for their integrity by the two trail termination functions. Trail signal fail and trail signal degrade conditions are conveyed back to the local connection function which selects between the working and protection signal. The selected signal is applied at the top-right Connection Point (CP) for further transport.

## 9.4.3 Tandem connection protection

For further study.

## 9.5 Equipment protection

For further study.

## 10 Timing processes

### 10.1 Introduction

Synchronization of NEs within the SDH network is required to prevent jitter / wander generation. The target is that the synchronization signal shall have as good a quality as necessary. In normal situations, the synchronization signal should be traceable to a Primary Reference Clock (PRC), compliant to ITU-T Recommendation G.811 [13]. Under fault conditions, NEs may be temporarily synchronized by signals traceable to clocks of lower quality (EN 300 462-5-1 [26] for SEC, and SSU for further study). The methods used for synchronization are described in EN 300 462-2-1 [5]. The number of nodes which can be connected in the trail is determined by the synchronization network reference chain in EN 300 462-2-1 [5].

The timing processes within a network element can be divided into five main categories:

- 1) collection of synchronization reference signals;
- 2) selection and processing of reference signal;
- 3) distribution of processed reference signal;
- 4) inter atomic function timing;
- 5) generation of AIS timing.

Subclauses 10.2 to 10.6 describe these five processes.

### 10.2 Synchronization timing collection

Figure 56 describes the synchronization time collection process. Two classes of synchronization reference inputs can be recognized:

- external synchronization reference inputs;
- internal synchronization reference inputs.

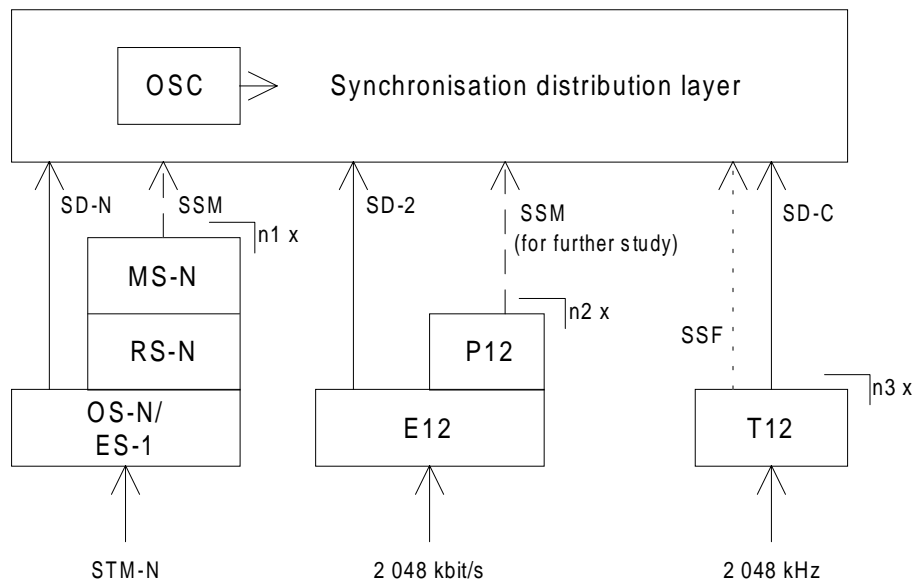

**Figure 56: Synchronization timing collection**

## 10.2.1 External synchronization reference inputs

The NE can derive its timing from one of a number of external sources (figure 56). The physical characteristics of these interfaces shall conform to the following:

- Optical STM-N interfaces (SD-N), shall conform to ITU-T Recommendation G.957 [11]. Electrical STM-1 interfaces shall conform to CCITT Recommendation G.703 [7], clause 12. The S1 byte within the MSOH of each STM-N shall be used to convey Synchronization Status Messages (SSM);
- 2 048 kbit/s interfaces (SD-2) shall conform to CCITT Recommendation G.703 [7], clause 6 and to the jitter and wander requirements as specified in subclause 11.3.2.3. It shall be possible to designate a 2 048 kbit/s interface as a synchronization source irrespective of whether the interface is carrying traffic or not. The case of a 2 048 kbit/s interface with a Synchronization Status Message is for further study;
- External 2 048 kHz synchronization interfaces (SD-C) shall conform to CCITT Recommendation G.703 [7], clause 10 and jitter and wander requirements as specified in subclause 11.3.2.3.

NOTE: The frequency and jitter / wander tolerance of these synchronization signals are constrained by the requirements of the client layer.

The number of selectable interfaces, both concerning the number of different types and the number of each type (n1, n2, n3 in figure 56) to be provided, is determined by the equipment functional specification of the NE.

## 10.2.2 Internal synchronization reference input

The NE shall also provide an internal oscillator which optionally could be selected as the NE timing signal.

## 10.3 Synchronization timing selection and processing

### 10.3.1 Synchronization reference source selection

Two selection processes are active in this SD layer. Selection of the reference signal to synchronize the system clock, and selection of the reference clock to forward to the synchronization reference output interface.

Each synchronization reference input signal has a quality level associated with it and is assigned a unique priority level. The selection process shall automatically select the synchronization source for the NE based on a selection algorithm which uses the defect status of the synchronization reference source signals, the quality indication indicated by the SSM of the synchronization reference source signals, and the priority list. It selects from the 'set of signals with the highest quality' the one with 'the highest priority'.

NOTE: Defect detection in the SDH section layers result in the generation of the all-ONEs (AIS) signal at the output of the atomic function which has detected the defect. The insertion of this all-ONEs signal is detected by the SSM process as the reception of a Quality Level 15 (QL15) condition; i.e. do not use this synchronization reference source signal. For that reason the MS-N layer is not required to forward a signal fail signal to the SD layer. The SSM signal contains sufficient information.

### 10.3.2 Clock processing

For further study.

NOTE: Two clock processing levels are recognized; the SEC level and the SSU level.



## 10.4 Synchronization timing distribution

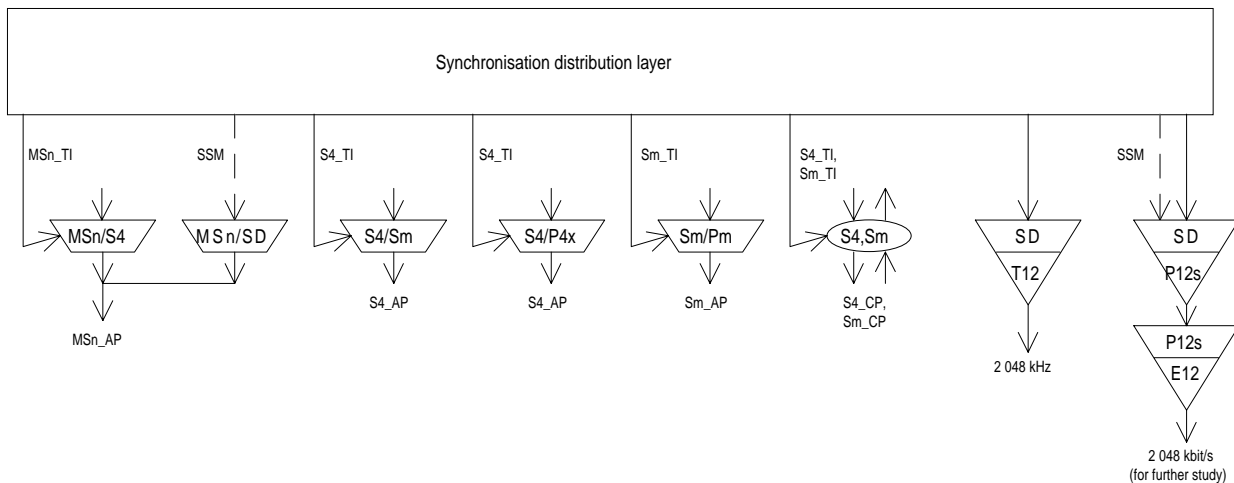

Figure 57: Synchronization timing distribution

### 10.4.1 Internal synchronization distribution interfaces

The synchronization timing reference generated in the synchronization distribution layer is distributed to the SDH adaptation source functions via the Timing Information (TI) signals (figure 57). These signals contain the Clock (TI\_CK) and Frame Start (TI\_FS) information. The elastic store processes in those adaptation source functions use these TI signals to read out the data. The SDH path layer connection functions use these signals to generate the unequipped VC signals.

### 10.4.2 Synchronization reference outputs

The NE may provide one or more external 2 048 kHz and/or 2 048 kbit/s synchronization output ports for use by external equipment, as determined by its Equipment Functional Specification. These interfaces shall conform to CCITT Recommendation G.703 [7], paragraph 10, paragraph 6, with jitter and wander requirements as specified in subclause 11.3.1.3.

A 2 048 kbit/s synchronization interface is for further study.

## 10.5 Inter atomic function timing

In a network element, three classes of clocks are present:

- the recovered clock signals;
- the locally generated clock signals;
- the smoothed clock signals.

The atomic functions (in the functional model) are timed as follows (see figure 58):

All sink functions are timed from the incoming clock (and frame start); i.e. every atomic sink function passes the timing information applied at its input to its output. Gaps may be added to the clock signal to accommodate the processing of overhead bytes. Adaptation sink functions which perform alignment (see note) (see figure 58c), output the extracted / recovered frame start from AI\_D (instead of the incoming frame start). Adaptation functions which perform smoothing (see figure 58d), output an equally spaced clock which may be derived after justification control processing from CI\_D.

NOTE: Frame alignment and pointer interpretation are two instances of "alignment".

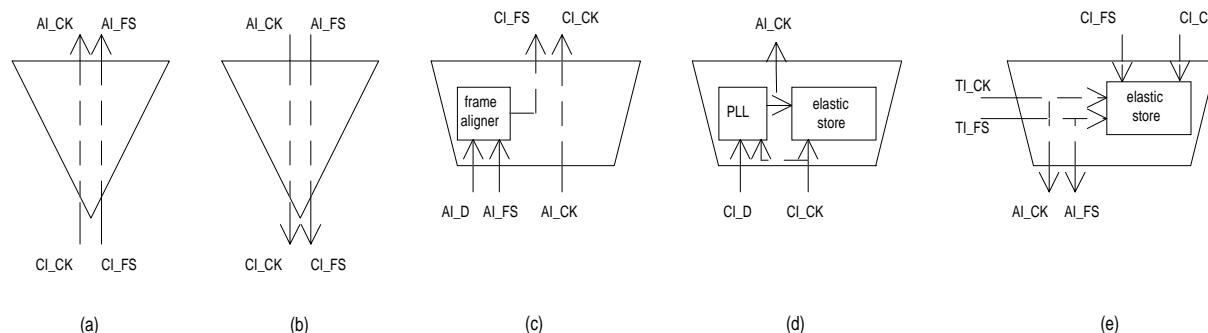

**Figure 58: Atomic function timing**

All SDH adaptation source functions, except those which byte-synchronously map PDH signals into SDH, receive an incoming clock at their connection point and the relevant timing information from the SD layer at their timing point. They output the timing information.

SDH to PDH, and PDH to PDH, adaptation sink functions smooth the incoming gapped clock to meet the jitter / wander requirement at the CCITT Recommendation G.703 [7] station interface.

All termination source functions are timed by the clock (and frame start) applied at their input (the access point).

The modelling of the PDH multiplex timing process is for further study. It has been proposed that an additional "timing" atomic function be added to the PDH path layers, which would generate the Px\_TI signals.

## 10.6 AIS timing

### Sink direction

All-ONES (AIS) insertion in the sink direction replaces the data signal by a local generated all-ONES signal. The clock signal which generates this all-ONES data signal can be the clock signal applied at the input of the atomic function; i.e. the CI\_Sk\_CK or AI\_Sk\_CK clock signal.

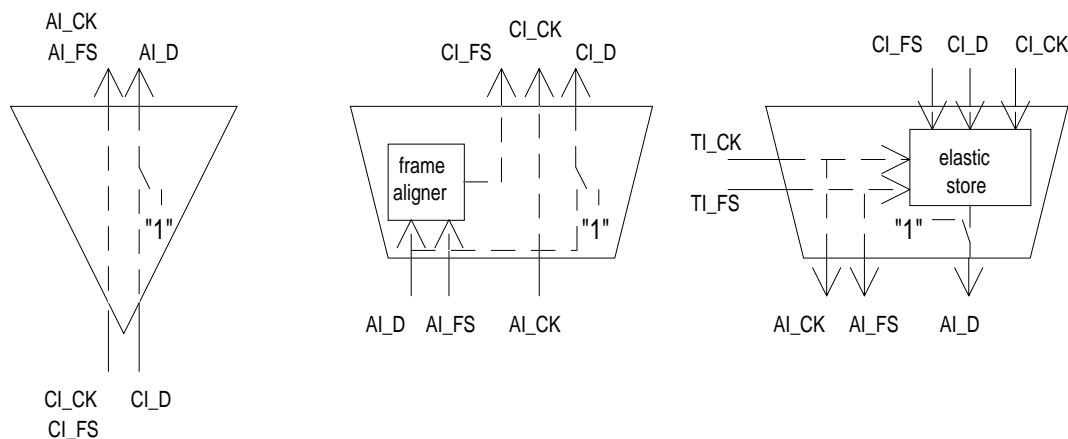

**Figure 59: AIS timing**

## Source direction

All-ONEs (AIS) insertion in the source direction replaces the data signal by an all-ONEs signal. This all-ONEs signal is generated by a local clock, which is:

- the S4\_TL\_CK for the case of AU4-AIS;
- the Sm\_TL\_CK for the case of TUm-AIS (m = 3,2,12,11);
- a  $\pm 20$  ppm accurate AIS oscillator, in the RSn/MSn\_A\_So function, for the case of MSn-AIS;
- a  $\pm 15$  ppm accurate AIS oscillator for the case of "140 Mbit/s-AIS";
- a  $\pm 20$  ppm accurate AIS oscillator for the case of "34 Mbit/s-AIS";
- a  $\pm 30$  ppm accurate AIS oscillator for the case of "8 Mbit/s-AIS";
- a  $\pm 50$  ppm accurate AIS oscillator for the case of "2 Mbit/s-AIS";
- a  $\pm 100$  ppm accurate AIS oscillator for the case of "64 kbit/s-AIS".

# 11 General performance

This clause specifies requirements involving several functions together and between interfaces.

## 11.1 Availability objectives

### 11.1.1 General

For a network provider, the reliability of network elements is of prime concern as it directly influences the availability of connections. However, the availability of a connection depends not only on the reliability of the network elements themselves but also on the level of network redundancy. Furthermore, it depends on the restoration times of the equipment involved. The restoration times depend to a great extent on the Operation, Administration and Management (OAM) philosophy of the network provider.

A manufacturer has, in most cases, requirements from several operators to take into account. Requirements from a certain network provider will depend on the level of economic development of the country concerned, the degree of market competition, customer requirements, the level of network redundancy, the level of maintenance support, etc.

The basis for determining the availability of a network element should be the analytical method for dependability as described in CCITT Recommendation E.862 [20].

The main point of the analytical method is that dependability aspects are taken into account as an economic factor. The level of availability is thus dimensioned according to cost-benefit analyses rather than by beforehand stated objectives.

The application of the method to network components is shown in the ITU-T handbook "Handbook on Quality of Service and Network Performance".

### 11.1.2 Parameters

The lifetime of an item can be divided into periods where the item is in an "up state" and can perform its task and periods where the item is out of order ("down state"). The related statistical measures are "Mean Time To Failure" (MTTF) and "Mean Down Time" (MDT).

Down times are not necessarily caused by failures but also by planned maintenance actions.

The asymptotic availability (A) of the item is calculated as:

$$A = \text{MTTF}/(\text{MTTF} + \text{MDT}) \approx \text{MTBF}/(\text{MTBF} + \text{MDT})$$

MTBF and MDT can either be calculated for a whole system or for parts or components of a system. From a network point of view failures that result in degradation or failure of a system, or of parts and/or components of a system, are of interest, even if only redundant parts have failed, which has no impact on the service supported by the system.

The dependability parameters are for further study. Tables 11, 12 and 13 show examples of parameters taken from ITU-T Recommendation G.911 [19].

**Table 11: System service parameters**

System service parameter	Units
Mean system availability	minimum/year unavailability
Mean channel availability	minimum/year unavailability. per channel
Operation system interface availability	minimum/year unavailability

**Table 12: System service parameters**

System service parameter	Units
System MTBF	years
Plug-in circuit packs MTBF	years
Frequency of scheduled maintenance actions	events per year
Random failure rate	events per year
Infant mortality factor	dimensionless

**Table 13: Active optical device reliability parameters**

Active optical device reliability parameter	Units
Median Life (ML)	years
Standard deviation ( $\sigma$ )	dimensionless
Wear-out failure rate at 10 years	FITs
Wear-out failure rate at 20 years	FITs
Wear-out activation energy (E)	eV
Random (steady-state) failure rate	FITs
Random failure activation energy (E)	eV

**Management unavailability:** is defined as the inability of the network element to communicate with the Operation System (OS); it corresponds to the unavailability of management functions or part of management functions and is expressed as a percentage of time.

**VC unavailability:** characterizes the unavailability of the functions involved in the treatment of a VC between the input and the output of an equipment and is expressed as a percentage of time.

**Total unavailability:** probability of a total inability for the equipment to maintain any traffic expressed as an MTBF value.

### 11.1.3 Derivation of MTBF values

Calculation of MTBF values based on FIT values should use the methodology described in ITU-T Recommendation G.911 [19].

## 11.2 Transfer delay

The transfer delay of an SDH equipment is for further study.

## 11.3 Jitter and wander

In order to control the overall network jitter and wander, the jitter and wander characteristics of all SDH based equipment needs to be specified at STM-N interfaces, PDH interfaces and synchronization interfaces. The specification needs to contain requirements for:

- jitter and wander generation;
- jitter and wander tolerance;
- jitter and wander transfer functions.

These requirements are described in subclauses 11.3.1, 11.3.2 and 11.3.3.

### 11.3.1 Jitter and wander generation

#### 11.3.1.1 Jitter and wander generation on STM-N signals

When an SSU is locked to an ideal signal which is derived from an external synchronization source the jitter / wander on the STM-N signal is for further study.

When an SEC is locked to an ideal signal which is derived from an external synchronization source the jitter / wander on the STM-N shall meet the requirements defined in EN 300 462-5-1 [26].

When the SEC or SSU is locked to an external timing reference source, the jitter / wander on the STM-N signal shall meet the requirements defined in EN 300 462-5-1 [26] (SEC) and for further study (SSU).

When an SEC or SSU is in holdover mode, the jitter / wander on the STM-N signal is for further study.

When an SEC or SSU is not locked to any synchronization reference signal and is not in holdover mode, it is free-running. In this case, the jitter / wander on the STM-N signal is for further study.

When MS-AIS is generated, the jitter / wander on the signal is for further study.

With no jitter applied at the STM-N input, an SDH regenerator shall generate not more than  $0,01 U_{I_{rms}}$  jitter. The measurement filter characteristics and the method of measurement are for further study (ITU-T Recommendation G.958 [18]).

#### 11.3.1.2 Jitter and wander generation on PDH interfaces

The SDH network may generate pointer justifications due to phase (frequency) differences in the network. The pointer justifications may cause large phase steps on the PDH interfaces if not processed in an appropriate way. The following subclause gives five test sequences of pointers and two tables of requirements (see note 1) which refer to the different sequences (see note 2):

- a) output jitter for a particular PDH interface in the absence of input jitter (either on the input PDH interface, the STM-N interface or on the synchronization interface) and in the absence of pointer adjustments. The requirements shall be met when the input frequency of the PDH interface is constant within the limits - a ppm to + a ppm from the nominal frequency. The value of "a" is defined in tables 14 and 15;
- b) combined output jitter for a particular PDH interface in the absence of input jitter (either on the input PDH interface, the STM-N interface or on the synchronization interface). The pointer test sequence shall be one single AU/TU pointer adjustment of one polarity followed by a 10 s recovery time T1 and then a single AU/TU pointer adjustment of the opposite polarity (see figure 60). The requirement shall be met when the input frequency of the PDH interface is constant within the limits - a ppm to + a ppm from the nominal frequency. Value of "a" is defined in tables 14 and 15;

NOTE 1: The values in tables 14 and 15 are under study in ETSI WG TM 3.

NOTE 2: The test sequences have been agreed only for TU pointers. For the AU pointers the test sequences are under study in ETSI WG TM 3.

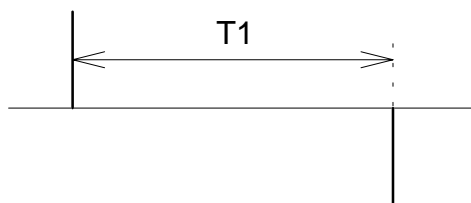

Figure 60: Test sequence B

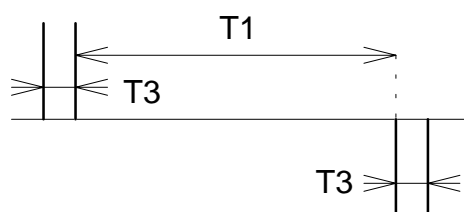

Figure 61: Test sequence C

- c) combined output jitter for a particular PDH interface in the absence of input jitter (either on the input PDH interface, the STM-N interface or on the synchronization interface). The pointer test sequence shall be a double AU/TU pointer adjustment of one polarity followed by a 10 s recovery time  $T1$  and then a double AU/TU pointer adjustment of the opposite polarity (see figure 61). The requirement shall be met when the input frequency of the PDH interface is constant within the limits  $-a$  ppm to  $+a$  ppm from the nominal frequency. Value of "a" is defined in tables 14 and 15;
- d) combined output jitter for a particular PDH interface in the absence of input jitter (either on the input PDH interface, the STM-N interface or on the synchronization interface). The pointer test sequence shall be regularly occurring AU/TU pointer adjustments of the same polarity plus a single pointer adjustment of the same polarity,  $T3$  seconds after a regular one (see figure 62). The requirements shall be met when the input frequency of the PDH interface is constant within the limits  $-a$  ppm to  $+a$  ppm from the nominal frequency. Value of "a" is defined in tables 14 and 15;

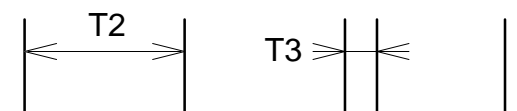

Figure 62: Test sequence D

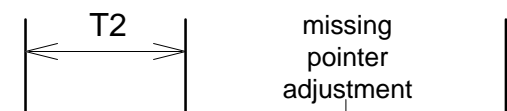

Figure 63: Test sequence E

- e) Combined output jitter for a particular PDH interface in the absence of input jitter (either on the input PDH interface, the STM-N interface or on the synchronization interface). The pointer test sequence shall be regularly occurring AU/TU pointer adjustments of the same polarity, with a single pointer adjustment missing from this sequence (see figure 63). The requirement shall be met when the input frequency of the PDH interface is constant within the limits  $-a$  ppm to  $+a$  ppm from the nominal frequency. Value of "a" is defined in tables 14 and 15.

Additional test patterns are currently under study in ITU and ETSI WG TM 3.

The following tables gives the maximum output jitter on CCITT Recommendation G.703 [7] interfaces with the sequences described above included. For mapping jitter (table 14), only sequence A applies.

Table 14: Maximum mapping jitter

Interface	a	Sequence	Filter characteristics			Maximum peak-peak mapping jitter	
			f1	f3	f4	f1 - f4	f3 - f4
	ppm		Hz	kHz	kHz	UI	UI
1 544	50	A	10		40	*	*
2 048	50	A	20	18	100	*	0,075
34 368	20	A	100	10	800	*	0,075
44 736	20	A	*	*	400	*	*
139 264	15	A	200	10	3 500	*	0,075

\* indicates "for further study".

Table 15: Maximum combined jitter

Interface	a	Sequence	Time intervals			Filter characteristics			Maximum peak-peak combined jitter	
			T1	T2	T3	f1	f3	f4	f1 - f4	f3 - f4
kbit/s	ppm		s	ms	ms	Hz	kHz	kHz	UI	UI
1 544	50	B, D, E	10	750	2	10		40	*	*
2 048	50	B, D, E	10	750	2	20	18	100	0,4	0,075
34 368	20	B, D, E	10	34	0,5	100	10	800	0,4	0,075
34 368	20	C	10	34	0,5	100	10	800	0,75	0,075
44 736	20	B-E	10	34	0,5	*	*	400	*	*
139 264	15	B, D, E	10	34	0,5	200	10	3 500	0,4	0,075
139 264	15	C	10	34	0,5	200	10	3 500	0,75	0,075

\* indicates "for further study".

### 11.3.1.3 Jitter and wander generation on 2 048 kHz or 2 048 kbit/s synchronization interfaces

In the absence of input jitter, output jitter at the synchronization interfaces should be  $< 0,05$  UIp-p measured with a band pass filter with cut off frequencies at 20 Hz and 100 kHz.

The output jitter and wander below 20 Hz is for further study.

## 11.3.2 Jitter and wander tolerance

### 11.3.2.1 Jitter and wander tolerance on optical interfaces

The peak-to-peak sinusoidal jitter amplitude applied on the STM-N interfaces signal that causes a maximum receiver penalty of 1 dB shall, at least, be within the limits of figure 2 of ITU-T Recommendation G.825 [16]. This shall be measured at an input optical power. The value of the measured BBER is for further study.

NOTE 1: The 1 dB penalty is according to ITU-T Recommendation G.958 [18]. However, jitter (wander) tolerance below  $f_0$  and above  $f_1$  also needs to be specified.

NOTE 2: No BBER value is specified in ITU-T Recommendation G.958 [18]. However, a certain level is necessary to be able to measure optical receiver sensitivity penalty caused by jitter. The BBER value corresponding to a BER value of  $10^{-10}$  is suggested.

NOTE 3: This jitter test is a stress test to ensure that no additional penalty is incurred under operating conditions.

### 11.3.2.2 Jitter and wander tolerance on traffic carrying electrical interfaces

The maximum permitted peak-to-peak sinusoidal jitter, when applied on the electrical interfaces, shall not cause any bit errors. The pulse mask shall be within the limits given in CCITT Recommendation G.703 [7]. The cable attenuation shall be the worst case value given in CCITT Recommendation G.703 [7]. The test pattern shall be a PRBS pattern of length  $2^{15}-1$  for 2 048 kbit/s and 1 544 kbit/s,  $2^{23}-1$  for the other interfaces (the electrical STM-1 may need a valid SOH and a valid pointer, therefore it is the VC-4 that shall have a  $2^{23}-1$  PRBS pattern). The mask shall be according to CCITT Recommendation G.823 [15].

### 11.3.2.3 Jitter and wander tolerance on 2 048 kHz and 2 048 kbit/s synchronization interfaces

The maximum permitted peak-to-peak sinusoidal jitter, when applied on the synchronization interfaces, shall not make the SEC/SSU loose tracking. The pulse mask shall be within the limits given in CCITT Recommendation G.703 [7]. The cable attenuation shall be the worst case value given in CCITT Recommendation G.703 [7]. The tolerance mask is for further study.

### 11.3.3 Jitter and wander transfer functions

The specific requirements for jitter transfer functions are currently under study in ETSI WG TM3.

### 11.3.4 Performance on synchronization reference change-over

The change-over of synchronization from one source to another (each traceable to the same PRC) shall be performed so that the resultant frequency / phase change is compliant with the MRTIE mask (constraint by disturbances) which is currently for further study.

The transition between synchronization sources may introduce a phase transient which may result in the generation of AU/TU pointer adjustments but should not introduce bit errors.

## 11.4 Error performance

The general error performance design objective is that no errors shall be introduced by the SDH equipment when operating within specified limits under the most adverse environmental conditions as specified in ETS 300 019 [4].

The specific requirement is that, when operating within specified limits under any combination of the environmental conditions given in ETS 300 019 [4], the equipment should be capable of providing a level of performance which is consistent with the support of paths meeting the performance classification identified in CCITT Recommendation G.821 [14] and ITU-T Recommendation G.826 [17].

## 11.5 Blocking factor

There is a class of connection matrix known as conditionally non-blocking in which there is a finite probability that a connection request may be blocked. In such connection matrices it is possible, by re-arranging existing connections, to make a connection which would otherwise be blocked. In such cases, re-arrangements should be made without interruption to re-arranged paths.

It may be necessary in a nominally non-blocking, or conditionally non-blocking connection matrix, to accept some blocking penalty associated with the extensive use of broadcast connections. This is for further study.

## 11.6 Connection set-up time

The connection set-up time is defined as the sum of two components:

- a) the message processing delay, which represents the time between the reception of a message on the Q interface port of the equipment and the generation of the corresponding primitive in the management communication layer function; and
- b) the matrix set-up delay, which corresponds to the time taken from the generation of a primitive in the management communication layer function to the corresponding change of transport information at the NNI.

It is useful to distinguish between two different cases:

- a) the set-up of new paths;
- b) the set-up of preset paths,

which may invoke different management facilities and have different associated time constraints.

The specific requirements for connection set-up time are for further study.



## Annex A (normative): Pointer generation

The pointer generation algorithm can be modelled by a finite state machine. Within the pointer generation algorithm, four states are defined:

- NORM\_state;
- NDF\_state;
- INC\_state;
- DEC\_state.

The transitions from the NORM state to the INC, DEC and NDF states are initiated by Elastic Store process events. The transitions from INC, DEC and NDF states to the NORM state occur autonomously under the generation of special pointer patterns.

NOTE 1: The insertion of the all-ONES (AIS) signal is controlled via the aSSF signal, and is performed outside the pointer generation process.

### Events

thr\_und: elastic store filling falls below a lower threshold;

thr\_exc: elastic store filling exceeds an upper threshold;

FO\_discont: frame offset discontinuity;

FO\_normal: normal frame offset.

NOTE 2: If a pointer interpreter controls the process of writing to the elastic store, a frame offset discontinuity occurs if an incoming NDF\_enable or  $3*\text{new\_point}$  is received, or if an elastic store overflow / underflow occurred.

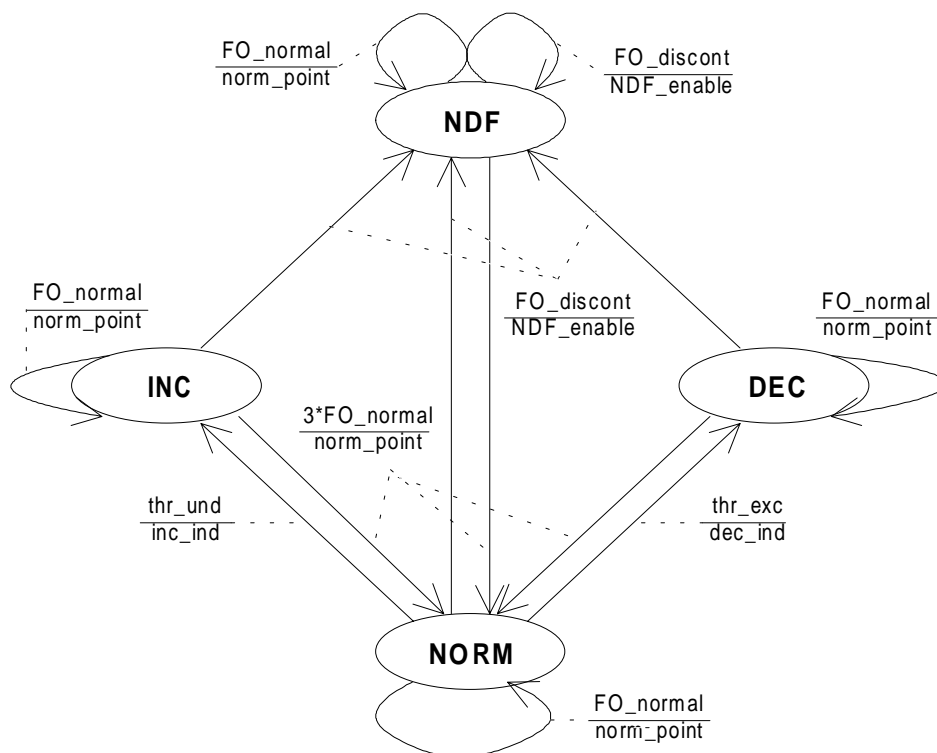

Figure A.1: Pointer generation state diagram

**Actions**

- inc\_ind: Transmit the pointer with NDF disabled and inverted I-bits, transmit a stuff byte in the byte after H3 (TU-3) or V3 (TU-2, TU-12), or transmit 3 stuff bytes in the 3 bytes after the third H3 byte (AU-4); increment active offset.
- dec\_ind: Transmit the pointer with NDF disabled and inverted D-bits, transmit a data byte in the byte H3 (TU-3) or V3 (TU-2, TU-12), or transmit 3 data bytes in the 3 H3 bytes (AU-4); decrement active offset.
- NDF\_enable: Accept new offset as active offset, transmit the pointer with NDF enabled and new offset.
- norm\_point: Transmit the pointer with NDF disabled and active offset.

NOTE 3: Active offset is defined as the phase between the outgoing STM-N frame and the HOVC, or between the HOVC and the LOVC. It is undefined during a signal fail condition. The pointer value is derived from the active offset. If the active offset is incremented or decremented, the first outgoing pointer value contains the original frame offset together with inverted I-bits, or D-bits.

NOTE 4: The ss-bits in the AU-4, TU-3 and TU-12 pointer are "10", the SS-bits in the TU-2 pointer are "00".

NOTE 5: NDF enabled is "1001", NDF disabled is "0110".

## Annex B (normative): Pointer interpretation

The pointer interpretation algorithm can be globally described by a state diagram while the detailed specifications are better suited by a state table.

### State diagram

Within the pointer interpretation algorithm six states are defined:

- NORMal\_state (NORM);
- AIS\_state (AIS);
- LOP\_state (LOP);
- INCrement\_state (INC);
- DECrement\_state (DEC);
- NDF\_state (NDF).

The transitions between the states will be initiated either by single events (inc, dec, ndf) or by a number of consecutive events (indications); e.g. three consecutive AIS indications to go from NORM\_state to the AIS\_state. The kind and number of consecutive indications activating a transition is chosen such that the behaviour is stable and insensitive to BER degradations.

It should be noted that non-consecutive invalid indications do not activate the transition to the LOP\_state.

### Events

The following state diagram events are defined:

- |             |                                                                                                                                           |
|-------------|-------------------------------------------------------------------------------------------------------------------------------------------|
| norm_point: | disabled NDF (0110,1110,0010,0100,0111)<br>AND match of ss-bits<br>AND received pointer offset value equal to active offset value;        |
| NDF_enable: | NDF enabled (1001,0001,1101,1011,1000)<br>AND match of ss-bits<br>AND received pointer offset value in range;                             |
| AIS_ind:    | pointer = 11111111 11111111 (FFH FFH);                                                                                                    |
| inc_ind:    | NDF disabled (0110,1110,0010,0100,0111)<br>AND match of ss-Bits<br>AND majority of I-bits inverted<br>AND no majority of D-bits inverted; |
| dec_ind:    | NDF disabled (0110,1110,0010,0100,0111)<br>AND match of ss-bits<br>AND majority of D-bits inverted<br>AND no majority of I-bits inverted; |

inv\_point: (Any other): NOT norm\_point  
 AND NOT NDF\_enable  
 AND NOT AIS\_ind  
 AND NOT [(inc\_ind OR dec\_ind) AND NORM\_state];

8×NDF\_enable: eight consecutive NDF\_enable;

3×AIS\_ind: three consecutive AIS\_ind;

8×inv\_point: eight consecutive inv\_point;

3×any\_point: 3× NOT NDF\_enable  
 AND NOT 3×AIS\_ind  
 AND NOT 3×new\_point.

One additional event (indication) has to be defined in order to restore normal operation in cases where, e.g. bit errors have corrupted the NDF bits during a NDF\_enable condition (see note 1):

new\_point: disabled NDF (0110,1110,0010,0100,0111)  
 AND match of ss-bits  
 AND received pointer offset value in range but not equal to active offset value

3×new\_point: three consecutive equal new\_point

NOTE 1: One other condition requires this restore operation: a re-routing or protection switch action in an connection function which operates synchronously. In that case the adaptation source, with the elastic store and pointer generator, is located before the switching function and is unable to detect and react on the frame phase discontinuity caused by the switch action.

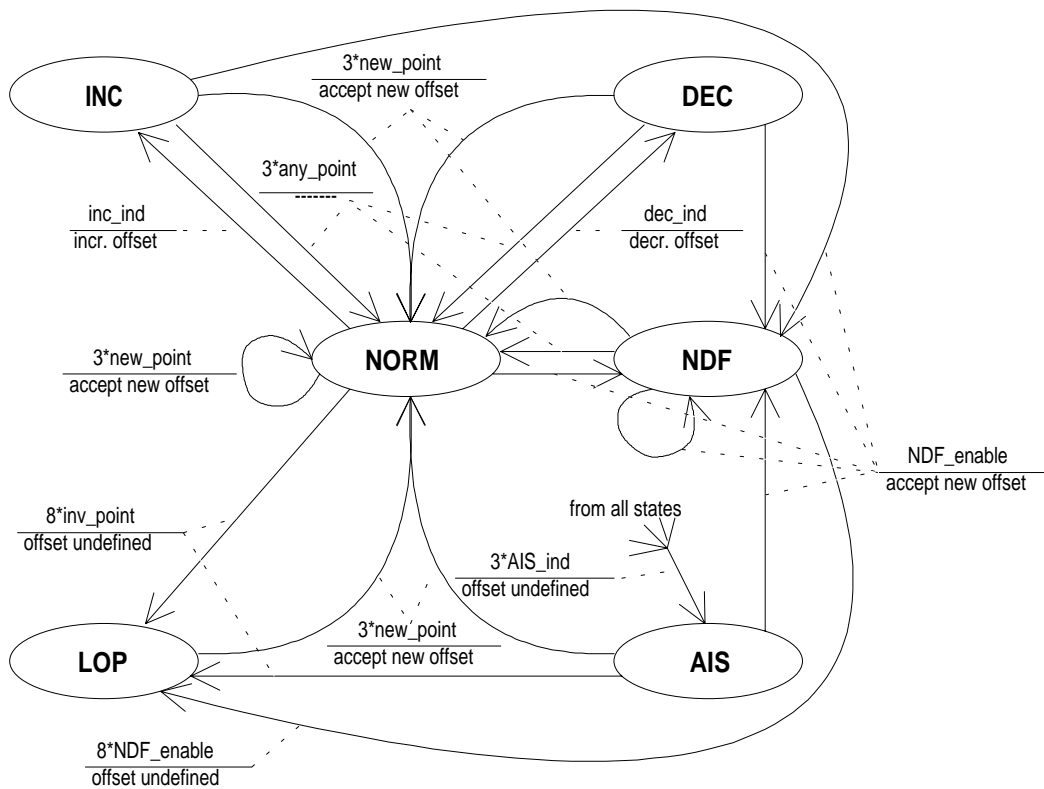

Figure B.1: Pointer interpretation state diagram

NOTE 2: Active offset is defined as the accepted current phase of the VC in the NORM\_state and is undefined in the other states.

NOTE 3: Enabled NDF is defined as one of the following bit patterns:  
1001; 0001; 1101; 1011; 1000.

NOTE 4: Disabled NDF is defined as one of the following bit patterns:  
0110; 1110; 0010; 0100; 0111.

NOTE 5: The remaining six NDF codes (0000, 0011, 0101, 1010, 1100, 1111) result in an inv\_point indication.

NOTE 6: In some applications interworking with North American countries may require that the ss-bits in the AU-n (n = 3,4) pointer be ignored.

NOTE 7: The new\_point is also an inv\_point.

NOTE 8: Only events causing transitions and/or actions are shown.

NOTE 9: 3×new\_point takes precedence over other events and reset the inv\_point count.

NOTE 10: The 2<sup>nd</sup> and 3<sup>rd</sup> offset value received in 3×new\_point needs to be identical with the 1<sup>st</sup>.

NOTE 11: The "consecutive new\_point" counter is reset to zero on a change of state, except for transitions occurring among INC, DEC, NDF states and the NORM state.

NOTE 12: The "consecutive inv\_point counter" can be incremented in all states. The "consecutive inv\_point" counter is not reset on a change of state taking into account note 8.

NOTE 13: The "consecutive AIS\_ind" counter is not reset on a change of state.

NOTE 14: The "consecutive NDF\_enable" counter is reset to zero on a change of AIS to NDF state; otherwise the counter is not reset.

NOTE 15: A persistent mismatch between provisioned and received AU and TU types will result in a LOP defect. The TU-12, TU-2 and TU-3 structures are differentiated in the PI process by their ss-bits values. The AU-3 and AU-4 structures have identical ss-bits values. Differentiation can be obtained by checking the Y bytes at locations (4,2,c) and (4,3,c).

### State table

For further study.

### Concatenated payloads

For the case of AU-4 concatenations (i.e. AU-4-Xc) the algorithms used to verify the presence of the Concatenation Indicator (CI) instead of the normal pointer can be described conveniently in the same way as for a normal pointer. This is shown by the state diagram of figure B.2. Three states have been described:

- CONCatenated\_state (CONC);
- AIS\_state (AISC);
- LOP\_state (LOPC).

NOTE 16: The AU-4 pointer is a non-concatenated pointer. It consists of the bytes H1 at location (4,1,c) and H2 at (4,4,c). The bytes at location (4,2,c), (4,3,c), (4,5,c) and (4,6,c) are fixed stuff with a specified value (CI).

The following state diagram events are defined:

- 3×AIS\_ind: three consecutive AIS\_ind
- 8×inv\_point: eight consecutive inv\_point
- 3×conc\_ind: three consecutive conc\_ind

in which:

conc\_ind: enabled NDF (1001,0001,1101,1011,1000)

AND "dd\_11\_11111111"

AIS\_ind: pointer = 11111111 11111111 (FFH FFH)

inv\_point: (Any other): NOT conc\_ind

AND NOT AIS\_ind

NOTE 17: dd bits are unspecified and are therefore "don't care" for the algorithm.

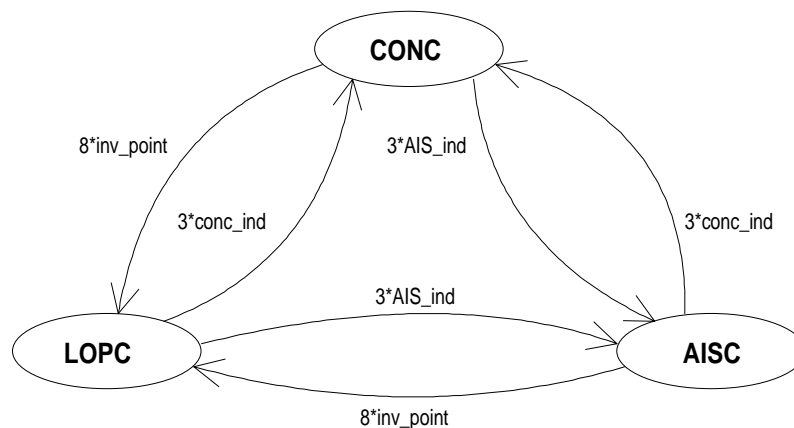

**Figure B.2: Concatenation Indicator state diagram**

A fault in one or more of the AU-4s of a concatenated payload should be reported as a single defect. Two types of defects can be reported:

- Loss Of Pointer of AU-4-Xc (LOPX);
- AIS of AU-4-Xc (AISX).

They are defined as follows:

AISX: AIS<sub>#1</sub> AND AIS<sub>#2</sub> AND ... AND AIS<sub>#X</sub>

NORMX: NORM<sub>#1</sub> AND CONC<sub>#2</sub> AND ... AND CONC<sub>#X</sub>

INCX: INC<sub>#1</sub> AND CONC<sub>#2</sub> AND ... AND CONC<sub>#X</sub>

DECX: DEC<sub>#1</sub> AND CONC<sub>#2</sub> AND ... AND CONC<sub>#X</sub>

NDFX: NDF<sub>#1</sub> AND CONC<sub>#2</sub> AND ... AND CONC<sub>#X</sub>

LOPX: (Any other): NOT AISX  
AND NOT NORMX  
AND NOT INCX  
AND NOT DECX  
AND NOT NDFX

## Annex C (informative): Network "production rules"

The relationship between trails, (sub-)network connections, link connections, atomic functions, and reference points can be described by means of the "production rules" of a network. This kind of formalism can also be found in software language specifications. One of the methods used to describe a language is the Backus-Naur Form (BNF) (see note). This shows the decomposition and partitioning processes described in clause 3 of ITU-T Recommendation G.803 [6].

NOTE: BNF is a syntax metalanguage. A metalanguage is a language that is used to describe other languages. The symbols "<", ">", and "::=" are symbols of the metalanguage and not the language being described. The symbol "::=" stands for "is defined as". The entities inside the metalanguage brackets "<" and ">" are called *non-terminals*; an entity outside of the metalanguage brackets is called a *terminal*. A non-terminal appearing on the *left-hand side* of "::=" is defined by the definition on the *right-hand side* of "::=". Non-terminals on the right-hand side shall be defined with other BNF rules; terminals shall be valid symbols of the language. The symbol "|" is read "or" and is used to provide alternative definitions for the same non-terminal.

```

<trail> ::= AP <termination> <network connection>
          <termination> AP

<network connection> ::= TCP <sub-network connection α> TCP

<sub-network connection α> ::= <sub-network connection α> CP <link connection> CP
                              <sub-network connection α>

                              | <simple connection>

                              | <tandem connection>

<link connection> ::= <adaptation> <trail> <adaptation>

                              | Transmission_Medium

<simple connection> ::= Degenerate_Connection

                              | Matrix_Connection (C)

<adaptation> ::= Adaptation (A)

<termination> ::= Trail_Termination (TT)

<tandem connection> ::= <Dadaptation> AP_D <Dtermination> TCP_D
                       <sub-network connection β> TCP_D
                       <Dtermination> AP_D <Dadaptation>

<sub-network connection β> ::= <sub-network connection β > CP <link connection>
                              CP <sub-network connection β>

                              | <simple connection>

<Dadaptation> ::= Domain_Monitoring_Adaptation (D_A)

<Dtermination> ::= Domain_Monitoring_Trail_Termination (D_T)

AP_D: Domain Monitoring Access Point
CP_D: Domain monitoring Connection Point
TCP_D: Domain Monitoring Termination Connection Point
TM: Transmission_Medium

```

The <sub-network connection> shows the recursion, which terminates when the <simple connection> is selected. This <simple connection> represents the cross-connection on an individual matrix, or an inflexible (fixed) connection for the case where a matrix is not present. It is represented by the (flexible) connection function or an (inflexible) line.

The <link connection> shows the layering process, which terminates when the Transmission\_Medium is selected.

The concept of the <tandem connection> is introduced here because it is considered to provide a rigid way of describing the property that is required for the so-called tandem connection i.e. a sub-network connection that can be monitored via an overhead dedicated for this purpose.

The addition of a rigid set of syntax rules is for further study.



## Annex D (informative): Flexible assignment of tributary port to VC-12 capacity

An external tributary port may be assigned to a particular payload capacity using a connection function.

EXAMPLE: at the VC-12 level:

Tributary #1 - TU-12 (1,1,1)

Tributary #2 - TU-12 (1,1,2)

Tributary #3 - TU-12 (1,1,3)

Tributary #4 - TU-12 (1,2,1)

:

:

Tributary #63 - TU-12 (3,7,3)

However, in general there may be no fixed relationship between TU capacity within the STM-N signal and physical ports (which may be part of a different network layer). The principle is illustrated for the VC-12 application in figure D.1.

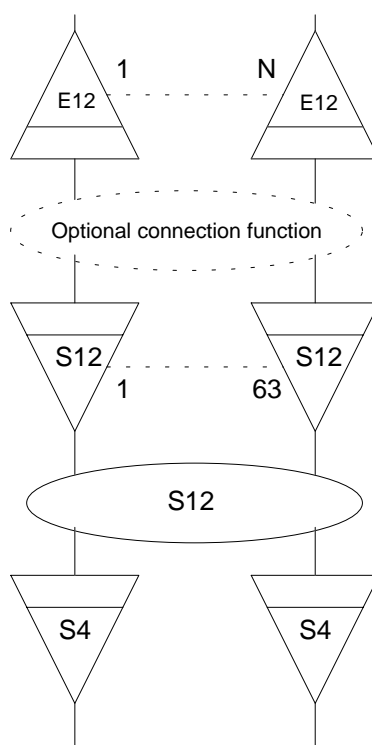

Figure D.1: Illustration of flexible assignment of tributary port to VC-12 capacity

## Annex E (informative): Relationship between TU-2/12 address, and location of columns within a VC-4

Table E.1

TU-2 address			location of columns in a VC-4 occupied by TU-2 (k, l, m)											
K	L	M												
1	1	0	10	31	52	73	94	115	136	157	178	199	220	241
1	2	0	13	34	55	76	97	118	139	160	181	202	223	244
1	3	0	16	37	58	79	100	121	142	163	184	205	226	247
1	4	0	19	40	61	82	103	124	145	166	187	208	229	250
1	5	0	22	43	64	85	106	127	148	169	190	211	232	253
1	6	0	25	46	67	88	109	130	151	172	193	214	235	256
1	7	0	28	49	70	91	112	133	154	175	196	217	238	259
2	1	0	11	32	53	74	95	116	137	158	179	200	221	242
2	2	0	14	35	56	77	98	119	140	161	182	203	224	245
2	3	0	17	38	59	80	101	122	143	164	185	206	227	248
2	4	0	20	41	62	83	104	125	146	167	188	209	230	251
2	5	0	23	44	65	86	107	128	149	170	191	212	233	254
2	6	0	26	47	68	89	110	131	152	173	194	215	236	257
2	7	0	29	50	71	92	113	134	155	176	197	218	239	260
3	1	0	12	33	54	75	96	117	138	159	180	201	222	243
3	2	0	15	36	57	78	99	120	141	162	183	204	225	246
3	3	0	18	39	60	81	102	123	144	165	186	207	228	249
3	4	0	21	42	63	84	105	126	147	168	189	210	231	252
3	5	0	24	45	66	87	108	129	150	171	192	213	234	255
3	6	0	27	48	69	90	111	132	153	174	195	216	237	258
3	7	0	30	51	72	93	114	135	156	177	198	219	240	261

Table E.2

TU-12 address			location of columns in a VC-4 occupied by TU-12 (k, l, m)			
K	L	M				
1	1	1	10	73	136	199
1	1	2	31	94	157	220
1	1	3	52	115	178	241
1	2	1	13	76	139	202
1	2	2	34	97	160	223
1	2	3	55	118	181	244
1	3	1	16	79	142	205
1	3	2	37	100	163	226
1	3	3	58	121	184	247
1	4	1	19	82	145	208
1	4	2	40	103	166	229
1	4	3	61	124	187	250
1	5	1	22	85	148	211
1	5	2	43	106	169	232
1	5	3	64	127	190	253
1	6	1	25	88	151	214
1	6	2	46	109	172	235
1	6	3	67	130	193	256
1	7	1	28	91	154	217
1	7	2	49	112	175	238
1	7	3	70	133	196	259

Table E.3

TU-12 address			location of columns in a VC-4 occupied by TU-12 (k, l, m)			
K	L	M				
2	1	1	11	74	137	200
2	1	2	32	95	158	221
2	1	3	53	116	179	242
2	2	1	14	77	140	203
2	2	2	35	98	161	224
2	2	3	56	119	182	245
2	3	1	17	80	143	206
2	3	2	38	101	164	227
2	3	3	59	122	185	248
2	4	1	20	83	146	209
2	4	2	41	104	167	230
2	4	3	62	125	188	251
2	5	1	23	86	149	212
2	5	2	44	107	170	233
2	5	3	65	128	191	254
2	6	1	26	89	152	215
2	6	2	47	110	173	236
2	6	3	68	131	194	257
2	7	1	29	92	155	218
2	7	2	50	113	176	239
2	7	3	71	134	197	260

Table E.4

TU-12 address			location of columns in a VC-4 occupied by TU-12 (k, l, m)			
K	L	M				
3	1	1	12	75	138	201
3	1	2	33	96	159	222
3	1	3	54	117	180	243
3	2	1	15	78	141	204
3	2	2	36	99	162	225
3	2	3	57	120	183	246
3	3	1	18	81	144	207
3	3	2	39	102	165	228
3	3	3	60	123	186	249
3	4	1	21	84	147	210
3	4	2	42	105	168	231
3	4	3	63	126	189	252
3	5	1	24	87	150	213
3	5	2	45	108	171	234
3	5	3	66	129	192	255
3	6	1	27	90	153	216
3	6	2	48	111	174	237
3	6	3	69	132	195	258
3	7	1	30	93	156	219
3	7	2	51	114	177	240
3	7	3	72	135	198	261

## Annex F (informative): Performance monitoring history process

Figures F.1 to F.3 illustrate the PM logging (history management) process.

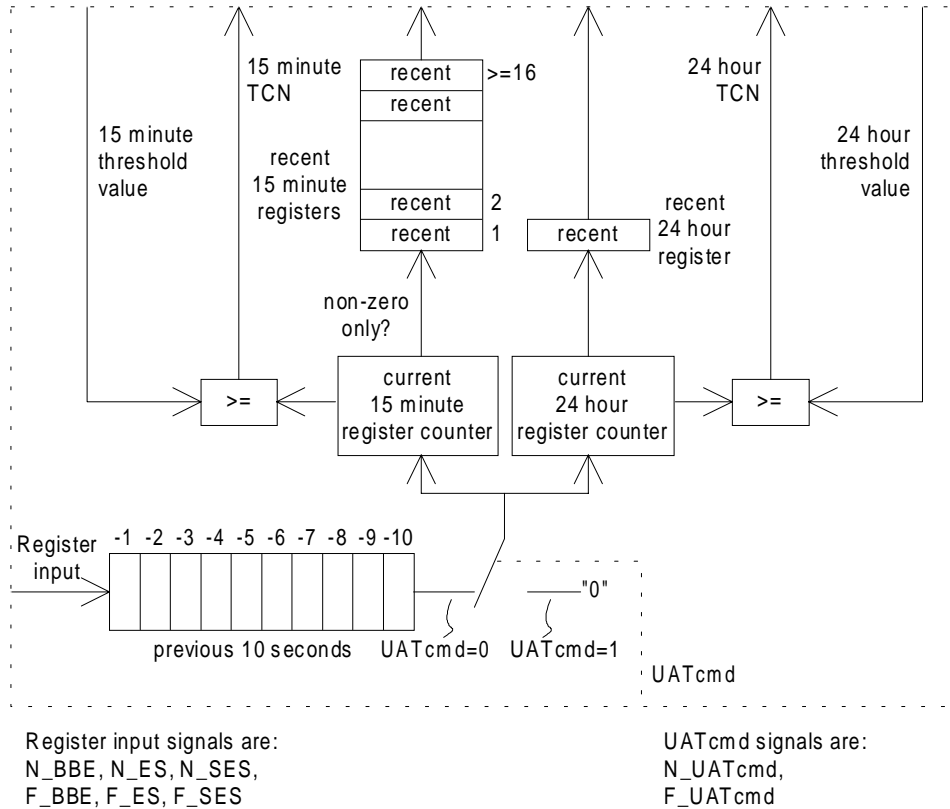

The XXX (XXX is N\_ES, N\_SES, N\_BBE, F\_ES, F\_SES, F\_BBE) are temporarily stored in a 10 second FIFO buffer. The output is connected to a switch which is connected to the input of the current 15 minutes and 24 hours REGISTER counters. The other input of the switch is connected to (value) "0". If the UATcmd equals "0", the switch selects the FIFO, otherwise the '0' input is selected. Every second, the REGISTER counters add the applied input value (XXX or '0') to the count. If the count equals the "Threshold value" a TCN is generated. If the value in the REGISTERS is non-zero at the end of the (15 minute, 24 hour) period, it is copied into "recent register #1", while all values present shift one position as in a FIFO. The values in the 10 second FIFO shift one position every second, independent of the switch state.

**Figure F.1: Logging process for BBE, ES and SES**

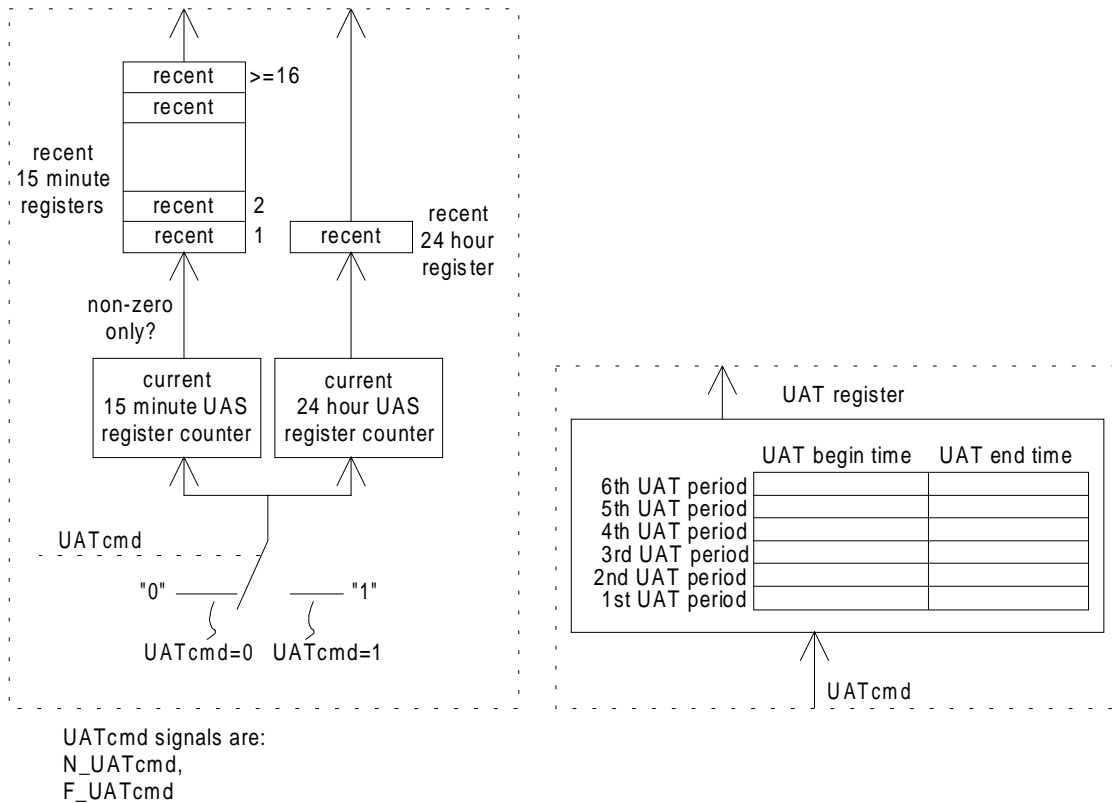

The UAT register is capable of logging 6 UAT periods. It stores the begin and end times of UAT periods. UAS logging is similar to ES/SES/BBE logging, except that it is not necessary to store 10 seconds of information. Every second during UATcmd = 1 (active) is an UAS and increments the REGISTER counters.

**Figure F.2: Logging process for UAT and UAS**

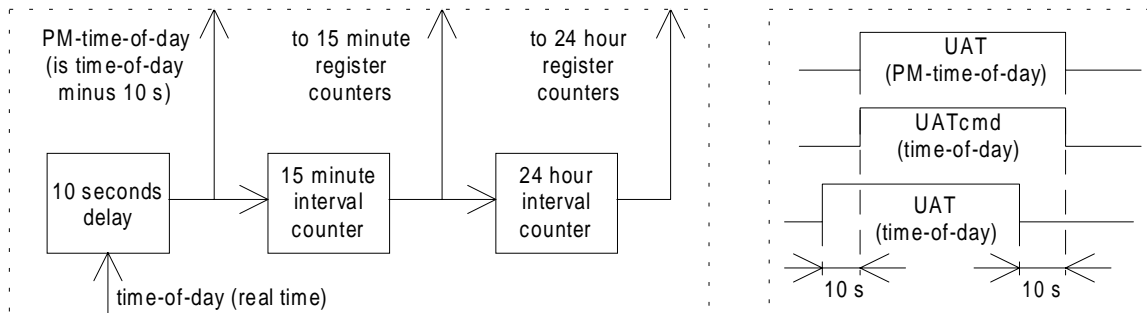

During UAT the logging of ES, SES and BBE is "stopped" (see figure F.1). To realize a linear process data processing is delayed by 10 seconds. To align time stamping, the PM time is also delayed by this 10 seconds.

**Figure F.3: PM time of day process**

## Annex G (informative): Protection switch examples

### 1+1 VC-12 trail protection:

- protection model: see figure 50;
- protection architecture: 1+1;
- switching type: single-ended, dual-ended;
- operation type: non-revertive or revertive;
- protection switch requests:
  - CONDITIONS: SF = S12P\_CI\_SSF (= S12\_AI\_TSF) and SD = S12P\_CI\_SSD (= S12\_AI\_TSD);
  - EXTERNAL: Clear, Freeze, Lockout, Forced Switch #i (i = 1,2), Manual Switch;
- protection switch performance: switching after SF or SD activation within X ms. The value of X is for further study;
- automatic protection switch channel: K4 bits 1 to 4 (presumably in a multiframe structure).

### 1+1 VC-12 SNC/I protection:

- protection model: see figure 54;
- protection architecture: 1+1;
- switching type: single-ended;
- operation type: non-revertive or revertive;
- protection switch requests:
  - CONDITION: SF = S12\_CI\_SSF;
  - EXTERNAL: Clear, Freeze, Lockout, Forced Switch #i (i = 1,2), Manual Switch;
- protection switch performance: switching after SF activation within Y ms. The value of Y is for further study;
- automatic protection switch channel: not applicable.

### 1+1 VC-12 SNC/N protection:

- protection model: see figure 55;
- protection architecture: 1+1;
- switching type: single-ended;
- operation type: non-revertive or revertive;
- protection switch requests:
  - CONDITIONS: SF = S12\_AI\_TSF and SD = S12\_AI\_TSD;
  - EXTERNAL: Clear, Freeze, Lockout, Forced Switch #i (i = 1,2), Manual Switch;
- protection switch performance: switching after SF or SD activation within Z ms. The value of Z is for further study;
- automatic protection switch channel: not applicable.

---

## Bibliography

- ETS 300 417-2-1: "Transmission and Multiplexing (TM); Synchronous Digital Hierarchy (SDH) and Plesiochronous Digital Hierarchy (PDH) physical section layer function".
- EN 300 417-2-1: "Transmission and Multiplexing (TM); Generic requirements of transport functionality of equipment; Part 2-1: Synchronous Digital Hierarchy (SDH) and Plesiochronous Digital Hierarchy (PDH) physical section layer functions".
- EN 300 417-3-1: "Transmission and Multiplexing (TM); Generic requirements of transport functionality of equipment; Part 3-1: Synchronous Transport Module-N (STM-N) regenerator and multiplex section layer functions".
- EN 300 417-4-1: "Transmission and Multiplexing (TM); Generic requirements of transport functionality of equipment; Part 4-1: Synchronous Digital Hierarchy (SDH) path layer functions".
- EN 300 417-5-1: "Transmission and Multiplexing (TM); Generic requirements of transport functionality of equipment; Part 5-1: Plesiochronous Digital Hierarchy (PDH) path layer functions".
- EN 300 417-6-1: "Transmission and Multiplexing (TM); Generic requirements of transport functionality of equipment; Part 6-1: Synchronization layer functions".
- EN 300 417-7-1: "Transmission and Multiplexing (TM); Generic requirements of transport functionality of equipment; Part 7-1: Auxiliary layer functions".
- EN 300 462-3-1: "Transmission and Multiplexing (TM); Generic requirements for synchronization networks; Part 3-1: The control of jitter and wander within synchronization networks".
- EN 300 462-4-1: "Transmission and Multiplexing (TM); Generic requirements for synchronization networks; Part 4-1: Timing characteristics of slave clocks suitable for synchronization supply to Synchronous Digital Hierarchy (SDH) and Plesiochronous Digital Hierarchy (PDH) equipment".
- ETS 300 746: "Transmission and Multiplexing (TM); Synchronous Digital Hierarchy (SDH); Network protection schemes; Automatic Protection Switch (APS) protocols and operation".
- IEC 825: "Safety of laser products";
- ITU-T handbook: "Handbook on Quality of Service and Network Performance";
- TS 101 009: "Transmission and Multiplexing (TM); Synchronous Digital Hierarchy (SDH); Network protection schemes; Types and characteristics".
- TS 101 110: "Transmission and Multiplexing (TM); Synchronous Digital Hierarchy (SDH); Network protection schemes; Interworking: rings and other schemes".

## History

<b>Document history</b>		
Edition 1	January 1996	Publication as ETS 300 417-1-1
V1.1.2	November 1998	Publication (Converted to EN 300 417-1-1)
V1.1.3	May 1999	Publication