

ETSI EN 300 408 V1.2.1 (2000-09)

European Standard (Telecommunications series)

**Fixed Radio Systems;
Point-to-point equipment;
Parameters for digital radio systems for the transmission
of digital signals and analogue video signals
operating at around 58 GHz, which do not require
co-ordinated frequency planning**



Reference

REN/TM-04072

Keywords

DRRS, point-to-point, transmission, radio

ETSI

650 Route des Lucioles
F-06921 Sophia Antipolis Cedex - FRANCE

Tel.: +33 4 92 94 42 00 Fax: +33 4 93 65 47 16

Siret N° 348 623 562 00017 - NAF 742 C
Association à but non lucratif enregistrée à la
Sous-Préfecture de Grasse (06) N° 7803/88

Important notice

Individual copies of the present document can be downloaded from:

<http://www.etsi.org>

The present document may be made available in more than one electronic version or in print. In any case of existing or perceived difference in contents between such versions, the reference version is the Portable Document Format (PDF). In case of dispute, the reference shall be the printing on ETSI printers of the PDF version kept on a specific network drive within ETSI Secretariat.

Users of the present document should be aware that the document may be subject to revision or change of status. Information on the current status of this and other ETSI documents is available at <http://www.etsi.org/tb/status/>

If you find errors in the present document, send your comment to:
editor@etsi.fr

Copyright Notification

No part may be reproduced except as authorized by written permission.
The copyright and the foregoing restriction extend to reproduction in all media.

© European Telecommunications Standards Institute 2000.
All rights reserved.

Contents

Intellectual Property Rights	5
Foreword.....	5
1 Scope	6
2 References	6
3 Symbols and abbreviations.....	7
3.1 Symbols.....	7
3.2 Abbreviations	8
4 General characteristics	8
4.1 Frequency bands and channel arrangements	8
4.1.1 Frequency band.....	8
4.1.2 Radio Channel Arrangements	8
4.1.3 RF-channel Selection.....	8
4.1.3.1 RF-channel selection procedure	8
4.1.3.2 Interference avoidance requirements.....	9
4.1.3.2.1 Interference avoidance limit	9
4.1.3.2.2 Interference avoidance limit calibration	9
4.1.3.3 Frequency agility.....	9
4.1.4 Transmit/receive frequency separation	9
4.2 Environmental Conditions.....	9
4.2.1 Equipment within weather protected locations (indoor locations).....	9
4.2.2 Equipment for non-weather protected locations (outdoor locations).....	10
4.3 Electromagnetic Compatibility.....	10
4.4 Baseband Interface	10
4.5 System block diagram	10
4.6 Antennas and RF-interface	11
4.6.1 Antenna Requirements.....	11
4.6.2 RF interface	11
4.7 Power supply	11
5 Parameters for digital systems.....	11
5.1 Transmission capacity	11
5.2 Error-performance and availability requirements for Class A equipment.....	11
5.3 Transmitter characteristics.....	12
5.3.1 Transmitter power.....	12
5.3.1.1 Transmitter power range	12
5.3.1.2 Equivalent Isotropically Radiated Power (EIRP).....	12
5.3.2 Radiated Spectrum.....	12
5.3.2.1 RF spectrum mask.....	12
5.3.2.2 Spurious emissions.....	12
5.3.3 Radio frequency tolerance	12
5.4 Receiver characteristics	12
5.4.1 Spurious emissions	12
6 Parameters for wideband analogue systems	13
6.1 Transmitter characteristics.....	13
6.1.1 Power	13
6.1.1.1 Transmitter power range	13
6.1.1.2 EIRP	13
6.1.2 Radiated spectrum	13
6.1.2.1 Spectrum mask.....	13
6.1.2.2 Spurious emissions.....	13
6.1.3 RF frequency tolerance	13
6.2 Receiver characteristics, spurious emissions	13

Annex A (informative):	Additional information	15
A.1	Additional information on Class A and Class B	15
A.2	Radio frequency channel arrangement	15
A.3	Antenna alignment procedures	16
Annex B (normative):	Essential requirements for the EC Council Directive 89/336 (EMC Directive)	17
Annex C (normative):	System type codes for regulatory procedures	18
Annex D (informative):	Rationale for the interference limit formula	19
D.1	Analysis of the quality value for the channel selection procedure	19
D.1.1	Theoretical background	19
D.1.2	Typical co-channel interference situation when channel rejection threshold is used	19
D.2	Protection capability of the RF-channel selection procedure	20
D.3	Frequency agility criteria.....	21
	Bibliography	22
	History	23

Intellectual Property Rights

IPRs essential or potentially essential to the present document may have been declared to ETSI. The information pertaining to these essential IPRs, if any, is publicly available for **ETSI members and non-members**, and can be found in ETSI SR 000 314: "*Intellectual Property Rights (IPRs); Essential, or potentially Essential, IPRs notified to ETSI in respect of ETSI standards*", which is available from the ETSI Secretariat. Latest updates are available on the ETSI Web server (<http://www.etsi.org/ipr>).

Pursuant to the ETSI IPR Policy, no investigation, including IPR searches, has been carried out by ETSI. No guarantee can be given as to the existence of other IPRs not referenced in ETSI SR 000 314 (or the updates on the ETSI Web server) which are, or may be, or may become, essential to the present document.

Foreword

This European Standard (Telecommunications series) has been produced by ETSI Technical Committee Transmission and Multiplexing (TM).

National transposition dates	
Date of adoption of this EN:	7 July 2000
Date of latest announcement of this EN (doa):	31 October 2000
Date of latest publication of new National Standard or endorsement of this EN (dop/e):	30 April 2001
Date of withdrawal of any conflicting National Standard (dow):	30 April 2001

1 Scope

The present document specifies the minimum performance requirements for terrestrial fixed service radiocommunications equipment operating in the 58 GHz frequency band which do not require co-ordinated frequency planning.

The frequency band is proposed to be used by various technologies for uncoordinated use of the band. It also benefits from the high and stable atmospheric attenuation which suppresses efficiently distant interferers (about 10 to 15 dB/km at sea level, refer to ITU-R Recommendation P.676 [16]).

For the purposes of the present document two equipment Classes are specified depending on the network requirements:

- Class A: Digital equipment for High Density Fixed Service (HDFS) applications typically connected to public networks, which apply the RF-channel selection procedure (see subclause 4.1.3), error performance and availability requirements (see subclause 5.2).
- Class B: Equipment without requirements for quality of service, typically private network connections.

Typical applications for Class A equipment are e.g. interconnection between cellular networks where there, in some cases, is a need for short length connections (up to about 500 meters). The RF channel selection procedure shall be used to protect existing systems from a new system being commissioned. However, the channel selection procedure may not guarantee interference free installation or operation in all cases due to limitations in the procedure with respect to the variety of systems.

Typical applications for Class B equipment are in private networks, such as video surveillance systems.

The present document does not contain aspects related to test procedures and test conditions, however they are to be found in EN 301 126-1 [6].

Safety aspects are outside the mandate of ETSI and they will not be considered in the present document. However compliance to CENELEC EN 60950 [17] will be required to comply with 99/5/EC [18] Directive (R&TTE).

Technical background for the parameters and requirements referred in the present document may be found in TR 101 036-1 [15].

2 References

The following documents contain provisions which, through reference in this text, constitute provisions of the present document.

- References are either specific (identified by date of publication, edition number, version number, etc.) or non-specific.
- For a specific reference, subsequent revisions do not apply.
- For a non-specific reference, the latest version applies.
- A non-specific reference to an ETS shall also be taken to refer to later versions published as an EN with the same number.

- [1] ETSI ETS 300 132-1: "Equipment Engineering (EE); Power supply interface at the input to telecommunications equipment; Part 1: Operated by alternating current (ac) derived from direct current (dc) sources".
- [2] ETSI ETS 300 132-2: "Equipment Engineering (EE); Power supply interface at the input to telecommunications equipment; Part 2: Operated by direct current (dc)".
- [3] ETSI ETS 300 019 (all parts): "Equipment Engineering (EE); Environmental conditions and environmental tests for telecommunications equipment".

- [4] ETSI EN 301 489-4: "Electromagnetic compatibility and Radio spectrum Matters (ERM); ElectroMagnetic Compatibility (EMC) standard for radio equipment and services; Part 4: Specific conditions for fixed radio links and ancillary equipment and services".
- [5] CEPT/ERC Recommendation 12-09: "Radio frequency channel arrangement for fixed service systems operating in the band 57,0 GHz to 59,0 GHz which do not require frequency planning".
- [6] ETSI EN 301 126-1: "Fixed Radio Systems; Conformance testing; Part 1: Point-to-Point equipment - Definitions, general requirements and test procedures".
- [7] ITU-R F.ANPER: "Availability objectives for real digital radio-relay links forming part of the national portion constant bit rate digital path at or above the primary rate".
- [8] ITU-T Recommendation G.703: "Physical/electrical characteristics of hierarchical digital interfaces".
- [9] CEPT/ERC Recommendation 74-01: "Spurious emissions".
- [10] ITU-R Recommendation F.1191: "Bandwidths and unwanted emissions of digital radio-relay systems".
- [11] ITU-T Recommendation G.826: "Error performance parameters and objectives for international, constant bit rate digital paths at or above the primary rate".
- [12] ITU-R Recommendation F.1189: "Error performance objectives for constant bit rate digital paths at or above the primary rate carried by digital radio-relay systems which may form part or all of the national portion of a 27 500 km hypothetical reference path".
- [13] ETSI ETS 300 833 (1999): "Fixed Radio Systems; Point to Point Antennas; Antennas for point-to-point fixed radio systems operating in the frequency band 3 GHz to 60 GHz".
- [14] ITU-R Recommendation F.697: "Error performance and availability objectives for the local-grade portion at each end of an ISDN connection at a bit rate below the primary rate utilizing digital radio-relay systems".
- [15] ETSI TR 101 036-1 (V1.3): "Fixed Radio Systems; Generic wording for standards on Digital Radio Equipment characteristics; Part 1: General aspects and point-to-point equipment parameters".
- [16] ITU-R Recommendation P.676: "Attenuation by atmospheric gases".
- [17] CENELEC, EN 60950: "Safety of information technology equipment".
- [18] Directive 1999/5/EC of the European Parliament and of the Council of 9 March 1999 on radio equipment and telecommunications equipment and the mutual recognition of their conformity.
- [19] ITU-T Recommendation O.151: "Error performance measuring equipment operating at the primary rate and above".
- [20] Directive EMC 89/336/EEC on the approximation of the laws of the Member States relating to electromagnetic compatibility".

3 Symbols and abbreviations

3.1 Symbols

For the purposes of the present document, the following symbols apply:

dB	decibel
dBm	decibel relative to 1 milliWatt
dBW	decibel relative to 1 Watt
GHz	GigaHertz

kHz	kiloHertz
km	kilometre
MHz	MegaHertz
ppm	parts per million
V	volts

3.2 Abbreviations

For the purposes of the present document, the following abbreviations apply:

AC	Alternating current
BER	Bit Error Ratio
BW	Equivalent noise bandwidth
CW	Continuous Wave
DC	direct current
DRRS	Digital Radio Relay Systems
EIRP	Equivalent Isotropically Radiated Power
EMC	ElectroMagnetic Compatibility
EN	Euronorm
FDD	Frequency Division Duplex
HDFS	High Density Fixed Service
PDH	Plesiochronous Digital Hierarchy
Pi	Interference Power
RF	Radio Frequency
Rx	Receiver
TDD	Time Division Duplex
Tx	Transmitter

4 General characteristics

4.1 Frequency bands and channel arrangements

4.1.1 Frequency band

The frequency band is from 57 GHz to 59 GHz.

NOTE: The successful co-existence of Class A and Class B equipment may require the regulator to define exclusive spectrum for each equipment Class (see annex A).

4.1.2 Radio Channel Arrangements

The channel arrangements are specified in CEPT/ERC Recommendation 12-09 [5] with 50 MHz or 100 MHz channel rasters. For reader convenience, the basic parameters of the CEPT Recommendation are shown in informative annex A.

4.1.3 RF-channel Selection

RF-channel selection procedure is mandatory for Class A equipment only.

4.1.3.1 RF-channel selection procedure

The purpose of the RF-channel selection procedure is to detect and protect existing transmissions in order to avoid unacceptable interference situations.

At both transmission sites, radio-relay terminals shall measure during installation, the interference levels of both receive and transmit channels (Note). Only in the instance when an unoccupied channel is identified and selected as the transmission channel shall the transmit power be switched on. The interference avoidance requirements for the receiver to detect occupied channels are specified in subclause 4.1.3.2 below.

The principle of protecting existing transmission shall be respected also during the antenna alignment (see annex A for examples of possible antenna alignment procedures)

NOTE: If the national regulatory rules allows to change the frequency of the link during its operation, it may be considered, in order to decrease the possibility of undetected interference, to apply the RF channel selection procedure whenever appropriate (e.g. when restoring a link after a failure or by suitable automatic timed routine in conjunction with frequency agility as in subclause 4.1.3.3).

4.1.3.2 Interference avoidance requirements

4.1.3.2.1 Interference avoidance limit

The radio relay terminal shall consider the radio channel occupied when the level of the interference is above the following limit:

- $P_i > -81 \text{ dBm} + 10 \log (BW/10 \text{ MHz})$.

Where:

- BW is the noise bandwidth of the receiver expressed in MHz.
- P_i is the interference power expressed in dBm measured within the receiver noise bandwidth (BW).

For the rationale of the interference limit formula see informative annex D.

4.1.3.2.2 Interference avoidance limit calibration

The interference avoidance limit of the radio relay terminal shall be calibrated with the CW test signal connected to the reference point D (antenna port) of the terminal at any frequency within the receiver noise bandwidth or at any frequency within the transmitter spectrum limits, containing 90% of the transmit power.

4.1.3.3 Frequency agility

Frequency agility is an optional feature.

If unacceptable interference which exceeds a predetermined duration is observed an automatic change of RF-channel can be initiated using the RF-channel selection procedure described above. If an automatic RF-channel change facility is implemented a means shall be provided to disable it. Unacceptable interference criteria shall be declared by the manufacturer (see informative annex D, clause D.3).

4.1.4 Transmit/receive frequency separation

No specific requirements for Tx/Rx –separation.

4.2 Environmental Conditions

The equipment shall be required to meet the environmental conditions set out in ETS 300 019 [3], which defines weather protected and outdoor environmental Classes and test severities. The manufacturer shall state which Class the equipment is designed to withstand.

4.2.1 Equipment within weather protected locations (indoor locations)

Equipment intended for operation within temperature controlled locations or partially temperature-controlled locations shall meet the requirements of ETS 300 019 [3] Classes 3.1 and 3.2 respectively.

Optionally, the more stringent requirements of ETS 300 019 [3] Classes 3.3 (non-temperature-controlled locations), 3.4 (sites with heat trap) and 3.5 (sheltered locations) may be applied.

4.2.2 Equipment for non-weather protected locations (outdoor locations)

Equipment intended for operation within non-weather protected locations shall meet the requirements of ETS 300 019 [3], Class 4.1 or 4.1E.

Class 4.1 applies to many European countries and Class 4.1E applies to all European countries.

4.3 Electromagnetic Compatibility

Equipment shall operate under the conditions specified in ETS 300 385 [4].

4.4 Baseband Interface

When standard interfaces are provided they shall comply with ITU-T standards recognized by ETSI.

In some applications of these radio relay systems, interface parts may be integrated with other systems and therefore standard interfaces are not required under these circumstances. The manufacturer shall declare whether a standard interface is provided or not.

For conformance testing of Class A equipment, a baseband interface at points Z, Z' of the block diagram in figure 1 which complies to one of the ETSI recognized standard interfaces (e.g. ITU-T Recommendation G.703 [8]) shall be made available.

4.5 System block diagram

The system block diagram is shown in figure 1.

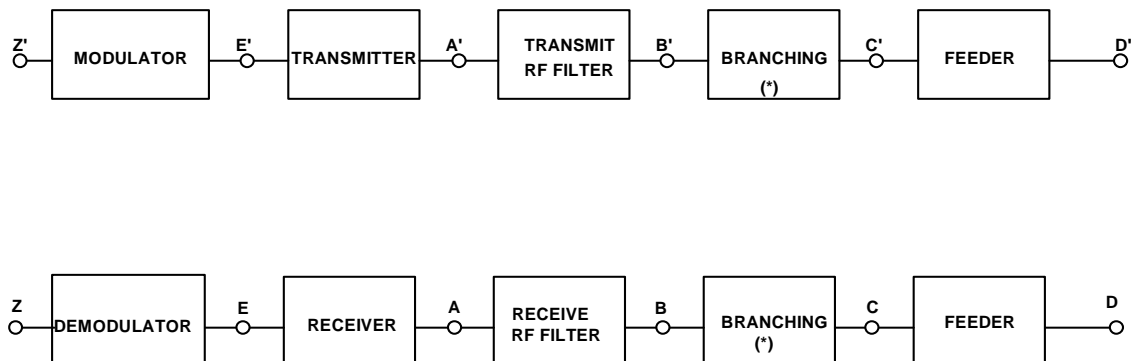

(*) NO FILTERING INCLUDED

NOTE 1: For the purpose of defining the measurement points, the branching network does not include a hybrid.

NOTE 2: The points shown above are reference points only; points C and C', D and D' in general coincide.

NOTE 3: Points B and C, B' and C' may coincide when simple duplexer is used.

NOTE 4: In case of TDD systems points B, B', A and A' may coincide

Figure 1: System block diagram

4.6 Antennas and RF-interface

4.6.1 Antenna Requirements

Requirements for the co-polar antenna radiation pattern envelope are given figure 7a) (Range 6, Class 1) in EN 300 833 [13]. However, cross-polar radiation pattern requirements are not relevant for the systems using this frequency band.

4.6.2 RF interface

An adaptor from point D or D' to IEC standard flange shall be made available by the manufacturer for transmit power, RF-spectrum and spurious emission measurements.

4.7 Power supply

The equipment shall operate from any of the primary supplies within the ranges specified in ETS 300 132-1 [1] and ETS 300 132-2 [2].

NOTE: Some applications may require voltages that are not covered by ETS 300 132-1 [1] and ETS 300 132-2 [2] (e.g. 12 V and / or 24 V).

5 Parameters for digital systems

5.1 Transmission capacity

The manufacturer shall declare the transmission capacities and the channel spacing used. With all transmission capacities the relevant spectrum mask shall be conformed to.

5.2 Error-performance and availability requirements for Class A equipment

Class A equipment shall be designed in order to meet network error-performance and availability requirements foreseen by ITU-T Recommendation G.826 [11], following the criteria defined in ITU-R Recommendations F.1189 [12], F.697 [14] and F.ANPER [7] for the short haul or the access part of the national portion of the digital connection

The interference limit specified in subclause 4.1.3.2, rather than the actual threshold of the equipment, should be considered, when planning the hop length for the required fade margin due to propagation effects.

It should be noted that the specified channel selection procedure (see subclause 4.1.3) can help to avoid interference situations between Class A equipment but cannot guarantee interference-free operation in all situations (see note).

The frequency agility, described in subclause 4.1.3.3, may be a useful function in interference avoidance e.g. between systems using different duplexing methods or between Class A and Class B –systems.

NOTE: Interference power level in existing network receivers can be in the worst case:

$$-71\text{dBm} - P_{\text{tx}} (\text{dBm}) + 10 \log(\text{BW}/10\text{MHz}).$$

where:

- P_{tx} is the mean transmit power of the radio relay at the reference point D' given in the figure 1;
- BW is the noise bandwidth of the receiver.

The interference value calculated from the equation simulates the interference effect of a continuous signal. However, the true effect of a bursty signal may be approximately 3 dB higher (with 50 % duty cycle).

5.3 Transmitter characteristics

5.3.1 Transmitter power

5.3.1.1 Transmitter power range

The transmit power shall not exceed -20 dBW referred to point D' in the system block diagram given in figure 1. For continuous signals the average power shall be measured. For burst type signals (e.g.TDD) the average power during the signal burst shall be measured.

5.3.1.2 Equivalent Isotropically Radiated Power (EIRP)

The Equivalent Isotropically Radiated Power (EIRP) shall be limited to 15 dBW.

5.3.2 Radiated Spectrum

5.3.2.1 RF spectrum mask

The spectrum mask for 100 MHz radio channels is shown in figure 2a and for 50 MHz channels in figure 2b. The RF-frequency instability allowance is not included in the masks. The related spectrum analyser settings are given in table 1.

Spectrum mask requirement shall be fulfilled with all baseband alternatives applied. In cases of PDH baseband interfaces, the test signal in accordance with ITU-T Recommendation O.151 [19] shall be used.

Table 1: Spectrum analyzer settings for RF power spectrum measurements

Channel spacing	MHz	100	50
Centre Frequency		Actual	Actual
Sweep width	MHz	250/500	150/250
Scan time	s	5	5
IF bandwidth	kHz	100	100
Video bandwidth	kHz	3	3

5.3.2.2 Spurious emissions

According to ITU-R Recommendation F.1191 [10] and CEPT/ERC Recommendation 74-01 [9], the external spurious emissions are defined as emissions at frequencies which are outside the nominal carrier frequency more than 250 % of the relevant channel separation.

The limits of these emissions, which apply at reference point C', shall conform to CEPT/ERC Recommendation 74-01 [9].

5.3.3 Radio frequency tolerance

The maximum allowable RF frequency tolerance from the nominal carrier frequencies shall not exceed ± 50 ppm. This limit includes both short-term factors (environmental effects) and long-term ageing effects. The manufacturer shall declare the values of the nominal carrier frequencies.

In the type test the manufacturer shall state the guaranteed short-term part and the expected ageing part.

5.4 Receiver characteristics

5.4.1 Spurious emissions

Refer to subclause 5.3.2.2. Spurious emission requirements shall apply at the reference point C.

6 Parameters for wideband analogue systems

6.1 Transmitter characteristics

6.1.1 Power

6.1.1.1 Transmitter power range

The mean transmit power shall not exceed -20 dBW as referred to point D' in the system block diagram given in figure 1.

6.1.1.2 EIRP

The Equivalent Isotropically Radiated Power (EIRP) shall be limited to 15 dBW.

6.1.2 Radiated spectrum

6.1.2.1 Spectrum mask

The spectrum masks are shown in figures 2a and 2b respectively for 100 MHz channels and 50 MHz channels.

The RF-frequency instability allowance is not included in the spectrum masks. The recommended spectrum analyser settings for measuring the RF spectrum mask detailed in figures 2a and 2b are showed in table 1.

6.1.2.2 Spurious emissions

Refer to subclause 5.3.2.2.

6.1.3 RF frequency tolerance

The maximum allowable RF frequency tolerance shall not exceed, ± 200 ppm. This limit includes both short-term factors (environmental effects) and long-term ageing effects. The manufacturer shall declare the values of the nominal carrier frequencies. In the type test the manufacturer shall state the guaranteed short-term part and the expected ageing part.

6.2 Receiver characteristics, spurious emissions

Refer to subclause 5.4.1.

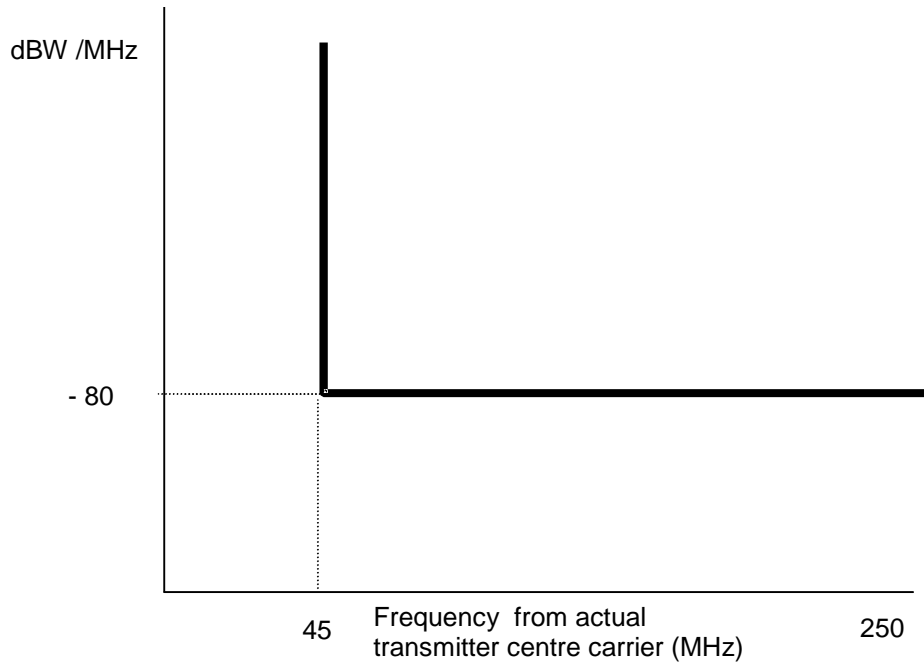

Figure 2a: Limits of spectral power density for 100MHz radio channels

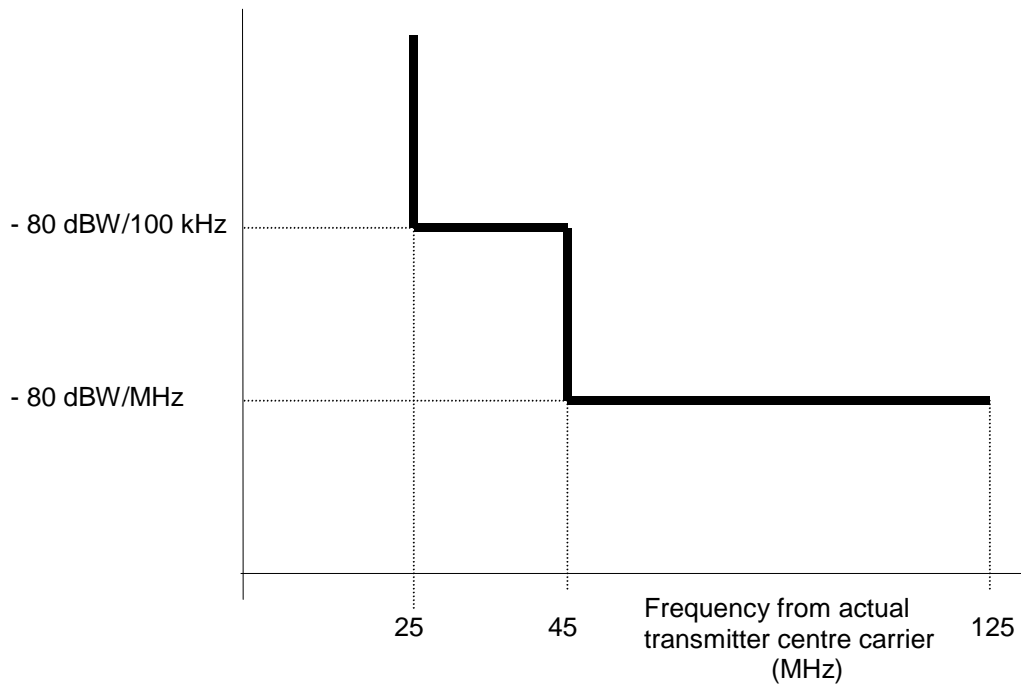

Figure 2b: Limits of spectral power density for 50 MHz radio channels

Annex A (informative): Additional information

A.1 Additional information on Class A and Class B

Class A equipment, with higher performance and availability requirements as referred to in subclause 5.2, cannot share spectrum with Class B equipment using FDD or TDD without a Channel selection procedure-see subclause 4.1.3. Regulators may restrict both Classes to their own separately defined sub-bands.

A.2 Radio frequency channel arrangement

The relevant radio frequency channel arrangement provided by CEPT Recommendation 12-09 [5]; however, for reader's convenience, the figure below gives its general overview:

Occupied spectrum: 57 to 59 GHz Band

a) 100 MHz channels

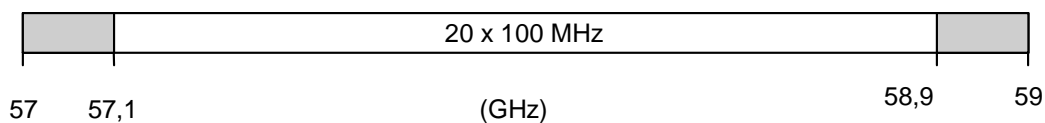

b) 50 MHz channels

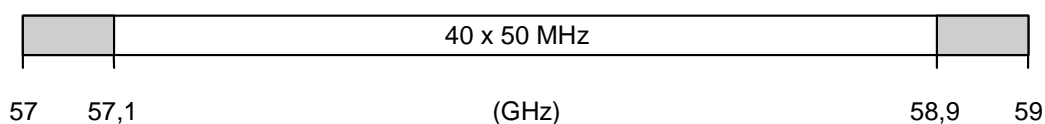

Figure A.2: Radio frequency channel arrangement

Let:

f_r be the reference frequency of 56 950 MHz;

f_n be the centre frequency of a radio-frequency channel in the band 57 GHz to 59 GHz;

then the centre frequencies of individual channels are expressed by the following relationships:

a) for systems with a channel separation of 100 MHz:

$$- f_n = f_r + 100 n \text{ MHz};$$

where:

$$- n = 1, 2, 3, \dots, 20.$$

b) for systems with a channel separation of 50 MHz:

- $f_n = f_r + 25 + 50 n$ MHz;

where:

- $n = 1, 2, 3, \dots, 40$.

Channels within the frequency ranges 57 GHz to 57,100 GHz and 58,900 GHz to 59 GHz should not be used for traffic, until satisfactory coexistence studies with Fixed Service in adjacent bands are completed; these channels could be used for equipment alignment and propagation tests.

A.3 Antenna alignment procedures

The RF-channel selection procedure specified in subclause 4.1.3 requires that new systems should not start to transmit at "occupied" channels. This requirement shall be respected also during the antenna alignment in order to avoid possible interferences to other systems. The following methods could be used for the antenna alignment without disturbing the existing transmission (examples only):

- use of band edge channels 57 GHz to 57,1 GHz and 58,9 GHz to 59 GHz which are dedicated by CEPT/ERC Recommendation 12-09 for equipment alignment and propagation tests for "normal" antenna alignment procedure;
- use of optical viewfinder, which is applicable for hops up to about 500 metres. Rough alignment by optical means is always necessary;
- more sophisticated procedures may use, after optical alignment, interference measurement results at both ends and transmit test signal one end at the time using the detected unoccupied channels. Receiving end could sweep the possible channels one by one to detect the signalling tone and use the level of it for the alignment indication. Separate communications means such as mobile phones could also be used to simplify the procedure.

Annex B (normative): Essential requirements for the EC Council Directive 89/336 (EMC Directive)

The clauses of the present document, reported in table B.1, are relevant for the EC directive [89/336].

Table B.1: Subclauses of the present document relevant for compliance with the essential requirements of the EC Council Directive 89/336

Clause/ subclause number, or annex reference	Title	Corresponding article of Council Directive 89/336/EEC [20]	Qualifying remarks
	Spurious emission tests:		
5.3.2.2	Spurious emissions (transmitter, digital systems)	4(a)	
5.4.3	Spurious emissions (receiver, digital systems)	4(a)	
6.2.2.2	Spurious emissions (transmitter, analogue systems)	4(a)	
6.3	Receiver characteristics, spurious emissions (analogue systems)	4(a)	
4.1.3.2	Interference avoidance requirements	4(a)	

NOTE: During the process of the agreement against the EMC-directive a test shall be provided with the RF-channel selection procedure being into operation to verify that the equipment comply with relevant EMC-requirements.

Annex C (normative): System type codes for regulatory procedures

System types reported in the present document, shall be identified with the codes reported in table C.1.

Table C.1: System type codes for radio equipment reported in the present document, relevant to regulatory procedures

System type codes	Equipment Class	Channel spacing	System type
01	Class A	50 MHz	Digital
02	Class A	100 MHz	Digital
03	Class B	50 MHz	Digital
04	Class B	100 MHz	Digital
05	Class B	50 MHz	Analogue
06	Class B	100MHz	Analogue
Class A: Digital equipment for high density fixed service (HDFS) applications typically connected to public networks, which apply the RF-channel selection procedure (see subclause 4.1.3). Class B: Equipment without requirements for quality of service.			

Annex D (informative): Rationale for the interference limit formula

D.1 Analysis of the quality value for the channel selection procedure

D.1.1 Theoretical background

The channel selection procedure targets to ensure required quality of service of 58 GHz radio links connected to public switched networks. The principle of channel selection procedure is that Class A 58 GHz radio links do not start to transmit on a channel when that channel is already in use. This would ensure continued operation of various kinds of radio links.

The channel use can be detected if the received interference power I clearly exceed the noise power. The receiver noise power is given by $N_0 NF B$ where B is the bandwidth of the interference measurement, NF is the noise figure, and $N_0=kT$. The transmission is allowed when/

$$- I/B < M N_0 NF, \quad (1)$$

where M is the necessary margin and the noise power density N_0 . A reasonable channel use threshold is, therefore/

$$- (I/B)_{\text{threshold}} = M N_0 NF. \quad (2)$$

The suggested threshold value for various kinds of systems is -151 dBm/Hz (-81dBm/10MHz). It can be obtained taking noise figure (NF) 18dB and margin of 5 dB or other combination of the two. This threshold has been agreed as the reference for the interference limit formula in subclause 4.1.3.2.1. See figure below for the breakdown of the margin M .

In order to avoid conflict situations, it is necessary that the interference is measured from the whole transmission bandwidth before transmission is initiated.

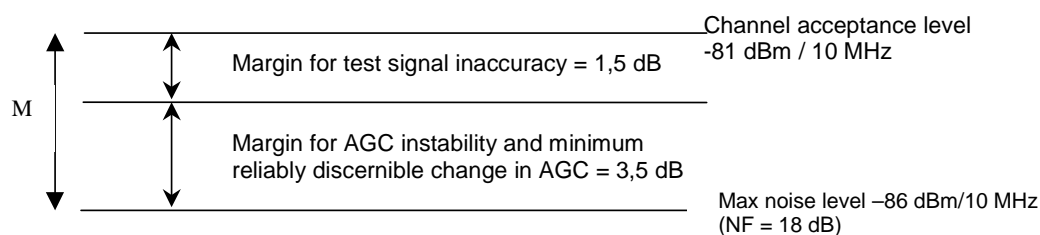

Figure 1A

D.1.2 Typical co-channel interference situation when channel rejection threshold is used

The interference level measured by a radio is generally caused by many interfering radios, but in a typical situation one interferer dominates. Therefore, we concentrate on studying the system of two radios belonging to different hops shown in figure D.1B. Radio 0 is transmitting at power P_0 and has signal bandwidth B_0 . Its antenna gain in the direction of the interfering radio 1 is $G_0(\theta_0)$. The corresponding values for radio 1 are P_1 , B_1 , and $G_1(\theta_1)$. The interference power measured in radio 0 on bandwidth B_0 , caused by radio 1, is I_0 and the interference power measured by radio 1, caused by radio 0, is I_1 .

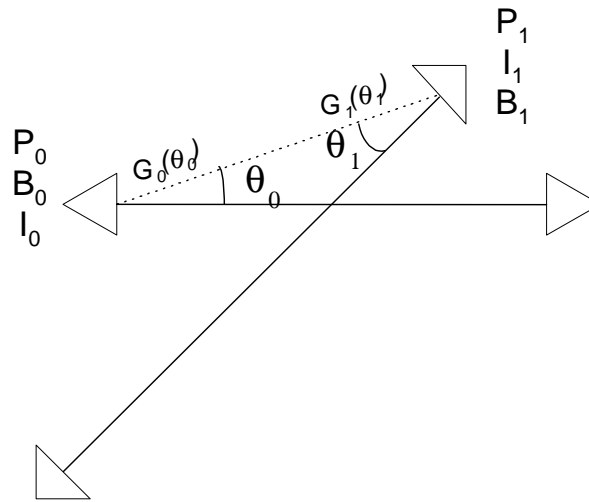

Figure 1B: A configuration of two interfering links

Assuming that receiver bandwidth is approximately equal to transmit signal bandwidth, and assuming that $B_1 > B_0$, we write the interference powers as:

- $I_0 = (B_0/B_1)P_1G_0(\theta_0)G_1(\theta_1)A_{12}$.
- $I_1 = P_0G_1(\theta_1)G_0(\theta_0)A_{12}$ (3)

where A_{12} is the attenuation. On the other hand, if $B_1 < B_0$, we have:

- $I_0 = P_1G_0(\theta_0)G_1(\theta_1)A_{12}$.
- $I_1 = (B_1/B_0)P_0G_1(\theta_1)G_0(\theta_0)A_{12}$. (4)

When the common factors $G_0(\theta_0)$, $G_1(\theta_1)$, and A_{12} are eliminated from the two equations in (3) we get the relation:

- $P_1I_1/B_1 = P_0I_0/B_0$. (5)

The same equation is found if the common factors are eliminated from the two equations in (4). Thus the antenna gains are of no concern.

If the most recently installed radio system 1 asserts the following condition:

- $I_1/B_1 < (I/B)_{\text{threshold}}$, (6)

we obtain, by using equation (6), for the interference caused to the previously existing system 0:

- $I_0/B_0 < (P_1/P_0) (I/B)_{\text{threshold}}$. (7)

This indicates that the use of the channel selection threshold guarantees that the interference generated to existing radio systems is limited by equation (7).

D.2 Protection capability of the RF-channel selection procedure

RF-channel selection procedure specifies the maximum interference level of an unoccupied channel which defines the hop length rather than the noise limit. The procedure helps, however, to avoid interference situations between systems with different parameters such as transmit power or spectrum width. The procedure guarantees interference free operation for systems with relatively simple modulation methods typically up to about 500 metres. Longer hops are protected with high probability if the RF-channel with the lowest measured interference power is always selected during the procedure.

The channel selection procedure does not always protect against the adjacent channel interference when there is large difference in out-of-band spectrum of the existing system and the new system and if the distance to the interferer is fairly short.

The interference situations between systems with different duplex methods cannot be always avoided. Interferences from FDD-type systems into TDD-type systems can be avoided if the procedure is applied according to the standard in both systems. However, the procedure cannot guarantee interference free situation for FDD-type systems because duplex-frequency is not standardized. For this reason the concept of "frequency agility" was specified (see subclause 4.1.3.3). This method may also help to avoid long outages due to interference situations between Class A and Class B systems.

D.3 Frequency agility criteria

A means to implement criteria for the detection of unacceptable interference could be the following:

- unacceptable interference situation (corresponding to unavailability situation) is decided if during 10 consecutive seconds or more the estimated BER evaluated by an in-service proprietary method, with a level of confidence of 99 %, exceeds 10^{-3} and the actual received signal level is more than 5 dB above the receiver threshold level corresponding to $BER = 10^{-3}$. For conformance testing purposes this receiver threshold level shall be declared by the manufacturer. If available, the new RF-channel shall be operational again within the time declared by the manufacturer.

Bibliography

The following material, though not specifically referenced in the body of the present document (or not publicly available), gives supporting information.

- ITU-R Recommendation P.530: "Propagation data and prediction methods required for the design of terrestrial line-of-sight systems".
- ITU-R Recommendation F.1102: "Characteristics of radio-relay systems operating in frequency bands above about 17 GHz".

History

Document history		
Edition 1	March 1996	Publication as ETS 300 408
V1.2.1	March 2000	One-step Approval Procedure OAP 20000707: 2000-03-08 to 2000-07-07
V1.2.1	September 2000	Publication