

Final draft **ETSI EN 300 403-2** V1.3.1 (2000-08)

---

*European Standard (Telecommunications series)*

**Integrated Services Digital Network (ISDN);  
Digital Subscriber Signalling System No. one (DSS1) protocol;  
Signalling network layer for circuit-mode basic call control;  
Part 2: Specification and Description  
Language (SDL) diagrams**

---



---

**Reference**

REN/SPAN-05210-2

---

**Keywords**

ISDN, DSS1, layer 3, SDL

**ETSI**

---

650 Route des Lucioles  
F-06921 Sophia Antipolis Cedex - FRANCE

Tel.: +33 4 92 94 42 00 Fax: +33 4 93 65 47 16

Siret N° 348 623 562 00017 - NAF 742 C  
Association à but non lucratif enregistrée à la  
Sous-Préfecture de Grasse (06) N° 7803/88

---

**Important notice**

Individual copies of the present document can be downloaded from:

<http://www.etsi.org>

The present document may be made available in more than one electronic version or in print. In any case of existing or perceived difference in contents between such versions, the reference version is the Portable Document Format (PDF). In case of dispute, the reference shall be the printing on ETSI printers of the PDF version kept on a specific network drive within ETSI Secretariat.

Users of the present document should be aware that the document may be subject to revision or change of status. Information on the current status of this and other ETSI documents is available at <http://www.etsi.org/tb/status/>

If you find errors in the present document, send your comment to:  
editor@etsi.fr

---

**Copyright Notification**

No part may be reproduced except as authorized by written permission.  
The copyright and the foregoing restriction extend to reproduction in all media.

© European Telecommunications Standards Institute 2000.  
All rights reserved.

# Contents

Intellectual Property Rights .....	4
Foreword.....	4
1 Scope .....	5
2 References .....	5
3 Definitions, symbols and abbreviations .....	6
3.1 Definitions .....	6
3.2 Symbols.....	7
3.3 Abbreviations .....	7
4 User side and network side call states .....	8
5 Network side SDL diagrams - overview .....	9
5.1 Call states .....	9
5.2 Block diagram .....	9
5.3 List of primitives .....	10
5.4 Representation method .....	10
6 User side SDL diagrams - overview.....	13
6.1 Call states .....	13
6.2 Block diagram .....	13
6.3 List of primitives .....	14
6.4 Representation method .....	14
7 Restart SDL diagrams - overview .....	14
7.1 States related to the restart procedure.....	14
7.2 Block diagram .....	15
7.3 List of primitives exchanged with system management.....	15
7.4 Representation method .....	15
8 Graphical SDL diagrams .....	16
8.1 Network side SDL diagrams .....	17
8.2 User side SDL diagrams.....	102
8.3 Restart SDL diagrams .....	158
<b>Annex A (informative): Relevant differences to ETS 300 102-2.....</b>	<b>166</b>
A.1 Structural changes .....	166
A.2 Technical changes .....	167
History .....	168

---

## Intellectual Property Rights

IPRs essential or potentially essential to the present document may have been declared to ETSI. The information pertaining to these essential IPRs, if any, is publicly available for **ETSI members and non-members**, and can be found in ETSI SR 000 314: "*Intellectual Property Rights (IPRs); Essential, or potentially Essential, IPRs notified to ETSI in respect of ETSI standards*", which is available from the ETSI Secretariat. Latest updates are available on the ETSI Web server (<http://www.etsi.org/ipr>).

Pursuant to the ETSI IPR Policy, no investigation, including IPR searches, has been carried out by ETSI. No guarantee can be given as to the existence of other IPRs not referenced in ETSI SR 000 314 (or the updates on the ETSI Web server) which are, or may be, or may become, essential to the present document.

---

## Foreword

This European Standard (Telecommunications series) has been produced by ETSI Technical Committee Services and Protocols for Advanced Networks (SPAN), and is now submitted for the Vote phase of the ETSI standards Two-step Approval Procedure.

The present document which is based on ITU-T Recommendation Q.931 (1993) [7] is an extended and updated version of ETS 300 102-2 (1990) which was based on CCITT Recommendation Q.931 (1988). Annex A identifies the relevant differences between the present document and ETS 300 102-2.

The present document is part 2 of a multi-part standard covering the Digital Subscriber Signalling System No. one (DSS1) protocol specification for the Integrated Services Digital Network (ISDN) signalling network layer for circuit-mode basic call control, as described below:

- Part 1: "Protocol specification [ITU-T Recommendation Q.931 (1993), modified]";
- Part 2: "Specification and Description Language (SDL) diagrams";**
- Part 3: "Protocol Implementation Conformance Statement (PICS) proforma specification";
- Part 4: "Test Suite Structure and Test Purposes (TSS&TP) specification for the user";
- Part 5: "Abstract Test Suite (ATS) and partial Protocol Implementation eXtra Information for Testing (PIXIT) proforma specification for the user";
- Part 6: "Test Suite Structure and Test Purposes (TSS&TP) specification for the network";
- Part 7: "Abstract Test Suite (ATS) and partial Protocol Implementation eXtra Information for Testing (PIXIT) proforma specification for the network".

<b>Proposed national transposition dates</b>	
Date of latest announcement of this EN (doa):	3 months after ETSI publication
Date of latest publication of new National Standard or endorsement of this EN (dop/e):	6 months after doa
Date of withdrawal of any conflicting National Standard (dow):	6 months after doa

---

# 1 Scope

The present document specifies the stage three of circuit-mode on-demand basic telecommunication services for the pan-European Integrated Services Digital Network (ISDN) as provided by European telecommunications operators at the T reference point or coincident S and T reference point (as defined in ITU-T Recommendation I.411 [3]) by means of the Digital Subscriber Signalling System No. one (DSS1). Stage three identifies the protocol procedures and switching functions needed to support a telecommunication service (see CCITT Recommendation I.130 [2]).

In addition, the present document specifies the protocol requirements at the T reference point where the service is provided to the user via a private ISDN.

NOTE 1: Procedures at the T reference point, to support the access of a private ISDN to the public ISDN, are not explicitly identified in the present document, however some procedures are applicable only to the T reference point.

The present document does not specify the additional protocol requirements where the service is provided to the user via a telecommunication network that is not an ISDN.

The present document is specified using the Specification and Description Language (SDL) as specified in CCITT Recommendation Z.100 [4].

In order to describe the point-to-multipoint operation of the protocol, the concept of a "global" process running in parallel with a number of "individual" (dynamic) processes has been introduced. This approach, and the associated definition of internal primitives is intended to provide a coherent description of the protocol and does not constrain implementations. The SDL diagrams in this part, and the text of clause 5 of ETS 300 403-1 [1], together provide a complete specification of the protocol within the scope of the present document.

A basic telecommunication service is a fundamental type of service. It forms the basis on which supplementary services may be added.

NOTE 2: Specific requirements of individual circuit-mode basic telecommunication services are not covered in the present document. However, ETR 018 [5] gives guidance on the use of service specific information elements to implement individual basic telecommunication services.

The method of testing of the present document is common with that for ETS 300 403-1 [1]. Further parts of the present document specify the method of testing and detailed application specific requirements to determine conformance based on the present document.

The present document is applicable to equipment supporting circuit-mode on-demand basic telecommunication services, to be attached at either side of a T reference point or coincident S and T reference point when used as an access to the public ISDN.

---

# 2 References

The following documents contain provisions which, through reference in this text, constitute provisions of the present document.

- References are either specific (identified by date of publication, edition number, version number, etc.) or non-specific.
- For a specific reference, subsequent revisions do not apply.
- For a non-specific reference, the latest version applies.
- A non-specific reference to an ETS shall also be taken to refer to later versions published as an EN with the same number.

[1] ETSI ETS 300 403-1 (1995): "Integrated Services Digital Network (ISDN); Digital Subscriber Signalling System No. one (DSS1) protocol; Signalling network layer for circuit-mode basic call control; Part 1: Protocol specification [ITU-T Recommendation Q.931 (1993), modified]".

- [2] CCITT Recommendation I.130 (1988): "Method for the characterization of telecommunication services supported by an ISDN and network capabilities of an ISDN".
- [3] ITU-T Recommendation I.411 (1993): "ISDN user-network interfaces - Reference configurations".
- [4] CCITT Recommendation Z.100 (1988): "Specification and description language (SDL)".
- [5] ETSI ETR 018: "Integrated Services Digital Network (ISDN); Application of the Bearer Capability (BC), High Layer Compatibility (HLC) and Low Layer Compatibility (LLC) information elements by terminals supporting ISDN services".
- [6] ETSI ETS 300 102-2: "Integrated Services Digital Network (ISDN); User-network interface layer 3; Specifications for basic call control; Specification Description Language (SDL) diagrams".
- [7] ITU-T Recommendation Q.931: "SDN user-network interface layer 3 specification for basic call control".

---

## 3 Definitions, symbols and abbreviations

### 3.1 Definitions

For the purposes of the present document, the following terms and definitions apply in addition to those given in ETS 300 403-1 [1]:

**point-to-multipoint configuration; multipoint terminal configuration; multipoint configuration:** terminal configuration in which there is more than one signalling entity











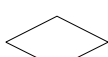

**point-to-multipoint data link; broadcast data link:** data link connection with the capability to support more than two connection endpoints

**point-to-point configuration; single-point terminal configuration; single-point configuration:** terminal configuration in which there is one signalling entity

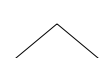
**point-to-point data link:** data link on which a frame is directed to a single endpoint

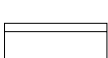
## 3.2 Symbols

For the purposes of the present document, the following symbols apply. A full description of the symbols and their meaning and application is given in CCITT Recommendation Z.100 [4].

	State symbol
	Input symbol (event occurrence)
	Output symbol (signal generation which will lead to an associated event occurrence)
	Save symbol (save event until completion of a transition)
	Task symbol
	Decision symbol
	Procedure call symbol
	Transition option symbol (implementation option)
	Procedure start symbol
	Procedure return symbol
	Create request symbol (used to initiate an individual network side transaction)
	Stop symbol (used to end an individual network side transaction)
	Connection symbol
	Used mark (an input which is local to the layer 3 entity and which is required as a result of the representation approach adopted)

## 3.3 Abbreviations

For the purposes of the present document, the following abbreviations apply:

CES	Connection Endpoint Suffix
DSS1	Digital Subscriber Signalling System No. one
ISDN	Integrated Services Digital Network
SDL	Specification and Description Language

## 4 User side and network side call states

Table 1 shows which call states are applicable at the user and network sides during the various phases of a call.

**Table 1: Call states**

Call phase	Call state	User	Network
IDLE	Null	U0	N0
OUTGOING CALL (from user)	Call initiated Overlap sending Outgoing call proceeding Call delivered	U1 U2 U3 U4	N1 N2 N3 N4
INCOMING CALL (to user)	Call present Overlap receiving Incoming call proceeding Call received Connect request	U6 U25 U9 U7 U8	N6 N25 N9 N7 N8
ACTIVE	Active	U10	N10
CALL CLEARING	Disconnect request (clearing by the user) Disconnect indication (clearing by the network) Release request Call abort	U11 U12 U19 -	N11 N12 N19 N22
CALL SUSPEND/ RESUME	Suspend request Resume request	U15 U17	N15 N17
RESTART PROCEDURE (note)	Restart null Restart request Restart	REST0 REST1 REST2	REST0 REST1 REST2
NOTE:	These states relate to global call references and are applicable when the restart procedures are used. They may exist in both user and network sides.		



## 5 Network side SDL diagrams - overview

### 5.1 Call states

Table 2: Network side call states

Call state	Name
N0	Null
N1	Call initiated
N2	Overlap sending
N3	Outgoing call proceeding
N4	Call delivered
N6	Call present
N7	Call received
N8	Connect request
N9	Incoming call proceeding
N10	Active
N11	Disconnect request
N12	Disconnect indication
N15	Suspend request
N17	Resume request
N19	Release request
N22	Call abort
N25	Overlap receiving

NOTE 1: Network side timers, and the states in which they run, are specified in clause 9 of ETS 300 403-1 [1].  
 NOTE 2: Events in each state which lead to normal call establishment and clearing are marked with the "+" symbol.  
 NOTE 3: The primitives which pass to and from the call control block are shown for guidance only and are not fully specified.  
 NOTE 4: Internal primitives are marked by "\*\*\*". These are a result of the representation method that has been adopted.

### 5.2 Block diagram

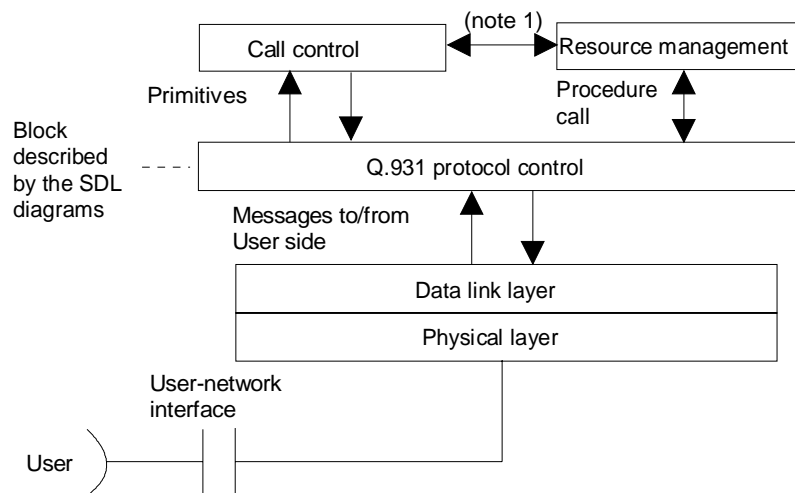

NOTE 1: Interface not described in the SDL diagrams.

NOTE 2: Control of B-channels is described in these SDL diagrams as part of the Q.931 protocol block.

Figure 1: Block diagram for the network side

## 5.3 List of primitives

Table 3: List of primitives

From call control block	To call control block
ALERTING REQUEST	ALERTING INDICATION
DISCONNECT REQUEST	CONNECT INDICATION
INFO REQUEST	DISCONNECT INDICATION
MORE INFO REQUEST	INFO INDICATION
NOTIFY REQUEST	MORE INFO INDICATION
PROCEEDING REQUEST	NOTIFY INDICATION
PROGRESS REQUEST	PROCEEDING INDICATION
REJECT REQUEST	PROGRESS INDICATION
RELEASE REQUEST	RELEASE CONFIRM
RESUME REJECT REQUEST	RELEASE INDICATION
RESUME RESPONSE	RESUME INDICATION
SETUP COMPLETE REQUEST	SETUP CONFIRM
SETUP REQUEST	SETUP INDICATION
SETUP RESPONSE	STATUS INDICATION
STATUS ENQUIRY REQUEST	SUSPEND INDICATION
SUSPEND REJECT REQUEST	TIMEOUT INDICATION
SUSPEND RESPONSE	RESTART CONFIRM (note 2)
RESTART REQUEST (note 1)	
NOTE 1: This primitive may be received from global call reference control.	
NOTE 2: This primitive is sent to global call reference control.	

## 5.4 Representation method

In order to describe the point-to-multipoint operation of the protocol, the concept of a "global" process running in parallel with a number of "individual" (dynamic) processes in the network side has been introduced. This approach, and the associated definition of internal primitives, is intended to provide a coherent description of the protocol and does not constrain implementation. The textual description in clause 5 of ETS 300 403-1 [1] is definitive.

Individual processes are used to track the responses of each terminal. The global (controlling) process runs in parallel with the (dynamically created/destroyed) individual process.

The global and individual processes communicate by means of internal primitives. These are related to layer 3 messages types and are defined in table 4. The internal primitives represent instantaneous actions. Thus, there is no possibility of errors caused by the crossover of primitives.

The global process maintains a list of recorded Connection Endpoint Suffix (CES) values to enable it to manage the individual processes. In this representation the global process also keeps a record of the state of the individual process associated with each responding terminal. Additionally a "preselected" CES is recorded when one terminal responds with a CONNECT message and this becomes the "selected" CES when the terminal is awarded the call.

This solution is compatible with point-to-point configurations. In this case the global process never creates any individual processes, and the timers defined in ETS 300 403-1 [1] for the relevant states are handled by the global process, including timer T322 which may run in any state except the Null state. Also, ever since a transition to the Null state occurs, the stopping of this timer (if running) should be regarded as an implicit statement, as it is not shown in order not to extend the SDL representation.

In a point-to-multipoint configuration, individual processes may exist in the following states:

- N0 Null (processes are created in this state);
- N7 Call received;
- N8 Connect request;
- N9 Incoming call proceeding;
- N19 Release request;
- N25 Overlap receiving.

Two sets of SDL diagrams are required for these states to show the global and individual processes.

The global process handles all communications with call control. Messages from individual terminals are sent to the individual process for that terminal if one exists (i.e. if the CES is recognized). Messages with an unrecognized CES are passed to the global process. Messages with the selected CES are also sent to the global process.

In a point-to-multipoint configuration, the handling of the timers defined in ETS 300 403-1 [1] has been done according to the following principles:

- a) timers T301 and T310 only run in the global process when an incoming call is being offered;
- b) timers T304, T308 and T322 only run in the individual processes when an incoming call is being offered. The stopping of timer T322 (if running) when an individual process is destroyed should be regarded as an implicit statement as it is not shown in order not to extend the SDL representation;
- c) in the other phases of a call, the timers associated with each state, as well as timer T322 which may run in any state except the Null state, are all handled by the global process. Once again, the stopping of this timer (if running) should be regarded as an implicit statement because it extends the SDL representation.

**Table 4: Network side layer 3 internal primitives**

Primitive name	From	To	Meaning
INT. ALERTING REQ INT. CONNECT REQ INT. CALL PROC REQ INT. SETUP ACK REQ	Global	Individual	When global process receives ALERTING it starts an individual process and sends INT. ALERTING REQ to it (etc.)
INT. ALERTING IND INT. CONNECT IND INT. CALL PROC IND	Individual	Global	Sent on receipt of ALERTING (etc.)
END PROCESS	Global	Individual	Sent when the global process terminates an individual process
INT. RELEASE REQ	Global	Individual	Instructs individual process to release terminal (e.g. for releasing non-selected terminals)
INT. RELEASE IND	Individual	Global	Informs global process that a terminal has begun to release
INT. INFO REQ	Global	Individual	Sent on receipt of INFO REQ
INT. INFO IND	Individual	Global	Sent on receipt of INFO
INT. STAT. ENQ. REQ	Global	Individual	Sent on receipt of STATUS ENQUIRY REQ
INT. PROGRESS IND	Individual	Global	Sent on receipt of PROGRESS
INT. REL. COMP. IND	Individual	Global	Sent to indicate that the individual process has been cleared
NOTE:	The global process should not release the call reference until all individual processes have completed clearing.		

Figure 2 (an arrow diagram) shows an example of this representation method.

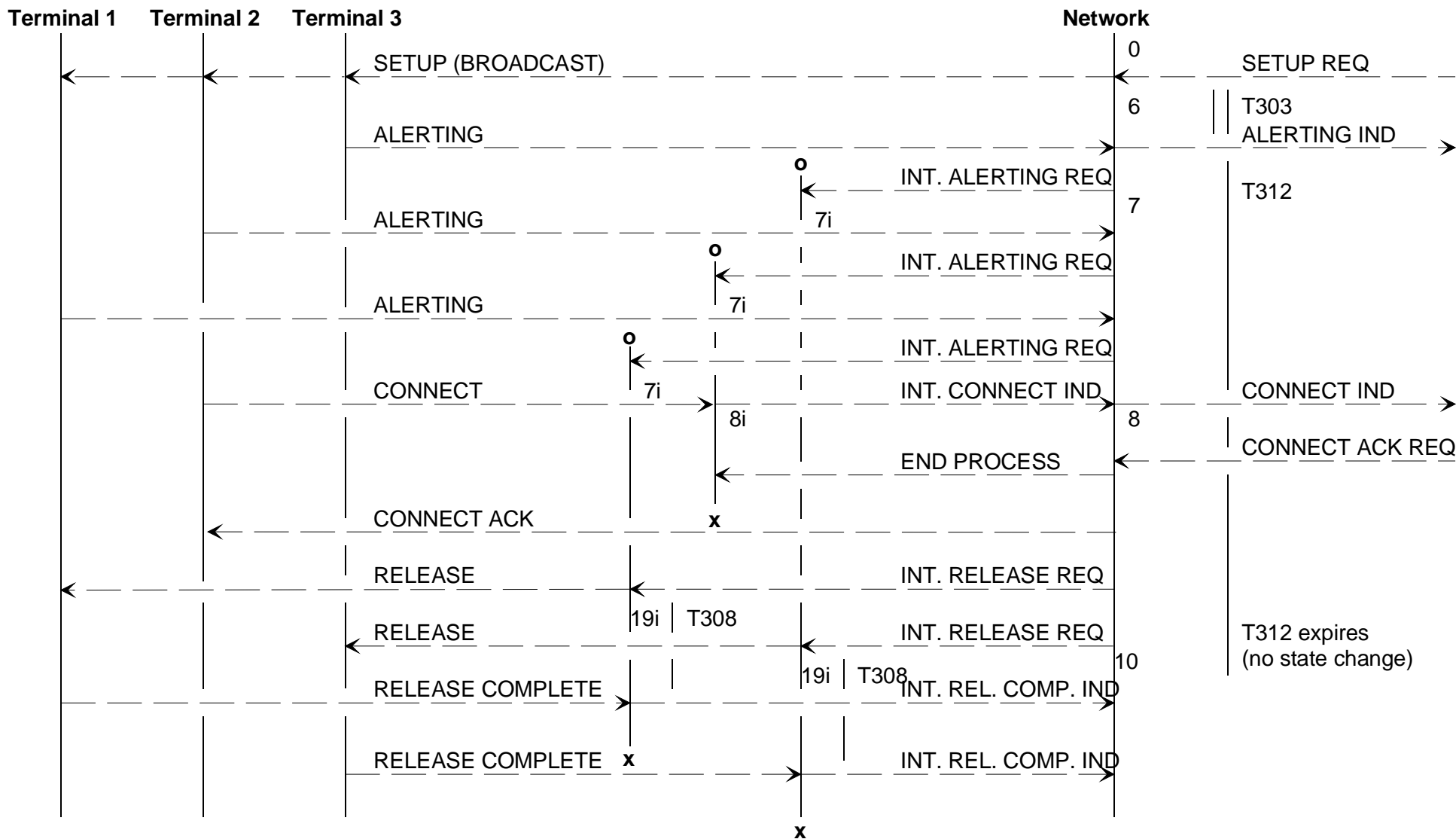

NOTE: o = creation of state machine, x = deletion of state machine; numbers indicate states of the state machines shown.

Figure 2: Multipoint call establishment (and clearing of non-selected terminals)

## 6 User side SDL diagrams - overview

### 6.1 Call states

**Table 5: User side call states**

Call state	Name
U0	Null
U1	Call initiated
U2	Overlap sending
U3	Outgoing call proceeding
U4	Call delivered
U6	Call present
U7	Call received
U8	Connect request
U9	Incoming call proceeding
U10	Active
U11	Disconnect request
U12	Disconnect indication
U15	Suspend request
U17	Resume request
U19	Release request
U25	Overlap receiving

NOTE 1: User side timers, and the states in which they run, are specified in clause 9 of ETS 300 403-1 [1].  
 NOTE 2: Events in each state which lead to normal call establishment/clearing are shown by the "+" symbol.  
 NOTE 3: Primitives passed to and from the call control (user application) block are shown for guidance only and are not fully specified.

### 6.2 Block diagram

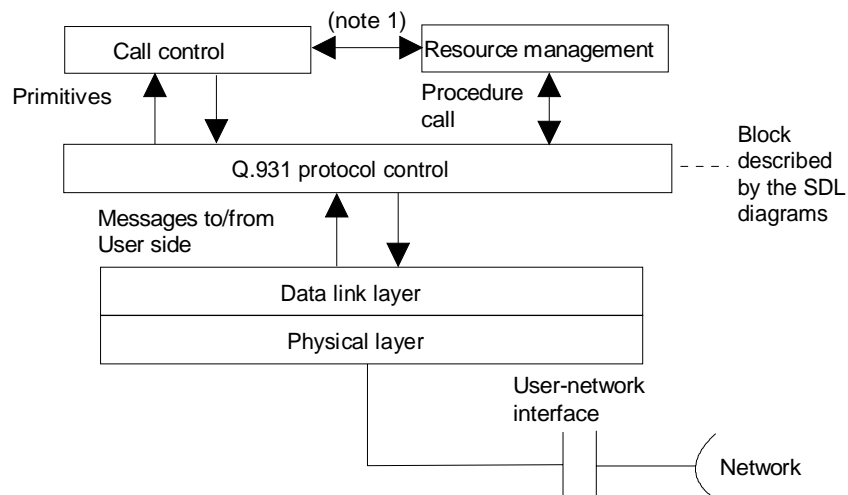

NOTE 1: Interface not described in the SDL diagrams.

NOTE 2: Control of B-channels is described in these SDL diagrams as part of the Q.931 protocol block.

**Figure 3: Block diagram for the user side**

## 6.3 List of primitives

**Table 6: List of primitives**

From call control block	To call control block
ALERTING REQUEST	ALERTING INDICATION
DISCONNECT REQUEST	DISCONNECT INDICATION
INFO REQUEST	INFO INDICATION
MORE INFO REQUEST	MORE INFO INDICATION
NOTIFY REQUEST	NOTIFY INDICATION
PROCEEDING REQUEST	PROCEEDING INDICATION
PROGRESS REQUEST	PROGRESS INDICATION
REJECT REQUEST	RELEASE CONFIRM
RELEASE REQUEST	RELEASE INDICATION
RESUME REQUEST (note 1)	RESUME CONFIRM
SETUP REQUEST	SETUP COMPLETE INDICATION
SETUP RESPONSE	SETUP CONFIRM
STATUS ENQUIRY REQUEST	SETUP INDICATION
SUSPEND REQUEST (note 1)	STATUS INDICATION
RESTART REQUEST (note 2)	SUSPEND CONFIRM
	RESTART CONFIRM (note 3)
NOTE 1: These primitives are not defined for a primary rate access, i.e. the use of the call rearrangement procedure is restricted to basic access.	
NOTE 2: This primitive may be received from global call reference control.	
NOTE 3: This primitive is sent to global call reference control.	

## 6.4 Representation method

The representation method of user side SDL diagrams has not followed the concept of a global process running in parallel with a number of individual processes, because from a signalling point of view only one call is handled by the global process at each time. Therefore, the global process never creates any individual processes, and only one set of SDL diagrams is required to represent the user side call states.

As a consequence, the timers associated with each state, as well as timer T322 which may run in any state except the Null state, are all handled by the global process. Also, as mentioned for the network side, the stopping of this timer (if running) should be regarded as an implicit statement because it extends the SDL representation.

---

## 7 Restart SDL diagrams - overview

### 7.1 States related to the restart procedure

**Table 7: States related to the restart procedure**

Call state	Name
REST0	Restart null
REST1	Restart request
REST2	Restart
NOTE 1: Timers related to the restart procedure, and the states in which they run, are specified in clause 9 of ETS 300 403-1 [1].	
NOTE 2: The primitives which pass to and from the system management block (see table 8) and the protocol control block (see tables 3 and 6) are shown for guidance only and are not fully specified.	

## 7.2 Block diagram

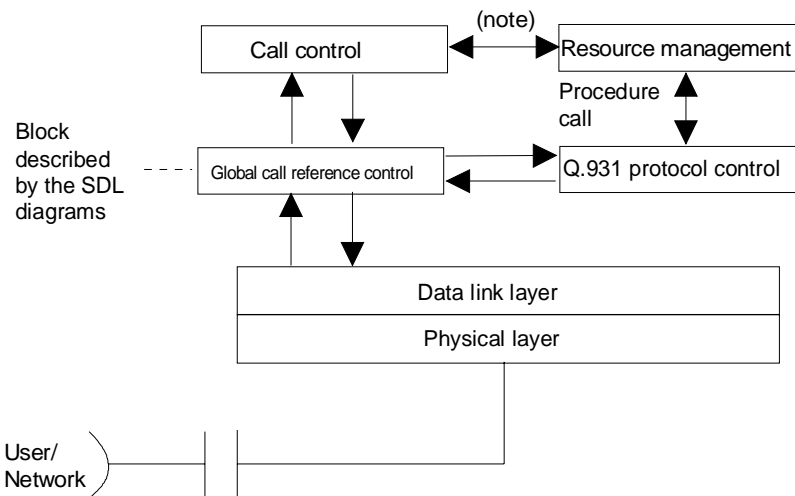

NOTE: Interface not described in the SDL diagrams.

**Figure 4: Block diagram for the restart procedure**

## 7.3 List of primitives exchanged with system management

**Table 8: List of primitives**

From system management block	To system management block
MANAGEMENT RESTART REQUEST	TIMEOUT MANAGEMENT INDICATION STATUS MANAGEMENT INDICATION MANAGEMENT RESTART CONFIRM
NOTE: Primitives related to the restart procedure which may be sent or received to/from protocol control block are already indicated in tables 3 and 6.	

## 7.4 Representation method

The representation method of the restart SDL diagrams follows the concept of a single finite state machine running in the global call reference control block (see figure 4), in order to describe the restart procedure and the associated states defined in ETS 300 403-1 [1] subclause 5.5 and subclause 2.4, respectively.

Whenever a collision of restart procedures initiated by either side of the interface may occur, it shall be handled by a separate finite state machine approach.

NOTE: Due to the complexity of the representation, this approach is not presented.

In this subset of diagrams, reference is made to some flags in order to make the SDL representation more transparent. The flags have the following meaning:

- a) **REST RESP**: either by initiative of the management entity or because a **RESTART** message has been received, the global call reference control entity has sent primitives **RESTART REQUEST** to each protocol entity associated with an active call reference, and is waiting for a reply from them. The flag is set when they all have responded;
- b) **REST ACK**: by initiative of the management entity, the global call reference entity has sent a **RESTART** message to its peer entity (in the network side or in the user side), and is waiting for a **RESTART ACKNOWLEDGE**. The flag is set when this message is received;
- c) **T317 EXPIRED**: either by initiative of the management entity or because a **RESTART** message has been received, the global call reference control entity has sent primitives **RESTART REQUEST** to each protocol entity associated with an active call reference, and is waiting for a reply from them. The flag is set if they have not responded in due time, and timer T317 has expired.

---

## 8 Graphical SDL diagrams

This clause is separated into three subclauses:

- network side SDL diagrams (figure 5, sheets 1 to 85);
- user side SDL diagrams (figure 6, sheets 1 to 57);
- restart SDL diagrams (figure 7, sheets 1 to 7).

All references in the following diagrams are to ETS 300 403-1 [1].



# 8.1 Network side SDL diagrams

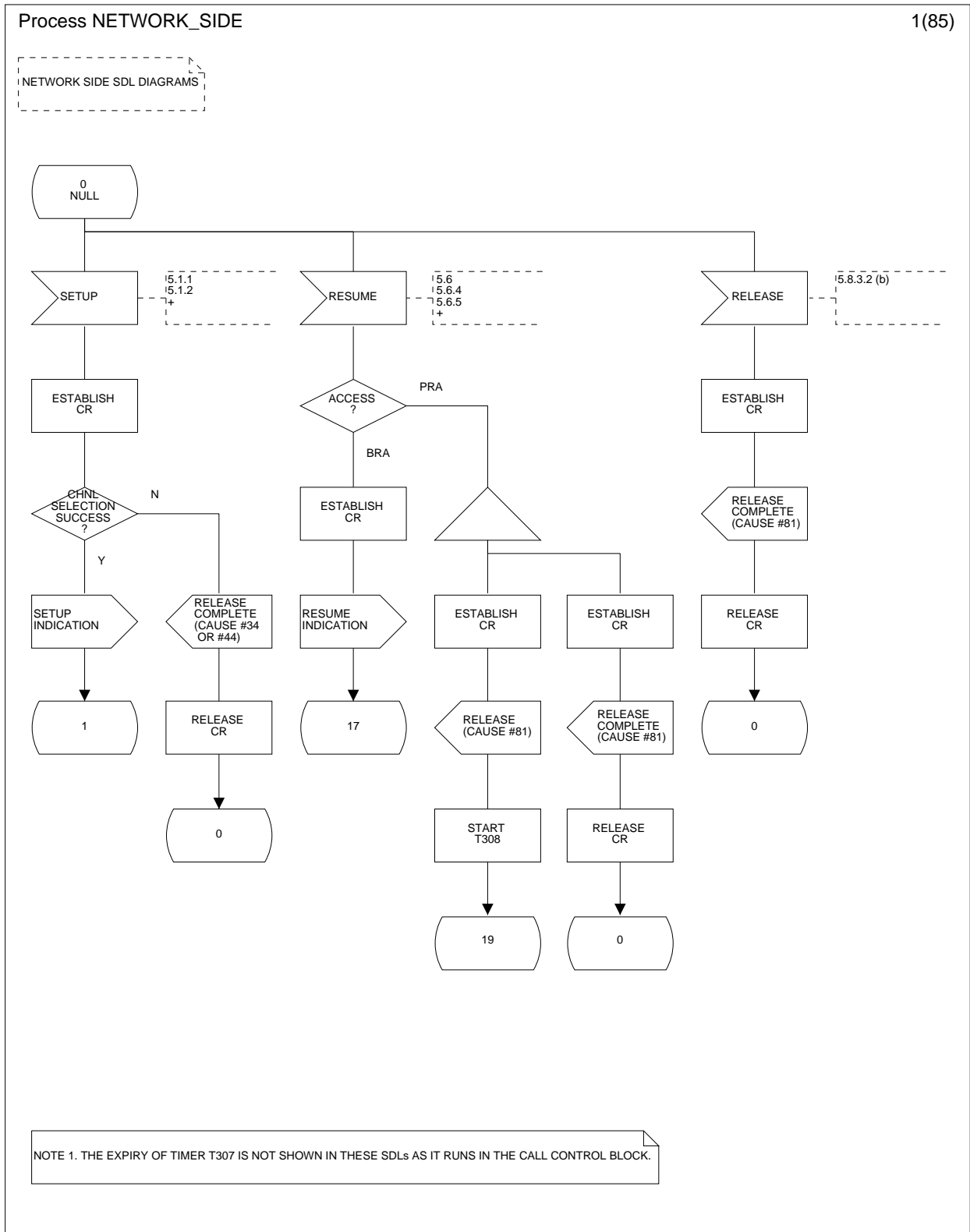

Figure 5 (sheet 1 of 85): Network side SDL diagram

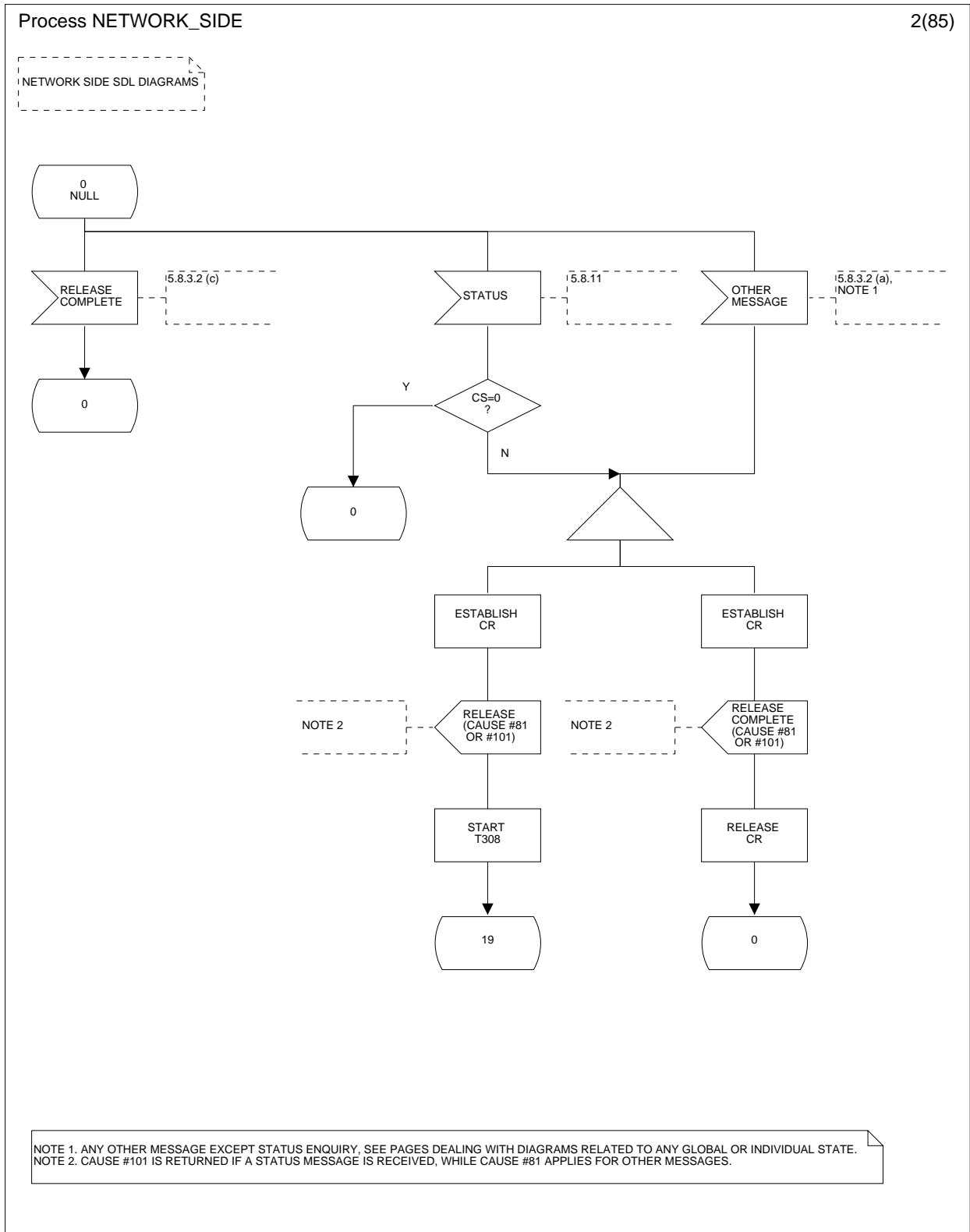

Figure 5 (sheet 2 of 85): Network side SDL diagram

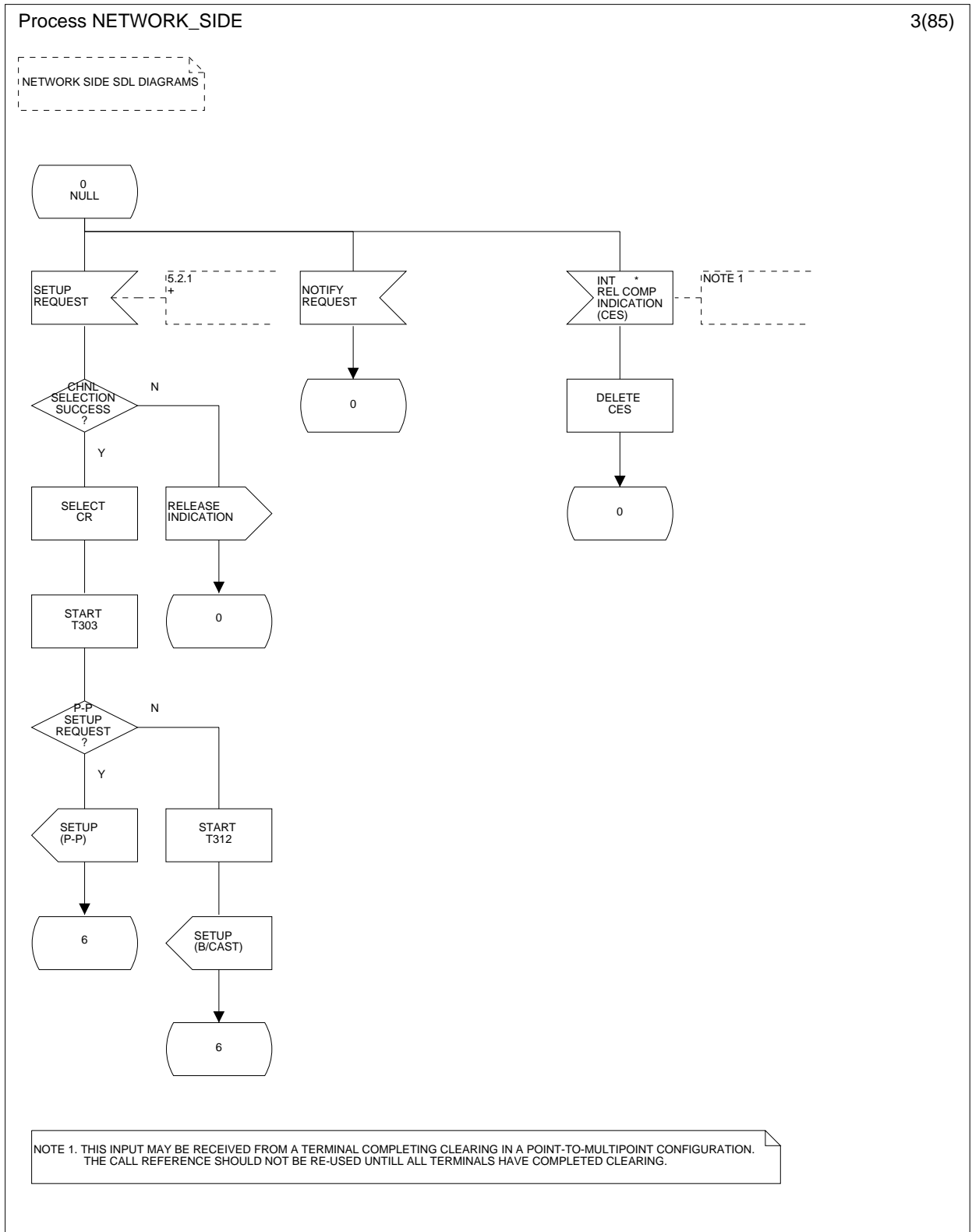

Figure 5 (sheet 3 of 85): Network side SDL diagram

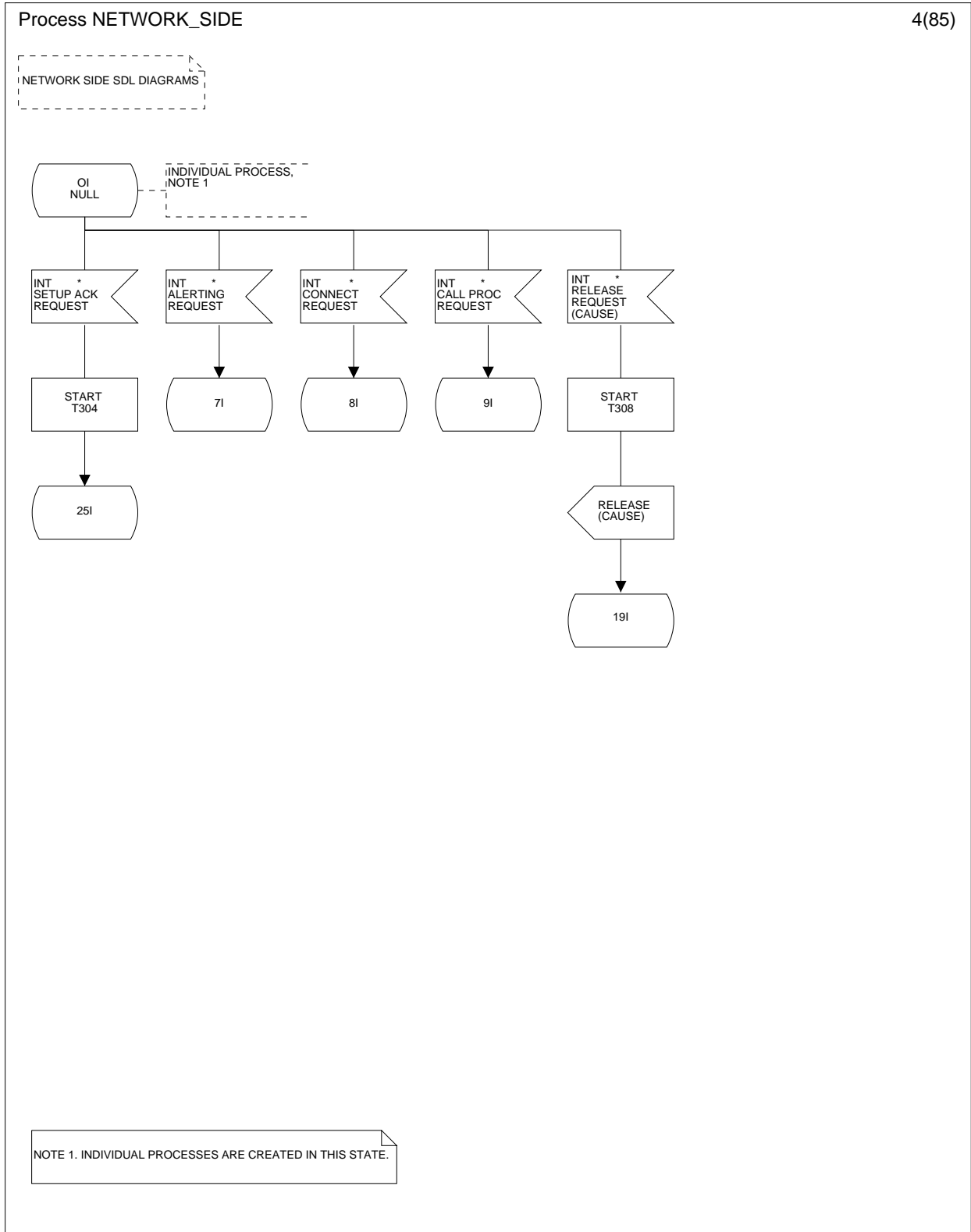

Figure 5 (sheet 4 of 85): Network side SDL diagram

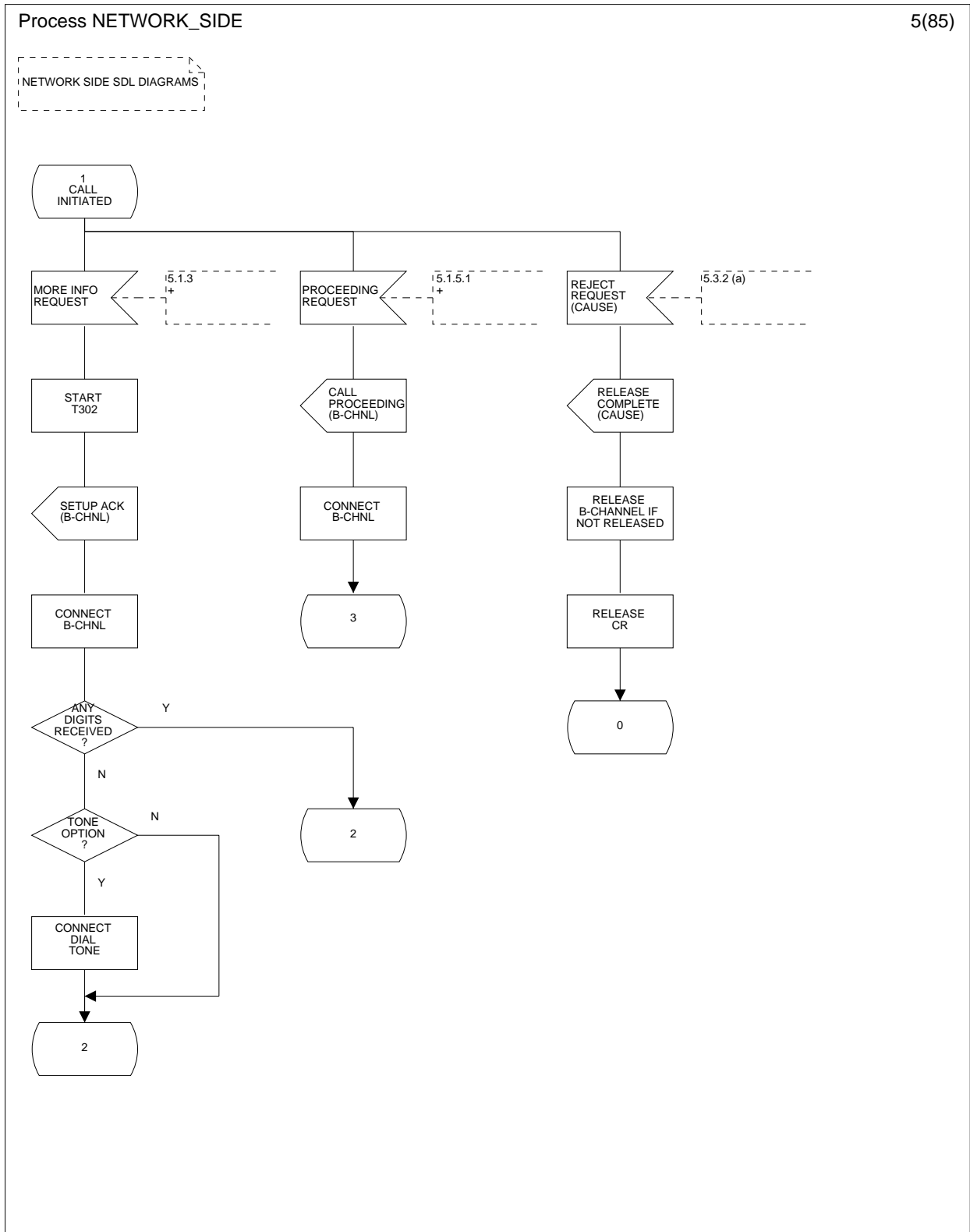

Figure 5 (sheet 5 of 85): Network side SDL diagram

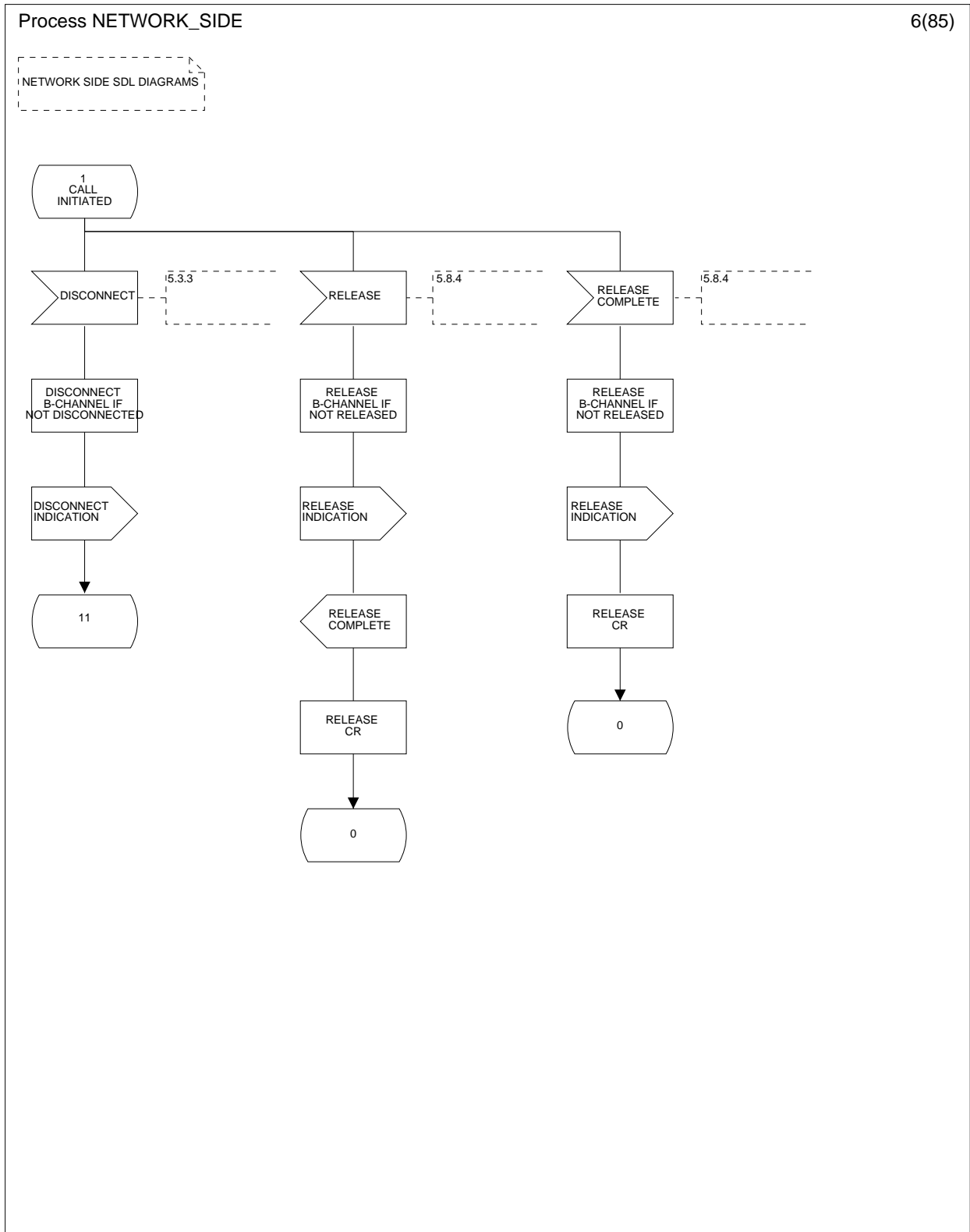

Figure 5 (sheet 6 of 85): Network side SDL diagram

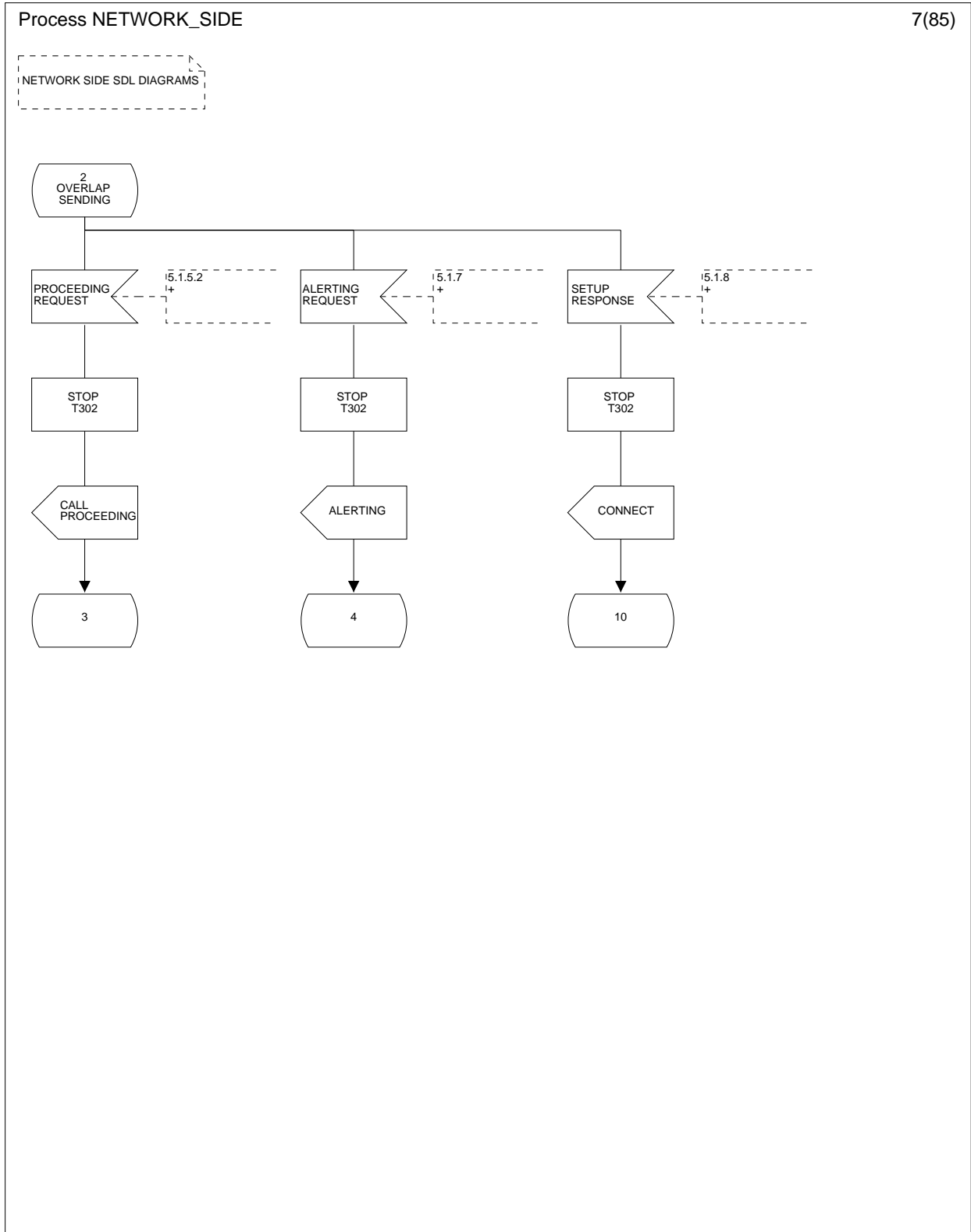

Figure 5 (sheet 7 of 85): Network side SDL diagram

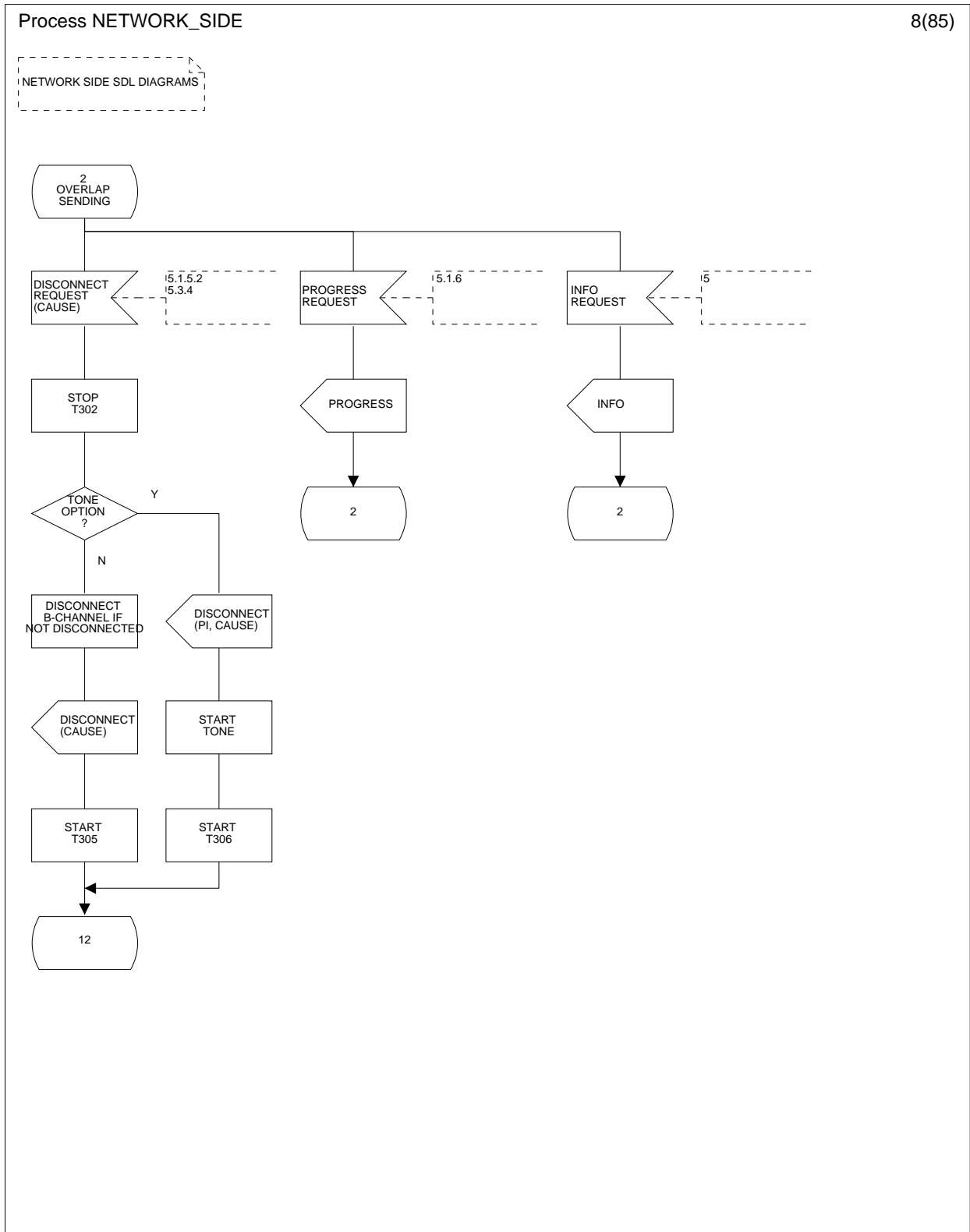

Figure 5 (sheet 8 of 85): Network side SDL diagram



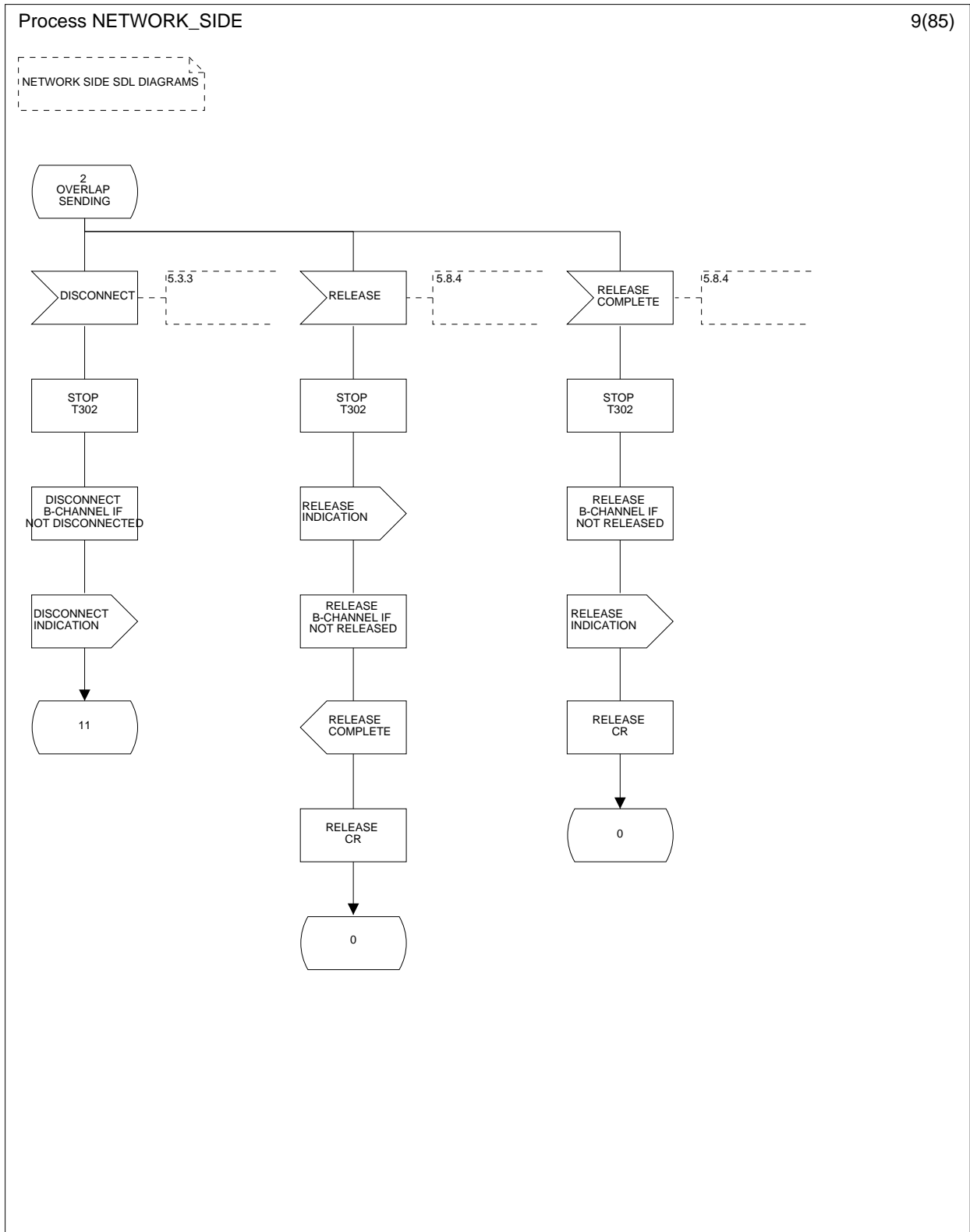

Figure 5 (sheet 9 of 85): Network side SDL diagram

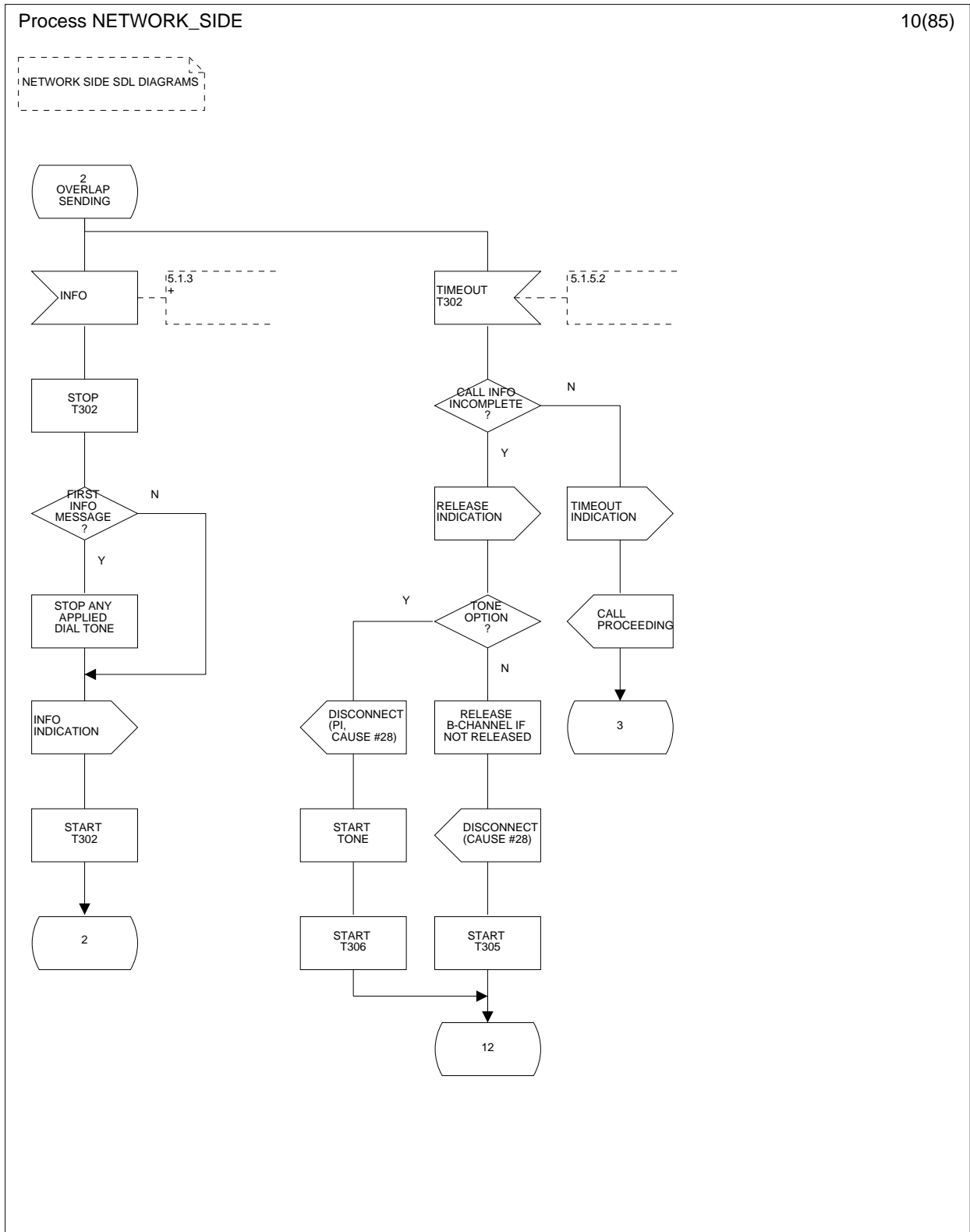

Figure 5 (sheet 10 of 85): Network side SDL diagram

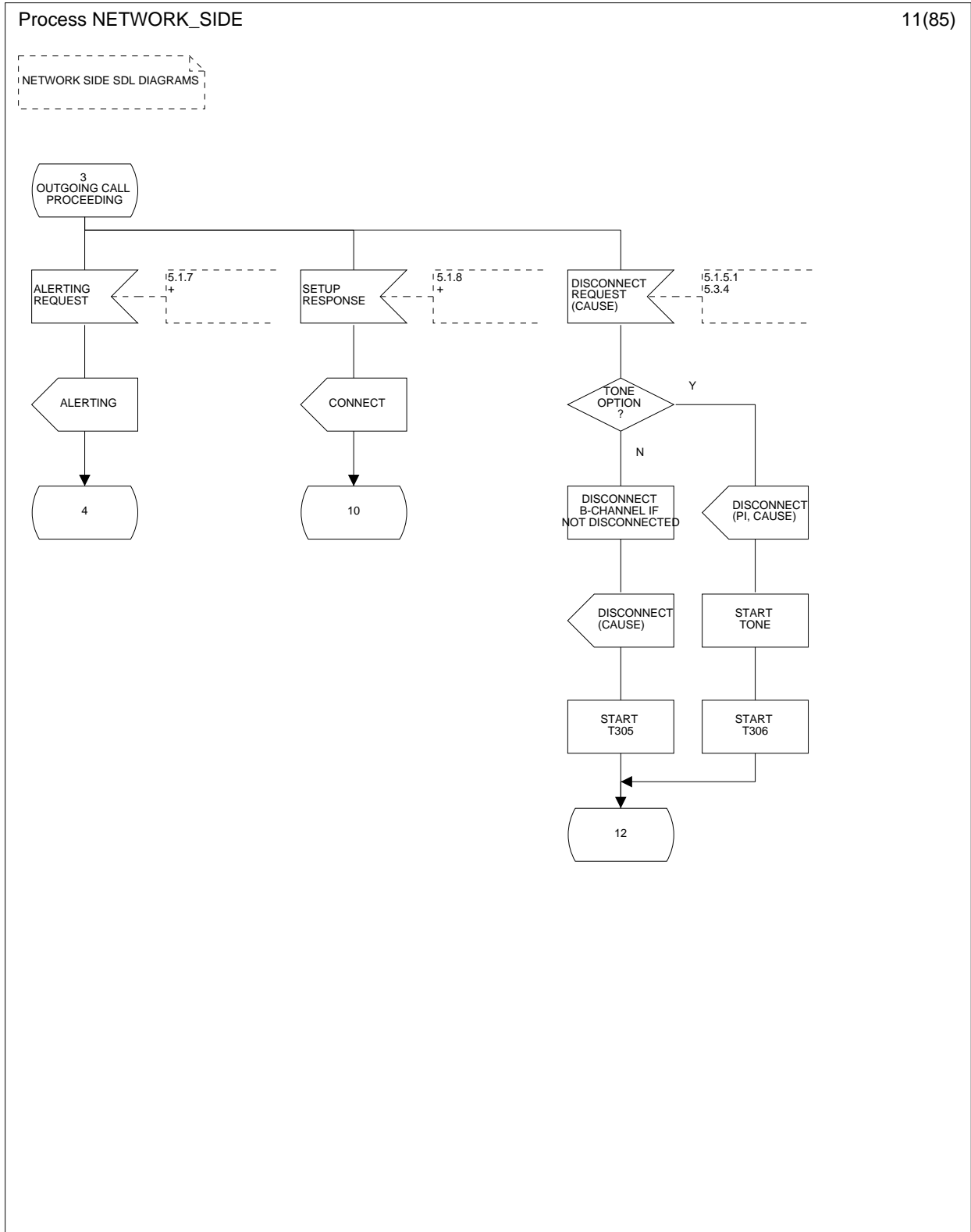

Figure 5 (sheet 11 of 85): Network side SDL diagram

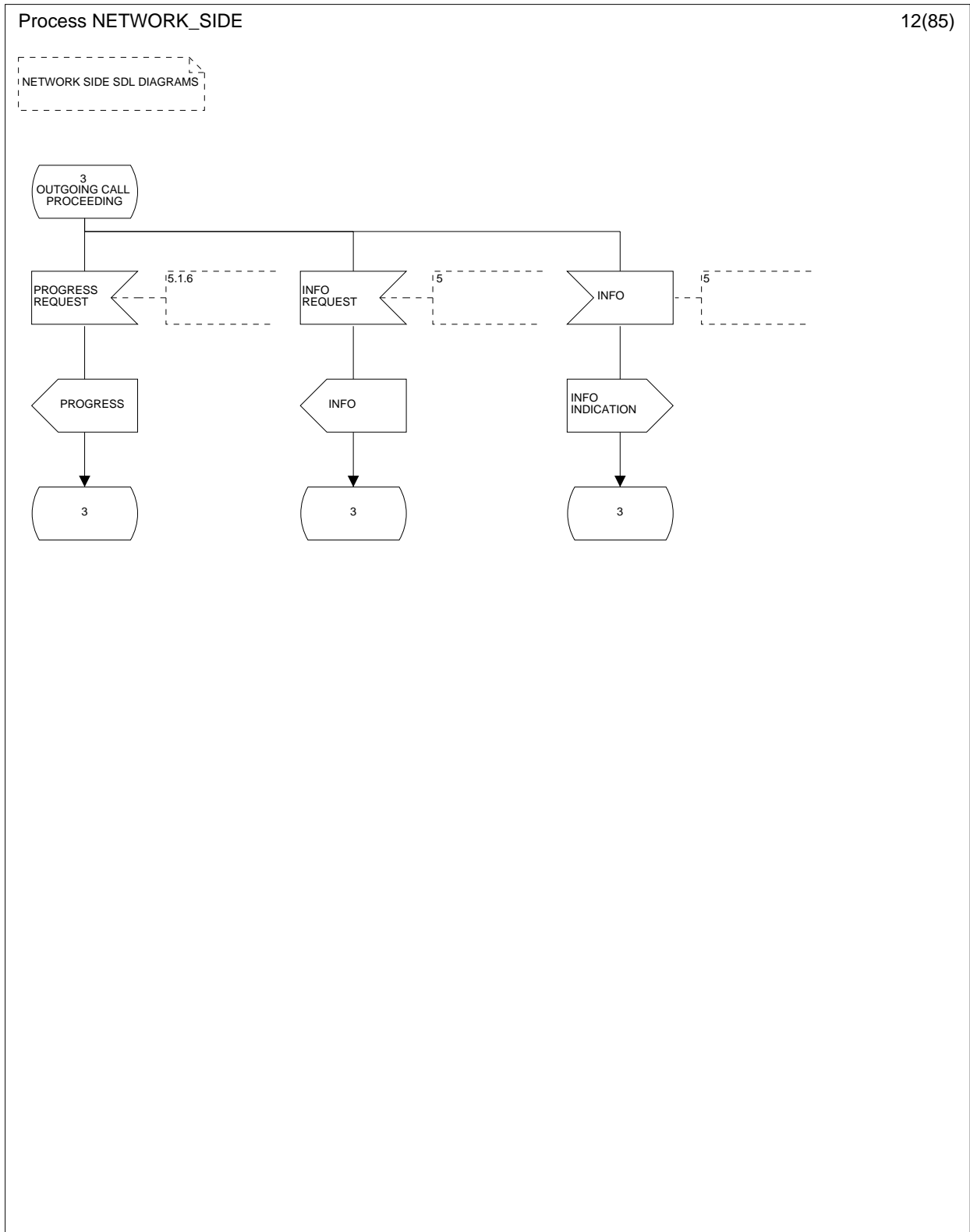

Figure 5 (sheet 12 of 85): Network side SDL diagram

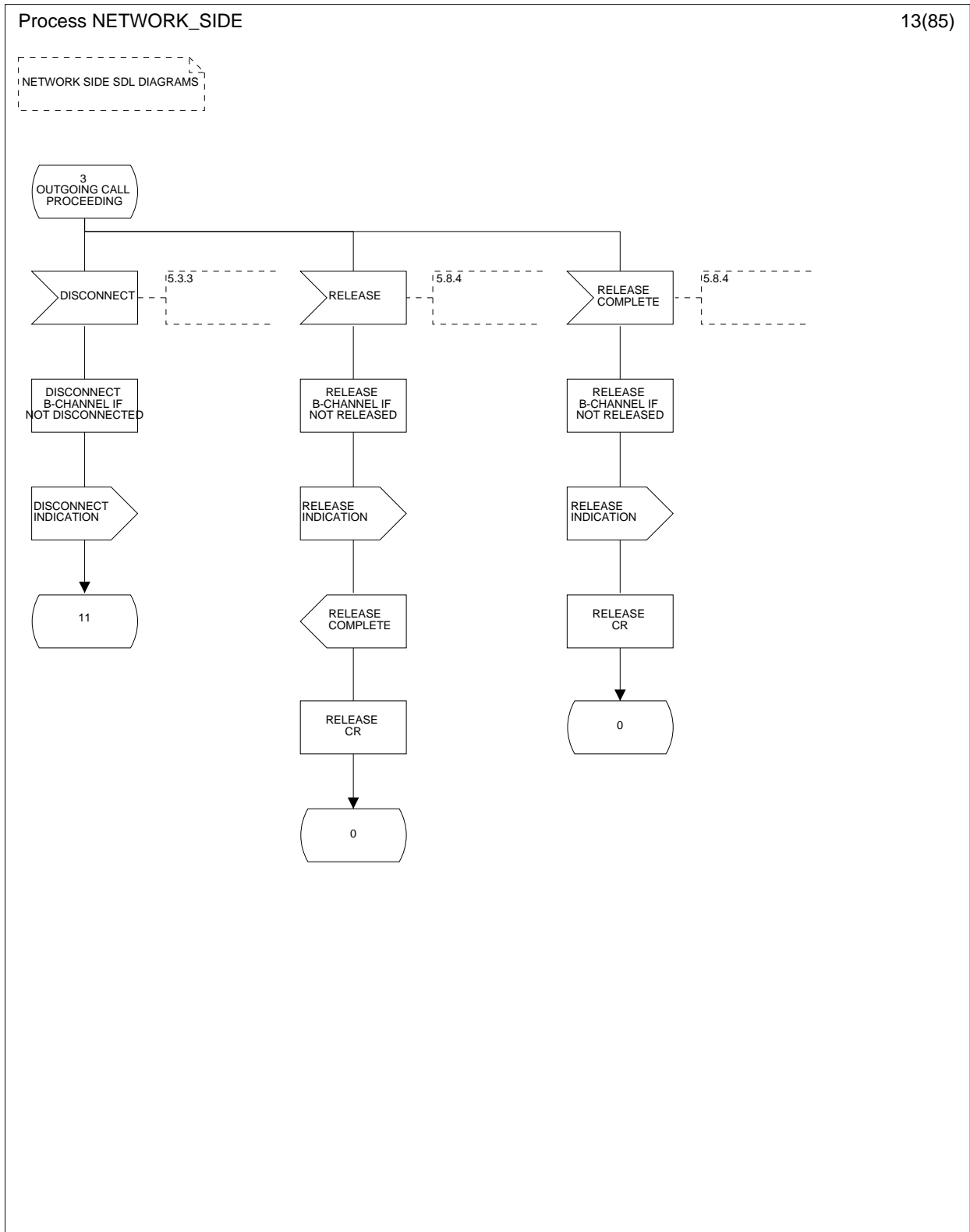

Figure 5 (sheet 13 of 85): Network side SDL diagram

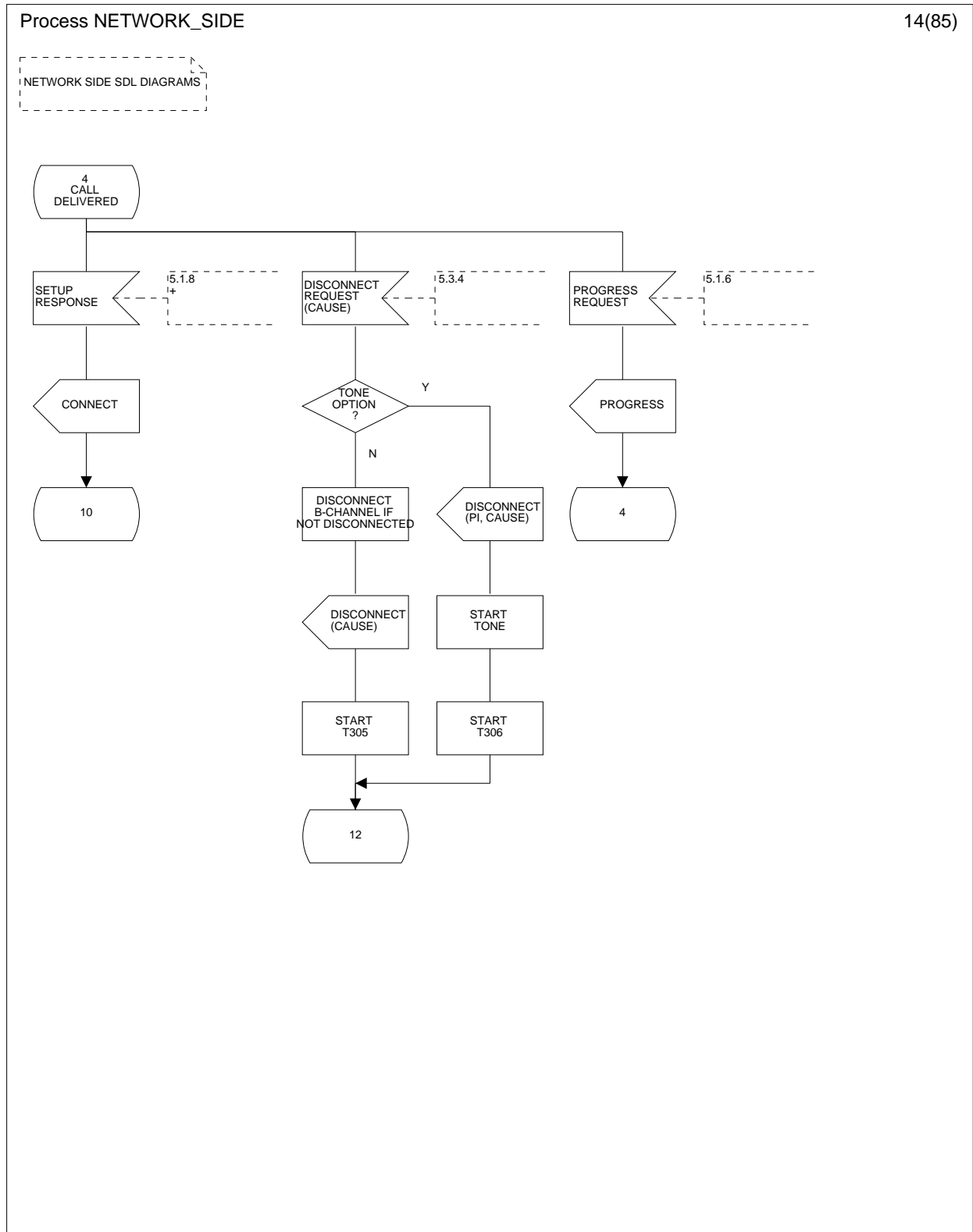

Figure 5 (sheet 14 of 85): Network side SDL diagram

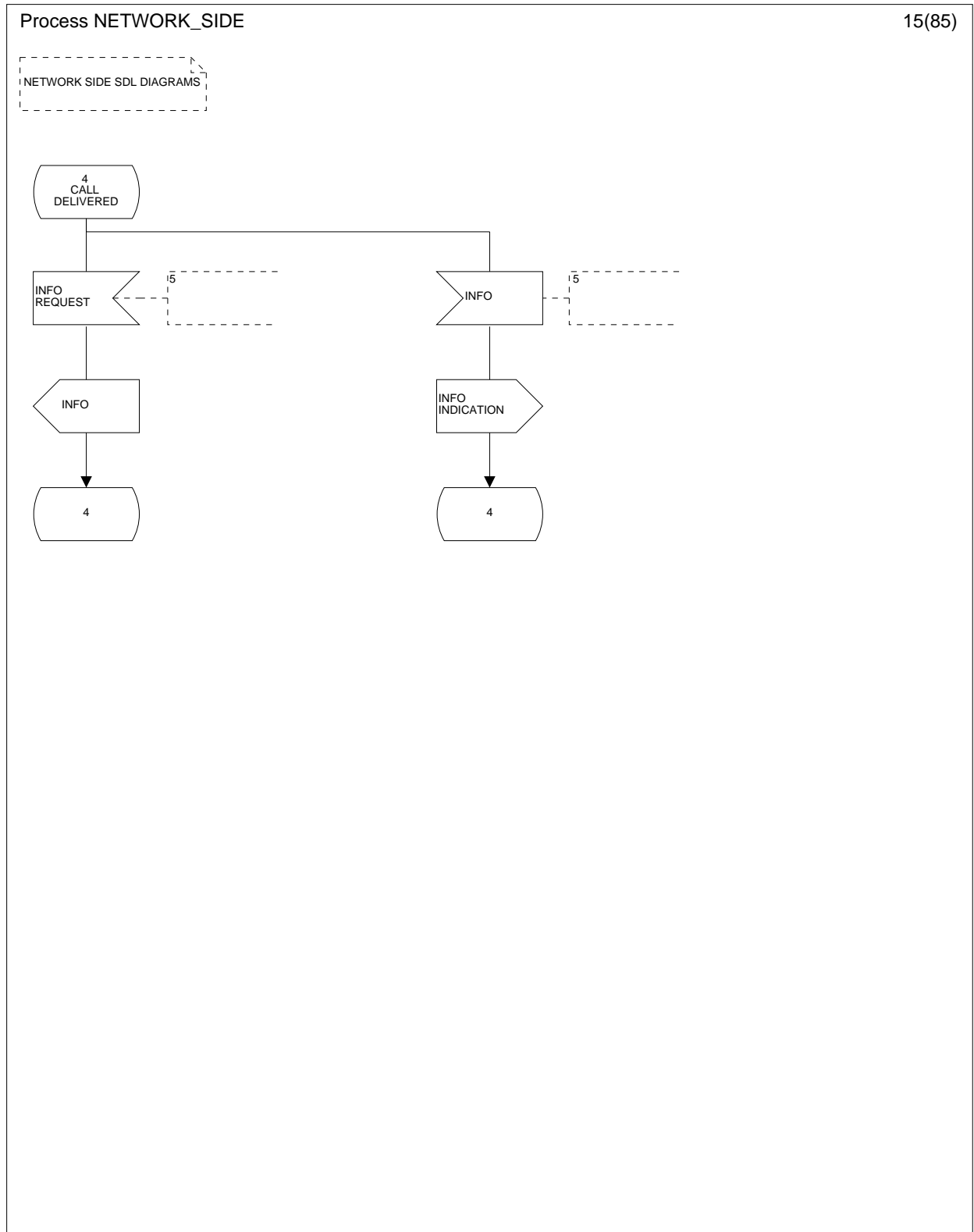

Figure 5 (sheet 15 of 85): Network side SDL diagram

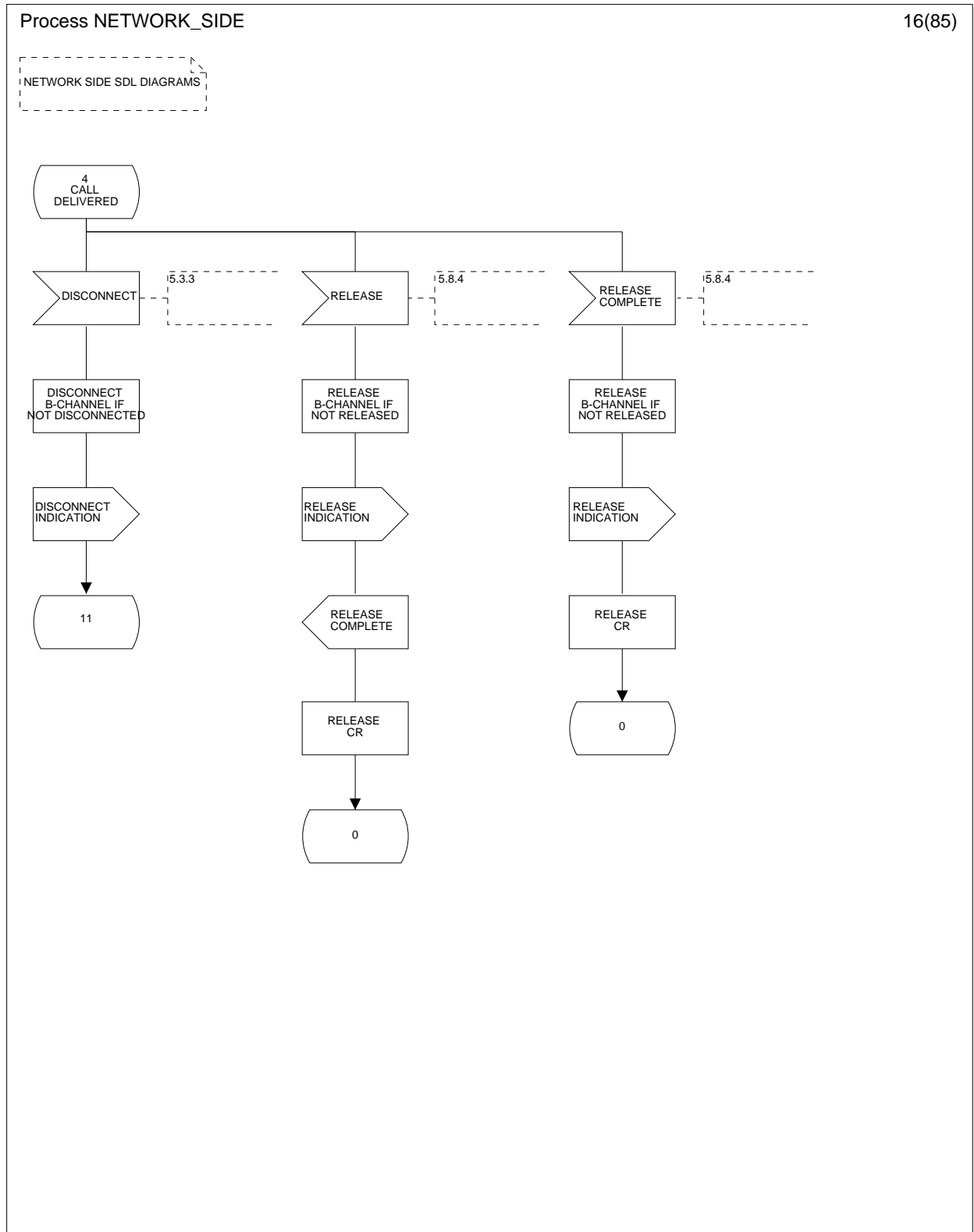

Figure 5 (sheet 16 of 85): Network side SDL diagram



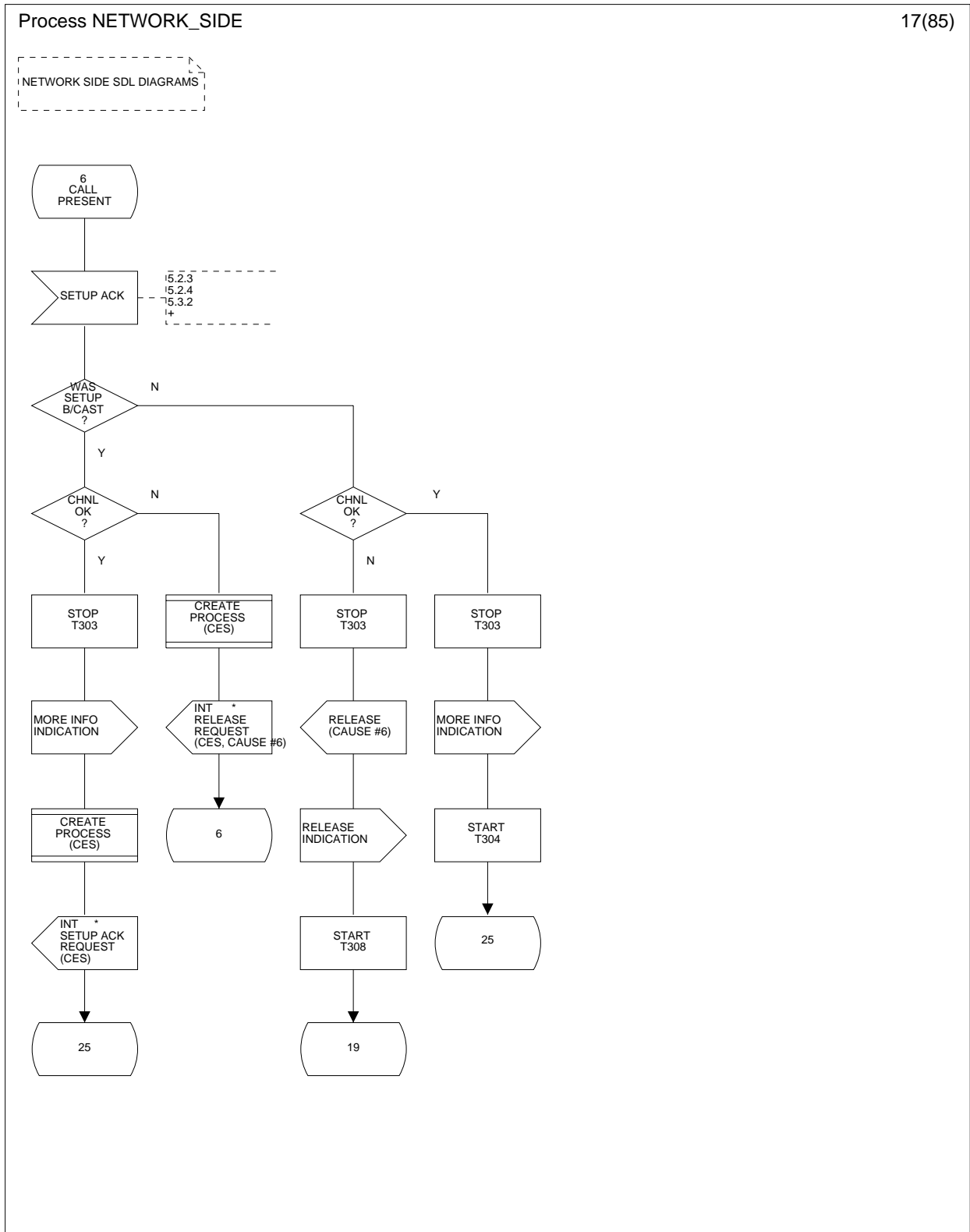

Figure 5 (sheet 17 of 85): Network side SDL diagram

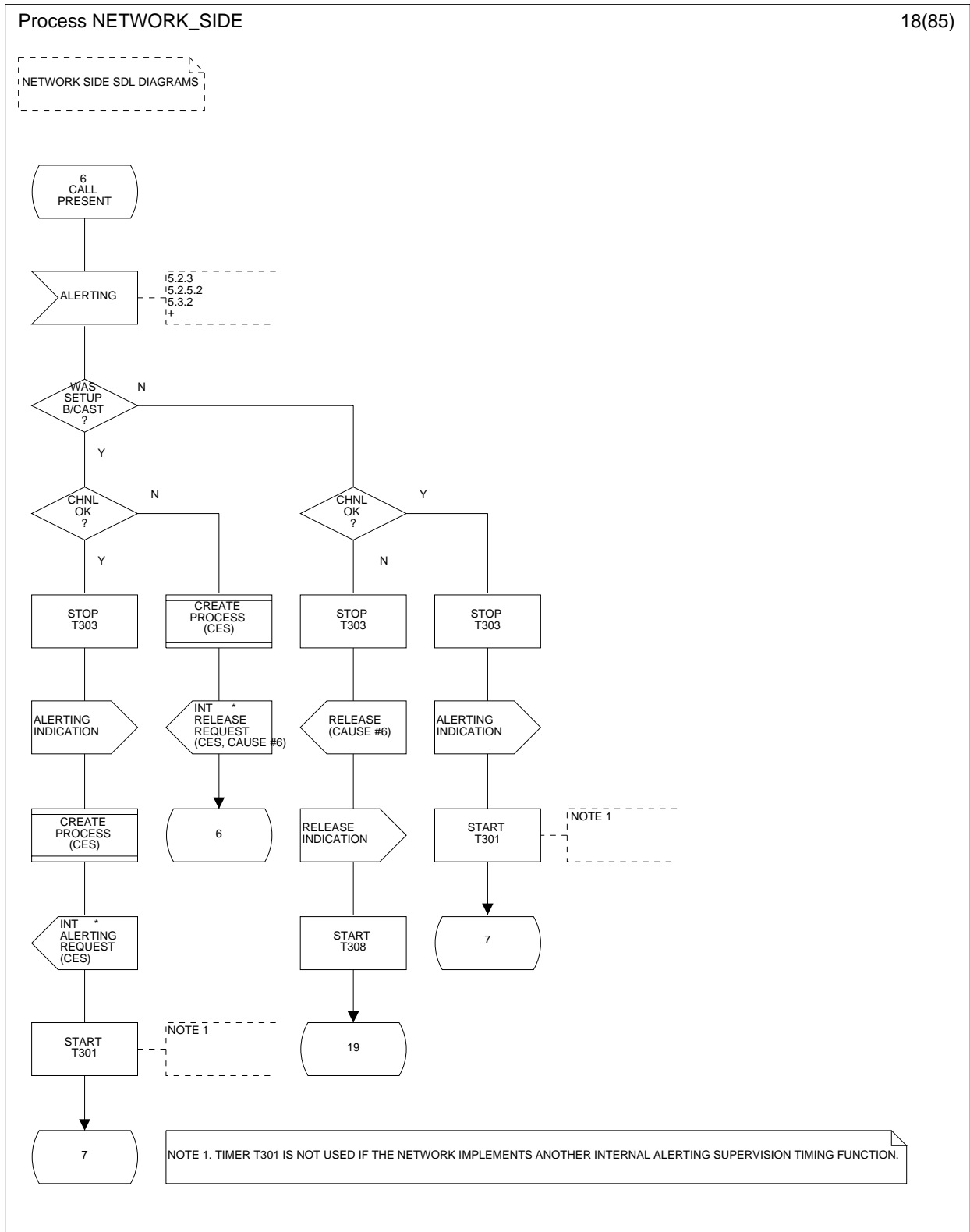

Figure 5 (sheet 18 of 85): Network side SDL diagram

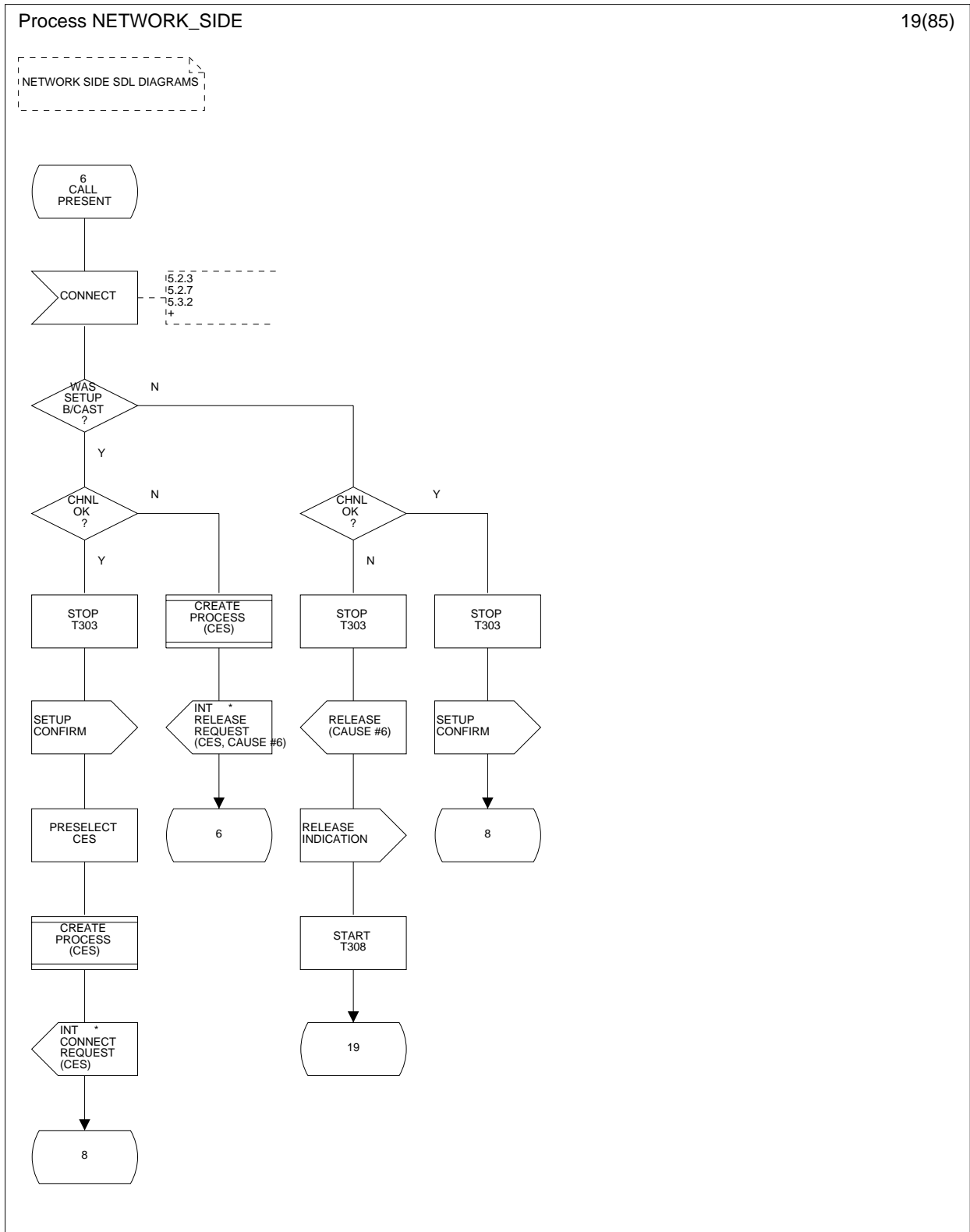

Figure 5 (sheet 19 of 85): Network side SDL diagram

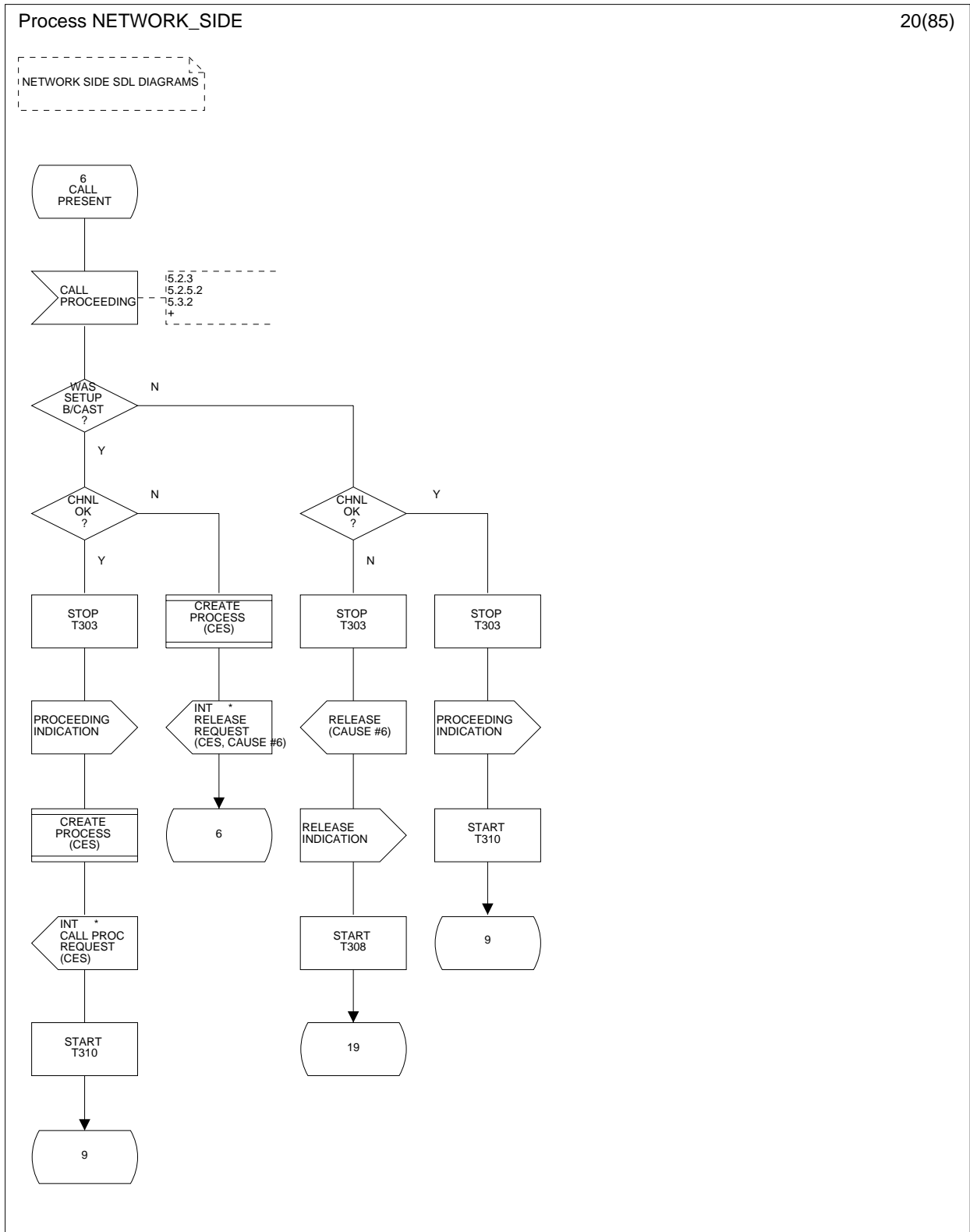

Figure 5 (sheet 20 of 85): Network side SDL diagram

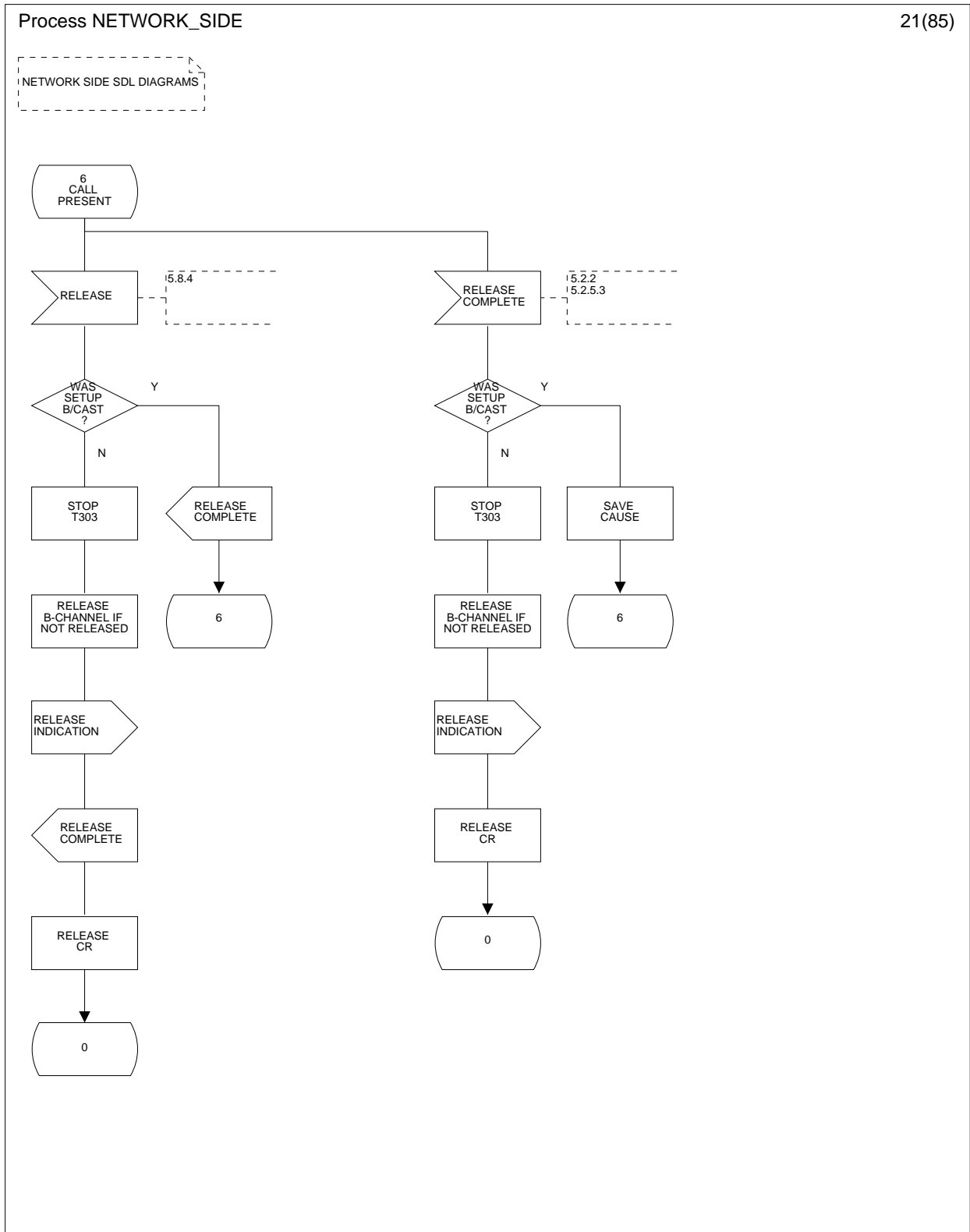

Figure 5 (sheet 21 of 85): Network side SDL diagram

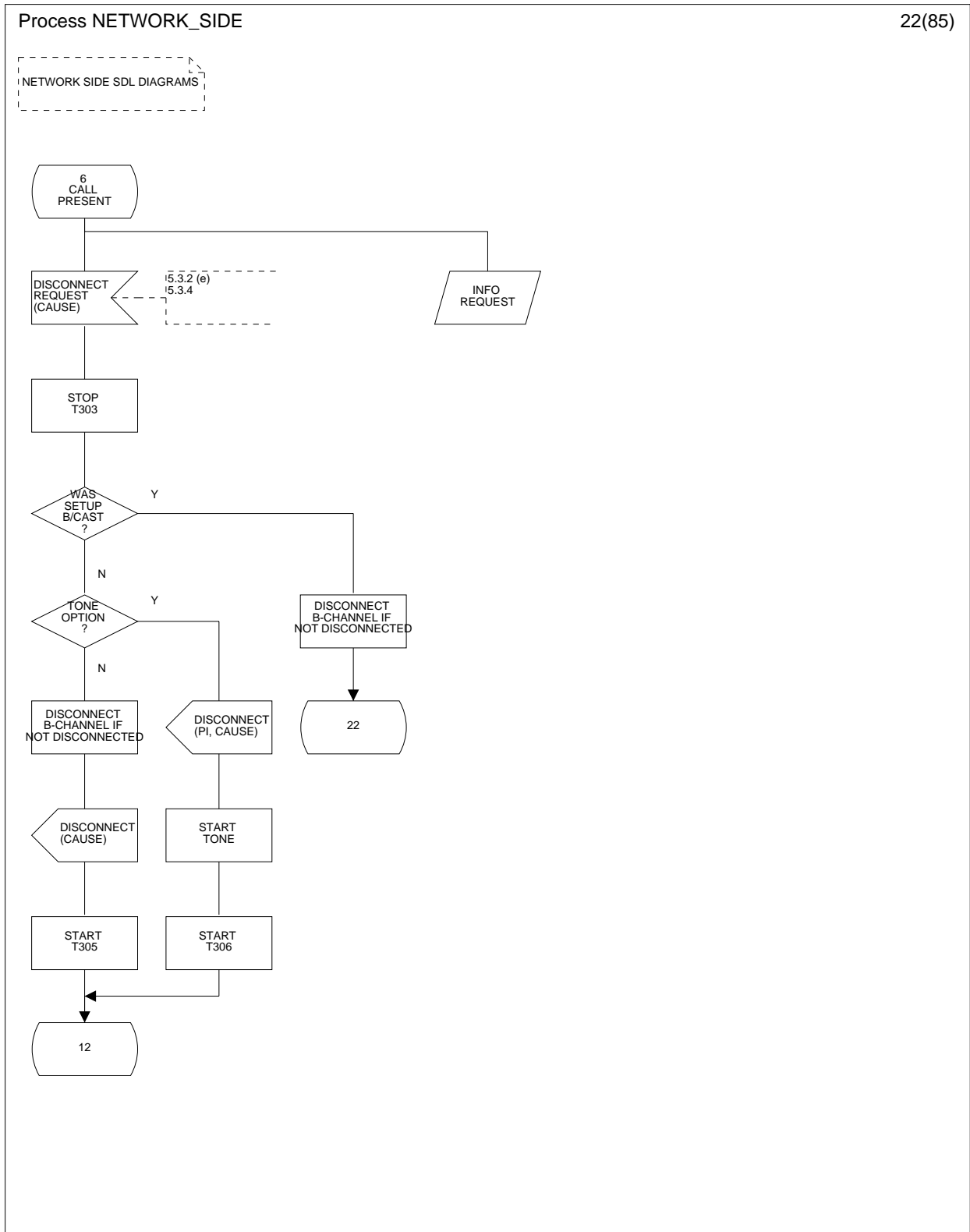

Figure 5 (sheet 22 of 85): Network side SDL diagram

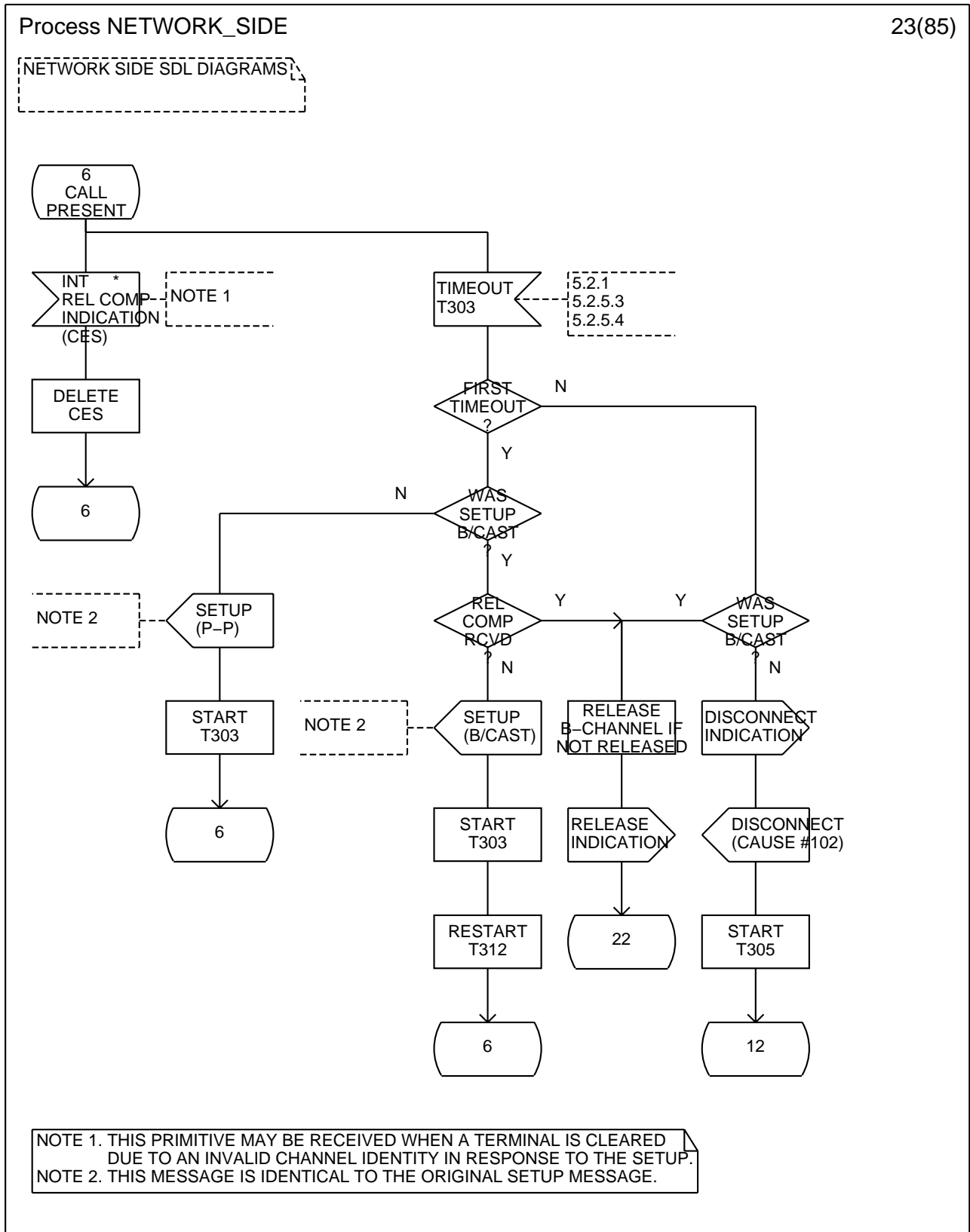

Figure 5 (sheet 23 of 85): Network side SDL diagram

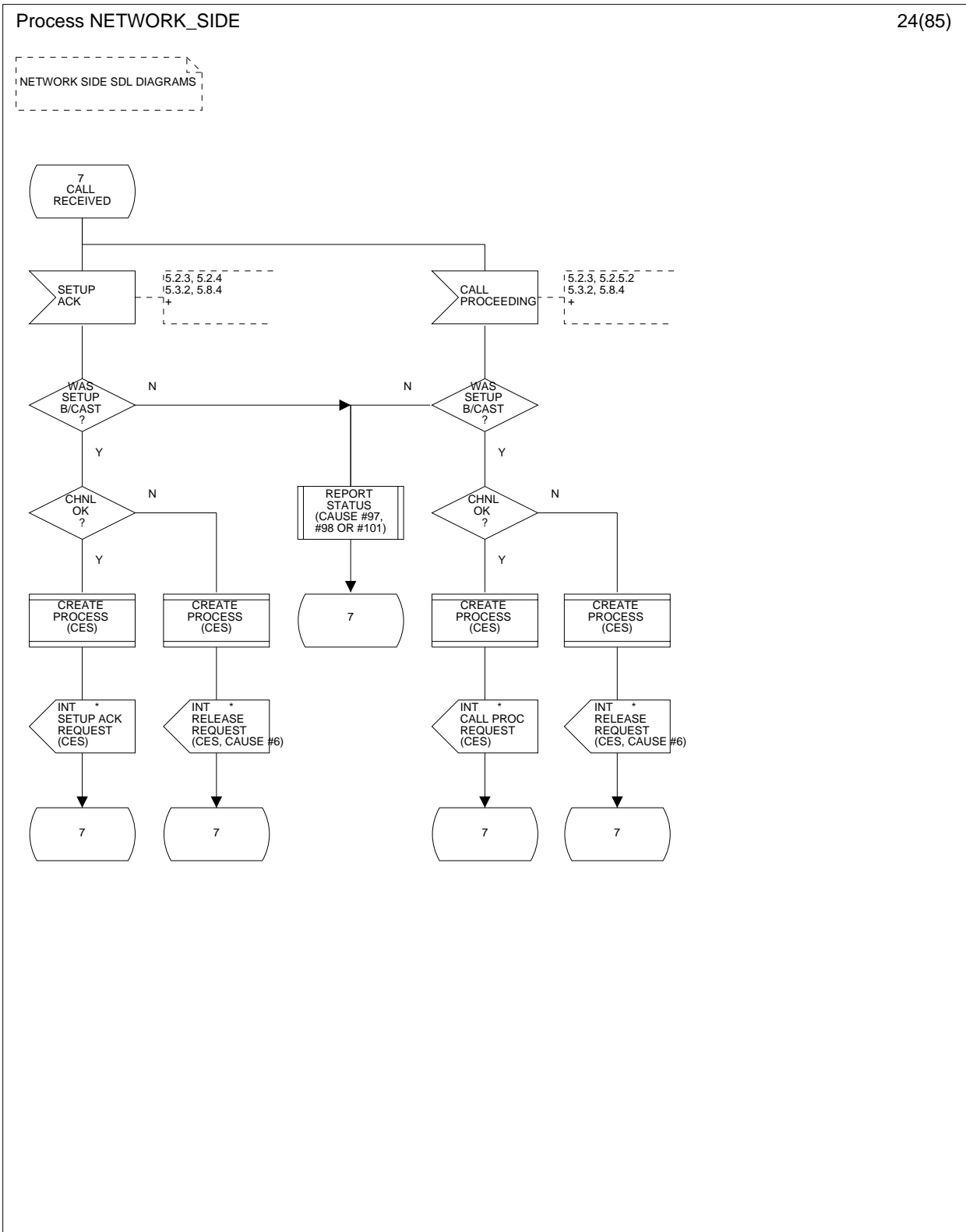

Figure 5 (sheet 24 of 85): Network side SDL diagram



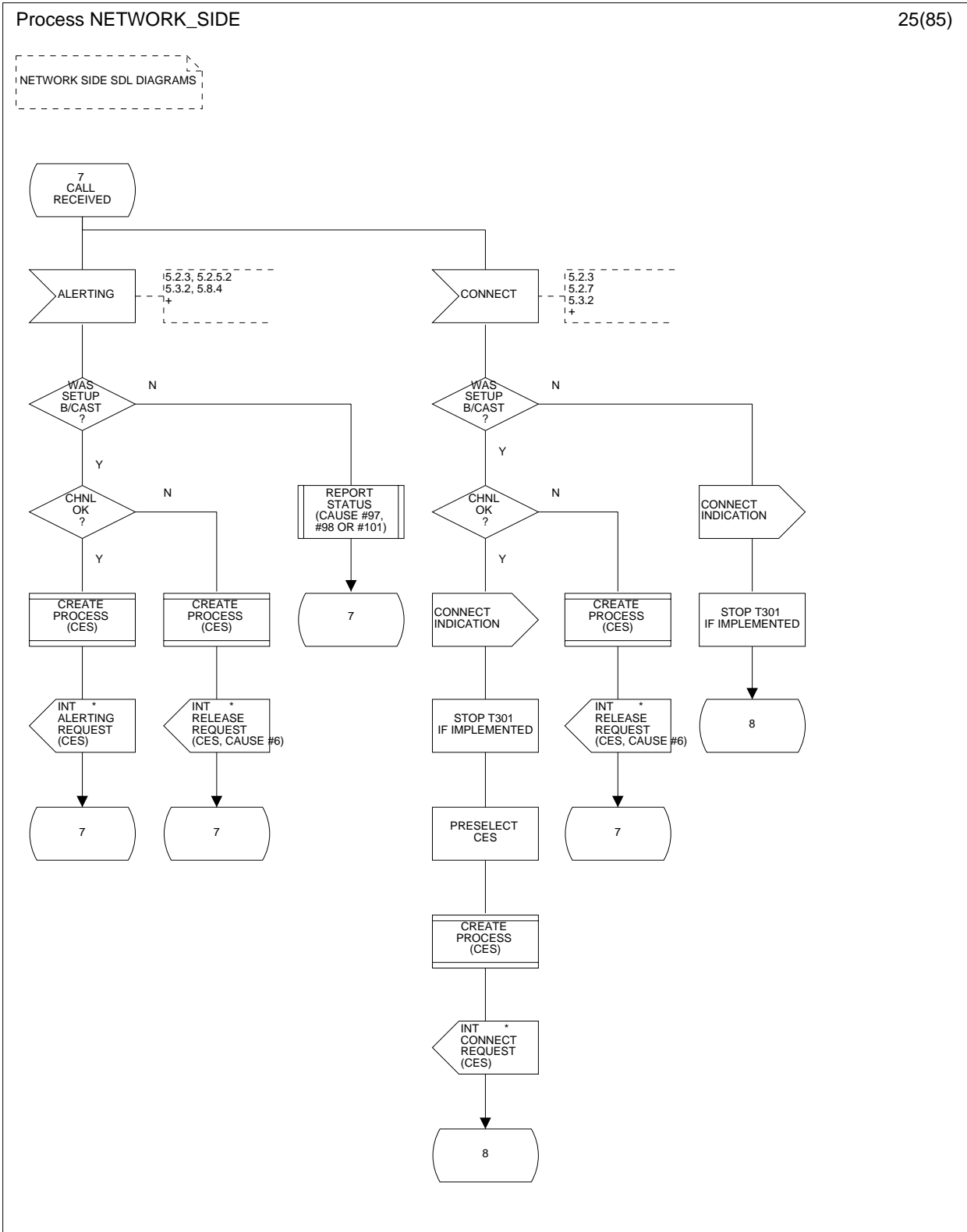

Figure 5 (sheet 25 of 85): Network side SDL diagram

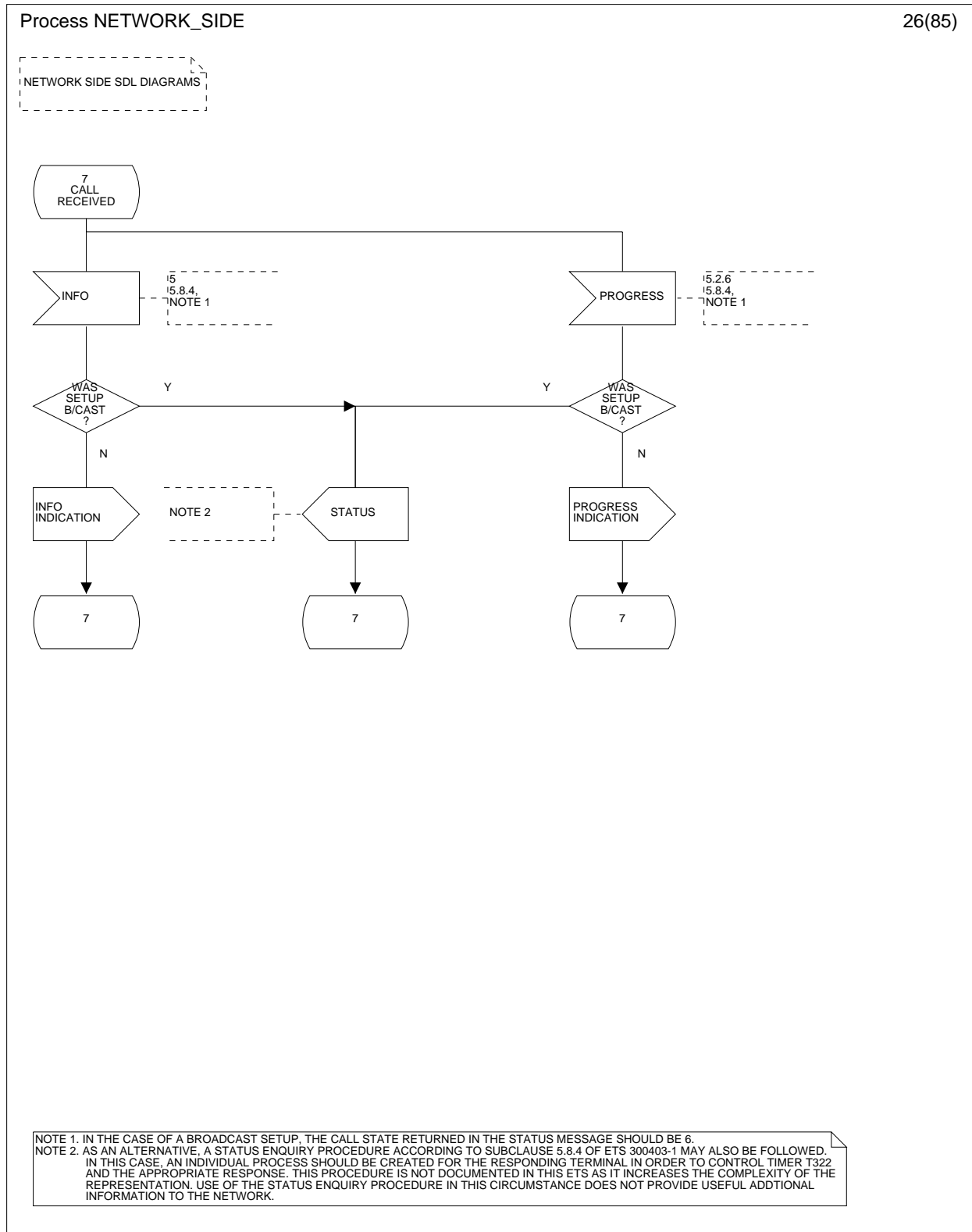

Figure 5 (sheet 26 of 85): Network side SDL diagram

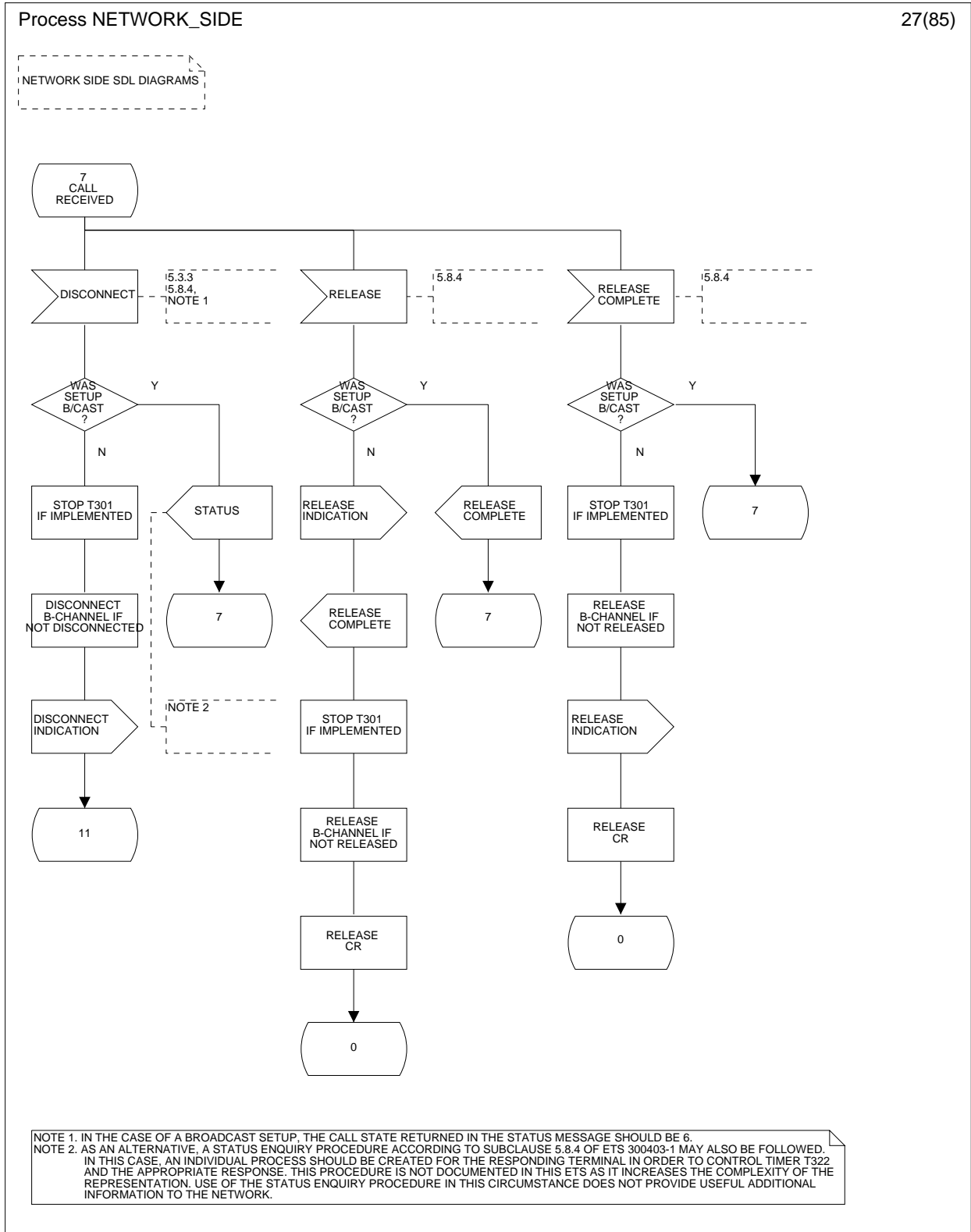

Figure 5 (sheet 27 of 85): Network side SDL diagram

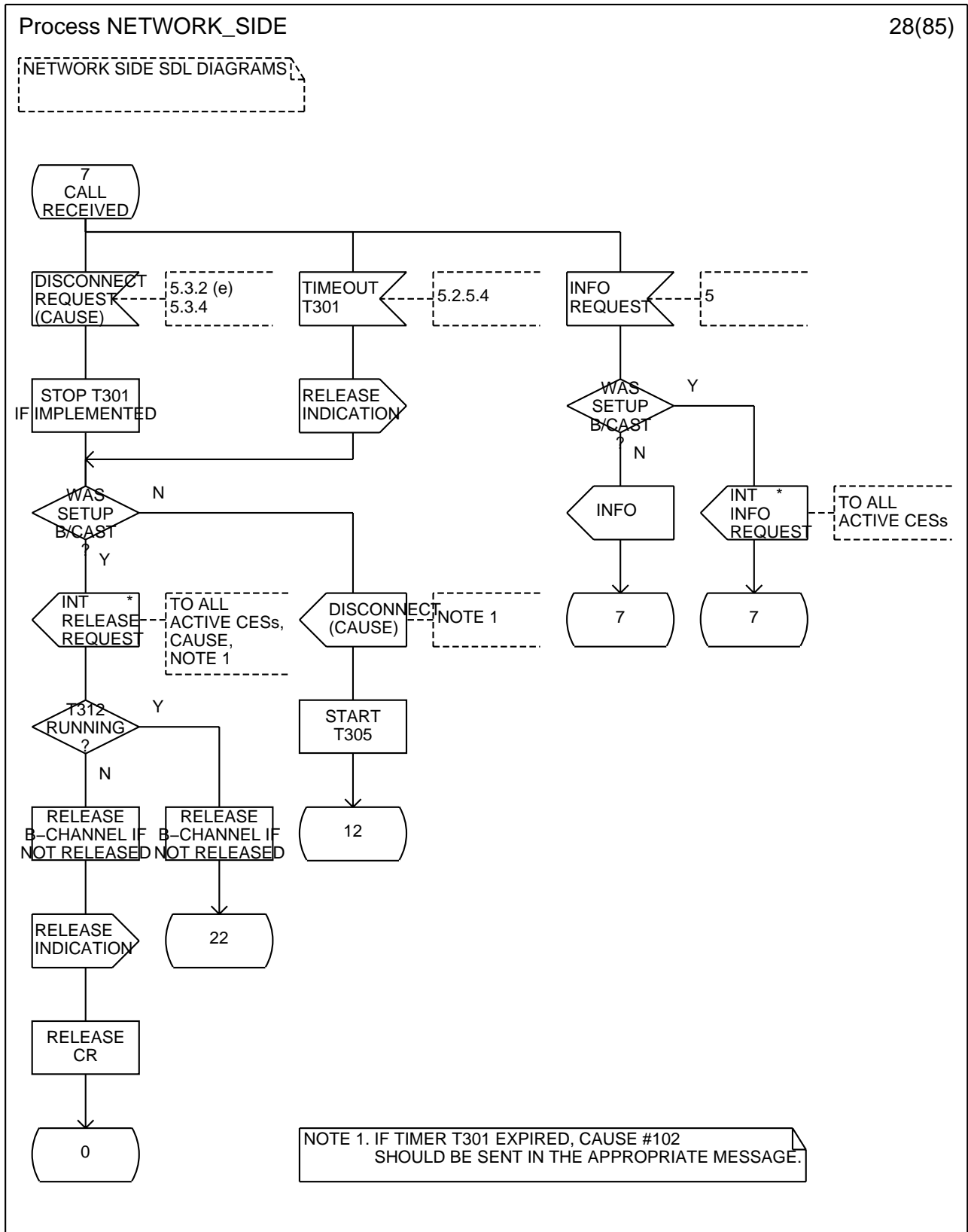

Figure 5 (sheet 28 of 85): Network side SDL diagram

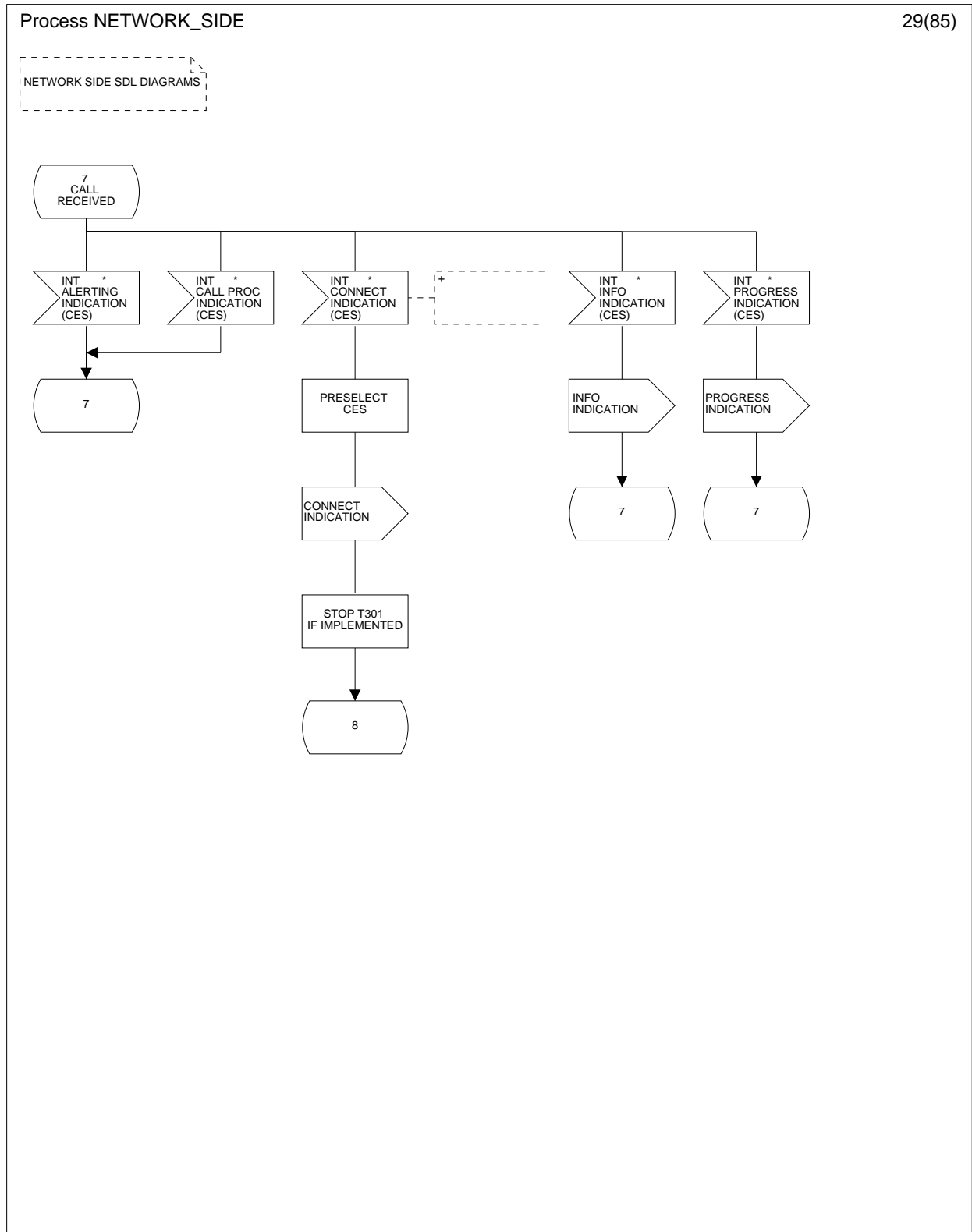

Figure 5 (sheet 29 of 85): Network side SDL diagram

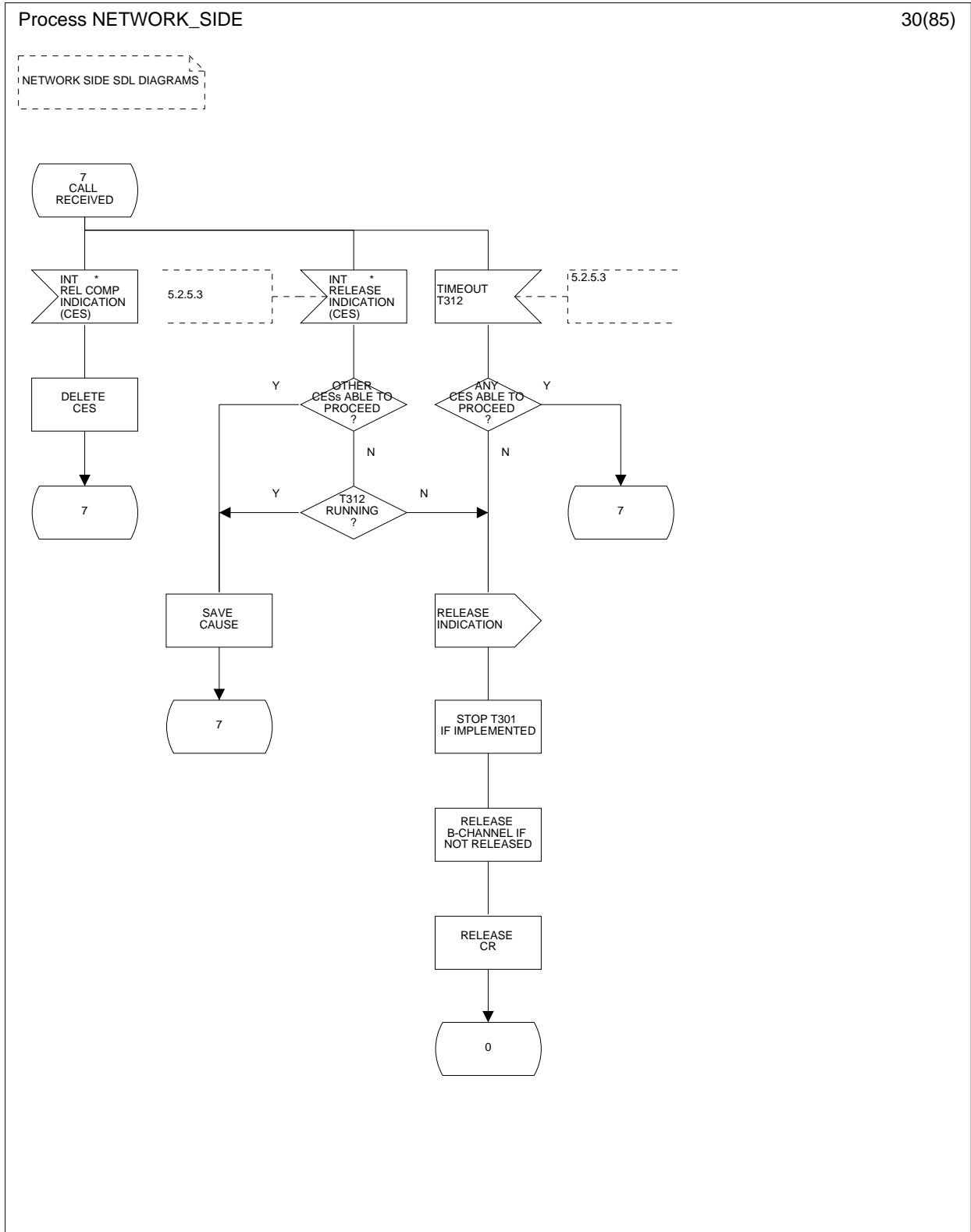

Figure 5 (sheet 30 of 85): Network side SDL diagram

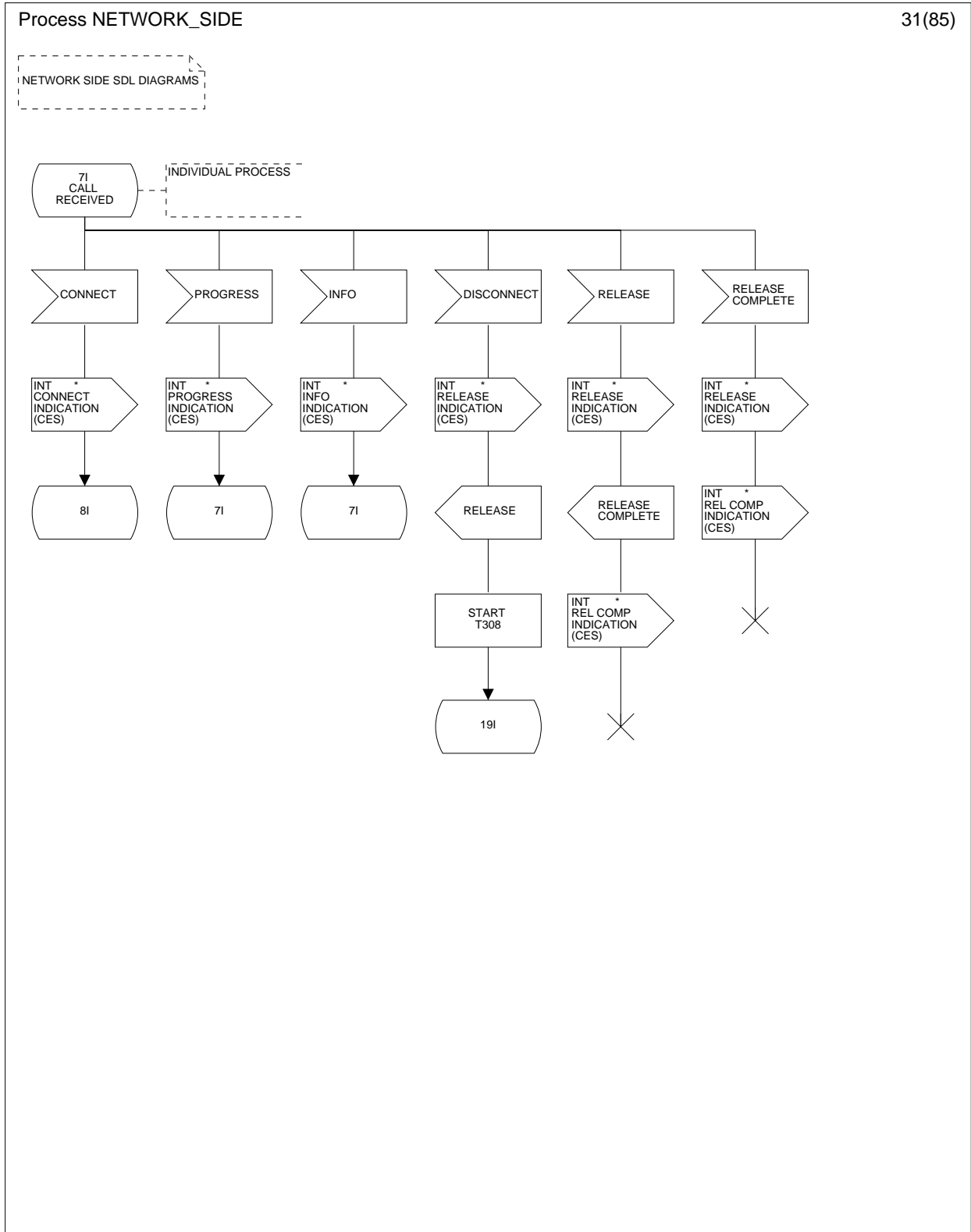

Figure 5 (sheet 31 of 85): Network side SDL diagram

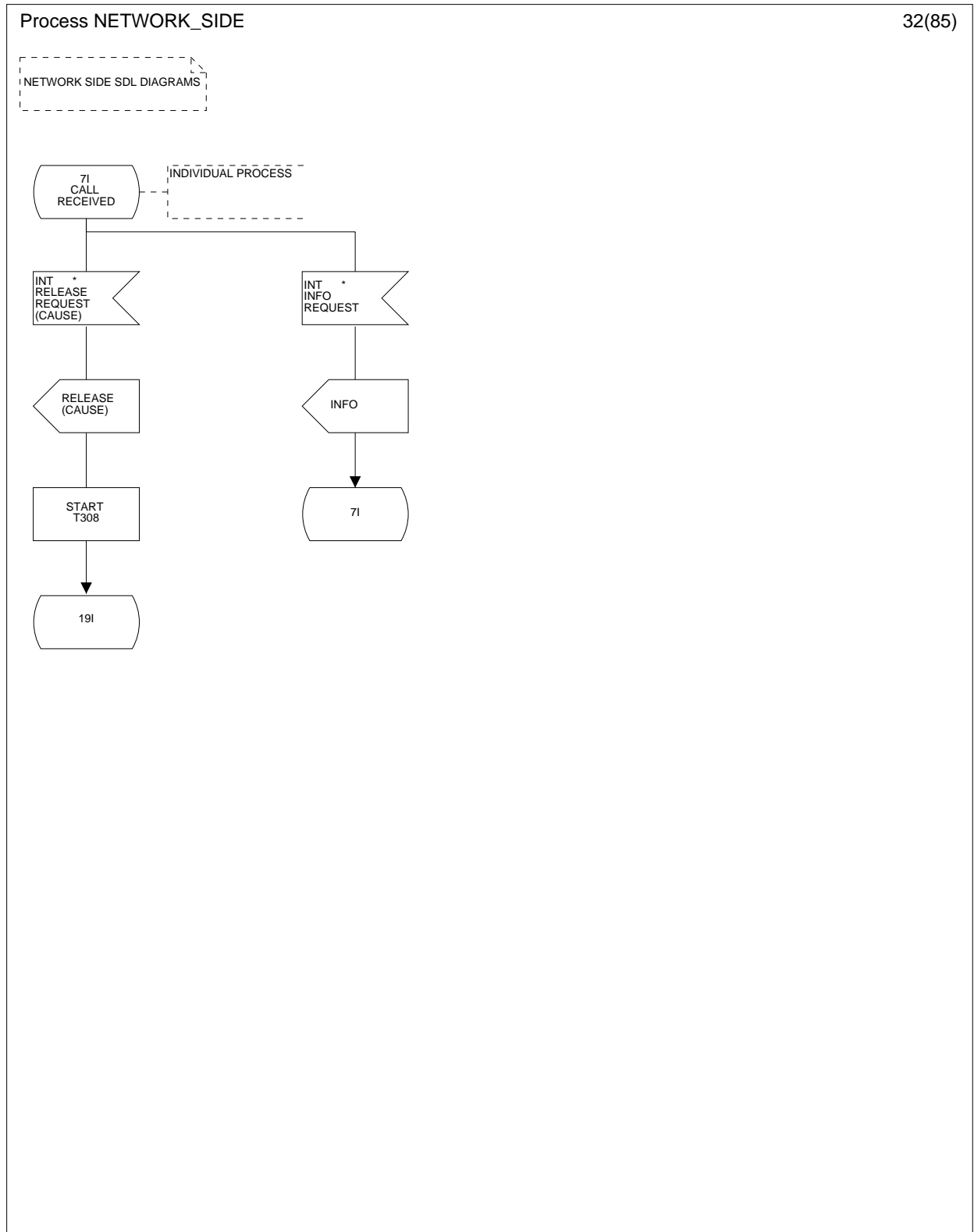

Figure 5 (sheet 32 of 85): Network side SDL diagram



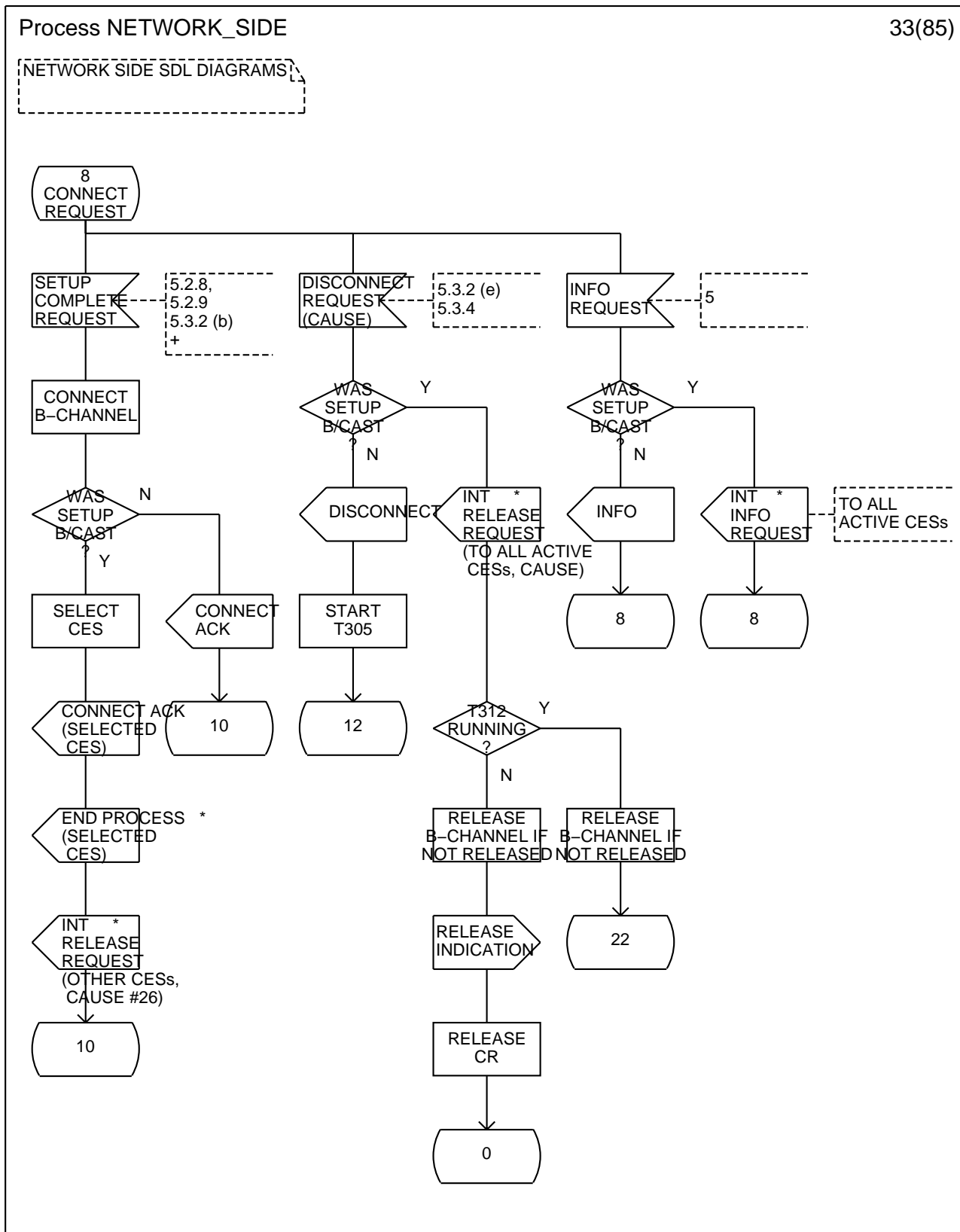

Figure 5 (sheet 33 of 85): Network side SDL diagram

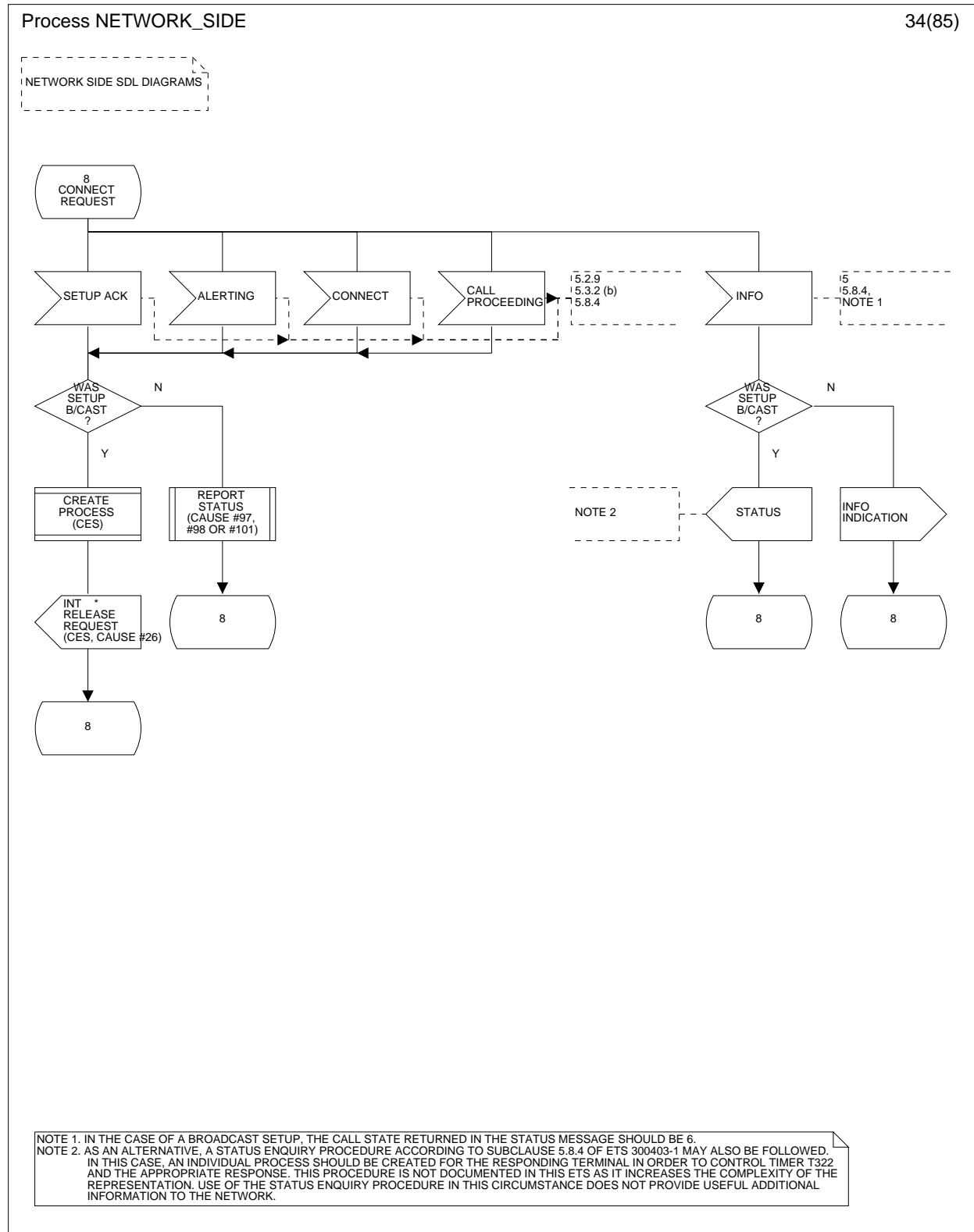
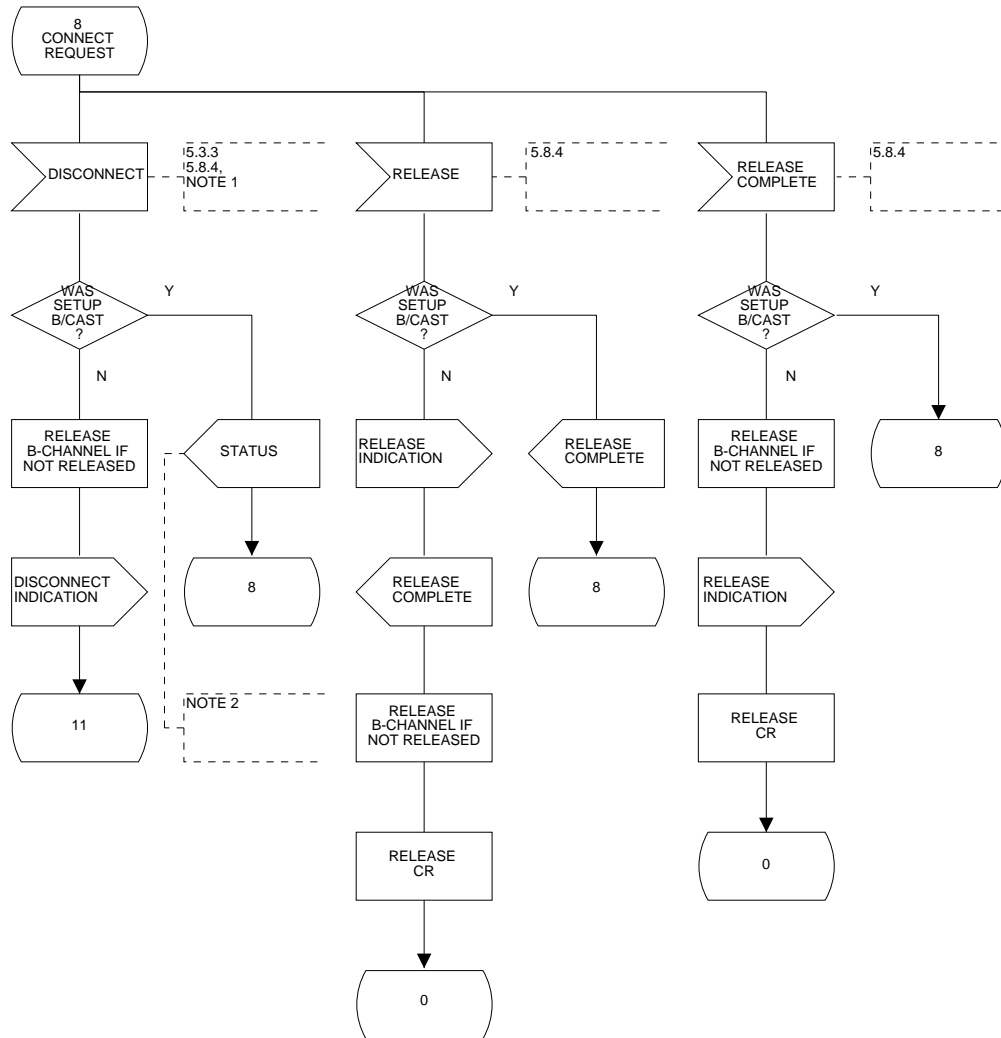

Figure 5 (sheet 34 of 85): Network side SDL diagram

Process NETWORK\_SIDE

35(85)

NETWORK SIDE SDL DIAGRAMS



NOTE 1. IN THE CASE OF A BROADCAST SETUP, THE CALL STATE RETURNED IN THE STATUS MESSAGE SHOULD BE 6.  
 NOTE 2. AS AN ALTERNATIVE, A STATUS ENQUIRY PROCEDURE ACCORDING TO SUBCLAUSE 5.8.4 OF ETS 300403-1 MAY ALSO BE FOLLOWED. IN THIS CASE, AN INDIVIDUAL PROCESS SHOULD BE CREATED FOR THE RESPONDING TERMINAL IN ORDER TO CONTROL TIMER T322 AND THE APPROPRIATE RESPONSE. THIS PROCEDURE IS NOT DOCUMENTED IN THIS ETS AS IT INCREASES THE COMPLEXITY OF THE REPRESENTATION. USE OF THE STATUS ENQUIRY PROCEDURE IN THIS CIRCUMSTANCE DOES NOT PROVIDE USEFUL ADDITIONAL INFORMATION TO THE NETWORK.

Figure 5 (sheet 35 of 85): Network side SDL diagram

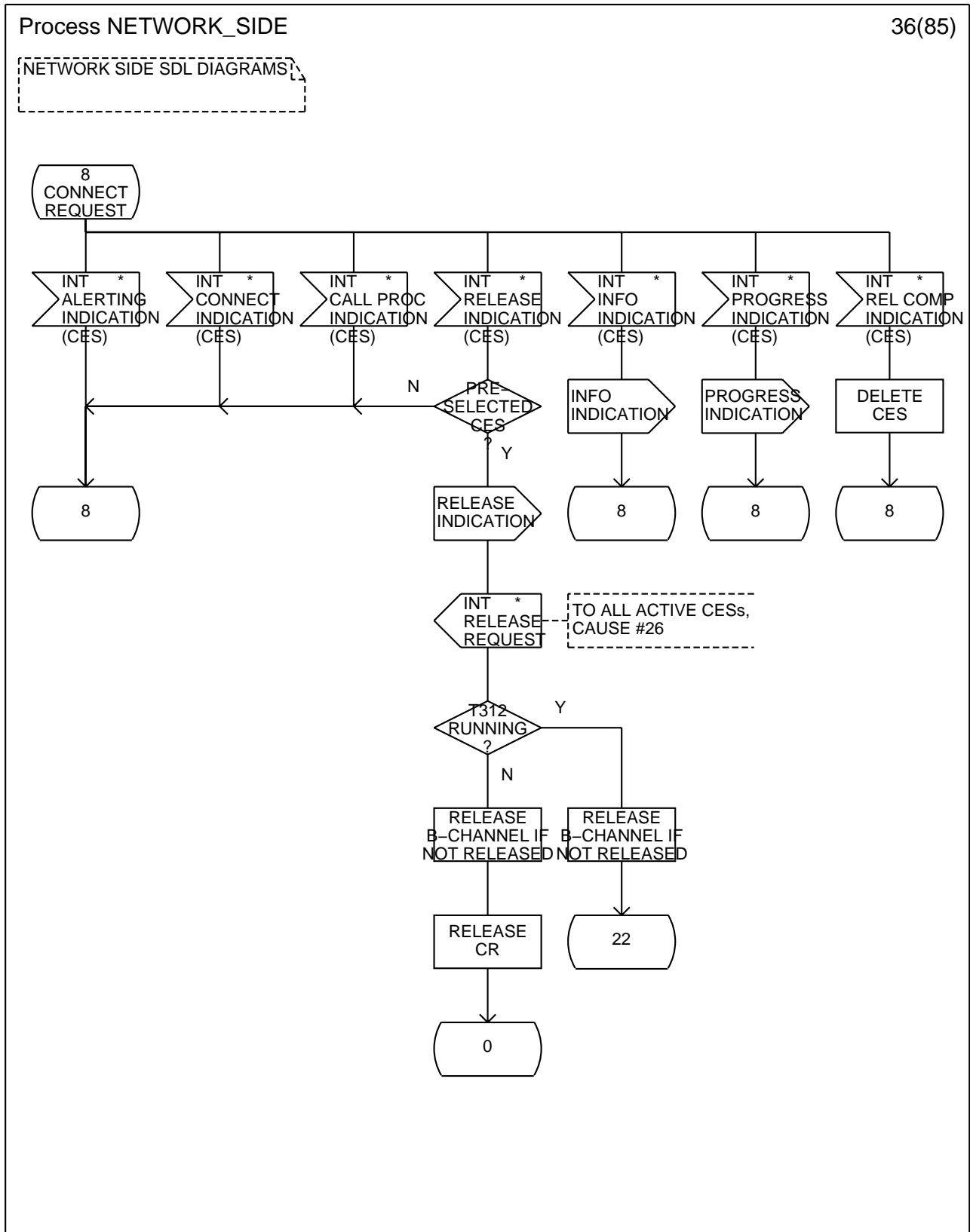

Figure 5 (sheet 36 of 85): Network side SDL diagram

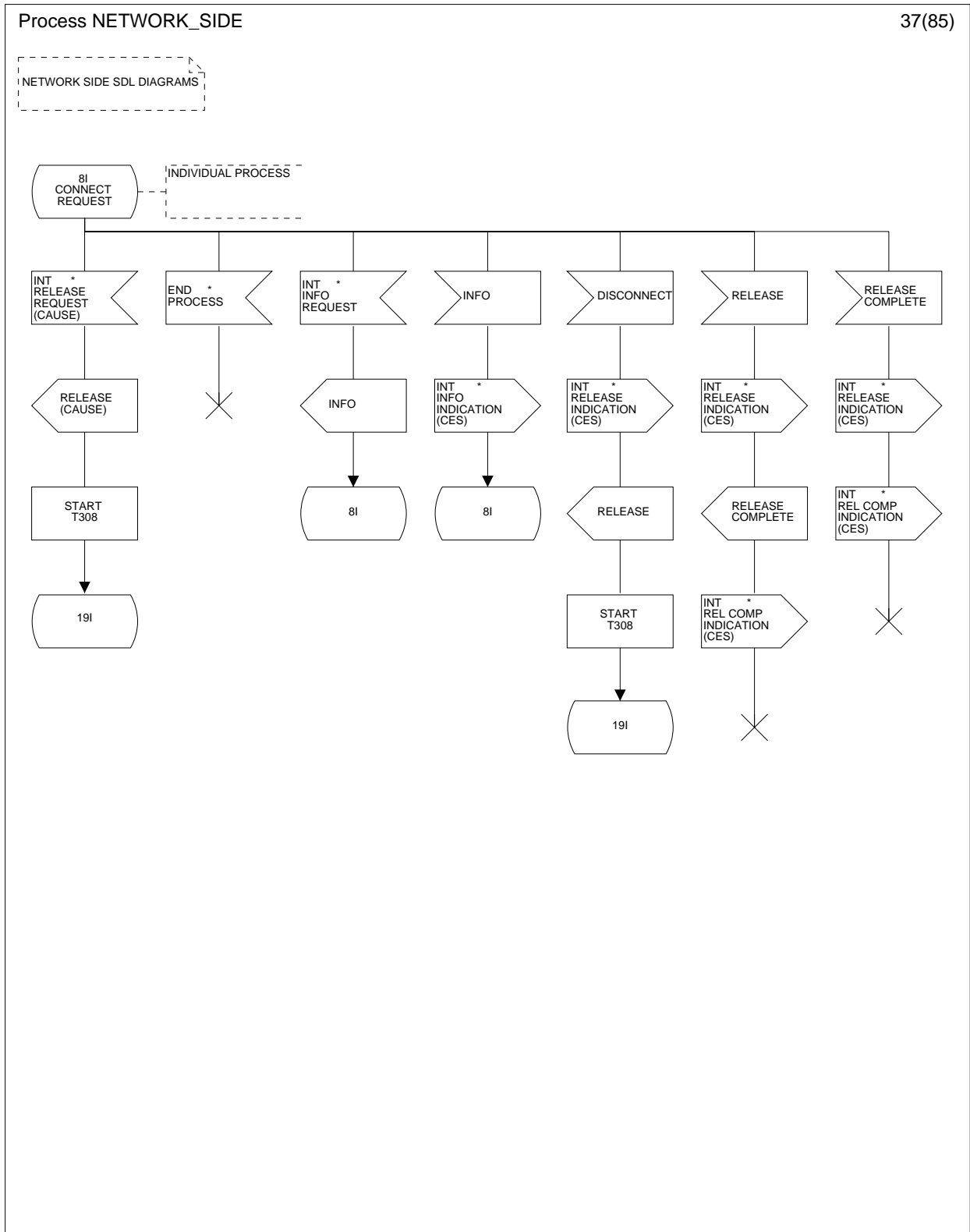

Figure 5 (sheet 37 of 85): Network side SDL diagram

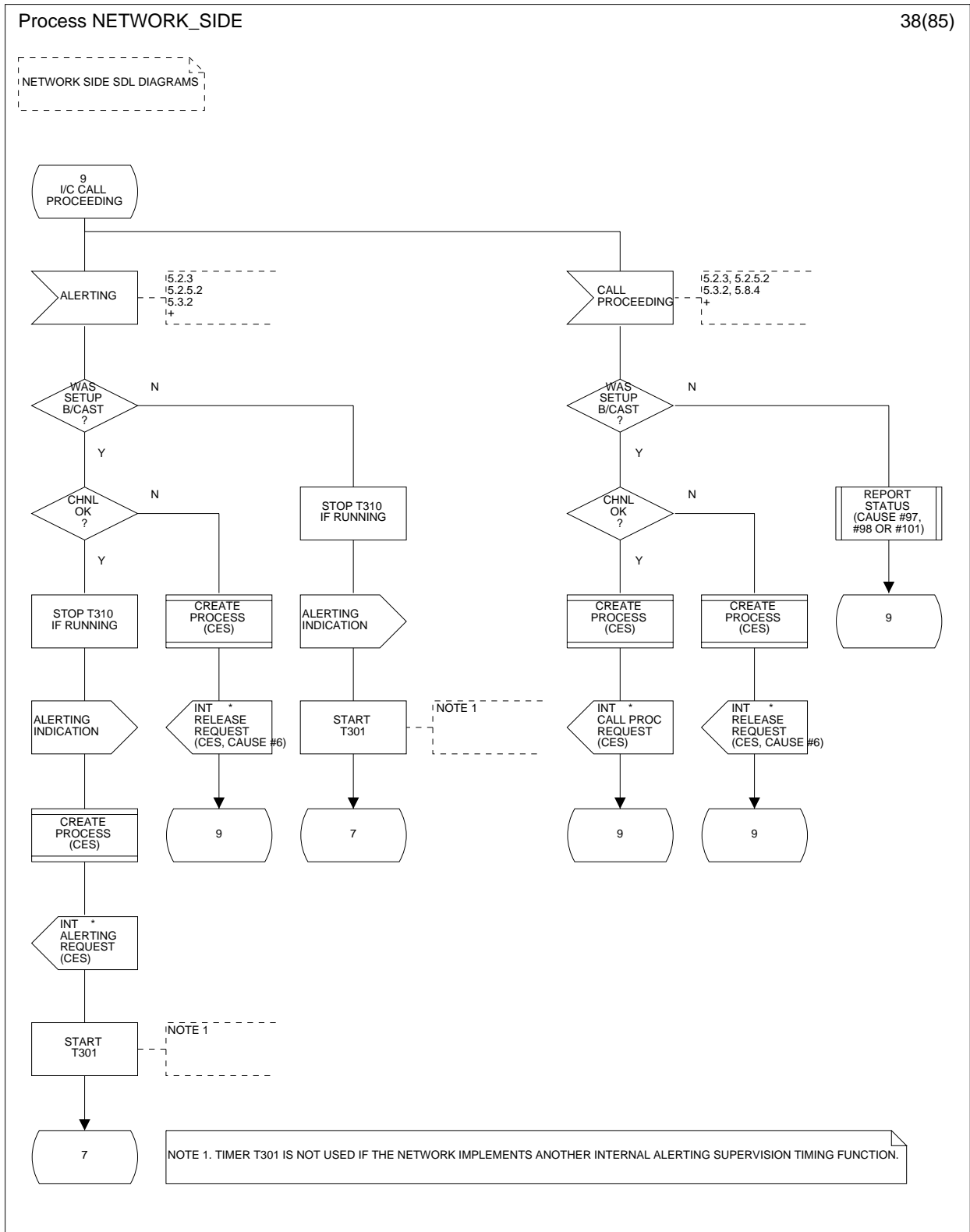

Figure 5 (sheet 38 of 85): Network side SDL diagram

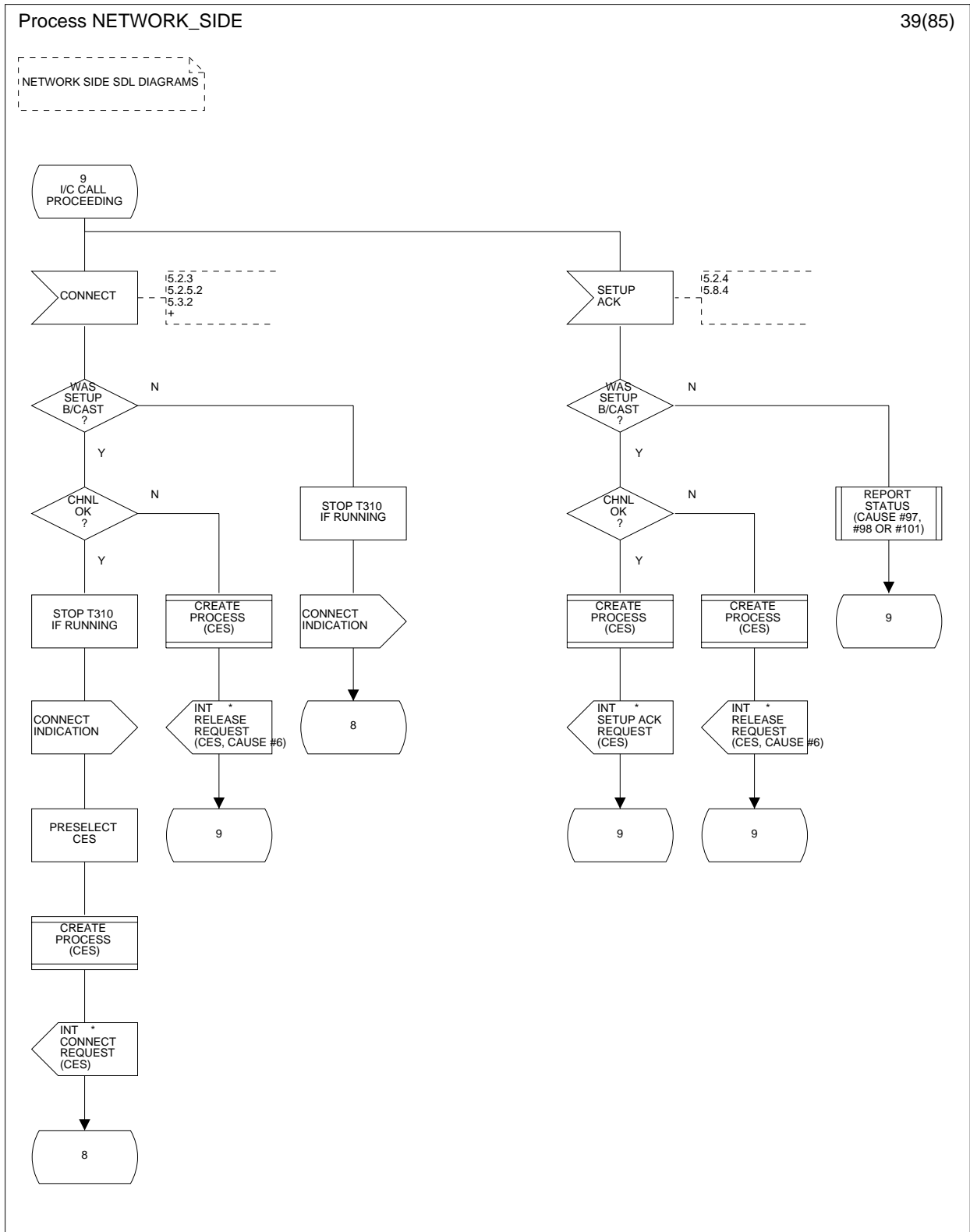

Figure 5 (sheet 39 of 85): Network side SDL diagram

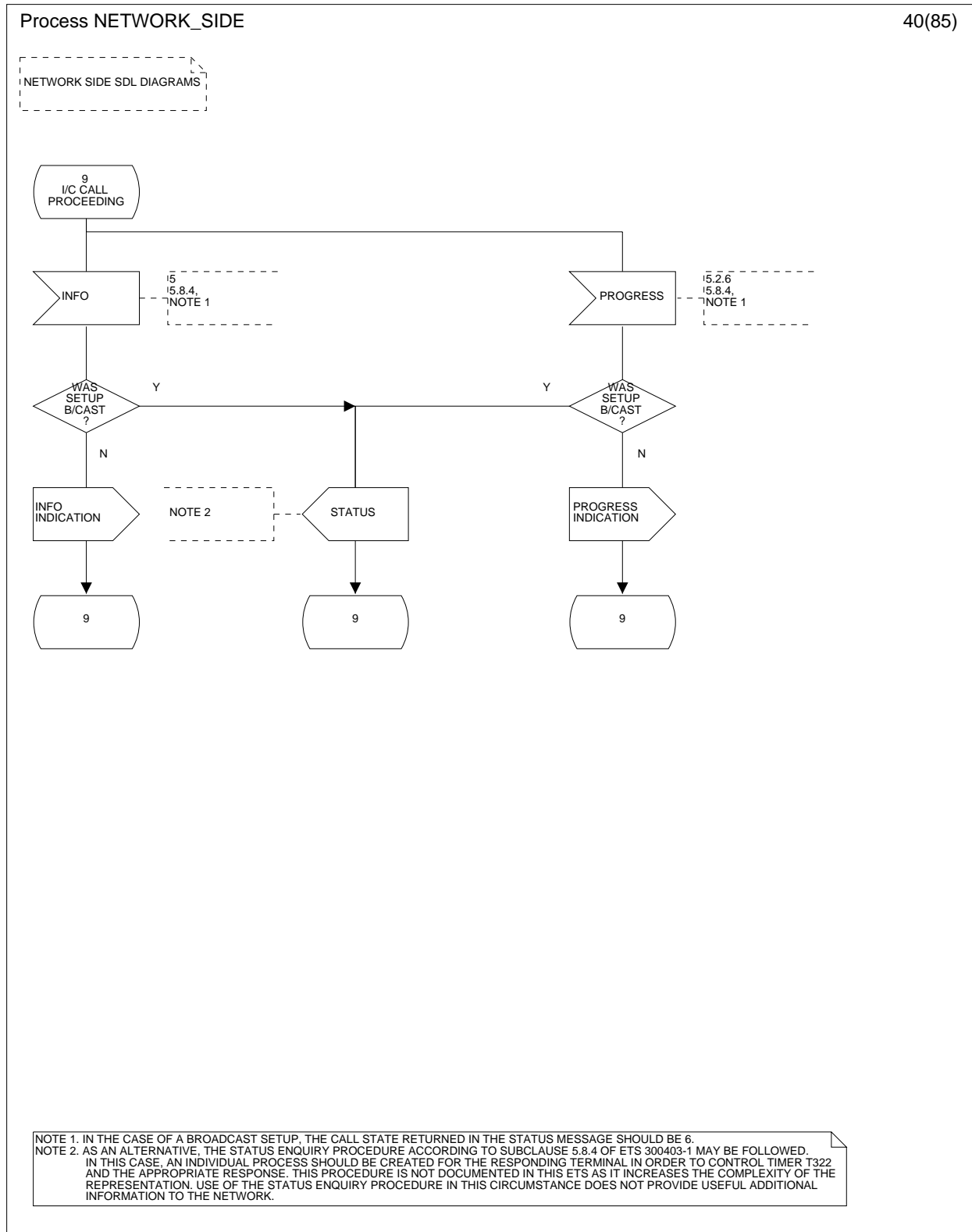

Figure 5 (sheet 40 of 85): Network side SDL diagram



Process NETWORK\_SIDE

41(85)

NETWORK SIDE SDL DIAGRAMS

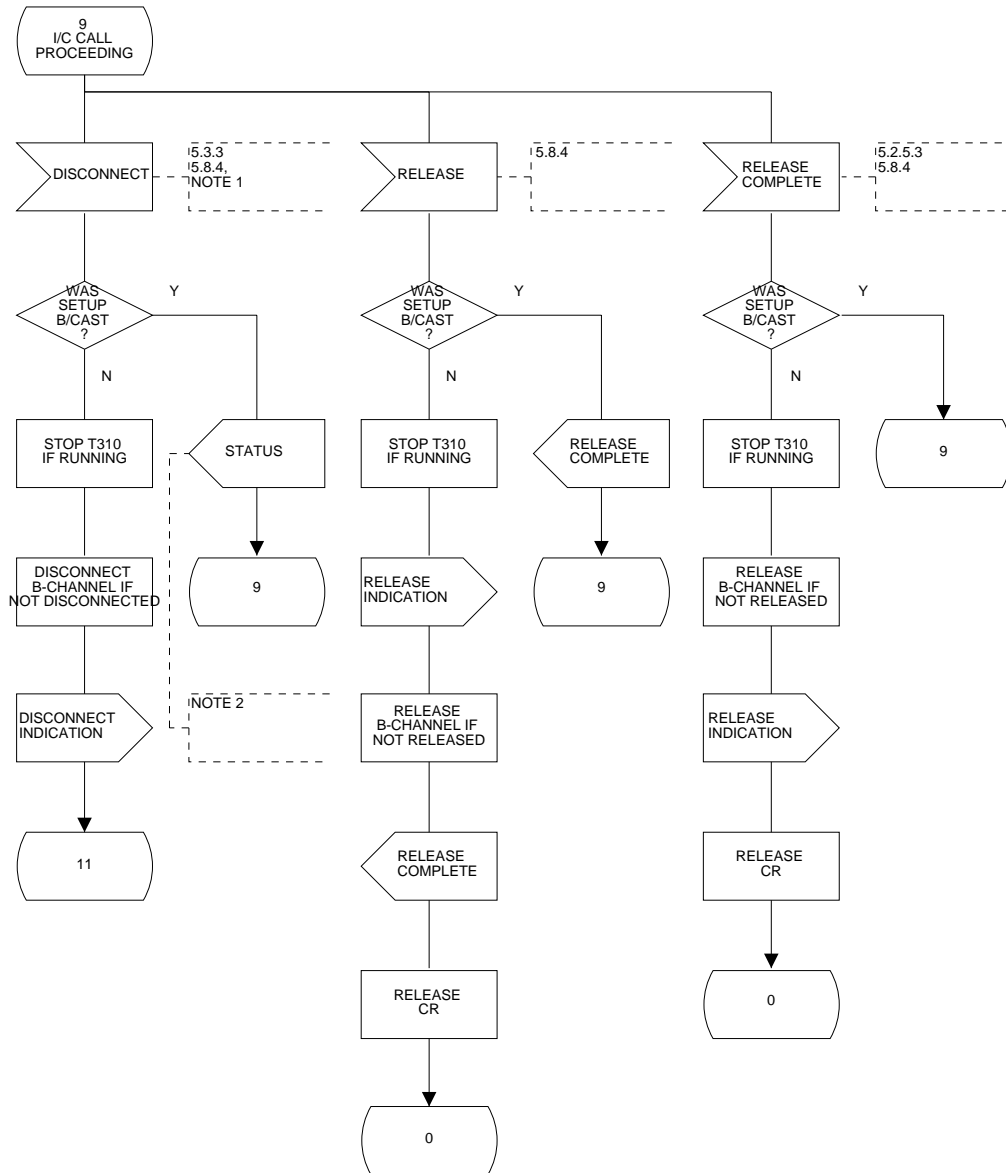

NOTE 1. IN THE CASE OF A BROADCAST SETUP, THE CALL STATE RETURNED IN THE STATUS MESSAGE SHOULD BE 6.  
 NOTE 2. AS AN ALTERNATIVE, A STATUS ENQUIRY PROCEDURE ACCORDING TO SUBCLAUSE 5.8.4 OF ETS 300403-1 MAY BE FOLLOWED. IN THIS CASE, AN INDIVIDUAL PROCESS SHOULD BE CREATED FOR THE RESPONDING TERMINAL IN ORDER TO CONTROL TIMER T322 AND THE APPROPRIATE RESPONSE. THIS PROCEDURE IS NOT DOCUMENTED IN THIS ETS AS IT INCREASES THE COMPLEXITY OF THE REPRESENTATION. USE OF THE STATUS ENQUIRY PROCEDURE IN THIS CIRCUMSTANCE DOES NOT PROVIDE USEFUL ADDITIONAL INFORMATION TO THE NETWORK.

Figure 5 (sheet 41 of 85): Network side SDL diagram

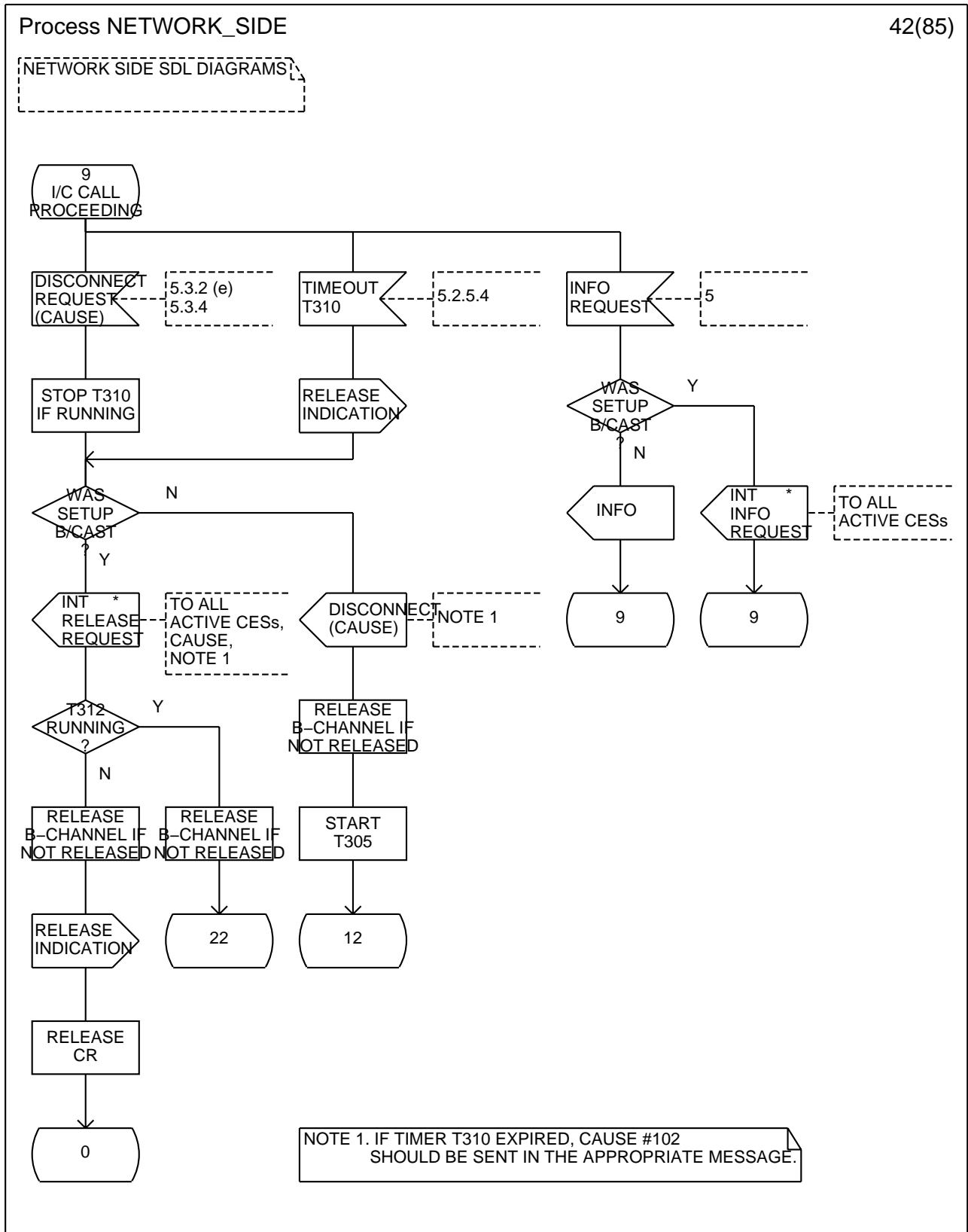

Figure 5 (sheet 42 of 85): Network side SDL diagram

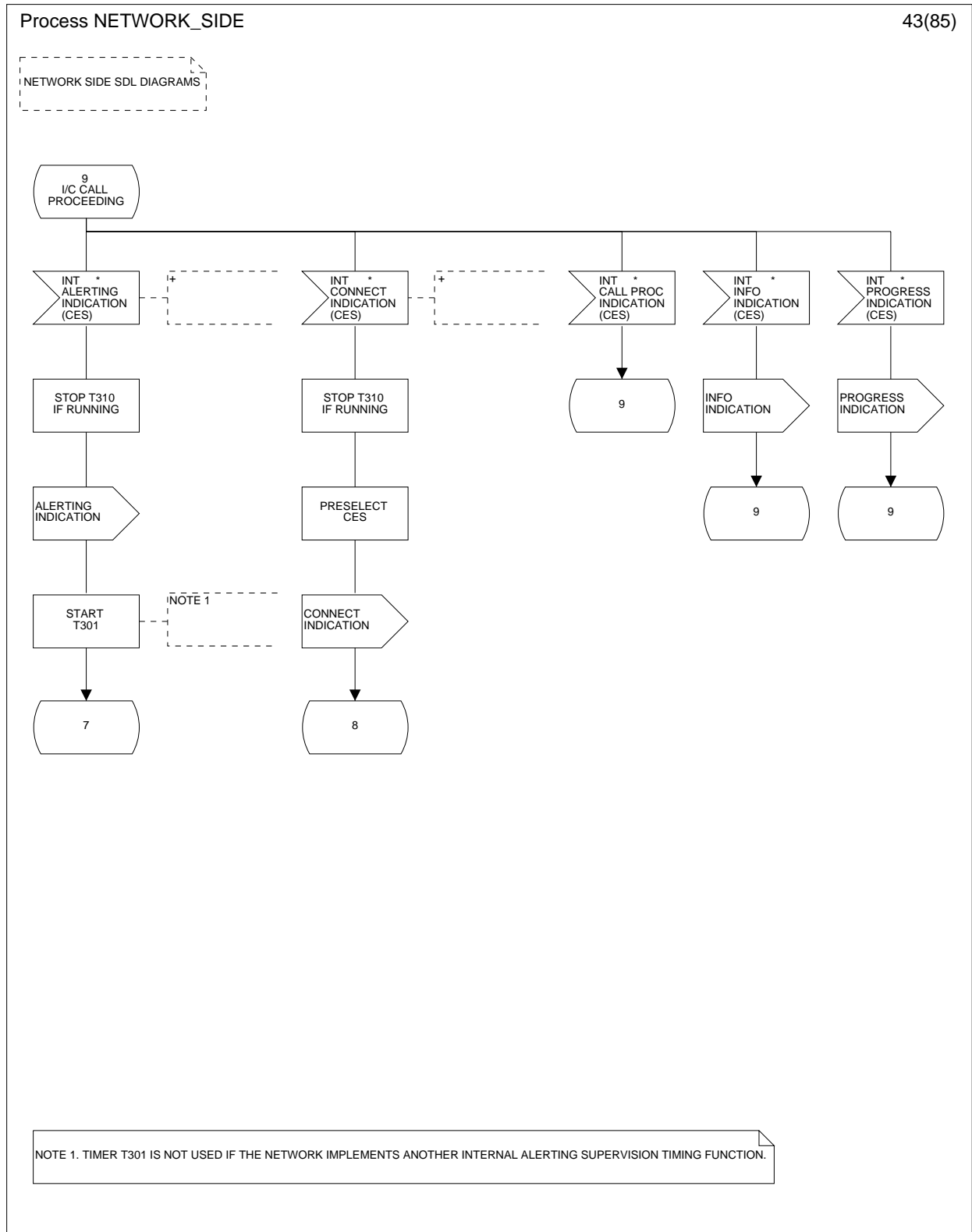

Figure 5 (sheet 43 of 85): Network side SDL diagram

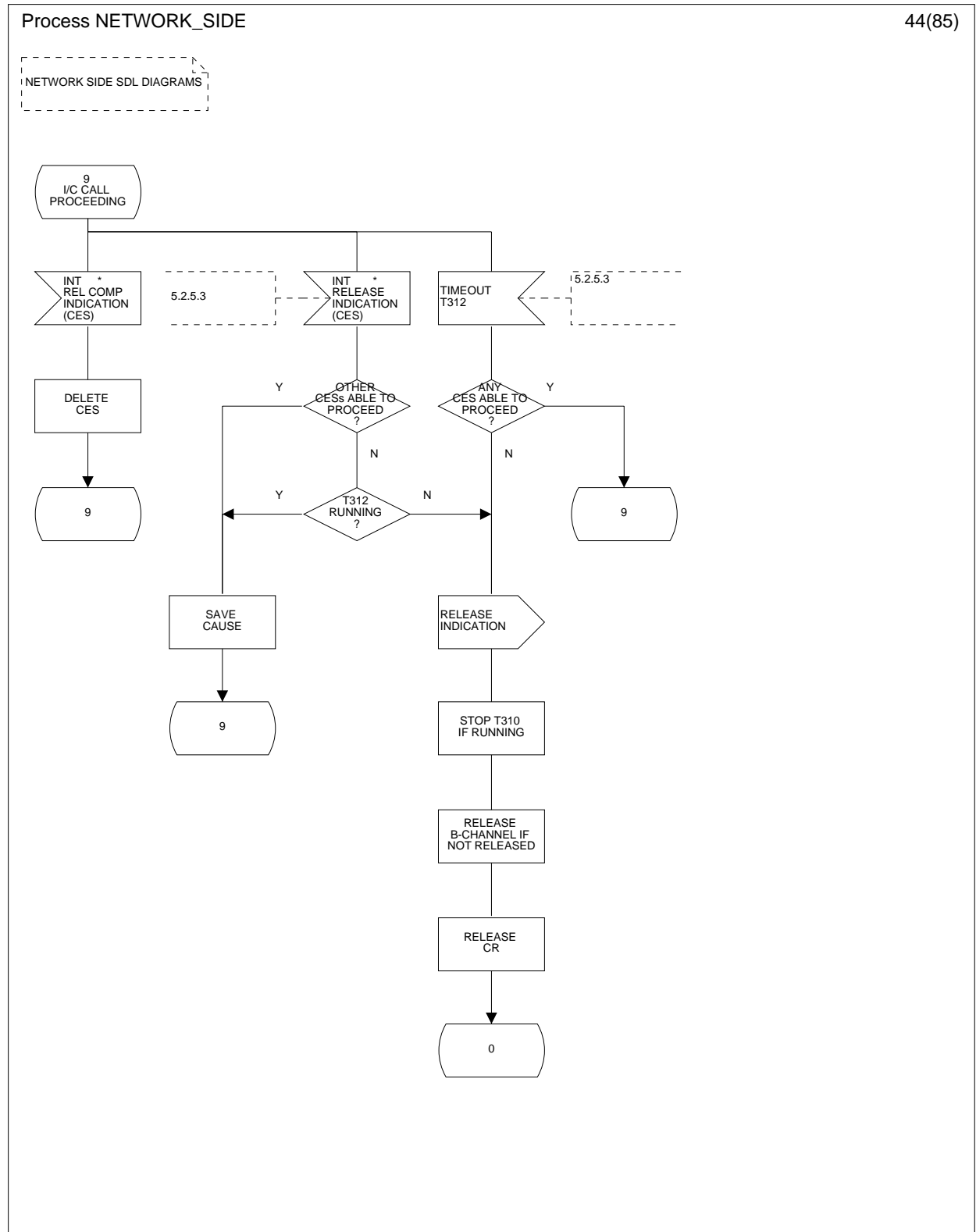

Figure 5 (sheet 44 of 85): Network side SDL diagram

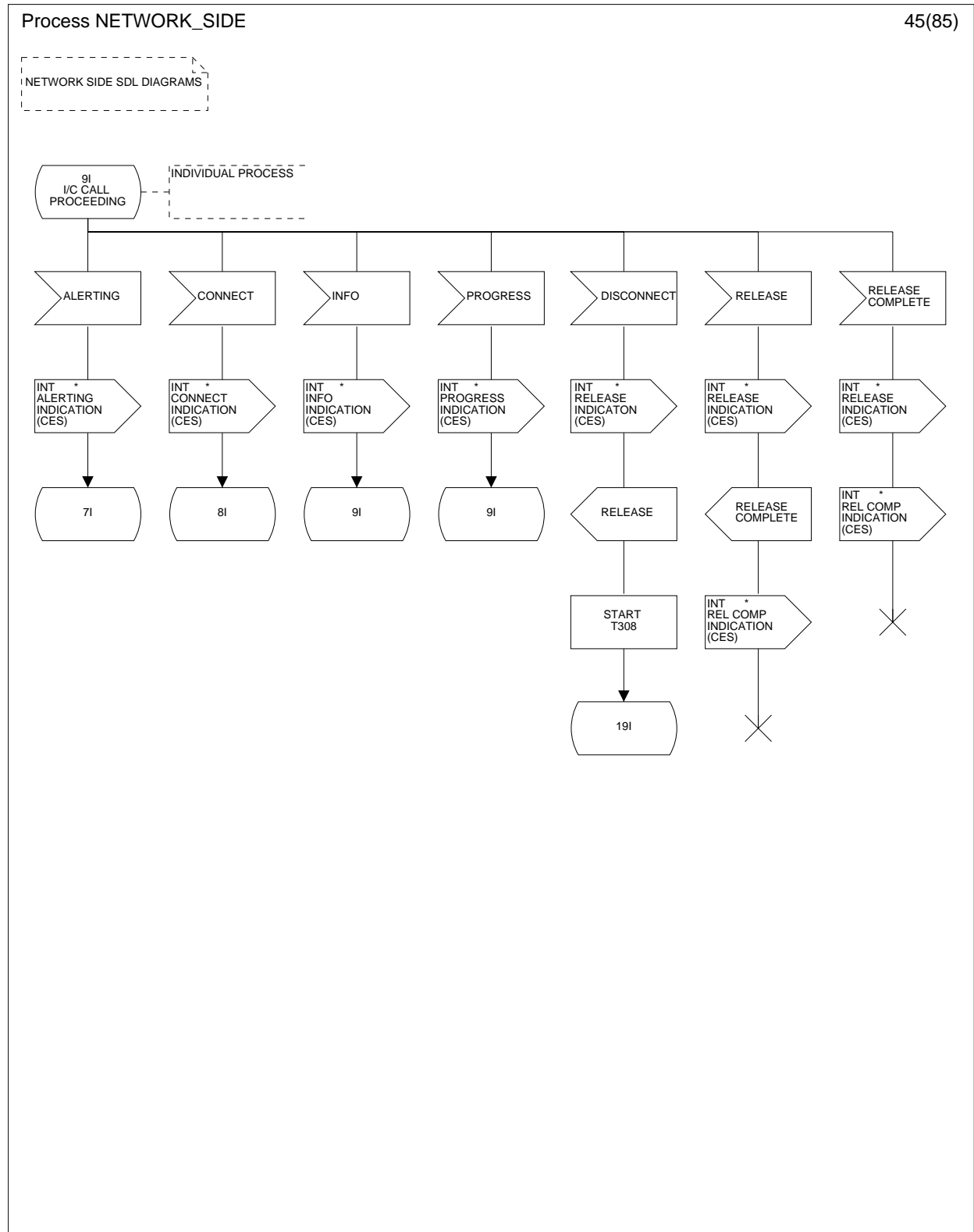

Figure 5 (sheet 45 of 85): Network side SDL diagram

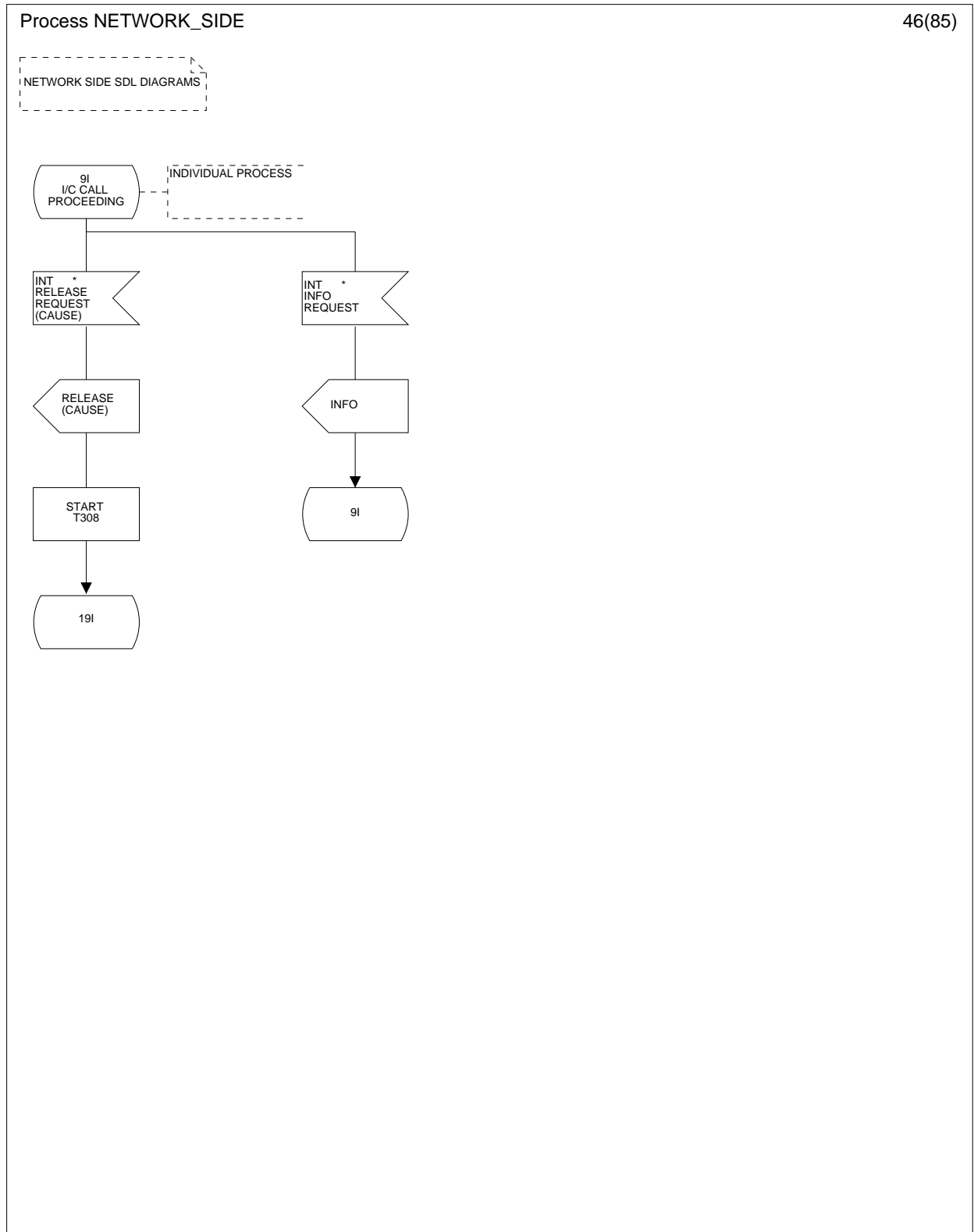

Figure 5 (sheet 46 of 85): Network side SDL diagram

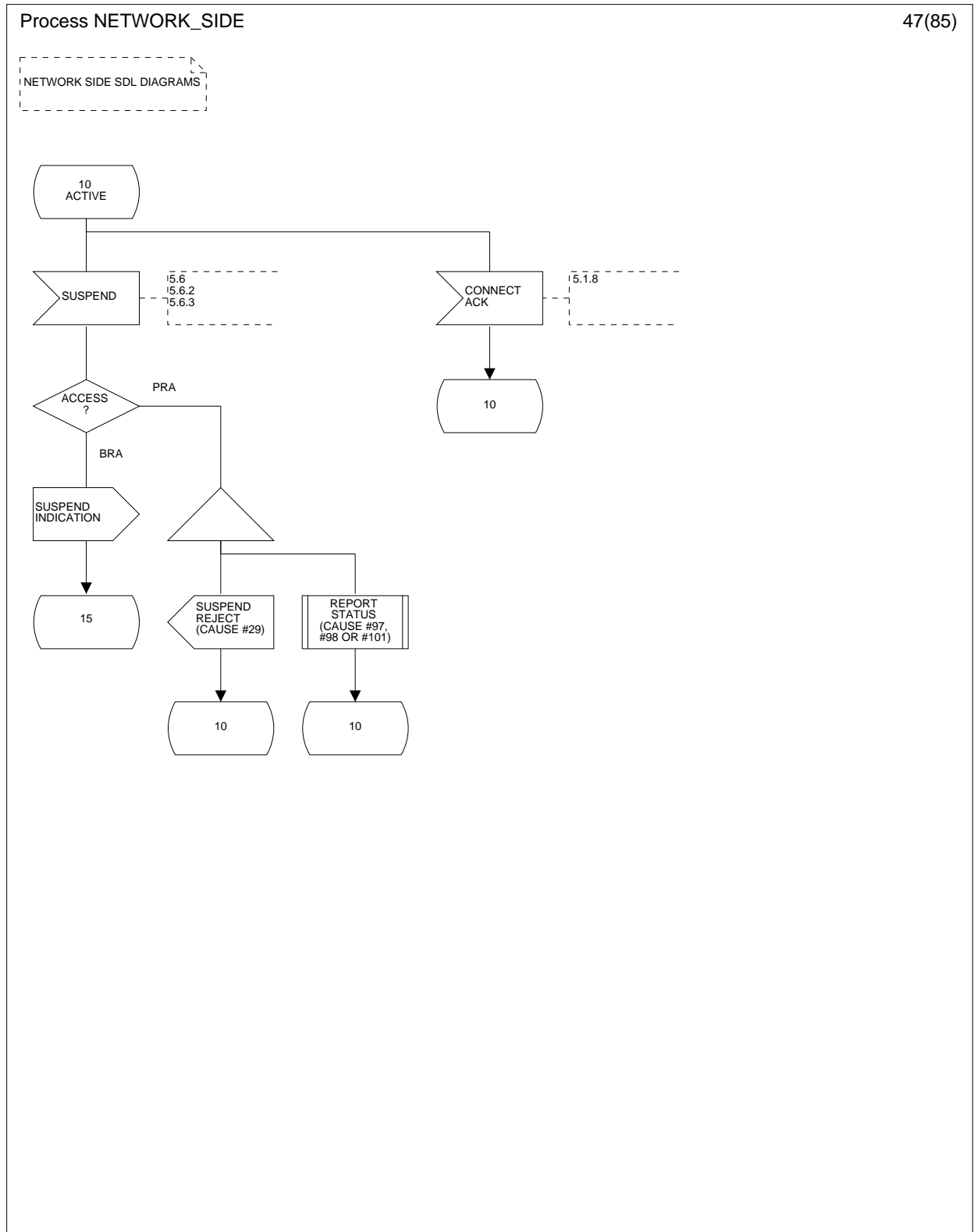

Figure 5 (sheet 47 of 85): Network side SDL diagram

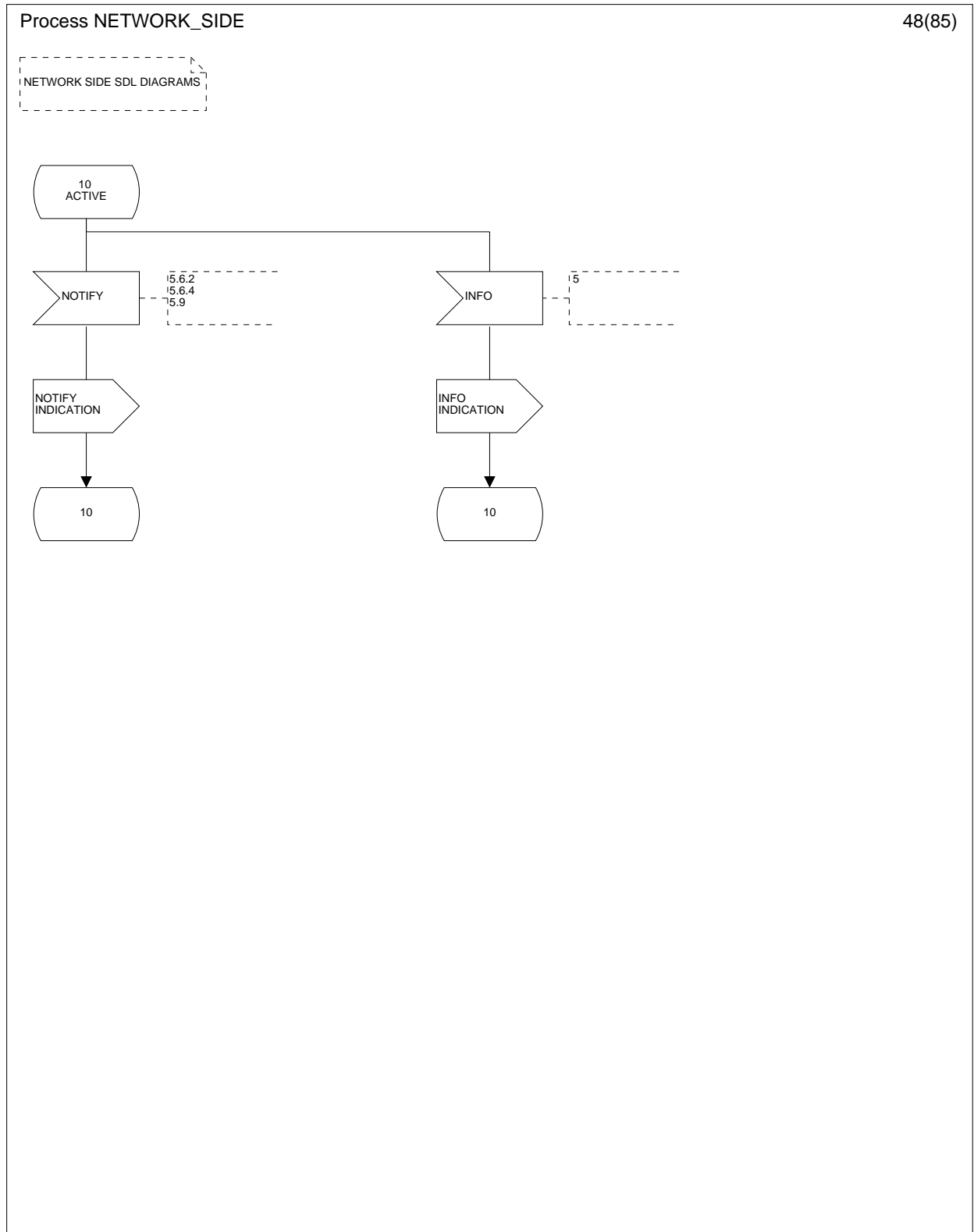

Figure 5 (sheet 48 of 85): Network side SDL diagram



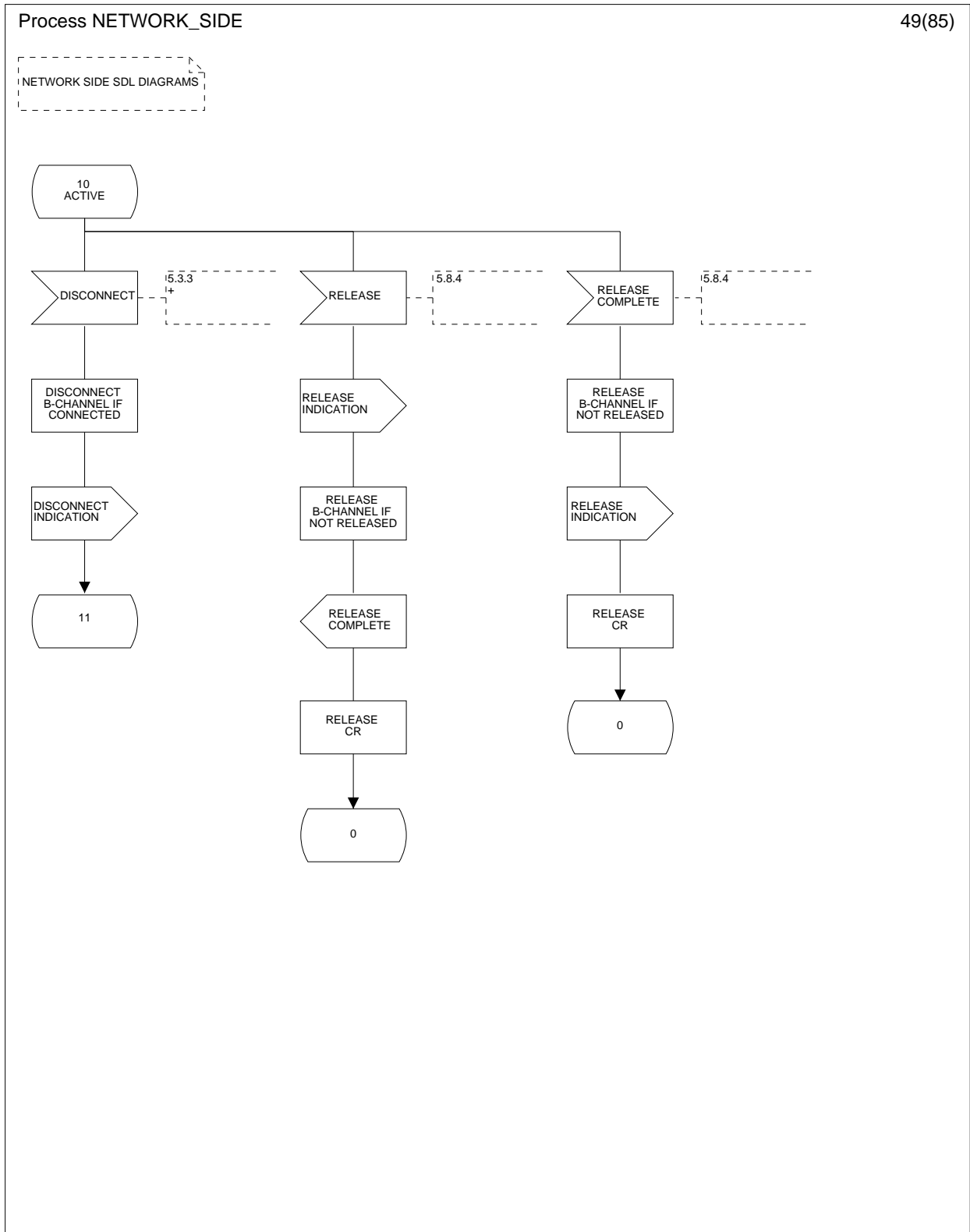

Figure 5 (sheet 49 of 85): Network side SDL diagram

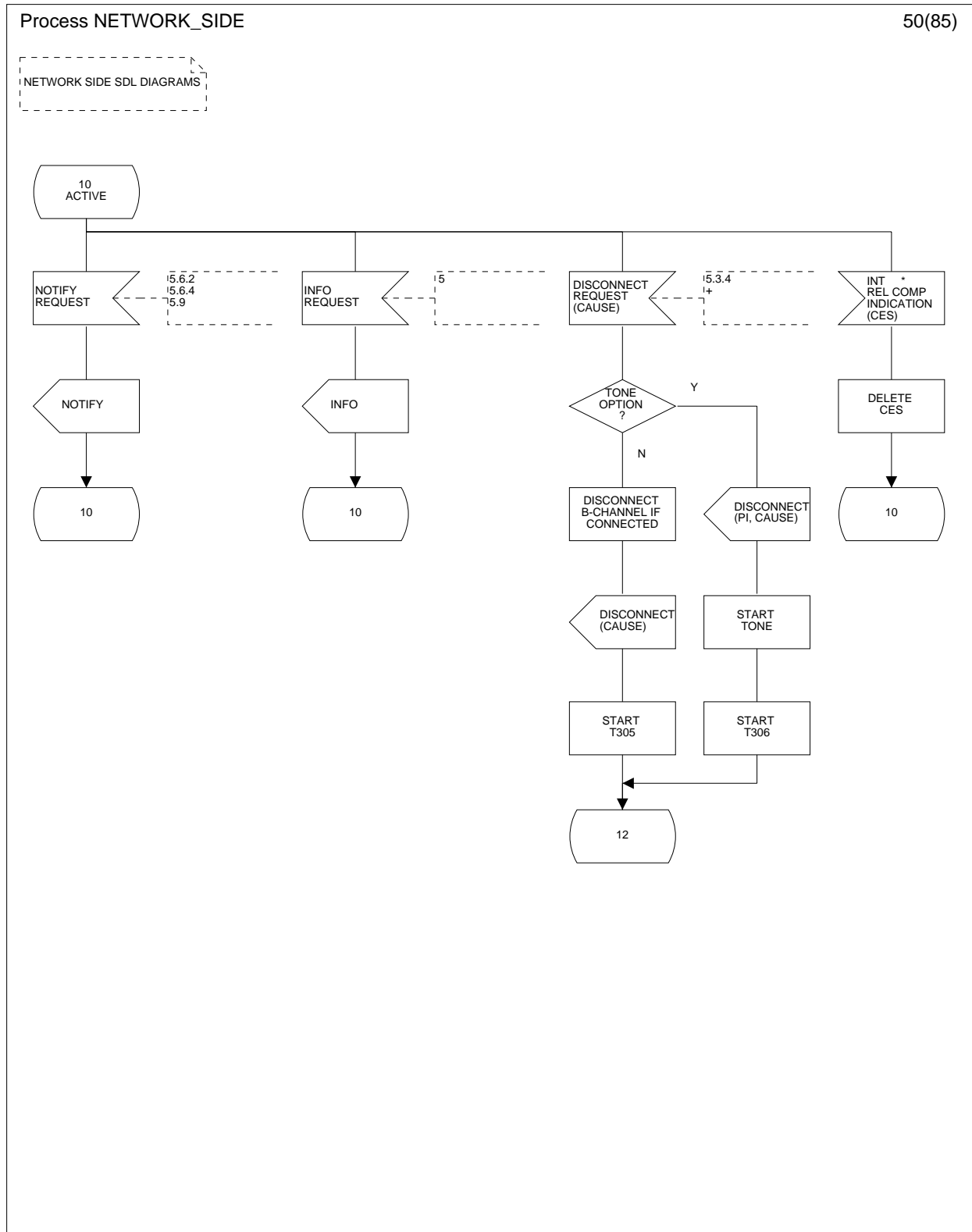

Figure 5 (sheet 50 of 85): Network side SDL diagram

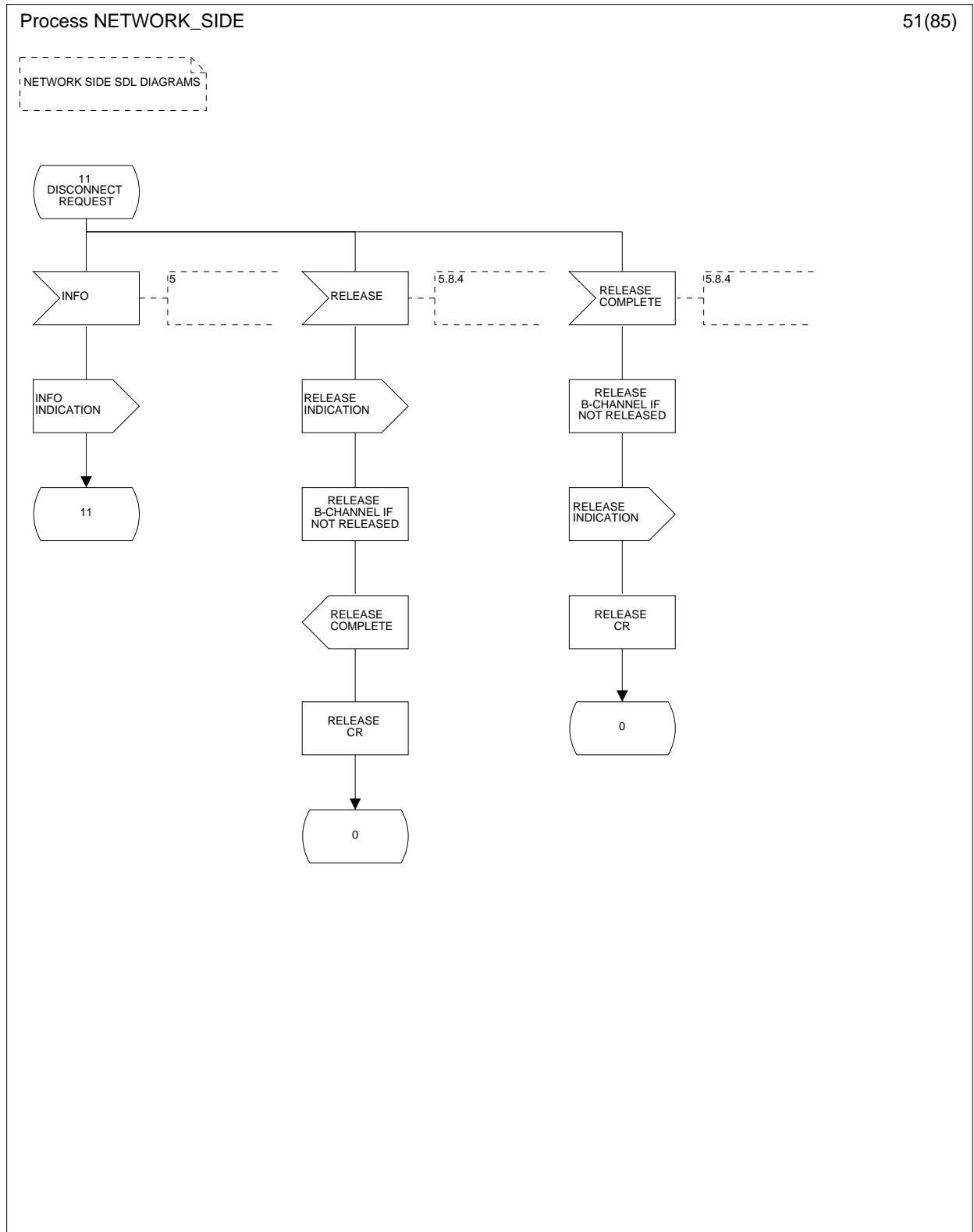

Figure 5 (sheet 51 of 85): Network side SDL diagram

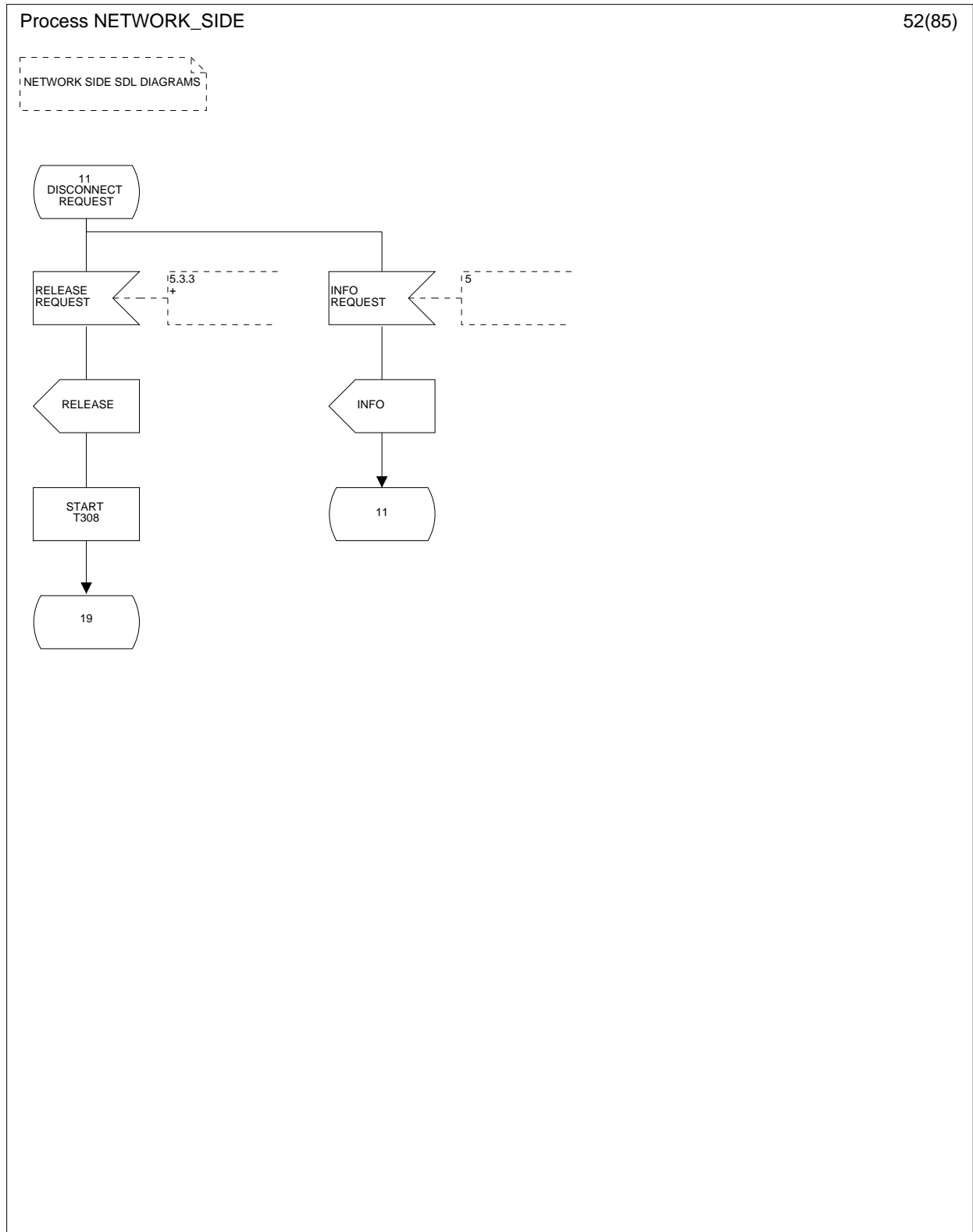

Figure 5 (sheet 52 of 85): Network side SDL diagram

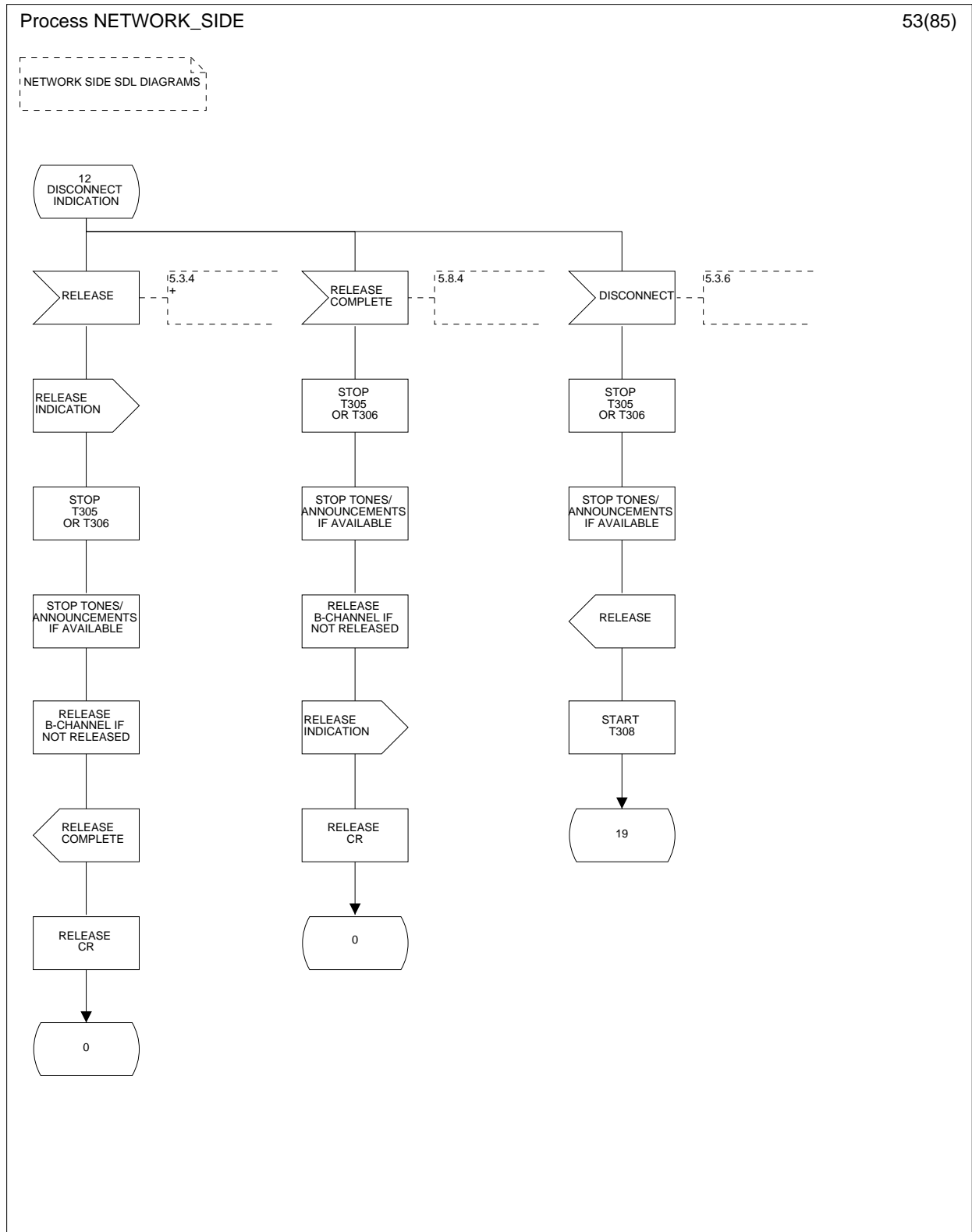

Figure 5 (sheet 53 of 85): Network side SDL diagram

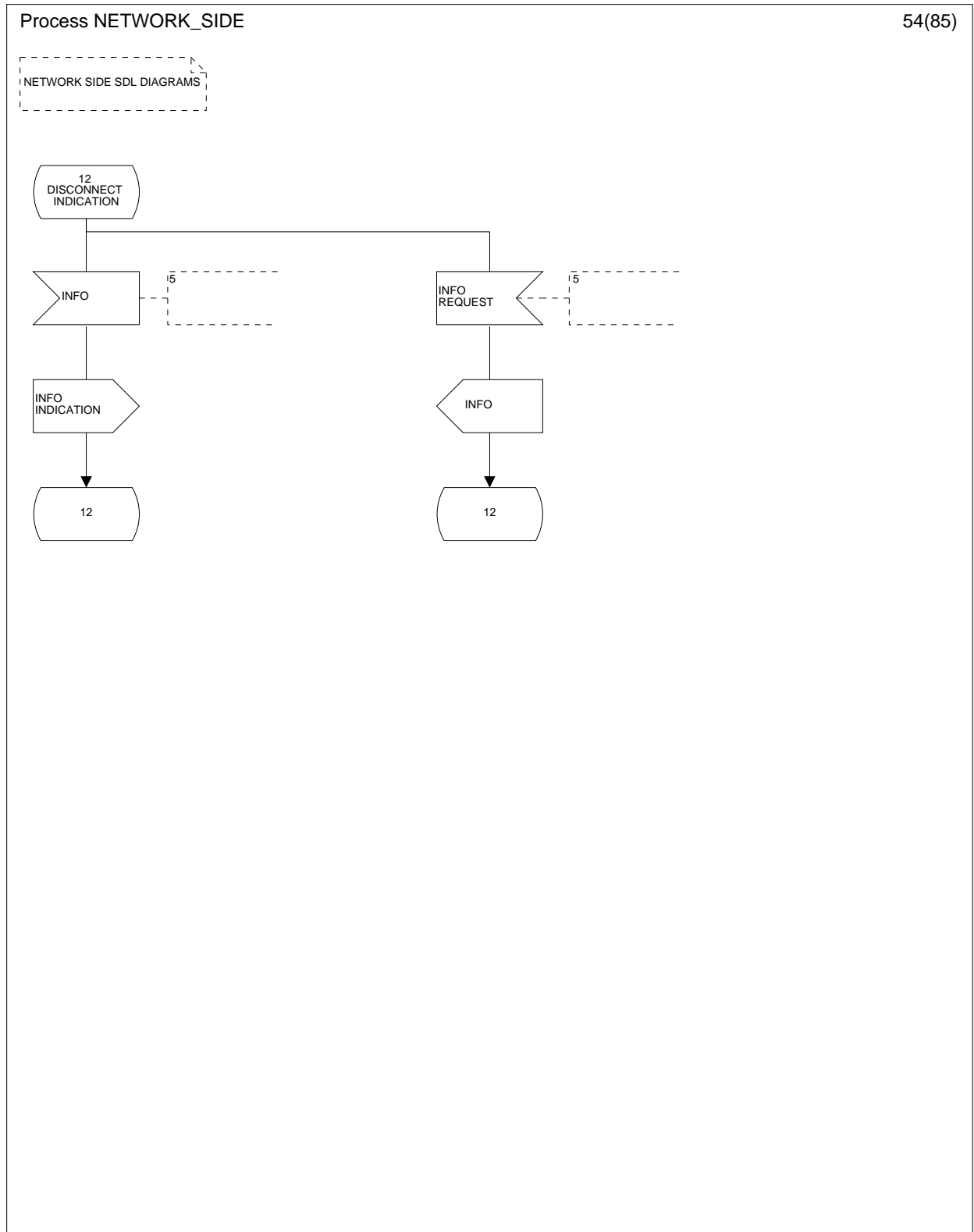

Figure 5 (sheet 54 of 85): Network side SDL diagram

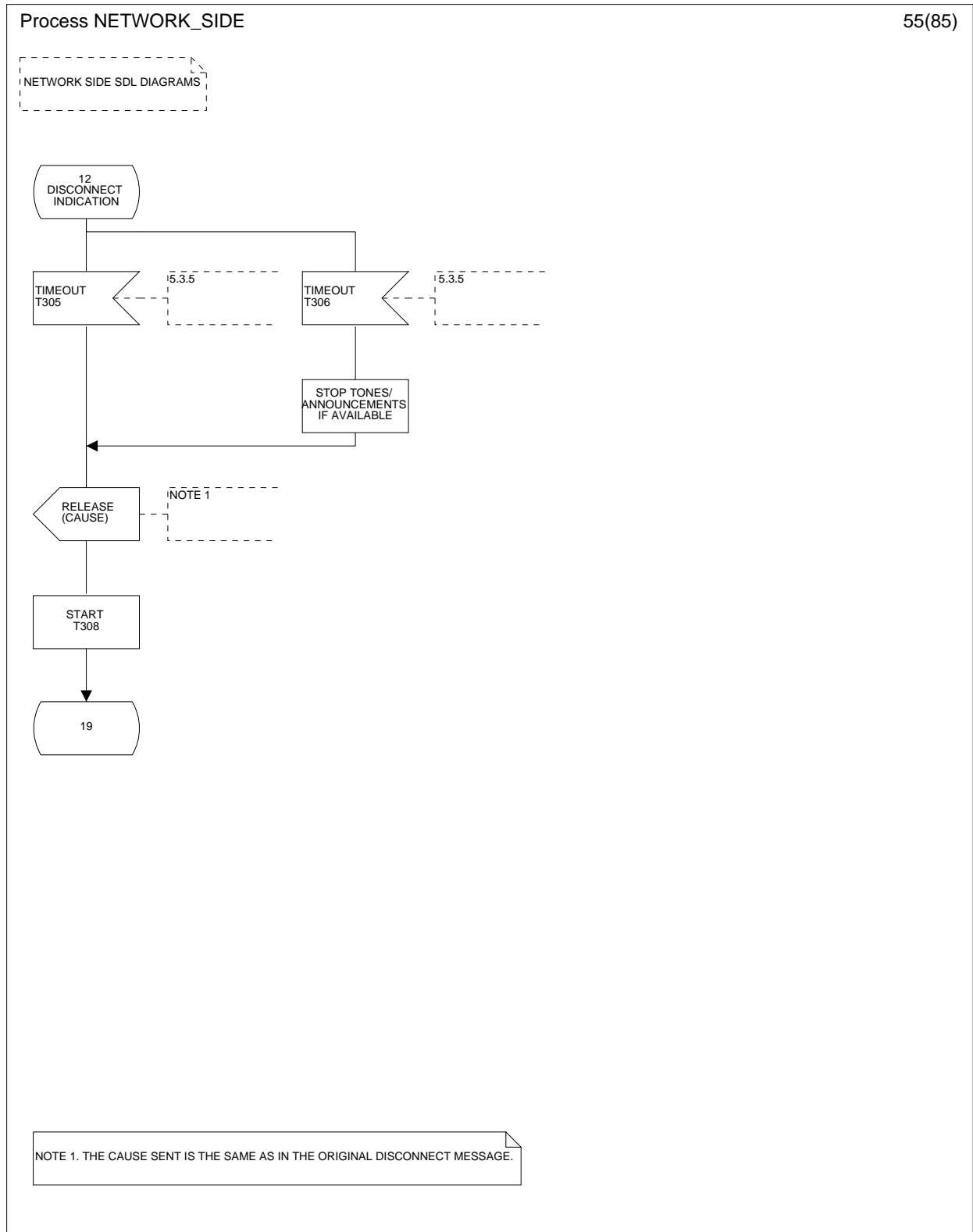

Figure 5 (sheet 55 of 85): Network side SDL diagram

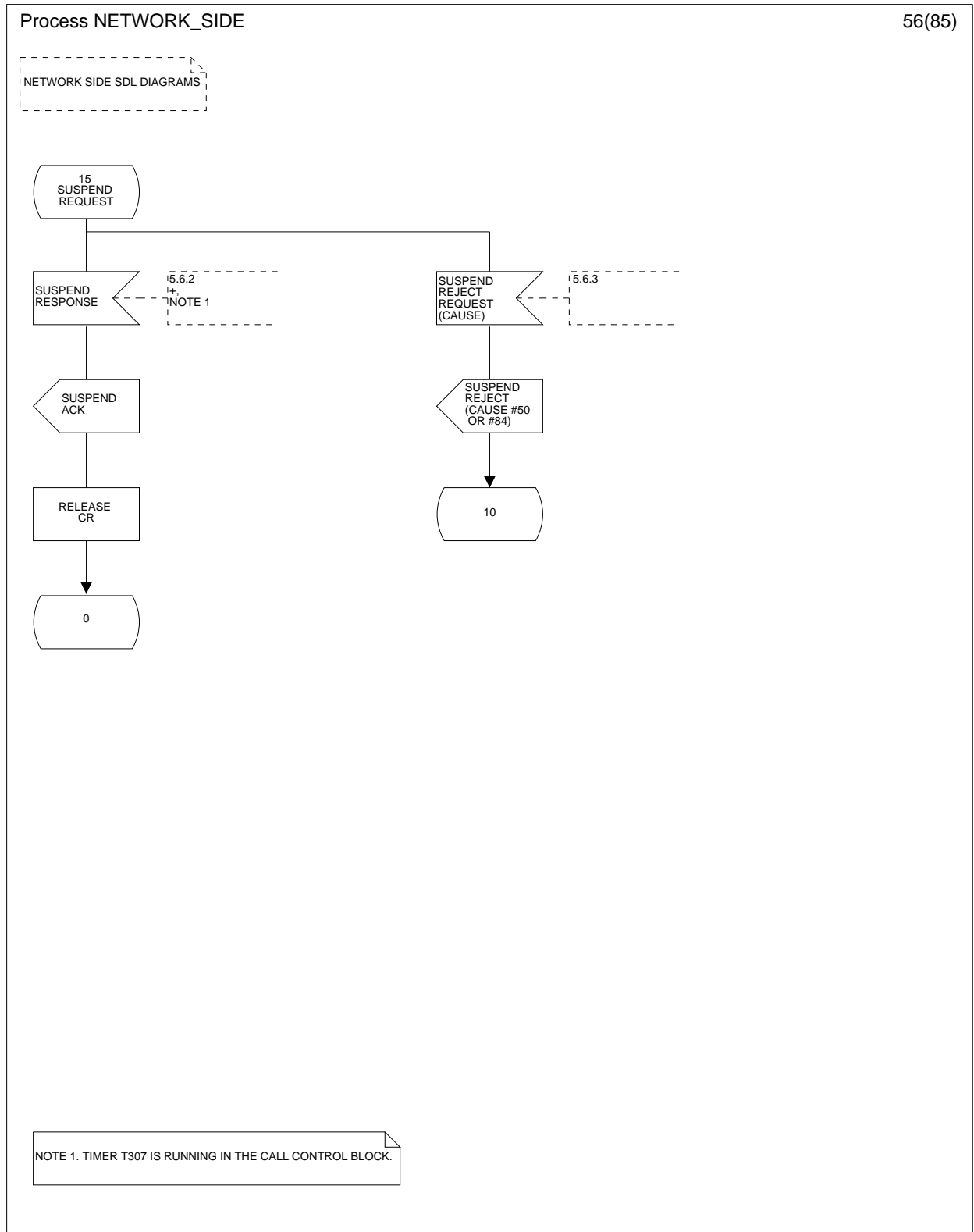

Figure 5 (sheet 56 of 85): Network side SDL diagram



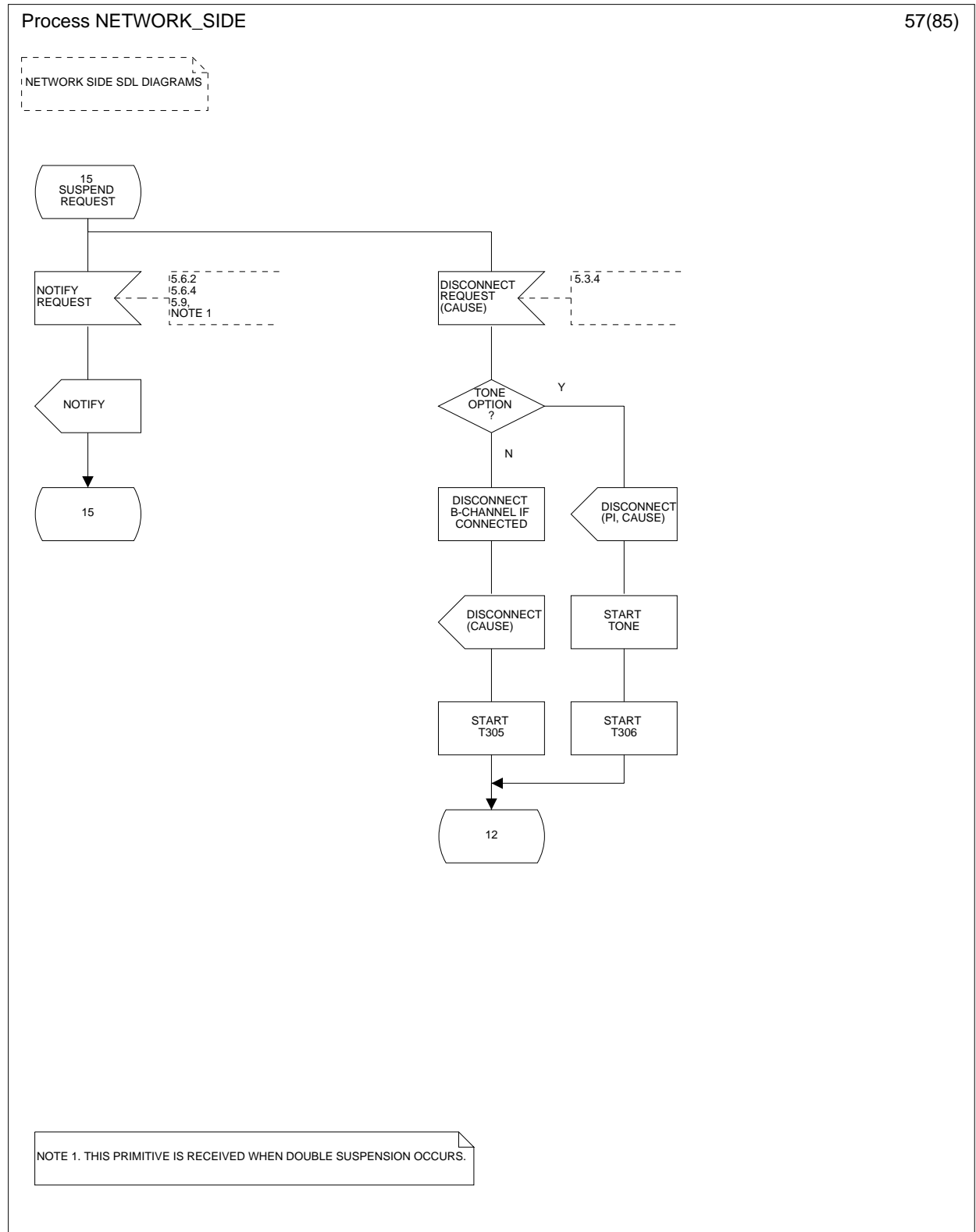

Figure 5 (sheet 57 of 85): Network side SDL diagram

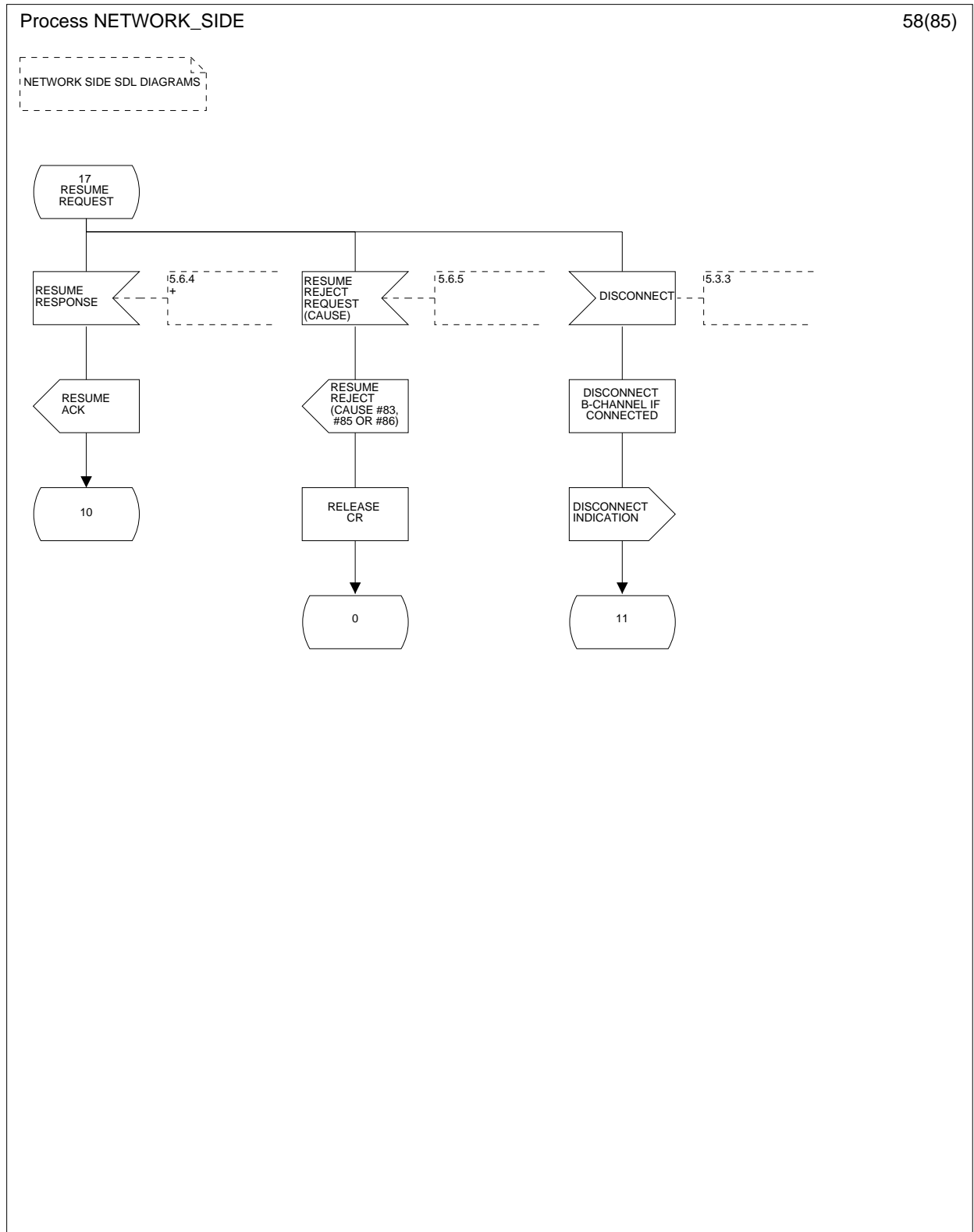

Figure 5 (sheet 58 of 85): Network side SDL diagram

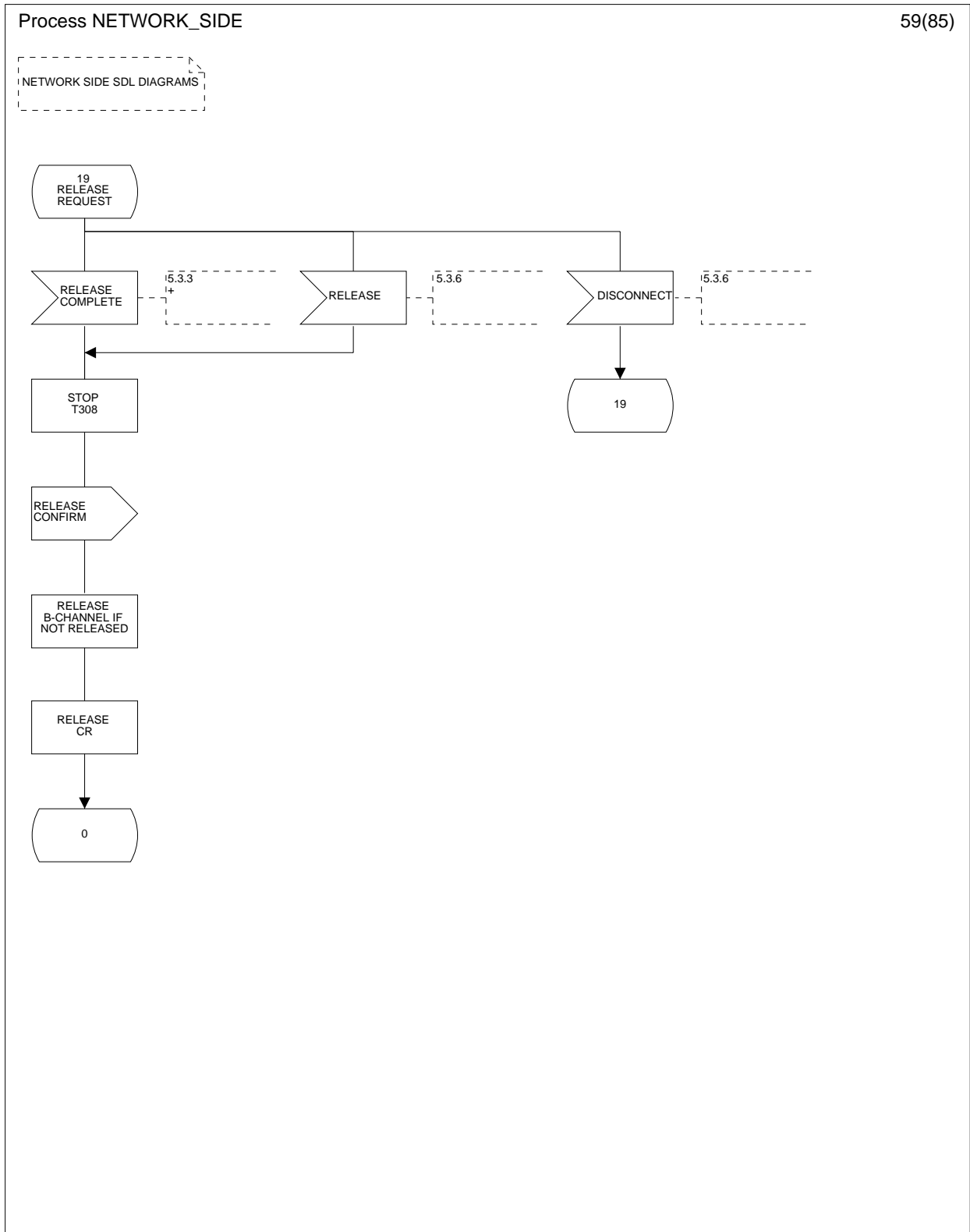

Figure 5 (sheet 59 of 85): Network side SDL diagram

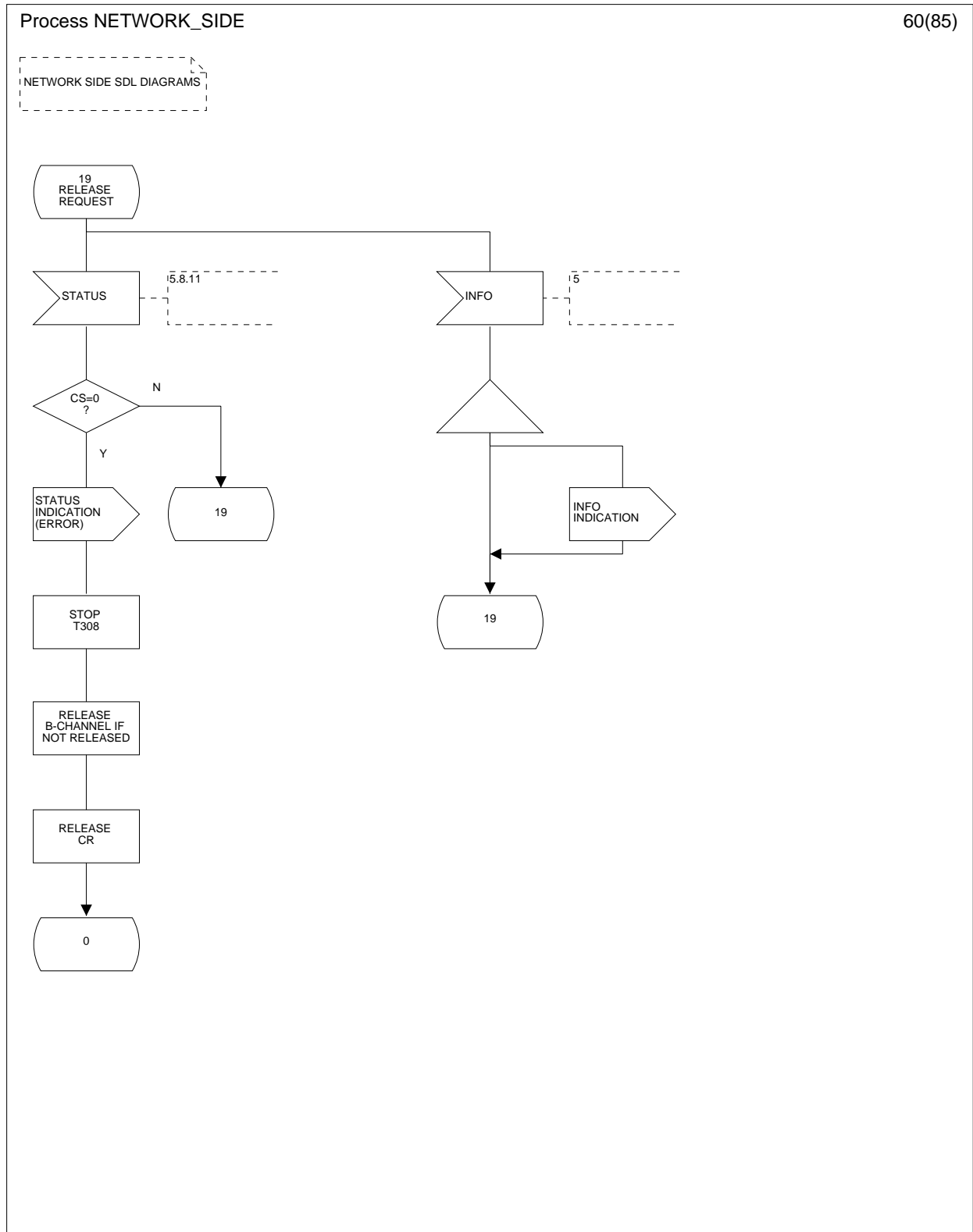

Figure 5 (sheet 60 of 85): Network side SDL diagram

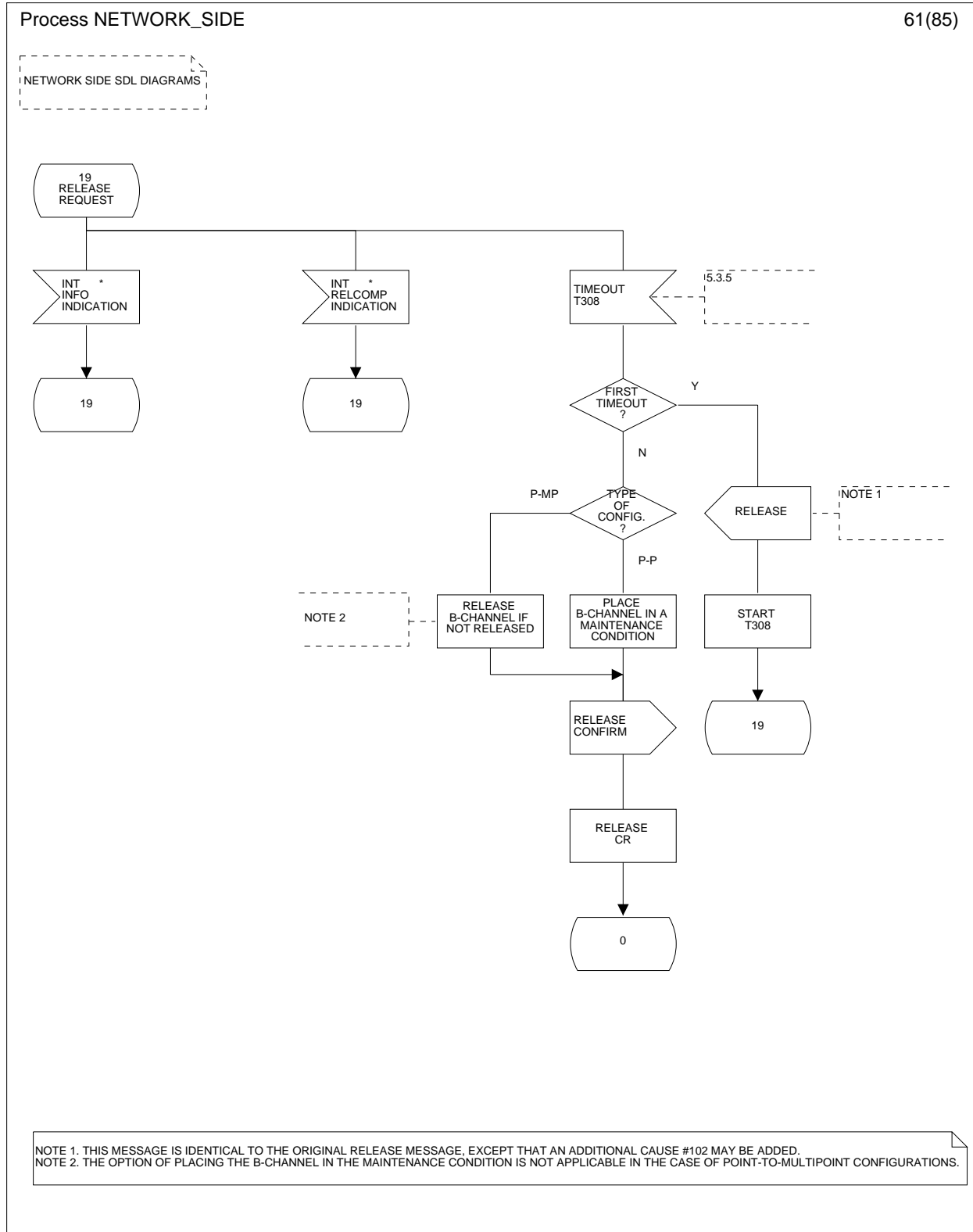

Figure 5 (sheet 61 of 85): Network side SDL diagram

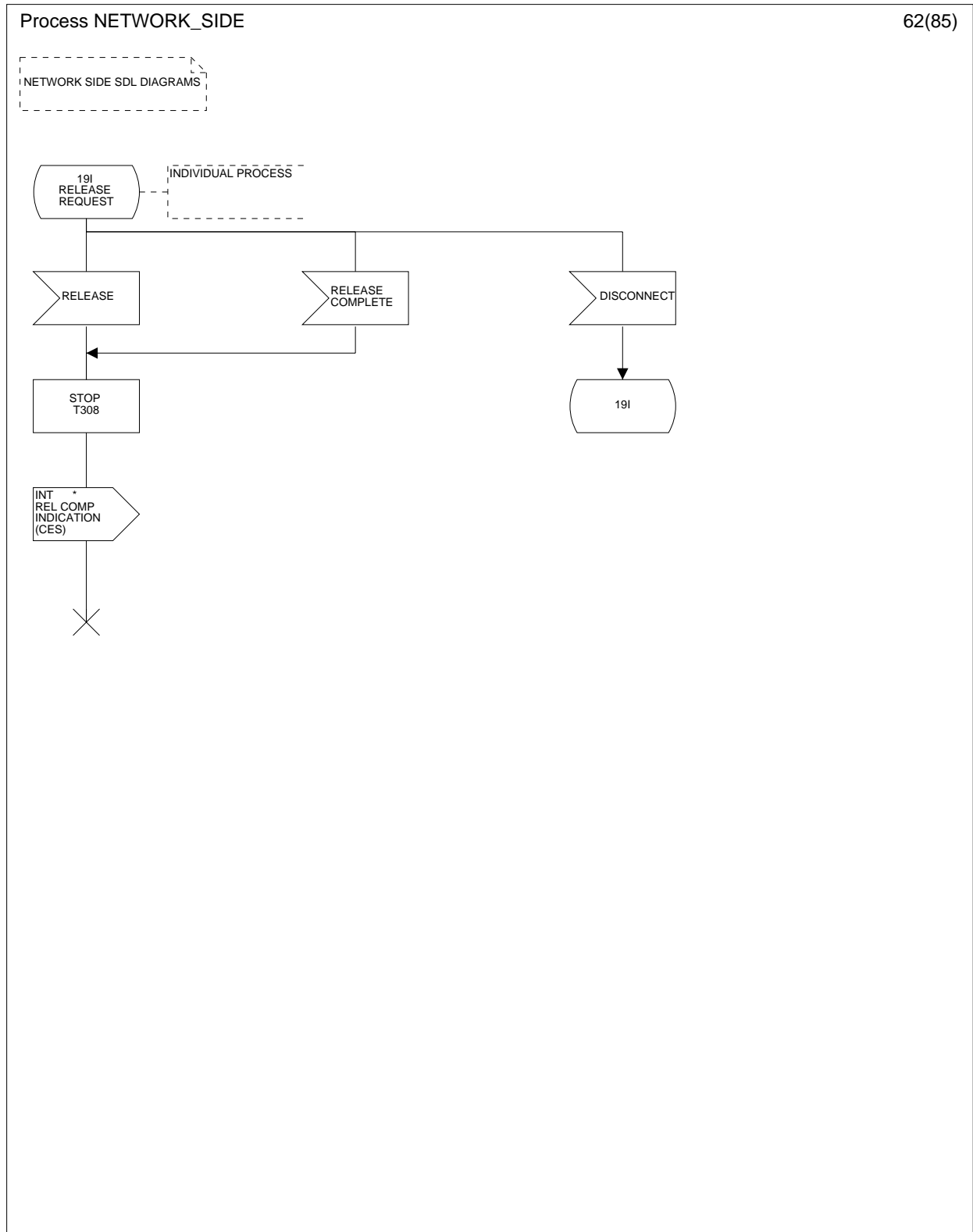

Figure 5 (sheet 62 of 85): Network side SDL diagram

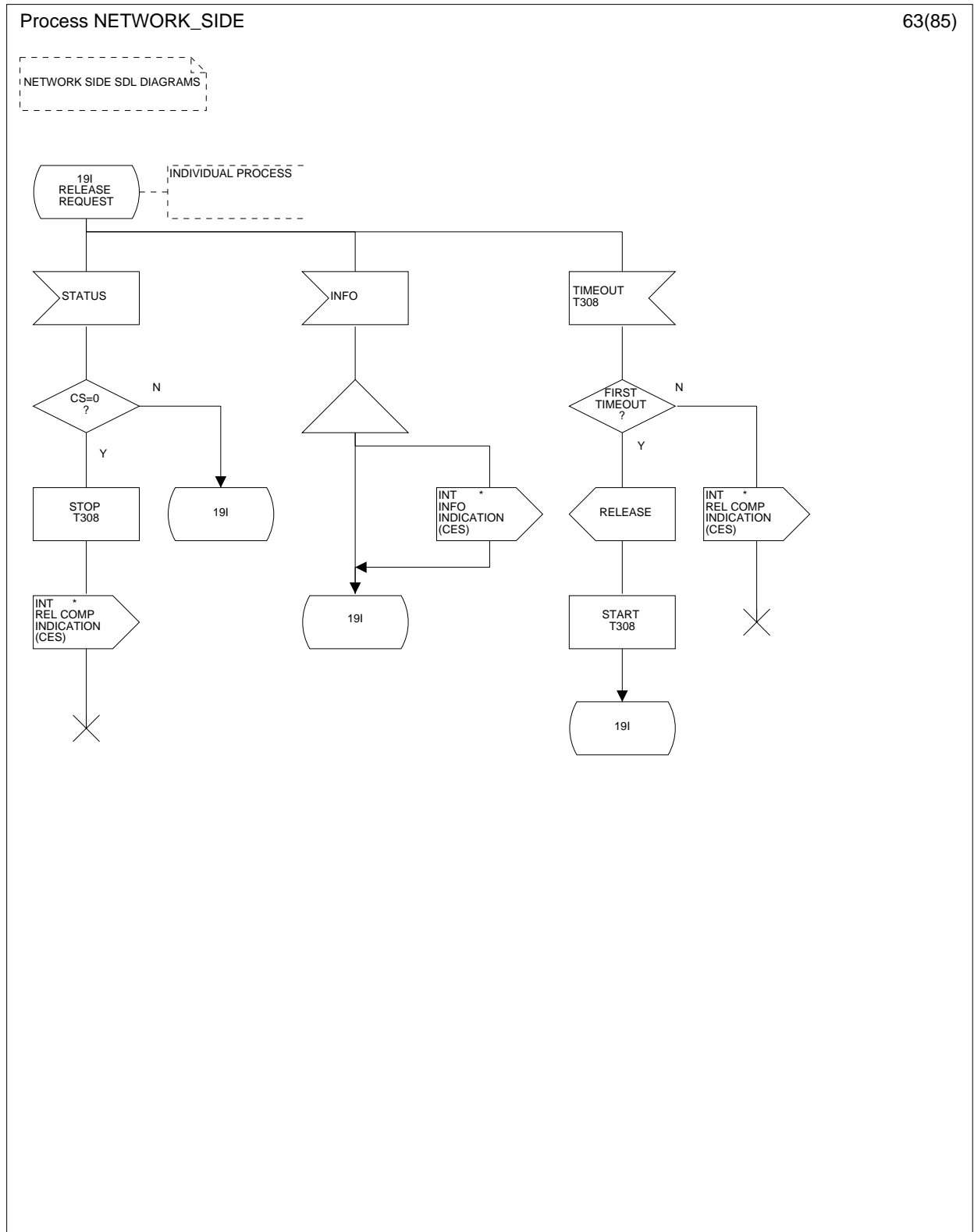

Figure 5 (sheet 63 of 85): Network side SDL diagram

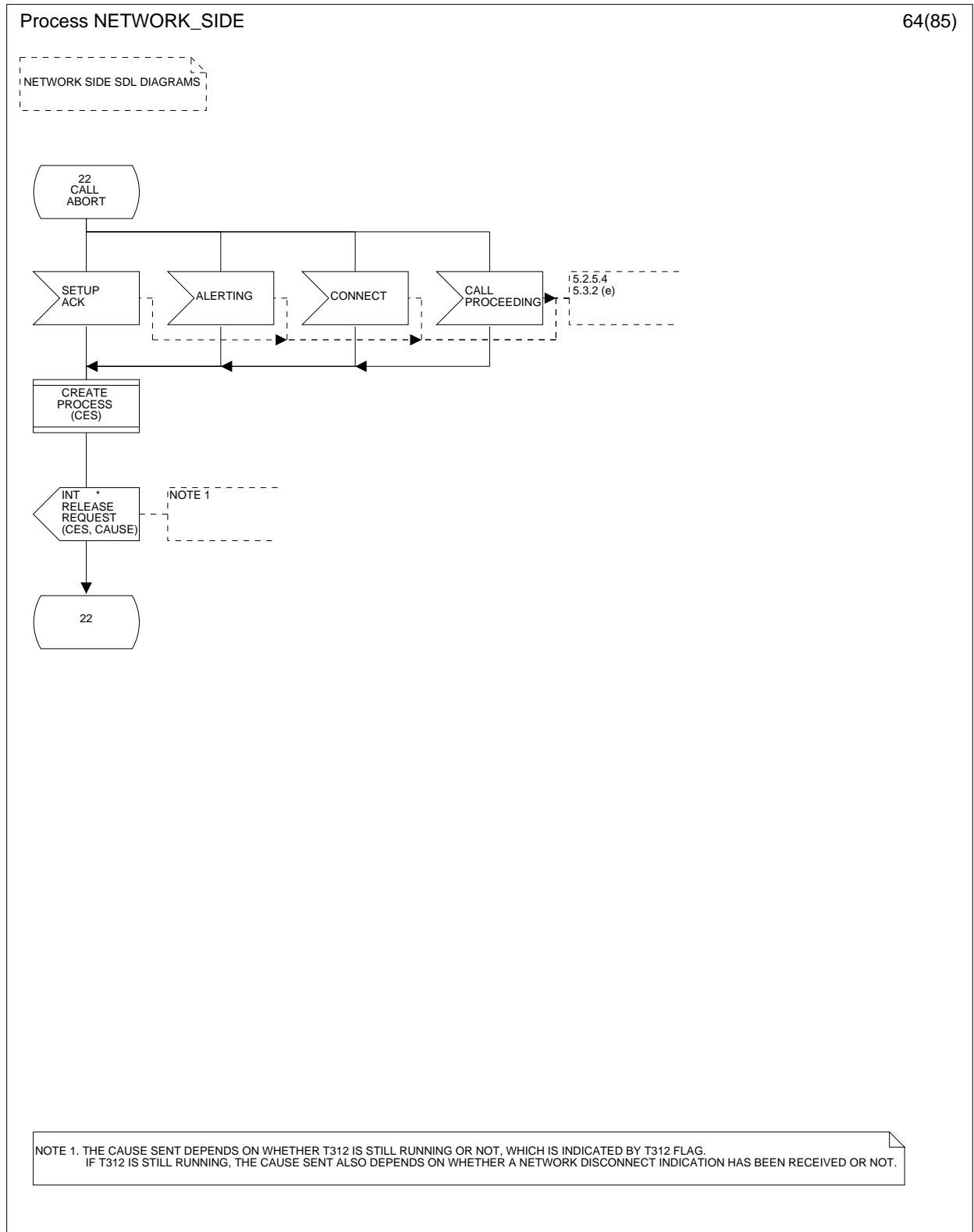

Figure 5 (sheet 64 of 85): Network side SDL diagram



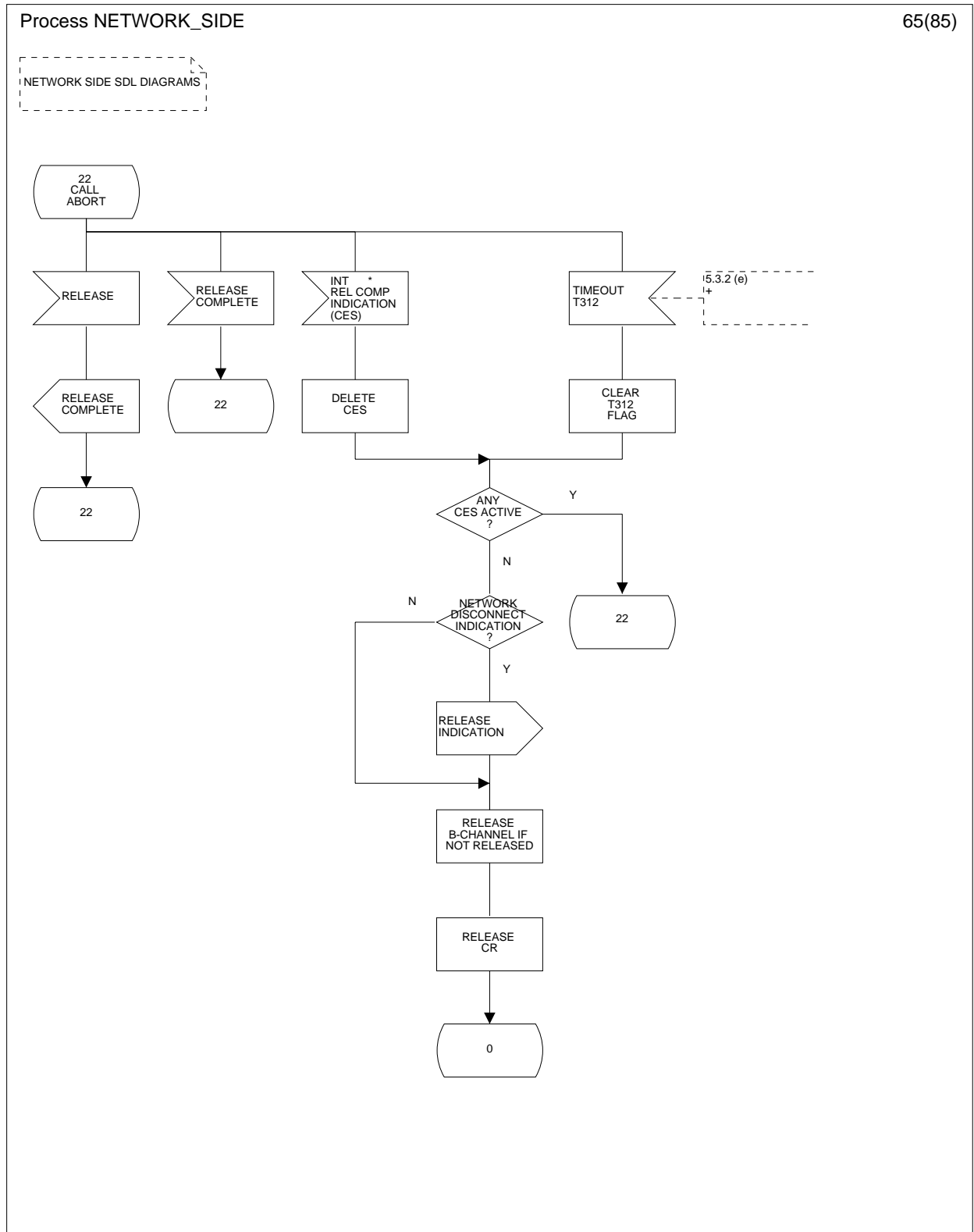

Figure 5 (sheet 65 of 85): Network side SDL diagram

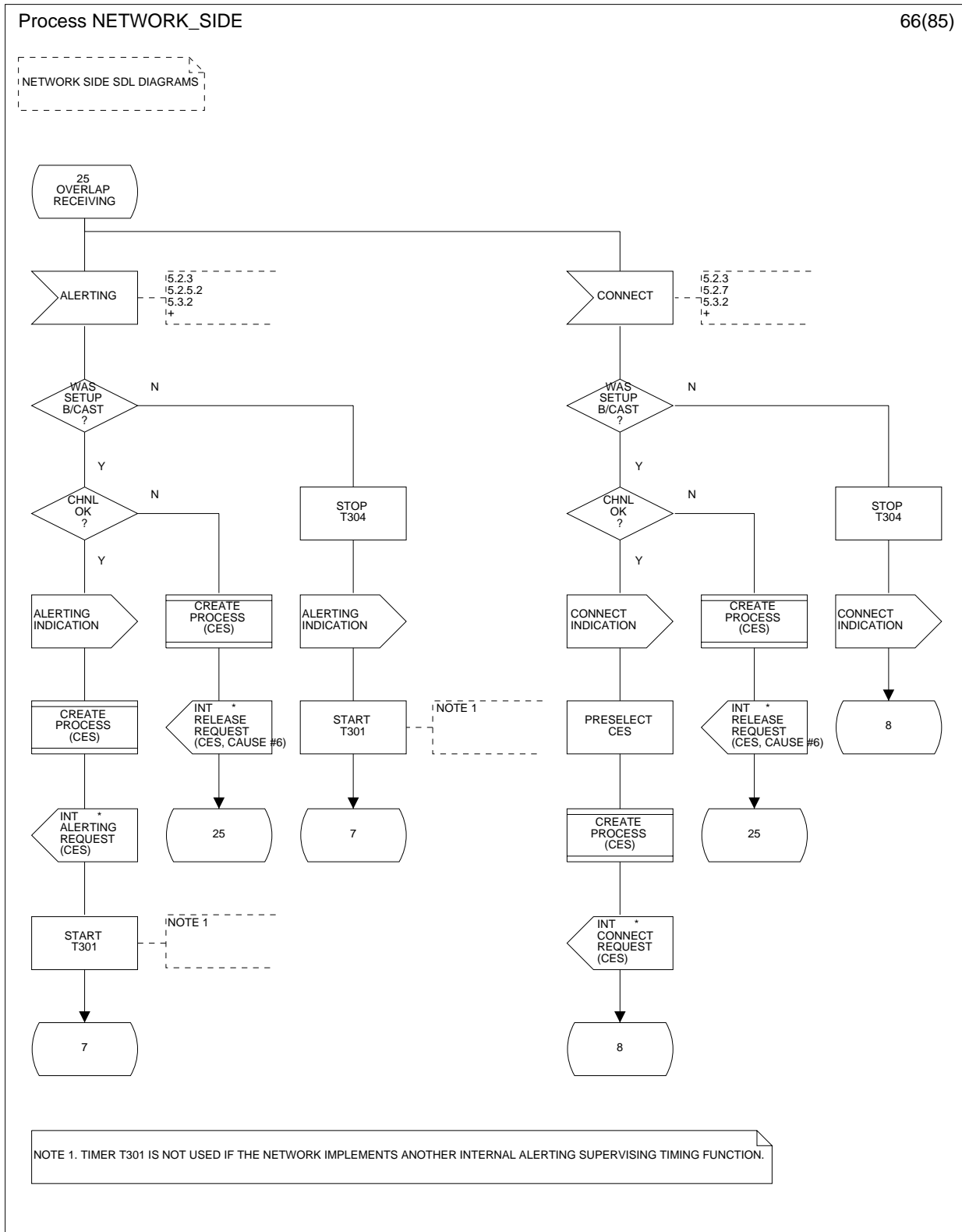

Figure 5 (sheet 66 of 85): Network side SDL diagram

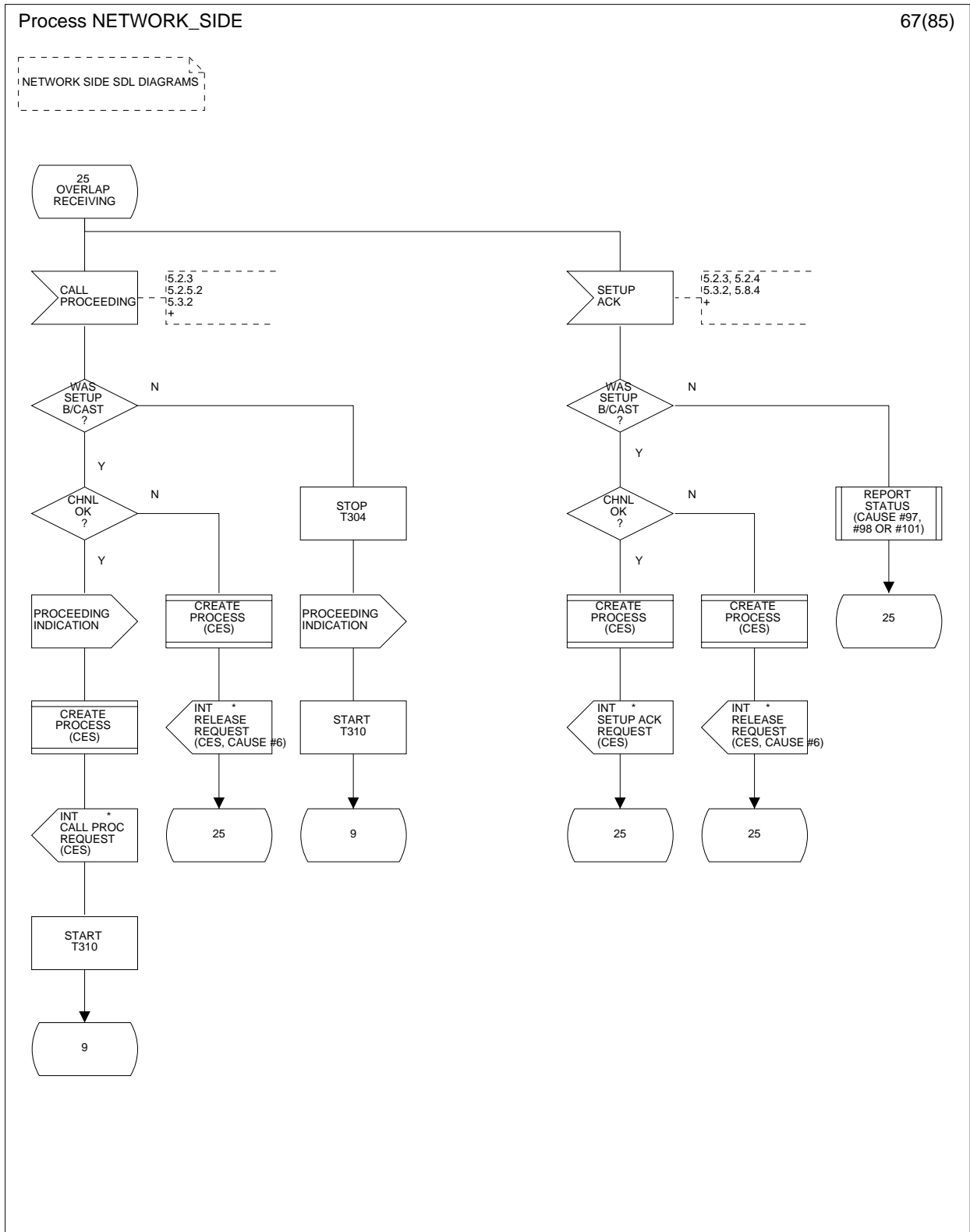

Figure 5 (sheet 67 of 85): Network side SDL diagram

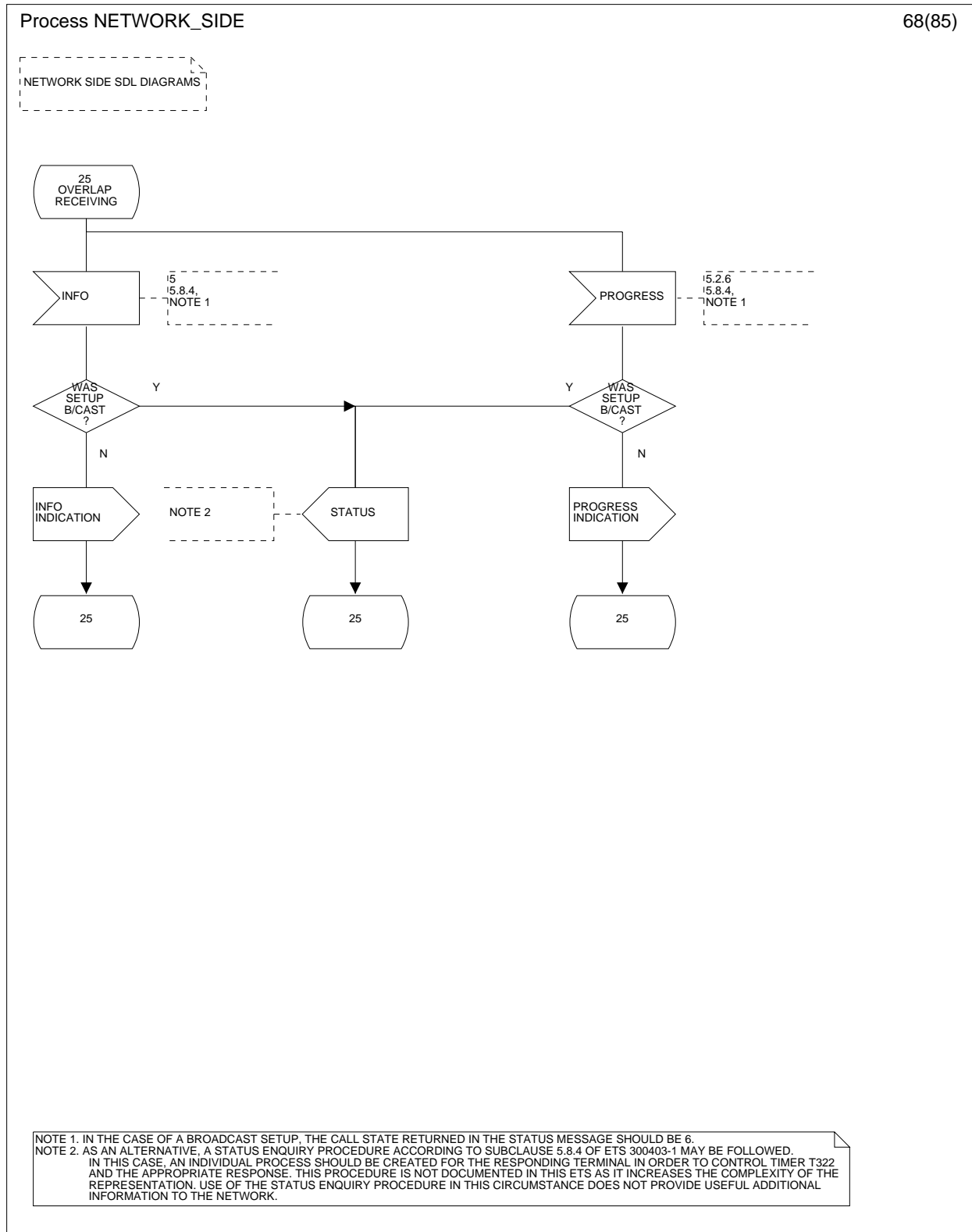
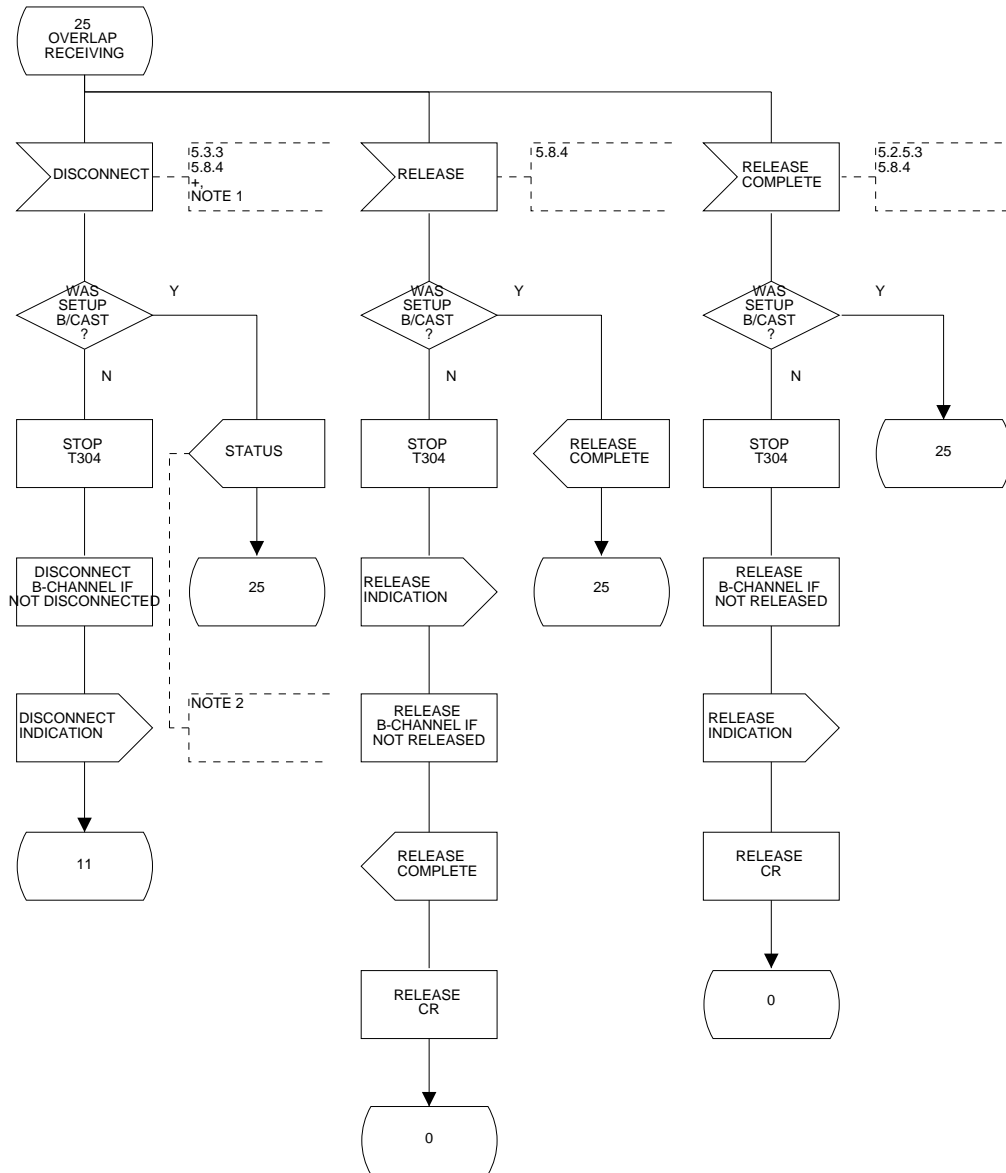

Figure 5 (sheet 68 of 85): Network side SDL diagram

Process NETWORK\_SIDE

69(85)

NETWORK SIDE SDL DIAGRAMS



NOTE 1. IN THE CASE OF A BROADCAST SETUP, THE CALL STATE RETURNED IN THE STATUS MESSAGE SHOULD BE 6.  
 NOTE 2. AS AN ALTERNATIVE, A STATUS ENQUIRY PROCEDURE ACCORDING TO SUBCLAUSE 5.8.4 OF ETS 300403-1 MAY BE FOLLOWED. IN THIS CASE, AN INDIVIDUAL PROCESS SHOULD BE CREATED FOR THE RESPONDING TERMINAL IN ORDER TO CONTROL TIMER T322 AND THE APPROPRIATE RESPONSE. THIS PROCEDURE IS NOT DOCUMENTED IN THIS ETS AS IT INCREASES THE COMPLEXITY OF THE REPRESENTATION. USE OF THE STATUS ENQUIRY PROCEDURE IN THIS CIRCUMSTANCE DOES NOT PROVIDE USEFUL ADDITIONAL INFORMATION TO THE NETWORK.

Figure 5 (sheet 69 of 85): Network side SDL diagram

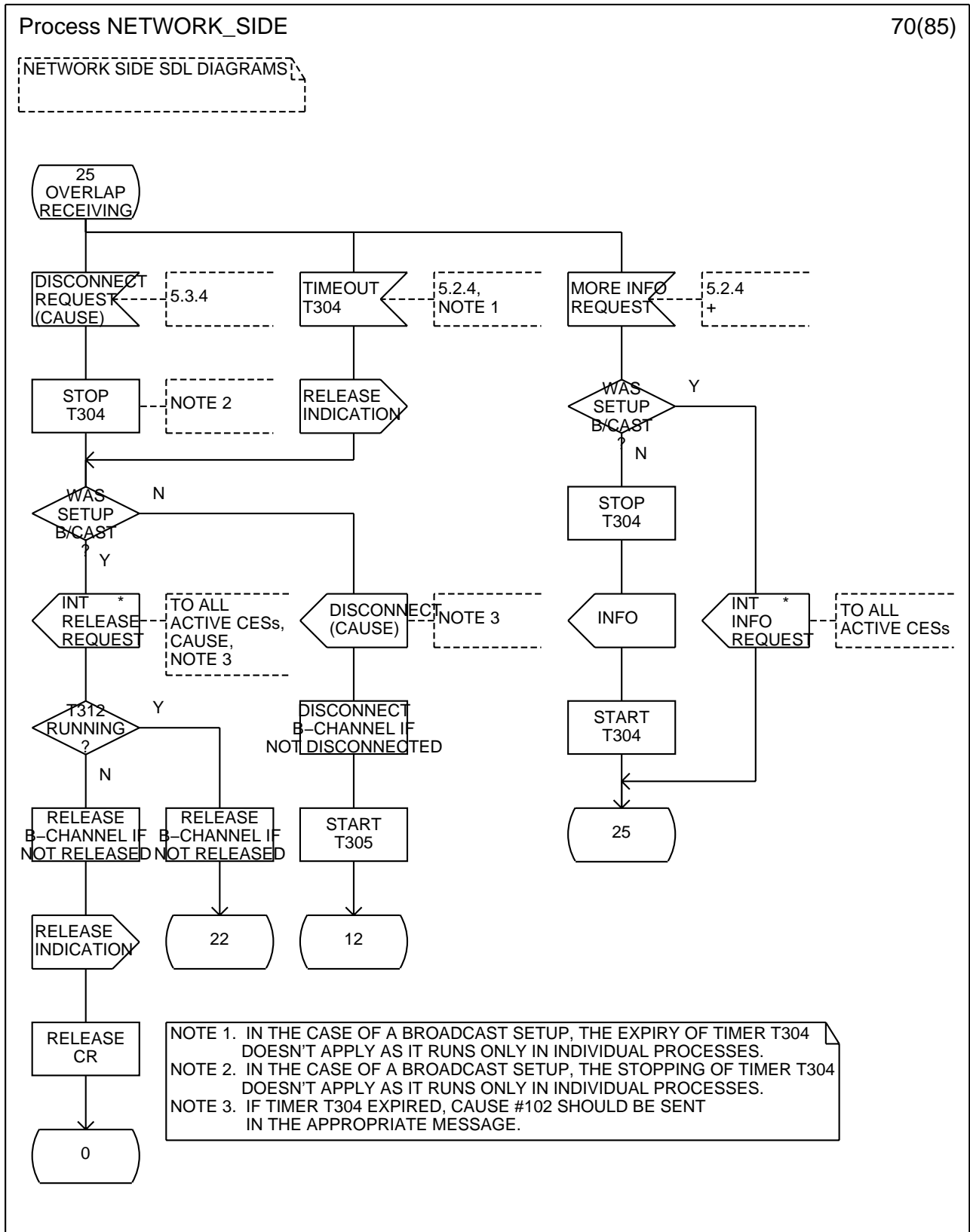

Figure 5 (sheet 70 of 85): Network side SDL diagram

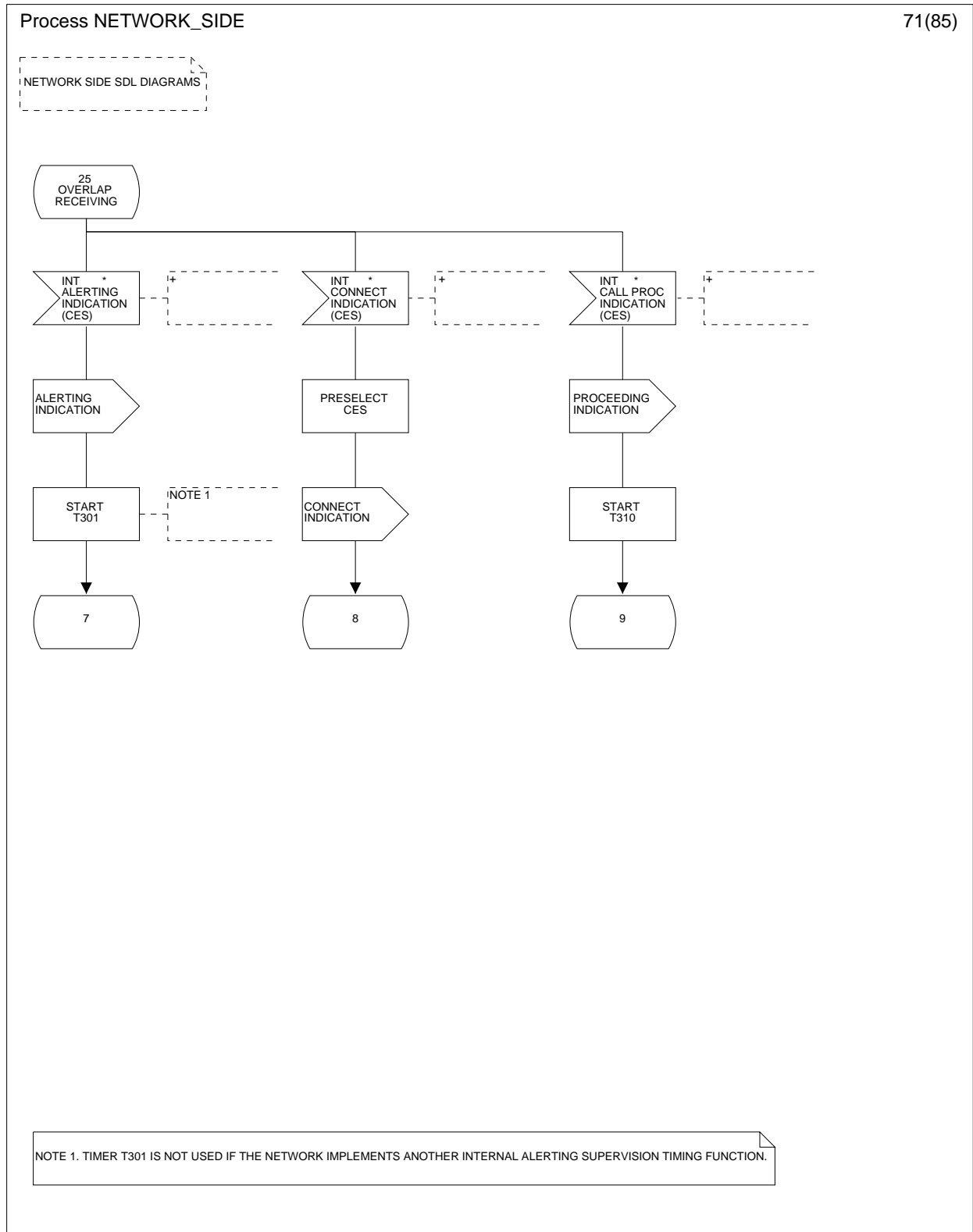

Figure 5 (sheet 71 of 85): Network side SDL diagram

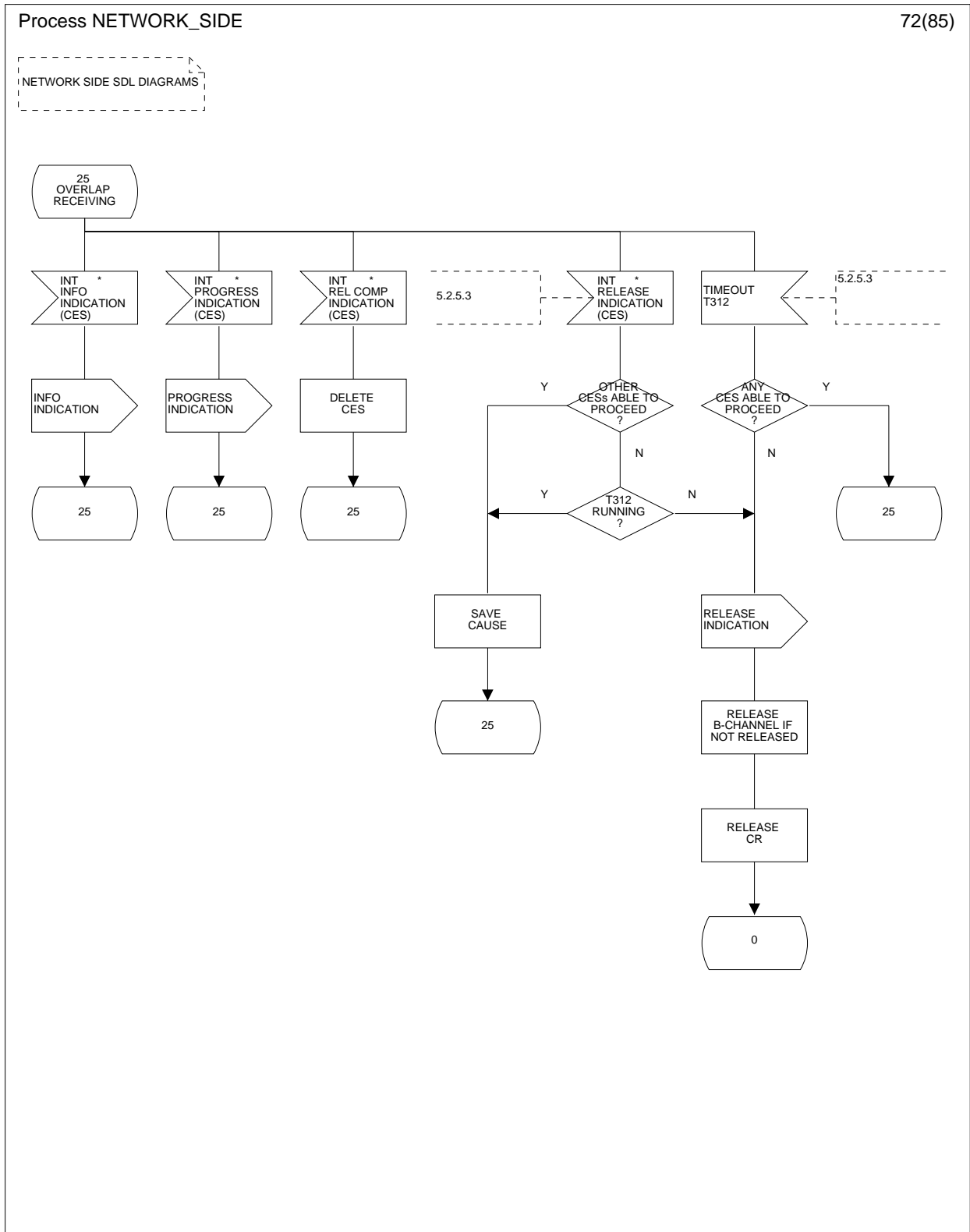

Figure 5 (sheet 72 of 85): Network side SDL diagram



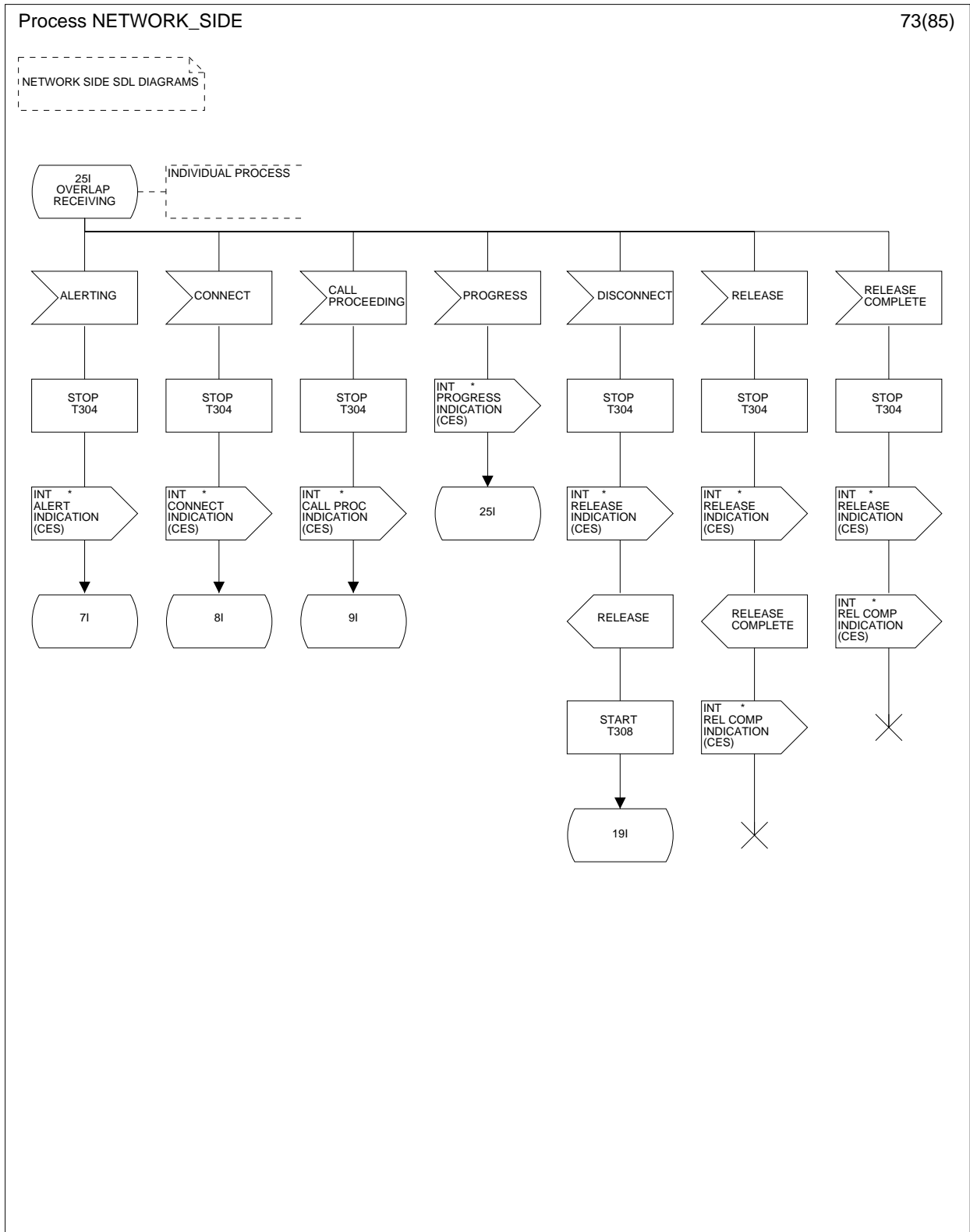

Figure 5 (sheet 73 of 85): Network side SDL diagram

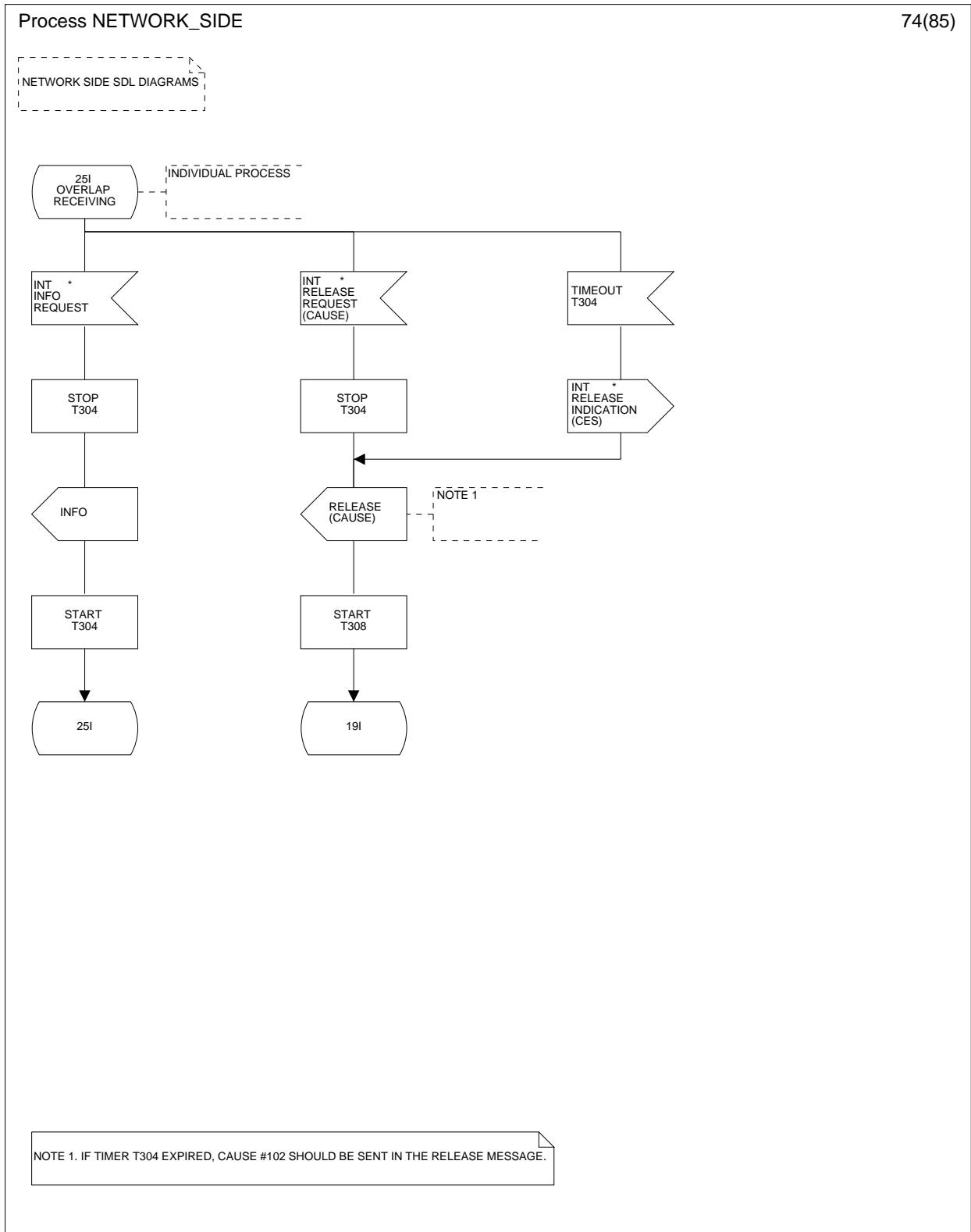

Figure 5 (sheet 74 of 85): Network side SDL diagram

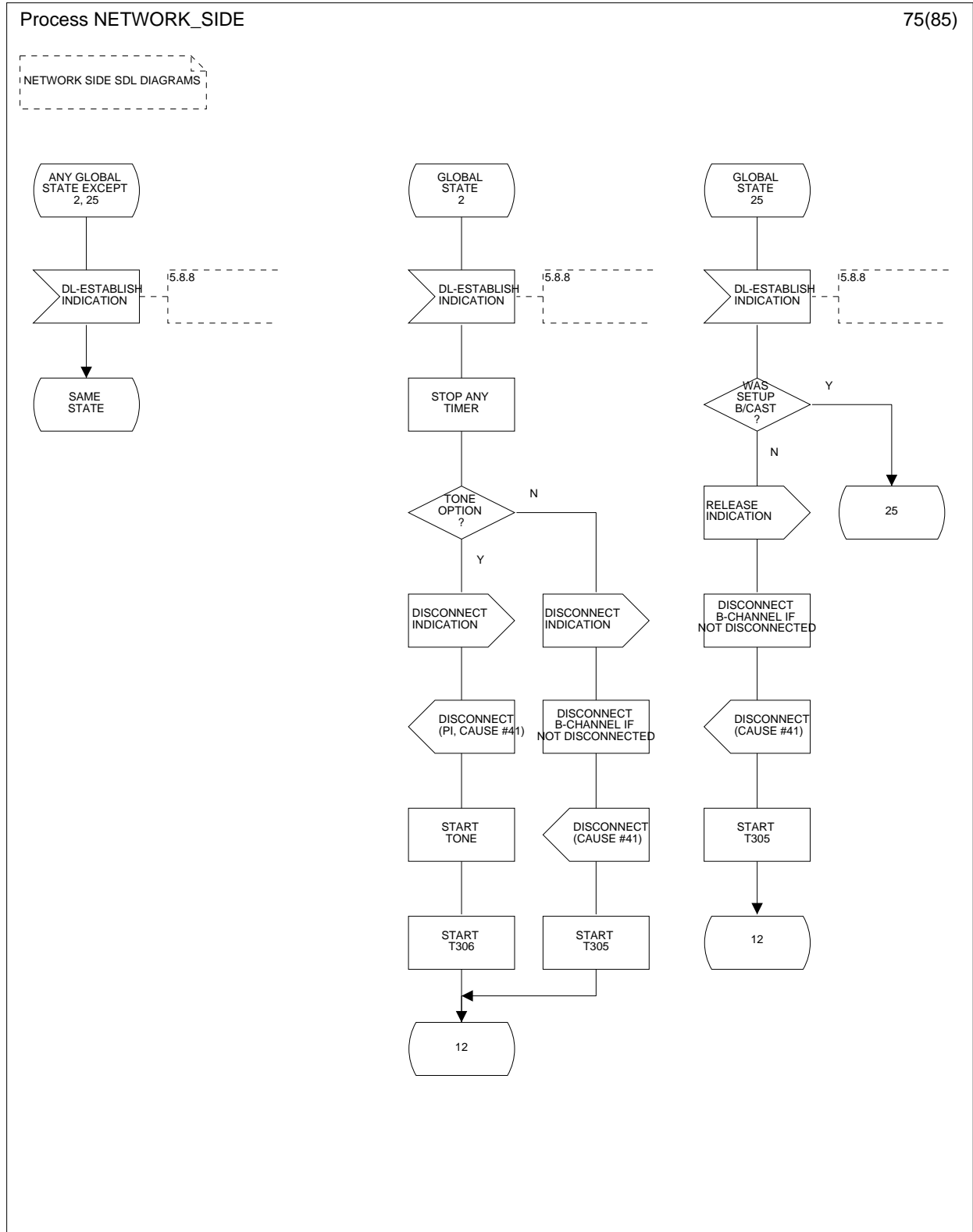

Figure 5 (sheet 75 of 85): Network side SDL diagram

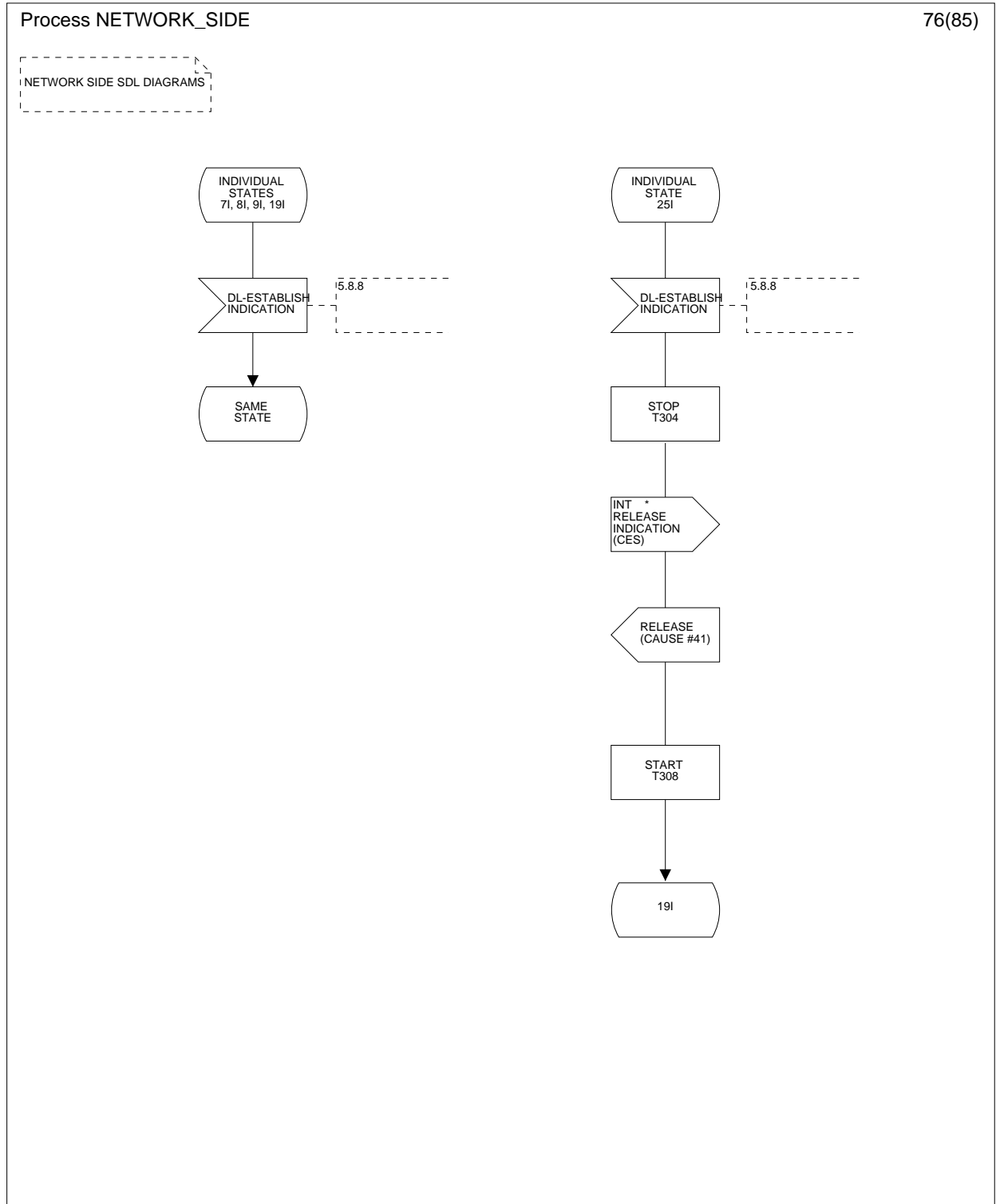

Figure 5 (sheet 76 of 85): Network side SDL diagram

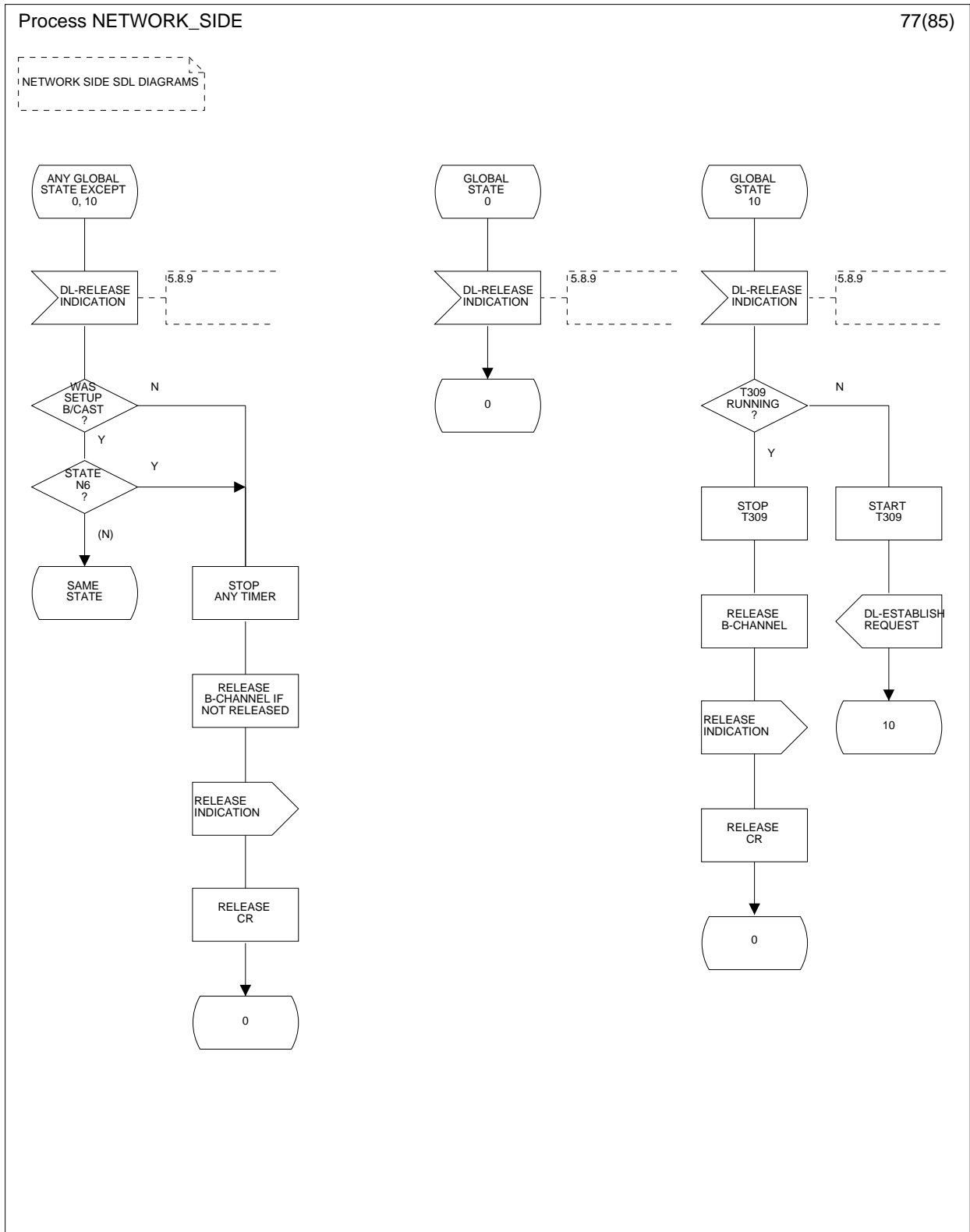

Figure 5 (sheet 77 of 85): Network side SDL diagram

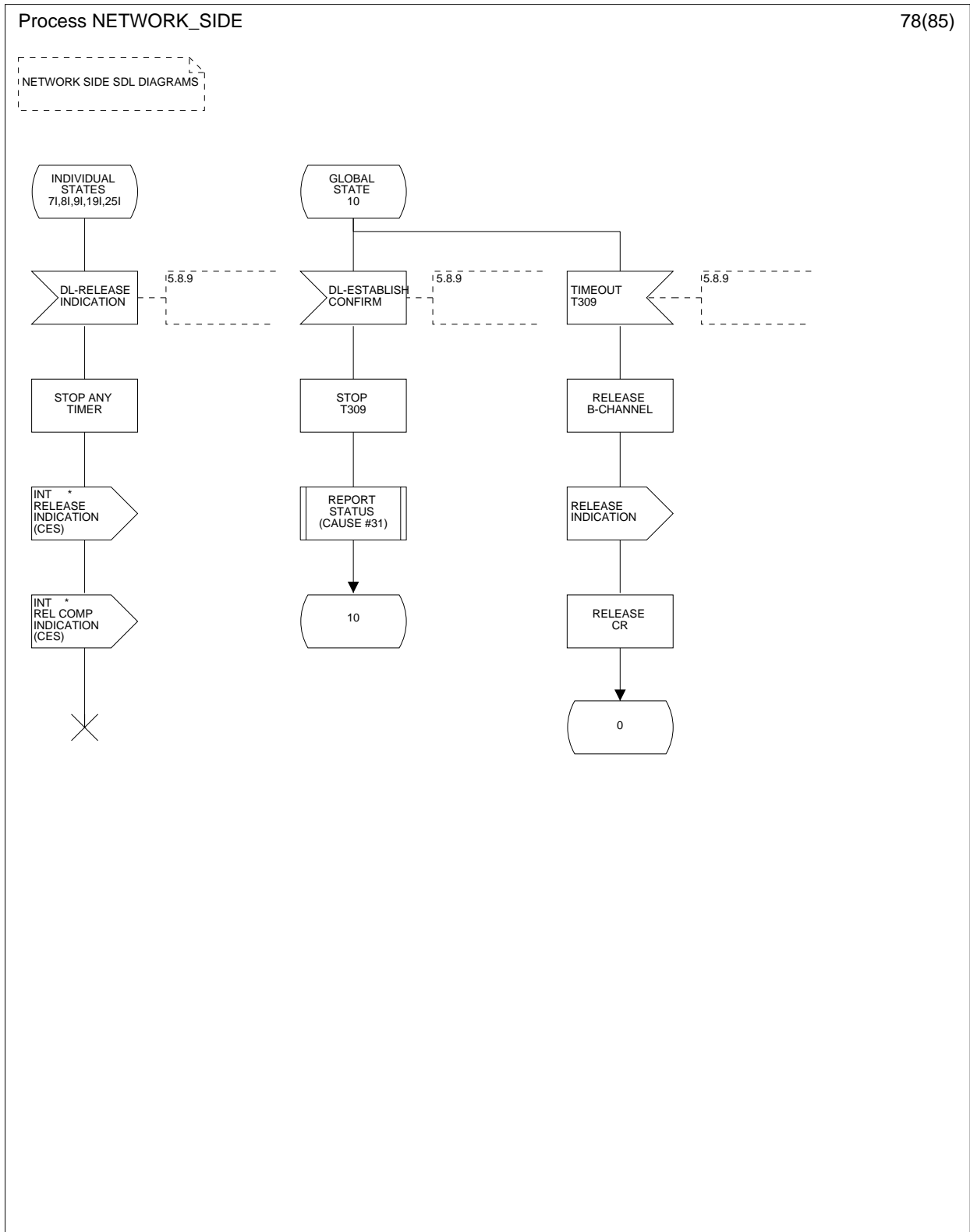

Figure 5 (sheet 78 of 85): Network side SDL diagram

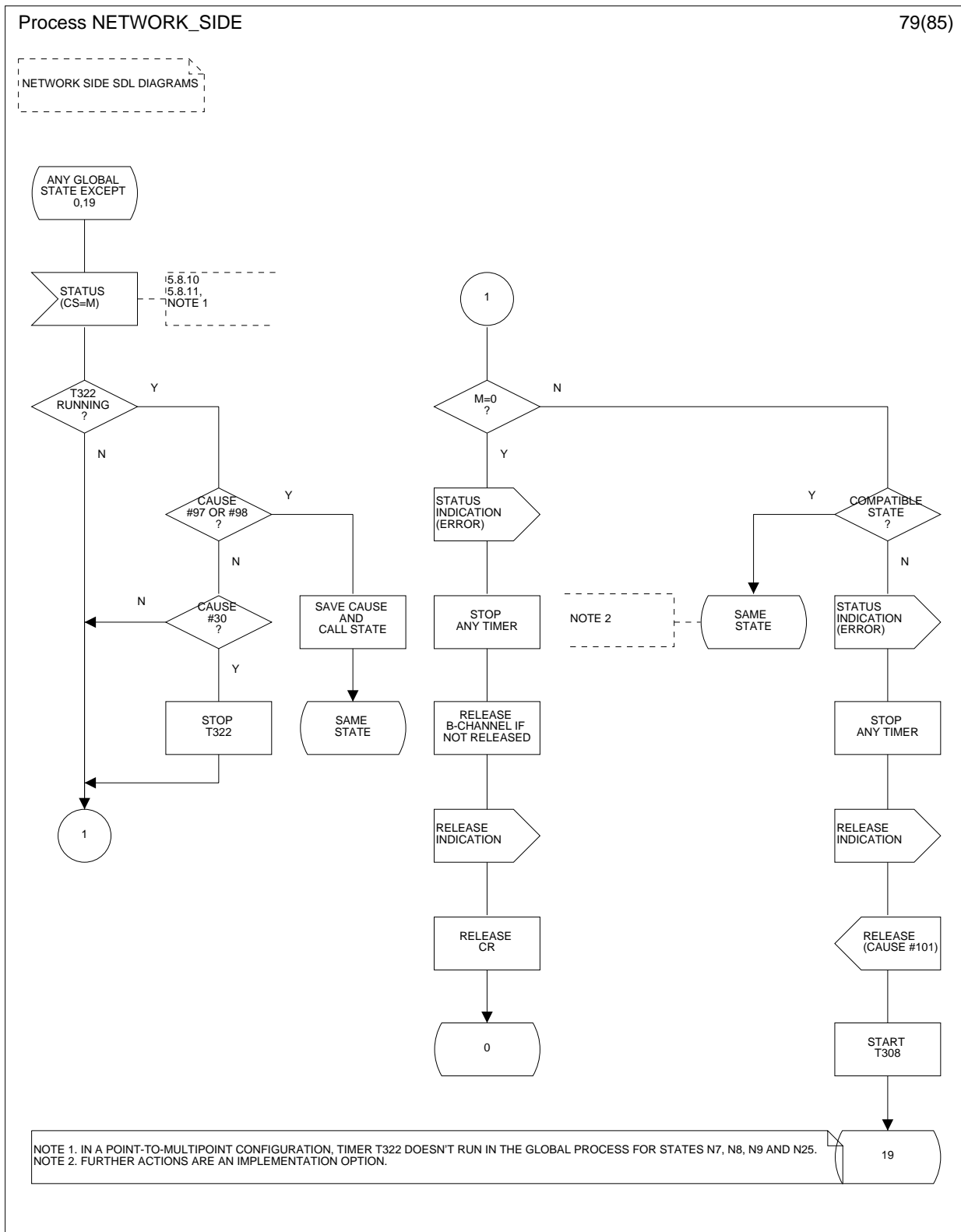

Figure 5 (sheet 79 of 85): Network side SDL diagram

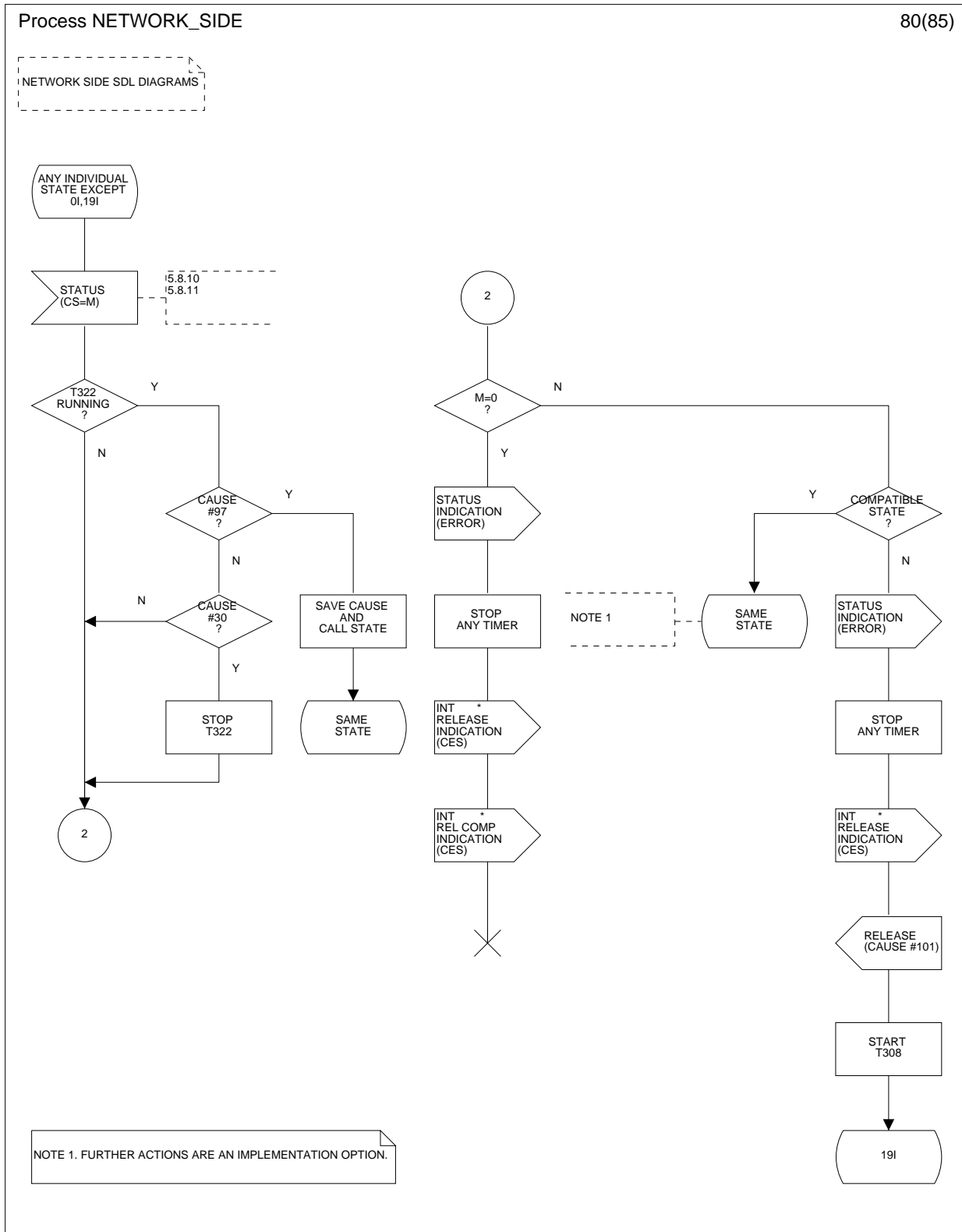

Figure 5 (sheet 80 of 85): Network side SDL diagram



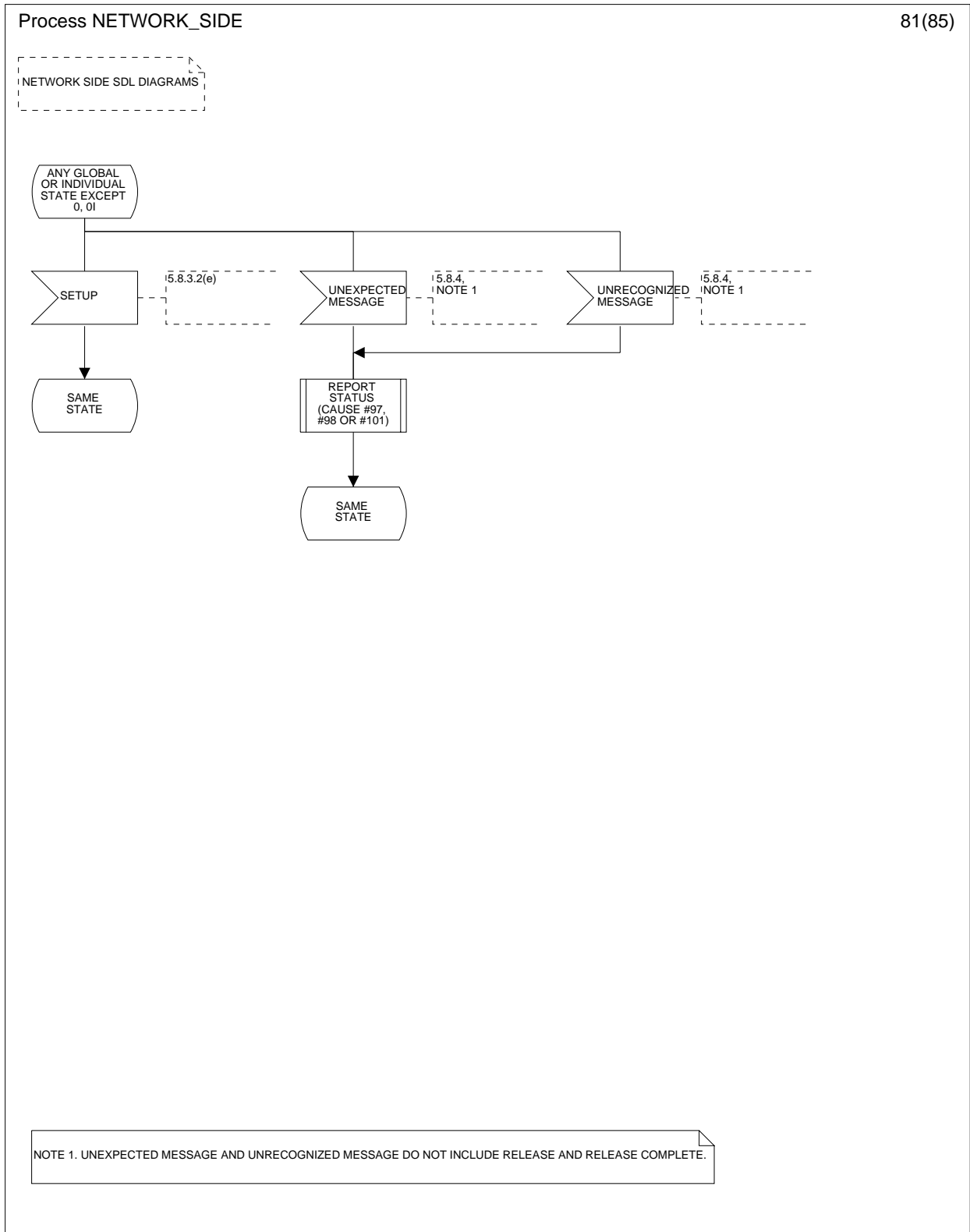

Figure 5 (sheet 81 of 85): Network side SDL diagram

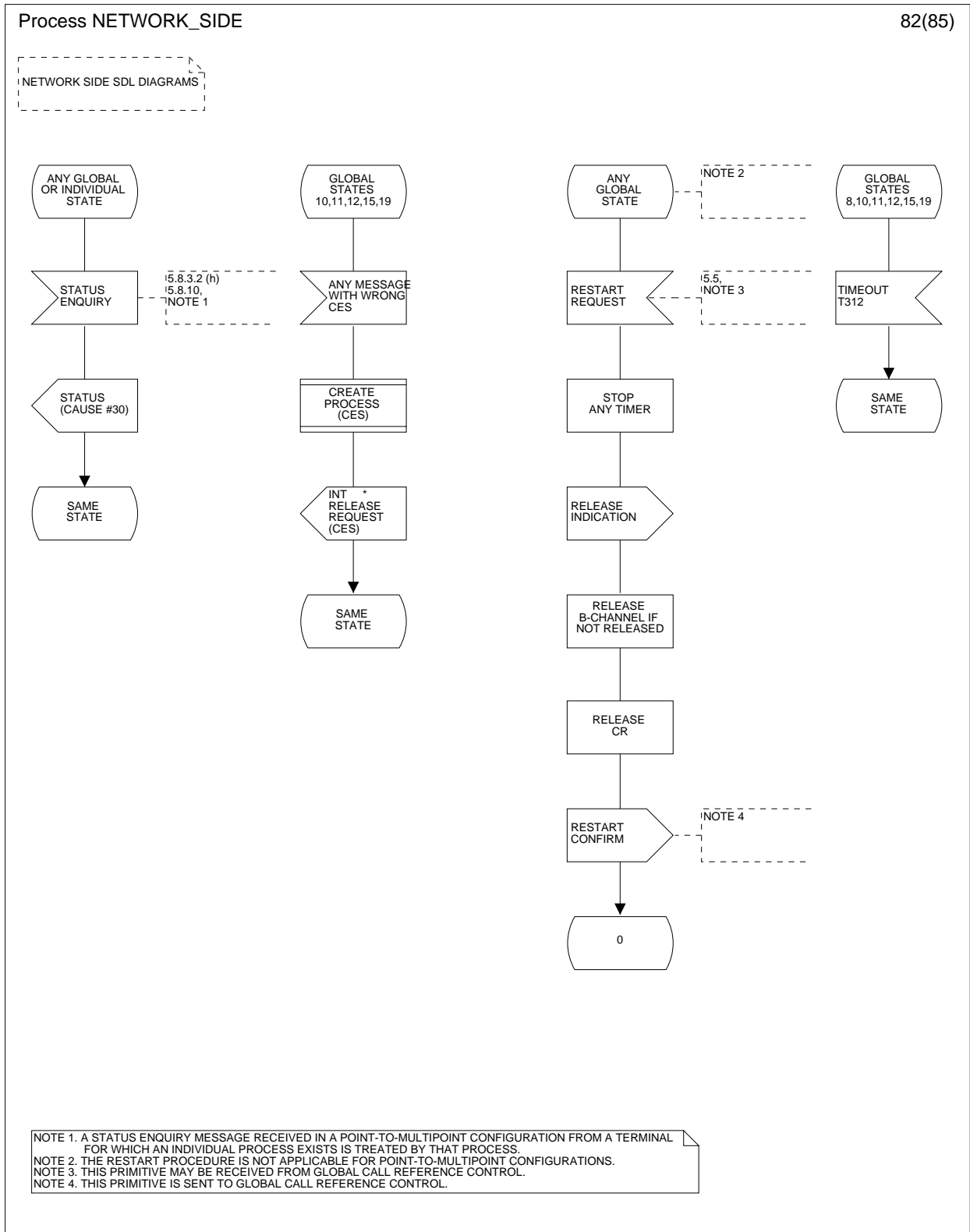

Figure 5 (sheet 82 of 85): Network side SDL diagram

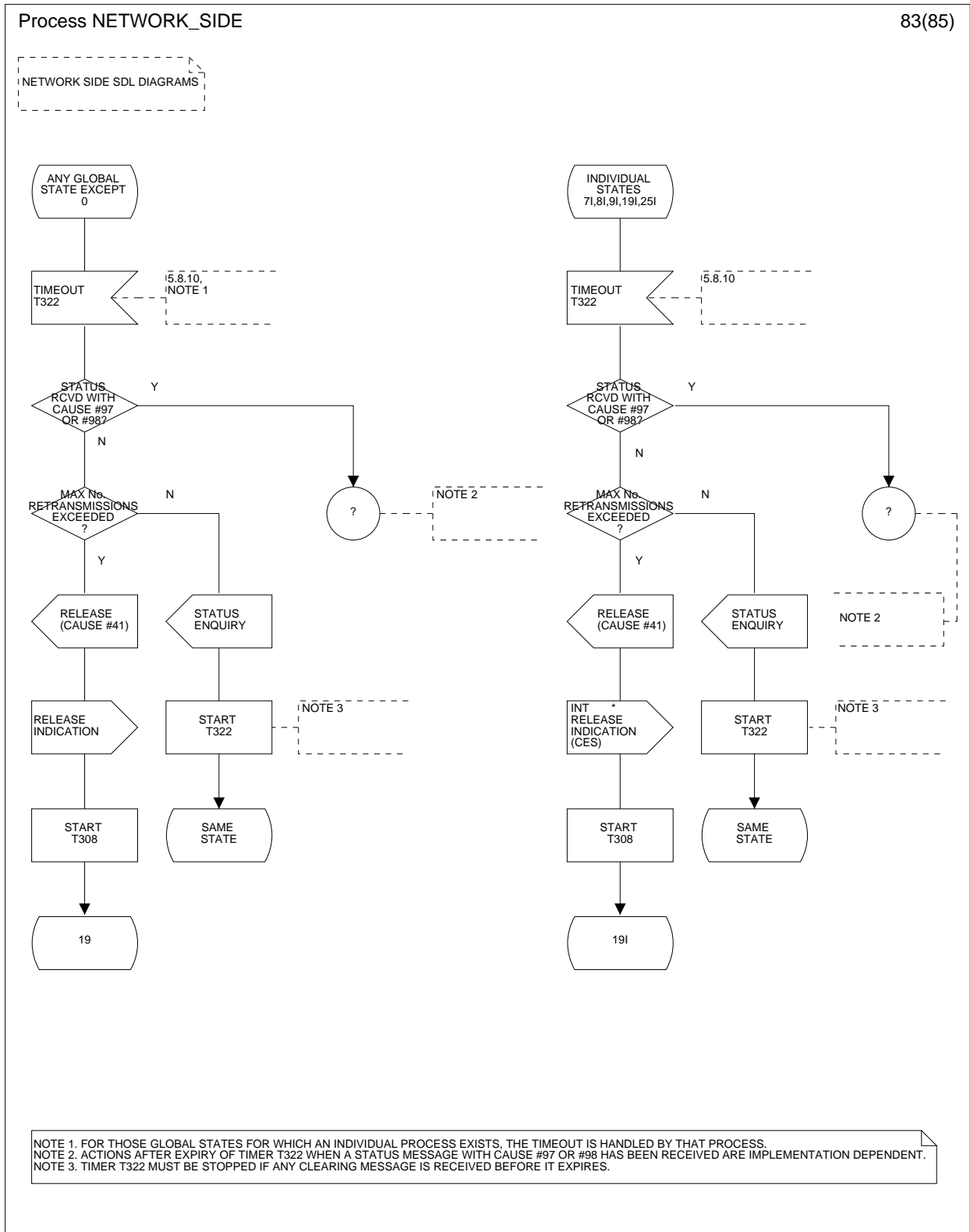

Figure 5 (sheet 83 of 85): Network side SDL diagram

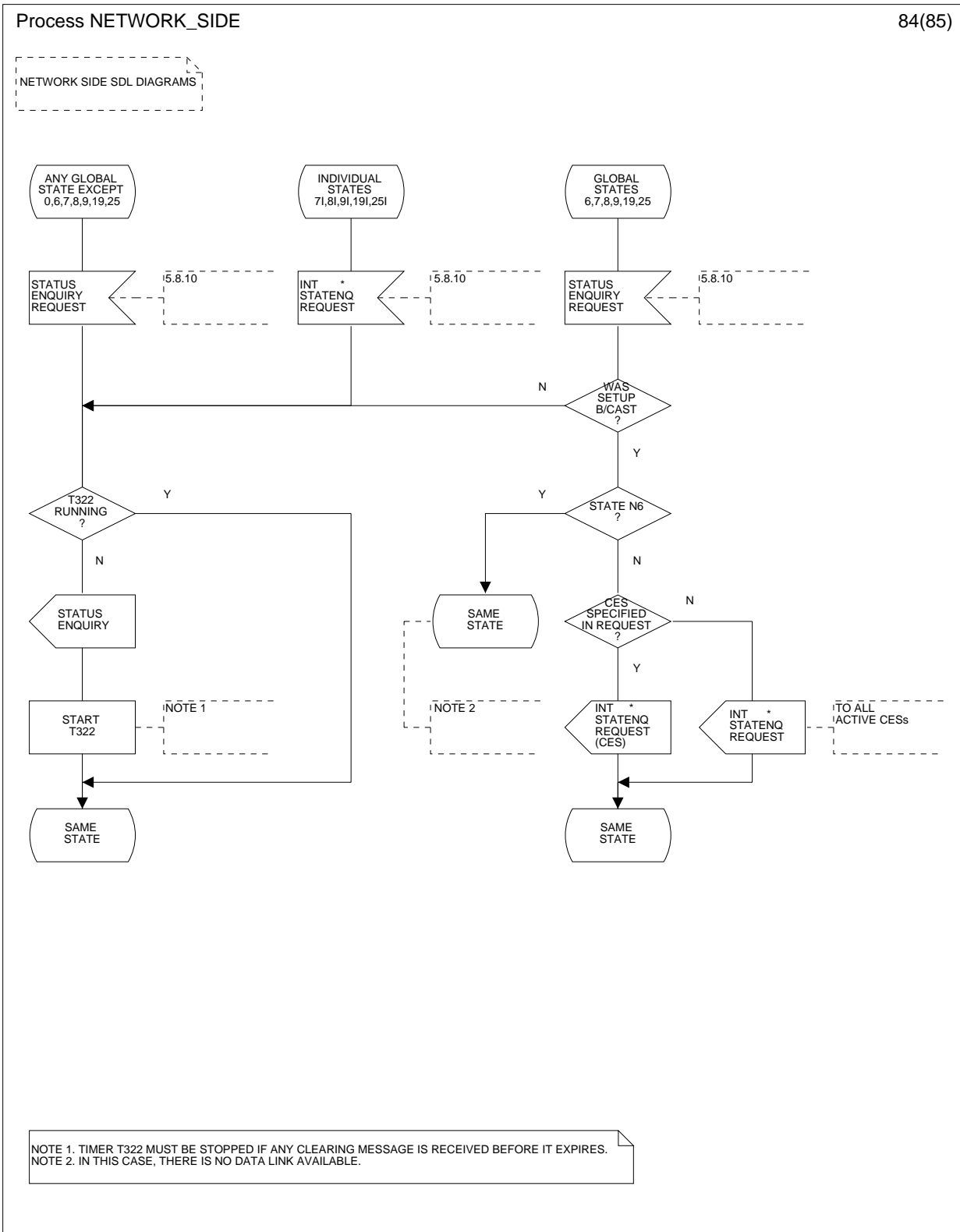
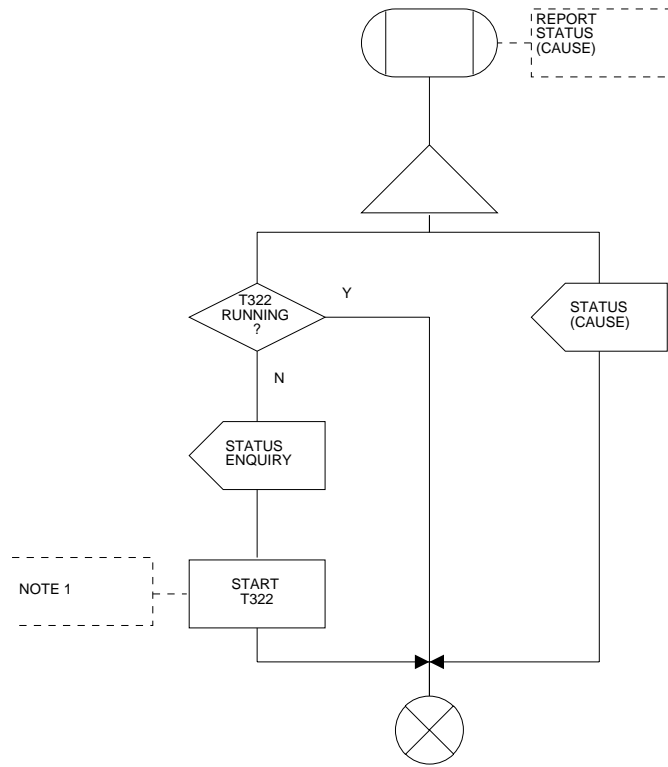

Figure 5 (sheet 84 of 85): Network side SDL diagram

Process NETWORK\_SIDE

85(85)

NETWORK SIDE SDL DIAGRAMS



NOTE 1. TIMER T322 MUST BE STOPPED IF ANY CLEARING MESSAGE IS RECEIVED BEFORE IT EXPIRES.

Figure 5 (sheet 85 of 85): Network side SDL diagram



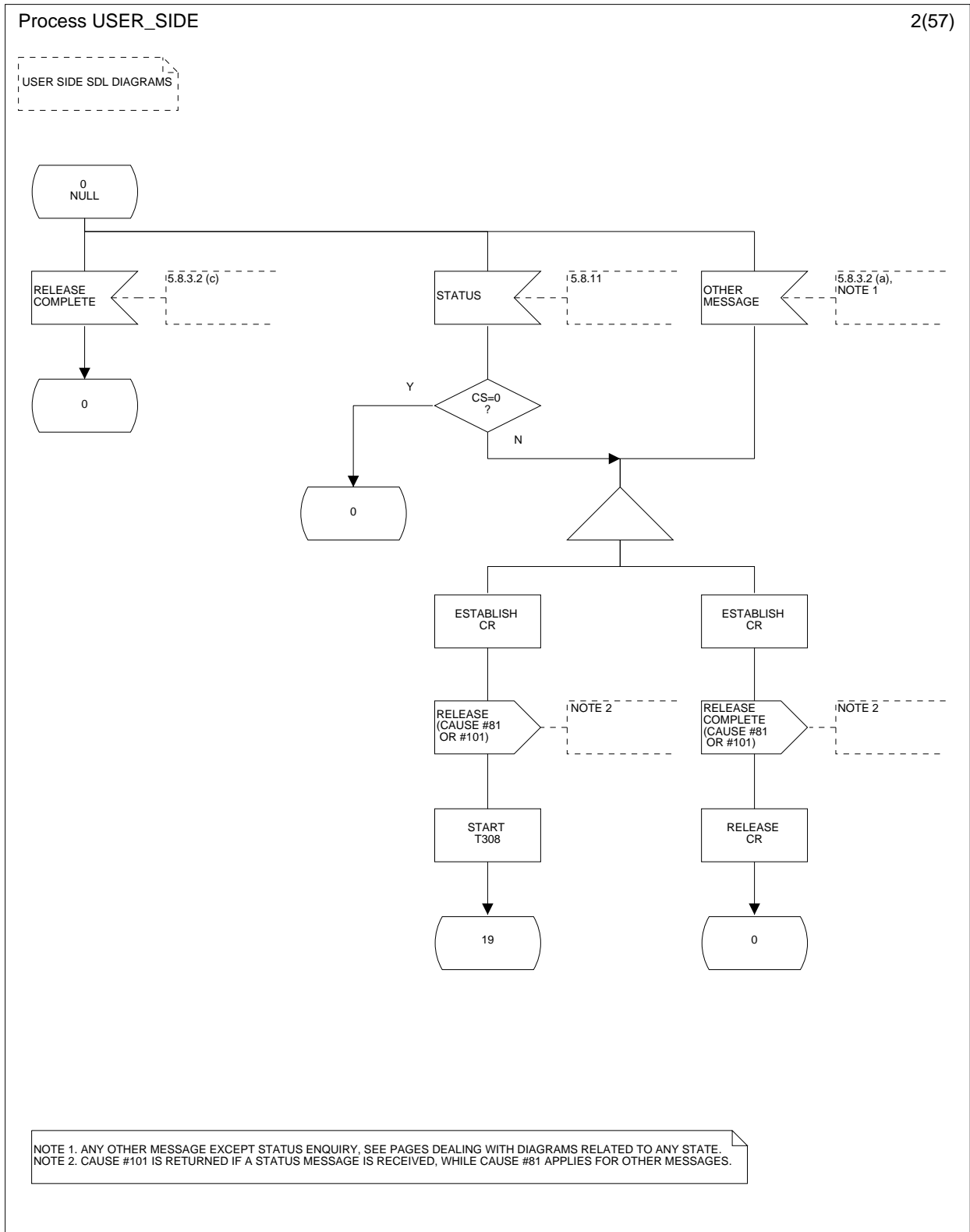

Figure 6 (sheet 2 of 57): User side SDL diagram

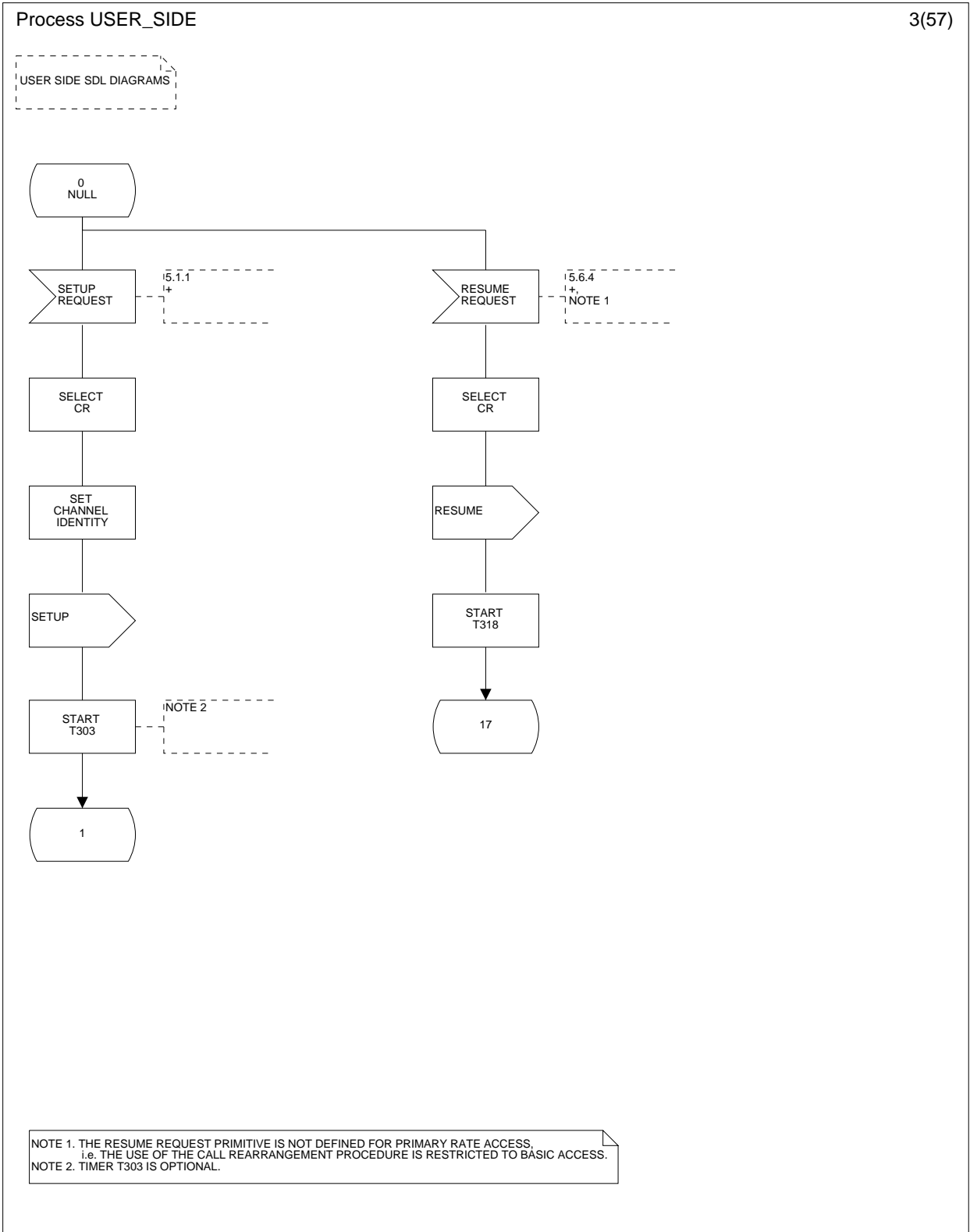

Figure 6 (sheet 3 of 57): User side SDL diagram



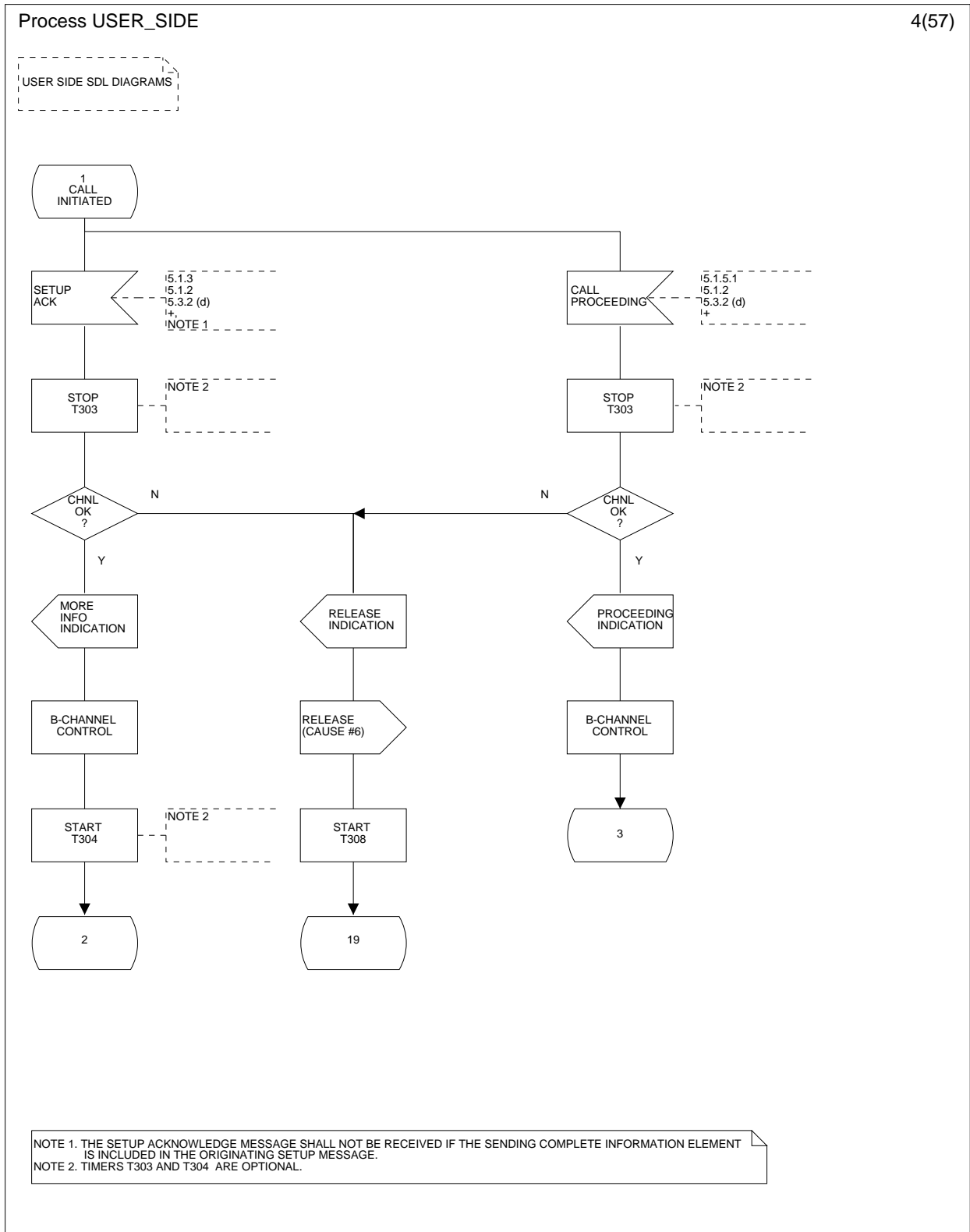

Figure 6 (sheet 4 of 57): User side SDL diagram

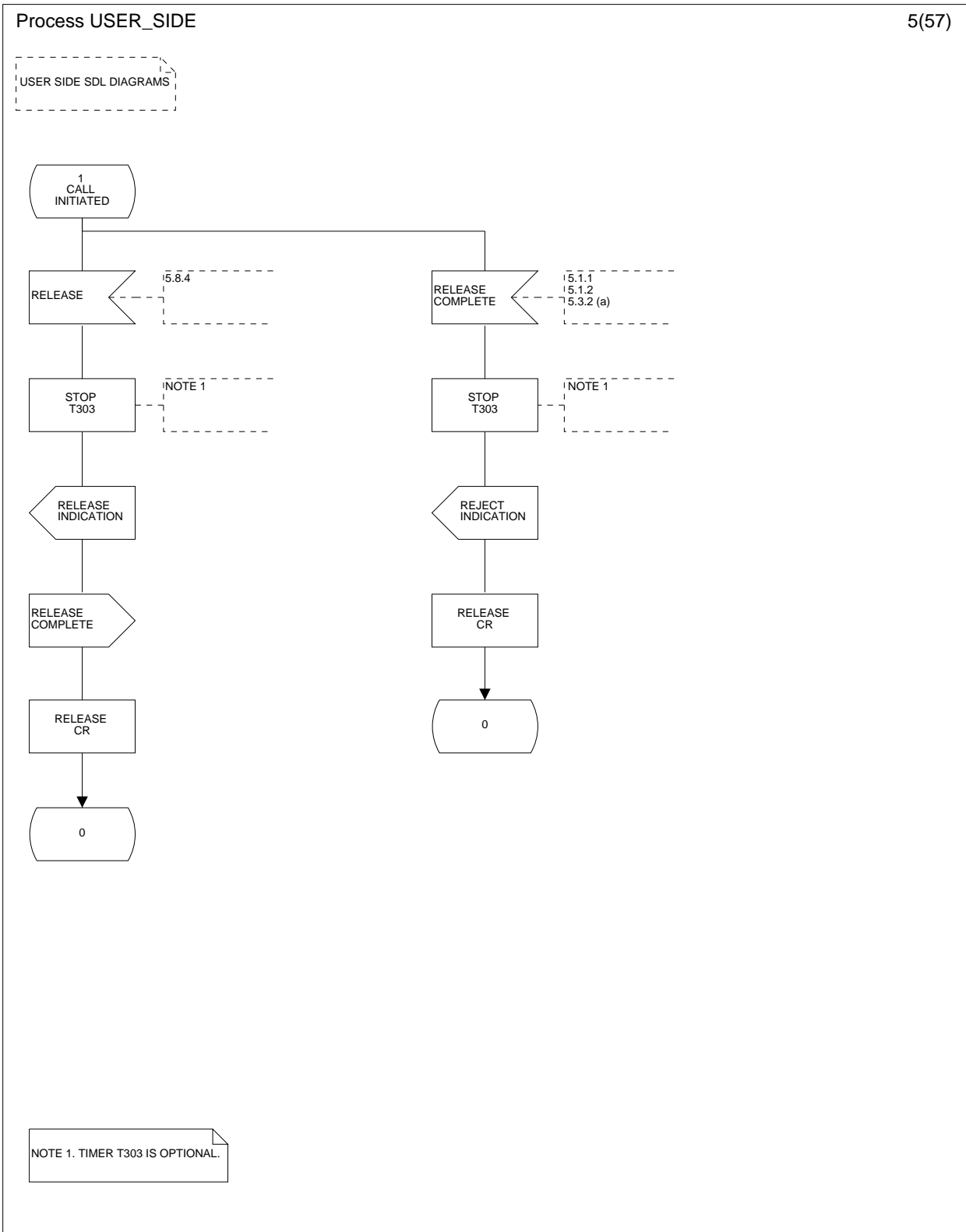
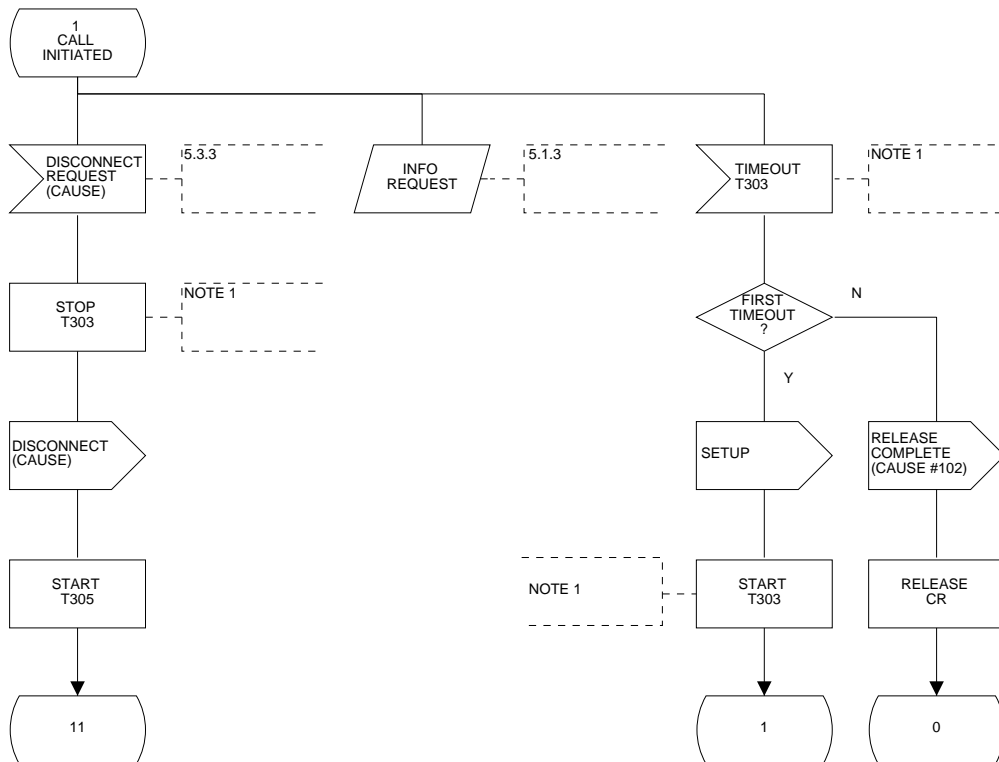

Figure 6 (sheet 5 of 57): User side SDL diagram

Process USER\_SIDE

6(57)

USER SIDE SDL DIAGRAMS



NOTE 1. TIMER T303 IS OPTIONAL.

Figure 6 (sheet 6 of 57): User side SDL diagram

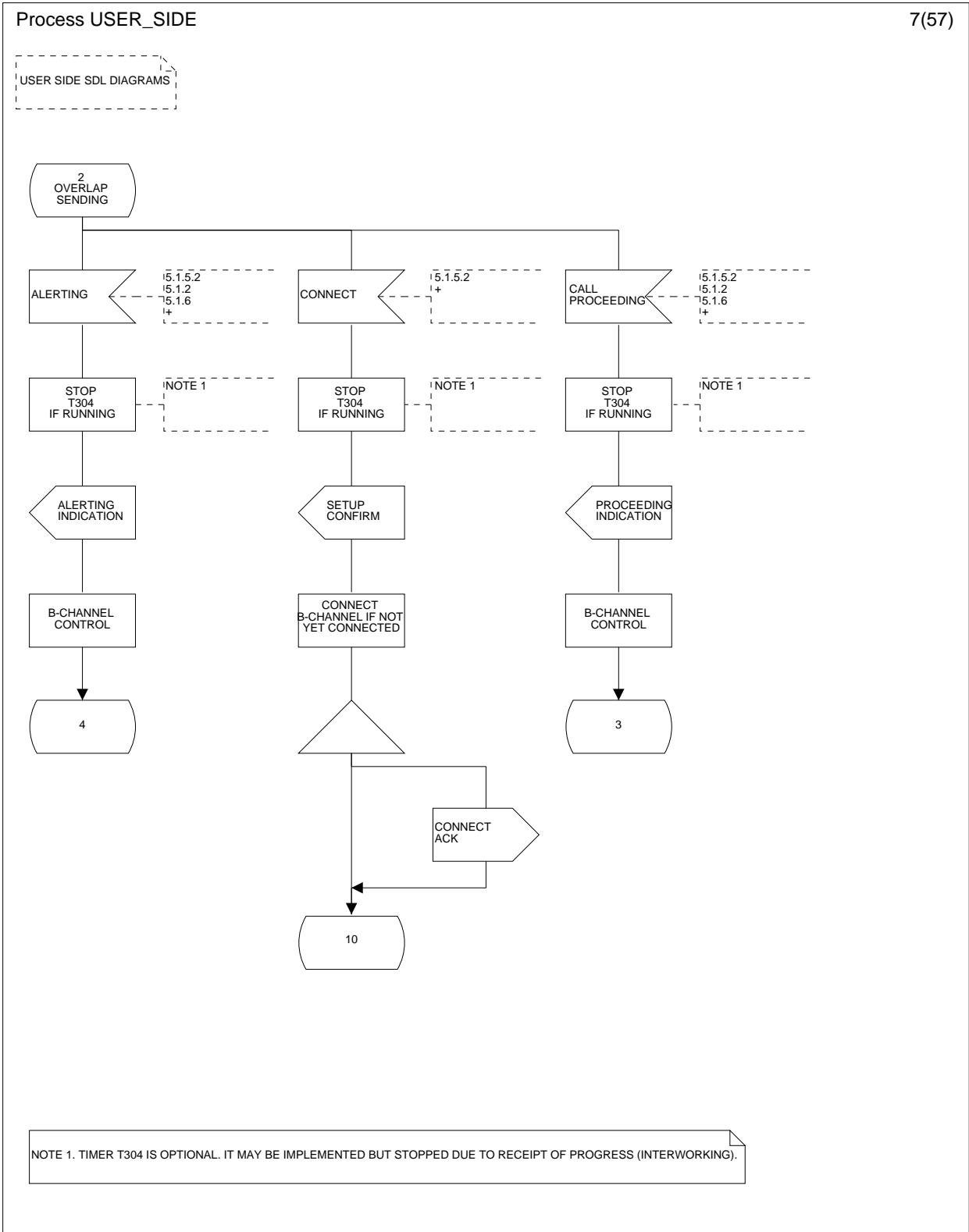

Figure 6 (sheet 7 of 57): User side SDL diagram

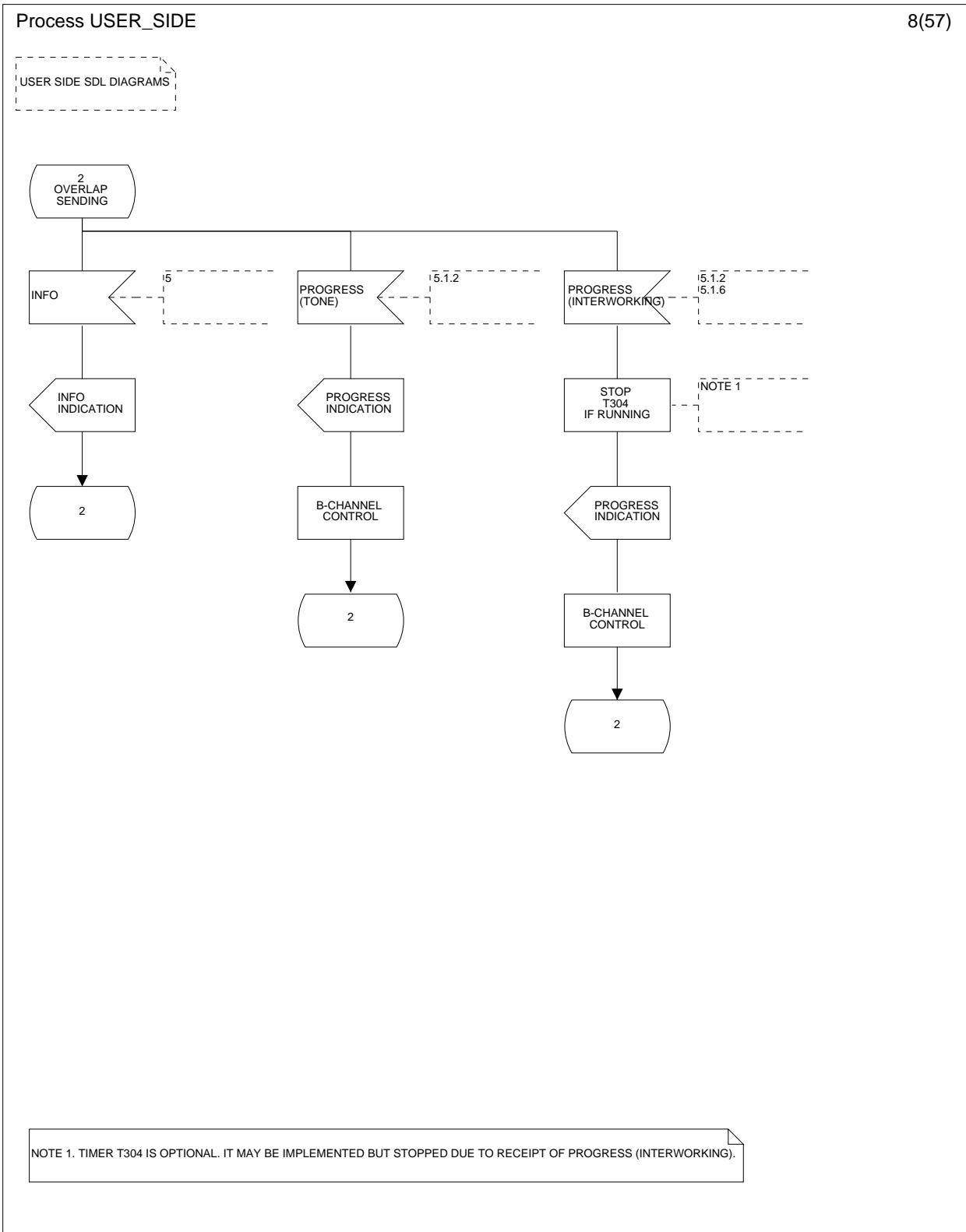

Figure 6 (sheet 8 of 57): User side SDL diagram

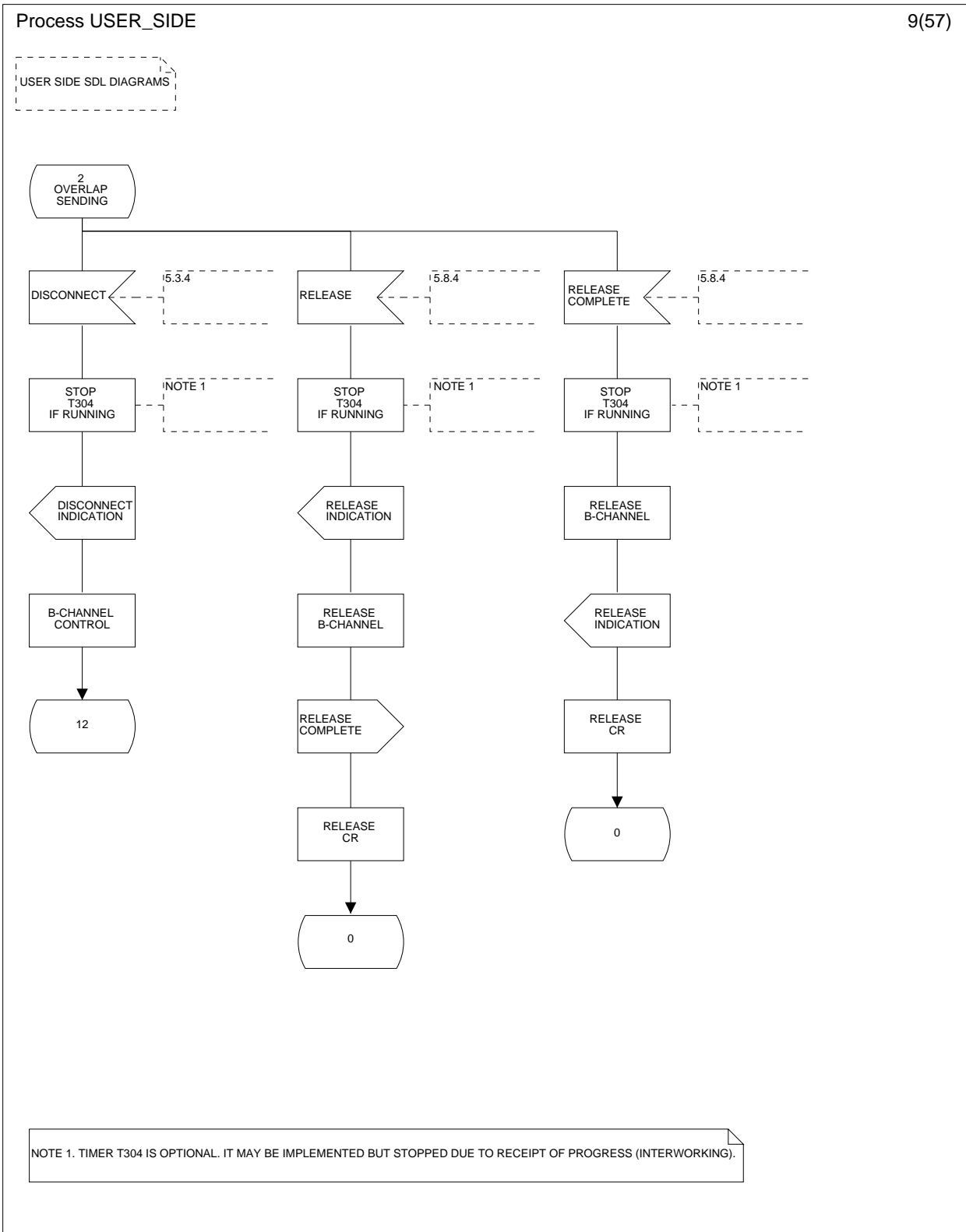

Figure 6 (sheet 9 of 57): User side SDL diagram

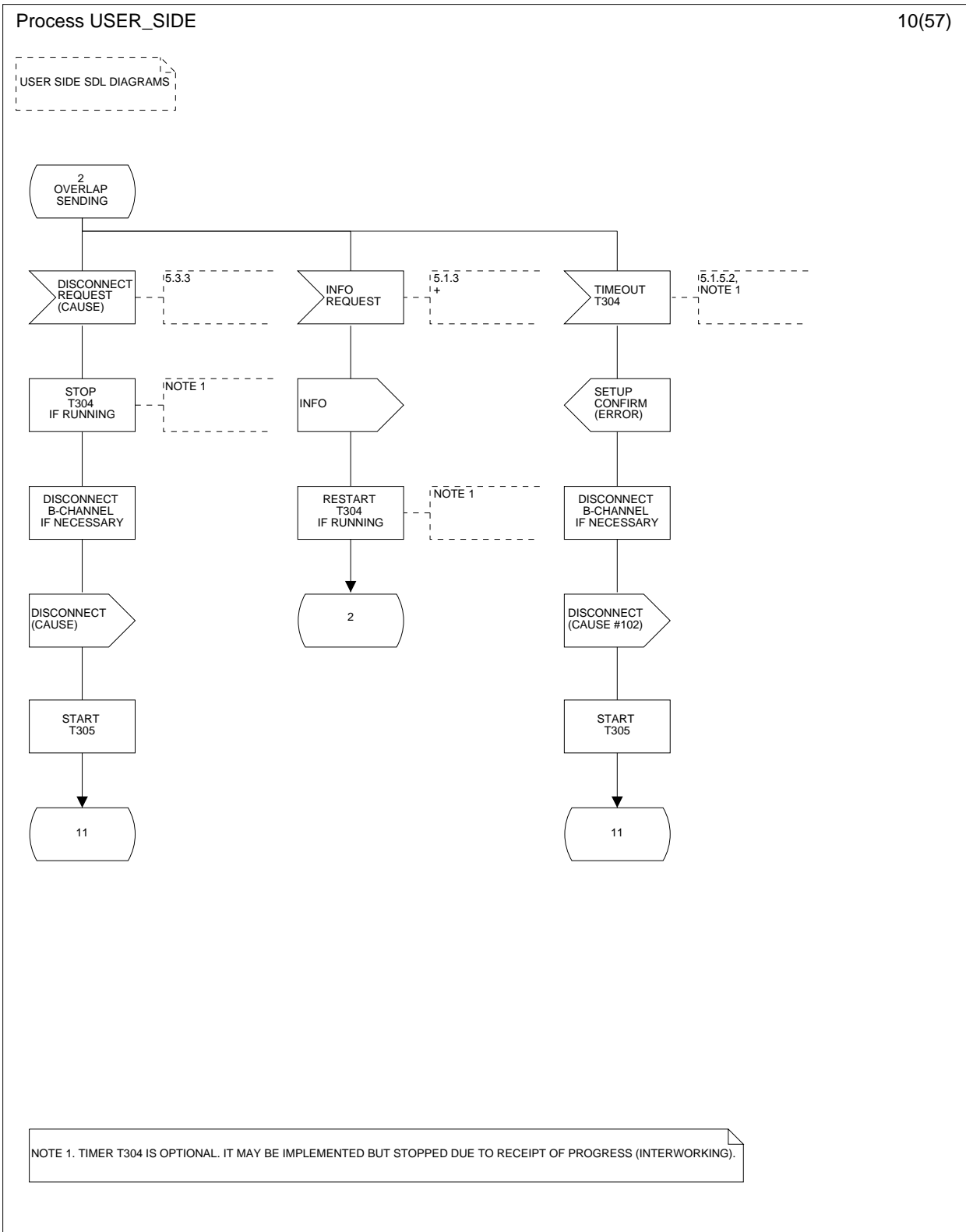

Figure 6 (sheet 10 of 57): User side SDL diagram

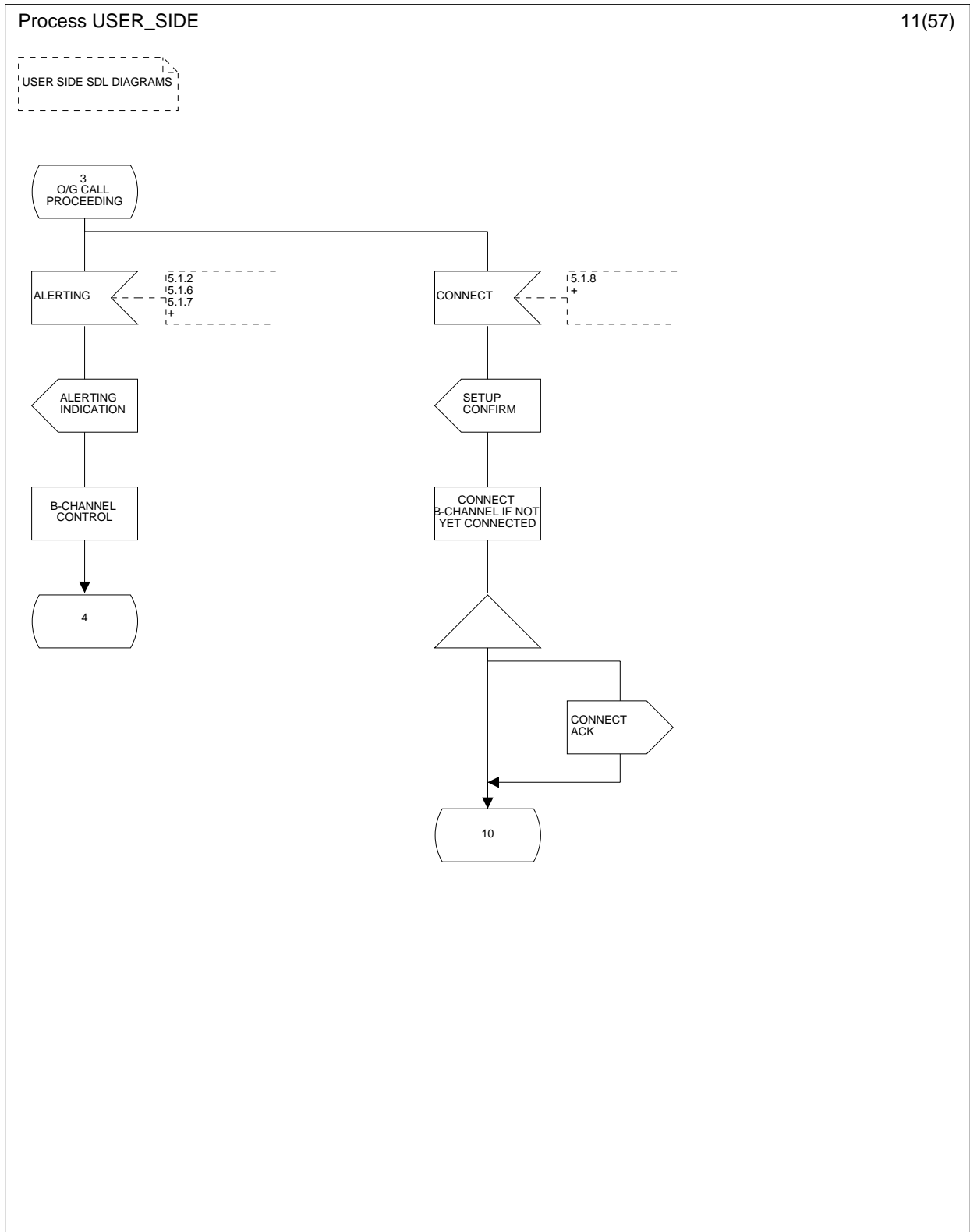

Figure 6 (sheet 11 of 57): User side SDL diagram



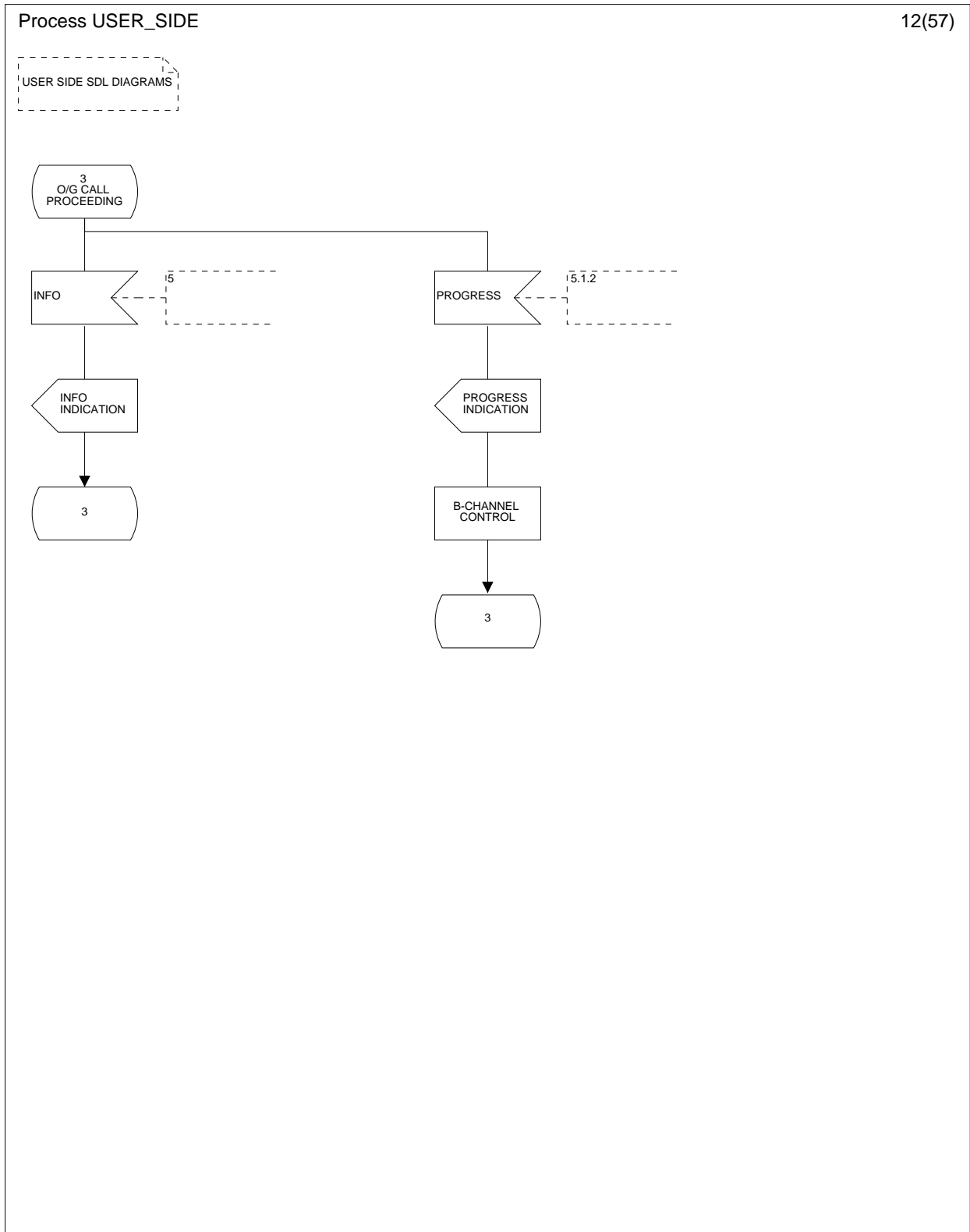

Figure 6 (sheet 12 of 57): User side SDL diagram

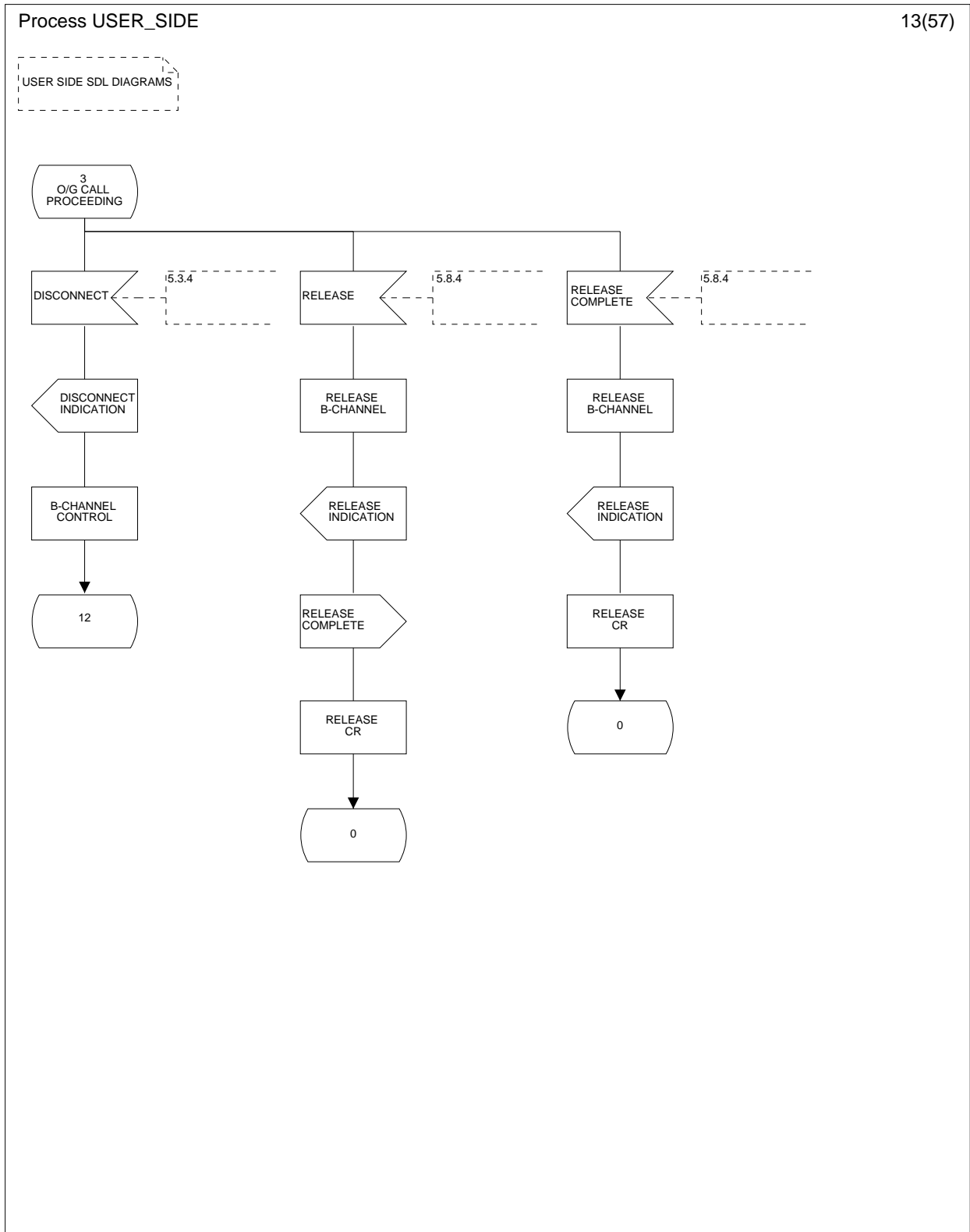

Figure 6 (sheet 13 of 57): User side SDL diagram

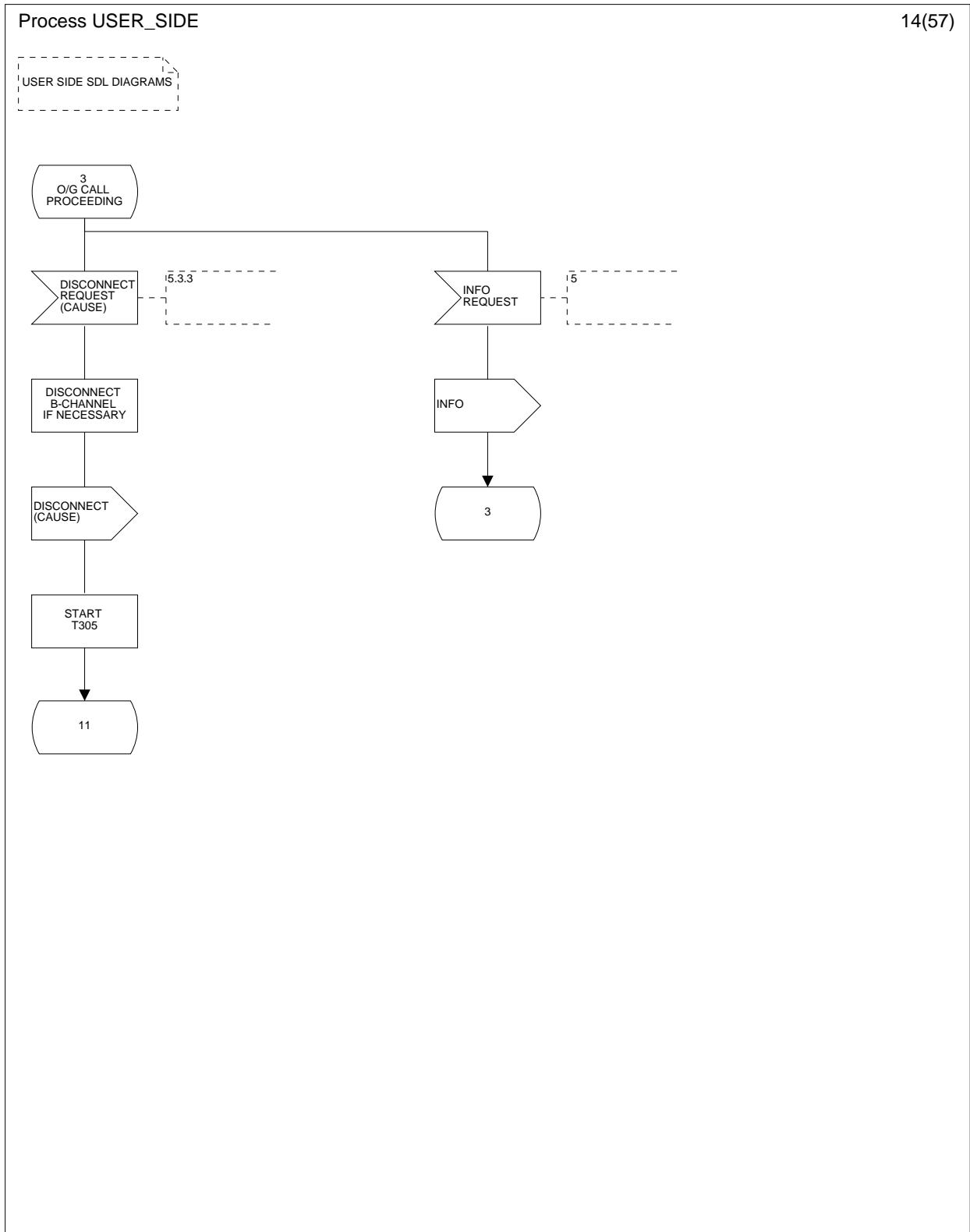

Figure 6 (sheet 14 of 57): User side SDL diagram

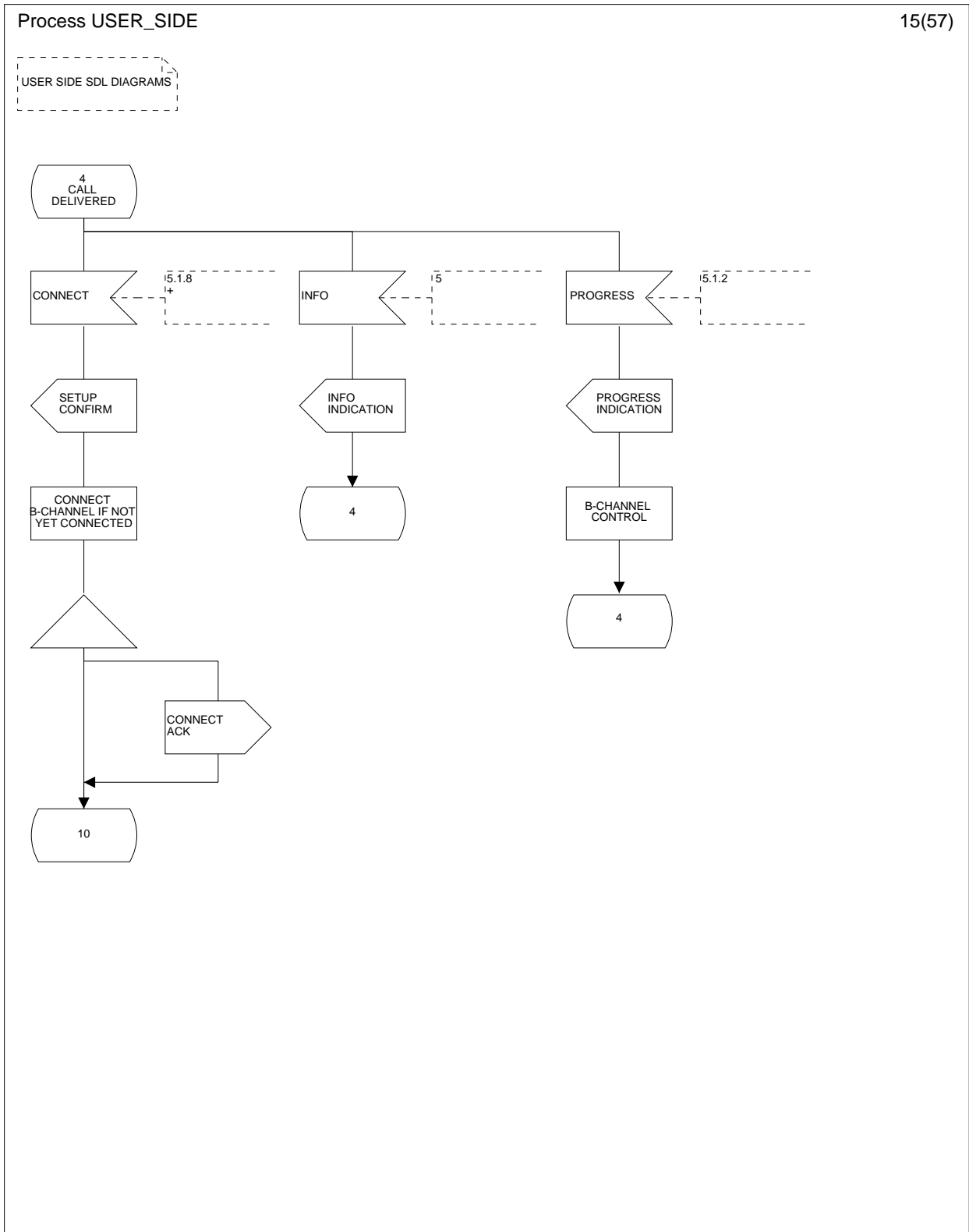

Figure 6 (sheet 15 of 57): User side SDL diagram

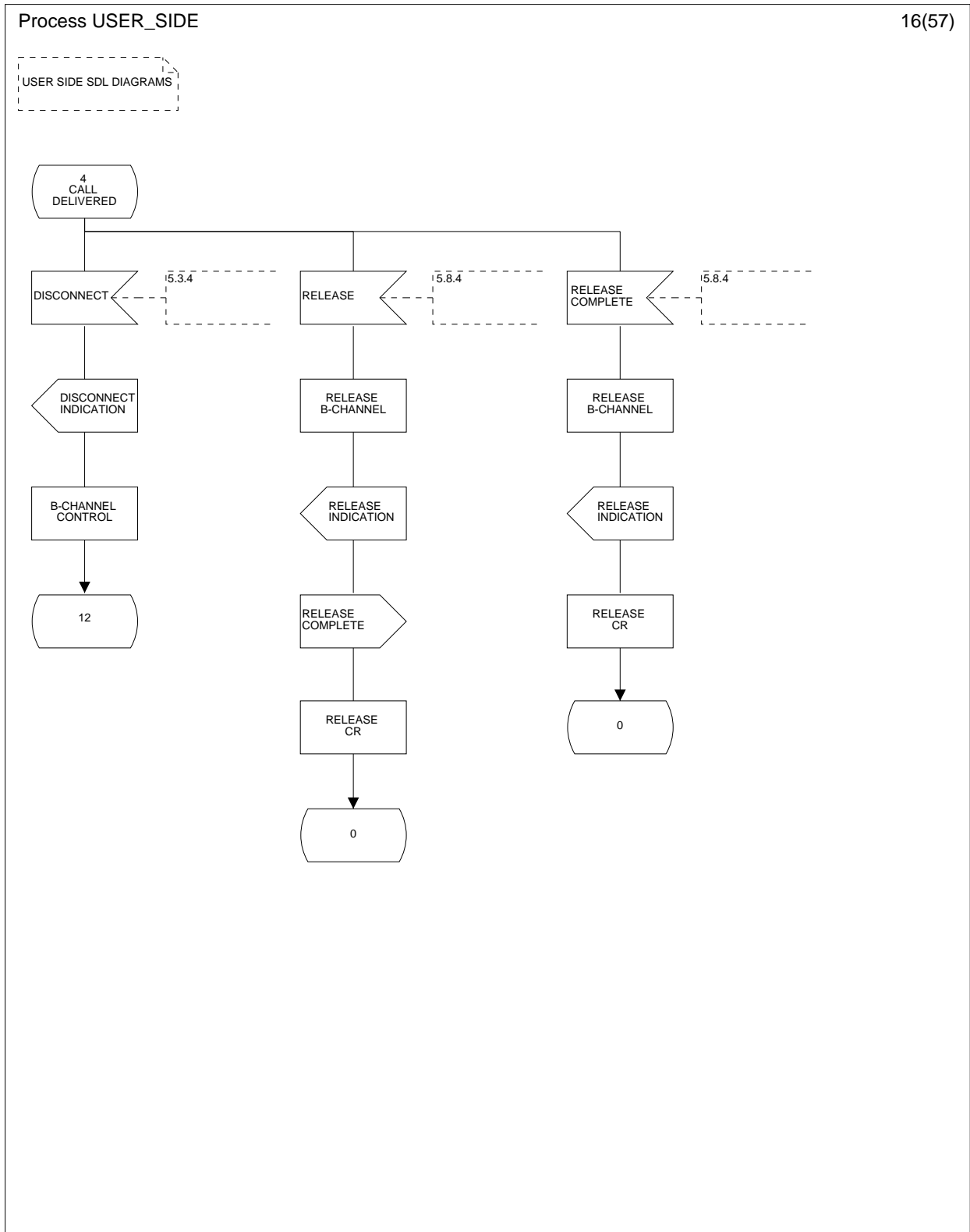

Figure 6 (sheet 16 of 57): User side SDL diagram

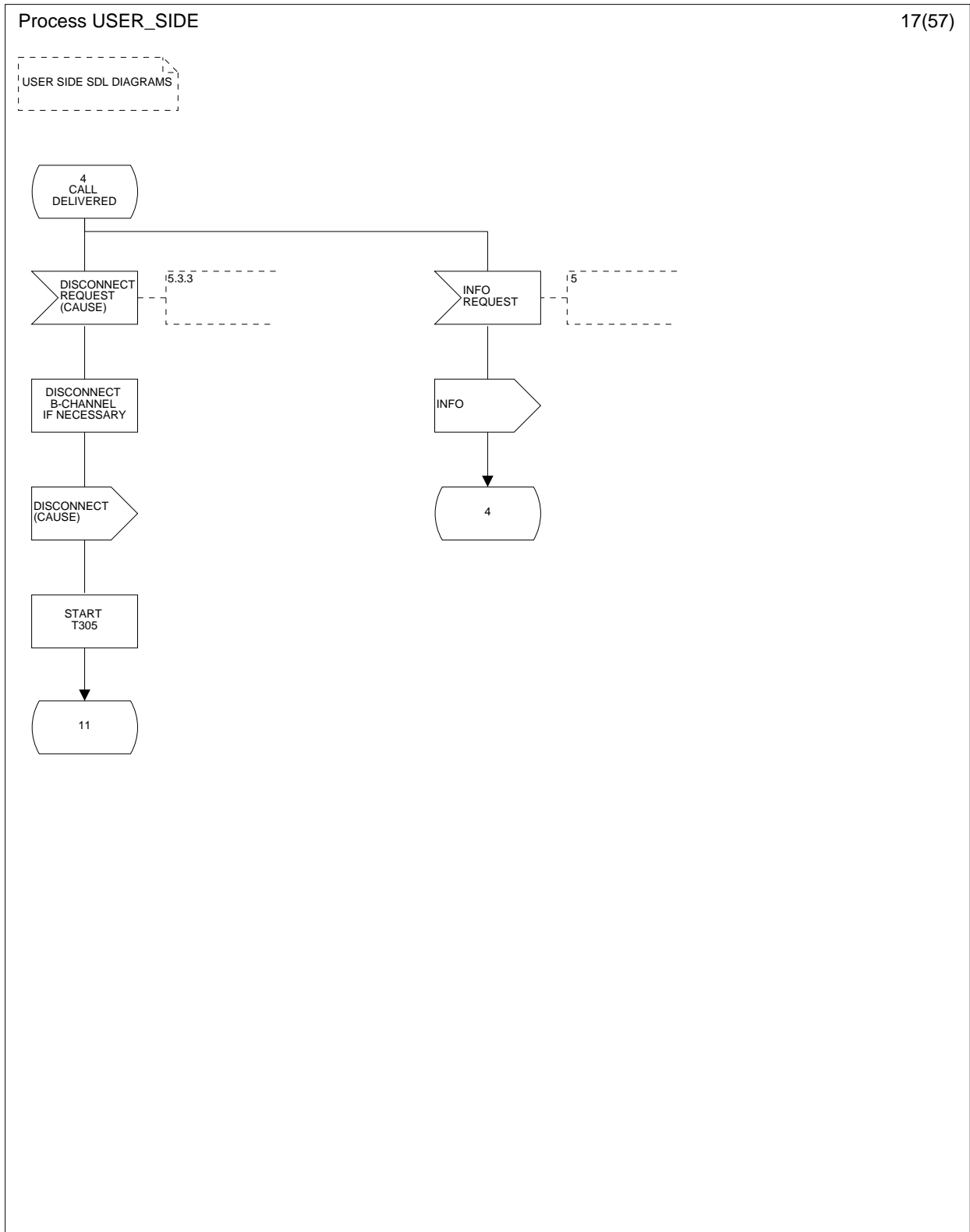

Figure 6 (sheet 17 of 57): User side SDL diagram

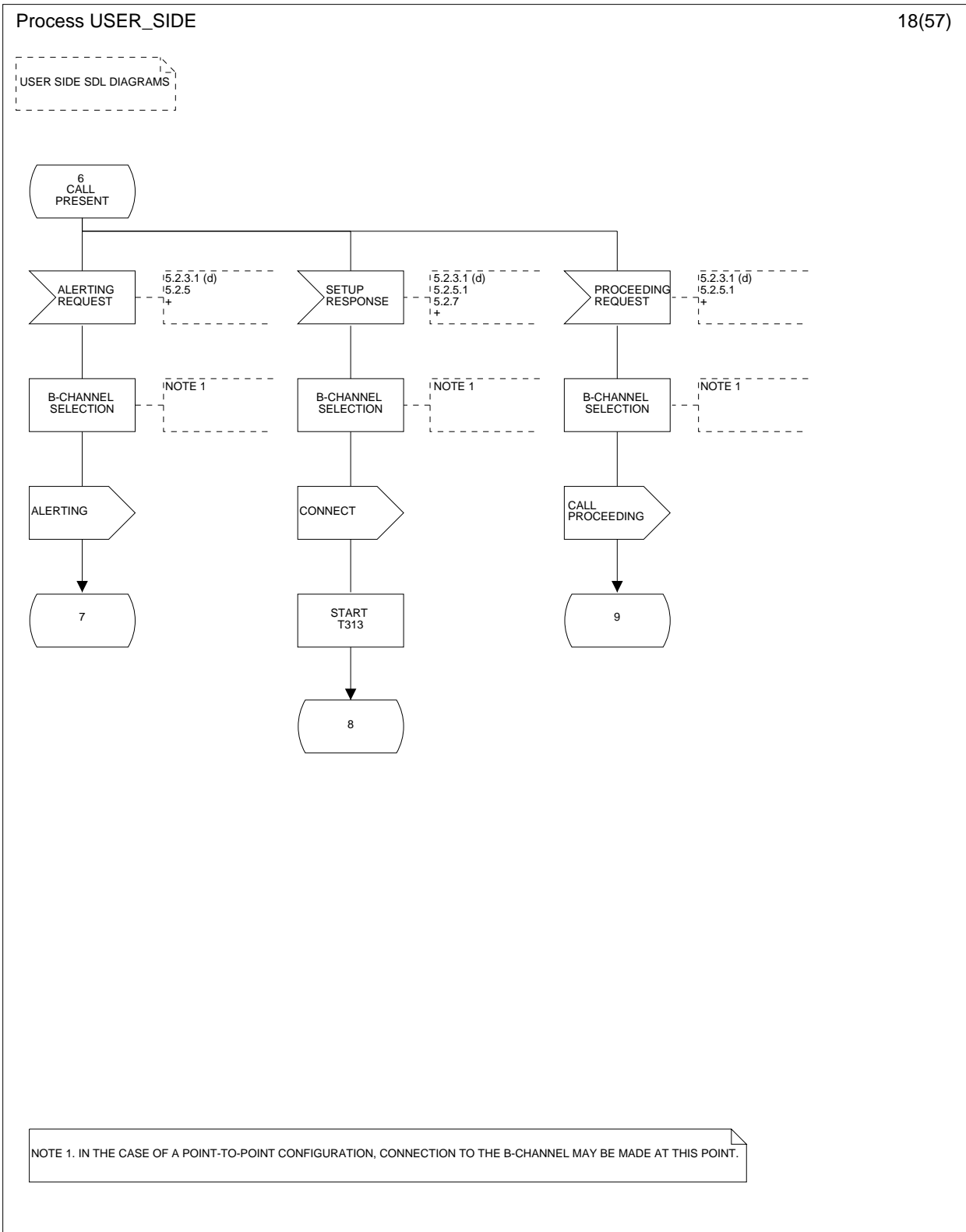

Figure 6 (sheet 18 of 57): User side SDL diagram

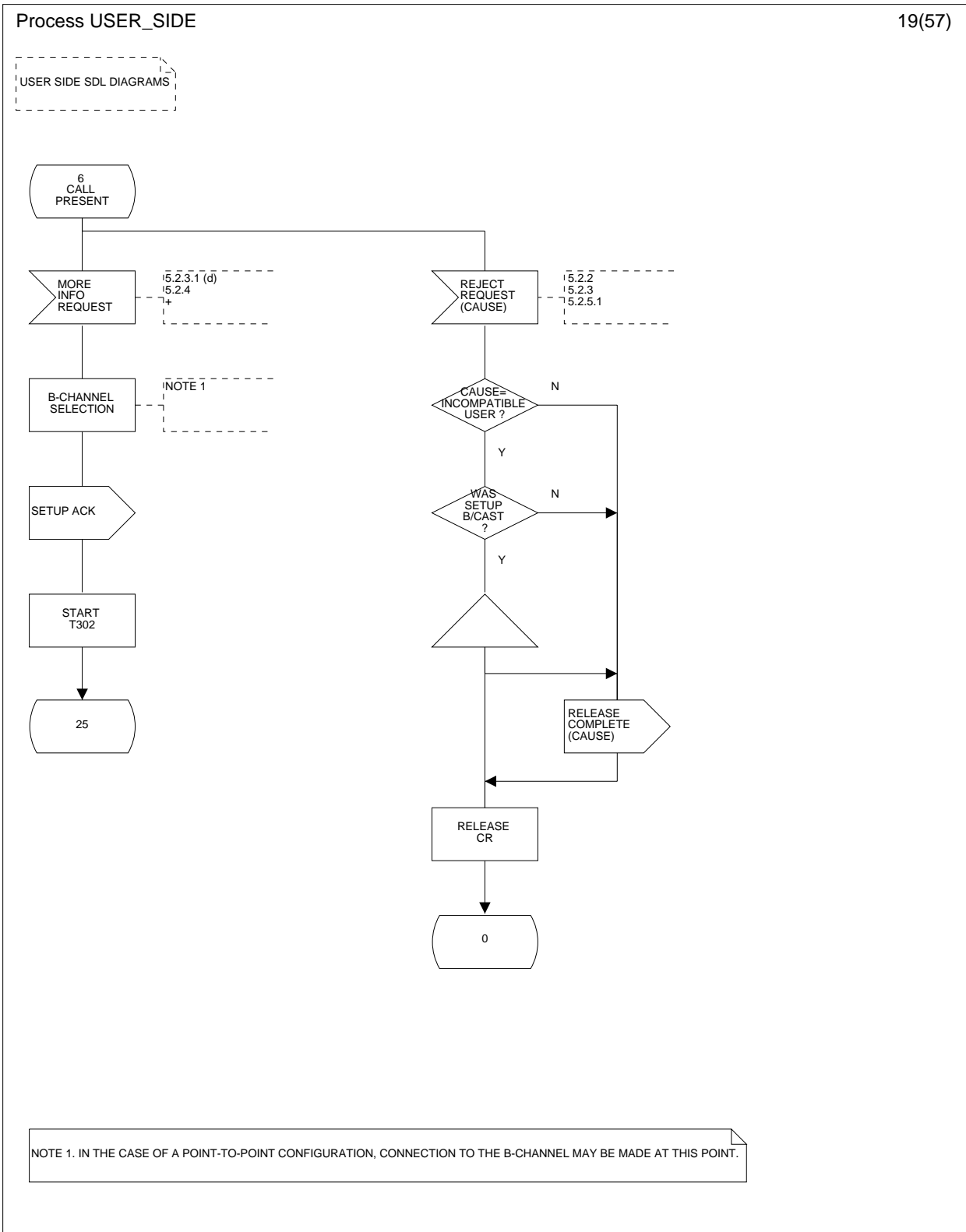

Figure 6 (sheet 19 of 57): User side SDL diagram



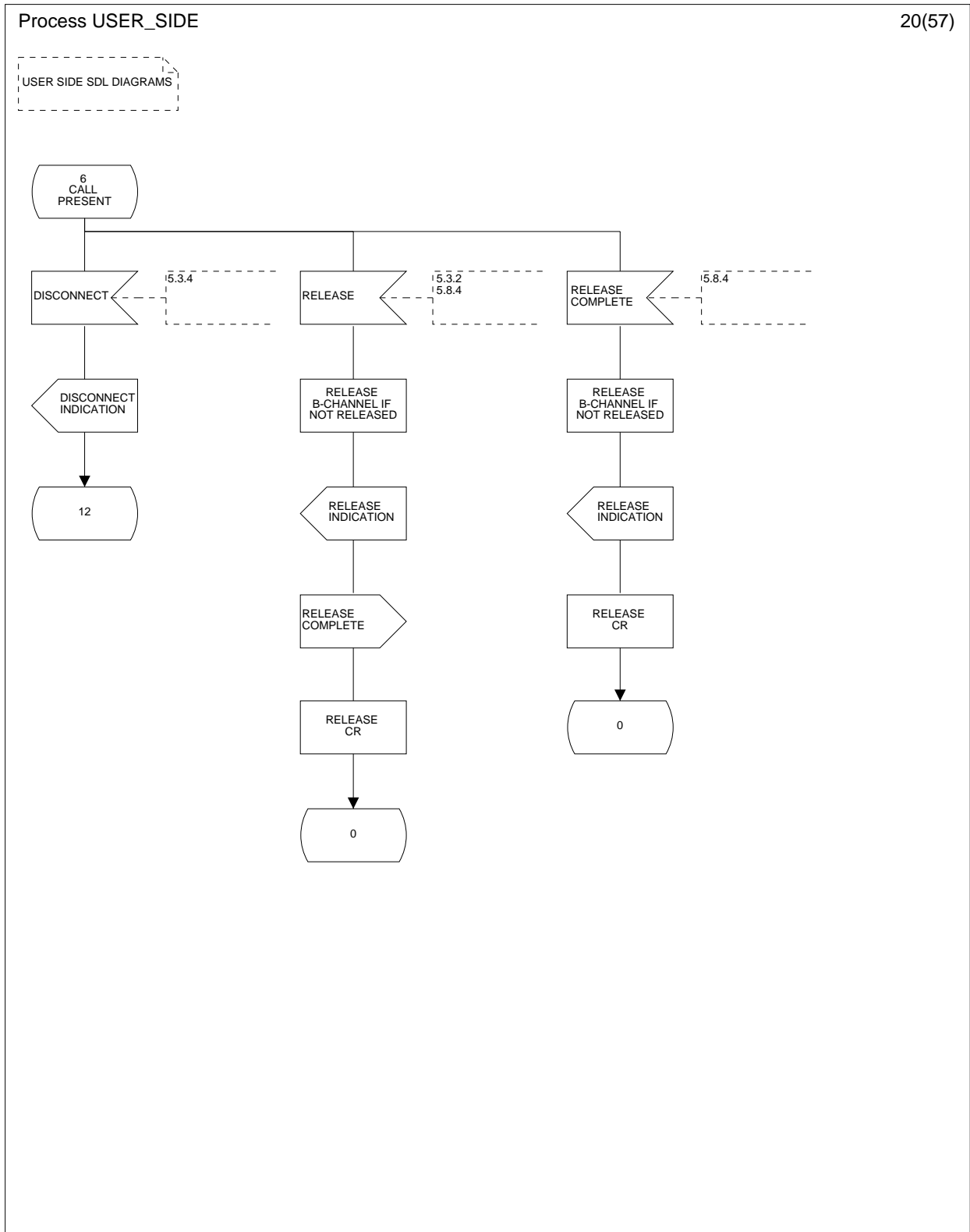

Figure 6 (sheet 20 of 57): User side SDL diagram

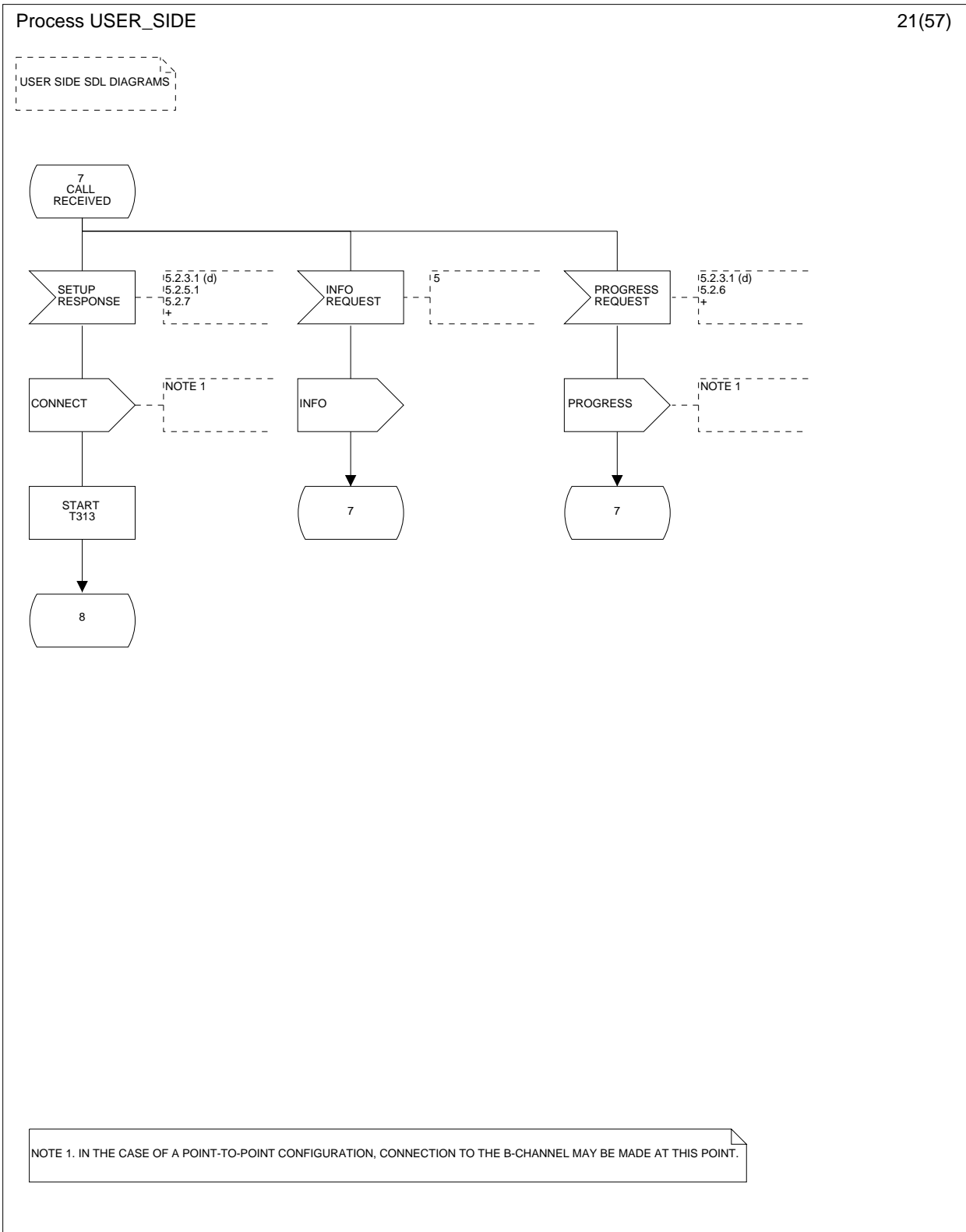

Figure 6 (sheet 21 of 57): User side SDL diagram

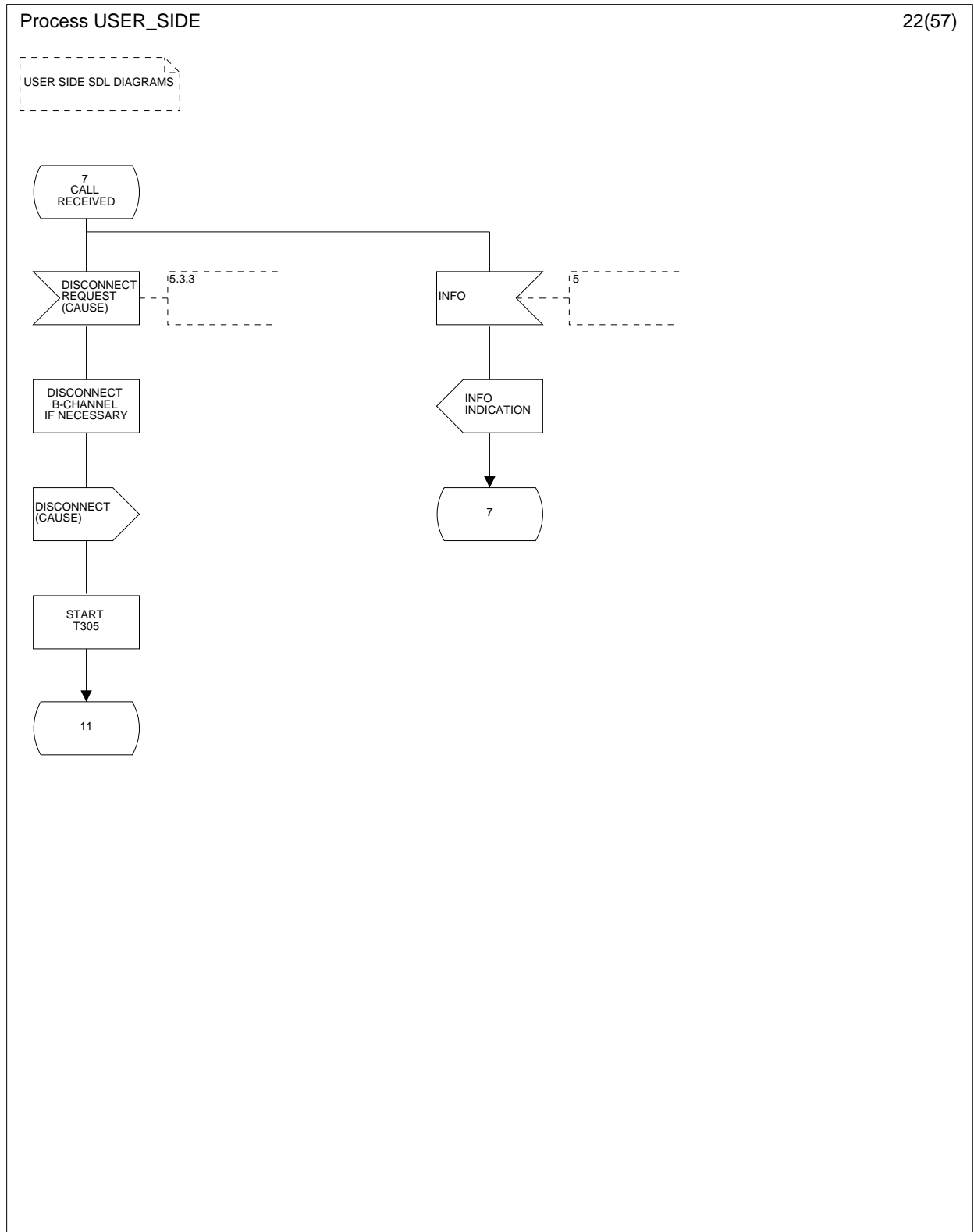

Figure 6 (sheet 22 of 57): User side SDL diagram

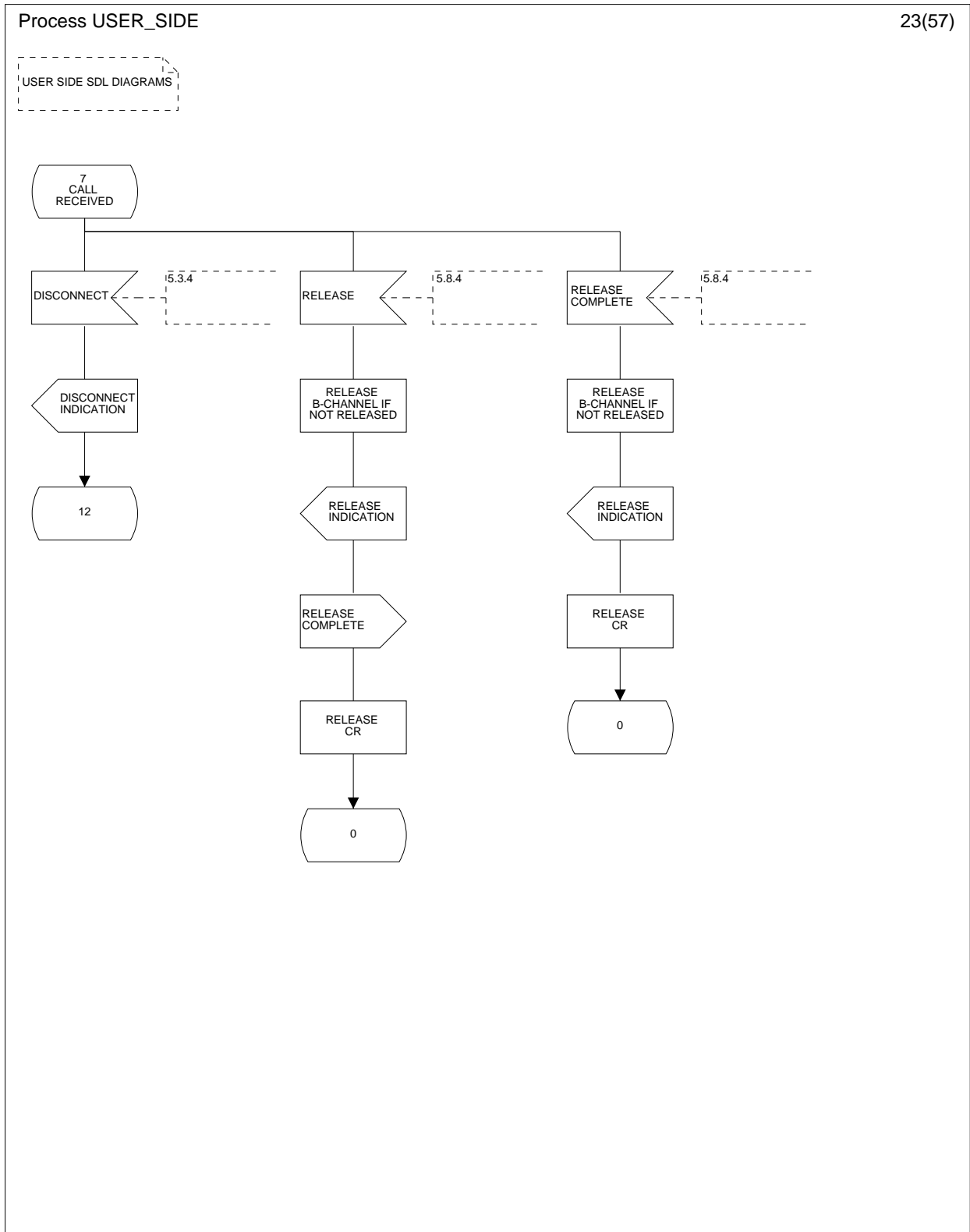

Figure 6 (sheet 23 of 57): User side SDL diagram

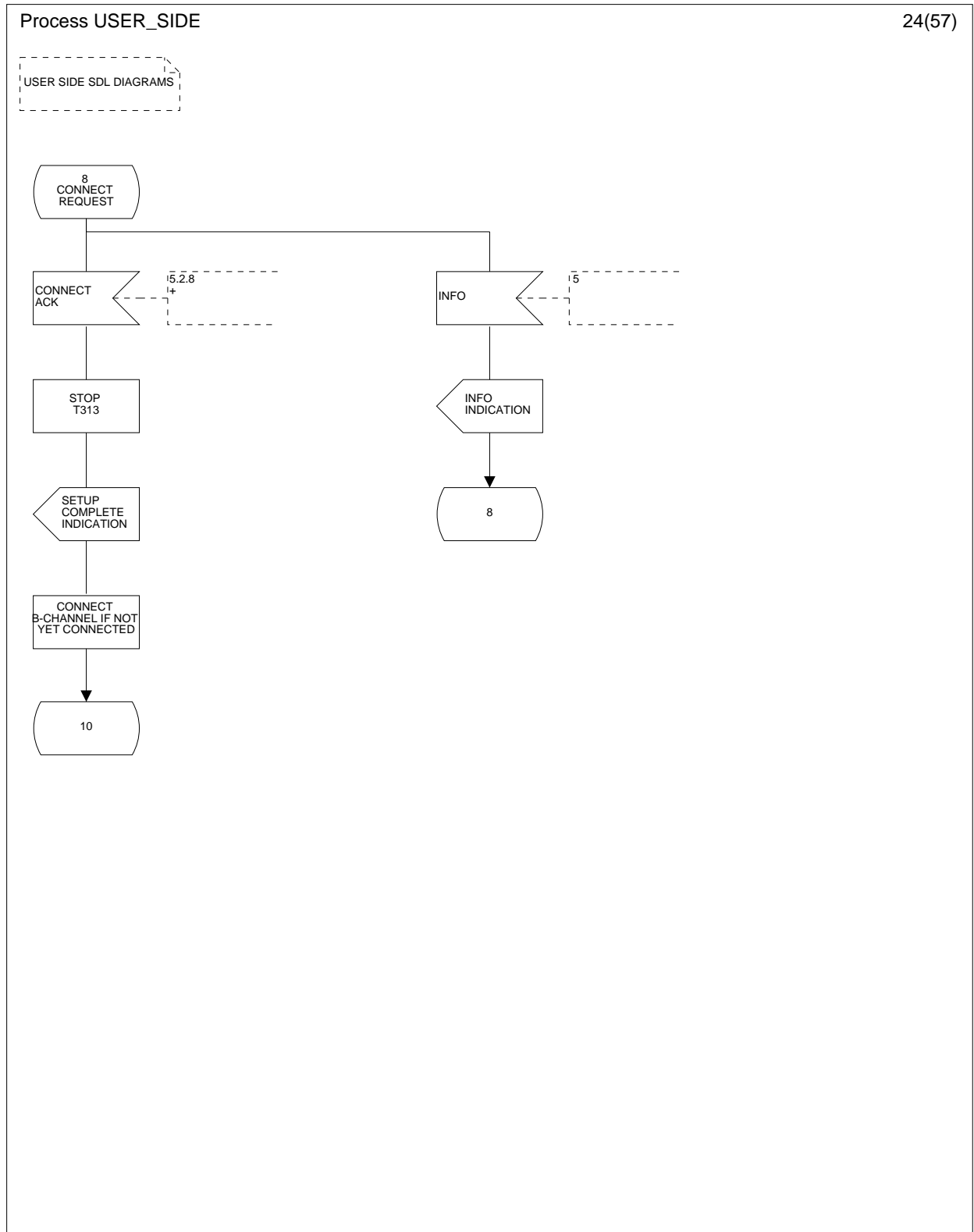

Figure 6 (sheet 24 of 57): User side SDL diagram

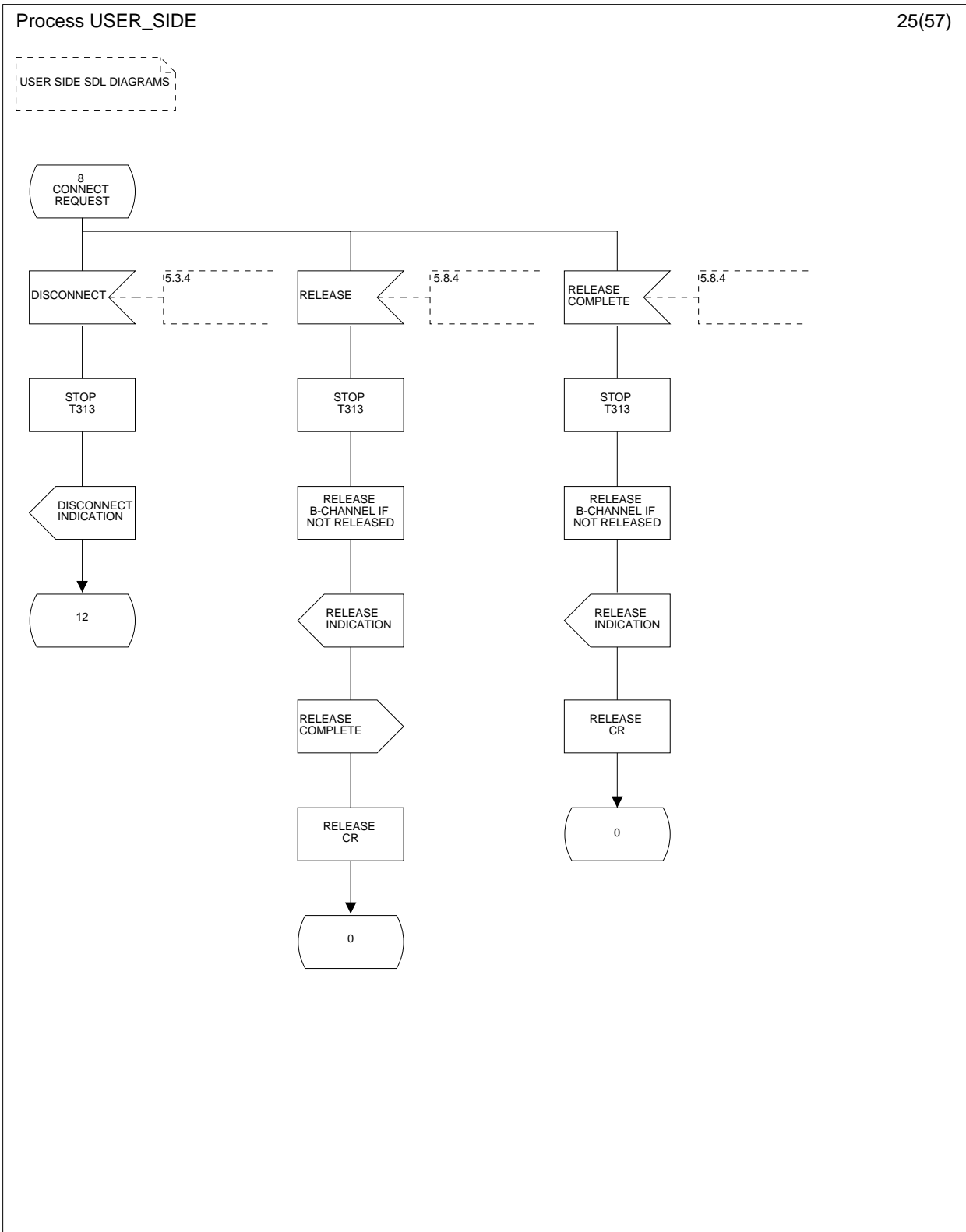

Figure 6 (sheet 25 of 57): User side SDL diagram

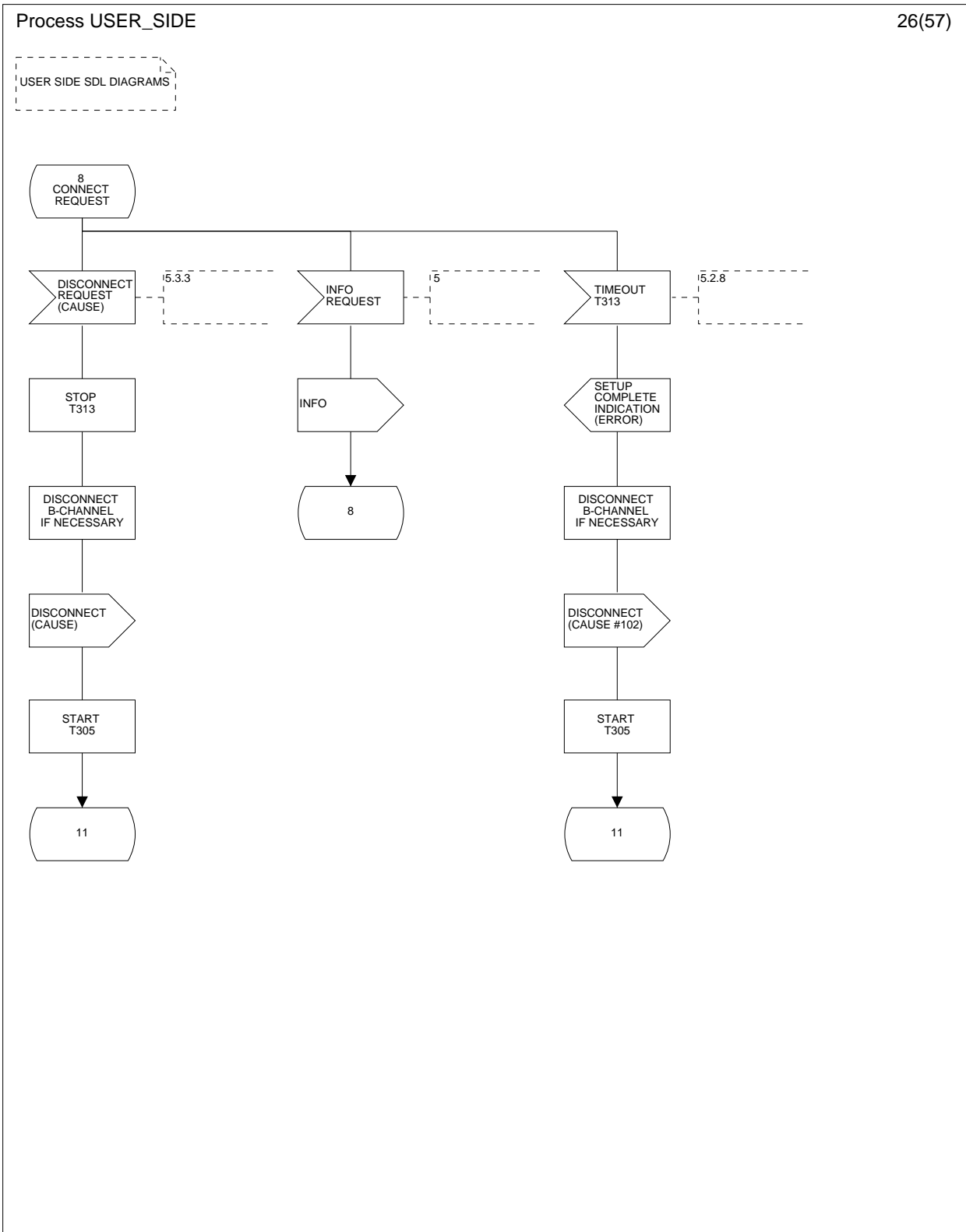
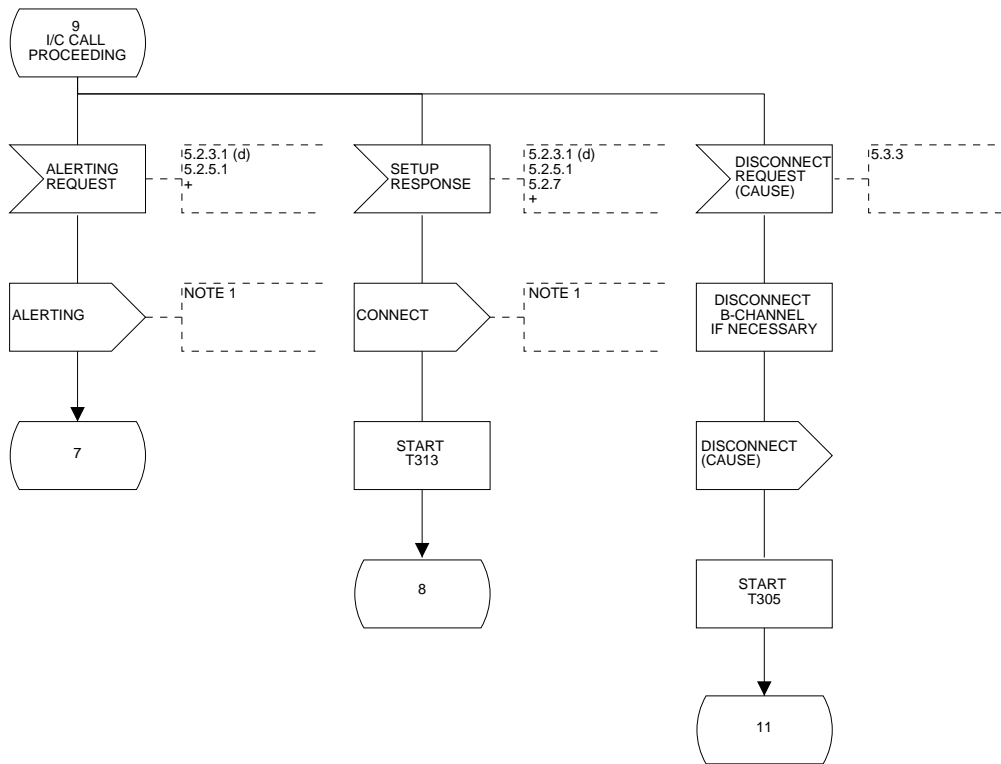

Figure 6 (sheet 26 of 57): User side SDL diagram

Process USER\_SIDE

27(57)

USER SIDE SDL DIAGRAMS



NOTE 1. IN THE CASE OF A POINT-TO-POINT CONFIGURATION, CONNECTION TO THE B-CHANNEL MAY BE MADE AT THIS POINT.

Figure 6 (sheet 27 of 57): User side SDL diagram



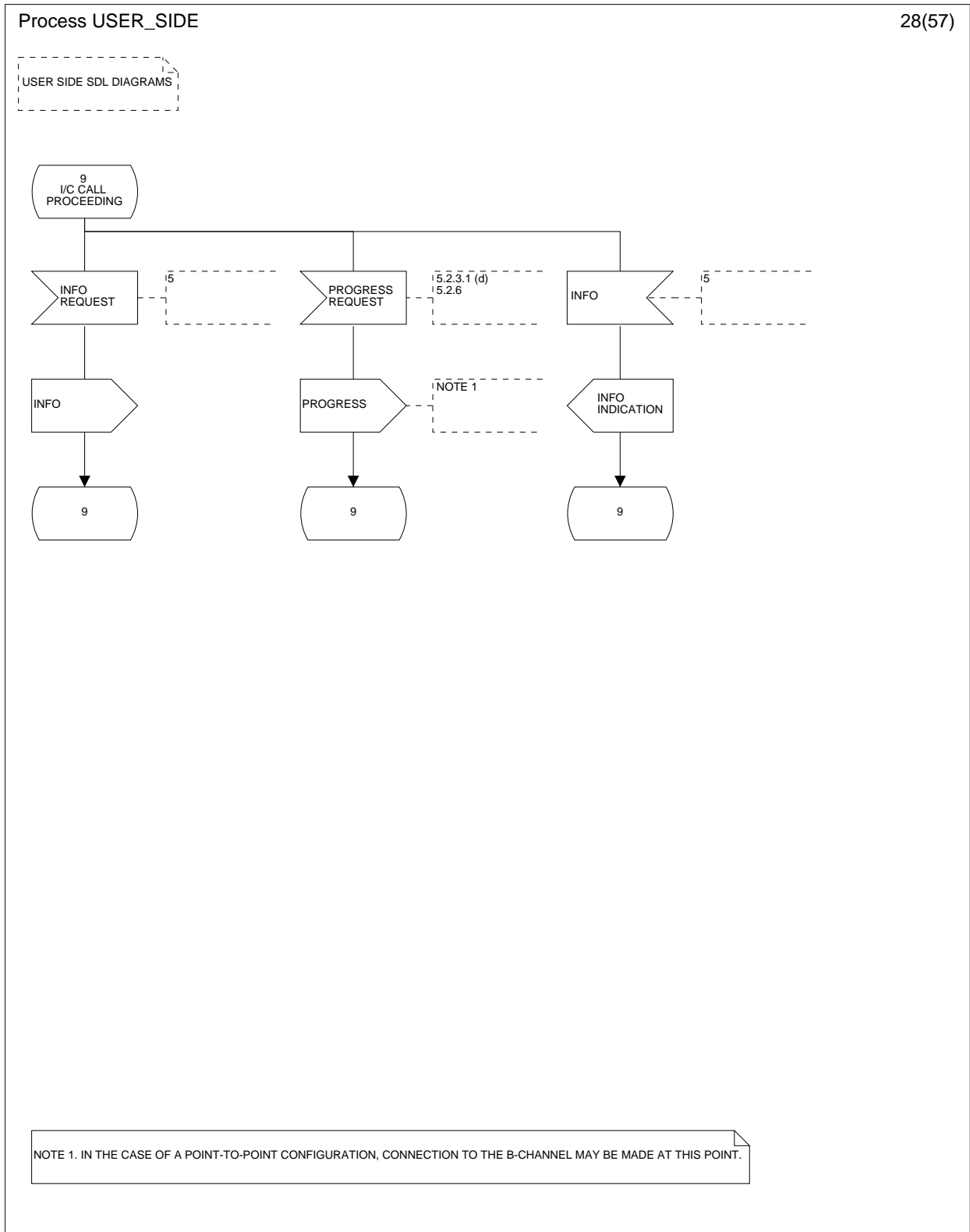

Figure 6 (sheet 28 of 57): User side SDL diagram

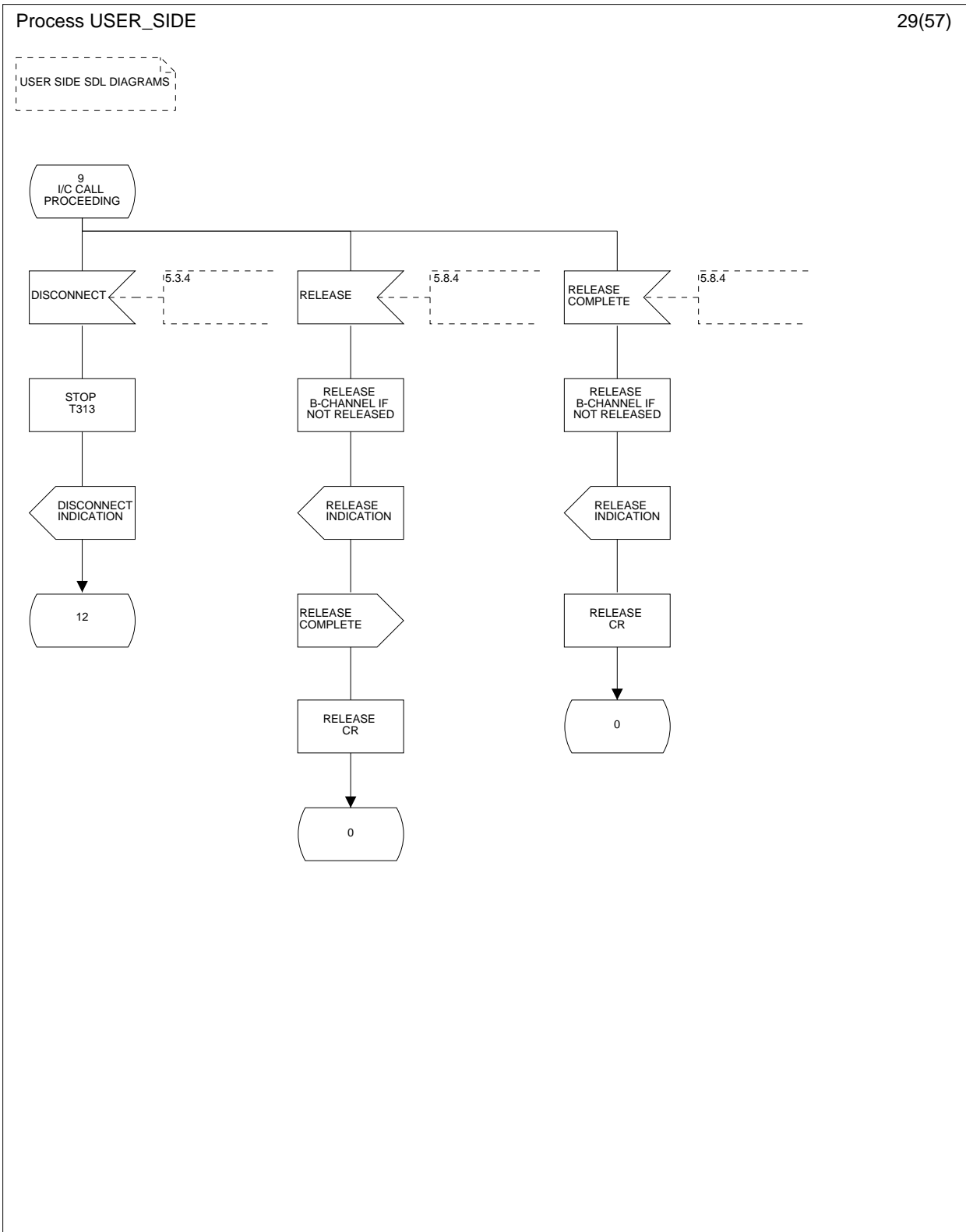

Figure 6 (sheet 29 of 57): User side SDL diagram

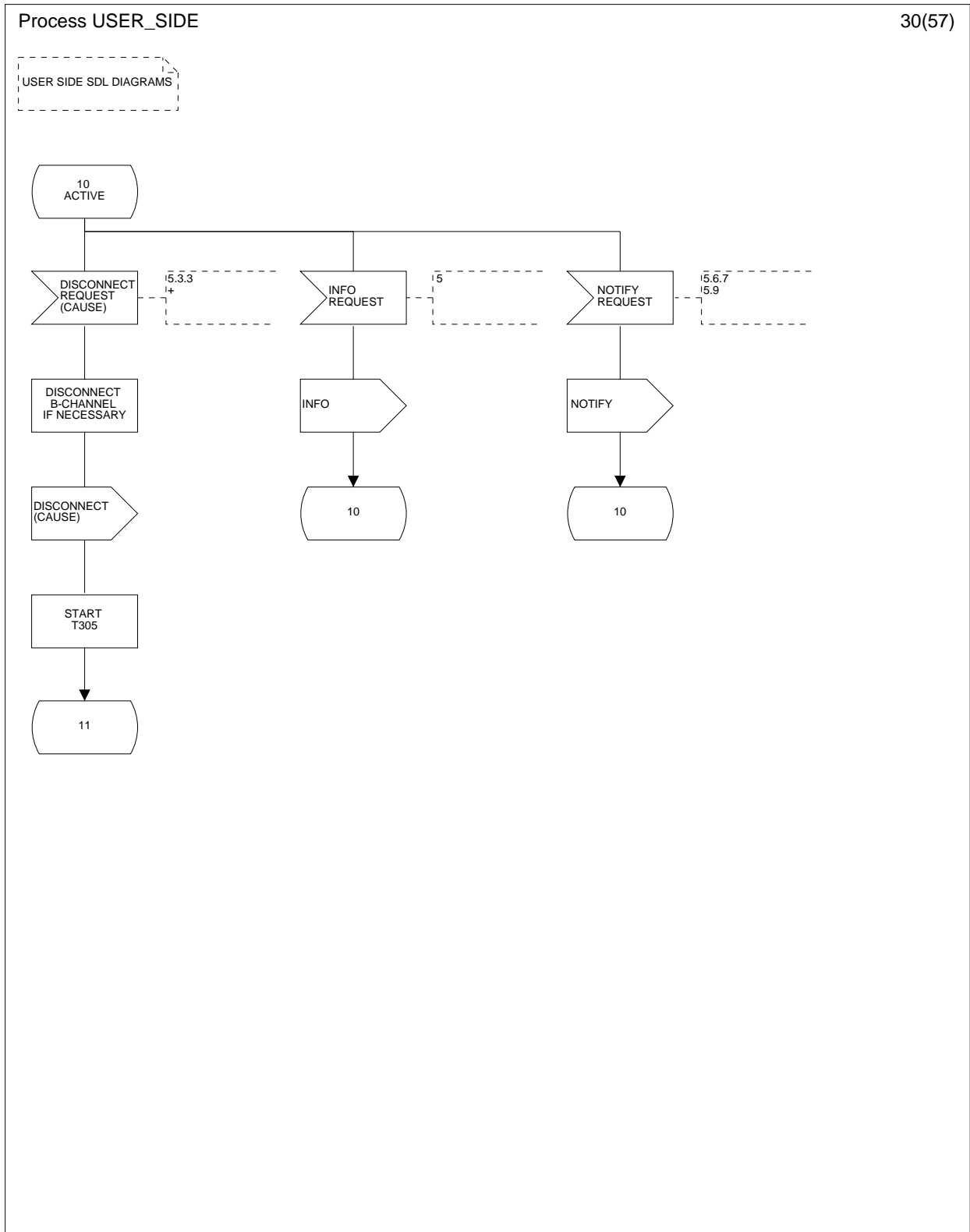

Figure 6 (sheet 30 of 57): User side SDL diagram

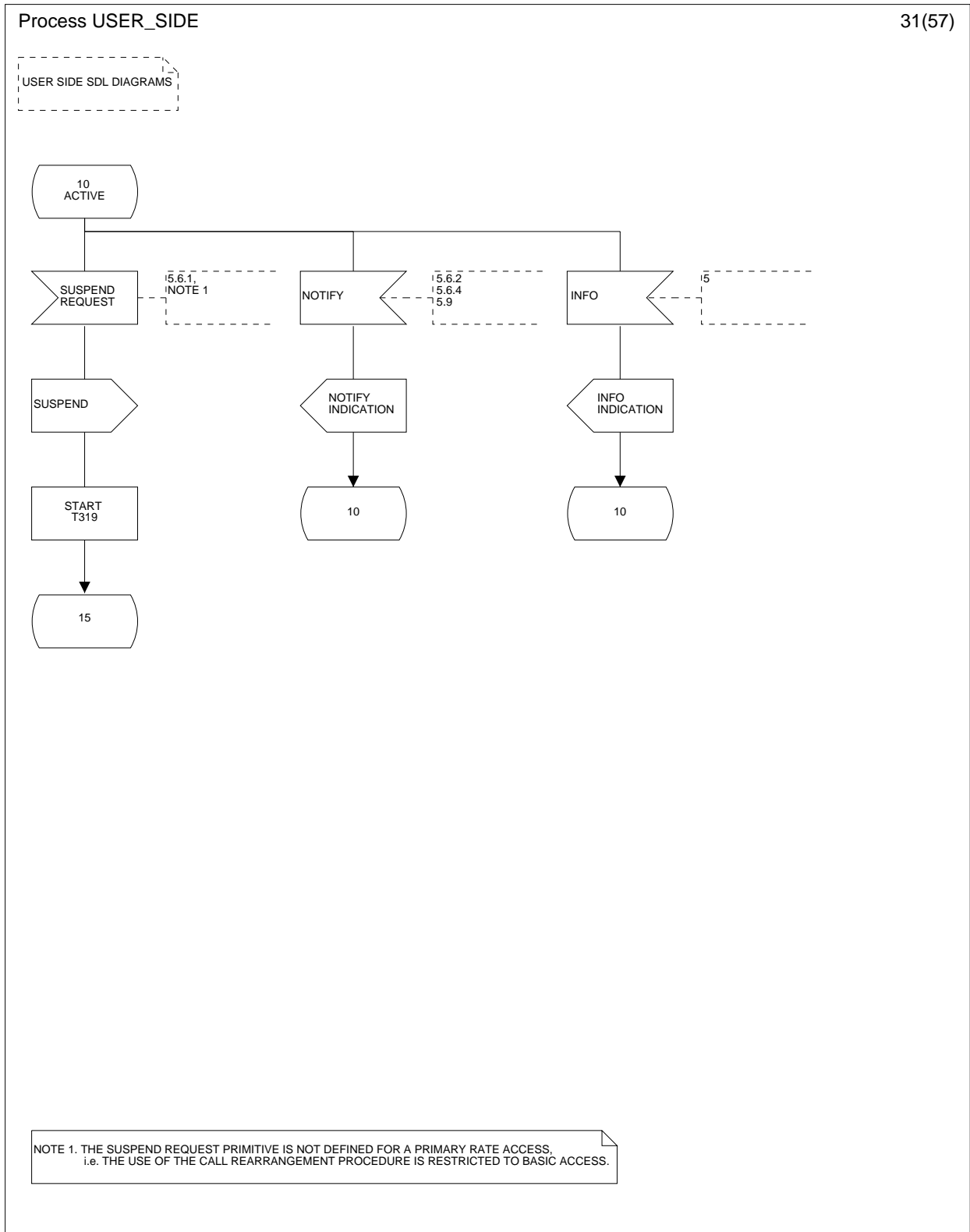

Figure 6 (sheet 31 of 57): User side SDL diagram

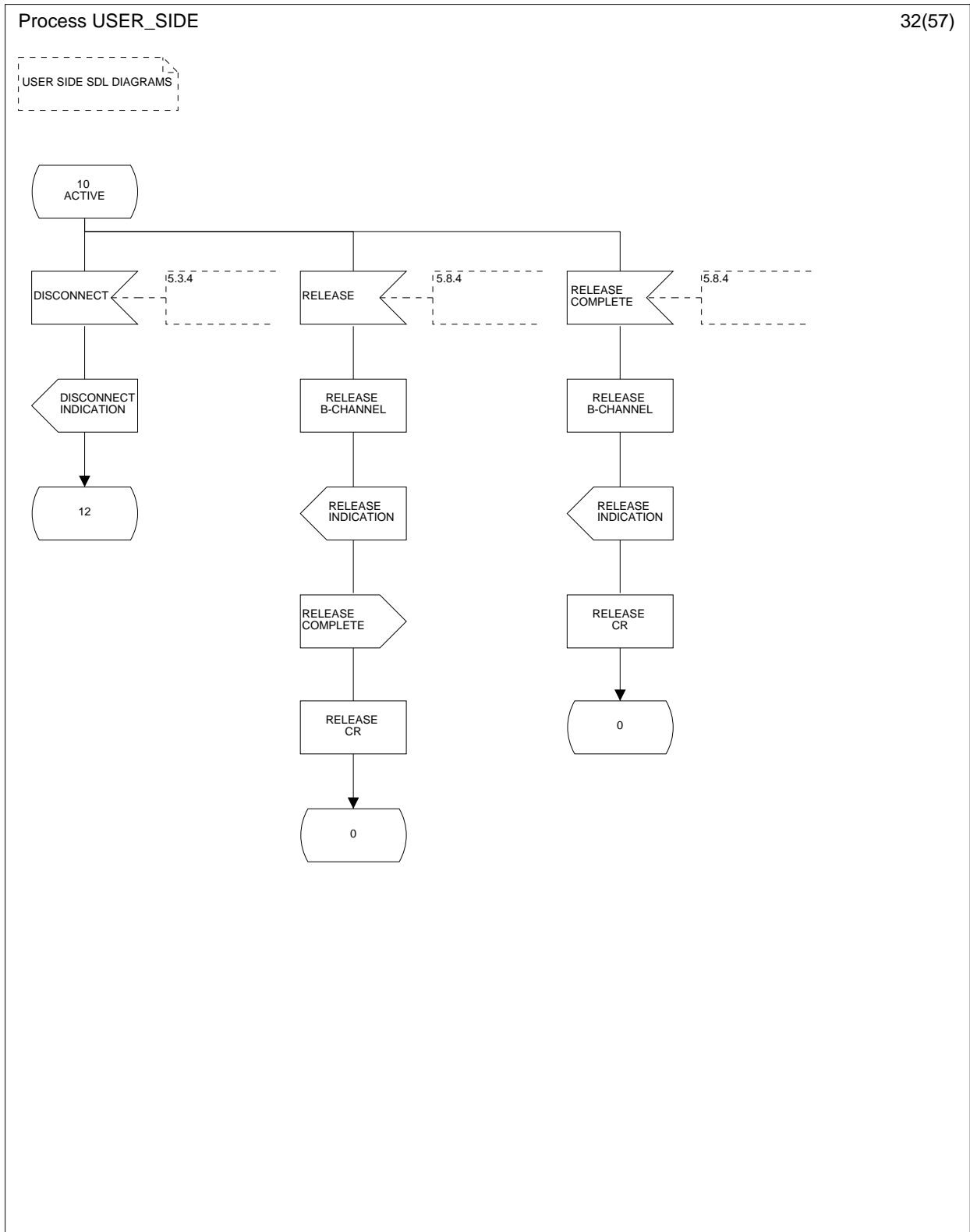

Figure 6 (sheet 32 of 57): User side SDL diagram

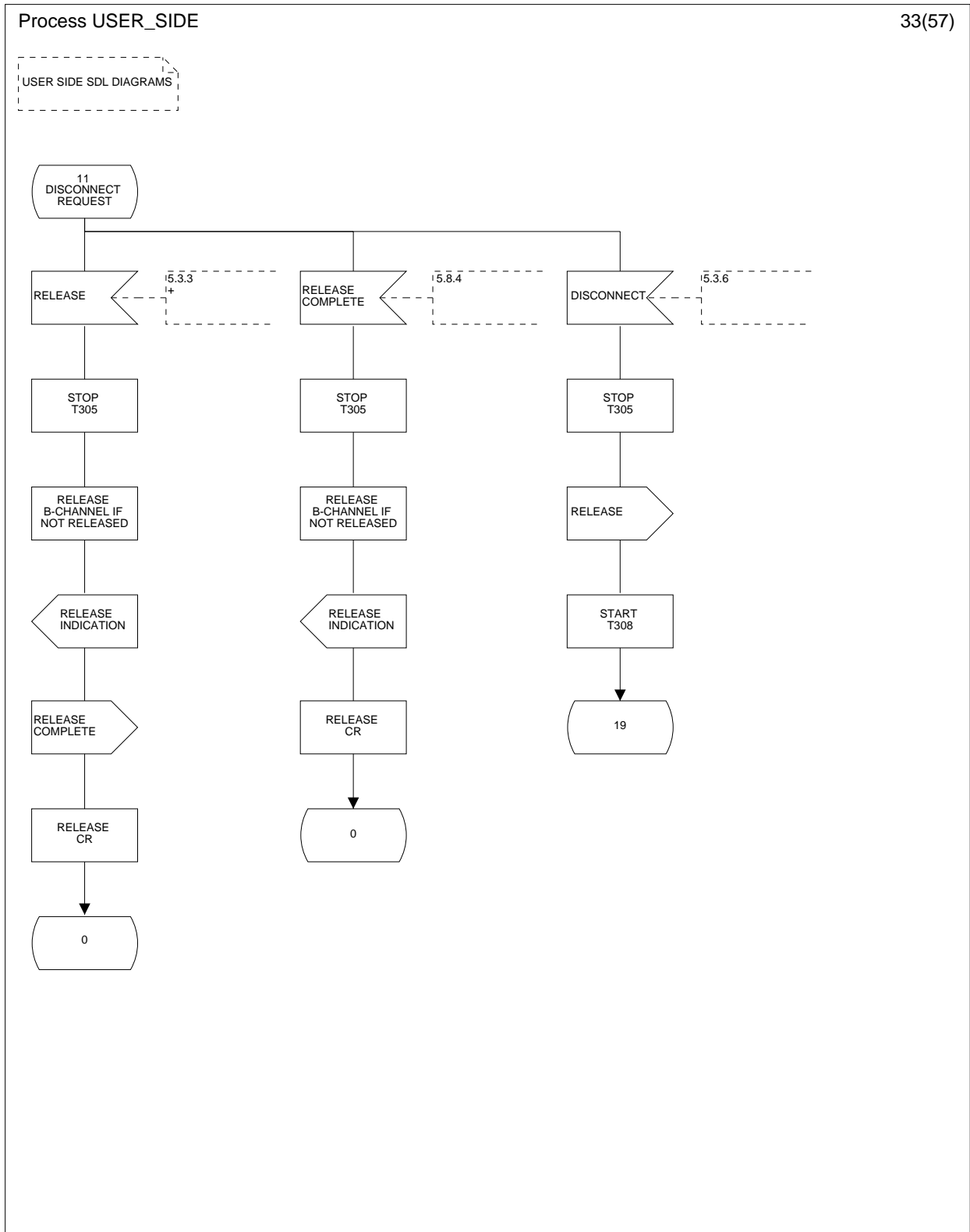

Figure 6 (sheet 33 of 57): User side SDL diagram

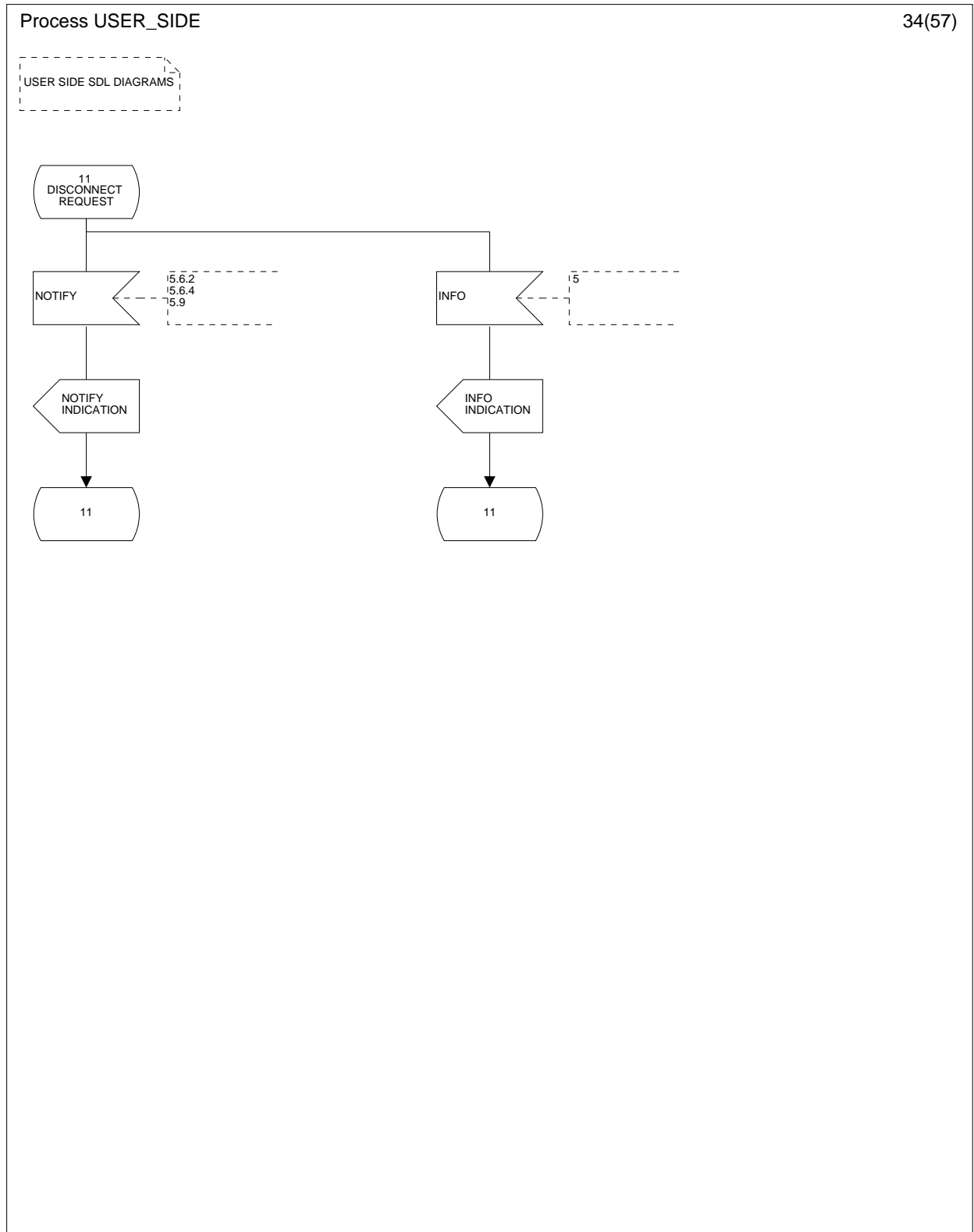

Figure 6 (sheet 34 of 57): User side SDL diagram

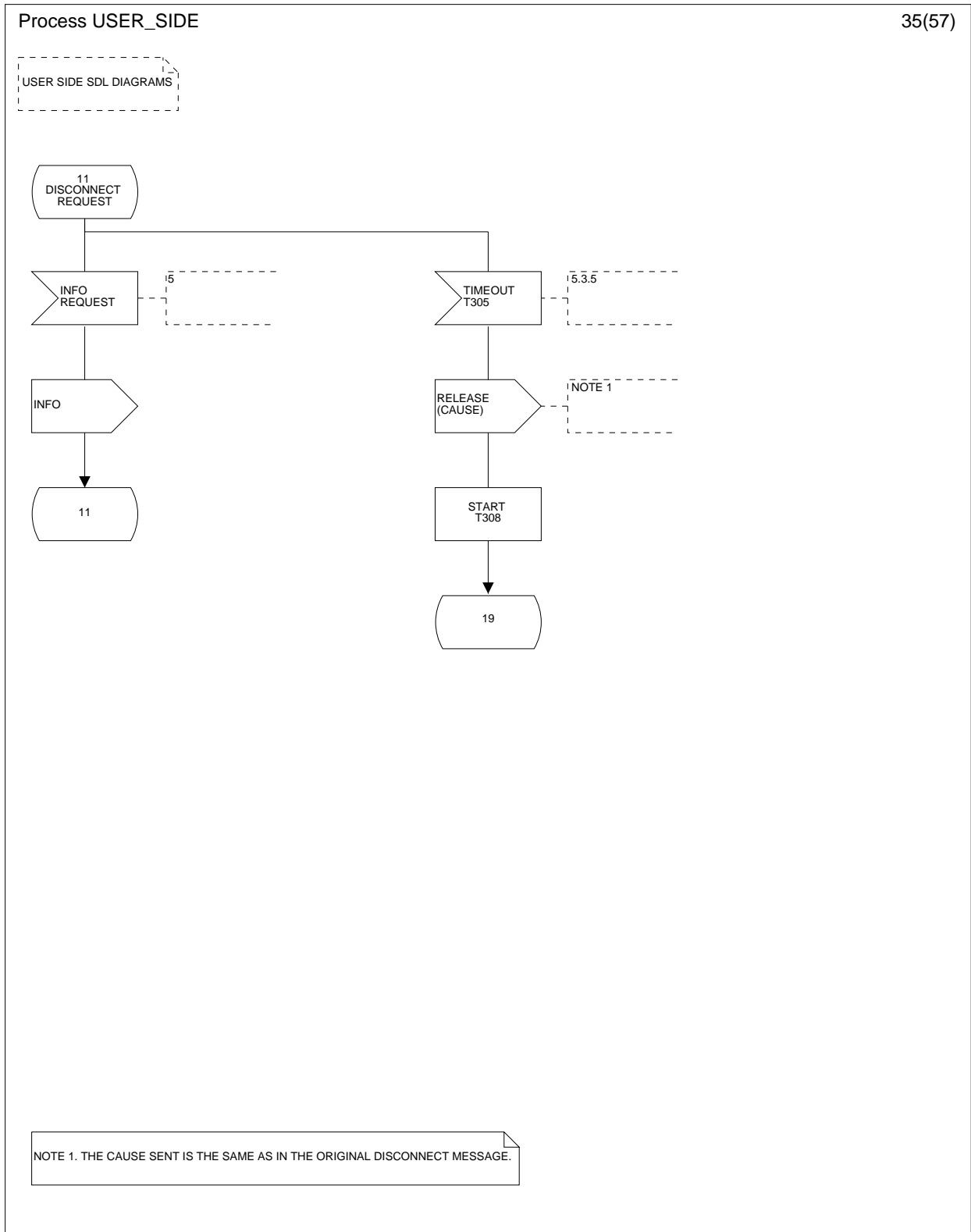

Figure 6 (sheet 35 of 57): User side SDL diagram



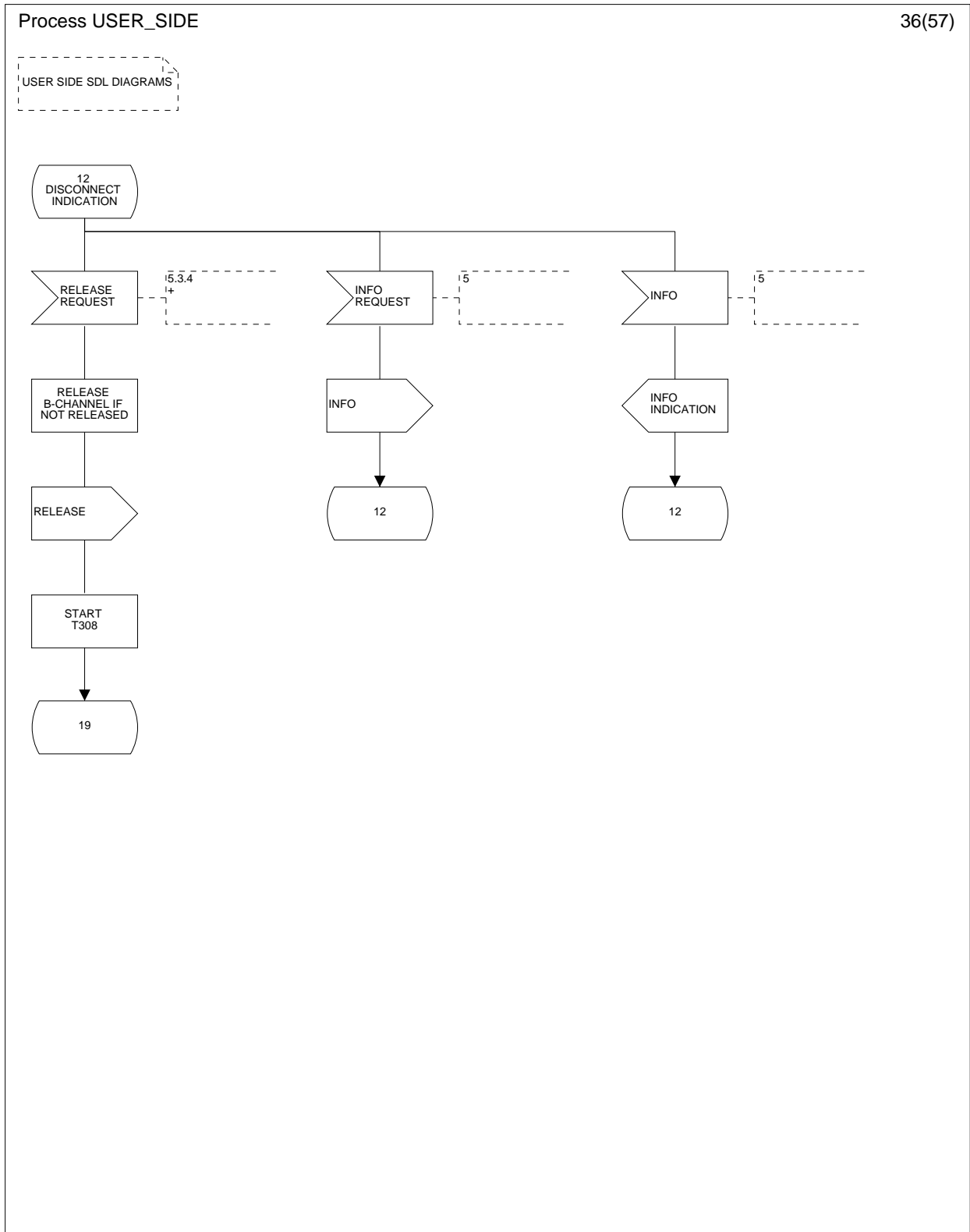

Figure 6 (sheet 36 of 57): User side SDL diagram

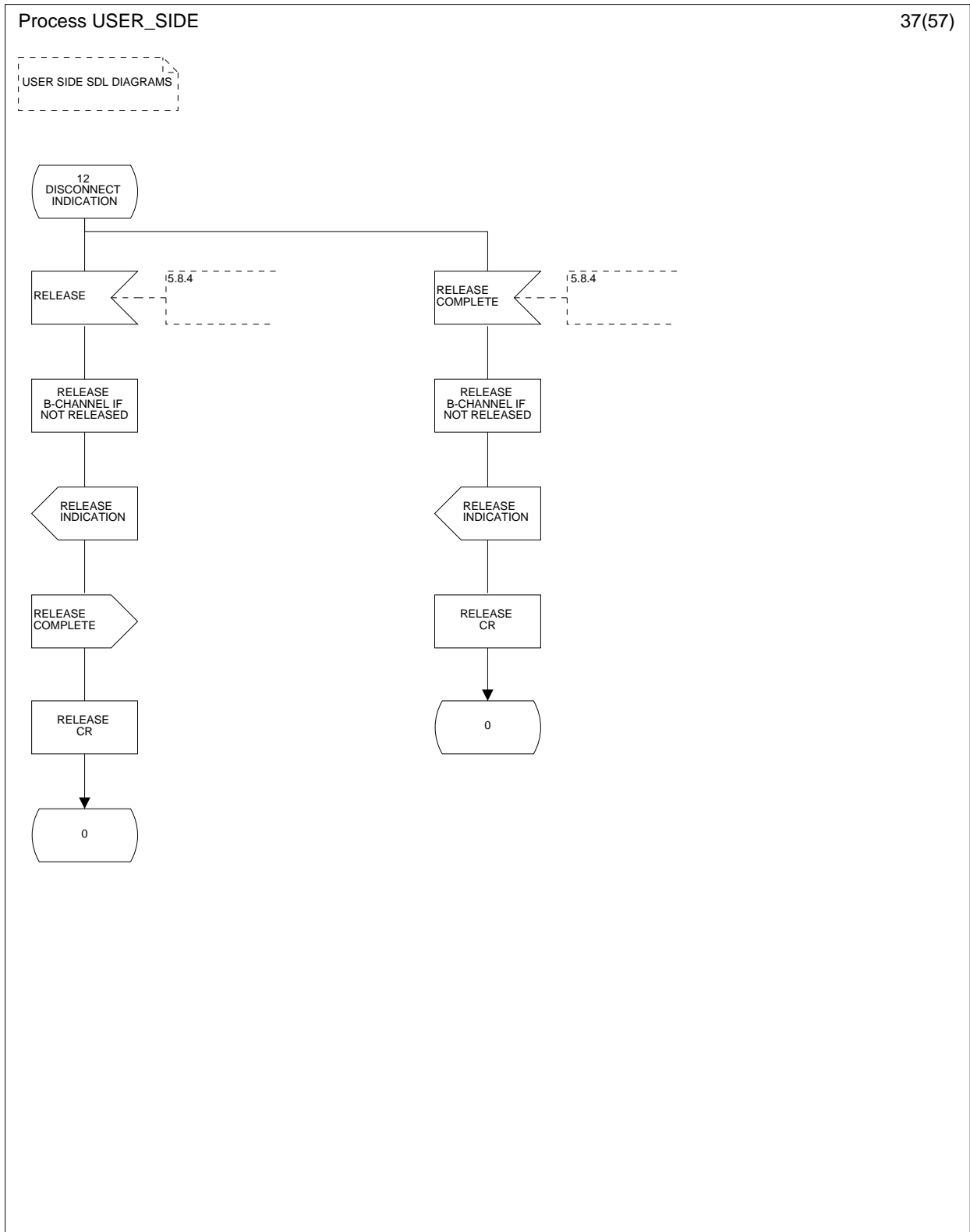

Figure 6 (sheet 37 of 57): User side SDL diagram

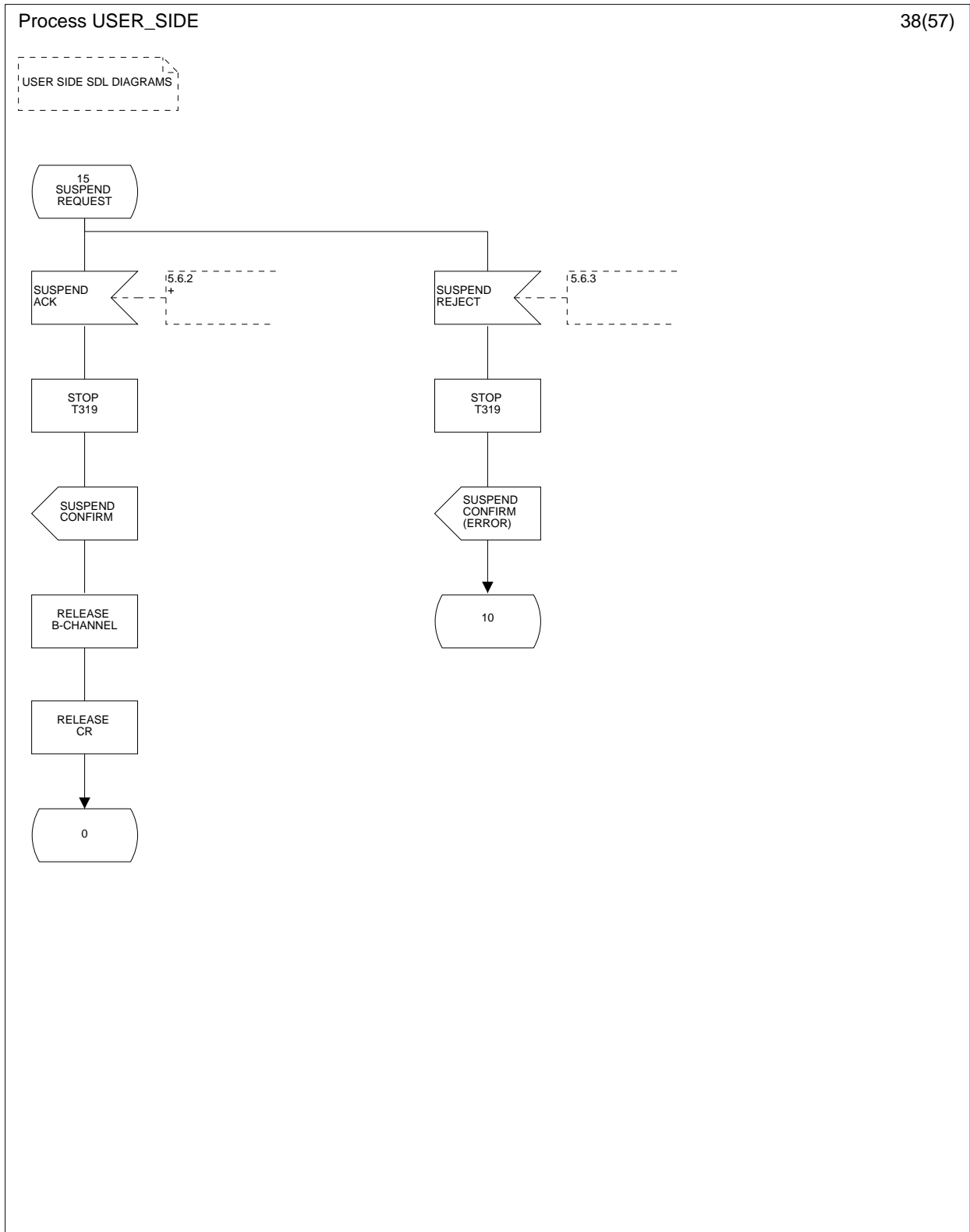

Figure 6 (sheet 38 of 57): User side SDL diagram

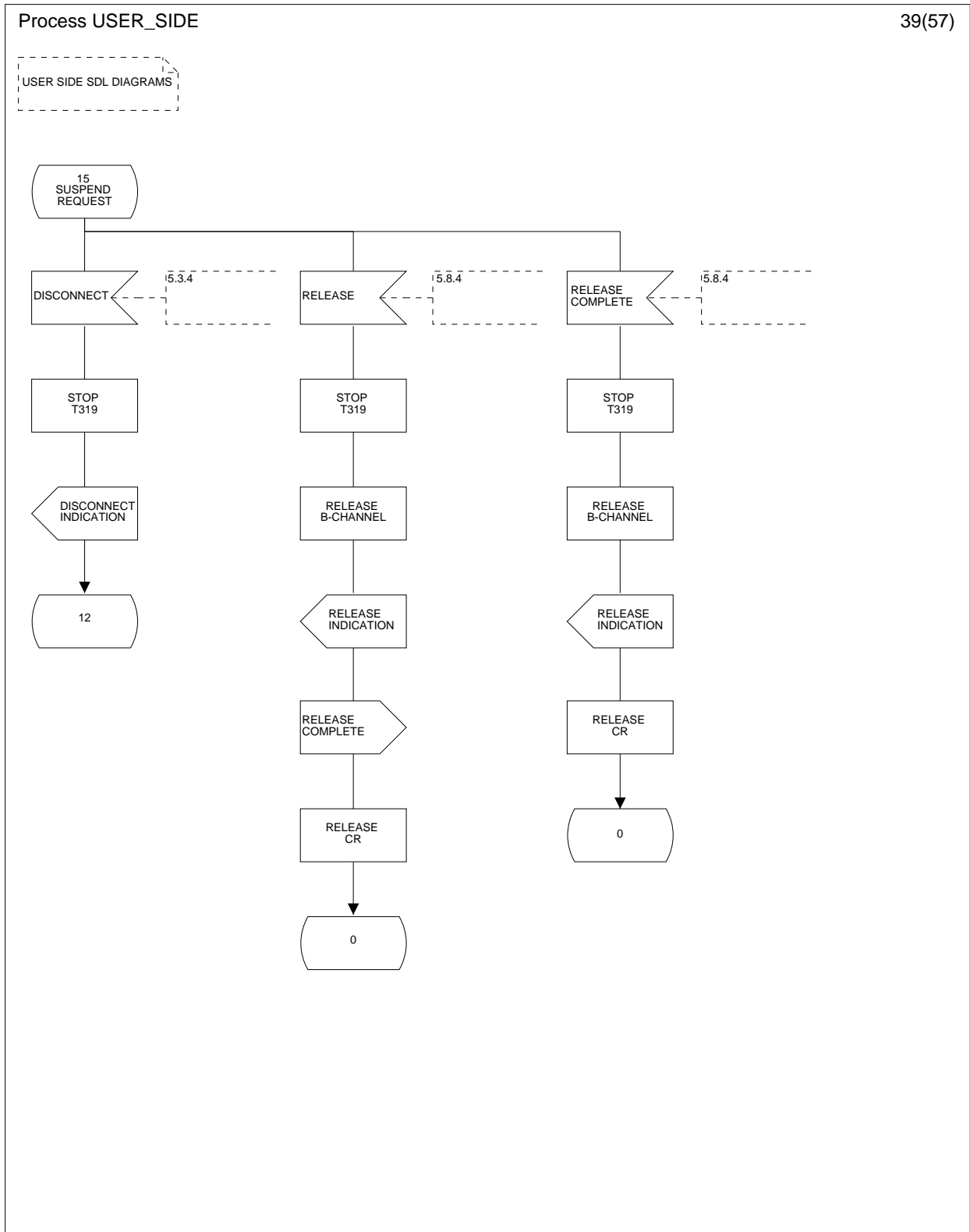

Figure 6 (sheet 39 of 57): User side SDL diagram

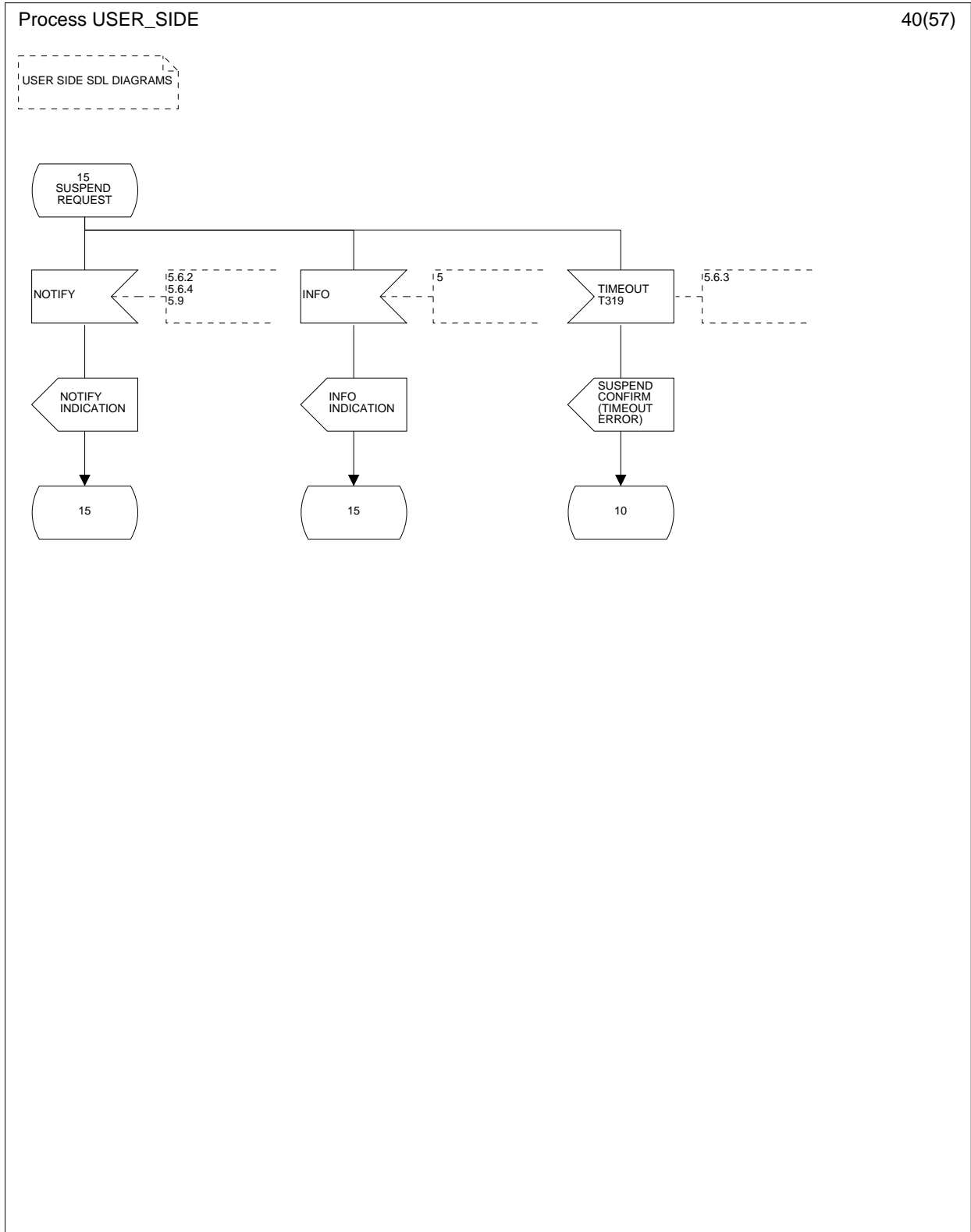

Figure 6 (sheet 40 of 57): User side SDL diagram

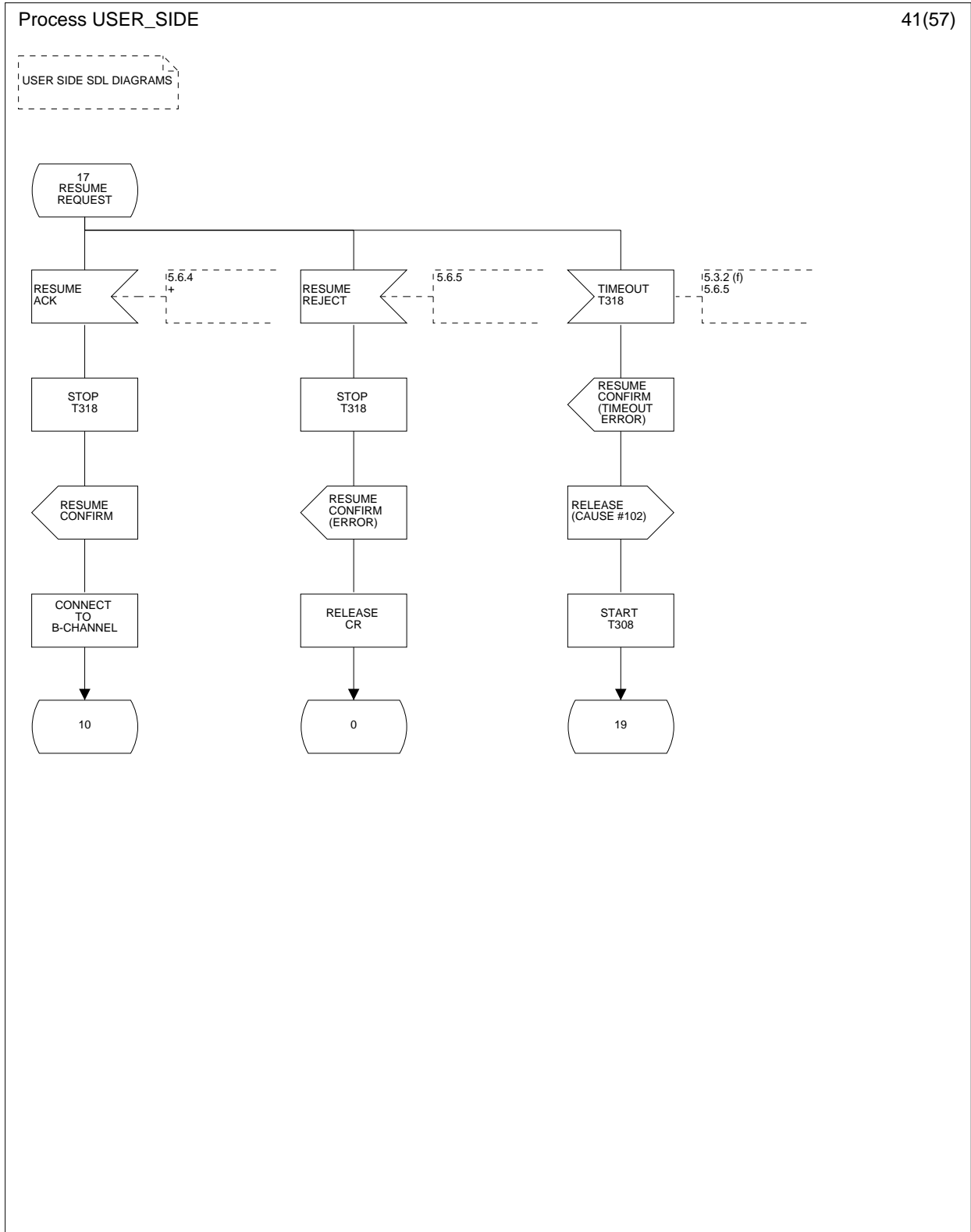

Figure 6 (sheet 41 of 57): User side SDL diagram

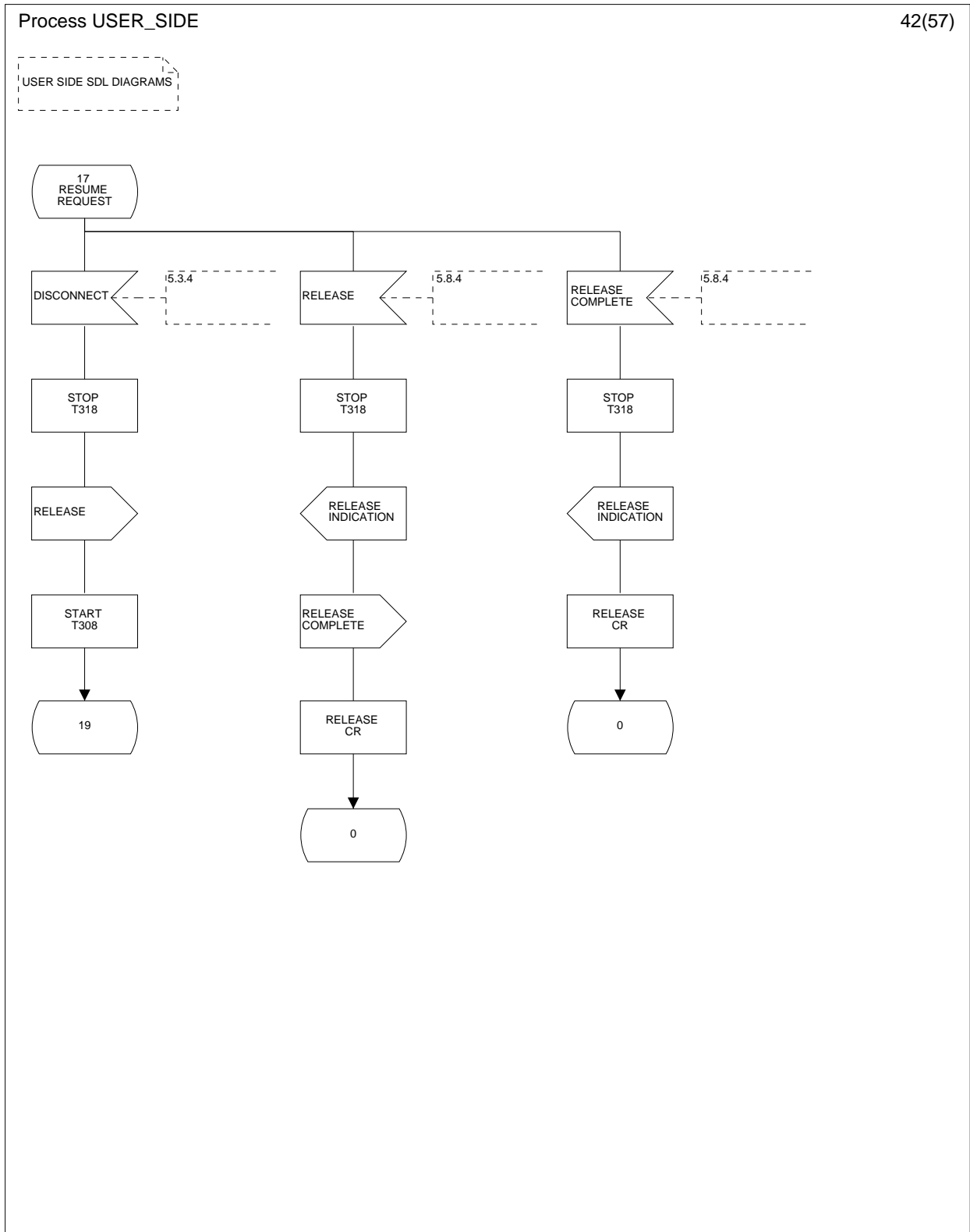

Figure 6 (sheet 42 of 57): User side SDL diagram

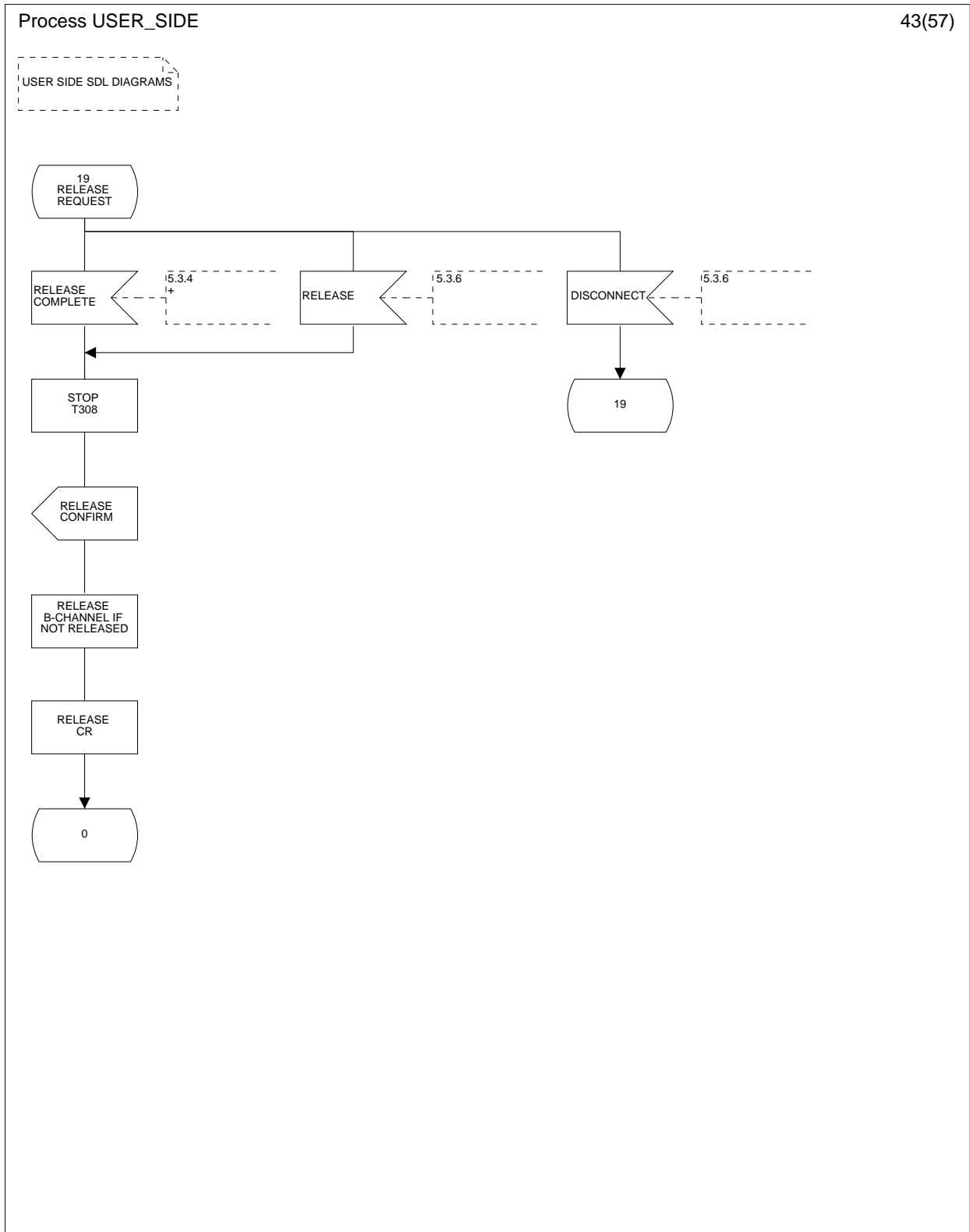

Figure 6 (sheet 43 of 57): User side SDL diagram



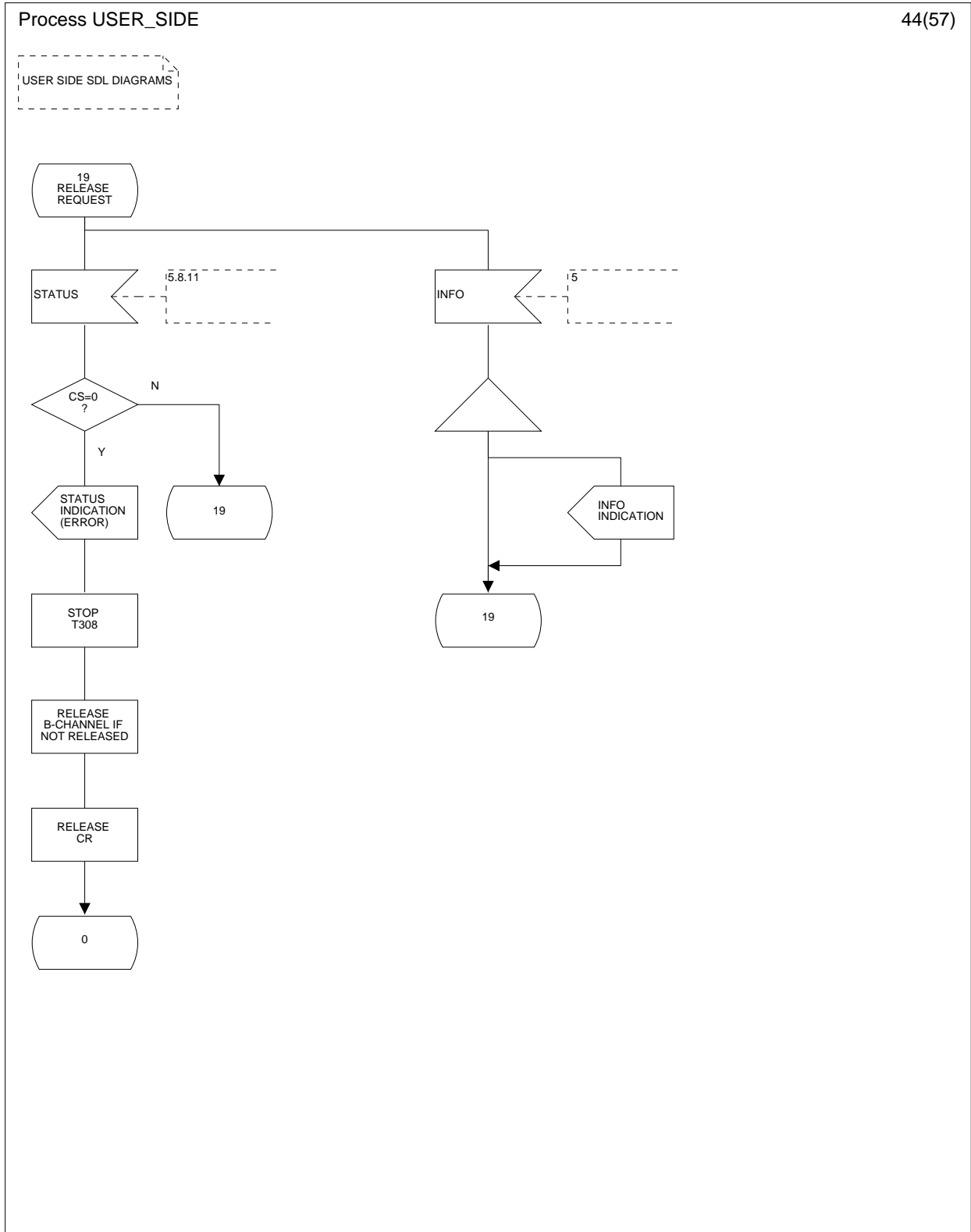

Figure 6 (sheet 44 of 57): User side SDL diagram

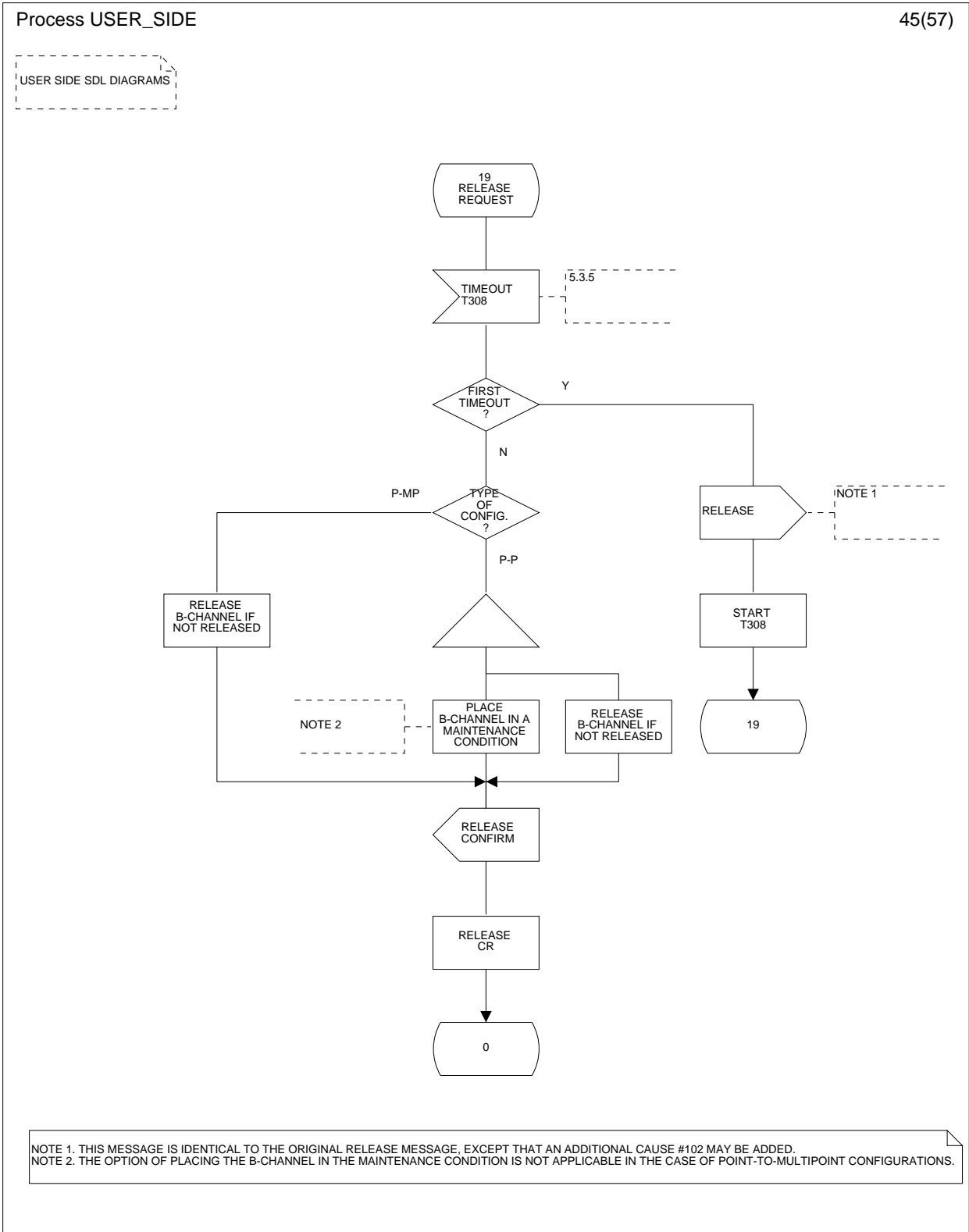

Figure 6 (sheet 45 of 57): User side SDL diagram

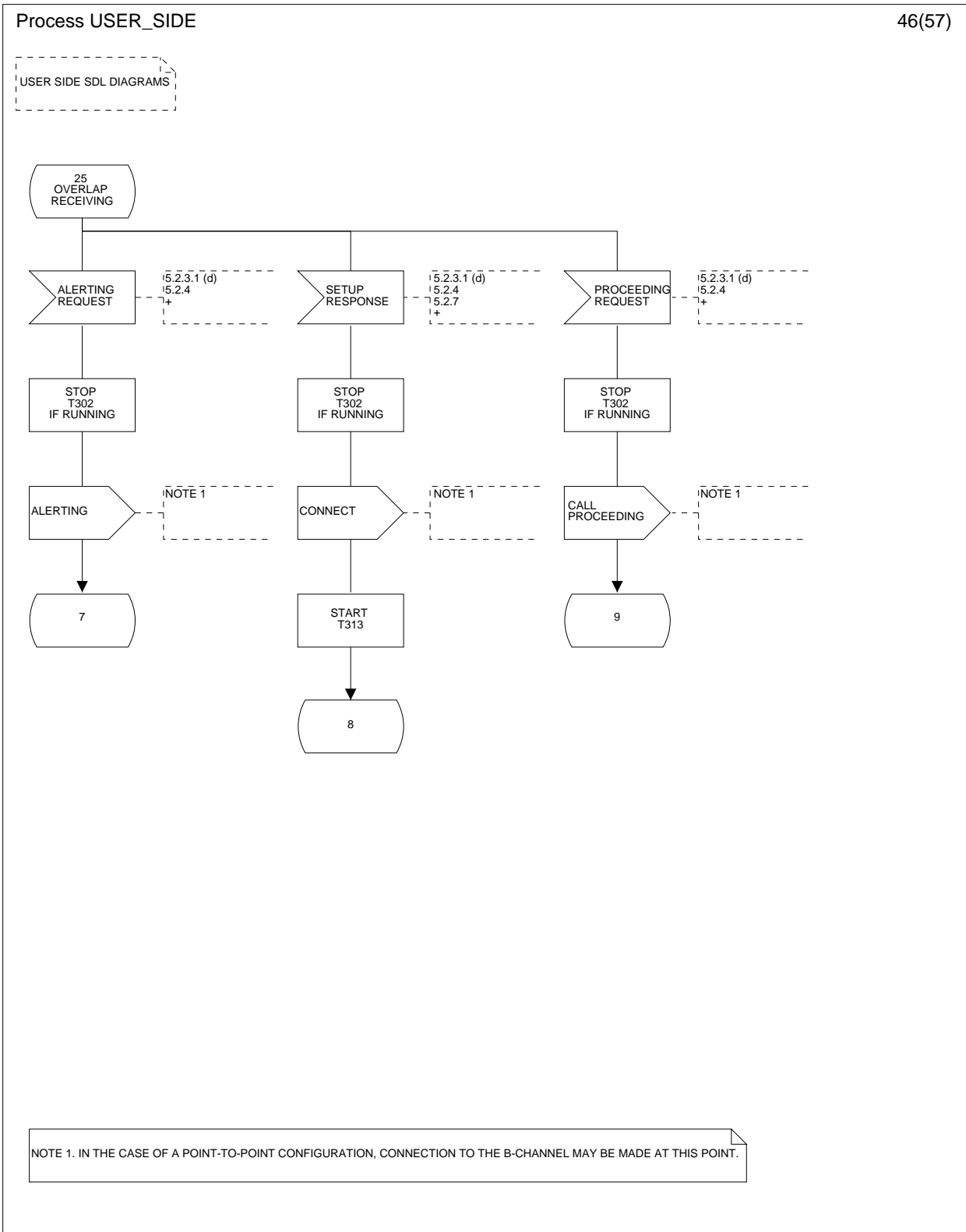

Figure 6 (sheet 46 of 57): User side SDL diagram

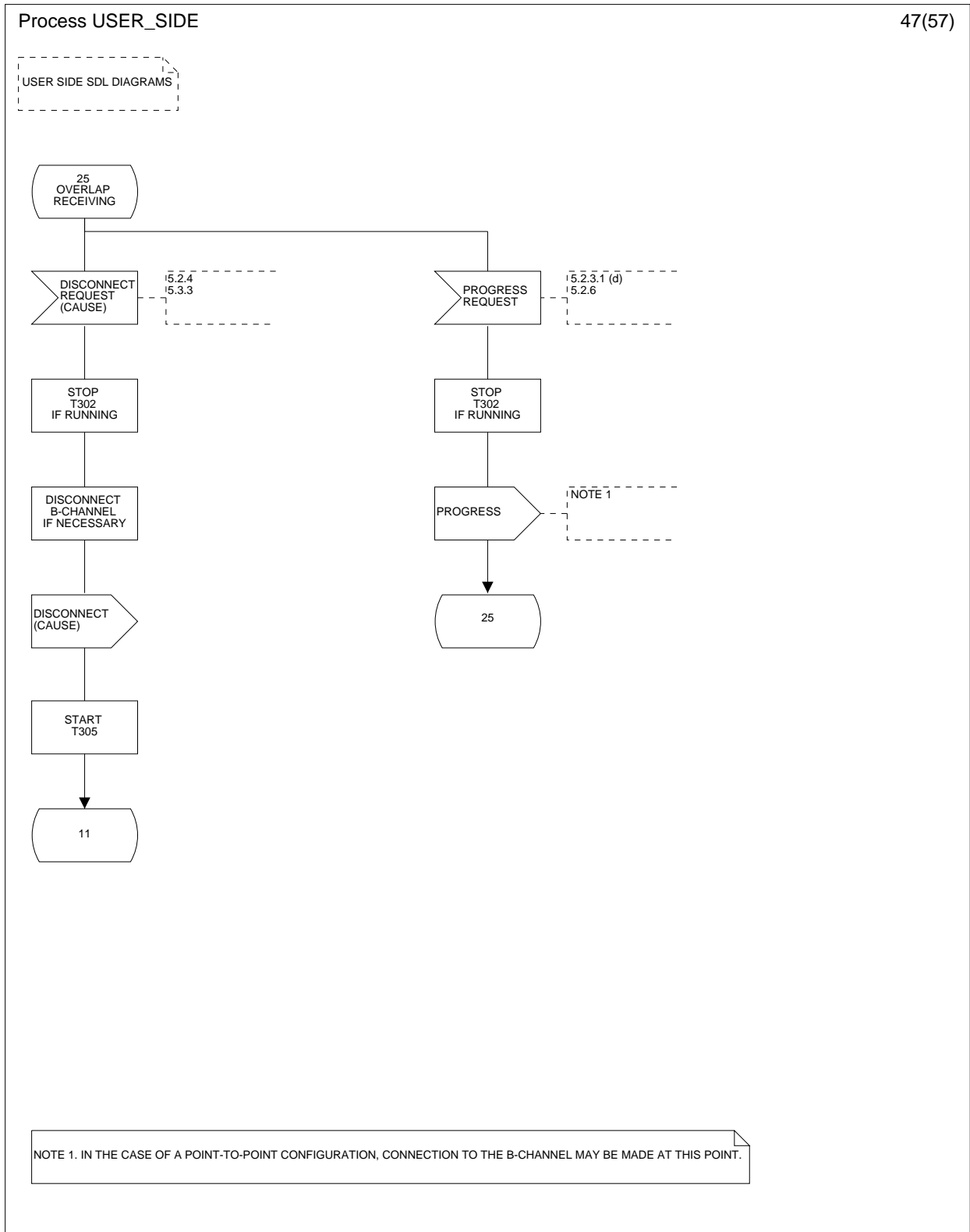

Figure 6 (sheet 47 of 57): User side SDL diagram

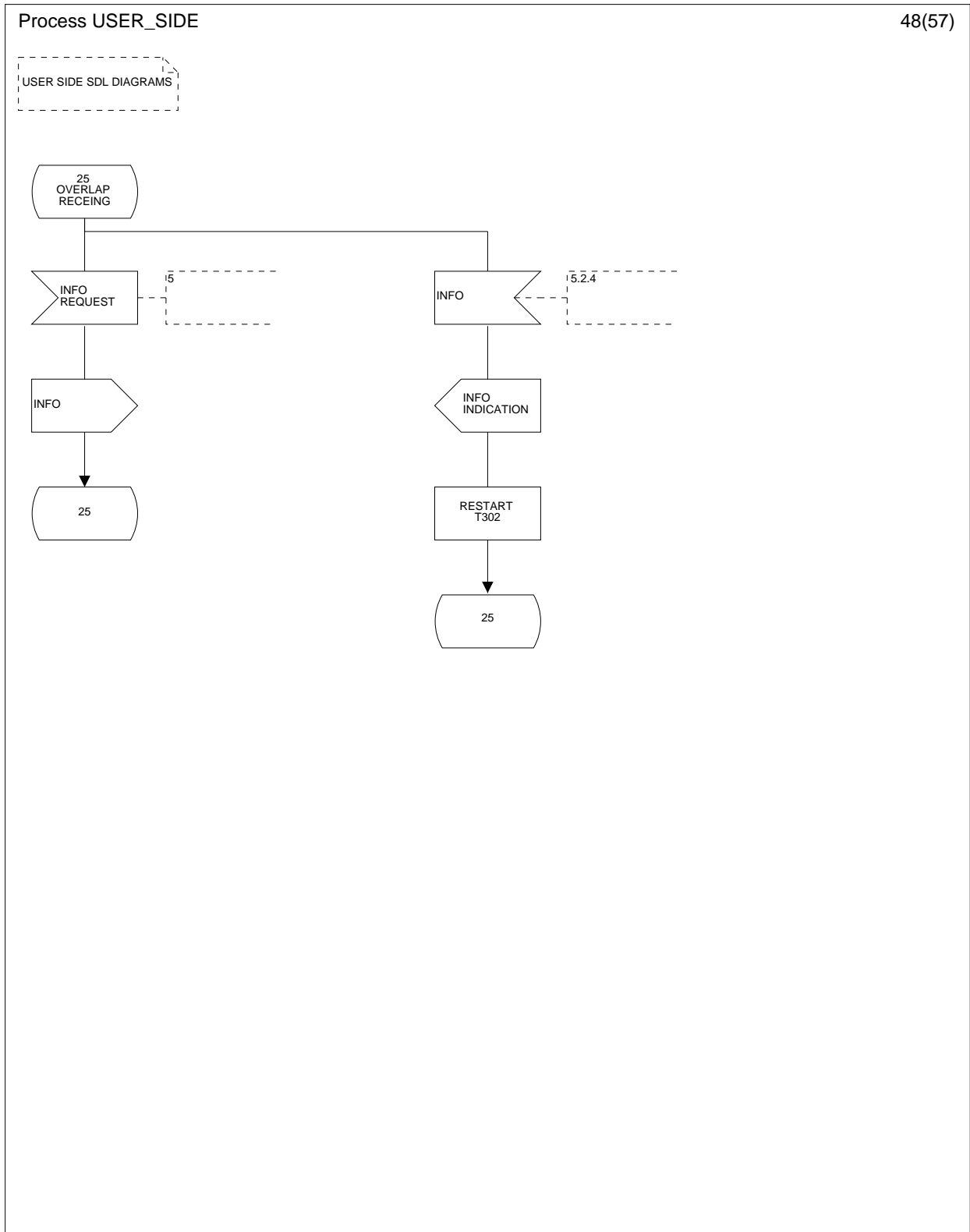

Figure 6 (sheet 48 of 57): User side SDL diagram

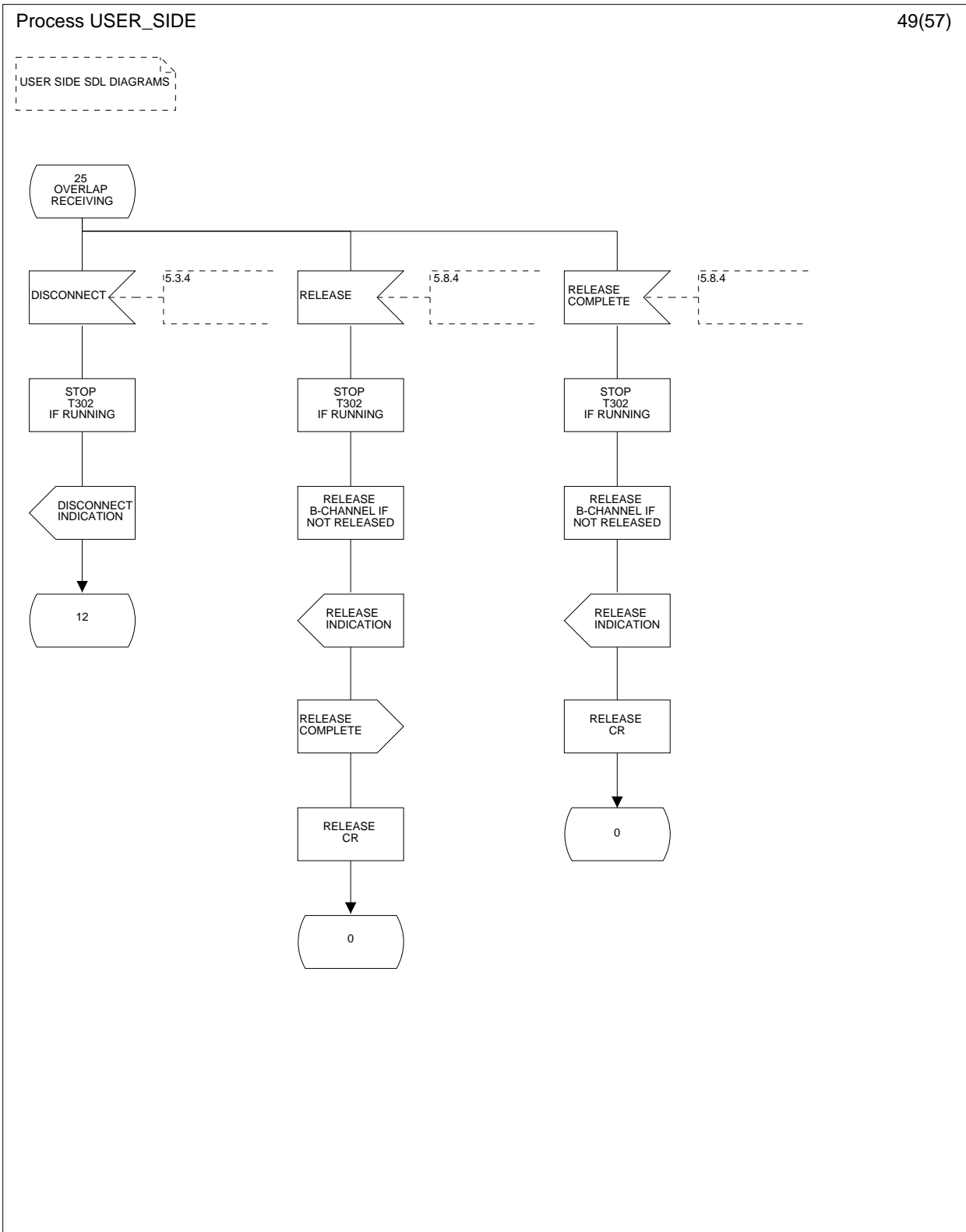

Figure 6 (sheet 49 of 57): User side SDL diagram

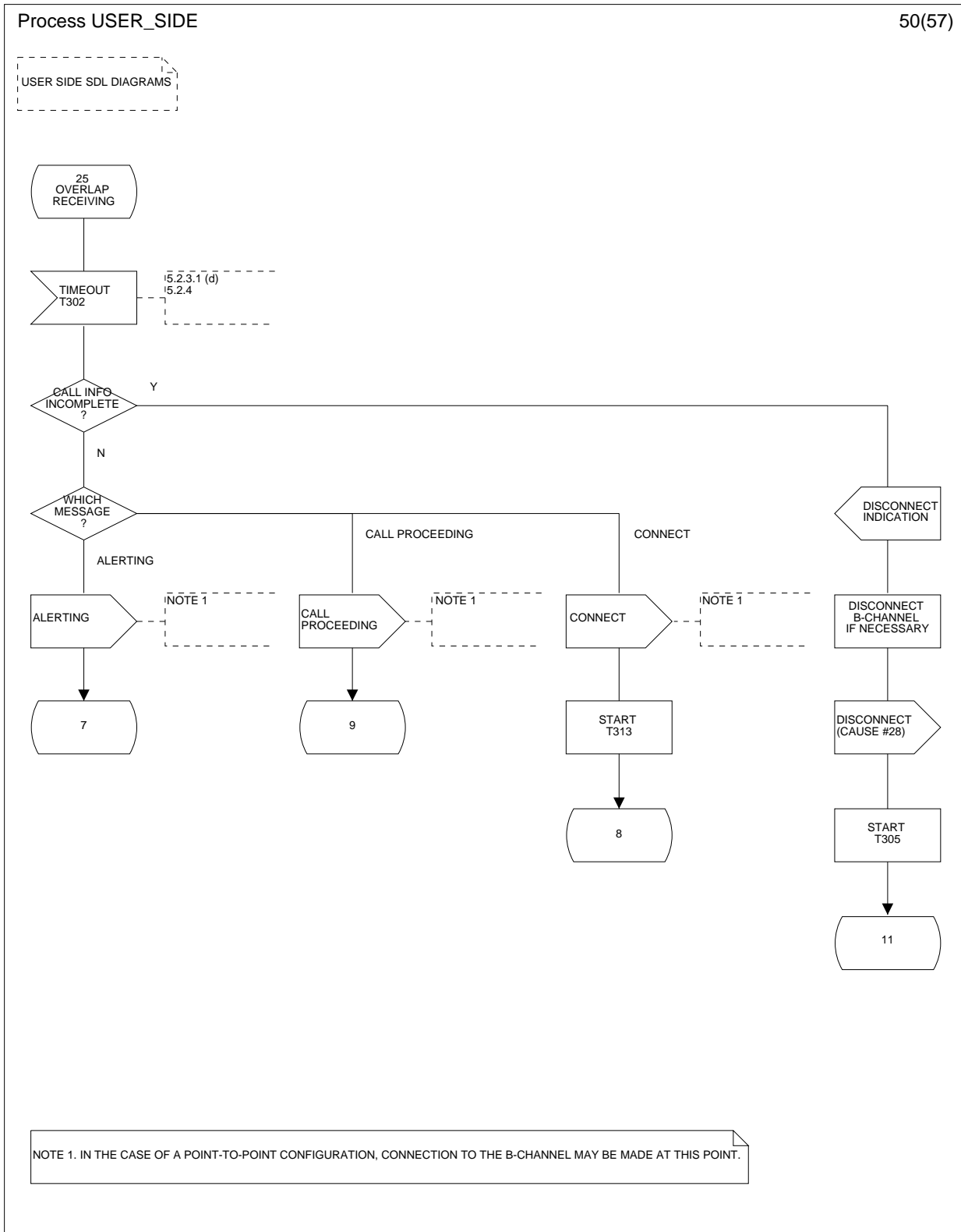

Figure 6 (sheet 50 of 57): User side SDL diagram

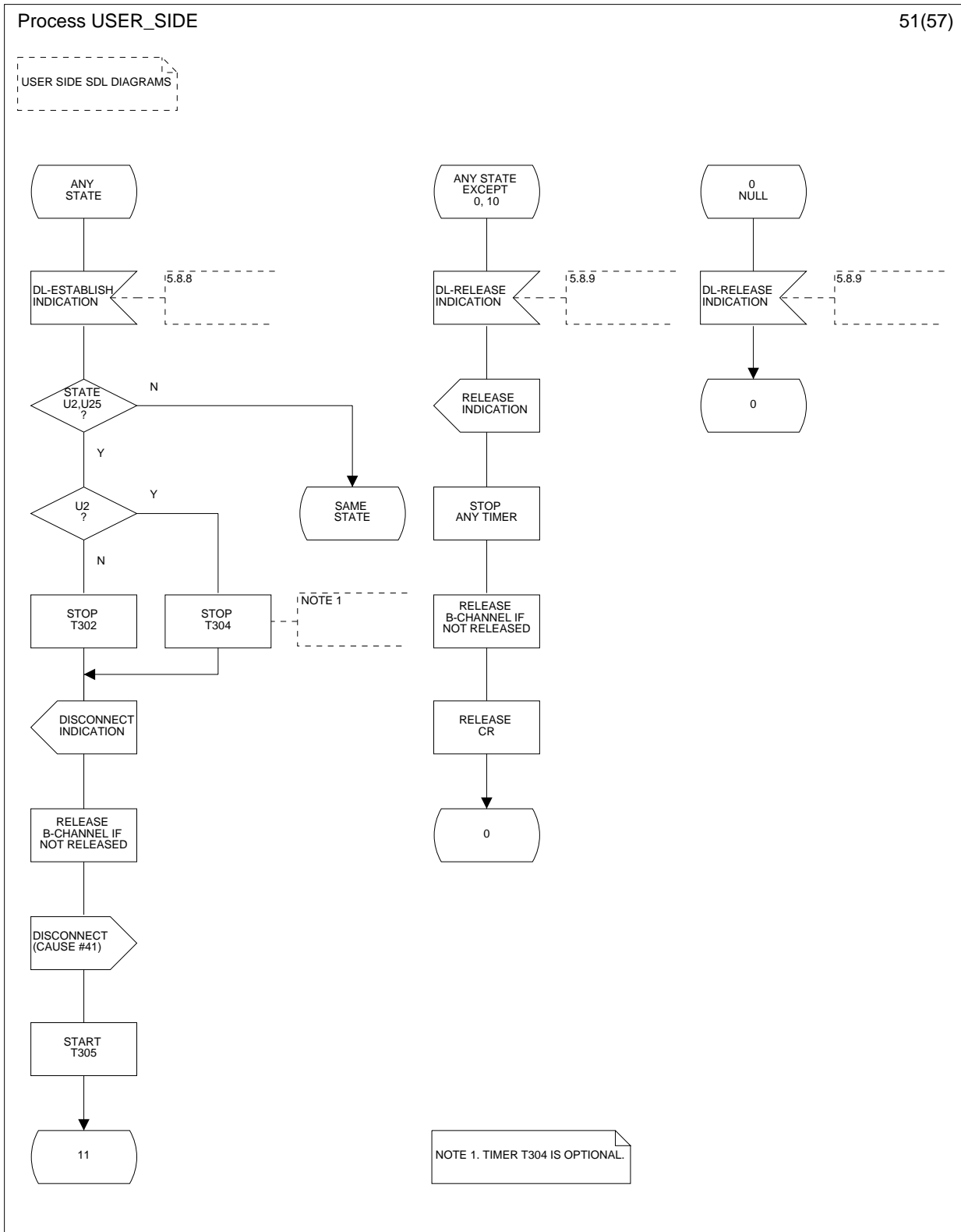

Figure 6 (sheet 51 of 57): User side SDL diagram



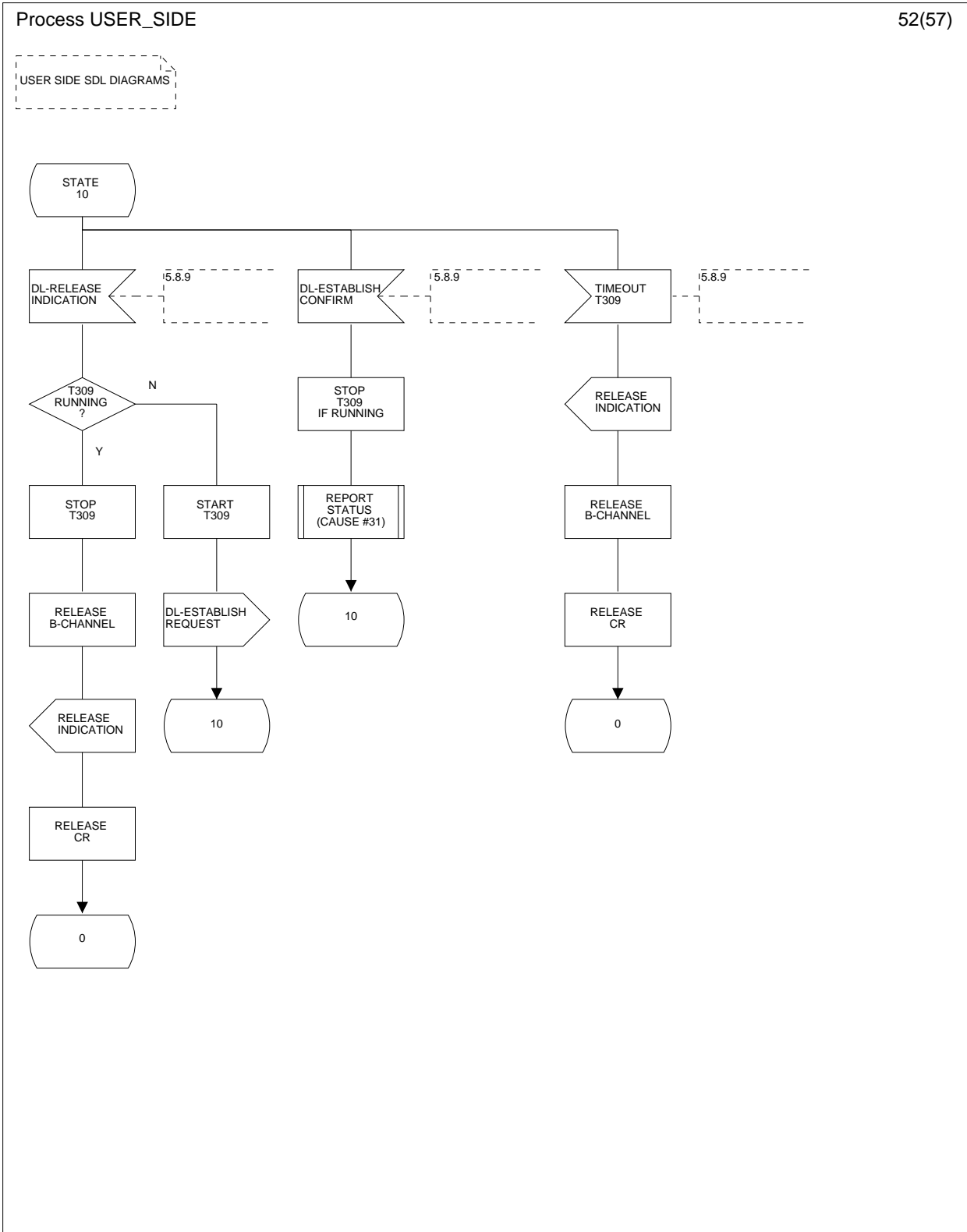

Figure 6 (sheet 52 of 57): User side SDL diagram

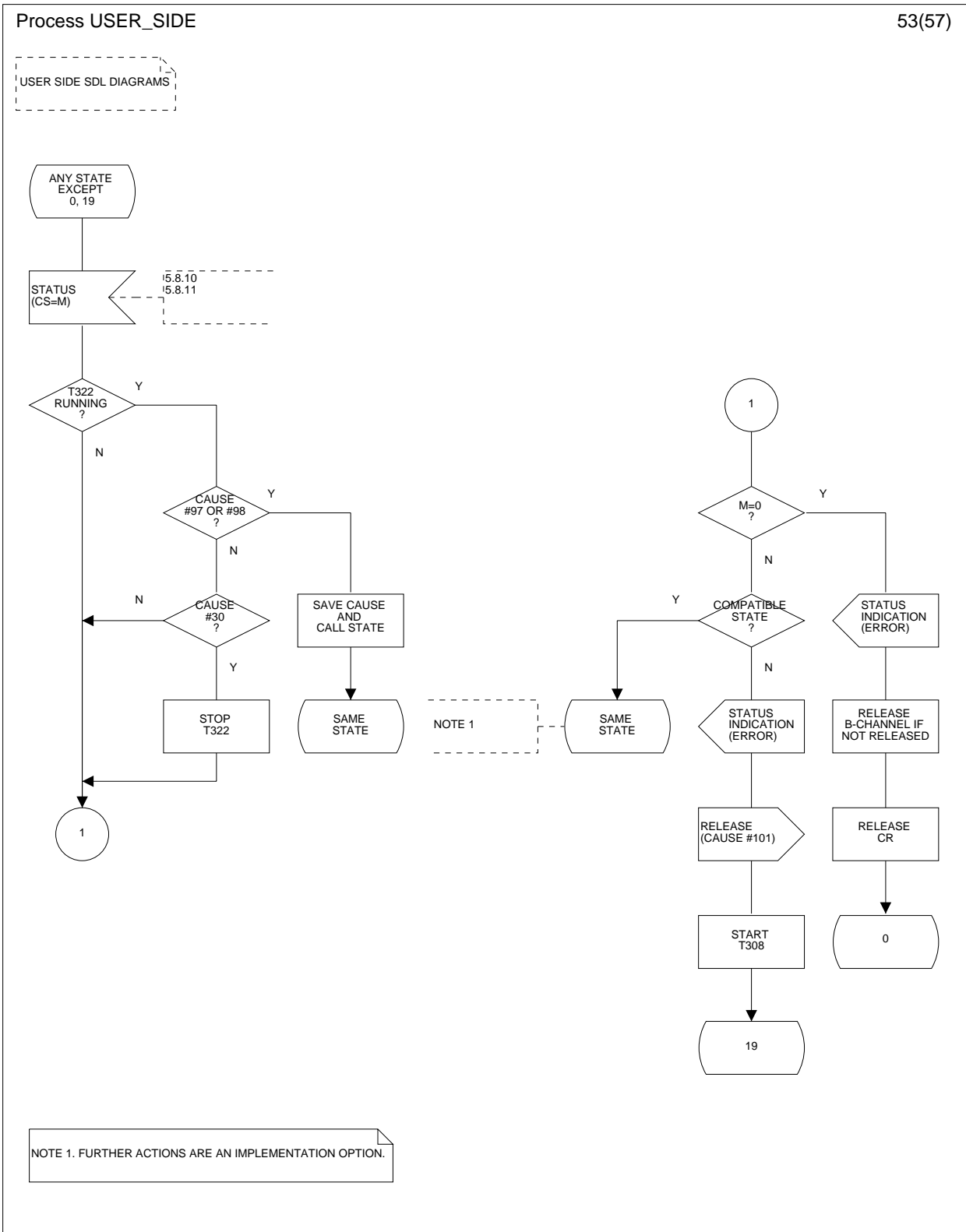

Figure 6 (sheet 53 of 57): User side SDL diagram

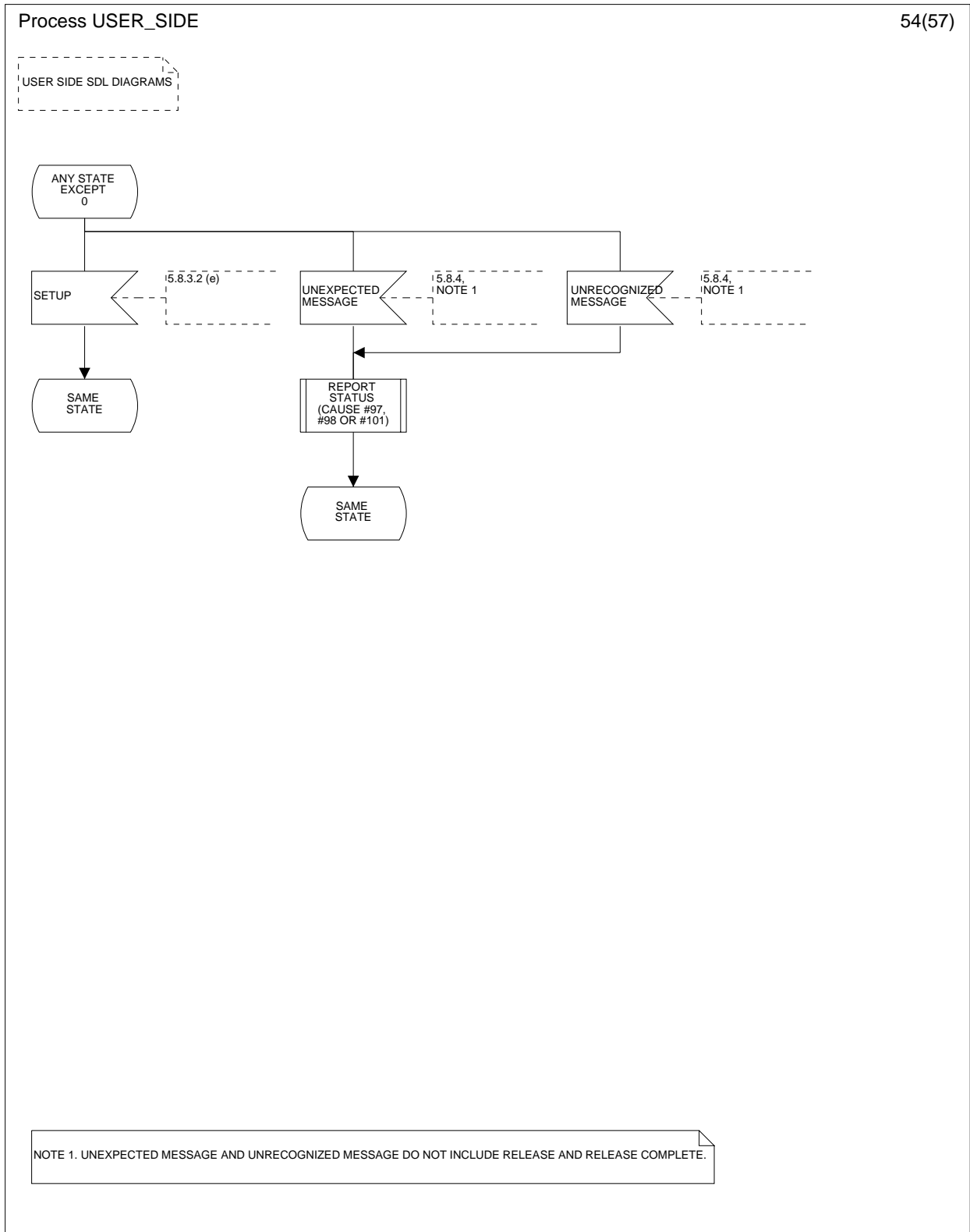

Figure 6 (sheet 54 of 57): User side SDL diagram

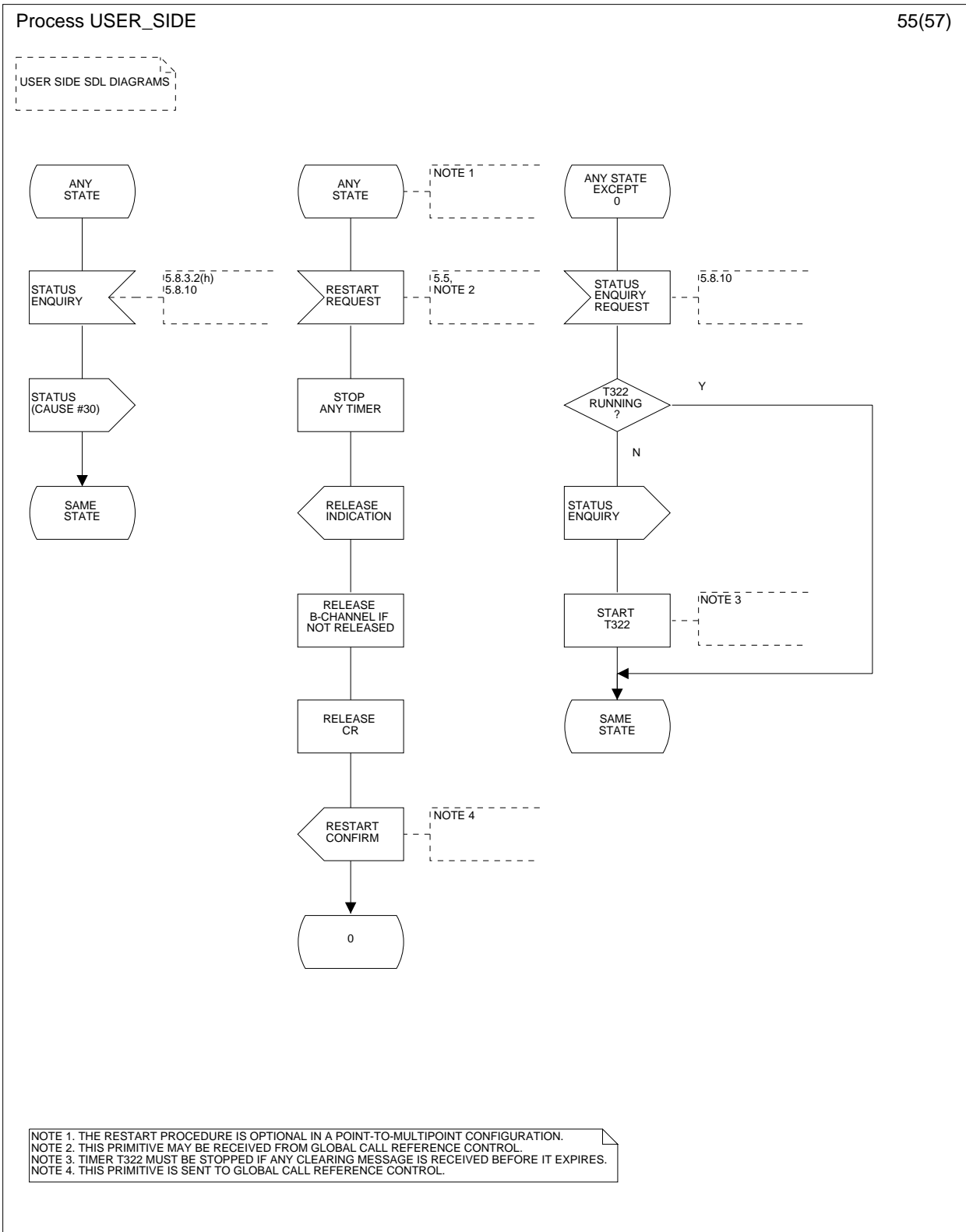

Figure 6 (sheet 55 of 57): User side SDL diagram

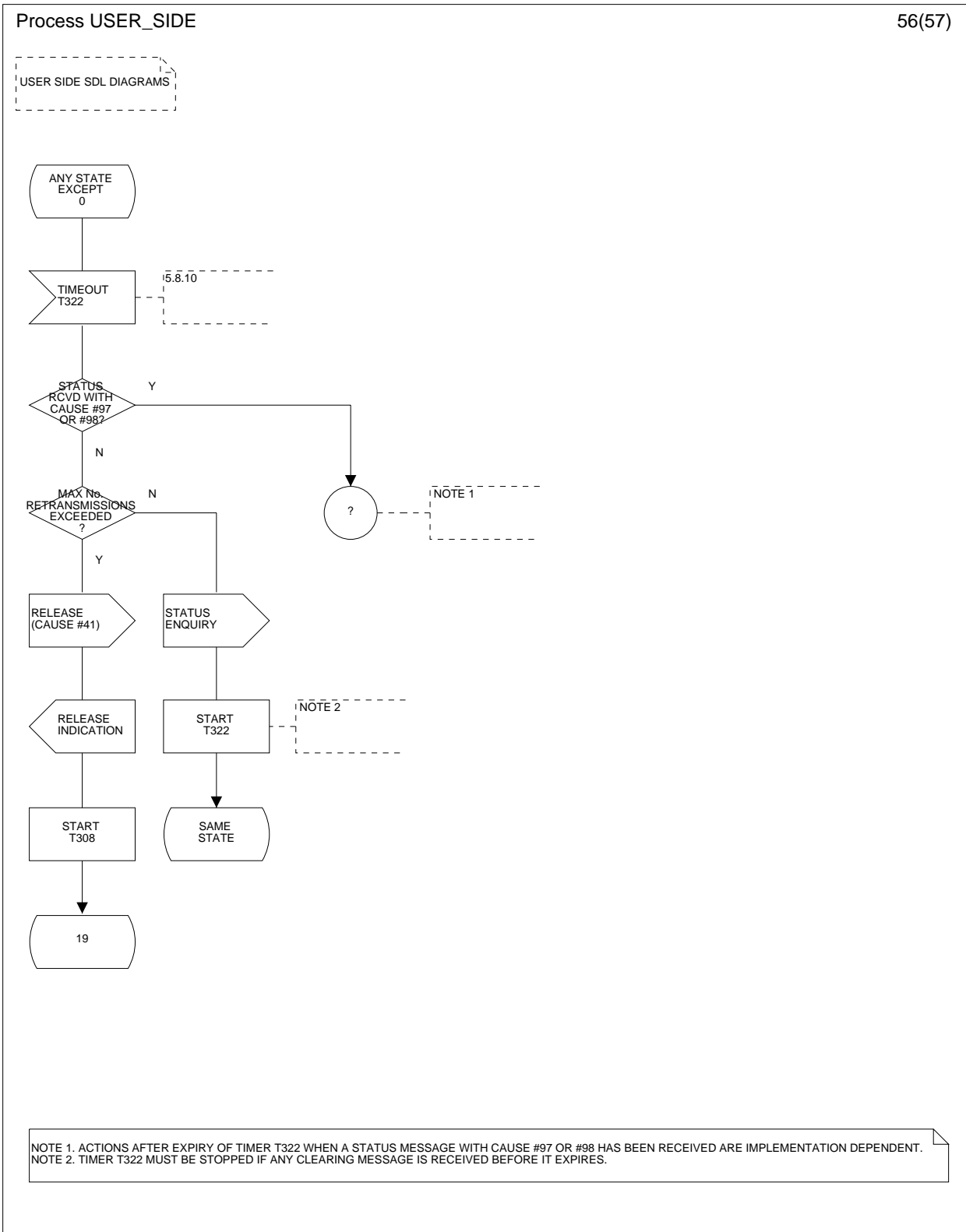

Figure 6 (sheet 56 of 57): User side SDL diagram

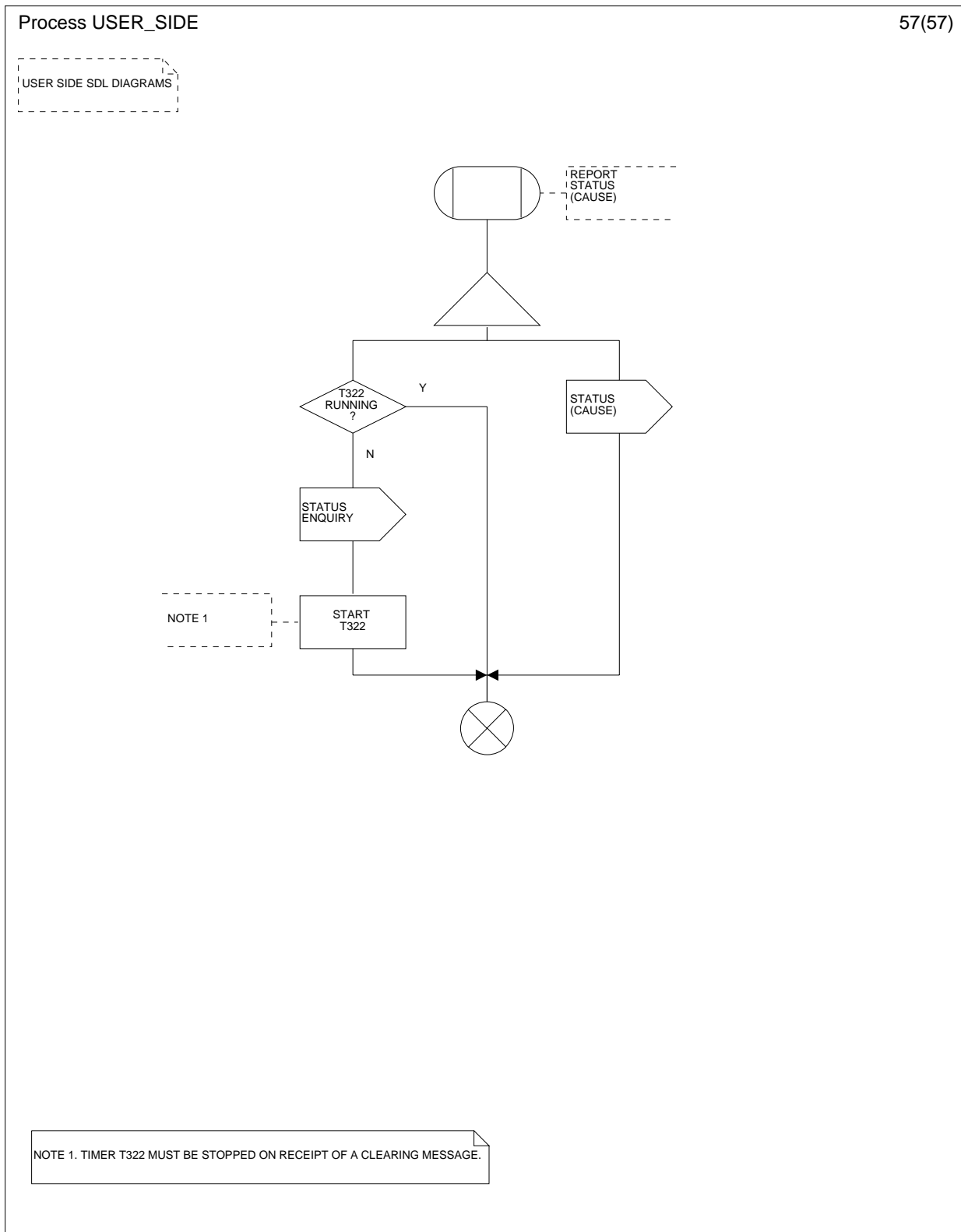

Figure 6 (sheet 57 of 57): User side SDL diagram

### 8.3 Restart SDL diagrams

This subclause shows detailed SDL diagrams for the global call reference to be applied to both user and network sides. Although these are drawn as user side only, the same diagrams can be applied to the network side by changing the direction of the input and output symbols.

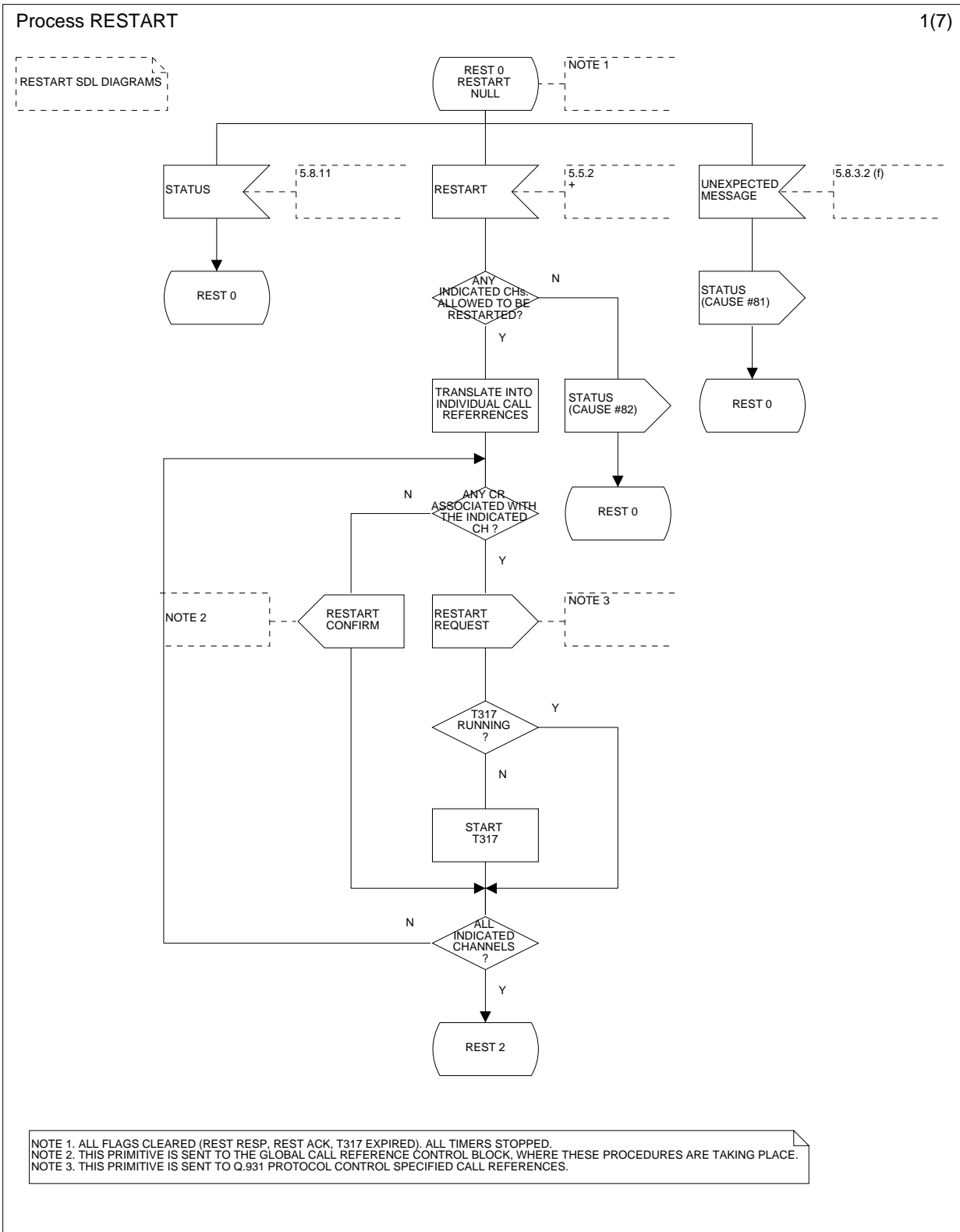
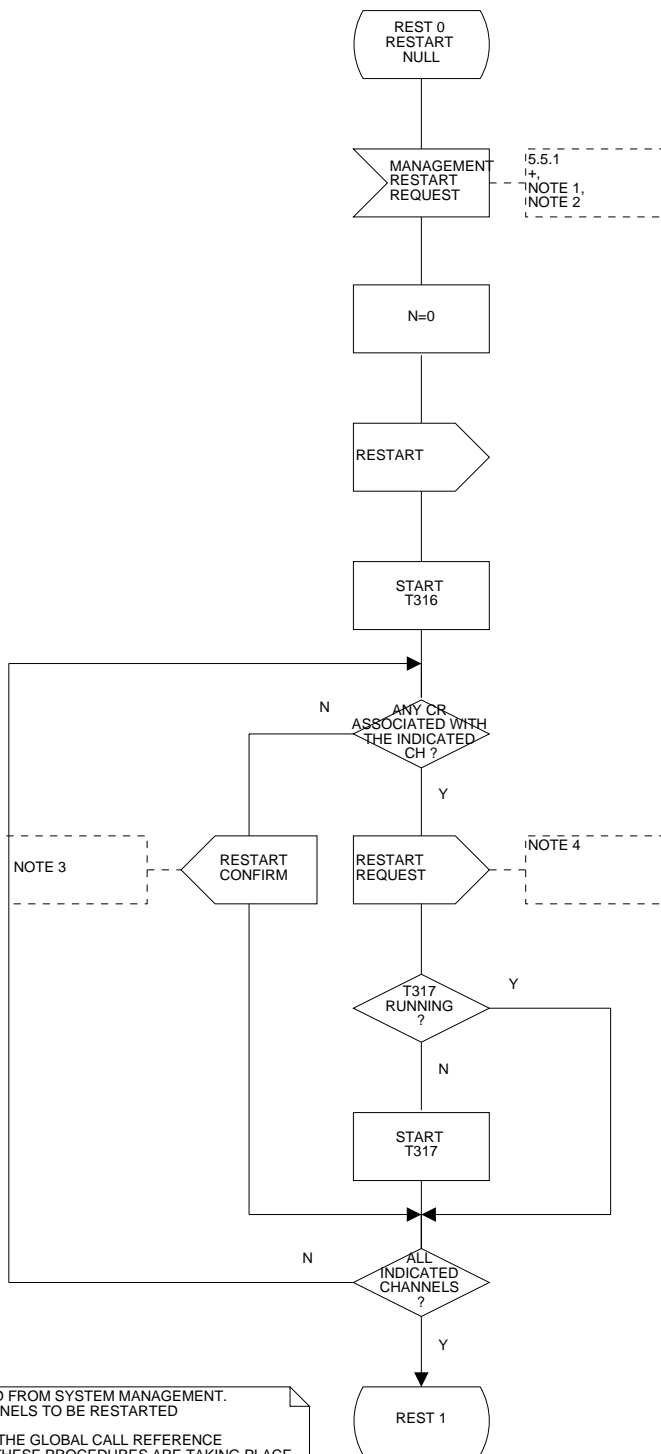

Figure 7 (sheet 1 of 7): Restart SDL diagrams

Process RESTART

2(7)

RESTART SDL DIAGRAMS



NOTE 1. THIS PRIMITIVE IS RECEIVED FROM SYSTEM MANAGEMENT.  
 NOTE 2. THE IDENTITY OF THE CHANNELS TO BE RESTARTED IS INCLUDED.  
 NOTE 3. THIS PRIMITIVE IS SENT TO THE GLOBAL CALL REFERENCE CONTROL BLOCK, WHERE THESE PROCEDURES ARE TAKING PLACE.  
 NOTE 4. THIS PRIMITIVE IS SENT TO Q.931 PROTOCOL CONTROL SPECIFIED CALL REFERENCES.

Figure 7 (sheet 2 of 7): Restart SDL diagrams



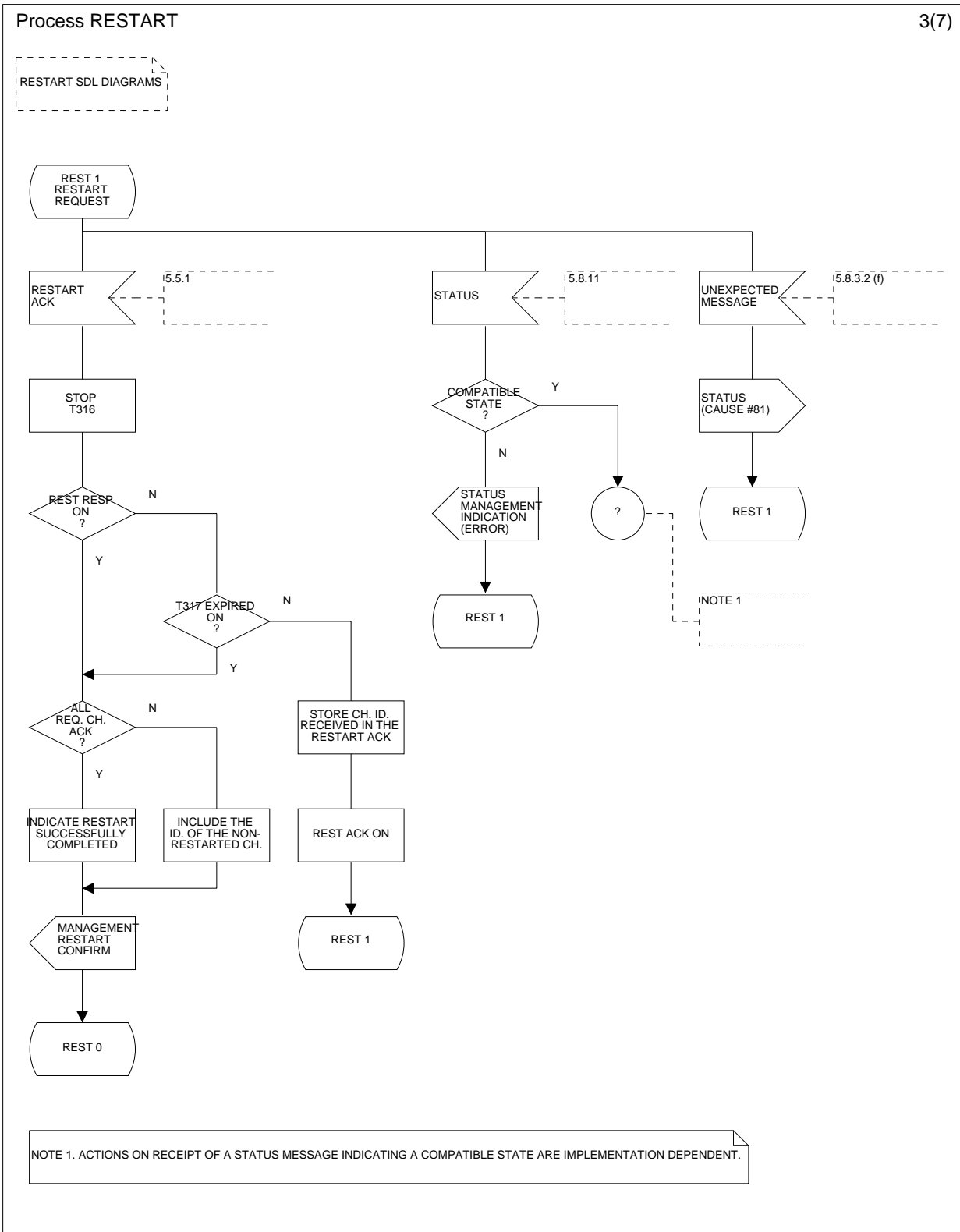

Figure 7 (sheet 3 of 7): Restart SDL diagrams

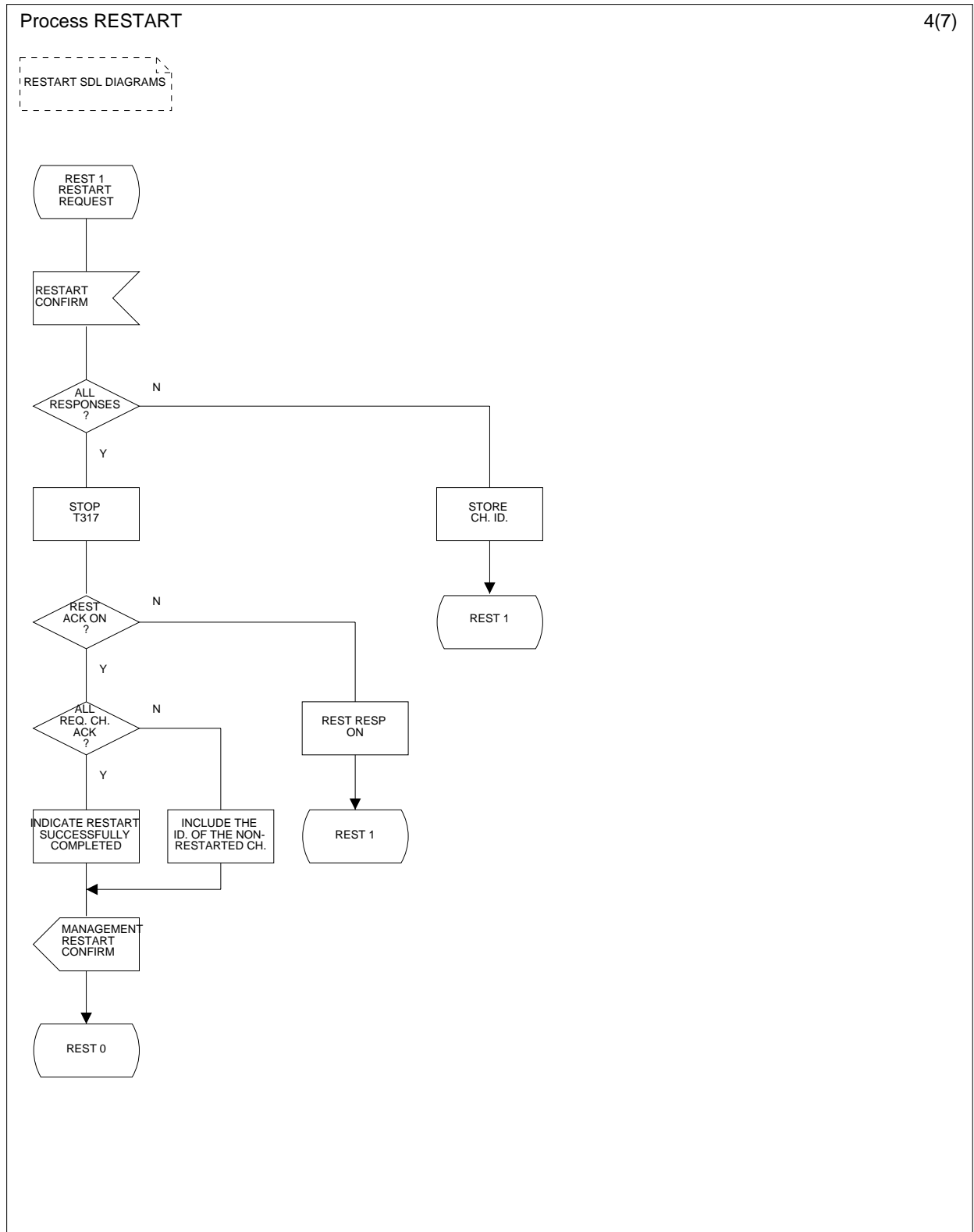
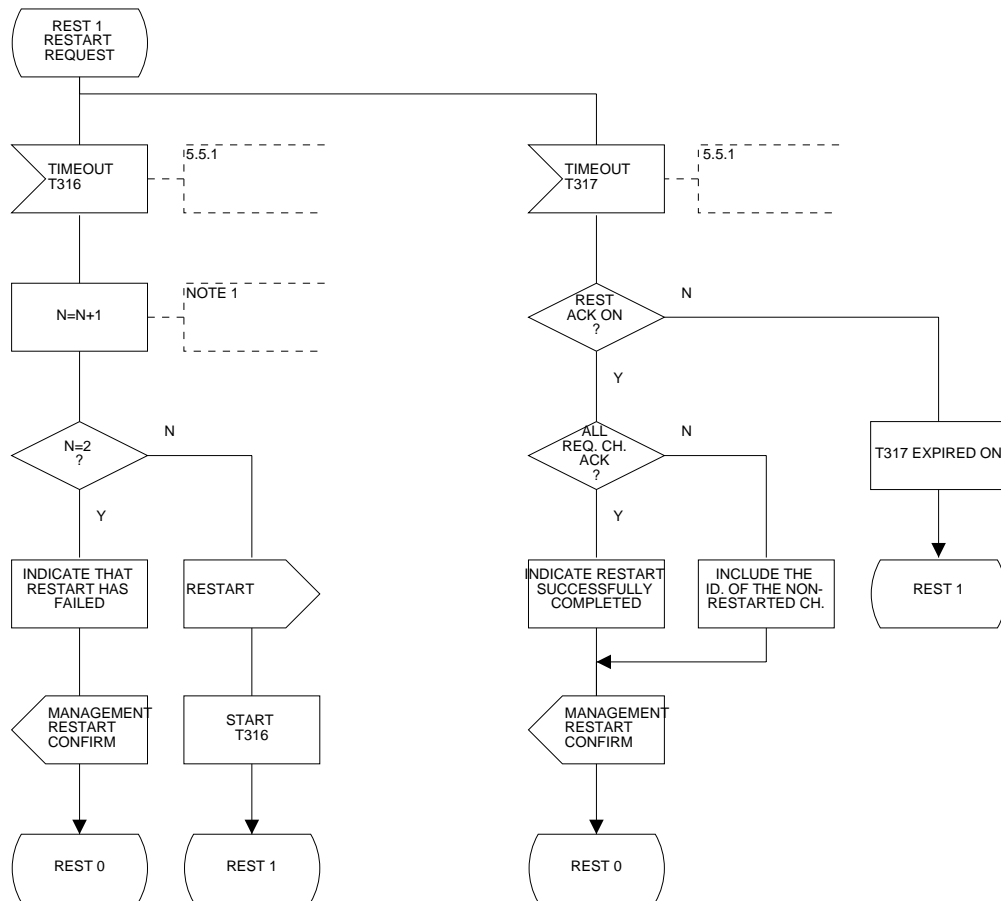

Figure 7 (sheet 4 of 7): Restart SDL diagrams

Process RESTART

5(7)

RESTART SDL DIAGRAMS



NOTE 1. DEFAULT MAXIMUM VALUE OF N IS 2.

Figure 7 (sheet 5 of 7): Restart SDL diagrams

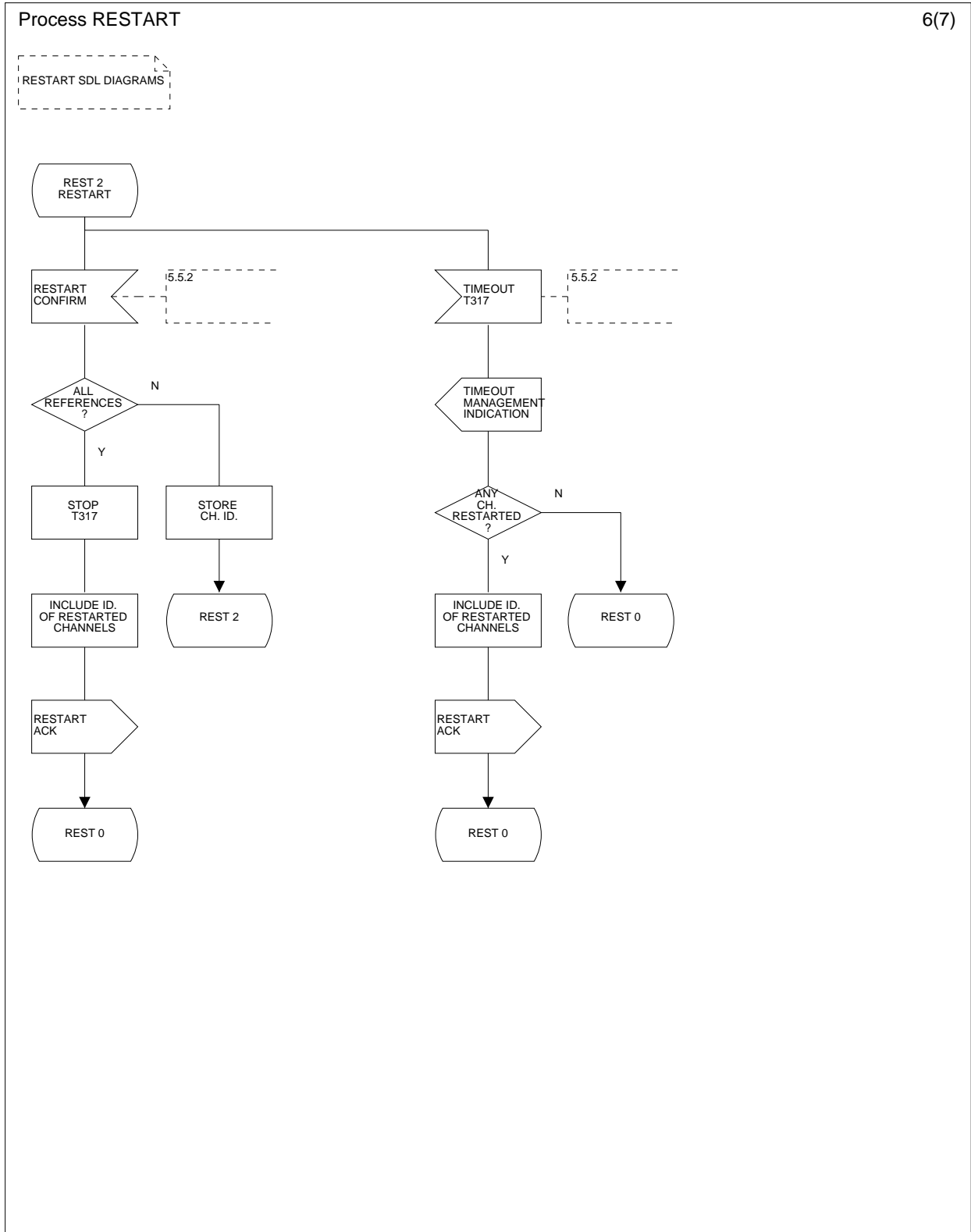

Figure 7 (sheet 6 of 7): Restart SDL diagrams

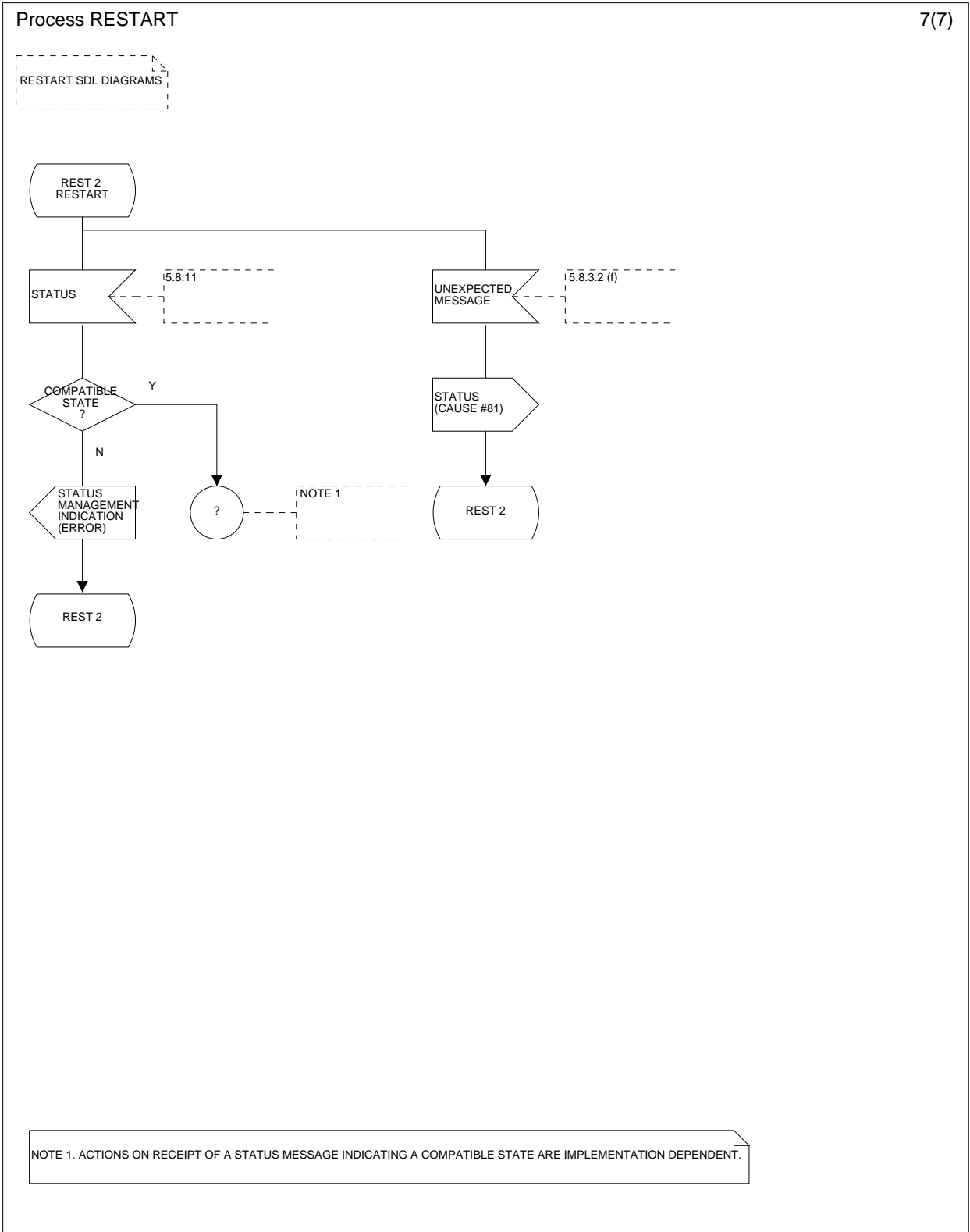

Figure 7 (sheet 7 of 7): Restart SDL diagrams

---

## Annex A (informative): Relevant differences to ETS 300 102-2

### A.1 Structural changes

The following structural changes have been made:

- a) the text part of the present document has been aligned with the PNE rules and, as such, an adequate scope has been added; new clauses have also been created concerning normative references, definitions, symbols and abbreviations;
- b) in subclause 5.4, some guidelines have been included explaining the basis on which the representation of SDL diagrams related to the management of timers in point-to-point and point-to-multipoint configurations for the network side of the interface is supported;
- c) a new subclause 6.4 has been created explaining the representation method adopted for the user side SDL diagrams;
- d) a new clause 7 has been created entirely dedicated to the handling of the SDL diagrams applicable for the restart procedure. It has been structured according to the same approach followed for the previous clauses related to the network side and user side (states related to the restart procedure, block diagram, list of primitives exchanged with system management and representation method). In this last subclause, some explanatory text is also provided concerning the flags which are used in these SDL diagrams;
- e) a new subclause 8.3 has been created in order to clearly separate the SDL diagrams related to the restart procedure from those related to the user side. The restart procedure diagrams are applicable, as in ETS 300 102-2, for both the network side and the user side of the interface;
- f) the lists of internal primitives between call control and protocol control in either the network side and the user side, which are represented in table 3 of subclause 5.3 and in table 6 of subclause 6.3, have been updated according to the new set of SDL diagrams. Some of them have been deleted because they are no longer used, while others related to the restart SDL diagrams have been added;
- g) the SDL diagrams have been entirely redrafted using a software tool and, as such, there has been a general rearrangement in the sequence of their appearance;
- h) furthermore, and regarding the redraft of the SDL diagrams, the following targets have been tried to be achieved:
  - 1) inclusion of all relevant cross-references to subclauses of ETS 300 403-1 [1] as a comment to all input symbols;
  - 2) inclusion of cause values which might be contained in the relevant ETS 300 403-1 [1] messages in the output symbols sent to the interface environment by either the network or by the user side;
  - 3) alignment of the user side SDL diagrams with those of the network side.

---

## A.2 Technical changes

The following technical changes have been made:

- a) throughout clause 8, the SDL diagrams have been aligned with the technical changes agreed for ETS 300 403-1 [1]. As an exception to this, the new note 2 in subclause 5.5 of ETS 300 403-1 [1] concerning the possible occurrence of collision of restart procedures initiated by either side of the interface has not been covered, due to the complexity of the representation;
- b) in the network side and in the user side SDL diagrams, the input symbols related to the primitives RELEASE REQUEST received from call control have been removed from all states, except N11 and U12, as there is no support in ETS 300 403-1 [1];
- c) in the network side and in the user side SDL diagrams, a new subroutine REPORT STATUS has been created which is invoked according to ETS 300 403-1 [1] subclause 5.8.4 whenever unexpected and unrecognized messages are received, and which allows the option of sending a STATUS ENQUIRY message or a STATUS message. As an exception to this principle, and as explained by an appropriate note in the diagrams, this subroutine is not represented in the SDL diagrams which handle the reception of unexpected DISCONNECT, PROGRESS or INFO messages by the global process when an incoming call is being offered in states Call received (N7), Connect request (N8), Incoming call proceeding (N9) and Overlap receiving (N25), as it increases the complexity of the representation. In these cases, although not precluded for implementations, only the transmission of the STATUS message is shown as the utilization of the status enquiry procedure does not provide any useful additional information to the network;
- d) on the network side, the SDL diagrams related to the management of timers both in the global process (states Call received (N7), Connect request (N8), Incoming call proceeding (N9) and Overlap receiving (N25)) and in individual processes (states Call received (7I), Connect request (8I), Incoming call proceeding (9I) and Overlap receiving (25I)), when an incoming call is being offered, have been rearranged according to the principles defined in subclause 5.4;
- e) on the network side, also as a consequence of the principle defined in subclause 5.4 related to the handling of timer T322 only in individual processes when an incoming call is being offered, a single diagram has been created valid for all the relevant states;
- f) on the network side, the input symbols STATUS and OTHER MESSAGES which were applicable for the individual processes have been deleted from the correspondent states, and have been replaced by two new diagrams valid for all states;
- g) on the network side, a new diagram representing the handling of the expiry of timer T301 in state Call received (N7) has replaced the existing one. This new diagram is similar to the one which already represented the handling of the expiry of timer T310 in state Incoming call proceeding (N9), as it is supported by subclause 5.2.5.4 of ETS 300 403-1 [1];
- h) on the user side, all references to timers T301 and T310 have been deleted due to the removal of annex D from ETS 300 403-1 [1].

---

## History

<b>Document history</b>		
Edition 1	November 1995	Publication as ETS 300 403-2
V1.3.1	December 1999	Public Enquiry PE 200016: 1999-12-22 to 2000-04-21
V1.3.1	August 2000	Vote V 20001027: 2000-08-28 to 2000-10-27