

Final draft **ETSI EN 300 392-7** V3.0.3 (2008-04)

European Standard (Telecommunications series)

**Terrestrial Trunked Radio (TETRA);
Voice plus Data (V+D);
Part 7: Security**

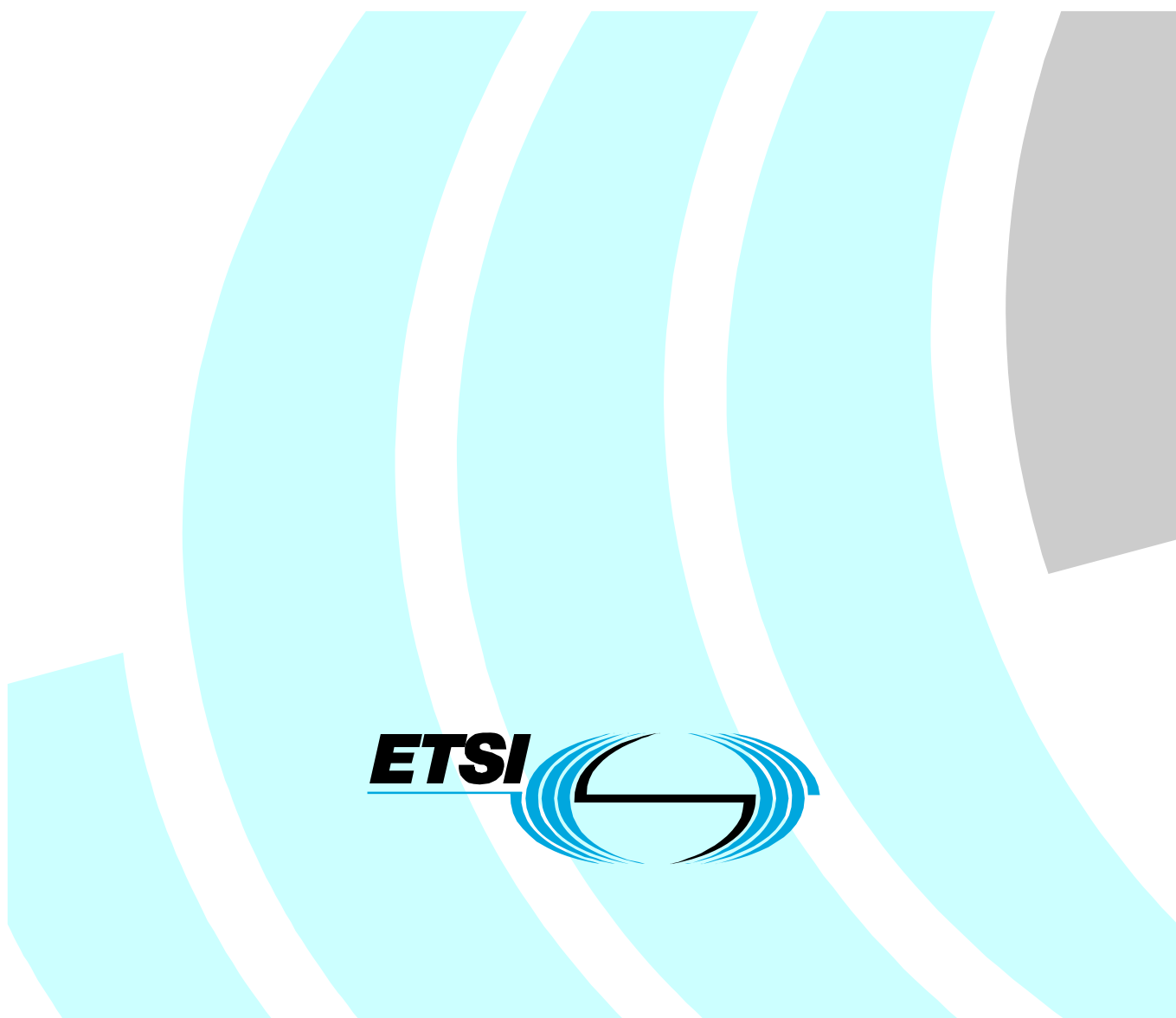

Reference

REN/TETRA-06173

Keywords

security, TETRA, V+D

ETSI

650 Route des Lucioles
F-06921 Sophia Antipolis Cedex - FRANCE

Tel.: +33 4 92 94 42 00 Fax: +33 4 93 65 47 16

Siret N° 348 623 562 00017 - NAF 742 C
Association à but non lucratif enregistrée à la
Sous-Préfecture de Grasse (06) N° 7803/88

Important notice

Individual copies of the present document can be downloaded from:

<http://www.etsi.org>

The present document may be made available in more than one electronic version or in print. In any case of existing or perceived difference in contents between such versions, the reference version is the Portable Document Format (PDF). In case of dispute, the reference shall be the printing on ETSI printers of the PDF version kept on a specific network drive within ETSI Secretariat.

Users of the present document should be aware that the document may be subject to revision or change of status. Information on the current status of this and other ETSI documents is available at

<http://portal.etsi.org/tb/status/status.asp>

If you find errors in the present document, please send your comment to one of the following services:

http://portal.etsi.org/chaicor/ETSI_support.asp

Copyright Notification

No part may be reproduced except as authorized by written permission.
The copyright and the foregoing restriction extend to reproduction in all media.

© European Telecommunications Standards Institute 2008.
All rights reserved.

DECT™, PLUGTESTS™, UMTS™, TIPHON™, the TIPHON logo and the ETSI logo are Trade Marks of ETSI registered for the benefit of its Members.

3GPP™ is a Trade Mark of ETSI registered for the benefit of its Members and of the 3GPP Organizational Partners.

Contents

Intellectual Property Rights	9
Foreword.....	9
1 Scope	11
2 References	11
2.1 Normative references	12
2.2 Informative references.....	12
3 Definitions and abbreviations.....	12
3.1 Definitions	12
3.2 Abbreviations	15
4 Air Interface authentication and key management mechanisms	16
4.0 Security classes	17
4.1 Air interface authentication mechanisms	17
4.1.1 Overview	17
4.1.2 Authentication of an MS.....	18
4.1.3 Authentication of the infrastructure	18
4.1.4 Mutual authentication of MS and infrastructure	19
4.1.5 The authentication key.....	21
4.1.6 Equipment authentication	21
4.2 Air Interface key management mechanisms.....	22
4.2.1 The DCK.....	22
4.2.2 The GCK.....	23
4.2.3 The CCK.....	24
4.2.4 The SCK	25
4.2.4.1 SCK association for DMO use	26
4.2.4.1.1 DMO SCK subset grouping.....	26
4.2.5 The GSKO	29
4.2.5.1 SCK distribution to groups with OTAR.....	29
4.2.5.2 GCK distribution to groups with OTAR	29
4.2.5.3 Rules for MS response to group key distribution	30
4.2.6 Encrypted Short Identity (ESI) mechanism	30
4.2.7 Encryption Cipher Key	31
4.2.8 Summary of AI key management mechanisms.....	31
4.3 Service description and primitives	32
4.3.1 Authentication primitives	32
4.3.2 SCK transfer primitives	33
4.3.3 GCK transfer primitives.....	34
4.3.4 GSKO transfer primitives	35
4.4 Authentication protocol.....	35
4.4.1 Authentication state transitions.....	35
4.4.2 Authentication protocol sequences and operations	38
4.4.2.1 MSCs for authentication	39
4.4.2.2 MSCs for authentication Type-3 element	45
4.4.2.3 Control of authentication timer T354 at MS	48
4.5 OTAR protocols	49
4.5.1 CCK delivery - protocol functions.....	49
4.5.1.1 SwMI-initiated CCK provision	49
4.5.1.2 MS-initiated CCK provision with U-OTAR CCK demand.....	51
4.5.1.3 MS-initiated CCK provision with announced cell reselection	52
4.5.2 OTAR protocol functions - SCK	52
4.5.2.1 MS requests provision of SCK(s).....	53
4.5.2.2 SwMI provides SCK(s) to individual MS	54
4.5.2.3 SwMI provides SCK(s) to group of MSs	56
4.5.2.4 SwMI rejects provision of SCK	58
4.5.3 OTAR protocol functions - GCK.....	58
4.5.3.1 MS requests provision of GCK	58

4.5.3.2	SwMI provides GCK to an individual MS.....	61
4.5.3.3	SwMI provides GCK to a group of MSs.....	63
4.5.3.4	SwMI rejects provision of GCK.....	65
4.5.4	Cipher key association to group address.....	65
4.5.4.1	SCK association for DMO.....	66
4.5.4.2	GCK association.....	69
4.5.5	Notification of key change over the air.....	71
4.5.5.1	Change of DCK.....	73
4.5.5.2	Change of CCK.....	73
4.5.5.3	Change of GCK.....	73
4.5.5.4	Change of SCK for TMO.....	73
4.5.5.5	Change of SCK for DMO.....	74
4.5.5.6	Synchronization of Cipher Key Change.....	74
4.5.6	Security class change.....	74
4.5.6.1	Change of security class to security class 1.....	75
4.5.6.2	Change of security class to security class 2.....	75
4.5.6.3	Change of security class to security class 3.....	75
4.5.6.4	Change of security class to security class 3 with GCK.....	76
4.5.7	Notification of key in use.....	76
4.5.8	Notification of GCK Activation/Deactivation.....	76
4.5.9	Deletion of SCK, GCK and GSKO.....	76
4.5.10	Air Interface Key Status Enquiry.....	78
4.5.11	Crypto management group.....	80
4.5.12	OTAR retry mechanism.....	81
4.5.13	OTAR protocol functions – GSKO.....	81
4.5.13.1	MS requests provision of GSKO.....	81
4.5.13.2	SwMI provides GSKO to an MS.....	82
4.5.13.3	SwMI rejects provision of GSKO.....	83
5	Enable and disable mechanism.....	83
5.1	General relationships.....	83
5.2	Enable/disable state transitions.....	84
5.3	Mechanisms.....	84
5.3.1	Disable of MS equipment.....	85
5.3.2	Disable of an subscription.....	85
5.3.3	Disable of subscription and equipment.....	85
5.3.4	Enable an MS equipment.....	85
5.3.5	Enable an MS subscription.....	85
5.3.6	Enable an MS equipment and subscription.....	85
5.4	Enable/disable protocol.....	86
5.4.1	General case.....	86
5.4.2	Status of cipher key material.....	87
5.4.2.1	Permanently disabled state.....	87
5.4.2.2	Temporarily disabled state.....	87
5.4.3	Specific protocol exchanges.....	88
5.4.3.1	Disabling an MS with mutual authentication.....	88
5.4.3.2	Enabling an MS with mutual authentication.....	89
5.4.3.3	Enabling an MS with non-mutual authentication.....	90
5.4.3.4	Disabling an MS with non-mutual authentication.....	91
5.4.4	Enabling an MS without authentication.....	93
5.4.5	Disabling an MS without authentication.....	94
5.4.6	Rejection of enable or disable command.....	94
5.4.6a	Expiry of Enable/Disable protocol timer.....	95
5.4.7	MM service primitives.....	95
5.4.7.1	TNMM-DISABLING primitive.....	96
5.4.7.2	TNMM-ENABLING primitive.....	96
6	Air Interface (AI) encryption.....	96
6.1	General principles.....	96
6.2	Security class.....	97
6.2.0	Notification of security class.....	98
6.2.0.1	Security Class of Neighbouring Cells.....	98

6.2.0.2	Identification of MS security capabilities	99
6.2.1	Constraints on LA arising from cell class	99
6.3	Key Stream Generator (KSG)	99
6.3.1	KSG numbering and selection	99
6.3.2	Interface parameters.....	100
6.3.2.1	Initial Value (IV).....	100
6.3.2.2	Cipher Key	100
6.4	Encryption mechanism	101
6.4.1	Allocation of KSS to logical channels	101
6.4.2	Allocation of KSS to logical channels with PDU association	103
6.4.2.1	General	103
6.4.2.2	KSS allocation on phase modulation channels.....	103
6.4.2.3	KSS allocation on QAM channels	105
6.4.2.3.1	Fixed mapping	105
6.4.2.3.2	Offset mapping	106
6.4.3	Synchronization of data calls where data is multi-slot interleaved	107
6.4.4	Recovery of stolen frames from interleaved data	108
6.5	Use of cipher keys	108
6.5.1	Identification of encryption state of downlink MAC PDUs	109
6.5.1.1	Class 1 cells.....	109
6.5.1.2	Class 2 cells.....	110
6.5.1.3	Class 3 cells.....	110
6.5.2	Identification of encryption state of uplink MAC PDUs	110
6.6	Mobility procedures	111
6.6.1	General requirements.....	111
6.6.1.1	Additional requirements for class 3 systems	111
6.6.2	Protocol description	111
6.6.2.1	Negotiation of cipher parameters	111
6.6.2.1.1	Class 1 cells	112
6.6.2.1.2	Class 2 cells	112
6.6.2.1.3	Class 3 cells	112
6.6.2.2	Initial and undeclared cell re-selection.....	112
6.6.2.3	Unannounced cell re-selection	113
6.6.2.4	Announced cell re-selection type-3.....	114
6.6.2.5	Announced cell re-selection type-2.....	114
6.6.2.6	Announced cell re-selection type-1	114
6.6.2.7	Key forwarding	114
6.7	Encryption control.....	116
6.7.1	Data to be encrypted	116
6.7.1.1	Downlink control channel requirements	116
6.7.1.2	Encryption of MAC header elements	116
6.7.1.3	Traffic channel encryption control.....	116
6.7.1.4	Handling of PDUs that do not conform to negotiated ciphering mode	117
6.7.2	Service description and primitives.....	117
6.7.2.1	Mobility Management (MM)	118
6.7.2.2	Mobile Link Entity (MLE).....	118
6.7.2.3	Layer 2	120
6.7.3	Protocol functions	120
6.7.3.1	MM	120
6.7.3.2	MLE	120
6.7.3.3	LLC	120
6.7.3.4	MAC	121
6.7.4	PDUs for cipher negotiation	121
Annex A (normative): PDU and element definitions		122
A.1	Authentication PDUs.....	122
A.1.1	D-AUTHENTICATION demand	122
A.1.2	D-AUTHENTICATION reject.....	122
A.1.3	D-AUTHENTICATION response.....	123
A.1.4	D-AUTHENTICATION result.....	123
A.1.5	U-AUTHENTICATION demand	123

A.1.6	U-AUTHENTICATION reject.....	124
A.1.7	U-AUTHENTICATION response.....	124
A.1.8	U-AUTHENTICATION result.....	125
A.2	OTAR PDUs	125
A.2.1	D-OTAR CCK Provide	125
A.2.2	U-OTAR CCK Demand	125
A.2.3	U-OTAR CCK Result	126
A.2.4	D-OTAR GCK Provide	126
A.2.5	U-OTAR GCK Demand	127
A.2.6	U-OTAR GCK Result	128
A.2.6a	D-OTAR GCK Reject	128
A.2.7	D-OTAR SCK Provide.....	129
A.2.8	U-OTAR SCK Demand.....	130
A.2.9	U-OTAR SCK Result.....	130
A.2.9a	D-OTAR SCK Reject.....	131
A.2.10	D-OTAR GSKO Provide.....	131
A.2.11	U-OTAR GSKO Demand	132
A.2.12	U-OTAR GSKO Result.....	132
A.2.12a	D-OTAR GSKO Reject.....	132
A.3	PDUs for key association to GTSI	133
A.3.1	D-OTAR KEY ASSOCIATE demand	133
A.3.2	U-OTAR KEY ASSOCIATE status.....	134
A.4	PDUs to synchronize key or security class change	134
A.4.1	D-CK CHANGE demand.....	134
A.4.2	U-CK CHANGE result.....	135
A.4a	PDUs to delete air interface keys in MS	136
A.4a.1	D-OTAR KEY DELETE demand	136
A.4a.2	U-OTAR KEY DELETE result.....	137
A.4b	PDUs to obtain Air Interface Key Status	138
A.4b.1	D-OTAR KEY STATUS demand.....	138
A.4b.2	U-OTAR KEY STATUS response.....	139
A.5	Other security domain PDUs.....	140
A.5.1	U-TEI PROVIDE	140
A.5.2	U-OTAR PREPARE	141
A.5.3	D-OTAR NEWCELL.....	141
A.5.4	D-OTAR CMG GTSI PROVIDE.....	141
A.5.5	U-OTAR CMG GTSI RESULT	142
A.6	PDUs for Enable and Disable.....	142
A.6.1	D-DISABLE.....	142
A.6.2	D-ENABLE.....	143
A.6.3	U-DISABLE STATUS	143
A.7	MM PDU type 3 information elements coding	144
A.7.1	Authentication downlink	144
A.7.2	Authentication uplink	144
A.8	PDU Information elements coding.....	145
A.8.1	Acknowledgement flag.....	145
A.8.2	Address extension.....	145
A.8.3	Authentication challenge	145
A.8.4	Authentication reject reason	145
A.8.5	Authentication result	146
A.8.6	Authentication sub-type	146
A.8.7	CCK identifier	146
A.8.8	CCK information.....	146
A.8.9	CCK Location area information	147
A.8.10	CCK request flag	147
A.8.11	Change of security class	147
A.8.12	Cipher parameters.....	147

A.8.13	CK provision flag	148
A.8.14	CK provisioning information	148
A.8.15	CK request flag.....	148
A.8.16	Class Change flag.....	149
A.8.17	DCK forwarding result.....	149
A.8.18	Disabling type	149
A.8.19	Enable/Disable result.....	149
A.8.20	Encryption mode	150
A.8.20.1	Class 1 cells	150
A.8.20.2	Class 2 cells	150
A.8.20.3	Class 3 cells	150
A.8.21	Equipment disable	150
A.8.22	Equipment enable.....	151
A.8.23	Equipment status	151
A.8.23a	Explicit response	151
A.8.24	Frame number	151
A.8.25	Future key flag	151
A.8.26	GCK data.....	152
A.8.27	GCK key and identifier	152
A.8.28	GCK Number (GCKN)	152
A.8.28a	GCK Provision result	152
A.8.28b	GCK rejected.....	153
A.8.29	GCK select number	153
A.8.29a	GCK Supported	153
A.8.30	GCK Version Number (GCK-VN).....	153
A.8.31	Group association.....	154
A.8.31a	Group Identity Security Related Information	154
A.8.32	GSKO Version Number (GSKO-VN).....	154
A.8.33	GSSI	154
A.8.34	Hyperframe number	154
A.8.35	Intent/confirm.....	154
A.8.36	Void.....	155
A.8.37	Key association status	155
A.8.38	Key association type.....	155
A.8.39	Key change type	155
A.8.39a	Key delete type.....	156
A.8.39b	Key status type	156
A.8.40	Key type flag	156
A.8.41	KSG-number	157
A.8.42	Location area	157
A.8.43	Location area bit mask	157
A.8.44	Location area selector.....	157
A.8.45	Location area list	157
A.8.46	Location area range	158
A.8.46a	Max response timer value.....	158
A.8.47	Mobile country code.....	158
A.8.48	Mobile network code.....	158
A.8.49	Multiframe number.....	158
A.8.50	Mutual authentication flag.....	158
A.8.51	Network time.....	158
A.8.52	Number of GCKs changed	159
A.8.52a	Number of GCKs deleted	159
A.8.52b	Number of GCK status	159
A.8.52c	Number of GCKs provided	159
A.8.52d	Number of GCKs rejected.....	160
A.8.52e	Number of GCKs requested by GCKN	160
A.8.52f	Number of GCKs requested by GSSI.....	160
A.8.53	Number of groups.....	161
A.8.53a	Number of GSKO status.....	161
A.8.54	Number of location areas	161
A.8.55	Number of SCKs changed.....	161
A.8.55a	Number of SCKs deleted.....	162

A.8.56	Number of SCKs provided	162
A.8.56a	Number of SCKs rejected.....	162
A.8.57	Number of SCKs requested	163
A.8.57a	Number of SCK status.....	163
A.8.57b	OTAR reject reason.....	163
A.8.57c	OTAR retry interval	164
A.8.58	OTAR sub-type	164
A.8.59	PDU type.....	165
A.8.60	Proprietary	165
A.8.61	Provision result.....	165
A.8.62	Random challenge	165
A.8.63	Random seed	166
A.8.64	Random seed for OTAR.....	166
A.8.65	Void.....	166
A.8.66	Response value	166
A.8.67	SCK data	166
A.8.68	SCK information	167
A.8.69	SCK key and identifier	167
A.8.70	SCK Number (SCKN).....	167
A.8.71	SCK number and result	168
A.8.72	SCK provision flag	168
A.8.72a	Void.....	168
A.8.72b	SCK rejected	168
A.8.73	SCK select number	168
A.8.73a	SCK subset grouping type	169
A.8.73b	SCK subset number	169
A.8.74	SCK use.....	169
A.8.75	SCK version number	170
A.8.76	Sealed Key (Sealed CCK, Sealed SCK, Sealed GCK, Sealed GSKO).....	170
A.8.77	Security information element	170
A.8.77a	Security related information element	171
A.8.78	Session key	171
A.8.79	Slot Number	171
A.8.80	SSI	171
A.8.81	Subscription disable	172
A.8.82	Subscription enable	172
A.8.83	Subscription status.....	172
A.8.84	TEI.....	172
A.8.85	TEI request flag	173
A.8.85a	Timeshare cell and AI encryption information.....	173
A.8.86	Time type.....	173
A.8.87	Type 3 element identifier	174

Annex B (normative):	Boundary conditions for the cryptographic algorithms and procedures	175
B.1	Dimensioning of the cryptographic parameters	180
B.2	Summary of the cryptographic processes.....	181
Annex C (normative):	Timers	183
C.1	T354, authorization protocol timer.....	183
C.2	T371, Delay timer for group addressed delivery of SCK and GCK.....	183
C.3	T372, Key forwarding timer.....	183
C.4	T355, disable control timer	183
Annex D (informative):	Bibliography.....	184
Annex E (informative):	Change request history.....	185
History		186

Intellectual Property Rights

IPRs essential or potentially essential to the present document may have been declared to ETSI. The information pertaining to these essential IPRs, if any, is publicly available for **ETSI members and non-members**, and can be found in ETSI SR 000 314: *"Intellectual Property Rights (IPRs); Essential, or potentially Essential, IPRs notified to ETSI in respect of ETSI standards"*, which is available from the ETSI Secretariat. Latest updates are available on the ETSI Web server (<http://webapp.etsi.org/IPR/home.asp>).

Pursuant to the ETSI IPR Policy, no investigation, including IPR searches, has been carried out by ETSI. No guarantee can be given as to the existence of other IPRs not referenced in ETSI SR 000 314 (or the updates on the ETSI Web server) which are, or may be, or may become, essential to the present document.

Foreword

This European Standard (Telecommunications series) has been produced by ETSI Technical Committee Terrestrial Trunked Radio (TETRA), and is now submitted for the Vote phase of the ETSI standards Two-step Approval Procedure.

The present document is part 7 of a multi-part deliverable covering the Voice plus Data (V+D), as identified below:

EN 300 392-1: "General network design";

EN 300 392-2: "Air Interface (AI)";

EN 300 392-3: "Interworking at the Inter-System Interface (ISI)";

ETS 300 392-4: "Gateways basic operation";

EN 300 392-5: "Peripheral Equipment Interface (PEI)";

EN 300 392-7: "Security";

EN 300 392-9: "General requirements for supplementary services";

EN 300 392-10: "Supplementary services stage 1";

EN 300 392-11: "Supplementary services stage 2";

EN 300 392-12: "Supplementary services stage 3";

ETS 300 392-13: "SDL model of the Air Interface (AI)";

ETS 300 392-14: "Protocol Implementation Conformance Statement (PICS) proforma specification";

TS 100 392-15: "TETRA frequency bands, duplex spacings and channel numbering";

TS 100 392-16: "Network Performance Metrics";

TR 100 392-17: "TETRA V+D and DMO specifications";

TS 100 392-18: "Air interface optimized applications".

NOTE: Part 10, sub-part 15 (Transfer of control), part 13 (SDL) and part 14 (PICS) of this multi-part deliverable are in status "historical" and are not maintained.

Proposed national transposition dates	
Date of latest announcement of this EN (doa):	3 months after ETSI publication
Date of latest publication of new National Standard or endorsement of this EN (dop/e):	6 months after doa
Date of withdrawal of any conflicting National Standard (dow):	6 months after doa

1 Scope

The present document defines the Terrestrial Trunked Radio system (TETRA) supporting Voice plus Data (V+D). It specifies the air interface, the inter-working between TETRA systems and to other systems via gateways, the terminal equipment interface on the mobile station, the connection of line stations to the infrastructure, the security aspects in TETRA networks, the management services offered to the operator, the performance objectives, and the supplementary services that come in addition to the basic and teleservices.

The present part describes the security mechanisms in TETRA V+D. It provides mechanisms for confidentiality of control signalling and user speech and data at the air interface, authentication and key management mechanisms for the air interface.

Clause 4 describes the authentication and key management mechanisms for the TETRA air interface. The following two authentication services have been specified for the air-interface in ETR 086-3 [10], based on a threat analysis:

- authentication of an MS by the TETRA infrastructure;
- authentication of the TETRA infrastructure by an MS.

Clause 5 describes the mechanisms and protocol for enable and disable of both the mobile station equipment and the mobile station user's subscription.

Air interface encryption may be provided as an option in TETRA. Where employed, clause 6 describes the confidentiality mechanisms using encryption on the air interface, for circuit mode speech, circuit mode data, packet data and control information. Clause 6 describes both encryption mechanisms and mobility procedures. It also details the protocol concerning control of encryption at the air interface.

The present document does not address the detail handling of protocol errors or any protocol mechanisms when TETRA is operating in a degraded mode. These issues are implementation specific and therefore fall outside the scope of the TETRA standardization effort.

The detail description of the Authentication Centre is outside the scope of the present document.

2 References

References are either specific (identified by date of publication and/or edition number or version number) or non-specific.

- For a specific reference, subsequent revisions do not apply.
- Non-specific reference may be made only to a complete document or a part thereof and only in the following cases:
 - if it is accepted that it will be possible to use all future changes of the referenced document for the purposes of the referring document;
 - for informative references.

Referenced documents which are not found to be publicly available in the expected location might be found at <http://docbox.etsi.org/Reference>.

For online referenced documents, information sufficient to identify and locate the source shall be provided. Preferably, the primary source of the referenced document should be cited, in order to ensure traceability. Furthermore, the reference should, as far as possible, remain valid for the expected life of the document. The reference shall include the method of access to the referenced document and the full network address, with the same punctuation and use of upper case and lower case letters.

NOTE: While any hyperlinks included in this clause were valid at the time of publication ETSI cannot guarantee their long term validity.

2.1 Normative references

The following referenced documents are indispensable for the application of the present document. For dated references, only the edition cited applies. For non-specific references, the latest edition of the referenced document (including any amendments) applies.

- [1] ETSI EN 300 392-1: "Terrestrial Trunked Radio (TETRA); Voice plus Data (V+D); Part 1: General network design".
- [2] ETSI EN 300 392-2: "Terrestrial Trunked Radio (TETRA); Voice plus Data (V+D); Part 2: Air Interface (AI)".
- [3] ISO 7498-2: "Information processing systems - Open Systems Interconnection - Basic Reference Model - Part 2: Security Architecture".
- [4] ETSI EN 300 812: "Terrestrial Trunked Radio (TETRA); Security aspects; Subscriber Identity Module to Mobile Equipment (SIM-ME) interface".
- [5] ETSI EN 300 396-6: "Terrestrial Trunked Radio (TETRA); Direct Mode Operation (DMO); Part 6: Security".
- [6] ETSI EN 302 109: "Terrestrial Trunked Radio (TETRA); Security; Synchronization mechanism for end-to-end encryption".
- [7] ETSI EN 300 392-12-22: "Terrestrial Trunked Radio (TETRA); Voice plus Data (V+D); Part 12: Supplementary services stage 3; Sub-part 22: Dynamic Group Number Assignment (DGNA)".

2.2 Informative references

The following referenced documents are not essential to the use of the present document but they assist the user with regard to a particular subject area. For non-specific references, the latest version of the referenced document (including any amendments) applies.

- [8] ETSI ETS 300 392-2 (1996): "Terrestrial Trunked Radio (TETRA); Voice plus Data (V+D); Part 2: Air Interface (AI)".
- [9] ETSI ETS 300 392-7: "Terrestrial Trunked Radio (TETRA); Voice plus Data (V+D); Part 7: Security".
- [10] ETSI ETR 086-3: "Trans European Trunked Radio (TETRA) systems; Technical requirements specification; Part 3: Security aspects".
- [11] ETSI EN 300 392-7 (V2.3.1): "Terrestrial Trunked Radio (TETRA); Voice plus Data (V+D); Part 7: Security".
- [12] ETSI EN 300 392-7 (V2.1.1): "Terrestrial Trunked Radio (TETRA); Voice plus Data (V+D); Part 7: Security".

3 Definitions and abbreviations

3.1 Definitions

For the purposes of the present document, the following terms and definitions apply:

Authentication Code (AC): (short) sequence to be entered by the user into the MS that may be used in addition to the UAK to generate K with algorithm TB3

authentication Key (K): primary secret, the knowledge of which has to be demonstrated for authentication

authentication session: period between consecutive successful authentication operations

CCK Identifier (CCK-id): identification of the key within an LA

cipher key: value that is used to determine the transformation of plain text to cipher text in a cryptographic algorithm

cipher text: data produced through the use of encipherment

NOTE: The semantic content of the resulting data is not available (see ISO 7498-2 [3]).

class: See security class.

Common Cipher Key (CCK): cipher key that is generated by the infrastructure to protect group addressed signalling and traffic

NOTE: CCK is also used to protection of SSI identities (ESI) in layer 2.

Crypto Management Group (CMG): group of MSs with common key material

DCK forwarding: action of the SwMI whereby a DCK that has already been established with an MS is sent to a cell defined by the MS, at the request of the MS

NOTE: The purpose is to allow the MS to subsequently perform reselection to that cell and use encrypted location updating.

DCK retrieval: action of the SwMI whereby a DCK that has already been established with an MS is sent to a cell to which the MS location updates, without any previous knowledge that the MS is going to perform location updating to that cell

NOTE: The purpose is to allow the MS to perform encrypted location updating on that cell without any prior forwarding transaction. The SwMI may be able to perform DCK retrieval during initial registration, during cell reselection, or both.

decipherment: reversal of a corresponding reversible encipherment

NOTE: See ISO 7498-2 [3].

Derived Cipher Key (DCK): key generated during authentication for use in protection of individually addressed signalling and traffic

encipherment: cryptographic transformation of data to produce cipher text

NOTE: See ISO 7498-2 [3].

Encryption Cipher Key (ECK): cipher key that is used as input to the encryption algorithm

NOTE: This key is derived from one of SCK, DCK, MGCK or CCK and modified using an algorithm by the broadcast data of the serving cell.

encryption mode: choice between static (SCK) and dynamic (DCK/CCK) encipherment

encryption state: encryption on or off

end-to-end encryption: encryption within or at the source end system, with the corresponding decryption occurring only within or at the destination end system

NOTE: Defined in EN 302 109 [6].

Extended Group Session Key for OTAR (EGSKO): cipher key used for distribution of keys to groups of MSs

fallback SCK: key used by class 3 system when operating in class 2, for example in a fault or fallback situation

Group Cipher Key (GCK): cipher key known by the infrastructure and MS to protect group addressed signalling and traffic

NOTE: Not used directly at the air interface but modified by CCK to give a Modified Group Cipher Key (MGCK).

Group Session Key for OTAR (GSKO): cipher key used to derive EGSKO for the distribution of keys to groups of MSs

Initialization Value (IV): sequence of symbols that randomize the KSG inside the encryption unit

key association group: set of keys associated with one GSSI at different periods of time

key stream: pseudo random stream of symbols that is generated by a KSG for encipherment and decipherment

Key Stream Generator (KSG): cryptographic algorithm which produces a stream of binary digits, which can be used for encipherment and decipherment

NOTE: The initial state of the KSG is determined by the IV value.

Key Stream Segment (KSS): key stream of arbitrary length

Location Area identifier (LA-id): unique identifier within a SwMI of a location area

Manipulation Flag (MF): flag used to indicate that a sealed cipher key (CCK, SCK, GCK or GSKO) has been incorrectly recovered

Modified Group Cipher Key (MGCK): cipher key known by the infrastructure and MS to protect group addressed signalling and traffic that is composed algorithmically from CCK and GCK

Over The Air Re-keying (OTAR): method by which the SwMI can transfer secret keys securely to terminals

Personal Identification Number (PIN): entered by the user into the MS and used to authenticate the user to the MS

plain text: un-encrypted source data

NOTE: The semantic content is available.

proprietary algorithm: algorithm which is the intellectual property of a legal entity

Random Challenge (RAND1, RAND2): random value generated by the infrastructure to authenticate an MS or in an MS to authenticate the infrastructure, respectively

Random Seed (RS): random value used to derive a session authentication key from the authentication key

Random Seed for OTAR (RSO): random value used to derive a session key for OTAR from an MS's authentication key

Registered Area (RA): collection of Location Areas (LA) to which the MS may perform cell re-selection without need for explicit invocation of the registration protocol

Response (RES1, RES2): value calculated in the MS from RAND1 and the KS to prove the authenticity of an MS to the infrastructure or by the infrastructure from RAND2 and the KS' to prove its authenticity to an MS, respectively

SCK-set: collective term for a group of up to 32 SCK which may be held by an MS

Sealed Cipher Key (SxCK): cipher key that has been cryptographically protected

security class 1, 2 or 3: classification of terminal and SwMI encryption and authentication support

NOTE 1: See table 1.

NOTE 2: In the above definition x refers to Common, Group, Static.

Session authentication Key (KS, KS'): generated from the authentication key and a random seed for authentication

NOTE: It has a more limited lifetime than the authentication key and can be stored in less secure places and forwarded to visited networks.

Session Key for OTAR (KSO): derived from a MS's authentication key and a random seed for OTAR

NOTE: KSO is used to protect the transfer of the Static Cipher Key.

Static Cipher Key (SCK): predetermined cipher key that may be used to provide confidentiality in class 2 systems with a corresponding algorithm and may also be used in DMO or for fallback

TETRA algorithm: mathematical description of a cryptographic process used for either of the security processes authentication or encryption

time stamp: sequence of symbols that represents the time of day

User Authentication Key (UAK): key stored in a (possibly detachable) module within the MS and used to derive the authentication key (with or without a PIN as an additional parameter)

3.2 Abbreviations

For the purposes of the present document, the following abbreviations apply:

AC	Authentication Code
AESI	Alias Encrypted Short Identity
AI	Air Interface
ASSI	Alias Short Subscriber Identity
BNCH	Broadcast Network CHannel
BS	Base Station
CC	Colour Code
CCK	Common Cipher Key
CCK-id	CCK-identifier
CK	Cipher Key
CMG	Crypto Management Group
CN	Carrier Number
C-PLANE	Control-PLANE
DCK	Derived Cipher Key

NOTE: DCK1 and DCK2 are components of the Derived Cipher Key.

DMO	Direct Mode Operation
DM-SCK	SCK used in Direct Mode operation
ECK	Encryption Cipher Key
EGSKO	Extended Group Session Key for OTAR
ESI	Encrypted Short Identity
FACCH	Fast Associated Control CHannel
FEC	Forward Error Correction
GCK	Group Cipher Key
GCKN	Group Cipher Key Number
GCK-VN	GCK-Version Number
GESI	Group Encrypted Short Identity
GSKO	Group Session Key for OTAR
GSKO-VN	GSKO-Version Number
GSSI	Group Short Subscriber Identity
GTSI	Group TETRA Subscriber Identity
IESI	Individual Encrypted Short Identity
ISSI	Individual Short Subscriber Identity
ITSI	Individual TETRA Subscriber Identity
IV	Initialization Value
K	authentication Key
KAG	Key Association Group
KS, KS'	Session authentication Key
KSG	Key Stream Generator
KSO	Session Key for OTAR
KSS	Key Stream Segment
LA	Location Area
LA-id	Location Area-identifier
LLC	Logical Link Control
MAC	Medium Access Control
MF	Manipulation Flag

MGCK	Modified Group Cipher Key
MLE	Mobile Link Entity
MM	Mobility Management
MS	Mobile Station
MSC	Message Sequence Chart
OTAR	Over The Air Re-keying
PDU	Protocol Data Unit
PIN	Personal Identification Number
RA	Registered Area
RAND1	RANdOm challenge 1
RAND2	RANdOm challenge 2
RES1	RESponse 1
RES2	RESponse 2
RS	Random Seed
RSO	Random Seed for OTAR
SACCH	Slow Associated Control CHannel
SAP	Service Access Point
SCCK	Sealed Common Cipher Key
SCH	Signalling CHannel
SCH/F	Full Slot Signalling Channel
SCH/HD	Half-slot Downlink Signalling Channel
SCH/HU	Half-slot Uplink Signalling Channel
SCK	Static Cipher Key
SCKN	Static Cipher Key Number
SCK-VN	SCK-Version Number
SDMO	Secure Direct Mode Operation
SDU	Service Data Unit
SGCK	Sealed GCK
SGSKO	Sealed GSKO
SMI	Short Management Identity
SSCK	Sealed SCK
SS-DGNA	Supplementary Service Dynamic Group Number Assignment
SSI	Short Subscriber Identity
STCH	STealing CHannel
SwMI	Switching and Management Infrastructure
TCH	Traffic CHannel
TCH/2.4	Traffic CHannel for 2,4 kbs circuit mode data
TCH/4.8	Traffic CHannel for 4,8 kbs circuit mode data
TCH/7.2	Traffic CHannel for 7,2 kbs circuit mode data
TEA	TETRA Encryption Algorithm

NOTE: Used with specific numeric algorithm identity e.g. TEA1.

TEI	TETRA Equipment Identity
TMO	Trunked Mode Operation
TM-SCK	SCK used in Trunked Mode operation
TNMM	TETRA Network Mobility Management (refers to the SAP)
UAK	User Authentication Key
U-PLANE	User-PLANE
USSI	Unexchanged Short Subscriber Identity
XRES1	eXpected RESponse 1
XRES2	eXpected RESponse 2

4 Air Interface authentication and key management mechanisms

Authentication is optional, however, if it is used it shall be as described in this clause.

4.0 Security classes

TETRA security is defined in terms of class. Each class has associated features that are mandatory or optional and are summarized in table 1.

Table 1: Summary of Security features in TETRA by class

Class	Authentication	OTAR	Encryption	Enable-Disable
	Clause 4	Clause 4	Clause 6	Clause 5
1	O	O (see note 3)	-	O
2	O	O	M	O
3	M (see note 1)	M (see note 2)	M	O†
KEY: M = Mandatory O = Optional - = Does not apply † = Recommended				
NOTE 1: Authentication is required for generation of DCK.				
NOTE 2: OTAR for CCK is mandatory, other key management OTAR mechanisms are optional.				
NOTE 3: Required if key material is either distributed in preparation for security class transition, or during cell reselection to a cell of a different security class.				

The present document describes a system in which all signalling and traffic within that system comply with the same security class. However, signalling permits more than one security class to be supported concurrently within a SwMI, and movements between these classes are described in the present document. The SwMI shall control the state of AI encryption.

An MS may support one, several, or all security classes. Each cell supports at any one time one of the following options:

- class 1 only;
- class 2 only;
- class 2 and class 1;
- class 3 only; or
- class 3 and class 1.

Class 2 and class 3 are not permitted to be supported at the same time in any cell.

4.1 Air interface authentication mechanisms

4.1.1 Overview

The authentication method described is a symmetric secret key type. In this method one secret, the authentication key, shall be shared by each of the authenticating parties, and there should be strictly two parties with knowledge of the secret. Authentication shall be achieved by the parties proving to each other knowledge of the shared secret.

The authenticating parties shall be the authentication centre of the Switching and Management Infrastructure (SwMI) and the Mobile Station (MS). The MS is considered, for the purposes of authentication, to represent the user as defined by the Individual TETRA Subscriber Identity (ITSI). The design of the SwMI is not specified, but some other entity such as a Base Station (BS) may carry out the authentication protocol on behalf of the Authentication Centre. This entity is assumed to be trusted by the SwMI and the authentication exchange proves knowledge given to this entity by the authentication centre. This knowledge shall be the session authentication key (KS). This ensures that the authentication key K of the MS is never visible outside the Authentication Centre.

Authentication and provision of keys for use at the air interface shall be linked by the use of a common algorithm set. This algorithm set shall include a means of providing cipher keys over the air interface. The controlling party in all authentication exchanges shall be the SwMI.

NOTE: The SwMI controls access to the network and not the authentication process (i.e. successful authentication is not sufficient to guarantee access to the SwMI).

The authentication process describes a confirmed 2-pass challenge-response protocol.

It is assumed that the intra-system interface linking the authenticating entity to the authentication centre is adequately secure.

4.1.2 Authentication of an MS

In this clause, a mechanism is described that shall be used to achieve the authentication of an MS by the SwMI. This shall be done using a challenge response protocol, with a session authentication key (KS) derived from an authentication key that shall be shared by the MS and the infrastructure. The session authentication key shall be provided by an authentication centre of the home system.

The computation of the session authentication key shall be carried out by an algorithm, TA11. The computation of the response shall be done by another algorithm, TA12, which at the same time shall produce a derived cipher key.

The SwMI shall generate a random number as a challenge RAND1. The MS shall compute a response, RES1, and the SwMI shall compute an expected response, XRES1. A component of the derived cipher key shall be generated by this process, labelled DCK1. The SwMI on receipt of RES1 from the MS shall compare it with XRES1. If the values are equal the result R1 shall be set to TRUE, else the result R1 shall be set to FALSE.

The process is summarized in figure 1.

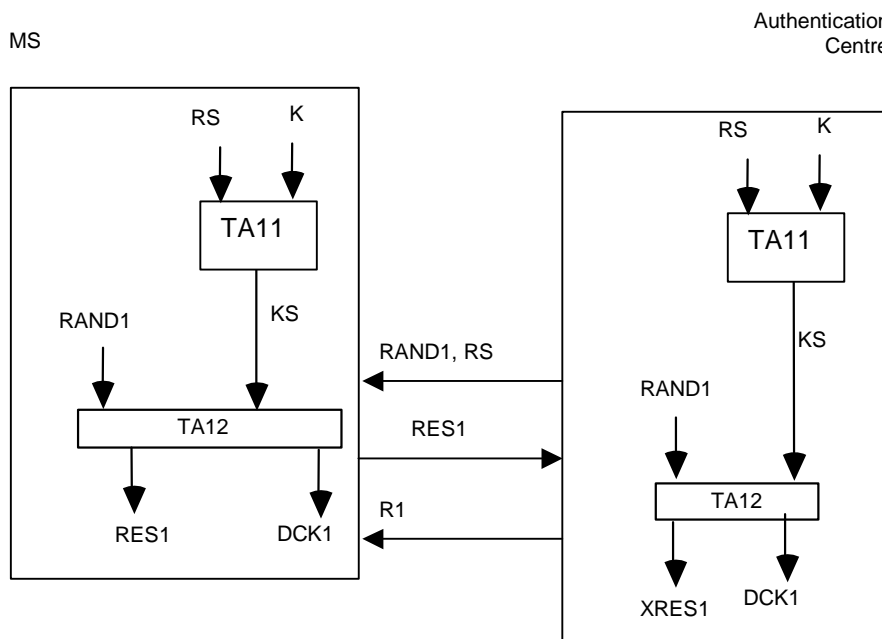

Figure 1: Authentication of a MS by the infrastructure

4.1.3 Authentication of the infrastructure

Authentication of the infrastructure by a MS shall be carried out in the same way as described in clause 4.1.2 with the roles of the challenger and challenged reversed. The MS shall generate a challenge, RAND2, the SwMI shall generate an actual response, RES2, and the MS shall generate an expected response, XRES2. A component of the derived cipher key shall be generated by this process, labelled DCK2. The MS on receipt of RES2 from the SwMI shall compare it with XRES2. If the values are equal the result R2 shall be set to TRUE, else the result R2 shall be set to FALSE.

The same authentication key K shall be used as in the case of authentication of the MS by the infrastructure together with a random seed RS. However, the algorithms shall be different: TA11 shall be replaced by TA21 and TA12 by TA22. Hence, there should also be a different value for the session authentication key, KS'. The process is summarized in figure 2.

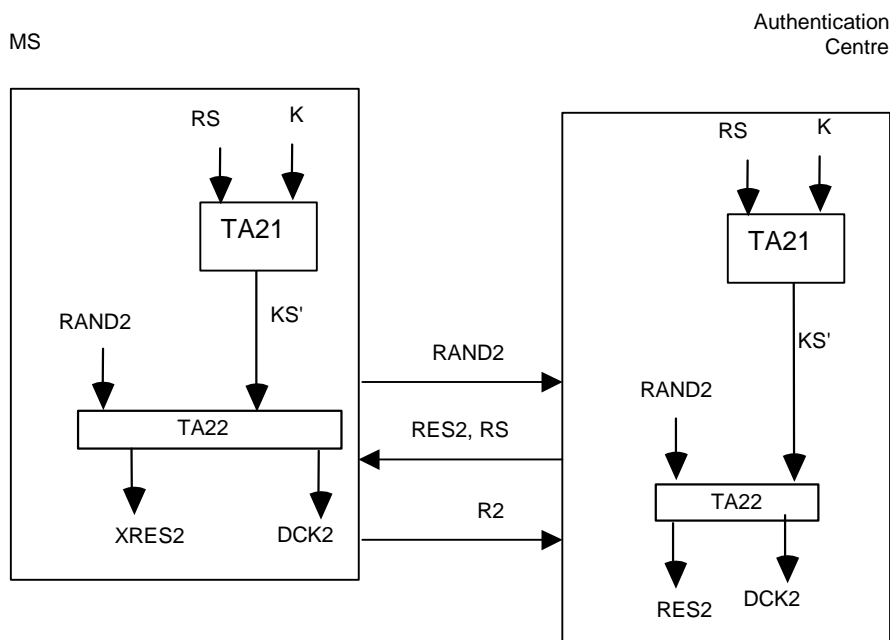

Figure 2: Authentication of the infrastructure by a MS

4.1.4 Mutual authentication of MS and infrastructure

Mutual authentication of MS and infrastructure shall be achieved using a confirmed three pass mechanism. The algorithms and key K used shall be the same as those used in the one way authentication described in the previous clauses. The decision to make the authentication mutual shall be made by the first party to be challenged, not the initial challenging party. Thus mutual authentication shall be started as a one way authentication by the first challenging party, and then made mutual by the responding party.

If the first challenging party does not support mutual authentication, then it may immediately conclude the authentication exchange by indicating a successful authentication result to the responding party. When the MS is the responding party, it determines whether or not to remain on the serving cell.

In the event that the first authentication fails, the second authentication shall be abandoned. However, if the first challenge is ignored by the initial challenged party, then the initial challenged party may instead challenge the initial challenging party. When the MS is the initial challenging party, it determines whether or not to remain on the serving cell.

If the authentication was initiated by the SwMI, it shall use K and one random seed RS with algorithms $TA11$ and $TA21$ to generate the pair of session keys KS and KS' . It shall then send random challenge $RAND1$ to the MS together with random seed RS . The MS shall run $TA11$ to generate session key KS , and because the authentication is to be made mutual it shall also run algorithm $TA21$ to generate a second session key KS' . Both MS and SwMI shall run algorithm $TA12$; the MS then sends its response $RES1$ back to the SwMI. However, the MS also sends its mutual challenge $RAND2$ to the SwMI at the same time. The SwMI shall compare the response from the MS $RES1$ with its expected response $XRES1$, and because it has received a mutual challenge, it shall run $TA21$ to generate session key KS' if it has not already done so. The SwMI shall then run $TA22$ to produce its response to the MS's challenge $RES2$. $RES2$ is sent to the MS, which shall also run $TA22$ to produce expected response $XRES2$. The MS on receipt of $RES2$ from the SwMI shall compare it with $XRES2$. If the values are equal the result $R2$ shall be set to **TRUE**, else the result $R2$ shall be set to **FALSE**. If $R2$ is **TRUE** mutual authentication will have been achieved.

Algorithms $TA12$ and $TA22$ produce $DCK1$ and $DCK2$ respectively; these shall be combined in $TB4$ by both MS and SwMI to produce a DCK which has therefore been created as a result of challenges by both parties. The algorithm $TB4$ is described in clause 4.2.1.

The process is shown in figure 3.

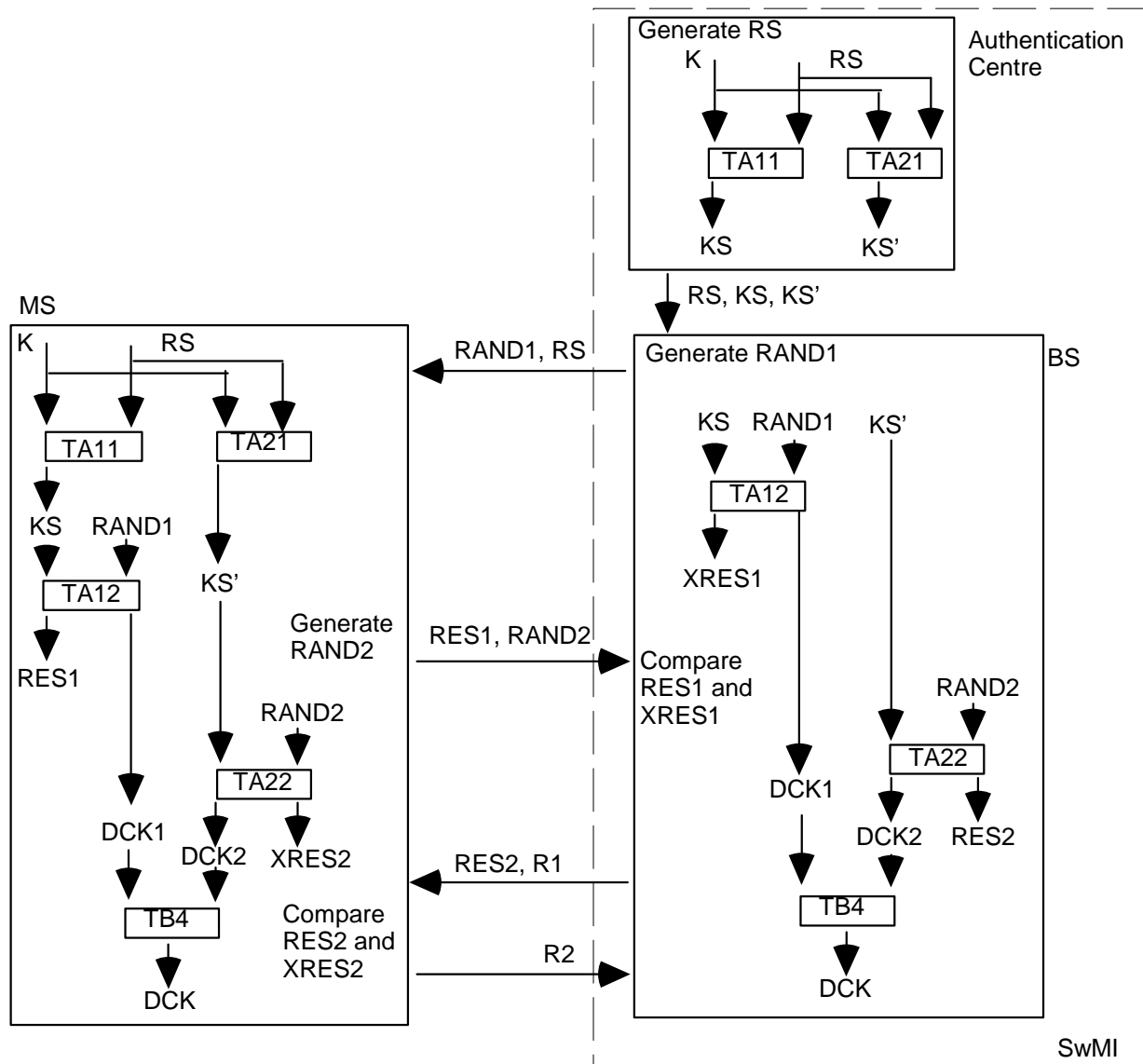

Figure 3: Mutual authentication initiated by SwMI

The mutual authentication process may also occur if a one way authentication is initiated by the MS, and then made mutual by the SwMI. In this case, the algorithms are the same, however, the sequence is reversed as shown in figure 4.

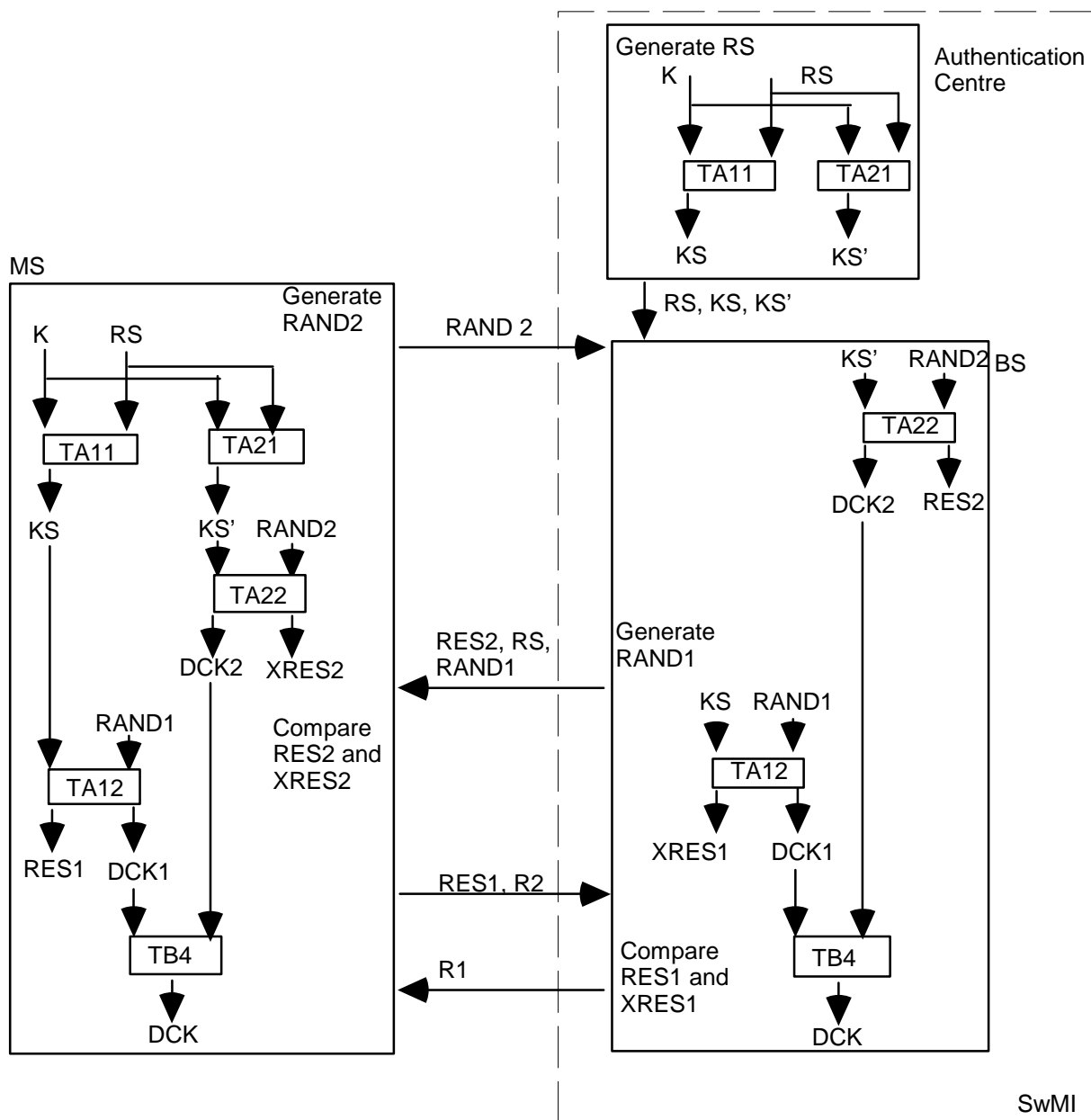

Figure 4: Mutual authentication initiated by MS

4.1.5 The authentication key

The ITSI and its associated user should be authenticated by a process that is carried out in the MS, as described in clause 4.1.2. To provide against misuse of lost, or stolen, MS, and to authenticate the user to the MS, the user should be required to make an input before K is available and valid for use. K may be stored in a module, which may or may not be detachable, and the user may be required to make an input to this module, e.g. a personal identification number (PIN).

4.1.6 Equipment authentication

The authentication of the TETRA Equipment Identity (TEI) is outside the scope of the present document. However, the protocol described in clause 4.4 provides a mechanism whereby the BS may demand an MS to provide TEI as part of the registration exchange.

4.2 Air Interface key management mechanisms

Five types of key are managed over the air interface:

- the Derived Cipher Key (DCK);
- the Common Cipher Key (CCK);
- the Group Cipher Key (GCK);
- the Group Session Key for OTAR (GSKO); and
- the Static Cipher Key (SCK).

The ESI mechanism is also described in this clause. Exchange of DCK is linked to the authentication exchange described in clause 4.1. Clauses 4.2.2 to 4.2.5 describe over the air re-keying (OTAR) that is used to exchange the remainder of these keys.

4.2.1 The DCK

DCK applies only to class 3 cells for encryption.

If DCK is used for key sealing (OTAR CCK, see clause 4.2.3) the DCK should be always be generated irrespective of the security class of the cell.

Successful authentication of the MS or the infrastructure shall result in the generation of DCK1 or DCK2, respectively. Mutual authentication shall generate both DCK1 and DCK2.

NOTE: Both the infrastructure and the terminal derive DCK during the authentication process.

The DCK shall be derived from its two parts DCK1 and DCK2 by the procedure TB4, as shown in figure 6. In case of unilateral authentication, either DCK1 or DCK2 shall be set to zero: DCK2 = 0 for an authentication of the MS by the infrastructure; DCK1 = 0 for an authentication of the infrastructure by the MS.

If mutual authentication is requested by the MS, but the SwMI does not support mutual authentication and instead concludes the authentication, then DCK2 shall be set to "0" when deriving DCK using TB4.

If mutual authentication is requested by the SwMI, but the MS does not support mutual authentication and instead concludes the authentication, then DCK1 shall be set to "0" when deriving DCK using TB4.

If MS initiated authentication is ignored by the SwMI, and instead only SwMI initiated authentication is performed, then DCK2 shall be set to "0" when deriving DCK using TB4.

If SwMI initiated authentication is ignored by the MS, and instead only MS initiated authentication is performed, then DCK1 shall be set to "0" when deriving DCK using TB4.

Figure 5: Void

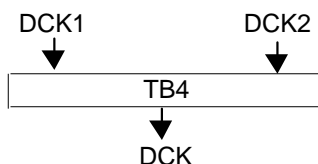

Figure 6: Derivation of the DCK from its two parts

In a successful authentication exchange the algorithm TB4 shall always be invoked in accordance with the rules for input given above.

DCK may be used to protect voice, data, and signalling sequences between the infrastructure and an individual MS after successful authentication has taken place.

4.2.2 The GCK

GCK applies only to class 3 cells for encryption.

The GCK shall be known to the infrastructure and distributed to the MSs. GCK shall not be used directly by the air interface encryption unit. Within each LA the GCK shall be modified by CCK (see clause 4.2.3) using algorithm TA71 to provide a Modified GCK (MGCK) for use on the air interface. The process is shown in figure 7.

If GCK is not defined for a group the value of MGCK shall be equal to that of CCK and algorithm TA71 shall not be invoked.

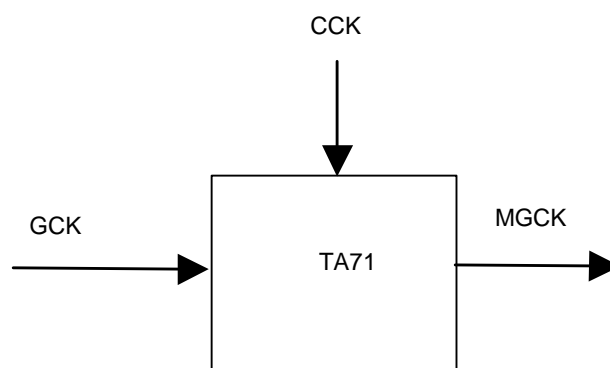

Figure 7: Generation of MGCK from GCK and CCK

One GCK may be associated with more than one group. A GCK Number (GCKN) associated with each GCK can be used to identify association with multiple groups. The values of GCKN should be unique between all MSs sharing the same sets of GCK. The association of GCK to groups may be changed by the OTAR service to allow automatic key management to take place.

When distributing GCK to an individual by an OTAR mechanism (algorithms TA81 and TA82) a session key for OTAR (KSO) may be used to protect the GCK, alternatively an EGSKO derived from GSKO may be used. The signalling shall indicate the sealing key in use. KSO shall be individual to each MS and shall be derived from an MS's authentication key (K) and a random seed RSO with algorithm TA41.

To allow the GCK to be decrypted by the MS, algorithm TA81 shall have an inverse TA82. To allow the MS to discover if GCK has been corrupted due to transmission errors or manipulation, TA81 introduces some redundancy into the Sealed Group Cipher Key (SGCK). The algorithm TA81 uses the group key version number (GCK-VN) and the Group Cipher Key Number (GCKN), to provide this redundancy. The redundancy is checked by TA82. A detected manipulation shall be indicated by setting the manipulation flag MF. The method of determining a valid GCK-VN and, therefore, of identifying a replay is outside the scope of the present document.

When distributing to a group by OTAR an EGSKO derived from GSKO shall be used as the sealing key.

If MF is TRUE the recovered key shall be discarded.

The process is summarized in figure 8.

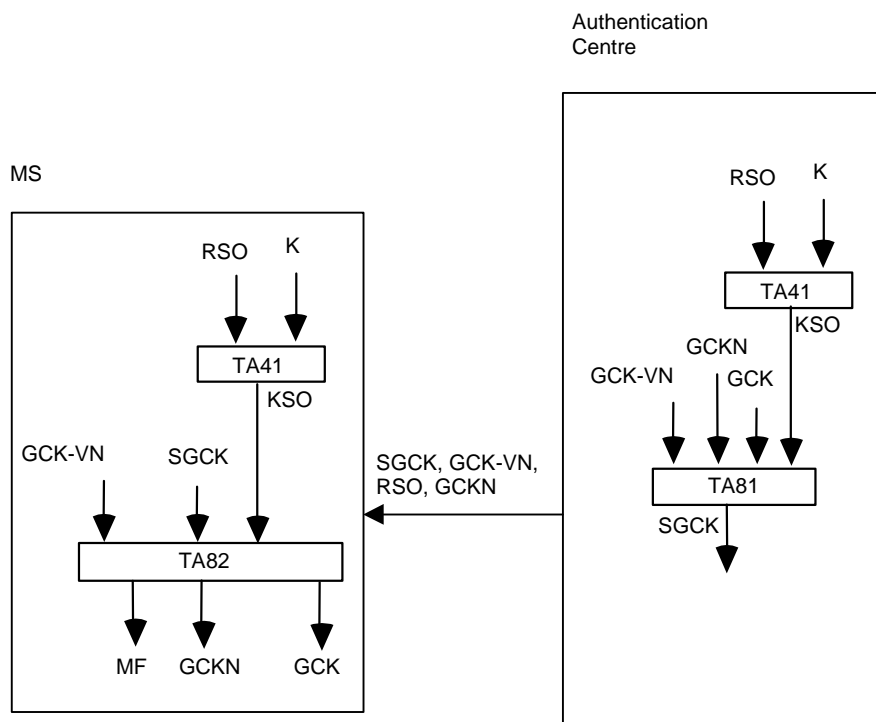

Figure 8: Distribution of a group cipher key to an individual MS

4.2.3 The CCK

CCK applies only to class 3 cells for encryption.

CCK shall be used to give protection of voice, data, and signalling sequences between the infrastructure and an MS when using group addresses (including the broadcast address) on the downlink either as a key modifier of GCK (see clause 4.2.2) or as a standalone key. In addition CCK shall be used to generate ESI as described in clause 4.2.6.

The CCK shall be generated by the infrastructure and distributed to the MSs. There shall be one such key for every Location Area (LA): a CCK may be used in more than one LA or there may be a distinct CCK for every LA in the system. The MS may request the CCK when registering in an LA as part of the registration protocol, or at any other time as part of the CCK delivery protocol. The CCK may then be transmitted in encrypted form using algorithm TA31 and DCK as the sealing key. To allow the CCK to be decrypted by the MS, algorithm TA31 shall have an inverse TA32. To allow the MS to discover if CCK has been corrupted due to transmission errors or manipulation, TA31 introduces some redundancy into the Sealed Common Cipher Key (SCCK). The redundancy is checked by TA32. A detected manipulation shall be indicated by setting the manipulation flag MF.

If MF is true the recovered key shall be discarded.

The infrastructure may change the CCK and distribute the new key to the MSs. For this purpose a CCK Identifier (CCK-id) shall be generated and distributed along with the key. CCK-id shall be input to algorithms TA31 and TA32 to the effect that decryption of the correct CCK shall only be possible if the correct CCK-id has been received. CCK-id shall be referenced by one bit in the encryption mode element of the MAC RESOURCE PDU of the encrypted message to select the active CCK. The value of this bit shall equal the value of the least significant bit of CCK-id. The method of determining a valid CCK-id and, therefore, of identifying a replay is outside the scope of the present document.

CCK is uniquely identified by the combination of LA-id and CCK-id. Where a CCK applies to many LAs the CCK-id shall be the same in each LA.

The process is summarized in figure 9.

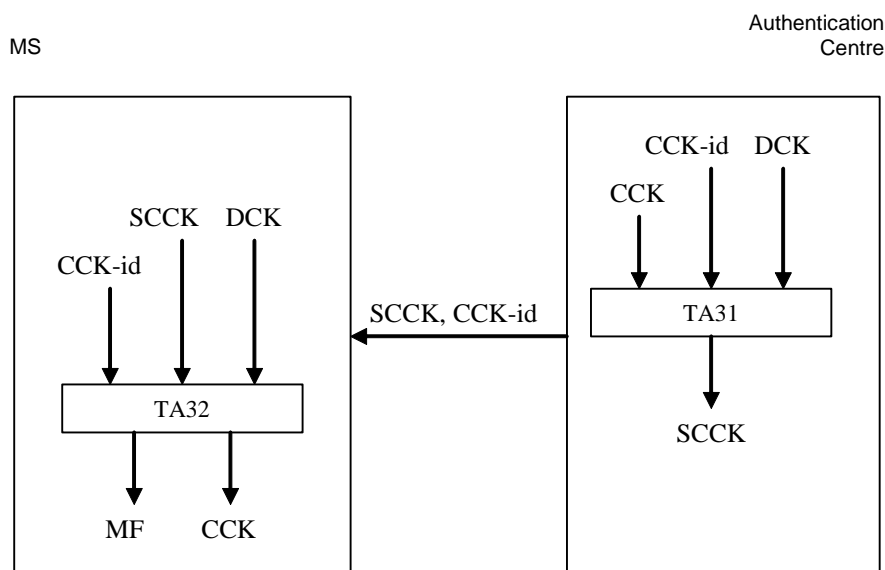

Figure 9: Distribution of a common cipher key

4.2.4 The SCK

SCK applies to class 2 cells and to Direct Mode operations (see EN 300 396-6 [5]) for encryption. SCK may also be used for encryption in a cell that normally operates in class 3 but is in fallback mode.

SCK shall be used to protect voice, data, and signalling sequences between the infrastructure and an individual MS in a class 2 cell. The SCK may be used to protect voice, data, and signalling sequences between the infrastructure and a group-addressed MS. There shall be up to 32 SCKs available to each ITSI. SCK shall be a fixed value that should be known to the infrastructure and every MS. The SCKs are termed "static" because they shall not be generated or changed by the authentication exchange.

SCK shall be a member of an SCK set containing up to 32 keys, and each key shall be identified by its position in the SCK set (SCK number). Members of an SCK set may be shared amongst TETRA networks and so may be allocated in either the home network of the MS or by an external body representing more than one TETRA network.

SCKs may be protected for distribution using algorithms TA51 and TA52, in like manner to the GCK which uses algorithms TA81 and TA82.

An SCK shall be identified by two numbers:

- The SCK number (SCKN) shall address one of the 32 SCKs stored in an MS; The SCK Version Number (SCK-VN) shall identify the version of each of the 32 SCKs and should be incremented for each new key identified with the same SCKN.
- SCK-VN may be used to protect the distribution of the SCKs against replay. The method of determining a valid SCK-VN and, therefore, of identifying a replay is outside the scope of the present document. The SCKN is input to TA51 and output from TA52.

SCK-VN shall be referenced by one bit in the encryption mode element of the MAC RESOURCE PDU of the encrypted message to select the active SCK. The value of this bit shall equal the value of the least significant bit of SCK-VN.

When distributing SCK to an individual by an OTAR mechanism (algorithms TA51 and TA52) a session key for OTAR (KSO) may be used to protect the SCK, alternatively an EGSKO derived from GSKO may be used. The signalling shall indicate the sealing key in use. KSO shall be individual to each MS and shall be derived from an MS's authentication key (K) and a random seed RSO with algorithm TA41.

When distributing to a group by OTAR an EGSKO derived from GSKO shall be used as the sealing key, as described in clause 4.2.5.

The result of the application of TA51 to SCK, SCK-VN, KSO and SCKN shall be a Sealed Static Cipher Key (SSCK). To allow recovery of SCK and SCKN at the MS, SCK-VN and RSO shall be distributed together with SSCK.

For OTAR, SCKs may be sealed in the same entity that stores the MS's authentication keys, i.e. an authentication centre. This case is shown in figure 10.

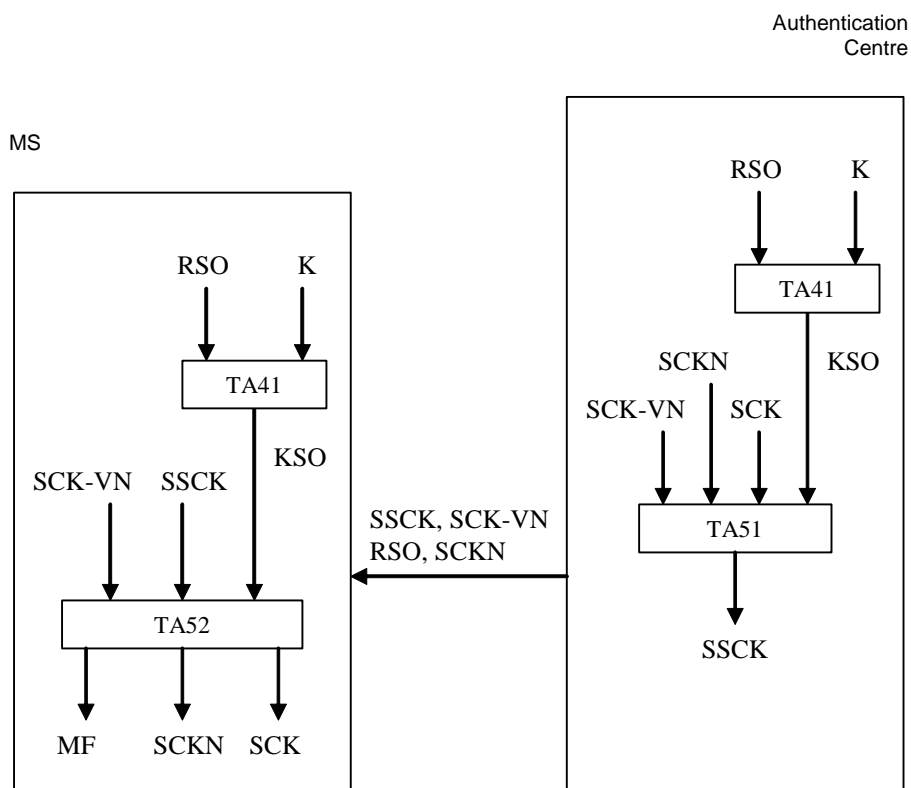

Figure 10: Distribution of SCK to an individual MS by an authentication centre

SCKs may be associated with one or more groups for encryption in DMO (see EN 300 396-6 [5]). The association principle is described in clause 4.2.4.1.

SCK may also be deleted from the MS as part of the OTAR procedures.

4.2.4.1 SCK association for DMO use

The OTAR service provided in TMO may also be used to provide key management for DMO. The OTAR service allows SCKs to be provided for use in DMO, and for one or more provided SCKs to be associated with one or more groups in DMO. The purpose of associating more than one SCK with a DMO group is to allow different SCKs to be active at different periods of time in DMO. Associations can be formed for single SCKs or for SCK subsets.

4.2.4.1.1 DMO SCK subset grouping

For each DMO group call where encryption is to be applied, the MS should have a means to associate one or more SCKs with the GTSI to be called. The means of associating SCKs with GTSIs may be achieved using air interface signalling.

An SCK should have a defined lifetime or crypto period. At the end of this crypto period, it should be replaced. Replacement is achieved when the MS selects a different SCK for transmission. However, as DMO is an uncontrolled environment, different MSs may change their SCK selection at different times. To overcome the possibilities for communication failure, SCKs may be grouped into one or more subsets to facilitate the key management process.

Keys in different subsets associated with the same GTSI(s) are referred to by the term Key Association Group (KAG). The MS shall consider one SCK of the KAG as current and shall use this SCK as the key for transmission. Any SCK of the KAG may be used for reception.

EXAMPLE 1: If SCKN#3, SCKN#13, SCKN#23 are members of the same KAG and an MS transmits using SCKN#13 then it shall also be prepared to receive using SCKN#3, SCKN#13, SCKN#23.

The SCKs within the subsets can be activated separately or synchronized and activated together. If an entire subset of SCKs is to be activated together, the crypto periods of all SCKs in the subset shall be the same, and the SCK-VNs of all SCKs in a subset shall also be the same.

Subset groups shall be identified by the SCK subset grouping type as shown in table 1a and the membership of each resulting subset shall be identified as shown in table 1b.

The SCK subset numbering shall be determined by the SCK subset grouping type. In all cases, SCK subset grouping type = 1 corresponds to the subset with SCKN = 1 as the first value. Other SCK subset grouping types are determined according to table 1b.

Table 1a: SCK subset grouping type definitions

SCK subset grouping type	Maximum number of SCK subsets (n)	Maximum number of SCKs per subset (m)	Remarks
0	1	30	Default.
1	2	15	
2	3	10	Suited for past-present-future mode of operation.
3	4	7	Only 28 keys of 30 are associated to groups.
4	5	6	
5	6	5	
6	7	4	Only 28 keys of 30 are associated to groups.
7	10	3	
8	15	2	
9	30	1	

NOTE: The maximum number of SCKs per subset is limited to 30, as SCKNs 31 and 32 are reserved for TMO use.

Table 1b: Membership by SCKN value of each subset of each SCK subset grouping type

SCK subset number	SCK subset grouping type							
	1	2	3	4	5	6	7	8
1	1 to 15	1 to 10	1 to 7	1 to 6	1 to 5	1 to 4	1 to 3	1 to 2
2	16 to 30	11 to 20	8 to 14	7 to 12	6 to 10	5 to 8	4 to 6	3 to 4
3	X	21 to 30	15 to 21	13 to 18	11 to 15	9 to 12	7 to 9	5 to 6
4	X	X	22 to 28	19 to 24	16 to 20	13 to 16	10 to 12	7 to 8
5	X	X	X	25 to 30	21 to 25	17 to 20	13 to 15	9 to 10
6	X	X	X	X	26 to 30	21 to 24	16 to 18	11 to 12
7	X	X	X	X	X	25 to 28	19 to 21	13 to 14
8	X	X	X	X	X	X	22 to 24	15 to 16
9	X	X	X	X	X	X	25 to 27	17 to 18
10	X	X	X	X	X	X	28 to 30	19 to 20
11	X	X	X	X	X	X	X	21 to 22
12	X	X	X	X	X	X	X	23 to 24
13	X	X	X	X	X	X	X	25 to 26
14	X	X	X	X	X	X	X	27 to 28
15	X	X	X	X	X	X	X	29 to 30

NOTE 1: For SCK subset grouping type = 9 (not shown), 30 subsets of 1 key each, the SCK subset number is equal to the SCKN, i.e. SCK subset number = 1 signifies SCKN = 1 and so on.

NOTE 2: A table entry given by "X" indicates an illegal value that shall not be used.

NOTE 3: For SCK subset grouping type = 0 (not shown), 1 subset of 30 keys, the SCK subset number is always 1.

All SCKNs in a KAG shall be associated with a GTSI by implication when the SCKN in that KAG that is in subset#1 is associated with that GTSI.

The association of SCKNs within a KAG with any GTSI can also be determined from the following formula:

where:

- SCK(i) are the members of a KAG;
- SCK(f) is the associated SCKN in the first subset; and
- There are (n) subsets, each containing (m) member SCKs.

Then:

```

For j = 0 to (n-1)
{
  i = f + m × j
}

```

EXAMPLE 2: Associating GTSI#22 with SCKN#3 in SCK subset grouping type 2 implies association of SCKN#3, SCKN#13 and SCKN#23 with GTSI#22, i.e. SCKN#3, SCKN#13, SCKN#23 are members of the same KAG.

EXAMPLE 3: Associating GTSI#22 with SCKN#3 in SCK subset grouping type 4 implies association of SCKN#3, SCKN#9, SCK#15, SCKN#21 and SCKN#27 with GTSI#22, i.e. SCKN#3, SCKN#9, SCKN#15, SCKN#21 and SCKN#27 are members of the same KAG.

EXAMPLE 4: If SCK subset grouping type = 2 (corresponding to 3 subsets of 10 keys), then $n = 3$, $m = 10$, and if $f = 5$, then SCKN = 5, SCKN = 15 and SCKN = 25 shall be associated with the same GTSI and are members of the same KAG.

EXAMPLE 5: Figure 10a shows an example of key association for SCK subset grouping type = 2.

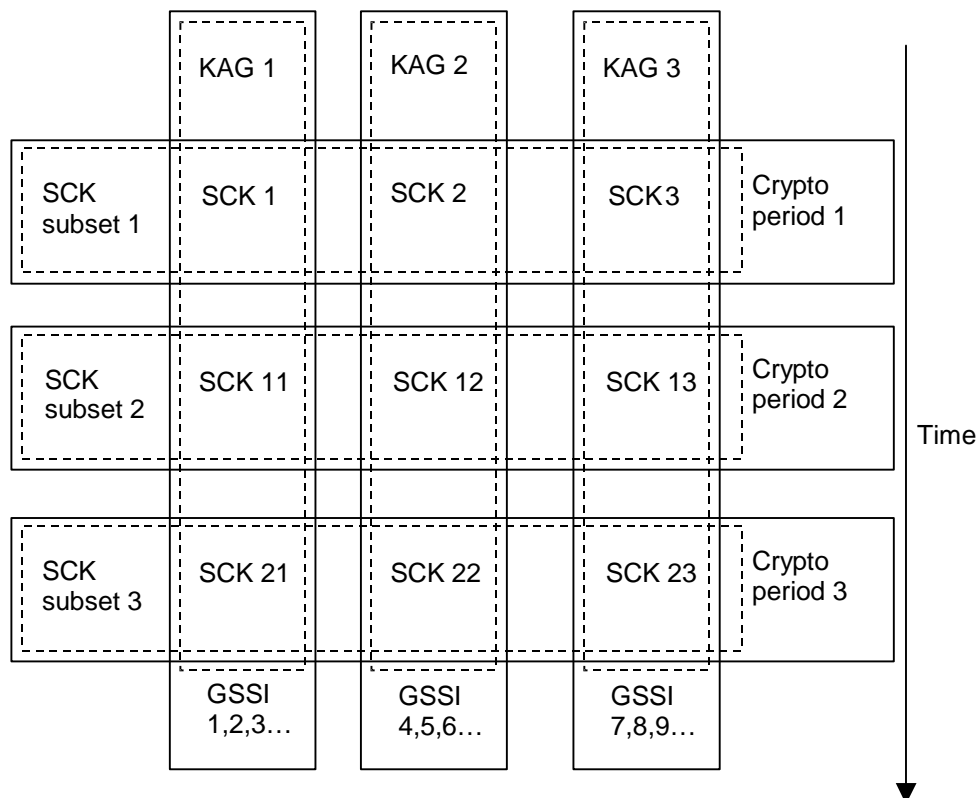

NOTE: GSSI is used in this figure to represent GTSI.

Figure 10a: Example of key association for SCK subset grouping type = 2

4.2.5 The GSKO

In some cases keys may need to be distributed to groups as identified by GTSI. In order to allow the sealing mechanisms described in clauses 4.2.2 and 4.2.4 to operate KSO shall be replaced by an Extended Group Session Key for OTAR (EGSKO) derived using algorithm TB7 from the Group Session Key for OTAR (GSKO).

When distributing GSKO by an OTAR mechanism (algorithms TA91 and TA92) a session key for OTAR (KSO) shall be used to protect the GSKO. KSO shall be individual to each MS and shall be derived from an MS's authentication key (K) and a random seed RSO with algorithm TA41 as for distribution of SCK and GCK. The GSKO has an associated version number, GSKO-VN which can be used for replay protection.

Algorithm TA91 is used with GSKO, KSO and GSKO-VN as inputs to produce a sealed key SGSKO for transmission to an MS. Recovery of GSKO from SGSKO is achieved using algorithm TA92 in conjunction with KSO and GSKO-VN as inputs. A manipulation flag MF provides assurance of correct recovery.

The process is summarized in figure 11.

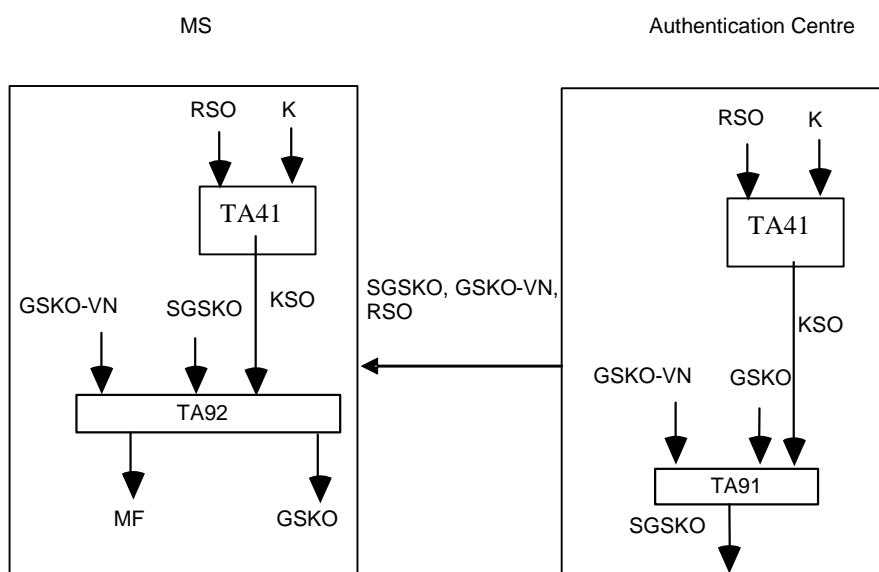

Figure 11: Distribution of GSKO by an authentication centre

4.2.5.1 SCK distribution to groups with OTAR

When distributing SCK to a group EGSKO shall be used in place of KSO as input to algorithms TA51 and TA52. Signalling shall indicate if the distributed SCK is sealed with EGSKO instead of KSO (refer to figure 10). In this case the mechanism shall be as shown in figure 10 with TA41 not invoked and KSO replaced by EGSKO.

EGSKO is derived from GSKO using algorithm TB7 as shown in figure 12.

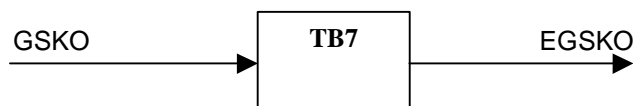

Figure 12: Generation of EGSKO using TB7

4.2.5.2 GCK distribution to groups with OTAR

When distributing GCK to a group, EGSKO shall be used in place of KSO as input to algorithms TA81 and TA82. Signalling shall indicate that the distributed GCK is sealed with EGSKO. In this case the mechanism shall be as shown in figure 8 with TA41 not invoked and KSO replaced by EGSKO.

4.2.5.3 Rules for MS response to group key distribution

Where a key is provided to the MS using a group addressed transmission, and using the GSKO for key encryption, the MS shall determine whether to respond to the group addressed OTAR distribution as follows:

- if the transmission explicitly requires MSs to respond, each MS shall respond to inform the SwMI of the success (or failure) of the transaction following expiry of timer T371 that is set to a random value on receipt of the OTAR provision;
- if the transmission does not explicitly require MSs to respond, an MS shall respond following the expiry of T371 on receipt of the OTAR provision, only if the transmission provides that MS with a key or a version of a key that the MS does not have stored;
- if the transmission does not explicitly require MSs to respond, and the transmission does not provide an MS with a key or a version of a key that the MS does not have stored, that MS shall not respond.

The maximum value to which the timer T371 may be set by the MS is provided by the SwMI.

If an MS is required to respond for one of the reasons given above, but needs to leave the SwMI by sending ITSI-Detach signalling the MS shall consider T371 to have terminated at this point, and should send the response to the OTAR signalling before detaching from the SwMI.

NOTE: If the MS is unable to send the response there is no requirement to store the response.

4.2.6 Encrypted Short Identity (ESI) mechanism

The ESI mechanism shall provide a means of protection of identities transmitted over the air interface. It operates in addition to, or as a replacement for, the Alias Short Subscriber Identity (ASSI) mechanism described in EN 300 392-1 [1], clause 7.

NOTE 1: In standard TETRA addressing no alias addresses are associated with a group address in the home system. The ESI mechanism provides such an alias within a location area for all address types.

NOTE 2: The broadcast address as defined in EN 300 392-1 [1] is a reserved value of the group address so ESI applies to it.

This clause describes a mechanism that allows the encryption of the SSI segment of addresses used by layer 2. The event label and usage marker shall not be encrypted by this mechanism. USSI and SMI shall not be encrypted by this mechanism. The mechanism is valid only for networks with air interface encryption applied. The mechanism shall be integrated with the use of CCK within a location area in cells of security class 3, or with SCK for cells of security class 2. Whenever encrypted signalling is used, the ESI shall be sent instead of the true identity. The mechanism uses algorithm TA61 as shown in figure 13.

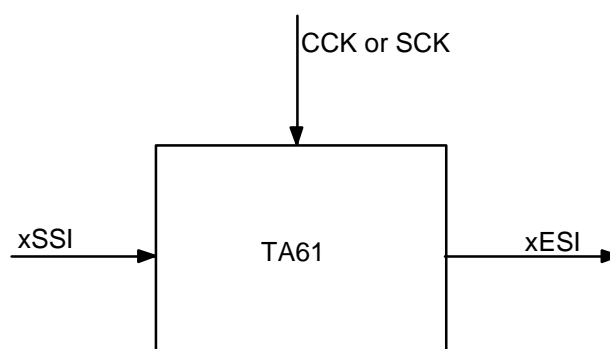

Figure 13: Generation of ESI from SSI and a cipher key

xSSI are all short addresses valid for the MS (ISSI, GSSI, ASSI, V-ASSI, V-GSSI). The output xESI (IESI, GESI, AESI, V-AESI, V-GESI) shall be a cryptographic address. Only MSs in a location area with the correct values of CCK or SCK shall be able to identify messages addressed for their attention.

If the PDU is encrypted ESI shall be used in that PDU The use of signalling for AI encryption management is more fully described in clause 6.5.

4.2.7 Encryption Cipher Key

The Encryption Cipher Key (ECK) shall be derived using algorithm TB5 from a selected CK. The CK shall be one of DCK, CCK, MGCK in class 3 cells, and shall be SCK in class 2 cells. TB5 combines CK with CN, CC and LA identifier to produce ECK. This is to prevent attacks on the encryption process by replaying cipher text to eliminate the keystream, and to prevent keystream replay within the repeat period of the frame numbering system.

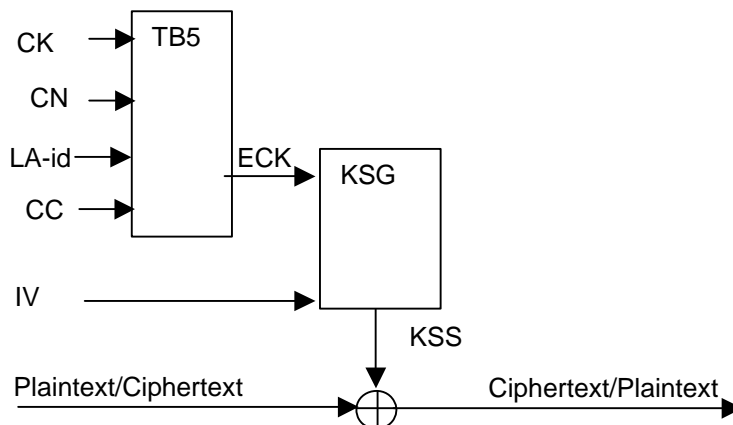

Figure 14: Use of TB5 to generate ECK

4.2.8 Summary of AI key management mechanisms

Table 2 summarizes the pre-conditions and lifetimes for each key.

Table 2: Cipher Key pre-conditions and lifetime

Key	Pre-condition	Lifetime (see note 6)
K	None	ITSI (see note 1)
DCK	Authentication	Authentication session (see note 3)
CCK	Authentication	Not defined (see note 4)
SCK	None	Not defined (see note 2)
GCK	None	Not defined (see note 5)
MGCK	Authentication	As per CCK
GSKO	None	Not defined (see note 5)

NOTE 1: If OTAR is used for SCK, K or GSKO is required.
 NOTE 2: K or GSKO is required for OTAR in class 2 and class 3.
 NOTE 3: In an MS DCK may be deleted on power down, but shall be retained if encrypted registration is required.
 NOTE 4: CCK may be deleted from the MS on power down, but shall be retained if encrypted registration is required.
 NOTE 5: Generally long life.
 NOTE 6: Refer to clause 5 for considerations of key storage resulting from invocation of the enable-disable protocols.

Figure 15 shows the fixed relationship between TETRA addresses and cipher keys. The link between each entity describes a relationship "is associated with" and the numbers on the link define the form of this relationship. For example the ITSI-K relationship shows that for each ITSI there is zero or one K, and for each K there is only one ITSI.

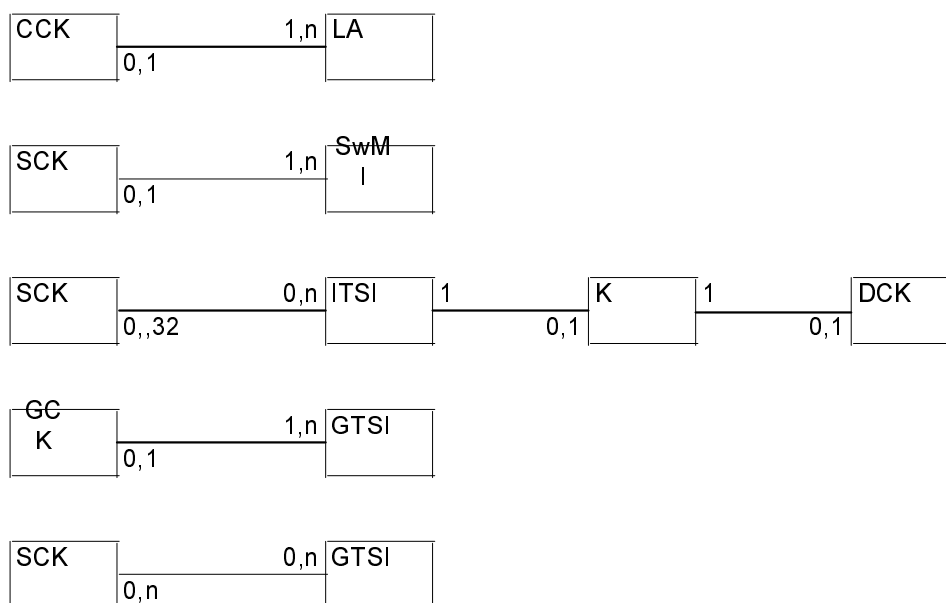

- NOTE 1: An ITSI may have 0, 1 or up to 32 SCKs associated with it.
 NOTE 2: An SCK may be associated with 0,1 or many ITSIs (in the diagram "n" represents this).
 NOTE 3: An LA may only use one CCK at any one time.
 NOTE 4: A CCK may be used in more than one LA (represented by "n").
 NOTE 5: An ITSI may have 0 or 1 key K.
 NOTE 6: Key K shall only be associated with 1 ITSI.
 NOTE 7: A SwMI shall only use one SCK at any one time except during key changeover periods (see also clause 6.5).
 NOTE 8: An SCK may be used in more than one SwMI.
 NOTE 9: A GCK may be associated with 1 or many GTSIs.
 NOTE 10: A GTSI may have 0 or 1 GCK associated with it.
 NOTE 11: One or several SCKs may be associated with 0, 1 or many GTSIs for DMO only.
 NOTE 12: A GTSI may have 0 or 1 SCK associated with it, or, for DMO only, many SCKs associated with it.
 NOTE 13: The diagram does not show transient cases where more than one version of a key may be in use.

Figure 15: Mapping of Cipher Key and TETRA address relationships

4.3 Service description and primitives

4.3.1 Authentication primitives

At the TNMM Service Access Point (SAP), a specific service shall be provided to allow an application to initiate an authentication exchange and to receive its result. The MS-MM shall respond to an authentication demand from the SwMI. The primitives required shall be as follows:

- TNMM-AUTHENTICATE indication shall be used to report to the MS application the result of an authentication returned by the SwMI.
- TNMM-AUTHENTICATE confirm shall be used to confirm successful or failed authentication of the SwMI by the MS.
- TNMM-AUTHENTICATE request shall be used by the MS application to initiate an authentication of the SwMI. It may also be used to configure the mutual authentication and registration behaviour of the MS.

Table 3: TNMM AUTHENTICATE service primitives

Generic name	Specific name	Parameters
TNMM-AUTHENTICATE	Indication	Result, reason
TNMM-AUTHENTICATE	Confirm	Result
TNMM-AUTHENTICATE	Request	Configure

The parameters used in the above primitives should be coded as follows:

- result =
 - success;
 - failure of MS authentication;
 - failure of SwMI authentication;
- reason =
 - authentication pending;
- configure =
 - authenticate SwMI now;
 - never mutually authenticate;
 - always mutually authenticate;
 - never authenticate during location update;
 - always authenticate during location update;
 - authenticate only in ITSI-Attach form of location update.

4.3.2 SCK transfer primitives

A service shall be provided to allow an application to receive new SCKs either on demand or initiated by the SwMI. The primitives required shall be as follows:

- TNMM-SCK indication shall be used to provide the MS application with the SCKN and SCK-VN of each key received.
- TNMM-SCK confirm shall be used by the MS application to confirm that the key information received is acceptable, or provide the reject reasons if not.
- TNMM-SCK request shall be used to request the distribution of a new static cipher key. It shall contain the number (of 32 possible values) of each SCK requested. More than one SCK may be requested in one transaction.

Table 4: TNMM SCK service primitives

Generic name	Specific name	Parameters
TNMM-SCK	Indication	SCKN, SCK-VN, GTSI
TNMM-SCK	Confirm	Result
TNMM-SCK	Request	SCKN

The parameters used in the above primitives should be coded as follows:

- result =
 - SCK received successfully;
 - SCK failed to decrypt;
 - SwMI Unable to provide SCK;
- SCKN =
 - SCK number 1;
 - SCK number 2;

- SCK number 3;
- ...;
- SCK number 32;
- SCK-VN =
 - 0;
 - ...;
 - $2^{16}-1$.

4.3.3 GCK transfer primitives

A service shall be provided to allow an application to receive new GCKs either on demand or initiated by the SwMI. The primitives required shall be as follows:

- TNMM-GCK indication shall be used to provide the MS application with the GCKN, optionally the GTSI, and GCK-VN of the key received.
- TNMM-GCK confirm shall be used by the MS application to confirm that the key information received is acceptable, or provide the reject reasons if not.
- TNMM-GCK request shall be used to request the distribution of a new GCK. It shall contain either the address (GTSI) for the GCK requested or the GCKN for the GCK requested.

Table 5: TNMM GCK service primitives

Generic name	Specific name	Parameters
TNMM-GCK	Indication	GTSI, GCK-VN, GCKN
TNMM-GCK	Confirm	Result
TNMM-GCK	Request	GTSI, GCKN

The parameters used in the above primitives should be coded as follows:

- result =
 - GCK received successfully;
 - GCK failed to decrypt;
 - SwMI Unable to provide GCK;
- GTSI =
 - 1;
 - 2;
 - ...;
 - $2^{48}-2$;

NOTE: The SSI part of GTSI cannot take the values "000000₁₆" and "FFFFFF₁₆".

- GCK-VN =
 - 0;
 - ...;
 - $2^{16}-1$.

- GCKN =
 - 0;
 - 1;
 - 2;
 - ...;
 - $2^{16}-1$.

4.3.4 GSKO transfer primitives

A service shall be provided to allow an application to receive new GSKO either on demand or initiated by the SwMI. The primitives required shall be as follows:

- TNMM-GSKO indication shall be used to provide the MS application with the GSKO-VN of each key received.
- TNMM-GSKO confirm shall be used by the MS application to confirm that the key information received is acceptable, or provide the reject reasons if not.
- TNMM-GSKO request shall be used to request the distribution of a new Group Session Key for OTAR.

Table 6: TNMM GSKO service primitives

Generic name	Specific name	Parameters
TNMM-GSKO	Indication	GSKO-VN
TNMM-GSKO	Confirm	Result
TNMM-GSKO	Request	

The parameters used in the above primitives should be coded as follows:

result =

GSKO received successfully;

GSKO failed to decrypt;

SwMI Unable to provide GSKO;

GSKO-VN =

0;

...;

$2^{16}-1$.

4.4 Authentication protocol

4.4.1 Authentication state transitions

Figures 16 and 17 give an overview of the received PDUs that result in a change of authentication state.

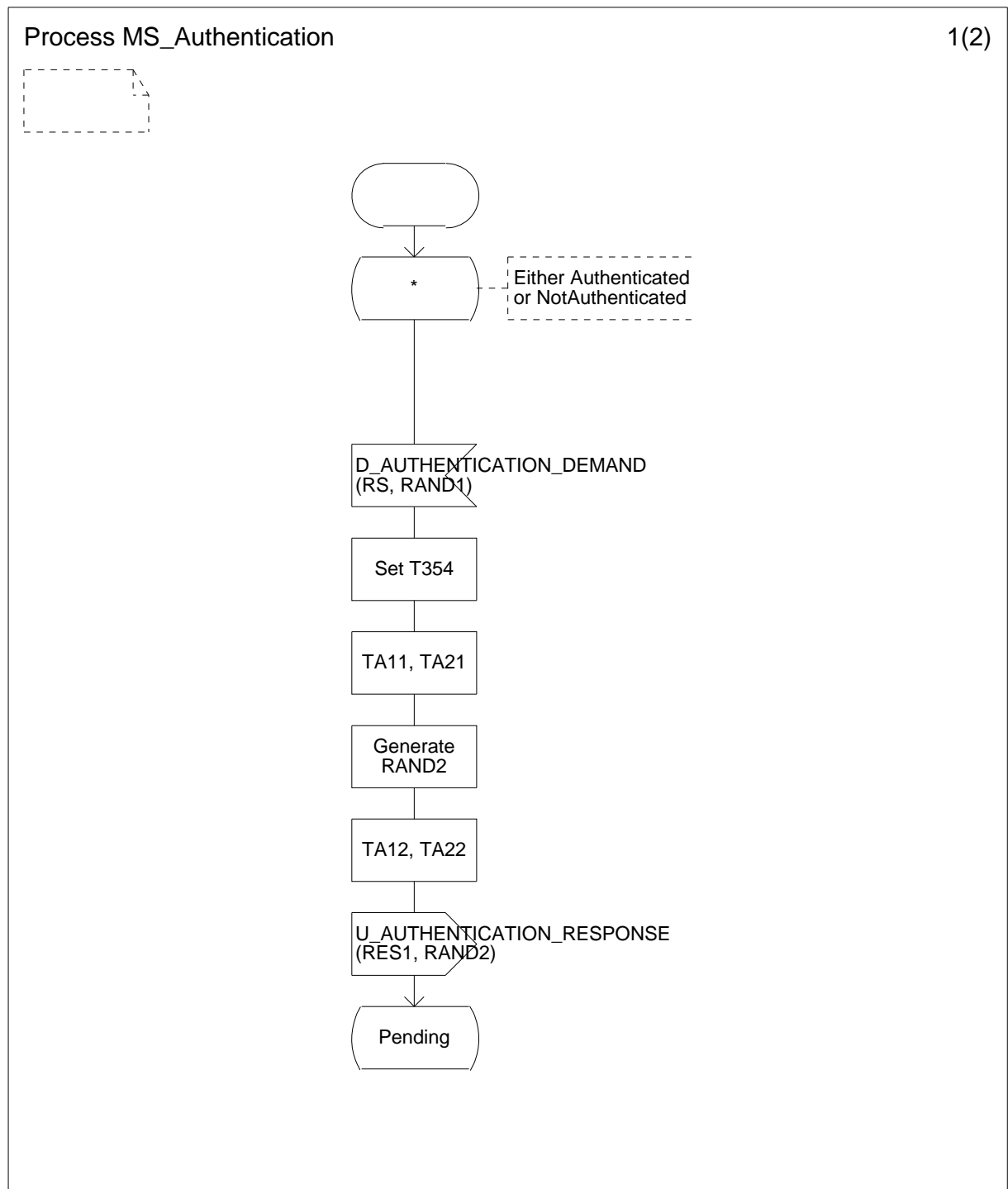
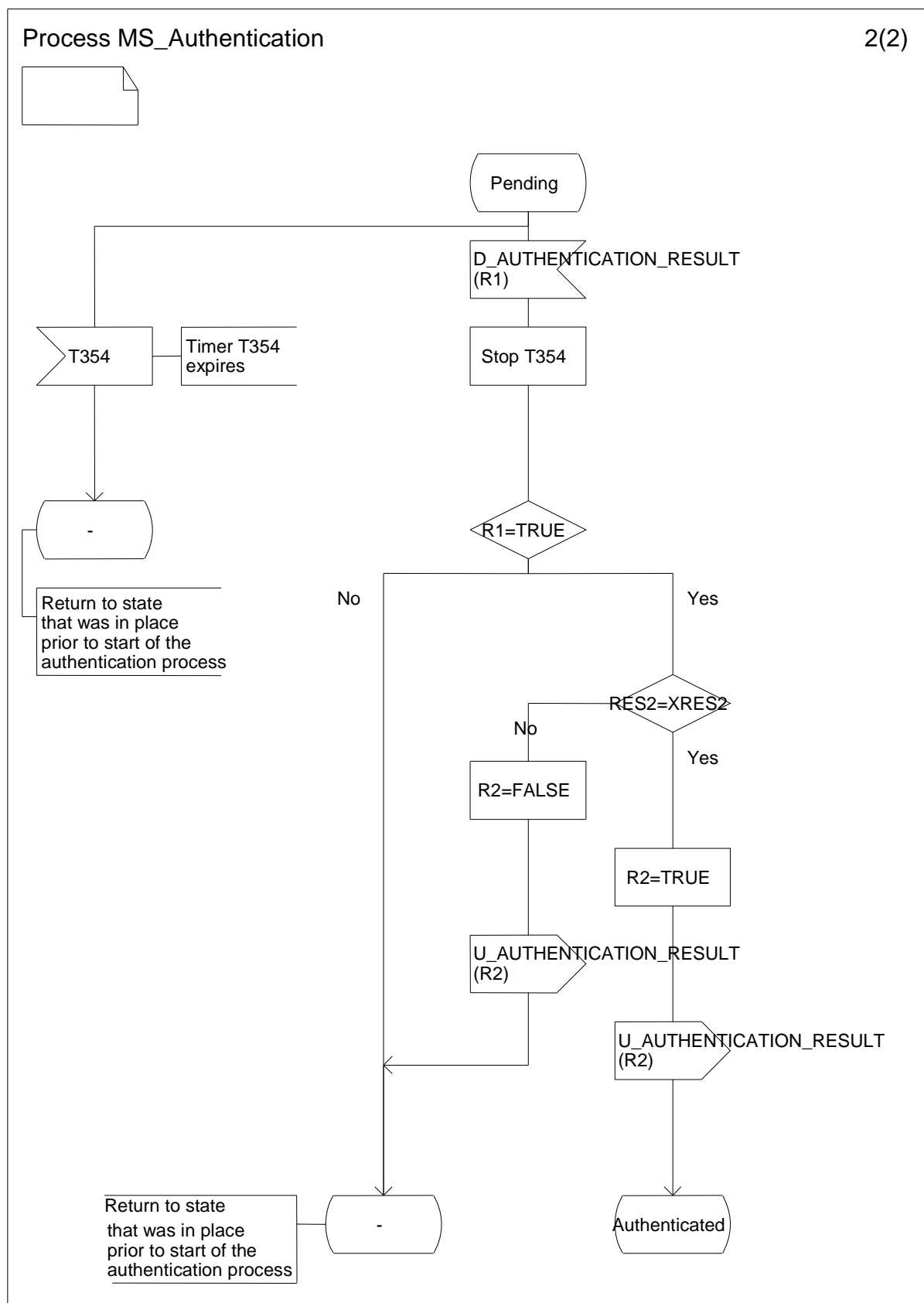

Figure 16: SDL process diagram for SwMI initiated authentication made mutual by MS (page 1 of 2)



Authenticated = The MS has performed a successful authentication sequence.

Not authenticated = The MS has not yet been authenticated.

Pending = An authentication sequence has begun and not yet completed. If a new authentication is started then any pending authentication shall be abandoned.

Figure 17: SDL process diagram for SwMI initiated authentication made mutual by MS (page 2 of 2)

4.4.2 Authentication protocol sequences and operations

The air interface authentication protocol shall use the Mobility Management (MM) service of layer 3 in the TETRA protocol stack (see EN 300 392-2 [2], clause 14).

The following statements outline the dynamic requirements described by the protocol:

- if the authentication procedure fails to complete within time T354 the authenticating parties shall each revert to the same authentication state and set of encryption keys that were in place prior to the start of the authentication procedure;
- if DCK is to be used for AI encryption then CCK shall be used to generate ESI and MGCK where used (class 3 cell);
- if authentication is performed during a U-PLANE transmission the DCK change shall take place according to the criteria given in clause 4.5.5.1;
- authentication should be carried out using a previously established encryption key where possible (changeover of DCK may be applied at the points shown in the MSCs of this clause);
- the encryption state (clear or encrypted) shall not be changed during location update signalling. The change (if required) shall be made when both the authentication sequence has been completed and the location update has been accepted.

An authentication exchange can be requested, either explicitly or as part of the registration procedure and can be initiated by either the MS or SwMI. The initiating side shall send an "AUTHENTICATION DEMAND" PDU that shall always be answered by the other side with either an "AUTHENTICATION RESPONSE" or an "AUTHENTICATION REJECT" PDU. Success or failure of the authentication shall be communicated by a specific "AUTHENTICATION RESULT" PDU. If an MS is not currently involved in an authentication exchange it shall ignore any authentication results or rejections addressed to the MS.

The recipient of the first authentication demand may instigate mutual authentication by use of the mutual authentication indicator, and by sending its challenge together with the response to the first challenge. In this case, the response to this second challenge shall be sent together with the result of the first challenge. This mechanism saves signalling, as only one random seed RS is required, and the functions can be combined in PDUs requiring fewer transmissions at the air interface.

If the mutual authentication flag is set then the recipient knows to use DCK1 and DCK2 as input to TB4. If the mutual authentication flag is not set then TB4 is run with the "other" DCKx set to zero as stated as clause 4.2.1. Thus, if "MS to SwMI" authentication is followed at some later time by "SwMI to MS" authentication, the first exchange will produce a DCK with DCK2 set to zero, and the second exchange will produce a DCK with DCK1 set to zero. If the mutual authentication flag is used and the authentication made mutual, as described above and in clause 4.1.4, then DCK is an algorithmic combination of DCK1 and DCK2.

After a successful authentication exchange, both MS and SwMI shall replace both parts of the derived cipher key, DCK1 or DCK2, with the newly calculated values, and the derived cipher key DCK accordingly.

On sending of an authentication challenge the MS shall start timer T354. On receipt of an authentication challenge the MS shall start timer T354. If timer T351 is running it shall be stopped and T354 shall apply.

When T354 expires the MS and SwMI shall revert to the state that existed prior to the initiating authentication challenge.

NOTE 1: Repeated expiry of T354 may be used as a reason to select an alternative cell.

The behaviour described in this clause shall apply whenever authentication takes place, i.e. standalone, at registration, at location update.

If the MS receives a D-AUTHENTICATION RESULT PDU containing a false value of R1 the MS MM may send the MS MLE an MLE-UPDATE request primitive with reject cause "LA rejection" so that the MS MLE initiates cell reselection as defined in EN 300 392-2 [2], clause 18.3.4.7. If the MS decides to initiate cell selection at this stage, it shall treat this as though it received a D-LOCATION UPDATE REJECT PDU with reject cause "Authentication failure (system rejection)", and shall count this towards the maximum permitted number of system rejections, as described in EN 300 392-2 [2], clause 16.4.1.1.

NOTE 2: If the MS does not leave the current cell when it receives a false value of R1, it may subsequently be instructed to leave the cell by receipt of a D-LOCATION UPDATE REJECT PDU.

If the MS receives an incorrect RES2 value in a D-AUTHENTICATION RESPONSE PDU or a D-AUTHENTICATION RESULT PDU, the MS MM service shall send the SwMI a U-AUTHENTICATION RESULT PDU with R2 set to false. The MS shall send the MS MLE service an MLE-UPDATE request primitive with reject cause "LA rejection" so that the MS MLE initiates cell reselection as defined in EN 300 392-2 [2], clause 18.3.4.7. The MS shall treat this as though it received a D-LOCATION UPDATE REJECT PDU with reject cause "Authentication failure (system rejection)", and shall count this towards the maximum permitted number of system rejections, as described in EN 300 392-2 [2], clause 16.4.1.1.

If the MS sends the SwMI a U-AUTHENTICATION DEMAND PDU and the MS receives in reply a D-AUTHENTICATION REJECT PDU, the MS MM may send the MS MLE an MLE-UPDATE request primitive with reject cause "LA rejection" so that the MS MLE initiates cell reselection as defined in EN 300 392-2 [2], clause 18.3.4.7.

If the MS attempts to make an authentication challenge mutual by sending the SwMI a U-AUTHENTICATION RESPONSE PDU that includes a RAND2 information element, and if the MS receives in reply a D-AUTHENTICATION RESULT PDU that does not contain a RES2 information element the MS MM may send the MS MLE an MLE-UPDATE request primitive with reject cause "LA rejection" so that the MS MLE initiates cell reselection as defined in EN 300 392-2 [2], clause 18.3.4.7.

4.4.2.1 MSCs for authentication

This clause presents Message Sequence Charts (MSCs) for the authentication protocol to enable the mechanisms described in clause 4.1.

Table 6a: Authentication protocol MSC locations

Case	Title	Figure number
1	SwMI authenticates MS	18
2	MS authenticates SwMI	19
3	Authentication initiated by SwMI and made mutual by the MS	20
4	Authentication initiated by MS and made mutual by the SwMI	21
5	SwMI rejects authentication demand from MS	22
6	MS rejects authentication demand from SwMI	23

NOTE: In the MSCs where the timer T354 is explicitly shown it is shown as being terminated by the MS-MM process and not as having expired.

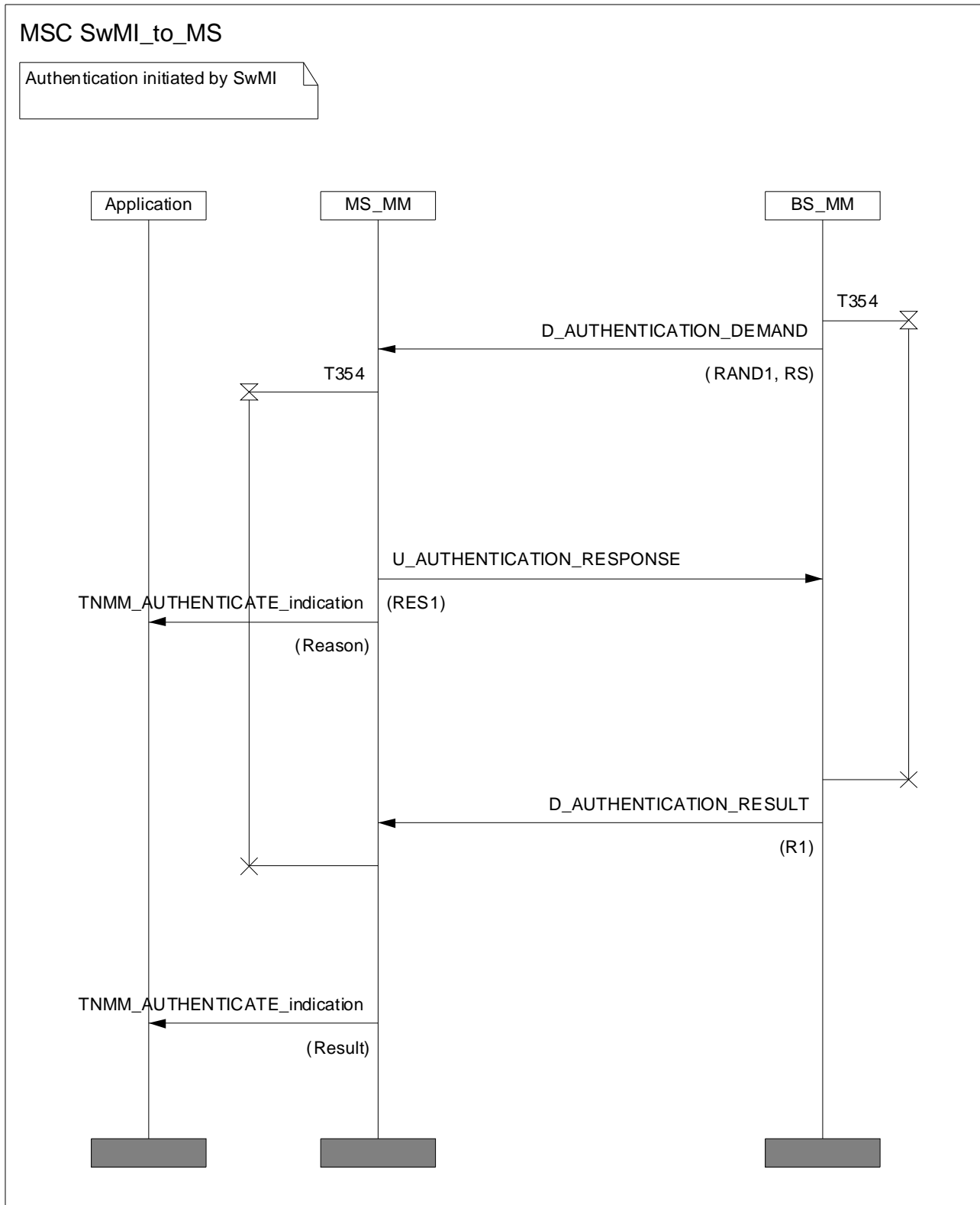

Figure 18: Authentication of MS by SwMI

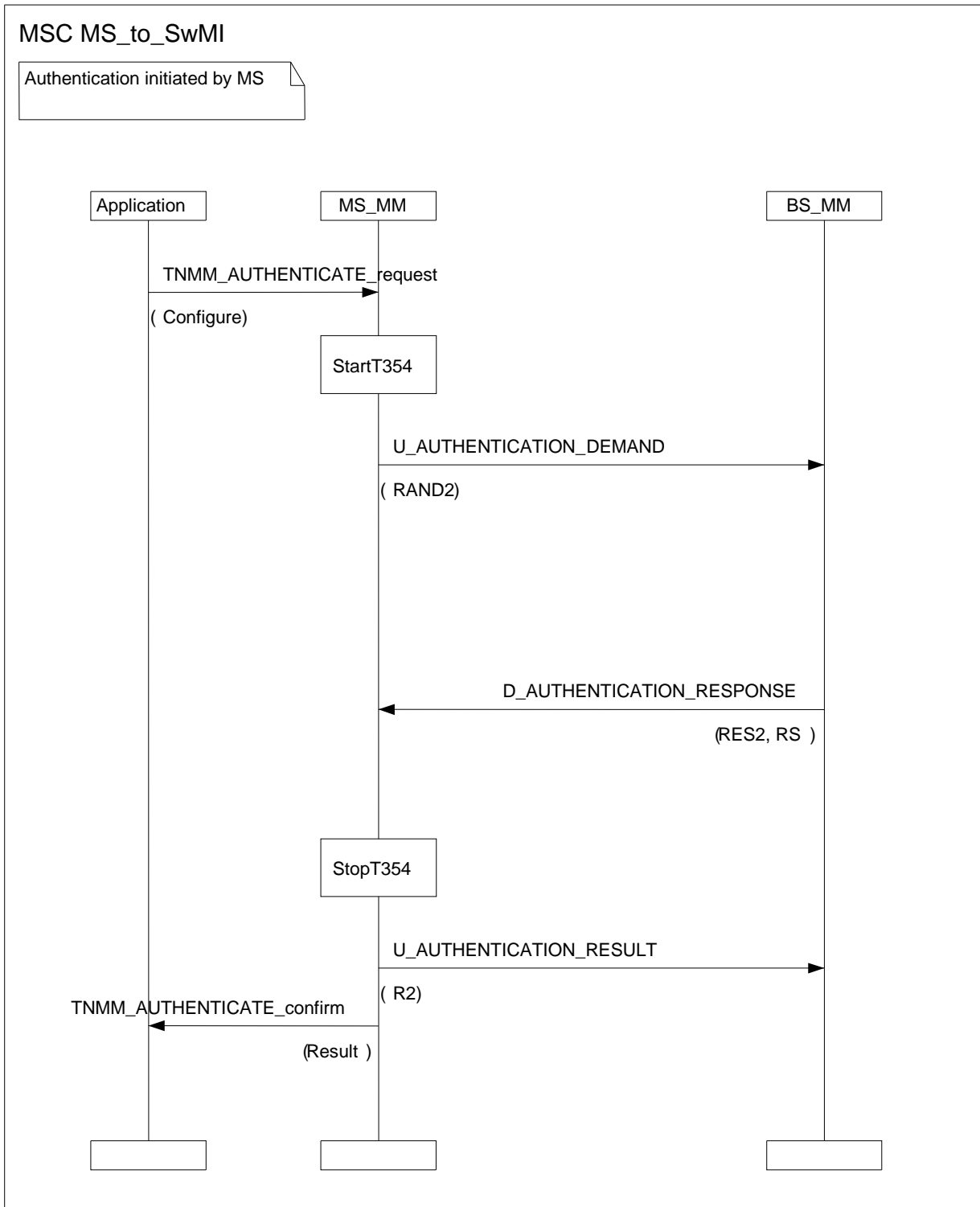

Figure 19: Authentication of the SwMI by the MS

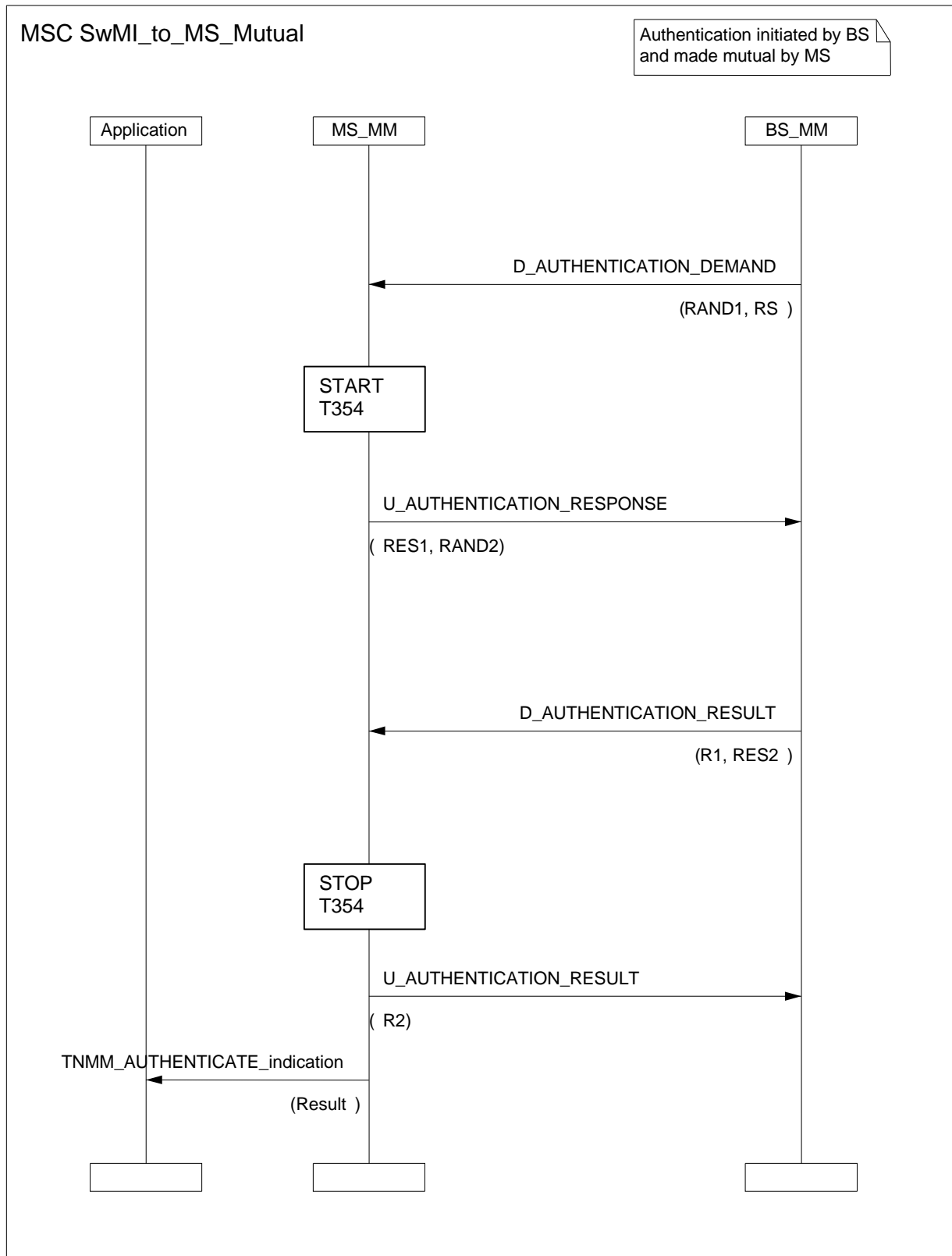

Figure 20: Authentication initiated by SwMI and made mutual by the MS

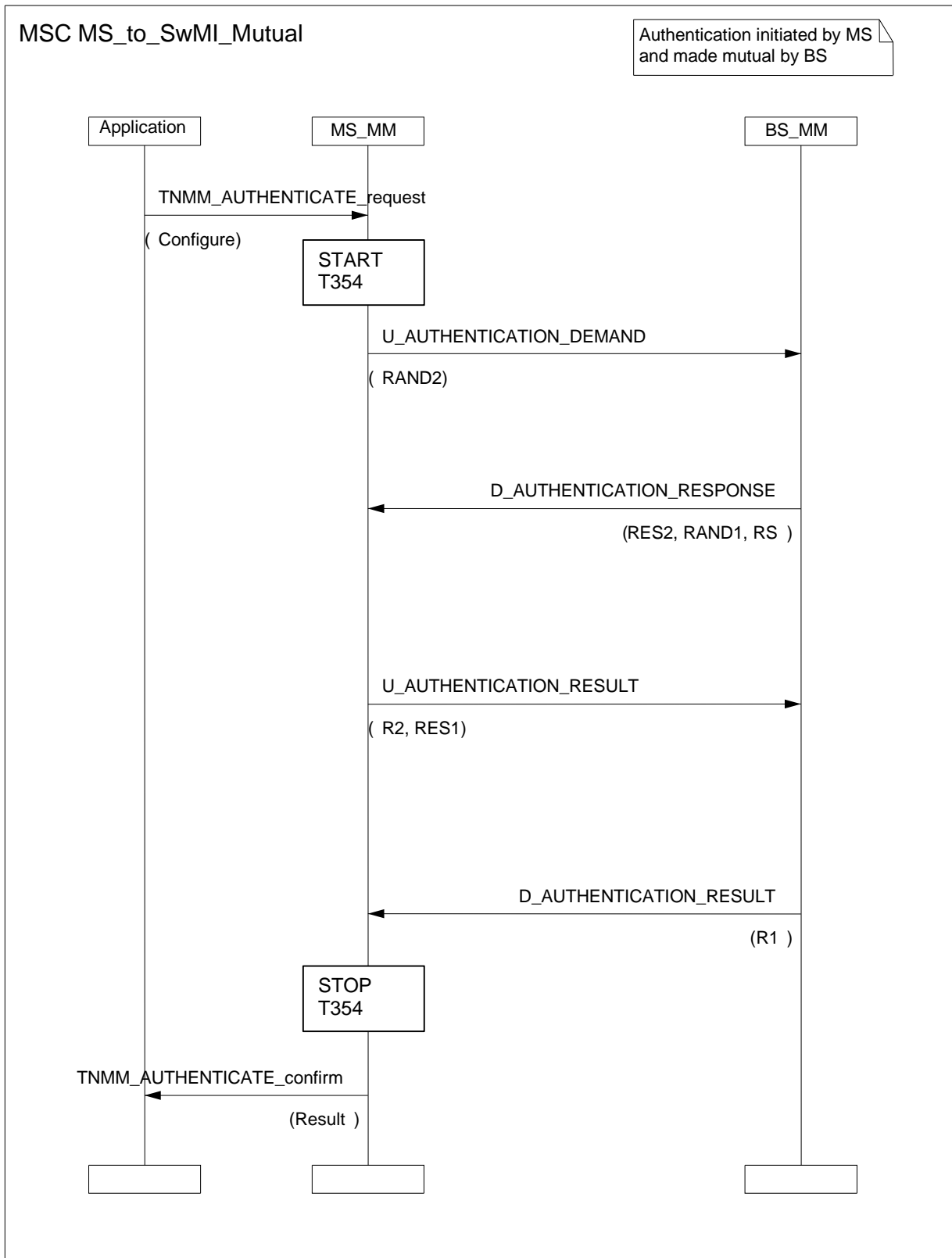

Figure 21: Authentication initiated by MS and made mutual by the SwMI

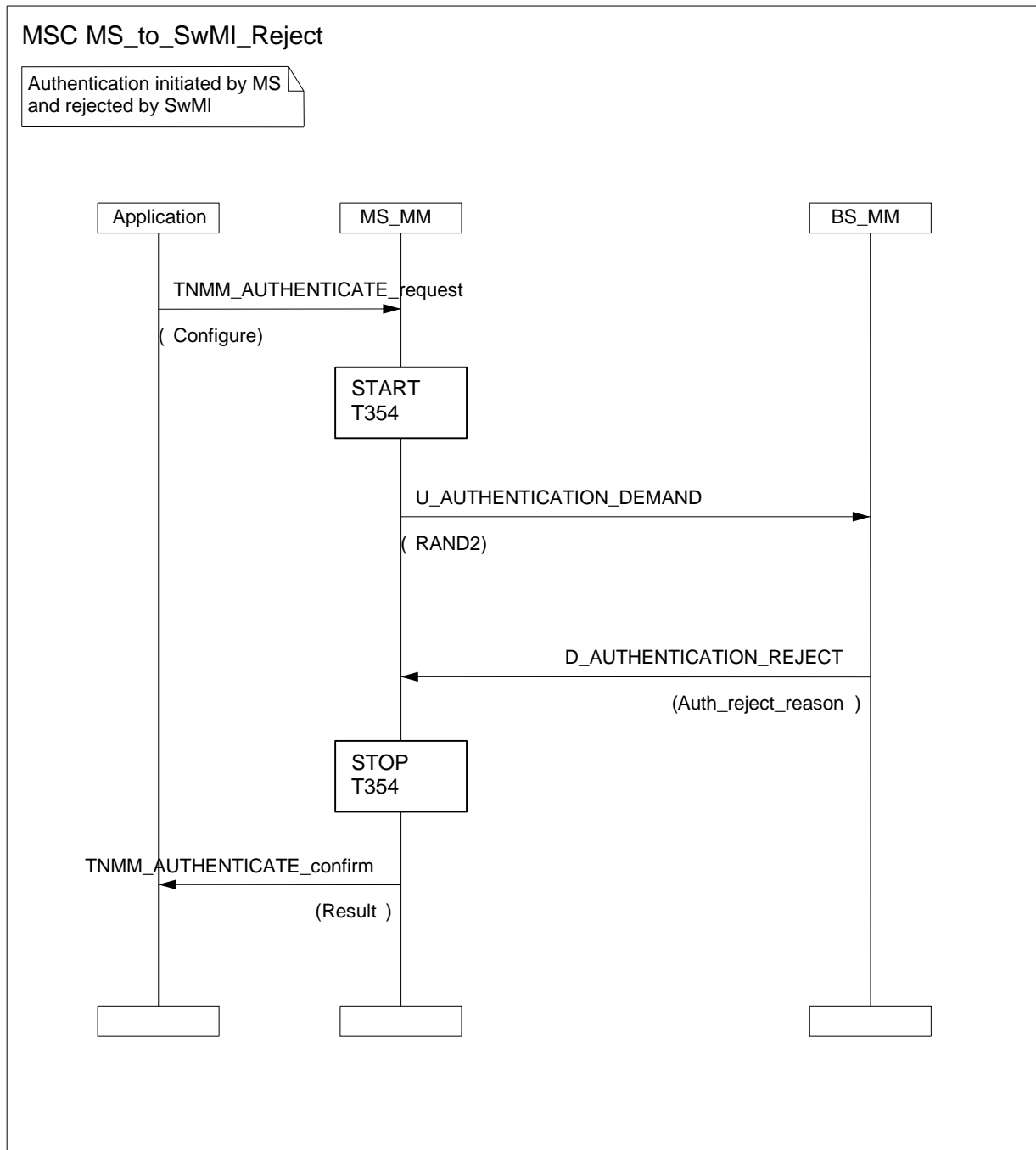

Figure 22: Authentication initiated by MS and rejected by SwMI

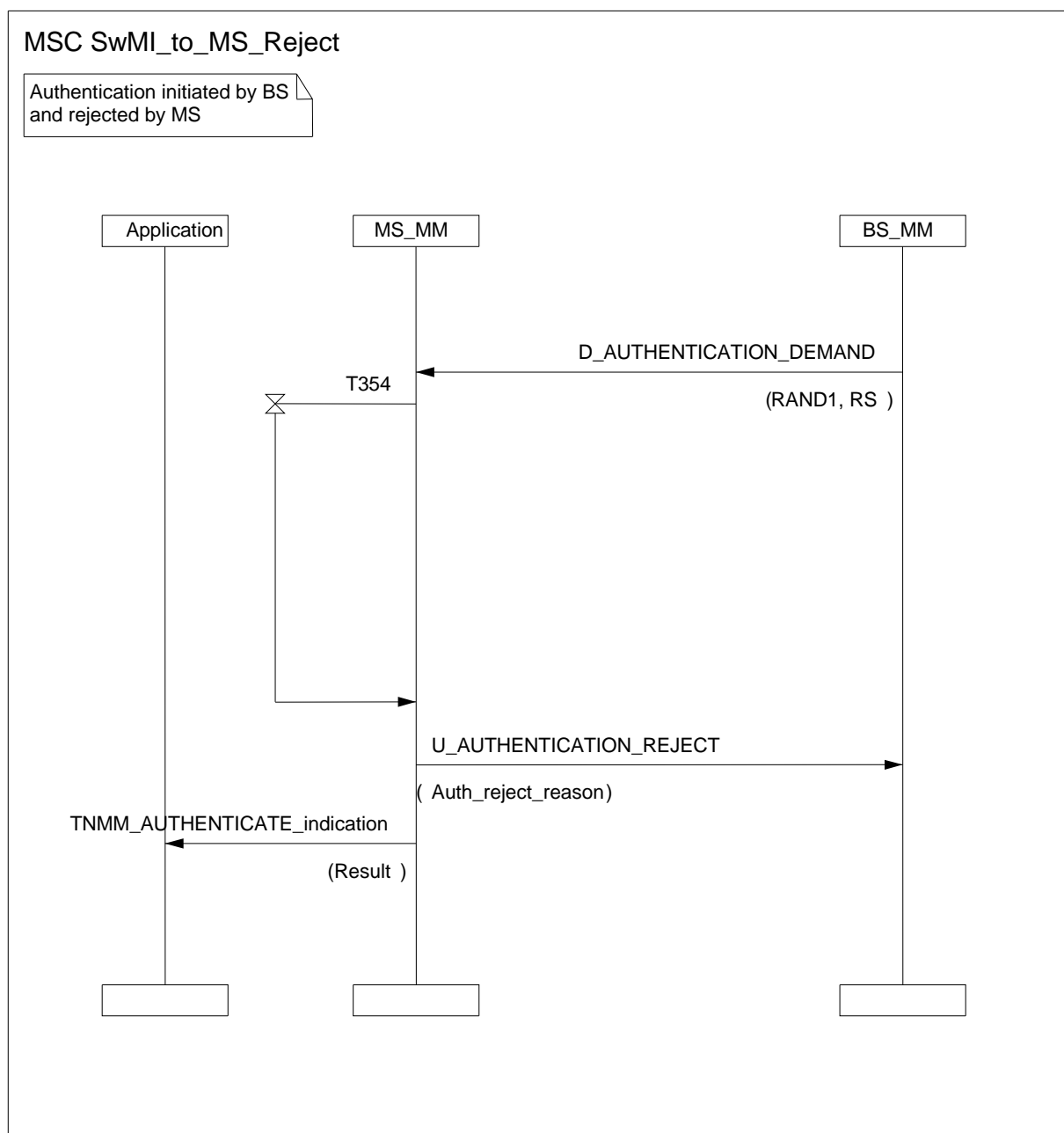

Figure 23: Authentication initiated by SwMI and rejected by MS

4.4.2.2 MSCs for authentication Type-3 element

The type-3 PDU elements Authentication uplink and Authentication downlink contained in the U-LOCATION UPDATE DEMAND and D-LOCATION UPDATE ACCEPT PDUs respectively allow authentication and CK key exchange to be initiated by the MS. The SwMI then is able to provide the CK for the current LA (of which the serving cell is a member) to the registering MS.

The CK key being requested in the Authentication uplink shall be qualified by the security class field in the ciphering parameters, i.e.:

- if the MS requests the CK in the Authentication uplink, and the ciphering parameters indicate security class 2, then the SwMI shall infer that the MS is requesting the SCK in current use;
- if the MS requests the CK in the Authentication uplink, and the ciphering parameters indicate security class 3, then the SwMI shall infer that the MS is requesting the CCK.

When the SwMI provides CK information in the Authentication downlink, the SwMI may provide additional CK material as well as that requested in the Authentication uplink, i.e.:

- if the MS requests the CCK in the Authentication uplink, the SwMI may provide the CCK and the SCK in the Authentication downlink;
- if the MS requests the SCK in the Authentication uplink, the SwMI may provide the SCK and the CCK in the Authentication downlink.

The Authentication downlink may also contain a demand for the MS to provide its TEI. It is recommended that this option is used only if encryption is applied (i.e. in class 2 and class 3 systems).

This clause shows the message sequence charts for the following cases:

- MS initiated location update request with embedded CK request and SwMI CK provision (figure 24);
- MS initiated location update request with embedded Authentication challenge (figure 25);
- SwMI initiated TEI provision request (figure 26).

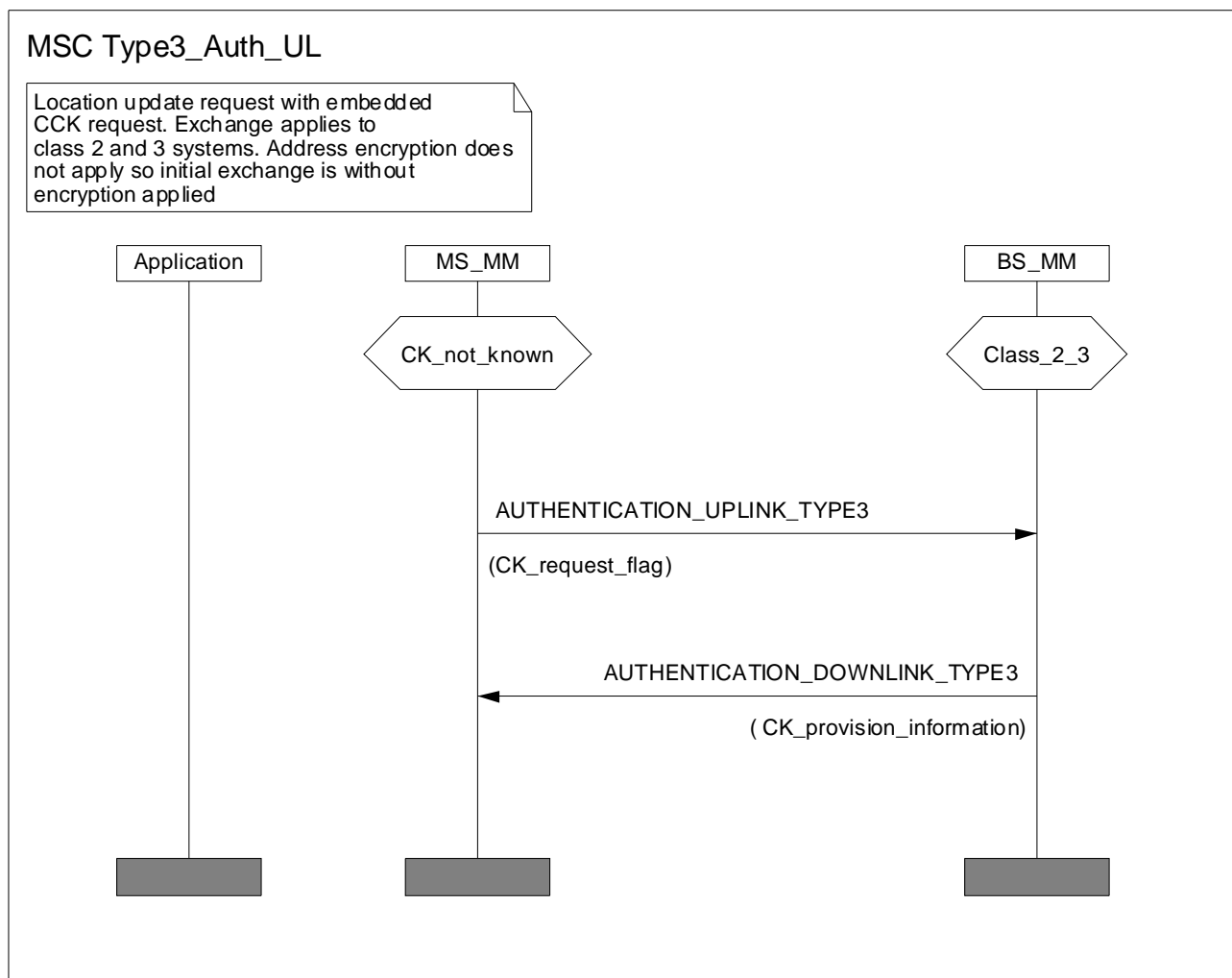

Figure 24: CK provision during location update

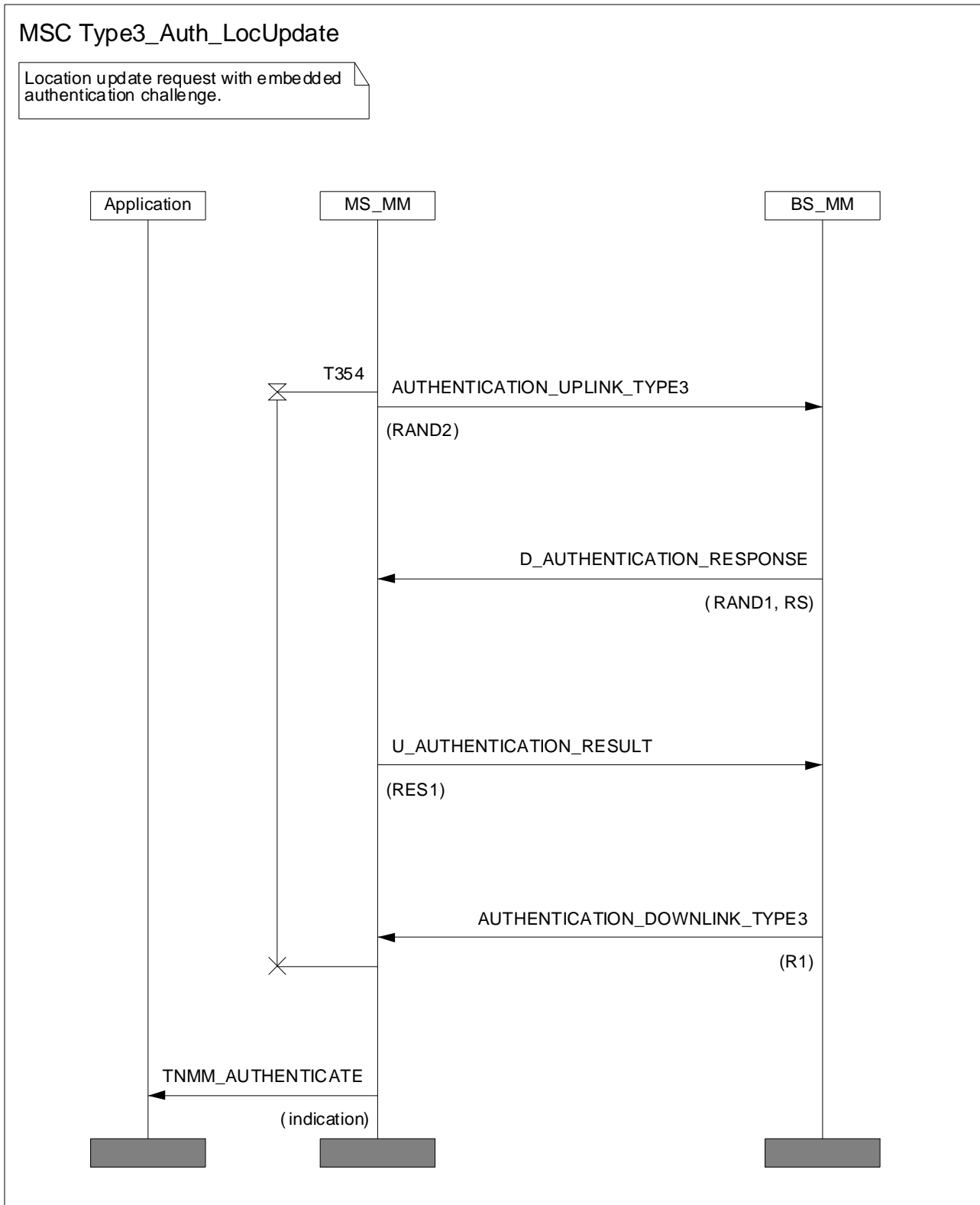
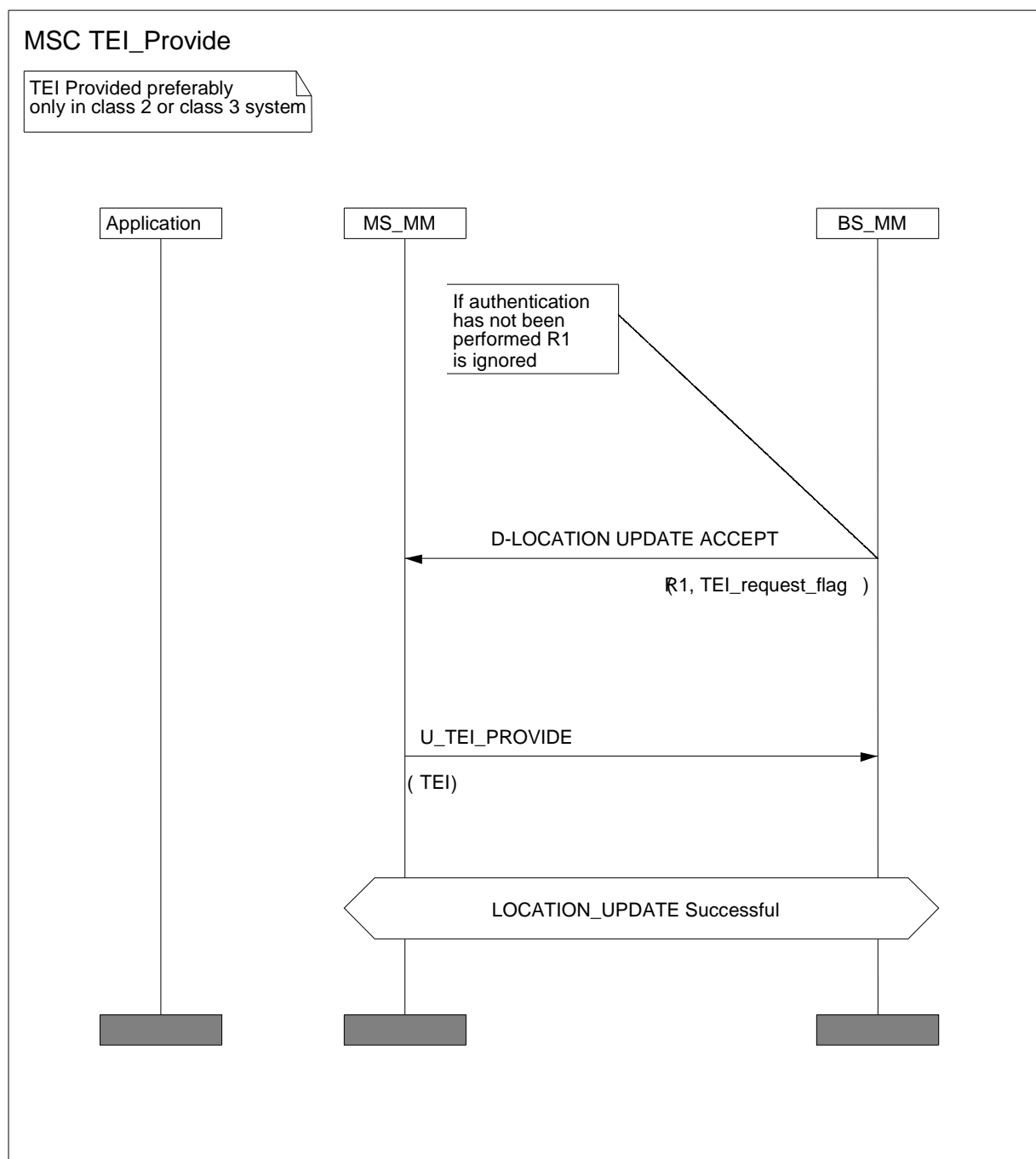

Figure 25: MS initiated authentication during location update



NOTE: If D-LOCATION UPDATE ACCEPT is received R1 may be ignored.

Figure 26: TEI Provision in class 2 or 3 system

4.4.2.3 Control of authentication timer T354 at MS

The timer shall be started under the following conditions:

- on sending of U-AUTHENTICATION DEMAND;
- on receipt of D-AUTHENTICATION DEMAND; and
- on sending of U-LOCATION UPDATE DEMAND containing an Authentication challenge in the type-3 element "Authentication uplink". In this case the value of T354 shall be the same as T351 and only one of these timers needs to be started.

The timer shall be stopped (cancelled) under the following conditions:

- on receipt of D-AUTHENTICATION RESULT for SwMI initiated unilateral authentication, and for authentication initiated by the MS but made mutual by the SwMI;
- on sending of U-AUTHENTICATION RESULT for MS initiated unilateral authentication, and for authentication initiated by the SwMI but made mutual by the MS;
- on sending of U-AUTHENTICATION REJECT;
- on receipt of D-AUTHENTICATION REJECT;
- on receipt of D-LOCATION UPDATE REJECT; and
- on receipt of D-LOCATION UPDATE ACCEPT containing the type-3 element "Authentication downlink".

NOTE: The behaviour of T354 in the SwMI has to be set to ensure correct MS operation.

4.5 OTAR protocols

4.5.1 CCK delivery - protocol functions

CCK is a cipher key linked to the use of Air Interface encryption with DCK. This clause describes the key management protocols used to support the algorithms and mechanisms described in clause 4.2.3. CCK is required prior to enabling encrypted air interface services on a cell as it is linked to the ESI mechanism used for layer 2 addressing (see clause 4.2.6).

CCK shall be delivered over the air interface using the mechanisms and protocols described in this clause, and by the registration and authentication procedures defined in clause 4.4.2.

When scanning a cell prior to registration an MS shall receive the CCK-id and LA-id of the CCK in use on that cell in the SYSINFO broadcast. If the CCK so identified is not known to the MS it shall request the CCK either through its current serving cell or at the new cell using the protocols defined in the present document.

The SwMI can deliver to all registered MSs a CCK for future use.

When delivering a CCK the SwMI shall indicate the Las for which the CCK is valid. This may be in the form of a list of Las, a bit mask of LA identities, a range of LA identities, or it may be applied to all Las. When sending CCK by a list the list shall include the corresponding LA identity.

The LA selector and mask mechanism is intended to find if the CCK applies to the current LA. To achieve this the mask is logically ANDed with the LA-id received from the SwMI in the broadcast parameters. If the result is equal to the selector, then CCK is valid for the current LA-id.

The CCK may be provided explicitly by the SwMI using the "D-OTAR CCK Provide" PDU, the "D-OTAR NEWCELL" PDU, or may be provided during the registration procedure using the MM type 3 element "Authentication downlink" contained in "D-LOCATION UPDATE ACCEPT PDU".

An MS may explicitly request a CCK from the SwMI using the "U-OTAR CCK Demand" PDU, or the "U-OTAR PREPARE PDU", or CCK may be requested during the registration procedure using the MM type 3 element "Authentication uplink" contained in "U-LOCATION UPDATE DEMAND" PDU.

When an MS is authenticated and requests CCK within the location update sequence, then the DCK that is generated in the authentication exchange shall be used to seal the provided CCK(s).

4.5.1.1 SwMI-initiated CCK provision

The scenario in figure 27 shows how the SwMI can distribute new CCK information. The SwMI can initiate CCK provision at any time when the MS is registered on the cell. The SwMI may provide the CCK of the current cell or the CCK of any other cell. The Las for which the CCK is valid are always identified in the D-OTAR CCK Provide PDU in the CCK information element.

The normal message sequence in this case shall be according to figure 27.

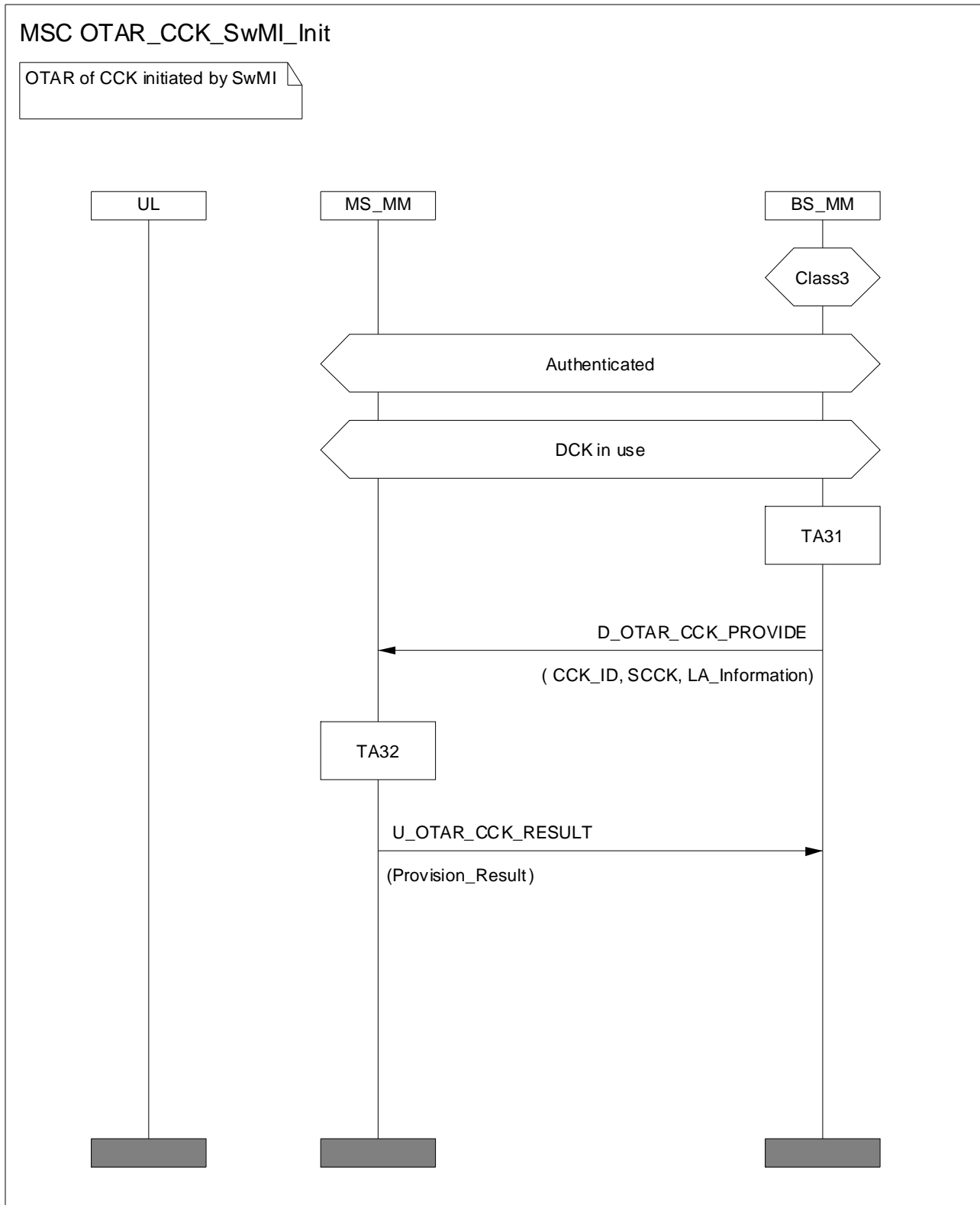

Figure 27: SwMI Initiated CCK provision

4.5.1.2 MS-initiated CCK provision with U-OTAR CCK demand

The normal message sequence in this case shall be according to figure 28.

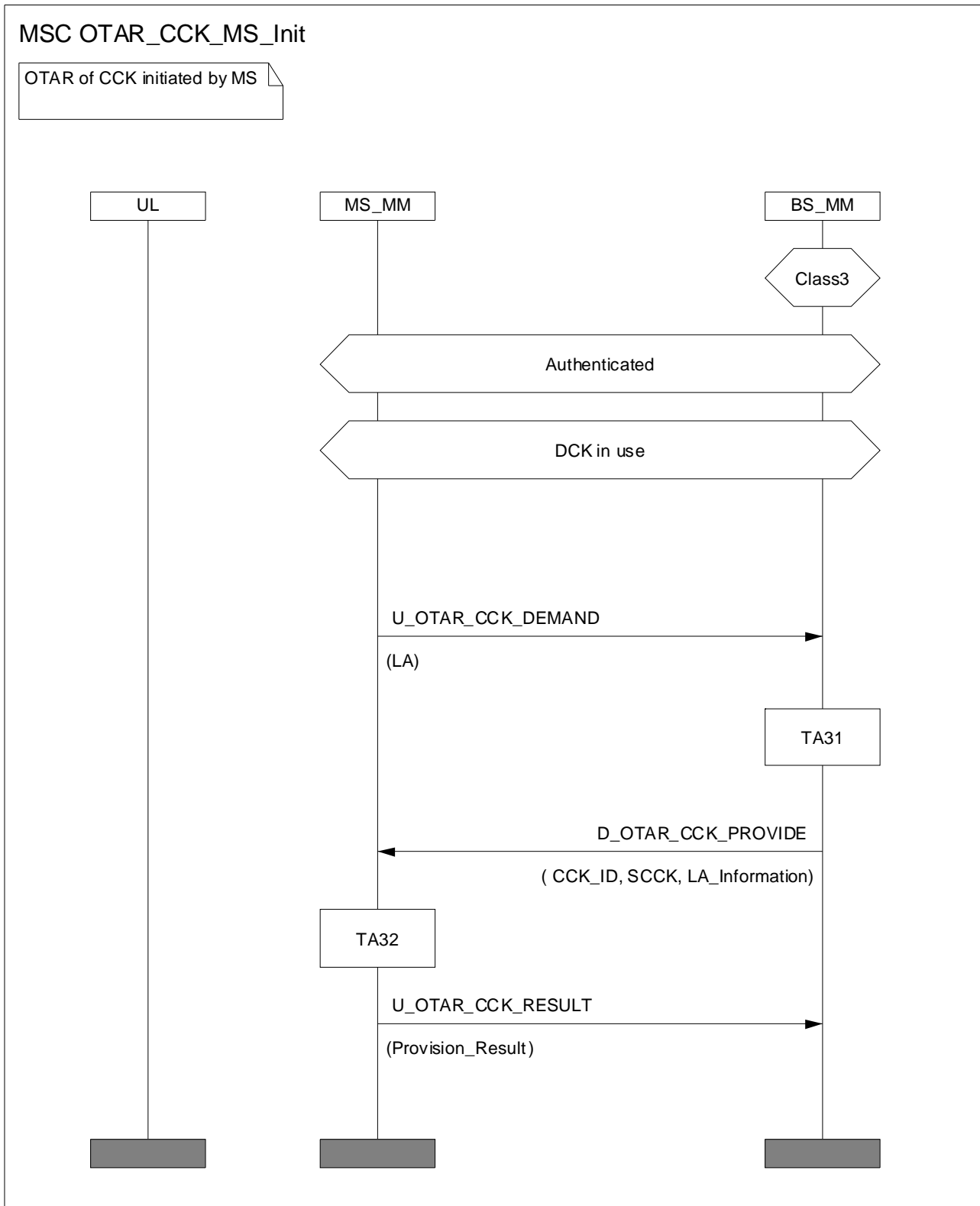

Figure 28: MS-initiated CCK provision

4.5.1.3 MS-initiated CCK provision with announced cell reselection

Whilst the primary use of the U-PREPARE PDU is to allow call restoration when moving between cells it may also be used by an MS to request the CCK for the new cell, or to forward register to a new cell using the announced type 1 cell re-selection mechanism. In order to support encrypted cell change to class 3 cells the U-PREPARE PDU may carry an U-OTAR CCK Demand PDU.

For announced type 1 cell reselection where the CCK of the new cell is required two options exist:

- 1) MS required to register:
 - the CK request for CCK information shall be sent in the U-LOCATION UPDATE DEMAND PDU carried by the U-PREPARE PDU;
- 2) MS not required to register:
 - the CCK request shall be sent in the U-OTAR CCK Demand PDU carried by the U-PREPARE PDU.

Case 1: New cell is in same LA and same registered area.

MS shall assume that the current values of CCK and DCK will be valid on new cell. U-PREPARE shall contain no MM PDUs.

Case 2: New cell is in different LA but same registered area.

Before roaming to a new cell the MS may request the CCK of the new cell from its current serving cell by sending U-OTAR CCK Demand with LA = LA of new cell. The U-OTAR CCK Demand PDU may be sent in the U-PREPARE PDU, in case MS is allowed to make the announced cell re-selection. The MS shall assume that DCK is valid in the new cell.

The SwMI shall supply the CCK of the requested LA using the D-OTAR CCK Provide PDU, which may be contained in the D-NEW CELL PDU, or it may inform the MS that provision is not possible.

Case 3: New cell is in different LA and different registered area.

For roaming to a cell of class 3 only using announced type 1 cell reselection, the MS shall send U-PREPARE with U-LOCATION UPDATE DEMAND and CK request for CCK information (if needed). If the new cell accepts the registration the SwMI shall ensure that the new serving cell, and the LA to which it belongs, has DCK of the roaming ITSI. The acceptance of the registration shall be contained in D-NEW-CELL containing D-LOCATION UPDATE ACCEPT and the CCK information of the new cell if requested.

For roaming to cells of class 3 only using announced type 2 cell reselection, the MS may send U-PREPARE with a CCK request (using U-OTAR CCK demand). If the new cell accepts the cell reselection the MS shall assume that the new serving cell, and the LA to which it belongs, has DCK of the roaming ITSI. The acceptance of the cell reselection shall be contained in D-NEW-CELL which, if requested, may contain the CCK information of the new cell (using D-OTAR CCK Provide).

See also clause 6.6 for change of class on moving between cells.

4.5.2 OTAR protocol functions - SCK

Up to seven SCKs may be distributed to the MS using the "D-OTAR SCK Provide" PDU. The provision may be started automatically by the SwMI or in response to a request from the MS using the "U-OTAR SCK Demand" PDU. The "SCK Use" element contained in each "SCK Key and Identifier" element within the PDU shall be used by the MS to determine whether a particular SCK is to be used in TMO or in DMO. The received value for the "SCK Use" element for a provided SCK shall overwrite any previous value held by the MS for that SCK. The most common cases are described by the MSCs and protocol description in the following clauses.

The MS shall send U-OTAR SCK RESULT according to the rules below.

- For MS requests and where the SwMI provides keys individually addressed to the MS a result shall always be sent (figure 29). When the SwMI responds individually addressed to the MS, the SwMI shall set Acknowledgement Flag to "Acknowledgement required" and Explicit Response to "Response to be sent whether state changed or not". However, the SwMI may provide keys addressed to a CMG GTSI, in response to an MS's individual request, in which case the MS shall interrogate the value of the Acknowledgement Flag to determine if an acknowledgement is required. If an acknowledgement is required the MS shall also interrogate the Explicit Response element in D-OTAR SCK PROVIDE. If set to "Response to be sent whether state changed or not" the MS shall respond whether the key provide changes the MS state or not; if set to "Response to be sent only if state of MS is changed", the MS shall only respond if the SwMI provides a key or key version that the MS did not previously have.
- For SwMI provision to a single MS a response shall always be sent (figure 30). The SwMI shall set Acknowledgement Flag to "Acknowledgement required" and Explicit Response to "Response to be sent whether state changed or not" when sending D-OTAR SCK Provide to a single MS.
- For SwMI provision to CMG GTSI (figure 31) the MS shall interrogate the value of the Acknowledgement Flag to determine if an acknowledgement is required. If an acknowledgement is required the MS shall also interrogate the Explicit Response element in D-OTAR SCK PROVIDE. If set to "Response to be sent whether state changed or not" the MS shall respond whether the key provide changes the MS state or not; if set to "Response to be sent only if state of MS is changed", the MS shall only respond if the SwMI provides a key or key version that the MS did not previously have.

4.5.2.1 MS requests provision of SCK(s)

The scenario in figure 29 shows the case where the MS requests provision of one or more SCKs in use on a system. The normal message sequence in this case shall be according to figure 29 that shows the invocation of algorithms at each of MS and BS to satisfy the request.

NOTE: Figure 29 shows individual encryption of SCK using KSO, however use of GSKO as shown in figure 31 is also possible for an individually or group addressed OTAR transmission.

The SwMI shall respond with the requested keys using the D-OTAR SCK Provide PDU, together with the SCKN and SCK-VN information. The MS shall respond and inform the SwMI of the success or failure of the OTAR using the U-OTAR SCK Result PDU I accordance with the rules mentioned in clause 4.5.2. In case of failure, it shall indicate the reason, which may include failure to decrypt the key, or SwMI provided the wrong key.

For individual provision of SCKs to an MS, the "max response timer value" element in the provision PDU shall be set to "0".

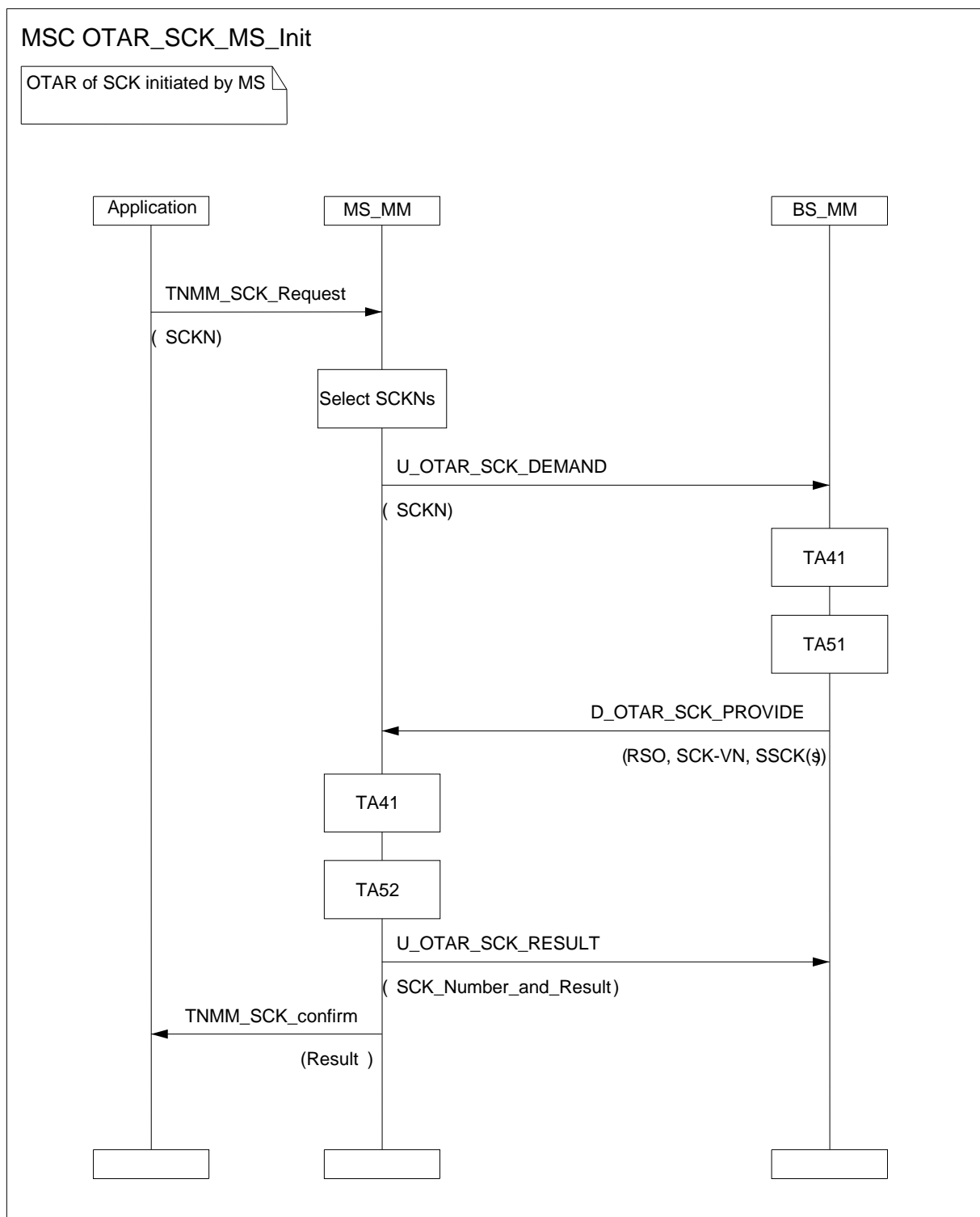

Figure 29: SCK delivery initiated by MS to an individual

4.5.2.2 SwMI provides SCK(s) to individual MS

The scenario in figure 30 shows the case where the SwMI provides one or more SCK(s) to an MS without the MS first requesting SCK provision. The SwMI may initiate this procedure at any time.

The normal message sequence in this case shall be according to figure 30.

NOTE: Figure 30 shows individual encryption of SCK using KSO, however use of GSKO as shown in figure 31 is also possible for an individually or group addressed OTAR transmission.

For individual provision of SCKs to an MS, the "max response timer value" element in the provision PDU shall be set to "0".

The MS shall respond and inform the SwMI of the success or failure of the OTAR using the U-OTAR SCK result PDU. The options are as detailed in clause 4.5.2.1.

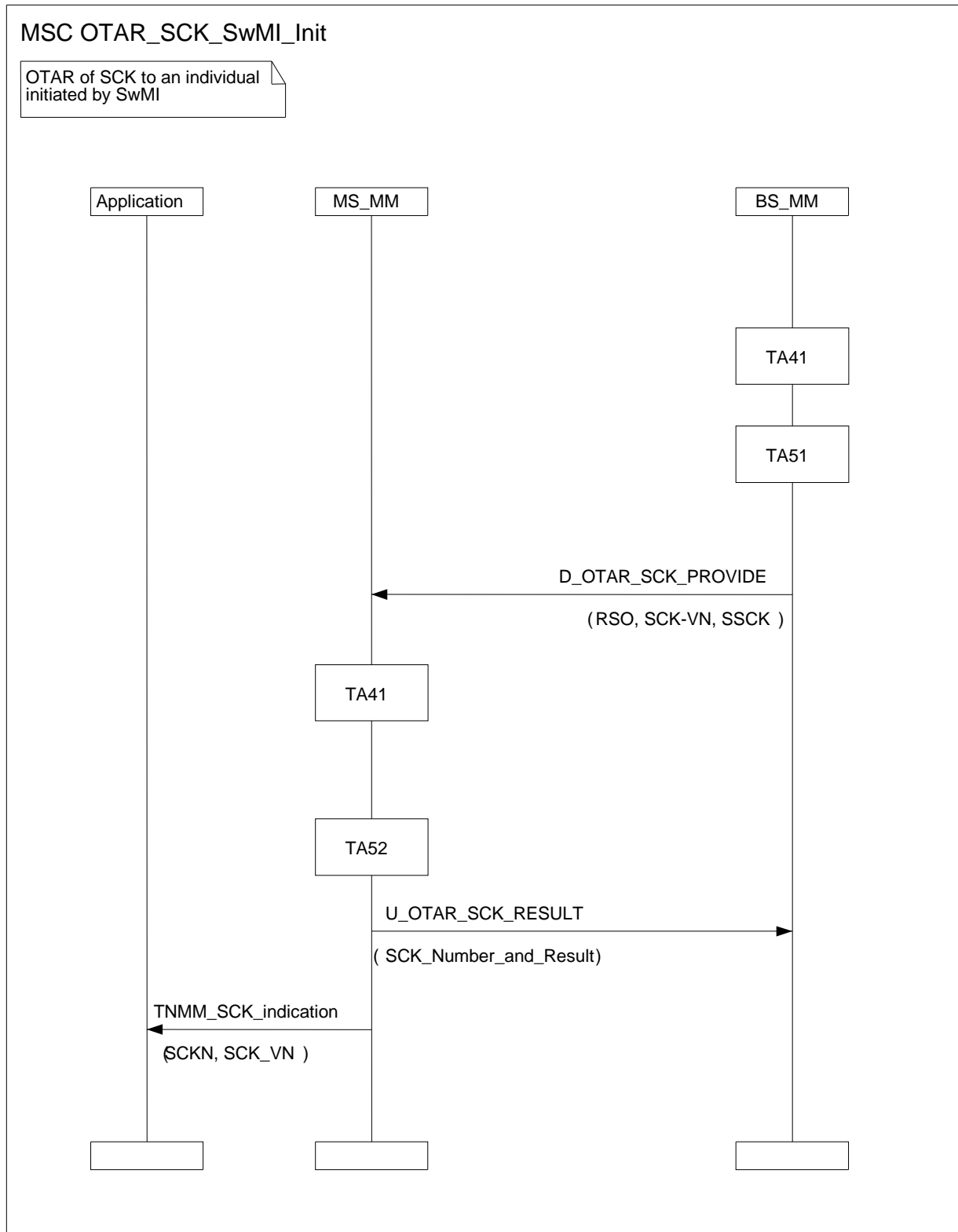

Figure 30: SCK delivery to an individual initiated by SwMI

4.5.2.3 SwMI provides SCK(s) to group of MSs

In the case of group addressed delivery of SCK, BS_MM and MS_MM shall not run TA41, but shall use EGSKO as input to TA51 and TA52. The U-OTAR SCK RESULT shall be sent from MS to SwMI following the expiry of random timer T371 provided that the Acknowledgement Flag is set to "Acknowledgement required" and either the SCK material provided is not currently stored in the MS, or the "explicit response" element of the D-OTAR SCK PROVIDE PDU is set to "Response to be sent whether state changed or not". T371 is started on reception of the D-OTAR SCK PROVIDE.

T371 is a timer with a value randomized to fall within the range 1 s and a maximum value that is signalled by the SwMI in the "max response timer value" element of the PDU. This maximum value may be up to 65 535 s (18,2 hours). The MS shall select a value in this range when setting T371. When T371 expires the MS shall wait a further random number of random access signalling slots before sending the U-OTAR SCK RESULT PDU. The procedure for randomly selecting the signalling slot shall follow the procedure for "Choosing from a new access frame" as defined in EN 300 392-2 [2], clause 23.5.1.4.6. If the MS needs to leave the SwMI by sending ITSI-Detach signalling the MS shall consider T371 to have terminated and shall send the U-OTAR SCK RESULT PDU before detaching from the SwMI.

The scenario in figure 31 shows the case where the SwMI provides one or more SCK(s) to a group of MSs identified by GTSI. The SwMI may initiate this procedure at any time.

The normal message sequence in this case shall be according to figure 31.

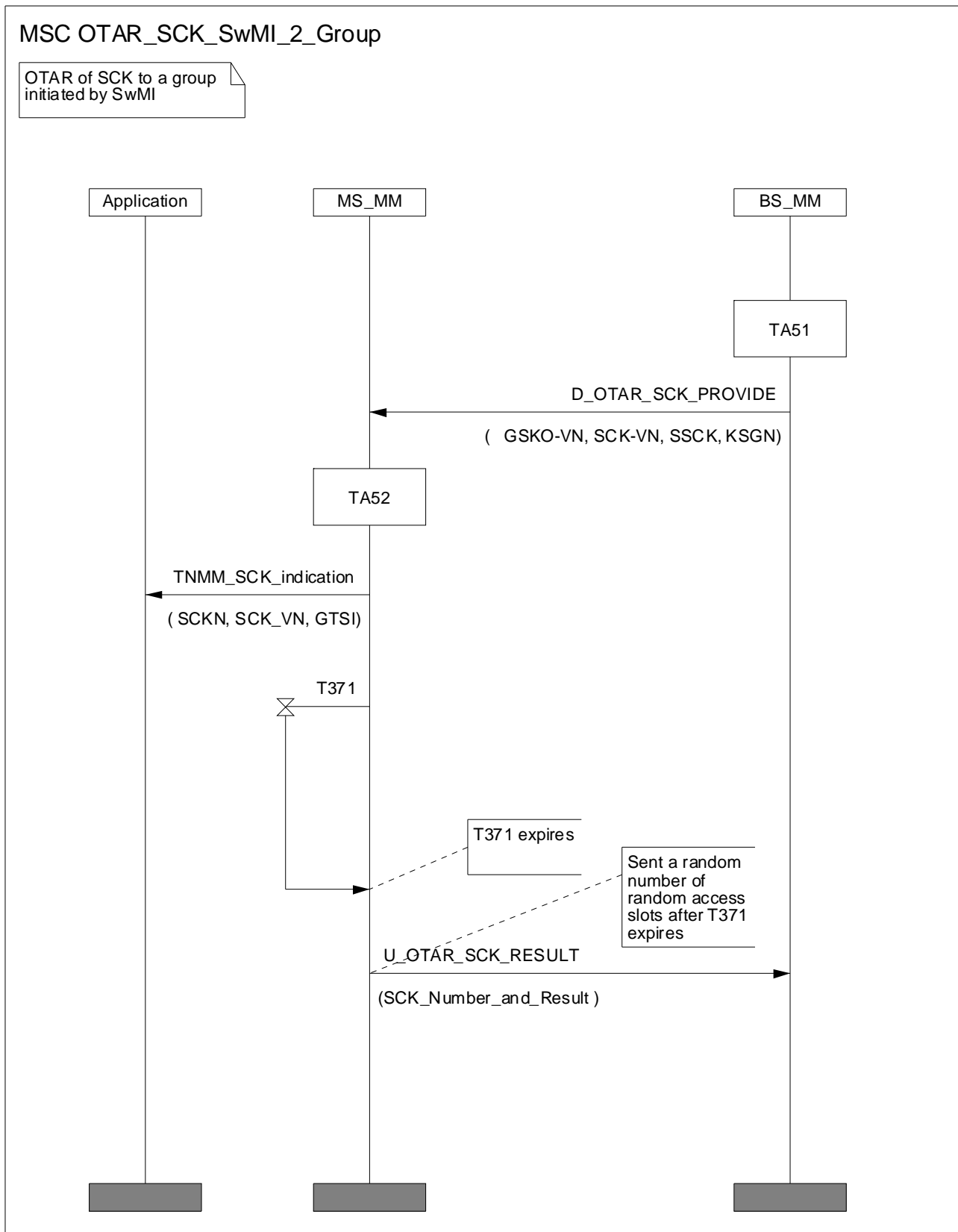

NOTE: Although SCK is sealed by the group key the D-OTAR SCK PROVIDE may be distributed to either a group or an individual address and encrypted appropriately.

Figure 31: SCK delivery to a group initiated by SwMI

4.5.2.4 SwMI rejects provision of SCK

If the SwMI is unable to provide an SCK the provision request shall be explicitly rejected using the D-OTAR SCK reject PDU indicating the reason for rejection. The SwMI shall indicate to the MS how long the MS shall wait before retrying a request for SCK by setting the value of the "OTAR retry interval" element. The behaviour of the MS shall be as described in clause 4.5.12.

4.5.3 OTAR protocol functions - GCK

Up to seven GCKs may be distributed to the MS using the "D-OTAR GCK Provide" PDU. The provision may be started automatically by the SwMI or in response to a request from the MS using the "U-OTAR GCK Demand" PDU. The most common cases are described by the MSCs and protocol description in the present clause.

The MS shall send U-OTAR GCK RESULT according to the rules below:

- For MS requests, and where the SwMI provides keys individually addressed to the MS, a result shall be sent (figure 32). When the SwMI responds individually addressed to the MS, the SwMI shall set Acknowledgement Flag to "Acknowledgement required" and Explicit Response to "Response to be sent whether state changed or not". However, the SwMI may provide keys addressed to a CMG GTSI, in response to an MS's individual request, in which case the MS shall interrogate the value of the Acknowledgement Flag to determine if an acknowledgement is required. If an acknowledgement is required the MS shall also interrogate the Explicit Response element in D-OTAR GCK PROVIDE. If set to "Response to be sent whether state changed or not" the MS shall respond whether the key provide changes the MS state or not; if set to "Response to be sent only if state of MS is changed", the MS shall only respond if the SwMI provides a key or key version that the MS did not previously have.
- For SwMI provision to a single MS a response shall always be sent (figure 33). The SwMI shall set Acknowledgement Flag to "Acknowledgement required" and Explicit Response to "Response to be sent whether state changed or not" when sending D-OTAR GCK Provide to a single MS.
- For SwMI provision to a CMG GTSI the MS shall interrogate the value of the Acknowledgement Flag to determine if an acknowledgement is required. If an acknowledgement is required the MS shall also interrogate the Explicit Response element in D-OTAR GCK PROVIDE. If set to "Response to be sent whether state changed or not" the MS shall respond whether the key provide changes the MS state or not; if set to "Response to be sent only if state of MS is changed", the MS shall only respond if the SwMI provides a key or key version that the MS did not previously have.

4.5.3.1 MS requests provision of GCK

The scenario in figure 32 shows the case where the MS requests provision of a GCK for a group. The MS may initiate this procedure at any time.

The MS may request GCKs associated with one or more GSSIs in which case it shall send a U-OTAR GCK Demand PDU to the SwMI indicating that it is requesting GCKs referenced by one or more GSSIs and shall include the GSSIs or GTSIs of the requested group(s). Alternatively, the MS may request a new version of one or more GCKs that it already possesses, or that it expects due to a Key Association. In this case, it shall send a U-OTAR GCK Demand PDU to the SwMI indicating that it is requesting one or more GCKs referenced by GCKNs, and shall include the GCKNs of the requested key(s). The MS may request GCKs referenced by GSSIs and GCKs referenced by GCKNs in the same PDU; however the total number of requests shall not exceed seven in a single U-OTAR GCK Demand PDU.

All GCKs requested in a single PDU shall belong to the same network, either the serving network in which case the "address extension" element shall not be provided, or any other network in which case the "address extension" element shall be provided and shall identify the network in which the GCKs are to be used.

The normal message sequence in this case shall be according to figure 32.

NOTE: Figure 32 shows individual encryption of GCK using KSO, however use of GSKO as shown in figure 34 is also possible for an individually or group addressed OTAR transmission.

For individual provision of GCKs to an MS using KSO as the sealing key, the "max response timer value" element in the provision PDU shall be set to indicate "Immediate response".

The SwMI shall respond with the requested keys using the D-OTAR GCK Provide PDU, together with the GCKN and GCK-VN information. The MS shall respond and inform the SwMI of the success or failure of the OTAR using the U-OTAR GCK Result PDU in accordance with the rules in clause 4.5.3. In case of failure, it shall indicate the reason, which may include failure to decrypt key, or SwMI provided the wrong key.

If the KSG identified in the U-OTAR GCK DEMAND is invalid the SwMI shall respond with error indication "KSG number not supported".

If the KSG identified in the D-OTAR GCK PROVIDE is invalid the MS shall respond with error indication "KSG number not supported".

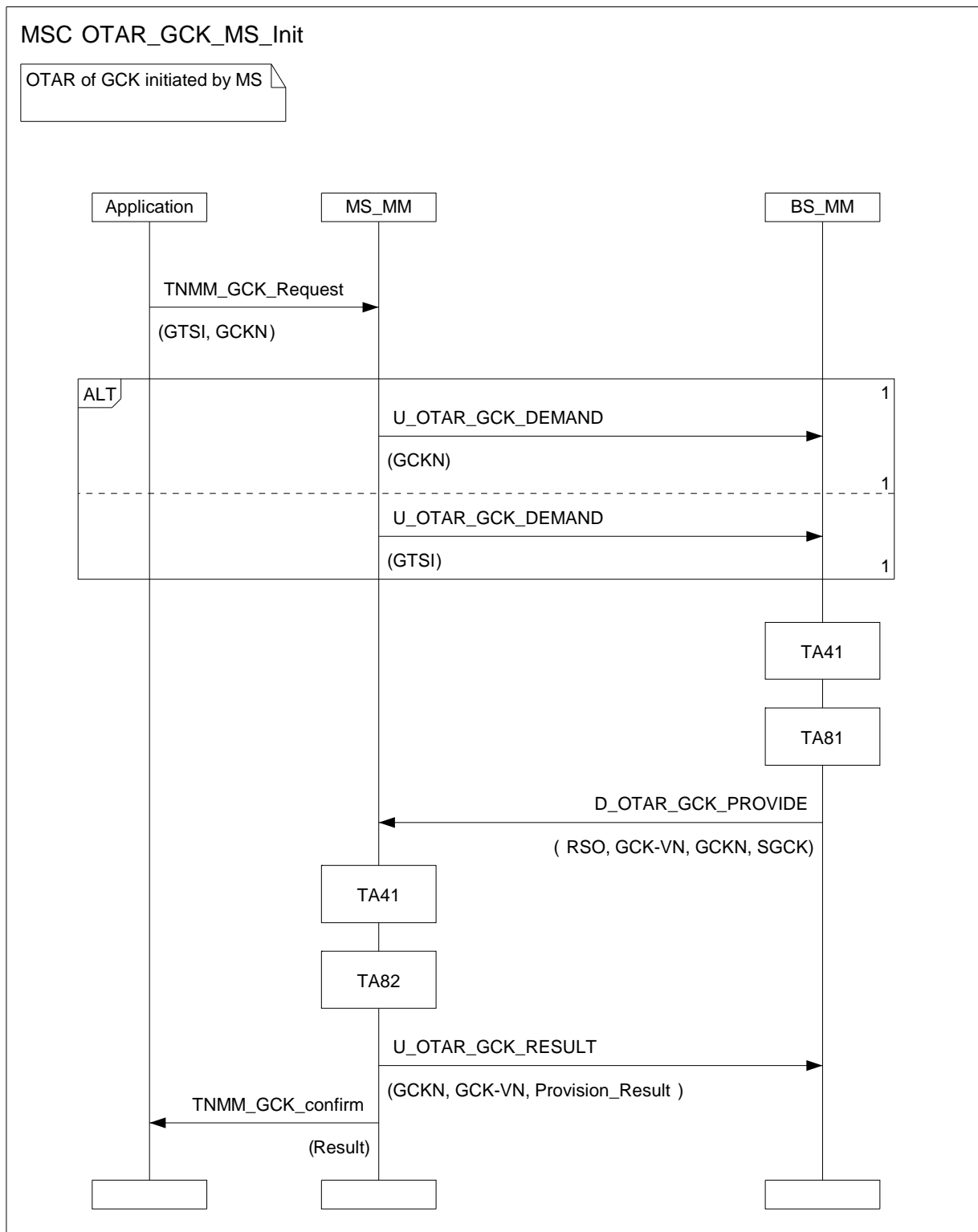

Figure 32: GCK delivery initiated by MS to an individual

4.5.3.2 SwMI provides GCK to an individual MS

The scenario in figure 33 shows the case where the SwMI provides a GCK to an MS without the MS first requesting GCK provision. The SwMI may initiate this procedure at any time. The SwMI shall provide the GCK to the MS using the D-OTAR GCK Provide PDU. The SwMI may provide one or more GCKs, each associated with a specific GSSI, in which case the Group Association element in the PDU shall indicate "GSSI" and the SwMI shall provide the GSSI. Alternatively, the GCK(s) may be either newer versions of a GCK that the MS already possesses, or new GCK(s) which will subsequently be associated with one or more GSSIs. In this alternative case the Group Association element in the PDU shall indicate "GCKN" and the SwMI shall provide the GCKN relevant to the GCK.

The normal message sequence in this case shall be according to figure 33.

NOTE: Figure 33 shows individual encryption of GCK using KSO, however use of GSKO as shown in figure 34 is also possible for an individually or group addressed OTAR transmission.

For individual provision of GCKs to an MS using KSO as the sealing key, the "max response timer value" element in the provision PDU shall be set to indicate "Immediate response". The MS shall respond and inform the SwMI of the success or failure of the OTAR using the U-OTAR GCK Result PDU. The options are as detailed in clause 4.5.3.1.

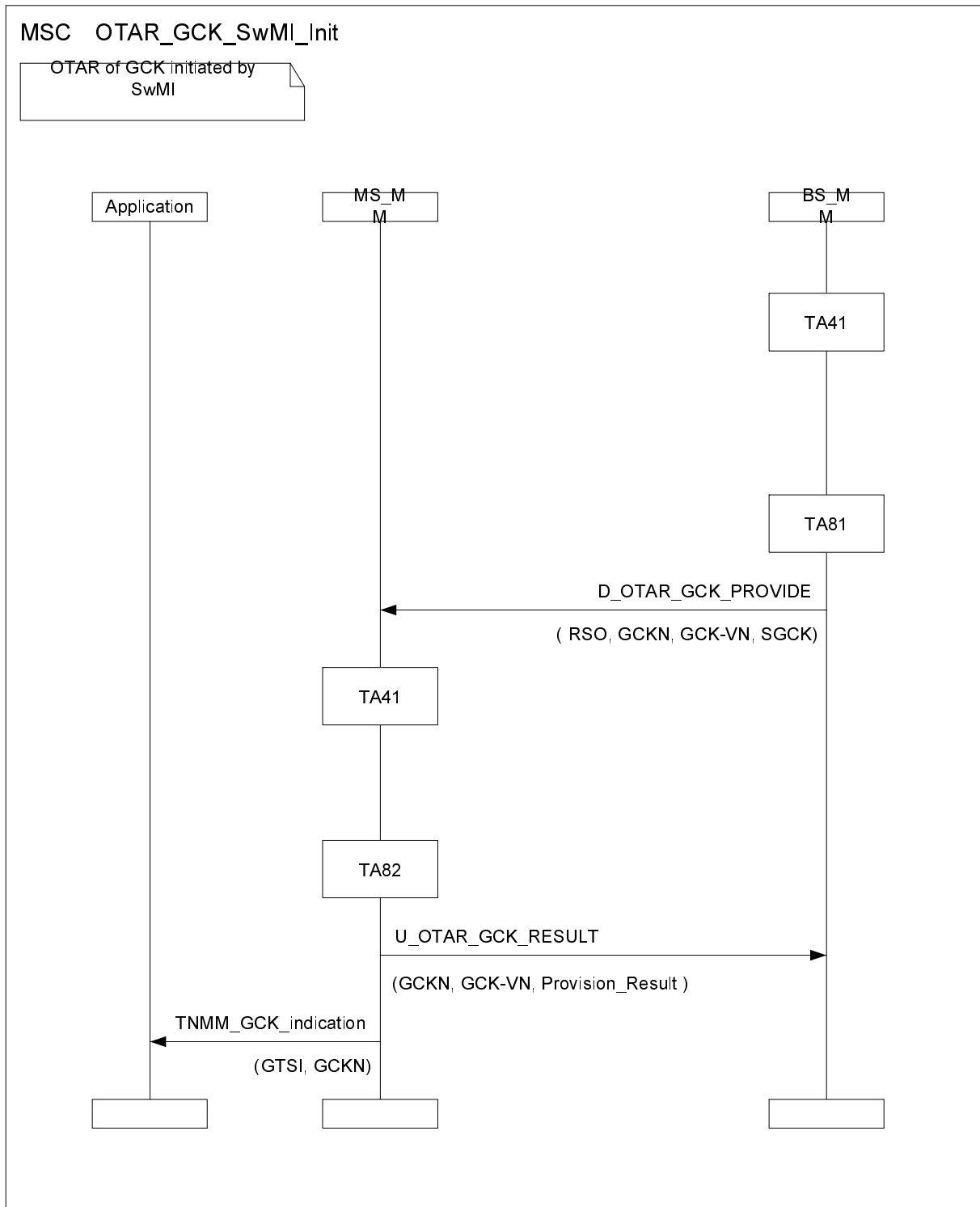

Figure 33: GCK delivery initiated by SwMI to an individual

4.5.3.3 SwMI provides GCK to a group of MSs

In the case of group sealed delivery of GCK, BS_MM and MS_MM shall not run TA41, but shall use EGSKO as input to TA81 and TA82. The U-OTAR GCK RESULT shall be sent from MS to SwMI following the expiry of random timer T371 provided that the Acknowledgement Flag is set to "Acknowledgement required" and either the GCK material provided is not currently stored in the MS, or the "explicit response" element of the D-OTAR GCK PROVIDE PDU is set to "Response to be sent whether state changed or not". T371 is started on reception of the D-OTAR GCK PROVIDE.

T371 is a timer with a value randomized to fall within the range 1 s and a maximum value that is signalled by the SwMI in the "max response timer value" element of the PDU. This maximum value may be up to 65 535 s (18,2 hours). The MS shall select a value in this range when setting T371. When T371 expires the MS shall wait a further random number of random access signalling slots before sending the U-OTAR GCK RESULT PDU. The procedure for randomly selecting the signalling slot shall follow the procedure for "Choosing from a new access frame" as defined in EN 300 392-2 [2], clause 23.5.1.4.6. If the MS needs to leave the SwMI by sending ITSI-Detach signalling the MS shall consider T371 to have terminated and shall send the U-OTAR GCK RESULT PDU before detaching from the SwMI.

The normal message sequence in this case shall be according to figure 34.

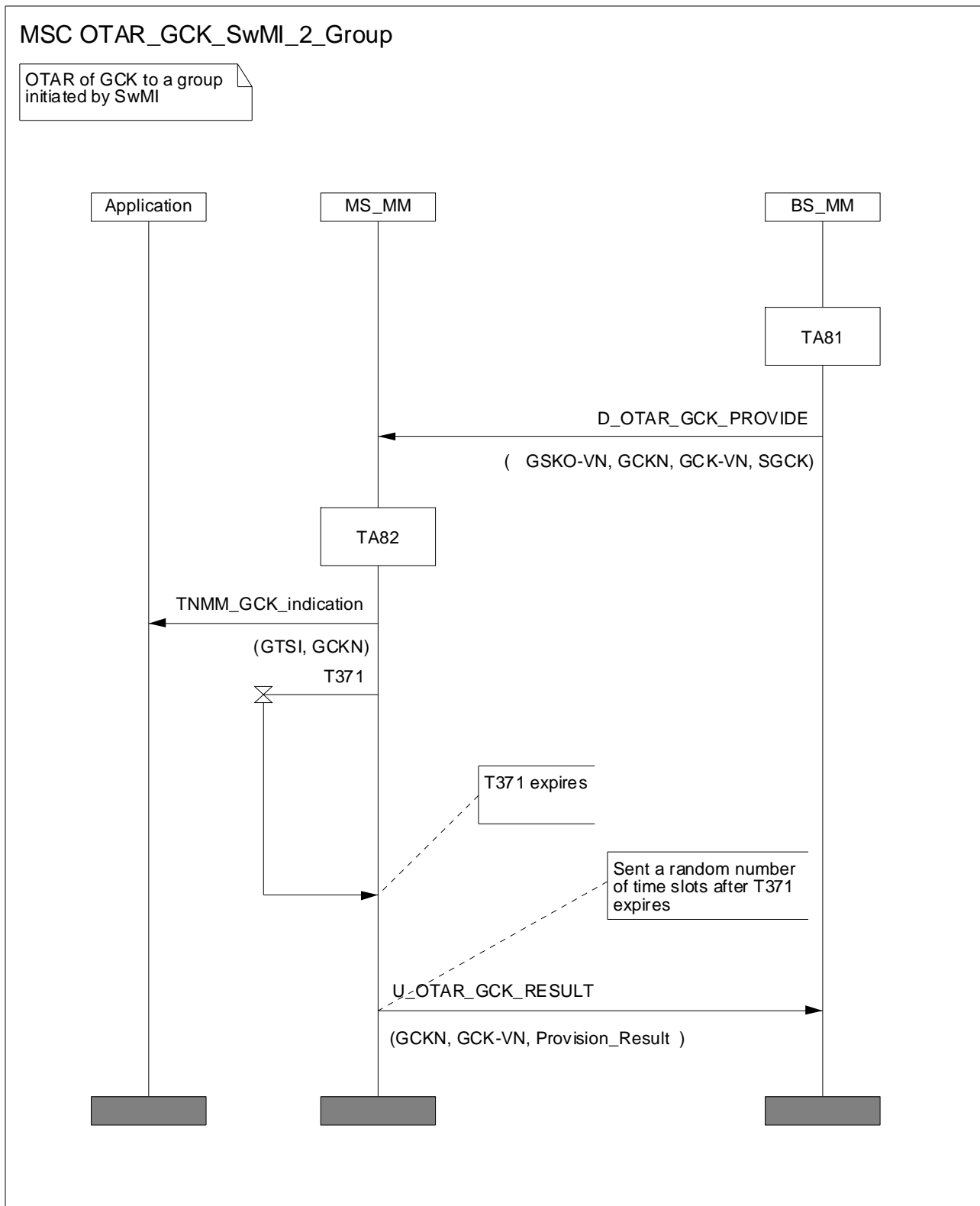

NOTE: Although GCK is sealed by the group key the D-OTAR GCK PROVIDE may be distributed to either a group or an individual address and encrypted appropriately.

Figure 34: GCK delivery to a group initiated by SwMI

4.5.3.4 SwMI rejects provision of GCK

If the SwMI is unable to provide a GCK the provision request shall be explicitly rejected using the D-OTAR GCK Reject PDU indicating the reason for rejection. The SwMI shall indicate to the MS how long the MS shall wait before retrying a request for GCK by setting the value of the "OTAR retry interval" element. The behaviour of the MS shall be as described in clause 4.5.12.

4.5.4 Cipher key association to group address

When provisioning a GSSI into an MS's group database using SS-DGNA, the SwMI may provide a *GCK Association* and/or *SCK Association* by including the *Security Related Information* element in D-FACILITY (ASSIGN) PDU, see table 6.1.

Table 6.1: Security Related Information Element

Information element	Length	Type	C/O/M	Value	Remark
GCK Association	1	1	M	0 ₂ 1 ₂	GCK association information not provided GCK association information provided
GCK Select Number	17	1	C		Provided if <i>GCK Association</i> indicates "GCK Association Information Provided"; IE defined in the present document
SCK Association	1	1	M	0 ₂ 1 ₂	SCK association information not provided SCK association information provided
SCK Subset Grouping Type	4	1	C		Provided if <i>SCK Association</i> indicates "SCK Association Information Provided"; IE defined in the present document
SCK Subset Number	5	1	C		Provided if <i>SCK Association</i> indicates "SCK Association Information Provided"; IE defined in the present document

When performing group attachment, the SwMI may provide a *GCK Association* and/or *SCK Association* by including a new *Group Identity Security Related Information* element (see table 6.2) in D-ATTACH/DETACH GROUP IDENTITY, D-ATTACH/DETACH GROUP IDENTITY ACK and D-LOCATION UPDATE ACCEPT.

Table 6.2: Group Identity Security Related Information Element

Information element	Length	Type	C/O/M	Value	Remark
Number of groups	5	1	M		Indicates the number of GSSI corresponding to the given key association that follows
GSSI	24	1	CM		Shall be present as many times as indicated in the "Number of groups" value
GCK Association	1	1	M	0 ₂ 1 ₂	GCK association information not provided GCK association information provided
GCK Select Number	17	1	C		Provided if GCK Association indicates "GCK Association Information Provided"; IE defined in the present document
SCK Association	1	1	M	0 ₂ 1 ₂	SCK association information not provided SCK association information provided
SCK Subset Grouping Type	4	1	C		Provided if SCK Association indicates "SCK Association Information Provided"; IE defined in the present document
SCK Subset Number	5	1	C		Provided if SCK Association indicates "SCK Association Information Provided"

4.5.4.1 SCK association for DMO

The OTAR KEY ASSOCIATE protocol exchange allows the SwMI to make links between keys and group addresses.

The SwMI may request that the MS associates a particular SCK (identified by SCKN) with up to 30 groups (identified by the "Number of groups" element of the PDU) for which the GSSI of each is listed, or for a range of groups identified by the first and last GSSIs in the range. In this case the key-type element of the D-OTAR KEY ASSOCIATE DEMAND shall be set to SCK.

The SwMI may request that the MS associates more than one SCK to one or more groups, where the SCKs are members of the same KAG in different SCK subsets. In this case, it will also identify the structure of the subsets and the member SCK to be associated. This is described in clause 4.5.4.2.

A later association shall take precedence over an earlier association. This allows the SwMI to make associations to ranges and sub-ranges of groups. The SwMI may associate one key with a wide range of groups, and then make an association of a second key with a narrower range within the first range. In this case, the first association still applies over the wide range with the exception of the narrow range, where the second later association shall apply.

The SwMI may also demand that groups be associated to SCKs by groups of MSs. In this case, the D-OTAR KEY ASSOCIATE DEMAND PDU is addressed to the group of MSs. If the Acknowledgement Flag element is set to indicate acknowledgement required the MS shall respond on expiry of random timer T371 provided that the Acknowledgement Flag is set to "Acknowledgement required" and either the key association is new to the MS, or provided that the "explicit response" element of the D-OTAR KEY ASSOCIATE DEMAND PDU is set to "Response to be sent whether state changed or not" (i.e. Response to be sent whether state changed or not). If so the MS shall start random timer T371 on reception of D-OTAR KEY ASSOCIATE DEMAND and send the U-OTAR KEY ASSOCIATE STATUS on expiry of T371. If the "explicit response" element is set to "0" (i.e. Response to be sent only if the state has changed), and the D-OTAR KEY ASSOCIATE DEMAND PDU does not change the MS's state (it already has the key association being signalled) it shall not send acknowledgement. If the MS needs to detach from the SwMI before sending the acknowledgement to the SwMI, it shall consider T371 to have expired and shall send the acknowledgement before detaching. T371 is described in clause 4.5.2.3. If the MS is unable to send the result PDU before detaching, it should store the PDU and send it next time it attaches to the SwMI, even if is switched off and on again in the meantime.

The value of T371 shall be provided to the MS by the SwMI in the "max response timer value" element. If the PDU is individually addressed to a single MS, this element shall be set to "0".

The normal message sequence in this case shall be according to figure 35.

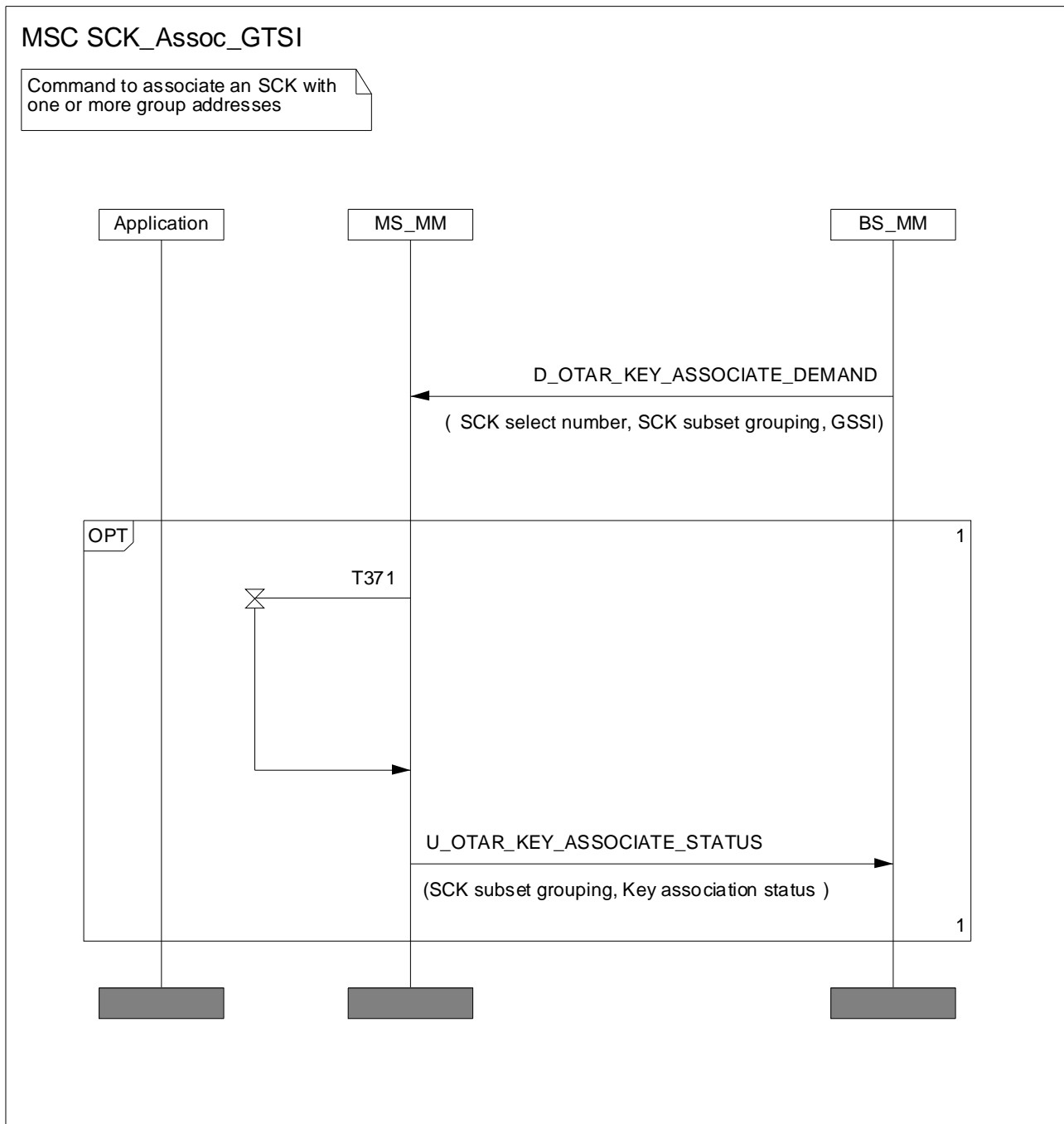

NOTE: The optional sequence is employed if the rules for sending U-OTAR KEY ASSOCIATE STATUS defined in clause 4.5.4.1 are enabled.

Figure 35: SCK association by SwMI

The SwMI may demand that the SCKs currently associated with the groups are disassociated forcing the groups to revert to clear operation. This is done by setting the "SCK select number" element to the value for "No SCKN selected".

The normal message sequence in this case shall be according to figure 36.

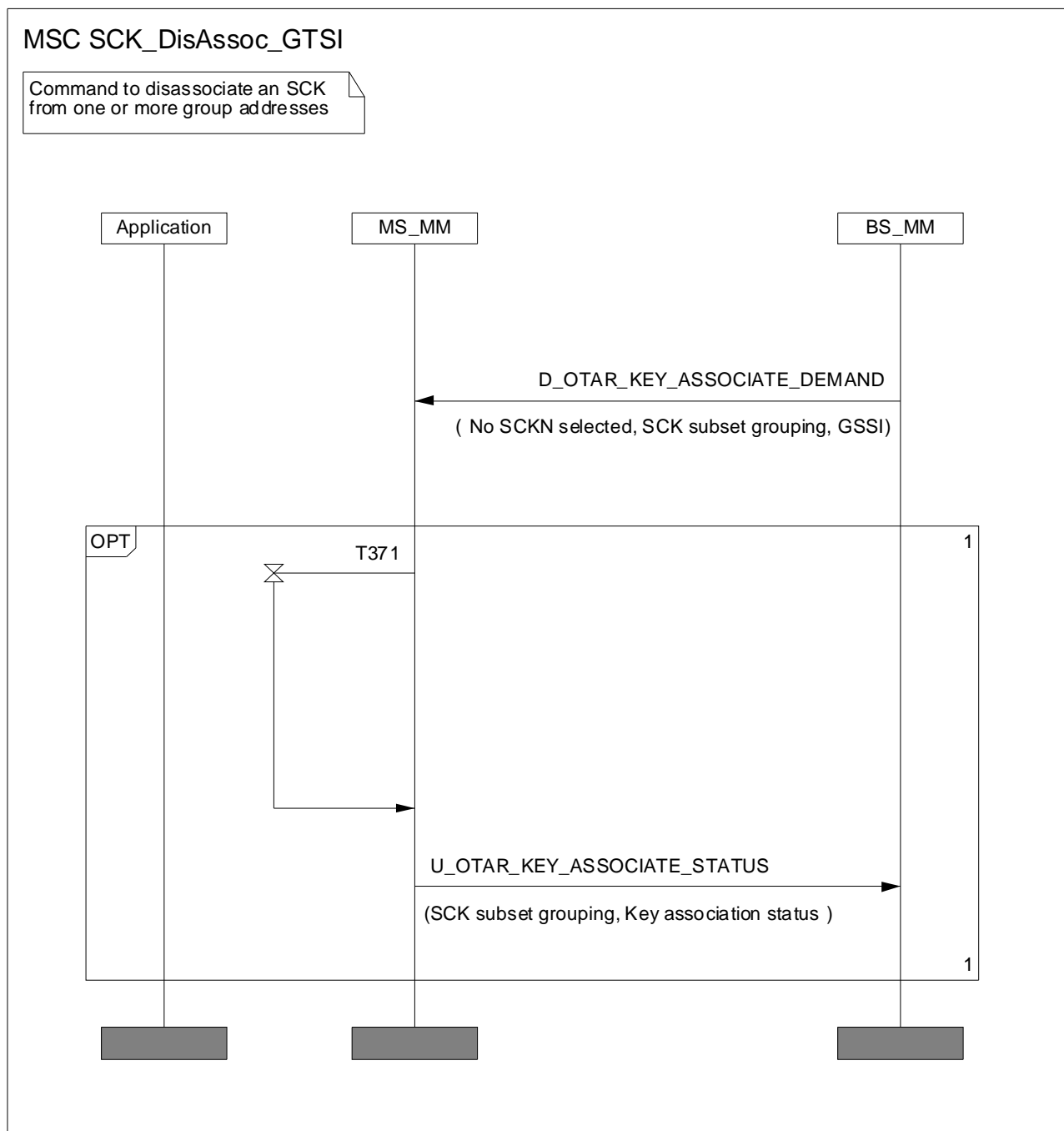

NOTE: The optional sequence is employed if the rules for sending U-OTAR KEY ASSOCIATE STATUS defined in clause 4.5.4.1 are enabled.

Figure 36: SCK disassociation by SwMI

If in either case, the SwMI requests the MS to associate keys with GSSIs that the MS does not possess, the MS can reject the association and indicate the status of this back to the SwMI. If the SwMI requests the MS to associate keys with a range of GSSIs, and the MS does not have GSSIs either at the end points of the range, or elsewhere in the range, it should still accept and maintain this association in case groups are subsequently loaded within this range.

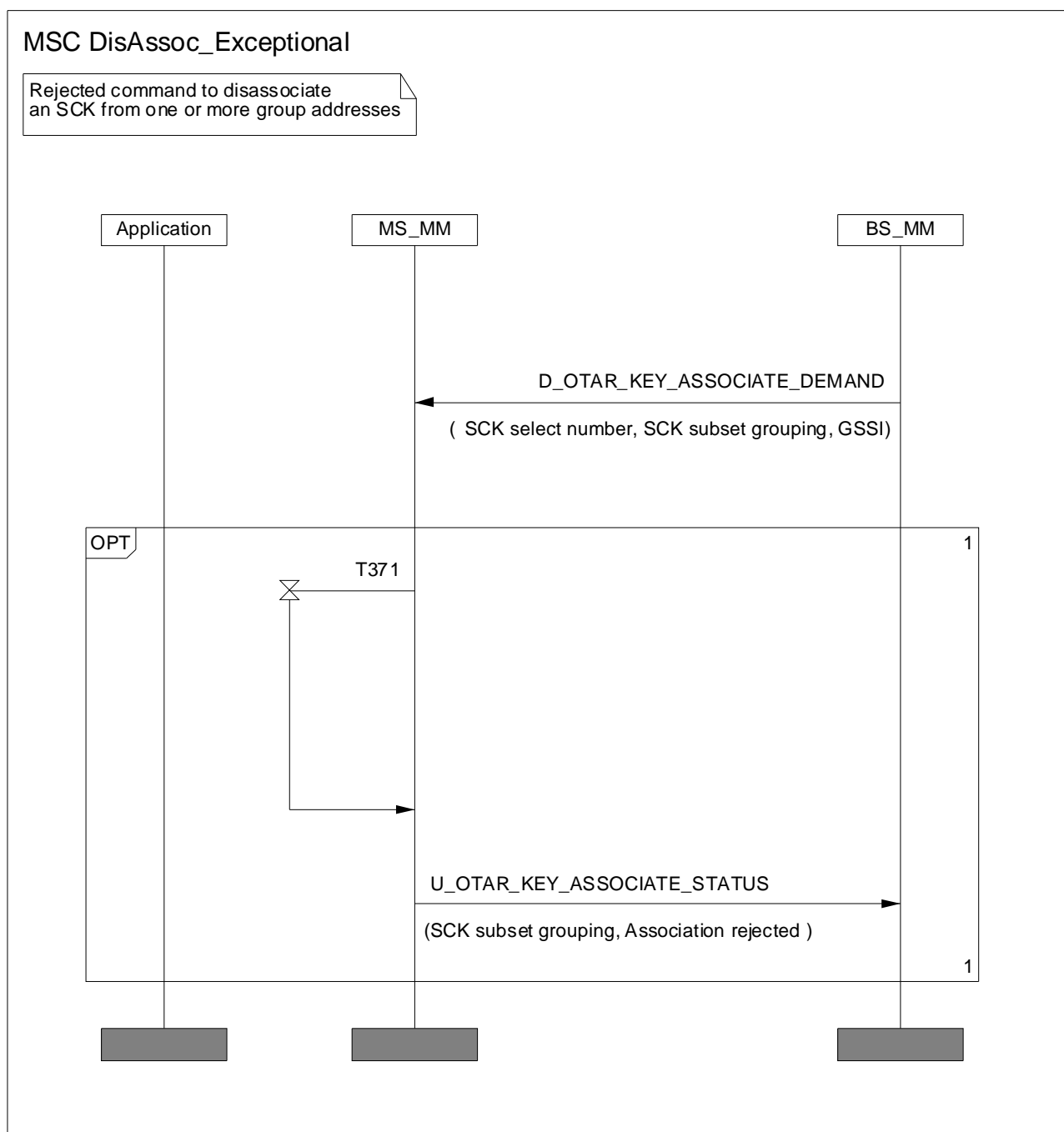

NOTE: The optional sequence is employed if the rules for sending U-OTAR KEY ASSOCIATE STATUS defined in clause 4.5.4.1 are enabled.

Figure 36a: Rejection of SCK disassociation

4.5.4.2 GCK association

The scenario in figure 37 shows the case where the SwMI requests the MS to associate a GCK (which the MS already has) with between 1 and 30 groups or a range of groups where the ends of the range are identified by a lower and higher value of GSSI.

The SwMI may also demand that groups may be associated to GCKs by groups of MSs. In this case, the D-OTAR KEY ASSOCIATE DEMAND PDU is addressed to the group of MSs. If the Acknowledgement Flag element is set to indicate acknowledgement required, the MS shall start random timer T371 on reception of D-OTAR KEY ASSOCIATE DEMAND and send the U-OTAR KEY ASSOCIATE STATUS on expiry of T371. T371 is described in clause 4.5.2.3.

The value of T371 shall be provided to the MS by the SwMI in the "max response timer value" element. If the PDU is individually addressed to a single MS, this element shall be set to "0".

The normal message sequence in this case shall be according to figure 37.

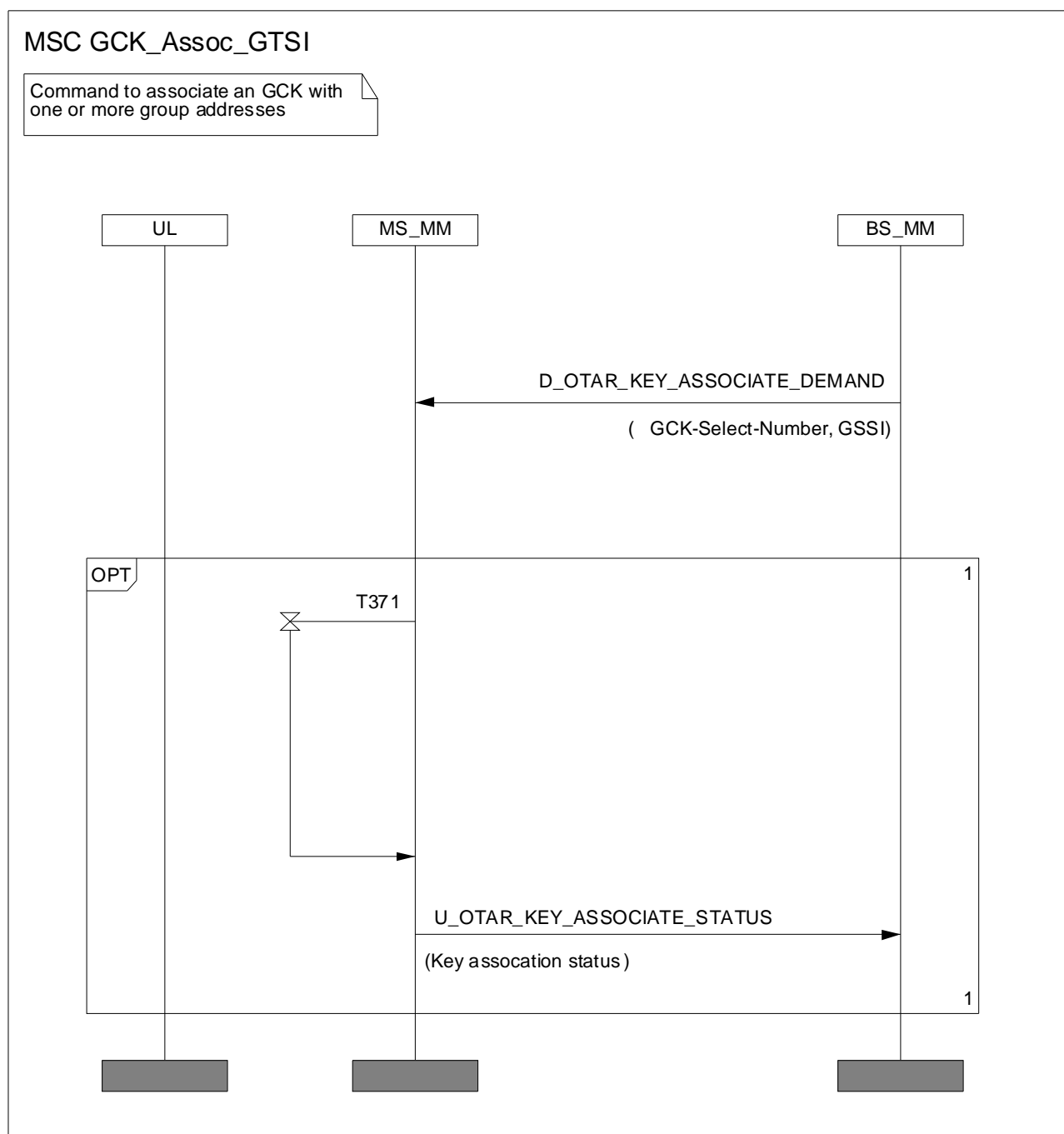

NOTE: The optional sequence is employed if the rules for sending U-OTAR KEY ASSOCIATE STATUS defined in clause 4.5.4.2 are enabled.

Figure 37: GCK association by SwMI

The SwMI may demand that the GCKs currently associated with the groups are disassociated forcing the groups to revert to using CCK (for security class 3 systems). This is done by setting the "GCK select number" element to the value for "No GCKN selected".

If in either case, the SwMI requests the MS to associate keys with GSSIs that the MS does not possess, the MS can reject the association and indicate the status of this back to the SwMI. If the SwMI requests the MS to associate keys with a range of GSSIs, and the MS does not have GSSIs either at the end points of the range, or elsewhere in the range, it should still accept and maintain this association in case groups are subsequently loaded within this range.

When using DGNA SS-DGNA defined in EN 300 392-12-22 [7] the "security related information" field includes GCK select number only to associate a GCK to the address defined in the core of the SS-DGNA message.

4.5.5 Notification of key change over the air

The MM security function of the BS/SwMI shall use the exchange shown in figure 38 to inform registered MSs of a future key change. In each case the SwMI should have previously distributed the new cipher key using the key management mechanisms described in clauses 4.5.1 to 4.5.3.

The D-CK CHANGE DEMAND/U-CK CHANGE RESULT shall be used to explicitly inform the MS of the time when a key shall be considered valid. The time may be described as either a value representing IV (composed of slot number, frame number, multiframe number and hyper frame number), or a time based upon TETRA network time as described in EN 300 392-2 [2]. The key-id shall be one of CCK-id, SCKN, and GCKN. The scope of the D-CK CHANGE DEMAND/U-CK CHANGE RESULT protocol exchange is the current cell.

On receipt of D-CK CHANGE DEMAND by MS-MM the indicated key and associated parameters shall be notified to the MAC using the MLE-ENCRYPTION request primitive. When the key is applied the MAC shall inform MS-MM of the change using the MLE-ENCRYPTION confirm primitive. If requested the MS-MM shall acknowledge the D-CK CHANGE DEMAND using the U-CK CHANGE RESULT PDU.

If the MS does not possess the key it shall request the key from the SwMI using the appropriate OTAR request PDU. The MS shall randomize the sending of the OTAR request over the time interval between reception of D-CK CHANGE DEMAND and the actual time when the change will occur. If the OTAR request is not sent before leaving the cell or detaching from the SwMI the requirement to request the key shall be cancelled.

Acknowledgement of D-CK CHANGE DEMAND shall be made for ITSI based key delivery using the U-CK CHANGE RESULT PDU by setting the "acknowledgement flag" element on the downlink PDU to "1". If this is set to "1", the MS shall acknowledge whether the demand changes the MS's state or not.

The D-CK CHANGE DEMAND may also be transmitted addressed to a group of MSs or the broadcast address. In this case the acknowledgement is optional, either acknowledgement shall not be requested by setting the "acknowledgement flag" element to FALSE, or if acknowledgement is requested the MS shall start timer T371 with a randomly selected value on receipt of the D-CK CHANGE DEMAND. However, even if the "acknowledgement flag" = "1", the MS shall only acknowledge if the D-CK CHANGE DEMAND changes its state, i.e. it has not already received and stored the result of the same key change command. The procedure for randomly selecting the signalling slot shall follow the procedure for "Choosing from a new access frame" as defined in EN 300 392-2 [2], clause 23.5.1.4.6. On expiry of T371, the MS responds with a U-CK CHANGE RESULT PDU. The value of T371 shall be such that the acknowledgement is received by the SwMI before the time that the key becomes valid.

The value of T371 shall be randomized over the time interval between receipt of the PDU and the time identified in the PDU for the key change.

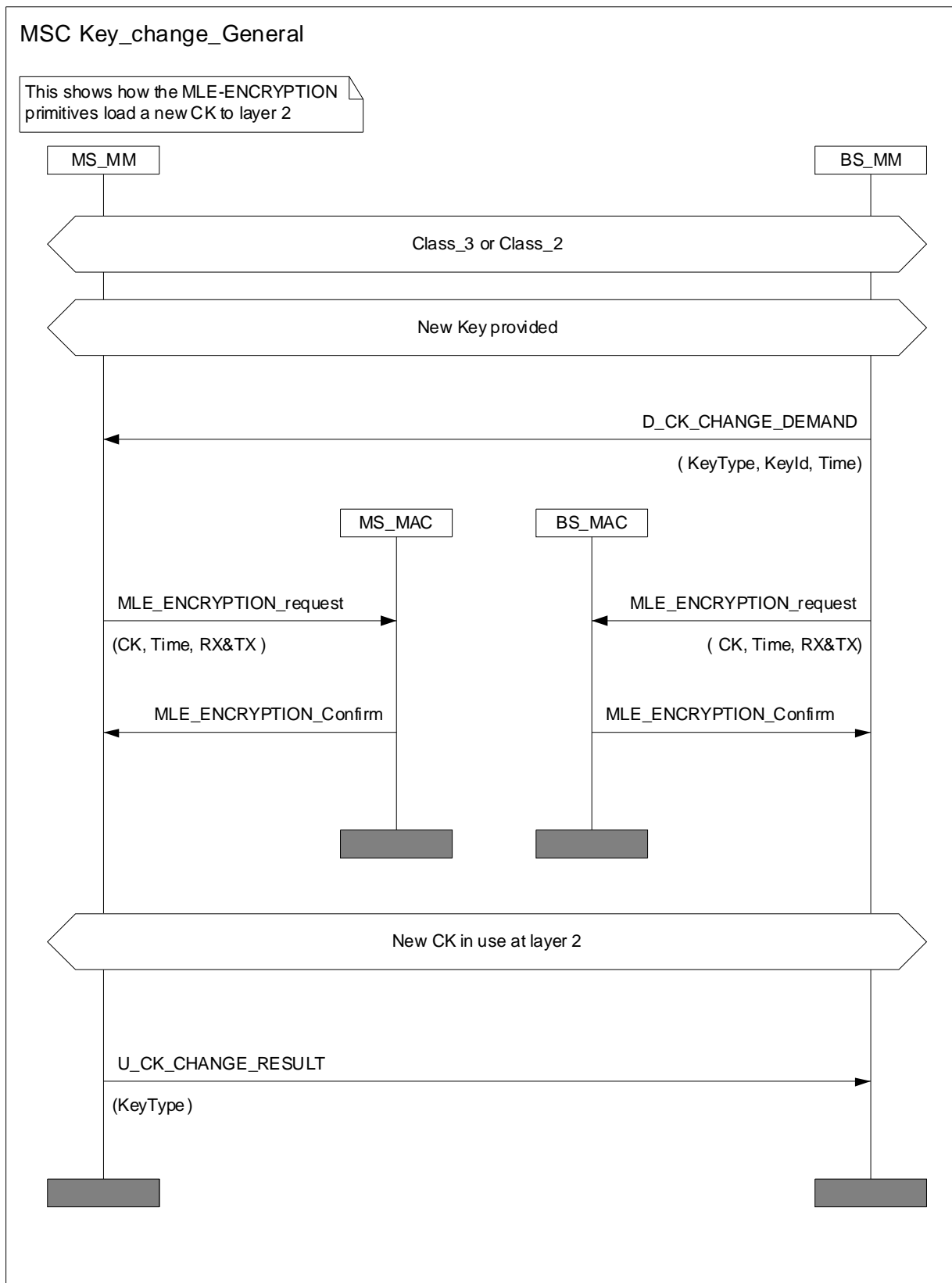

Figure 38: Key change protocol

4.5.5.1 Change of DCK

DCK shall be changed explicitly using the authentication protocols described in clause 4.4.2.

The DCK in use shall change at the following times:

- on successful authentication;
- if a DCK has been previously established and is in use it shall be retained throughout the authentication protocol and only discarded after confirmation of the success of the authentication.

The new DCK shall be considered valid after the last repeat of the PDU containing the result R1 or R2 (as authentication PDUs are transmitted using layer 2 acknowledgement the receipt of the acknowledgement of the RESULT PDU shall be the trigger to invoke the new DCK). The MS and SwMI shall be synchronized at this time.

4.5.5.2 Change of CCK

The SwMI may administer the change of CCK using the D-CK-CHANGE-DEMAND PDU. Each cell in an LA shall update the CCK in use as indicated in the D-CK-CHANGE-DEMAND PDU.

NOTE: It is at the discretion of the SwMI how much warning of CCK change is given.

The SwMI MM shall notify all MSs in the cell of the new CCK-id in the SYSINFO broadcast and in the header of the MAC-RESOURCE PDU described in clause 6.5.1.

When the SwMI changes the CCK for downlink, it will still receive two slots where ESIs are encrypted with the old CCK on the uplink. For the duration of these two slots the SwMI shall use old CCK for decrypting ESI addresses in the uplink and new CCK for encrypting in the downlink.

For change of CCK the D-CK-CHANGE-DEMAND may be addressed to group and broadcast addresses.

4.5.5.3 Change of GCK

The SwMI may administer the change of GCK using the D-CK CHANGE DEMAND PDU. Where the procedure is used the D-CK CHANGE DEMAND PDU may be addressed to group and broadcast addresses.

The SwMI may choose to link the crypto-periods of all GCKs on the network, in this case all GCKs have the same GCK-VN and only one GCK-VN need be conveyed to the MS. If the SwMI supports the latter mechanism, a short GCK-VN (representing the 2 least significant bits of the GCK-VN) shall be conveyed in the *Security Information Element* of SYSINFO, with the full GCK-VN provided using D-CK CHANGE DEMAND with *Key Change Type* of "All GCKs".

4.5.5.4 Change of SCK for TMO

If over the air cipher key selection is provided the SwMI may administer the change of SCK using the D-CK CHANGE DEMAND PDU. This shall be performed across the entire network.

The SwMI MM shall notify all MSs in the cell of the new SCKN/SCK-VN in the SYSINFO broadcast, and SCK-VN in the header of the MAC-RESOURCE PDU described in clause 6.5.1.

When the SwMI changes the SCK for downlink, it will still receive two slots encrypted with the old SCK. For the duration of these two slots the SwMI shall use old SCK for decrypting ESI addresses and message contents in the uplink and new SCK for encrypting in the downlink.

For change of SCK the D-CK CHANGE DEMAND may be addressed to group and broadcast addresses.

4.5.5.5 Change of SCK for DMO

The "SCK use" element in the OTAR SCK PDU shall indicate whether the SCK is to be used for DMO or TMO operation. The SwMI may use the D-CK CHANGE DEMAND PDU to inform the MS which SCK(s) are in use for Direct Mode Operation (DMO). The use of SCK in DMO shall be indicated in the "SCK use" element. The change of SCK may be immediate or instead occur on a specific IV/network time. The SwMI may indicate whether one or several specific SCKs are to be used, or whether a complete subset of SCKs is to be used. In the latter case, the SwMI shall indicate the relevant subset. If a complete subset is to be changed at the same time, the SwMI shall ensure that the SCK-VNs of all SCKs in the subset are the same. The SCK-VN common to all SCKs to be made active shall be included in the D-CK CHANGE DEMAND PDU.

If an MS receives a D-CK CHANGE DEMAND PDU and does not have the SCK-VN for either an individual SCK, or for a subset of SCKs, then it may request OTAR of new SCKs.

4.5.5.6 Synchronization of Cipher Key Change

When the D-CK CHANGE DEMAND PDU is used to indicate a change of cipher key or security class of the LA, the "Time Type" element shall be used to indicate the exact moment of change and may take one of the following forms:

- **Absolute IV:** the SwMI shall activate the new cipher key on the indicated IV. In this case all 16 bits of the hyperframe number shall be used;
- **Network time:** the SwMI shall activate the new cipher key on the Network time. If the Network time falls between slot boundaries, the SwMI shall round up to the next slot number of the downlink; or
- **Immediate:** the SwMI shall activate the new cipher key on the first slot of the first frame of the next downlink multiframe.

When D-CK CHANGE DEMAND is used to indicate a change of cipher key and/or security class, the security parameters transmitted in MAC-SYSINFO shall also be synchronized with the change of cipher key or security class.

4.5.6 Security class change

The SwMI may send D-CK CHANGE DEMAND on control channels and on assigned channels to invoke transitions between any of the following security classes:

- Security Class 1;
- Security Class 2;
- Security Class 3 without GCK;
- Security Class 3 with GCK.

NOTE: Conceptually, "Security Class 3 with GCK" is treated as a separate security class.

In order to avoid unnecessary re-registration attempts by registered MS during security class changes (described above), the following behaviour is expected from the MS:

- If an MS had registered with **Ciphering On** in Security Class 2, or Security Class 3, or Security Class 3 with GCK, and the cell subsequently transitions to Security Class 1, then the MS shall temporarily override its registered ciphering mode with **Ciphering Off**, and shall remain registered providing it supports Security Class 1. Furthermore, if the cell subsequently transitions to Security Class 2, or Security Class 3, or Security Class 3 with GCK, then the MS shall resume its previous ciphering mode (i.e. prior to the override) of **Ciphering On**, and shall remain registered providing it supports the new security class and possesses the relevant key material for that security class. However, if the MS is unable to support the resumed ciphering mode of Ciphering On in the new security class, then the MS shall either re-register to request Ciphering Off or perform cell re-selection, whichever is most appropriate.

- If an MS had registered with **Ciphering On** in Security Class 2, or Security Class 3, or Security Class 3 with GCK, and the cell subsequently transitions to Security Class 2, or Security Class 3, or Security Class 3 with GCK, then the MS shall continue to use the existing ciphering mode of **Ciphering On**, and shall remain registered providing it supports the new security class and possesses the relevant key material for that security class. However, if the MS is unable to support the same ciphering mode of Ciphering On in the new security class, then the MS shall either re-register to request Ciphering Off or perform cell re-selection, whichever is most appropriate.
- If an MS had registered with **Ciphering Off** in Security Class 2, or Security Class 3, or Security Class 3 with GCK, and the cell subsequently transitions to Security Class 1, or Security Class 2, or Security Class 3, or Security Class 3 with GCK, then the MS shall continue to use the existing ciphering mode of **Ciphering Off**. However, if the MS needs to change its ciphering mode to Ciphering On following the security class change, then the MS shall either re-register to request Ciphering On or perform cell re-selection, whichever is most appropriate.
- If an MS had registered with **Ciphering Off** in Security Class 1 and the cell subsequently transitions to Security Class 2, or Security Class 3, or Security Class 3 with GCK, then the MS shall re-register to negotiate a ciphering mode that is acceptable to the SwMI which may result in the MS continuing to use Ciphering Off.
- If the MS supports the new security class but needs to obtain the relevant key material, then the MS shall re-register to obtain the keys through OTAR.
- If the MS does not support the new security class or does not support OTAR of the relevant key material then the MS shall invoke cell re-selection procedures.

4.5.6.1 Change of security class to security class 1

The SwMI may use the D-CK CHANGE DEMAND PDU to inform the MS that the security class of the cell will change to security class 1. In this instance, the SwMI shall identify no cipher key as being active. The change of security class may be immediate or occur on a specific IV/network time.

The SwMI shall set the "Change of security class" element of D-CK CHANGE DEMAND to "Transition to security class 1", and set the "Key change type" element to "No cipher key".

4.5.6.2 Change of security class to security class 2

The SwMI may use the D-CK CHANGE DEMAND PDU to inform the MS that the security class of the cell will change to security class 2. In this instance, the SwMI shall identify the active SCKN and SCK-VN. The change of security class may be immediate or occur on a specific IV/network time.

The SwMI shall set the "Change of security class" element of D-CK CHANGE DEMAND to "Transition to security class 2", and set the "Key change type" element to "SCK" and set the "SCK use element" to "TMO".

4.5.6.3 Change of security class to security class 3

The SwMI may use the D-CK CHANGE DEMAND PDU to inform the MS that the security class of the cell will change to security class 3. In this instance, the SwMI shall identify the active CCK-id. The change of security class may be immediate or occur on a specific IV/network time.

The SwMI shall set the "Change of security class" element of D-CK CHANGE DEMAND to "Transition to security class 3", and set the "Key change type" element to "CCK".

NOTE: If the "DCK retrieval during initial cell selection" is not supported by the SwMI, the MS may consider the previously established DCK to be valid only if the DCK has been generated after the last ITSI-Attach or migration location updating in this SwMI. If the SwMI does not support the "DCK retrieval during cell re-selection", the MS may consider the previously established DCK to be valid only if the DCK has been last used within this LA and after the last ITSI-Attach or migration location updating.

4.5.6.4 Change of security class to security class 3 with GCK

The SwMI may use the D-CK CHANGE DEMAND PDU to inform the MS that the security class of the cell will change to security class 3 with GCK. In this instance, the SwMI shall identify the active CCK-id and GCK-VN. The change of security class may be immediate or occur on a specific IV/network time.

The SwMI shall set the "Change of security class" element of D-CK CHANGE DEMAND to "Transition to security class 3", and set the "Key change type" element to "Class 3 CCK and GCK activation".

4.5.7 Notification of key in use

When the D-CK CHANGE DEMAND PDU is used to indicate an active cipher key, the "Change of Security Class" element shall indicate "No change of Security Class ", and "Time Type" element shall be set to indicate "Currently in use". This may be used by the SwMI to indicate the following information to the MS:

- the current GCK-VN for all GCKs;
- the current SCKN and SCK-VN of a fallback SCK for the SwMI;
- the current SCKN and SCK-VN of a DM-SCK(s) associated with DMO; or
- the current subset of SCKs for a subset of DM-SCKs associated with DMO.

4.5.8 Notification of GCK Activation/Deactivation

When the D-CK CHANGE DEMAND PDU is used to indicate activation or deactivation of GCKs in the cell, the "Key Change Type" shall be set to either "GCK Activation" or "GCK De-activation" respectively. This shall be synchronized with the change of the "GCK Supported" information element in SYSINFO.

4.5.9 Deletion of SCK, GCK and GSKO

Prior to key deletion using the mechanisms described in this clause there should be no associations to groups for those keys that are to be deleted.

The SwMI should be authenticated by the MS before keys or key associations are deleted, this may be explicit or implicit.

The deletion of the TM-SCK in a class 2 SwMI using the mechanisms described in this clause should be carefully considered.

NOTE: EN 300 812 [4] does not support a delete mechanism.

The SwMI may delete SCKs, GCKs or GSKOs currently contained within an MS by an explicit Key Delete command. The SwMI shall send a D-OTAR Key Delete Demand PDU to the MS. The PDU shall be sent to MSs individually, it shall not be sent to groups of MSs.

If a single or a list of SCKs is to be deleted, the SwMI shall set the "Key delete type" element to "Individual SCK(s)", and shall list the SCKNs of the keys to be deleted. The MS shall delete the required key(s) and shall respond with a U-OTAR Key Delete Result PDU listing the SCKs that have been deleted. If the MS cannot delete one of the keys, for example if it does not possess the requested key, it shall not include that SCKN in the responding PDU. Therefore, if deletion of a single SCK was requested, but the MS does not possess the SCK, the "number of SCKs deleted" element shall be set to zero and no "SCKN" element shall be included in the PDU.

If the SCK set is divided into subsets for DMO use, and a complete KAG is to be deleted (for example to remove all keys associated with a particular GSSI), the SwMI shall set the "Key delete type" to "SCK subset", and shall indicate the number of SCKs to be deleted per subset in the "Number of SCKs deleted" element (which is also the number of SCKN elements to be provided in the PDU). The SCKN elements shall only correspond to the SCKNs in the first subset of SCKs, i.e. the subset with SCKN = 1 as its lowest value. Therefore if multiple SCKNs are included in the PDU, the MS shall delete a number of SCKs equal to the "Number of SCKs deleted" element multiplied by the number of subsets in use.

EXAMPLE: If the SwMI and MS use 3 subsets of 10 keys each, corresponding to "SCK subset grouping type" element value of 010, and the SwMI instructs the MS to delete SCKN = 3 and SCKN = 7, (i.e. "Number of SCKs deleted" is 2), the MS shall also delete SCKNs = 13, 17, 23 and 27.

The MS shall respond with the U-OTAR Key Delete Result PDU indicating the SCKs deleted. It shall indicate to the SwMI the SCK subset grouping in use, and indicate which keys have been deleted by reference to the SCKNs in the first set only. If the MS does not possess any of the sets of members required, it shall omit those SCKNs from the U-OTAR Key Result PDU.

If the SCK set is divided into subsets for DMO use, and an entire subset is to be deleted, the SwMI shall set the "Key delete type" element value to "SCK subset" to indicate deletion of an entire subset, and shall include the subset grouping and subset number in the corresponding elements. Only one subset shall be deleted by a single PDU, and the SwMI shall send further PDUs if the deletion of more than one subset is required. The MS shall respond with the same element values in the U-OTAR Key Delete Result PDU. If the MS is not using the subset grouping proposed by the SwMI, it shall not delete the requested SCKs, and it shall instead indicate a mismatch by setting the "SCK subset grouping" element in the U-OTAR Key Delete Result PDU to "SCK grouping not valid" and the "SCK subset number" element to "0000".

If the SwMI requires the MS to delete all SCKs, it shall indicate this by setting the "Key delete type" element to "All SCKs". The MS shall delete all SCKs and respond with the same value of "Key delete type" element in the U-OTAR Key Delete Result PDU.

If the SwMI requires the MS to delete one or more GCKs, it shall indicate this by setting the "Key delete type" element to "Individual GCKs", it shall indicate the number of GCKs to be deleted in the "Number of GCKs deleted" element and list the GCKNs. The MS shall delete all versions (i.e. all corresponding GCK-VNs) of the required GCKN if it has more than one version stored. The MS shall indicate the GCKNs deleted back to the SwMI with the U-OTAR Key Delete Result PDU. If it cannot delete any of the GCKs because it is not provisioned with them, it shall omit these from the list. Therefore, if deletion of a single GCK was requested, but the MS does not possess the GCK, the "number of GCKs deleted" element shall be set to "0000" and no "GCKN" element shall be included in the PDU.

If the SwMI requires the MS to delete all GCKs, it shall indicate this by setting the "Key delete type" element to "All GCKs". The MS shall delete all GCKs and respond with the same value of "Key delete type" element in the U-OTAR Key Delete Result PDU.

If the SwMI requires the GSKO to be deleted, it shall indicate this by setting the "Key delete type" element to "GSKO". The MS shall delete the GSKO and respond with the same value of "Key delete type" element in the U-OTAR Key Delete Result PDU. If the MS contains more than one version of GSKO, it shall delete all versions (i.e. all values of GSKO-VN). It shall additionally send the GSKO-VN in the U-OTAR Key Delete Result PDU: if more than one version of GSKO-VN was held by the MS, it shall send the highest value of GSKO-VN that it possessed.

Figure 38a shows the message sequence chart for the key deletion protocol.

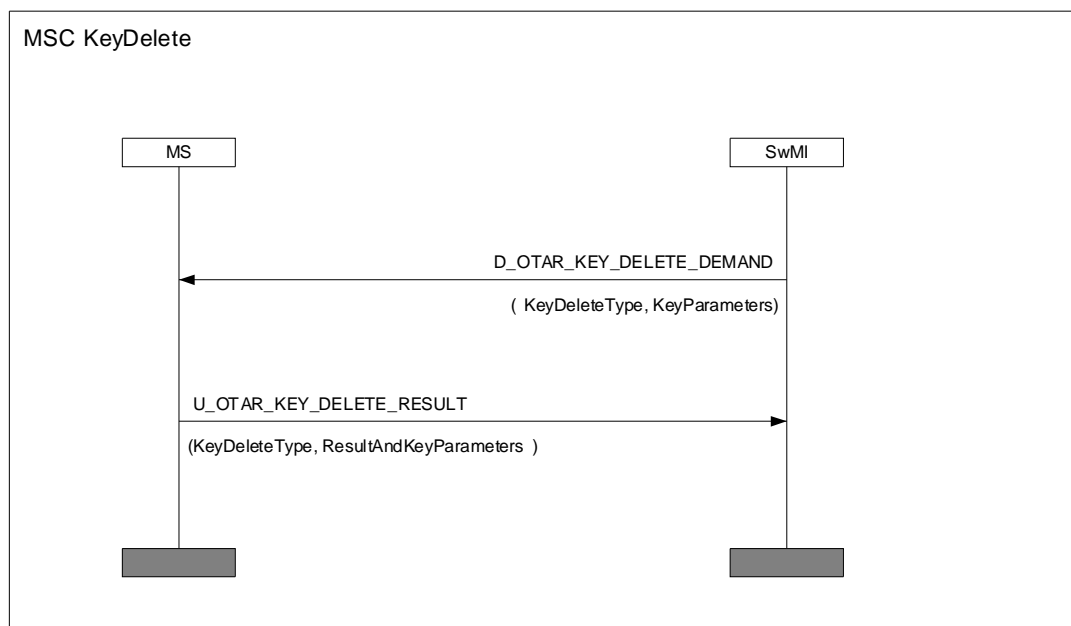

Figure 38a: Message sequence chart showing key deletion

4.5.10 Air Interface Key Status Enquiry

The SwMI shall be able to discover the current numbers and versions of air interface keys held by an MS by means of a status enquiry. The purpose of this mechanism is to allow a SwMI to maintain a record of the MS keying state, without needing to explicitly update the MS with new key material to force a response, which can make intensive use of air interface bandwidth.

The SwMI shall send a D-OTAR Key Status Demand to the MS. It may be individually or group addressed. The SwMI may request the state of:

- a single SCK, specified by SCKN;
- a subset of SCKs used for DMO, identified by the SCK subset grouping pattern used and SCK subset number;
- all SCKs in the MS;
- a single GCK, identified by GCKN;
- all GCKs in the MS; or
- the GSKO or multiple versions of GSKOs in the MS.

The MS shall respond with a U-OTAR Key Status Response containing key number (if applicable) and version number of the requested keys, if it has them.

If the SwMI requests the status of an individual SCK, identified by SCKN, and the MS possesses the SCK requested, the MS shall respond setting the "Number of SCK status" element to a value of "1" and shall include a single "SCK data" element containing the SCKN and SCK-VN of that SCK. If the MS does not possess the SCK requested, it shall set the "Number of SCK status" element to "0" and shall not provide any "SCK data" element.

If the SwMI requests the status of a subset of SCKs as used for DMO, it shall include the subset grouping pattern in use and the subset number requested. The MS shall respond with the SCK subset grouping and SCK subset number requested, and shall indicate how many SCKs it is providing data for in the "Number of SCK status" element, and shall provide this number of "SCK data" elements, each containing SCKN and SCK-VN for one key. If the MS does not use the SCK subset grouping pattern demanded by the SwMI (i.e. the MS uses a different pattern), it shall set the "SCK subset grouping" element to "SCK grouping not valid" and the "SCK subset number" element to "00000" indicating a grouping mismatch. It shall set the "Number of SCK status" element to "0" and shall not provide any SCK data elements. If the MS has the same pattern as indicated by the SwMI, but does not have any keys in the subset, it shall set the "SCK subset grouping" and "SCK subset number" elements to the values in use, shall set the "Number of SCK status" element to "0", and shall not provide any "SCK data" element.

If the SwMI requests the status of all SCKs in the MS, the MS shall respond indicating how many SCKs it is providing data for in the "Number of SCK status" element, and shall provide this number of "SCK data" elements, each containing SCKN and SCK-VN for one key. If the MS does not possess any SCKs, it shall set the "Number of SCK status" element to "0" and shall not provide any "SCK data" element.

If the SwMI requests the status of an individual GCK, identified by GCKN, and the MS possesses the GCK requested, the MS shall respond setting the "Number of GCK status" element to a value of "1" and shall include a single "GCK data" element containing the GCKN and GCK-VN of that GCK. If the MS does not possess the GCK requested, it shall set the "Number of GCK status" element to "0" and shall not provide any "GCK data" element.

If the SwMI requests the status of all GCKs in the MS, the MS shall respond indicating how many GCKs it is providing data for in the "Number of GCK status" element, and shall provide this number of "GCK data" elements, each containing GCKN and GCK-VN for one key. One PDU allows the MS to give the SwMI the status of 31 GCKs. If the MS possesses more than 31 GCKs, it shall send further U-OTAR Key Status Response PDUs containing the extra GCKs. If the MS does not possess any GCKs, it shall set the "Number of GCK status" element to "0" and shall not provide any "GCK data" element.

If the SwMI requests the status of the GSKO in the MS, the MS shall respond indicating how many GSKO versions it is providing data for in the "Number of GSKO status" element, and shall provide this number of "GSKO-VN" elements, each containing GSKO-VN for one key. One PDU allows the MS to give the SwMI the status of 3 GSKO-VNs. If the MS possesses more than 3 versions of GSKO, it shall send further U-OTAR Key Status Response PDUs containing the extra GSKO-VNs. If the MS does not possess any GSKOs, it shall set the "Number of GSKO status" element to "0" and shall not provide any "GSKO-VN" element.

If the SwMI sends the request to a group of MSs, each MS shall respond on expiry of random timer T371. The SwMI shall send the maximum value of T371 to the MS in the request PDU. If the request is sent to an individual MS, the "max response timer value" shall be set to "0". If the MS needs to detach from the SwMI before sending the status response to the SwMI, it shall consider T371 to have expired and shall send the acknowledgement before detaching. T371 is described in clause 4.5.2.3. If the MS is unable to send the response PDU before detaching, it should store the PDU and send it next time it attaches to the SwMI, even if it is switched off and on again in the meantime.

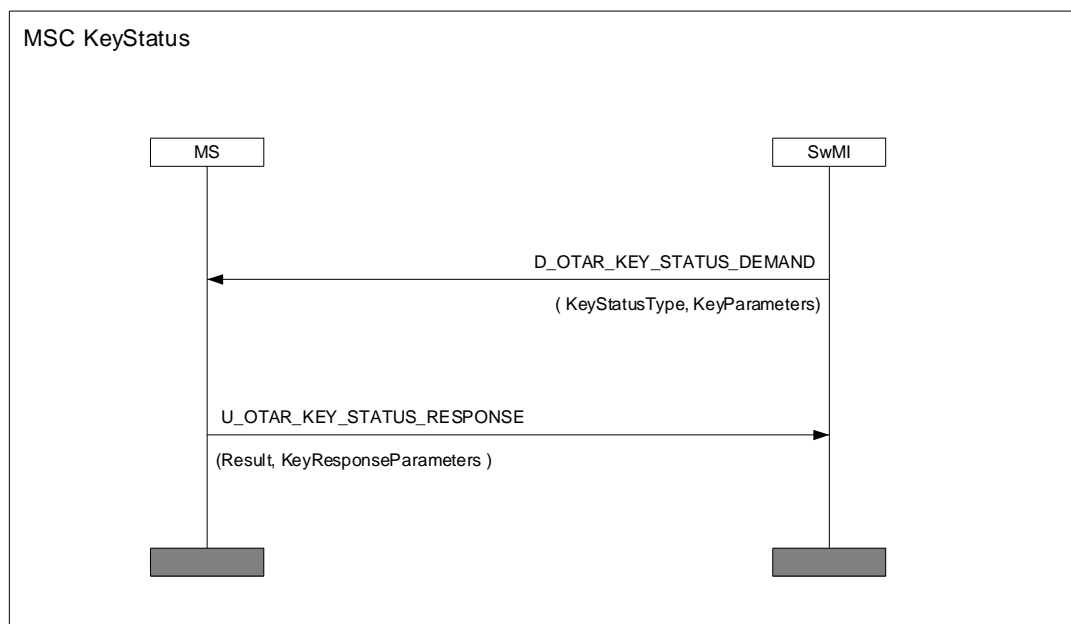

Figure 38b: Message sequence chart of key status inquiry

4.5.11 Crypto management group

Use of CMG is optional but if used shall be as defined in this clause.

A set of MSs with common key material (SCKs, GCKs) shall be considered to be part of the same Crypto Management Group (CMG), and to reduce the load at the air interface, group addressed OTAR signalling shall be sent to the CMG as a whole. The group address may be provisioned over the air interface using the method described in this clause.

The CMG has the following attributes:

- common set of key material (SCKs, GCKs);
- common key encryption key (GSKO);
- common means of addressing for group addressed OTAR (i.e. common GSSI programmed specifically for key management purposes).

An MS shall be a member of zero or only one CMG.

TM-SCK and GCK identities (SCKN and GCKN) are unique per system irrespective of the number of CMGs in use. If CMGs exist on a system DM-SCK identities (SCKN) are unique per CMG, else per system.

To make use of the CMG the MS shall be provided with a GTSI for use with group addressed OTAR. The SwMI may provide this to the MS using D-OTAR CMG GTSI PROVIDE PDU or within D-OTAR GSKO PROVIDE PDU. The SwMI shall only send these PDUs to an individually addressed MS, and it shall not send these PDUs to a group of MSs. The MS shall respond using U-OTAR CMG GTSI RESULT PDU or U-OTAR GSKO RESULT PDU respectively. The MS shall then act upon OTAR messages sent to this group, as well as to messages sent to the MS's ITSI. It shall ignore OTAR sent to any other group address.

The GTSI used for CMG purposes shall be considered long term and maintained in the MS even when powered down and up again.

If the SwMI wishes to delete the GSSI in the MS, it shall set the "GSSI" element to "0".

If the MS receives a CMG GTSI from the SwMI that is different to that already stored, or if the SwMI deletes the CMG GTSI from the MS, then the MS shall delete all previously stored DMO SCK (i.e. where $1 \leq \text{SCKN} \leq 30$), GCK and GSKO material. The fallback SCK for TMO (SCKN = 31 or SCKN = 32) should not be deleted.

4.5.12 OTAR retry mechanism

When registered on a cell, the MS shall monitor the OTAR Retry Interval element setting, conveyed through transmissions of SCK, GSKO and GCK OTAR Provide PDUs, in order for the MS to determine how many hyperframes it shall wait before retrying an OTAR Demand for SCK, GSKO or GCK. The SwMI shall also indicate the current OTAR retry interval setting in SCK, GCK and GSKO Reject PDUs. The last received OTAR retry interval always applies on the serving cell irrespective of whether it arrived in a Provide or Reject PDU.

When the OTAR Retry Interval expires in the MS, the MS shall wait a further random number of random access signalling slots before retrying the OTAR Demand PDU. The procedure for randomly selecting the signalling slot shall follow the procedure for "Choosing from a new access frame" as defined in EN 300 392-2 [2], clause 23.5.1.4.6.

The OTAR Retry Interval setting shall only have relevance to the cell on which it is broadcast; cells that comprise the same SwMI may use different settings. In the absence of any indication of the cell's OTAR Retry Interval setting, the MS shall default to using a setting of "Do not retry". However, if the MS subsequently receives a different OTAR Retry Interval setting from the SwMI, whilst one or more key requests are outstanding, then the MS shall retrospectively apply the newly received setting.

Following cell re-selection, and registration on the new serving cell, the MS may re-request key(s) that are needed and, thereafter, wait the appropriate length of time given by the new serving cell (as previously stated) before retrying its OTAR Demand for SCK, GSKO or GCK. In the absence of any indication of the new serving cell's OTAR Retry Interval setting, the MS shall default to using a setting of "Do not retry".

4.5.13 OTAR protocol functions – GSKO

A single GSKO may be distributed to the MS using the "D-OTAR GSKO Provide" PDU, sealed with KSO. The provision may be started automatically by the SwMI or in response to a request from the MS using the "U-OTAR GSKO Demand" PDU. The "D-OTAR GSKO Provide" PDU shall also include the GSSI of the Crypto Management Group to which the MS can expect group addressed OTAR relevant to that MS to be addressed. The "D-OTAR GSKO provide" PDU shall be individually addressed to the MS, and the MS shall respond with a "U-OTAR GSKO Result" PDU.

If the CMG GSSI provided in the OTAR Provide PDU is different to its previously stored CMG GSSI, the MS shall delete the stored GCKs and DMO-SCKs as described in clause 4.5.11.

4.5.13.1 MS requests provision of GSKO

The scenario in figure 38c shows the case where the MS requests provision of a GSKO. The MS may initiate this procedure at any time.

The MS may send a U-OTAR GSKO Demand PDU to the SwMI. The "address extension" element may be used to indicate the network for which the GSKO is valid if different from the current serving network of the MS.

The SwMI shall respond with the requested GSKO using the D-OTAR GSKO Provide PDU, together with the CMG GSSI and GSKO-VN information. The SwMI may indicate the network for which the GSKO and GSSI is valid using the "address extension" element if the network for which the GSKO is valid is different to the serving network of the MS. The MS shall respond and inform the SwMI of the success or failure of the OTAR using the U-OTAR GSKO Result PDU. In case of failure, it shall indicate the reason, which may include failure to decrypt key, or SwMI provided the wrong key.

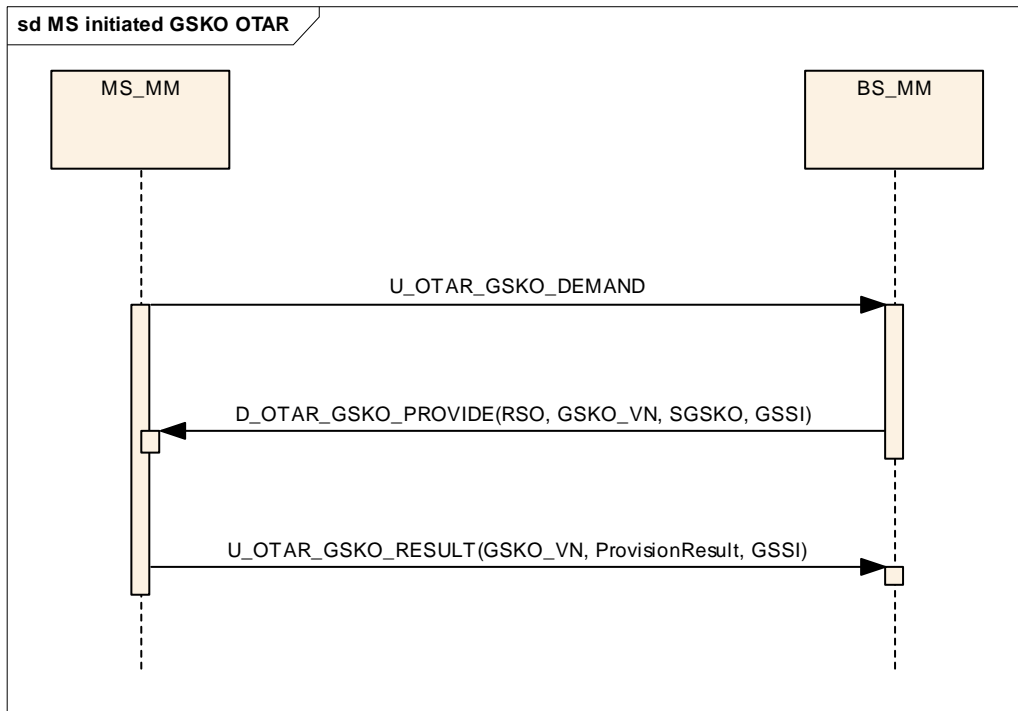

Figure 38c: GSKO delivery initiated by MS

4.5.13.2 SwMI provides GSKO to an MS

The scenario in figure 38d shows the case where the SwMI provides a GSKO to an MS without the MS first requesting GSKO provision. The SwMI may initiate this procedure at any time. The SwMI shall provide the GSKO to the MS using the D-OTAR GSKO Provide PDU which includes the CMG GSSI and GSKO-VN information. The MS shall respond and inform the SwMI of the success or failure of the OTAR using the U-OTAR GSKO Result PDU. In case of failure, it shall indicate the reason.

The normal message sequence in this case shall be according to figure 38d.

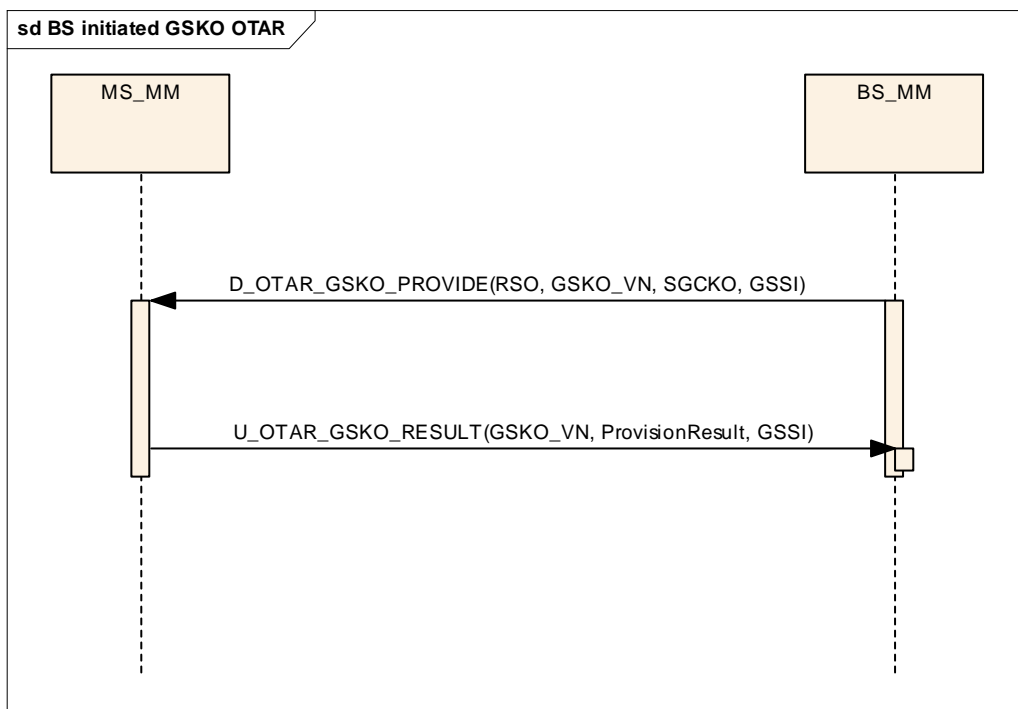

Figure 38d: GSKO delivery initiated by SwMI

4.5.13.3 SwMI rejects provision of GSKO

If the SwMI is unable to provide a GSKO the provision request shall be explicitly rejected using the D-OTAR GSKO Reject PDU indicating the reason for rejection. The SwMI shall indicate to the MS how long the MS shall wait before retrying a request for GSKO by setting the value of the "OTAR retry interval" element. The behaviour of the MS shall be as described in clause 4.5.12.

5 Enable and disable mechanism

NOTE: Without authentication capability in the MS it is possible that a SwMI (real or false) can temporarily deny service to the MS, if the MS supports temporary enable/disable. The use of authentication embedded into the enable/disable mechanism as described in this clause minimizes this risk.

An MS moving from DMO to TMO, or from TMO to DMO, shall retain its disabled state. Thus if an MS is disabled in TMO it shall remain disabled even if the user attempts to switch to DMO.

5.1 General relationships

Figure 39 shows the relationship of subscription, identified by ITSI, and the hardware of the MS, identified by TEI. The TEI is fixed and associated with the hardware of the MS. The subscription, identified by ITSI, may be contained in a separable module. If ITSI is not contained in a separable module, it may still be changed by, for example, field programming equipment.

If a SIM is used to store the ITSI the procedures described in EN 300 812 [4], clause 11.4.4 shall be enforced in addition to the protocols described in this clause.

ITSI and TEI are described in EN 300 392-1 [1], clause 7.

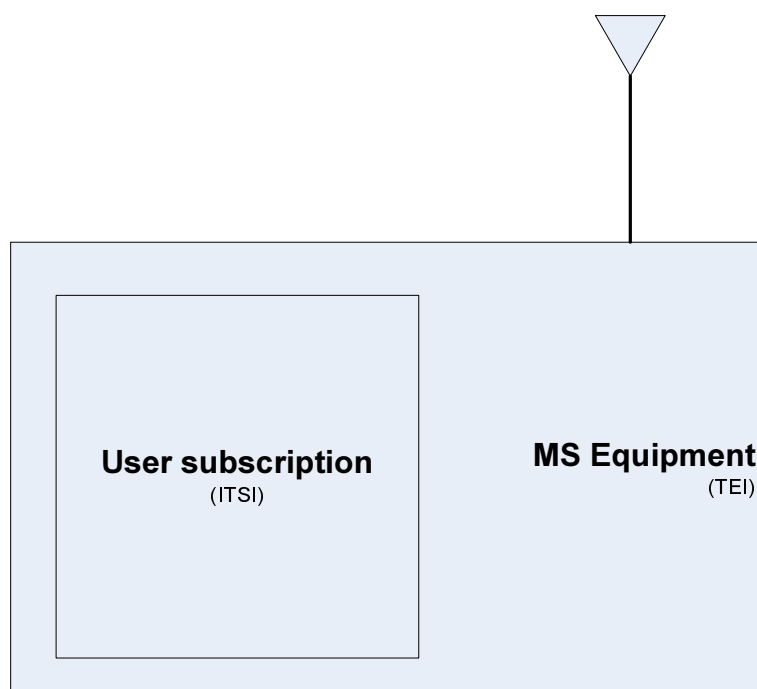

NOTE: The ITSI may be held in a removable user information module, e.g. SIM.

Figure 39: Relationship of TEI and ITSI in MS

5.2 Enable/disable state transitions

Figure 40 shows all possible enabled and disabled states of one pair of MS equipment and ITSI and the transitions between the states. This diagram does not show state transitions due to separation of ITSI from, or fitting of ITSI into, an MS equipment.

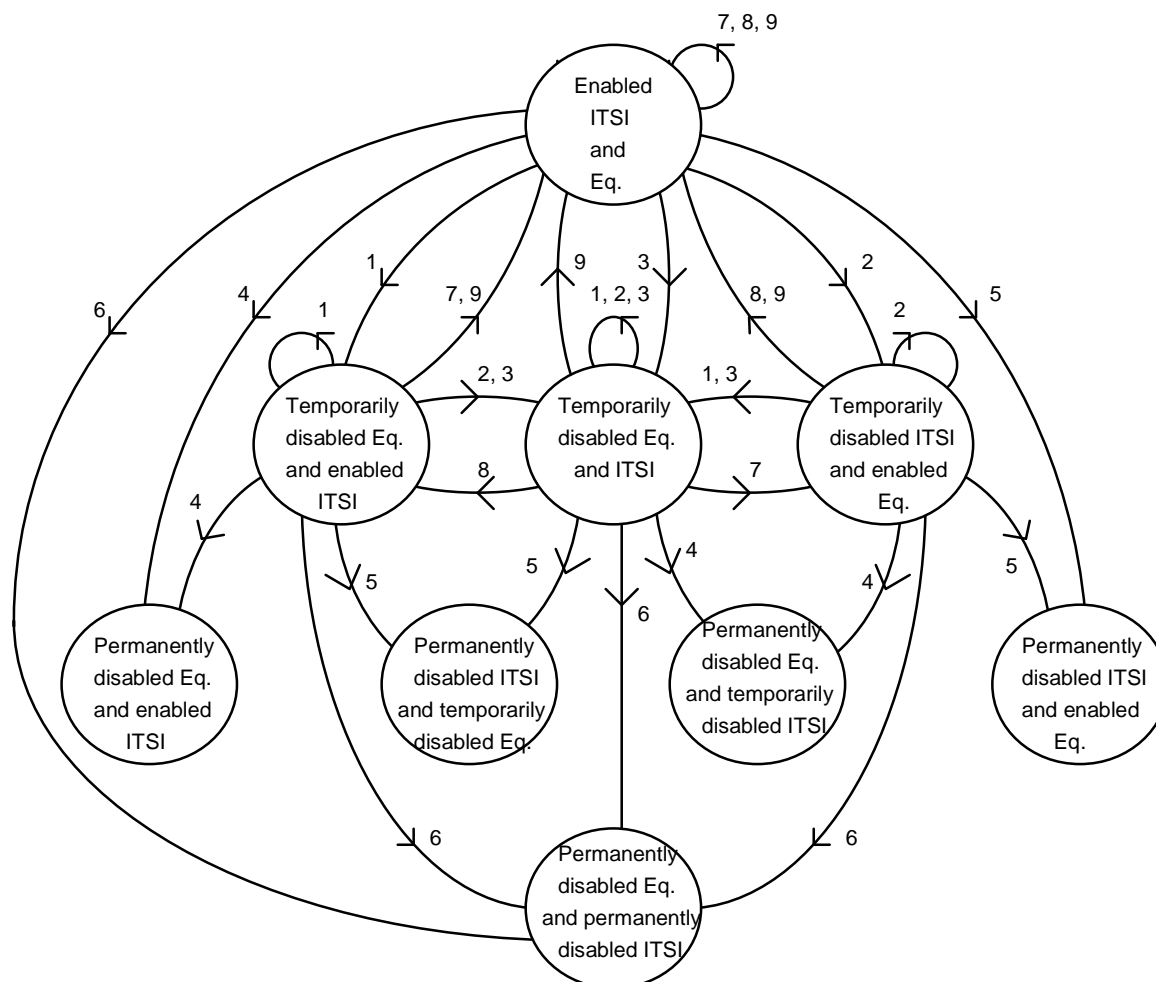

KEY:

- 1) temporary disabling of equipment;
- 2) temporary disabling of ITSI;
- 3) temporary disabling of equipment and ITSI;
- 4) permanent disabling of equipment;
- 5) permanent disabling of ITSI;
- 6) permanent disabling of equipment and ITSI;
- 7) enabling of equipment;
- 8) enabling of ITSI;
- 9) enabling of equipment and ITSI.

Figure 40: State transitions of enable/disable mechanism

5.3 Mechanisms

An MS and SwMI operating in security class 3 or security class 2 shall perform enabling and disabling with encryption applied. An MS and SwMI operating in security class 1 shall perform enabling and disabling in clear. If authentication is required by the SwMI it shall be applied for enable and disable operations by the inclusion of an authentication challenge in the D-DISABLE or D-ENABLE PDU.

The rules for when the MS may reject an enable/disable command are described in clause 5.4.6.

In cases where authentication has been initiated by the SwMI it may be made mutual by the MS.

There are nine possible transactions necessary for the enable/disable procedures which allow disable and enable of the MS equipment, the subscription, or both. These are detailed in clauses 5.3.1 to 5.3.6 in which the temporary and permanent distinctions are amalgamated.

There may be other mechanisms that withdraw service or disable the equipment that are outside the scope of the present document.

Equipment or subscriptions that have been temporarily disabled may be enabled by the enable mechanisms described in clauses 5.3.4 to 5.3.6. Equipment or subscriptions that have been permanently disabled shall not be enabled by these mechanisms.

5.3.1 Disable of MS equipment

The MS equipment shall be disabled by the SwMI either temporarily or permanently in such a manner that it shall enter the disabled state, and remain disabled even if a separable module is used to contain the ITSI, and that module is changed. If the ITSI is contained in a separable module, it may be detached and connected to a different MS equipment; and may then operate providing that the new MS equipment has not also been disabled.

5.3.2 Disable of an subscription

The subscription shall be disabled by the SwMI either temporarily or permanently. If the ITSI is contained in a separable module, and this module is then connected to a different MS equipment, the composite MS shall remain disabled. The MS equipment shall operate if a different module containing a subscription containing ITSI that has itself not been disabled is connected.

5.3.3 Disable of subscription and equipment

The MS equipment and its subscription shall be disabled by the SwMI either temporarily or permanently in such a manner that neither the separable module nor the MS equipment shall individually function even if the module is connected to a different MS equipment, or the MS equipment is connected to a different module.

5.3.4 Enable an MS equipment

The MS shall be capable of receiving enable commands addressed individually with a valid L2 address for the MS, i.e. ISSI/ASSI in the home network and ITSI/(V)ASSI in a visited network (during migration). The PDU shall include the TEI of the MS equipment. Only MS equipment that has been temporarily disabled may be enabled by this method: if the MS subscription has also been disabled, whether the ITSI is contained in a separable module or not, it shall not be enabled by this mechanism.

5.3.5 Enable an MS subscription

The MS shall be capable of receiving enable commands addressed individually with a valid L2 address for the MS, i.e. ISSI/ASSI in the home network and ITSI/(V)ASSI in a visited network (during migration). The PDU shall not include the TEI of the MS equipment. Only an MS subscription that has been temporarily disabled may be enabled by this method: If the MS equipment has also been disabled, whether the ITSI is contained in a separable module or not, the composite MS shall not be enabled solely by this mechanism.

5.3.6 Enable an MS equipment and subscription

The MS equipment and subscription shall be enabled using commands addressed to a valid L2 individual address for the MS, i.e. ISSI/ASSI in the home network and ITSI/(V)ASSI in a visited network (during migration), whether the subscription or equipment has previously been disabled, or both. Equipment, or subscriptions, or both, that have been temporarily disabled may be enabled by this mechanism. The PDU shall include the TEI of the MS equipment.

Where the ITSI is not separable, an MS may be disabled by utilizing any of the mechanisms described in clauses 5.3.1 to 5.3.3. However, to re-enable an MS the SwMI shall use the corresponding mechanism or a mechanism including it. Therefore, an MS temporarily disabled using the mechanism described in clause 5.3.1 shall only be enabled using the mechanisms described in clauses 5.3.4 or 5.3.6; an MS disabled by the mechanism described in clause 5.3.2 shall only be enabled by the mechanisms described in clauses 5.3.5 or 5.3.6; and an MS disabled by the mechanism described in clause 5.3.3 shall only be enabled by the mechanism described in clause 5.3.6.

5.4 Enable/disable protocol

5.4.1 General case

NOTE 1: An MS operating in transmission inhibit mode (for example operating in radio transmission free environments such as hospitals) may be unable to transmit the protocol responses required below. In such cases the behaviour of the MS is determined by system policy (e.g. to be permitted to act on the received command without response).

All signalling should be individually addressed. The SwMI may need to know the ITSI/TEI binding, where necessary this may be obtained using the ITSI-TEI mapping at registration. Confirmation of the target for disabling and enabling is then provided by including the ITSI and/or TEI of the MS in the PDUs. If the SwMI supports authentication, it should authenticate the MS to ensure that it is obtaining a response from the correct MS. The MS should also authenticate the SwMI when possible to validate the instruction. The authentication protocol and PDUs are contained in clause 4.

The protocol shall be required to complete before the MS changes its state. If the protocol transaction does not complete (unless the failure was due to authentication failure), the MS shall indicate its unchanged state to the SwMI.

The TEI when included in PDUs is not protected by any specific cryptographic sealing mechanism. It should therefore only be provided when encryption parameters have been established, and air interface encryption is operating on a cell of class 2 or 3 as described in clause 6.

NOTE 2: It is recommended that the TEI is not transferred across the air interface in class 1 cells.

The enabling and disabling is enacted by the primitives MLE-CLOSE, MLE-DEACTIVATE request and MLE-OPEN. The MLE-CLOSE primitive used in the context of temporary disable to indicate that access to the communication resources has been closed to the other higher layer entities: SNDPCP and CMCE. If the disabling is temporary the MS shall remain disabled in the sense that access to the communication resources shall remain closed for the CMCE and SNDPCP entities. MM should remain active so that any roaming (or associated security) functions continue to operate, in order to allow the MS to receive an enable instruction. Should the MS be powered down the MS shall retain the information that it is temporarily disabled.

In the temporarily disabled state the MS shall disable the MMI in order to prevent the user making any change to the state of the MS and also to prevent the user being able to derive any knowledge of the operation of the MS.

In the temporarily disabled state the MS shall not be able to invoke any function of the CMCE and SNDPCP entities.

EXCEPTION: For the purpose of supporting the Supplementary Service Ambience Listening the SwMI may be able to invoke the relevant CMCE entities.

The MS shall not invoke any OTAR function for SCK and GCK by any method in the temporarily disabled state. In a permanently disabled state the disabling of all radio functions shall be carried out using the MLE-DEACTIVATE request. This shall be used by the MM entity to request the de-activation of all MLE procedures and to return to the NULL state. No communication resources are available for use after this primitive has been issued. It shall not be possible to reverse the permanent disable state by user intervention or by a TETRA protocol.

5.4.2 Status of cipher key material

5.4.2.1 Permanently disabled state

In the event of permanent disable of an ITSI all key material including K shall be permanently deleted such that it cannot be recovered.

In the event of permanent disable of an equipment (TEI) all key material maintained on the equipment (including K if present) shall be permanently deleted such that it cannot be recovered. If a SIM is fitted entry to the permanently disabled state should not delete key material on the SIM.

NOTE: A SIM is intended to store material directly related only to an ITSI.

It is advised that where possible as a result of permanent disable the algorithms belonging to the algorithm set TAA1 and any TETRA encryption algorithms (TEAx) should be permanently deleted.

Table 6.3: Summary of Permanent Disable

Identity module	Disable target	Normal operating security class	Post disable key state
Non-detachable	TEI/ITSI	All	permanently delete all
		2	
		1	
Detachable	TEI	All	permanently delete all material residing in the equipment
		2	
		1	
Detachable	ITSI	All	permanently delete all material residing in the SIM
		2	
		1	

5.4.2.2 Temporarily disabled state

In the event of temporary disable of an ITSI in class 3 networks all shared long lifetime key material (GCK, SCK where $1 \leq \text{SCKN} \leq 30$, GSKO) and CMG GTSI should be permanently deleted. The fallback SCK for TMO (SCKN = 31 or SCKN = 32), and K should not be deleted. For class 2 networks SCKs used in TMO shall be retained to allow the enable protocol to work.

In the event of temporary disable of an equipment (TEI) in class 3 networks all shared long lifetime key material (GCK, SCK where $1 \leq \text{SCKN} \leq 30$, GSKO) and CMG GTSI should be permanently deleted. The fallback SCK for TMO (SCKN = 31 or SCKN = 32), and K should not be deleted. For class 2 networks SCKs used in TMO shall be retained to allow the enable protocol to work.

In a class 3 network in order to maintain MM functionality (required for the enable protocol to work and to allow the location update protocol to work) the following keys shall be retained: DCK; CCK.

Table 6.4: Summary of Temporary Disable

Identity module	Disable target	Normal operating security class	Post disable key state
Non-detachable	TEI/ITSI	3	Retain DCK, CCKs, K, SCK31, SCK32
		2	Retain TMO SCKs, K
		1	Retain K
Detachable	TEI	3	Retain DCK, CCKs, K, SCK31, SCK32
		2	Retain TMO SCKs, K
		1	Retain K
Detachable	ITSI	3	Retain DCK, CCKs, K, SCK31, SCK32
		2	Retain TMO SCKs, K
		1	Retain K

5.4.3 Specific protocol exchanges

The normal message exchanges for the various cases shall be according to clauses 5.4.3.1 to 5.4.3.3.

The MS shall send U-DISABLE STATUS even if there is no resulting change in state of the MS arising from the ENABLE or DISABLE request. Even when no change in state occurs, the complete protocol, including authentication where required, shall be followed.

5.4.3.1 Disabling an MS with mutual authentication

The scenario in figure 41 shall apply for MS and SwMI where the SwMI enforces authentication and the MS and SwMI supports mutual authentication. The authentication mechanisms and PDUs are described in clause 4 of the present document. The MSC shows as optional the key change procedure described in clause 4.5.5.1 which shall be considered mandatory for class 3 cells. The use of MLE-DEACTIVATE is shown as optional and shall apply when the disabling type is permanent.

Figure 41 shows the message sequence for this case.

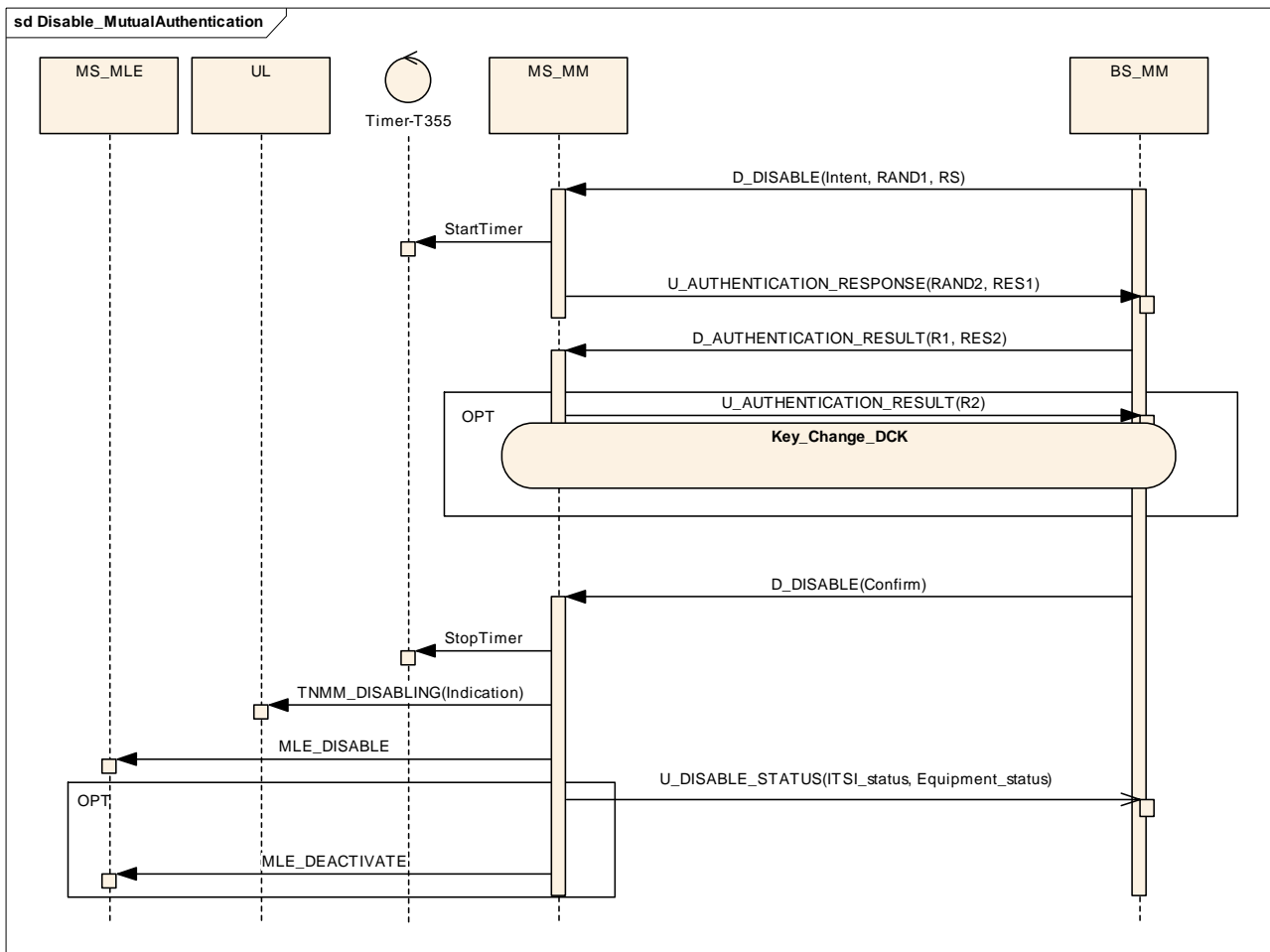

Figure 41: Disabling an MS with mutual authentication

5.4.3.2 Enabling an MS with mutual authentication

The scenario in figure 42 shall apply for MS and SwMI where the SwMI enforces authentication and the MS and SwMI supports mutual authentication. The authentication mechanisms and PDUs are described in clause 4 of the present document. The MSC shows as optional the key change procedure described in clause 4.5.5 which shall be considered mandatory for class 3 cells.

Figure 42 shows the message sequence for this case.

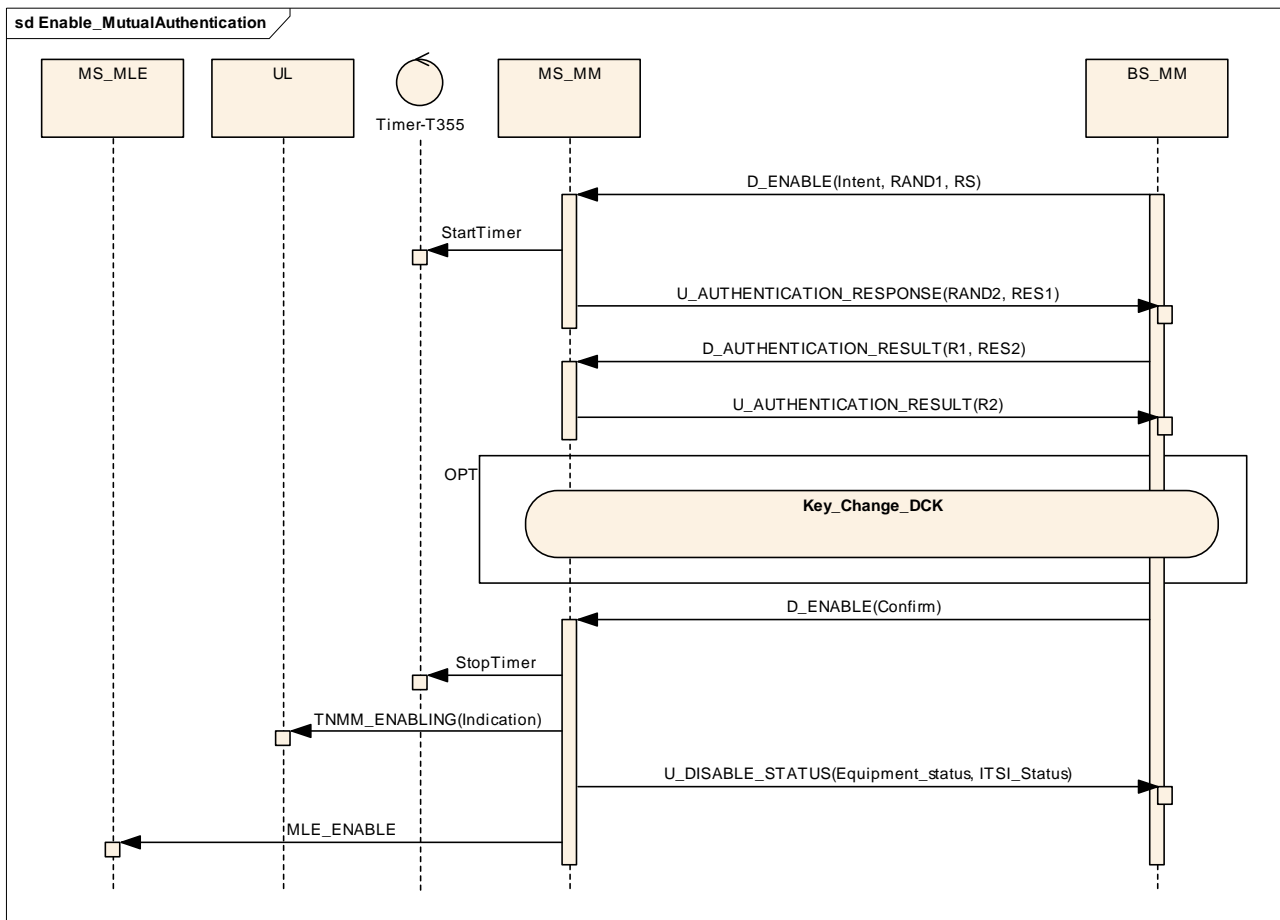

Figure 42: Enabling an MS with authentication

5.4.3.3 Enabling an MS with non-mutual authentication

The scenario in figure 42a shall apply for MS and SwMI where the SwMI enforces authentication but the MS does not support mutual authentication. The authentication mechanisms and PDUs are described in clause 4 of the present document. The MSC shows as optional the key change procedure described in clause 4.5.5.1 which shall be considered mandatory for class 3 cells.

Figure 42a shows the message sequence for this case.

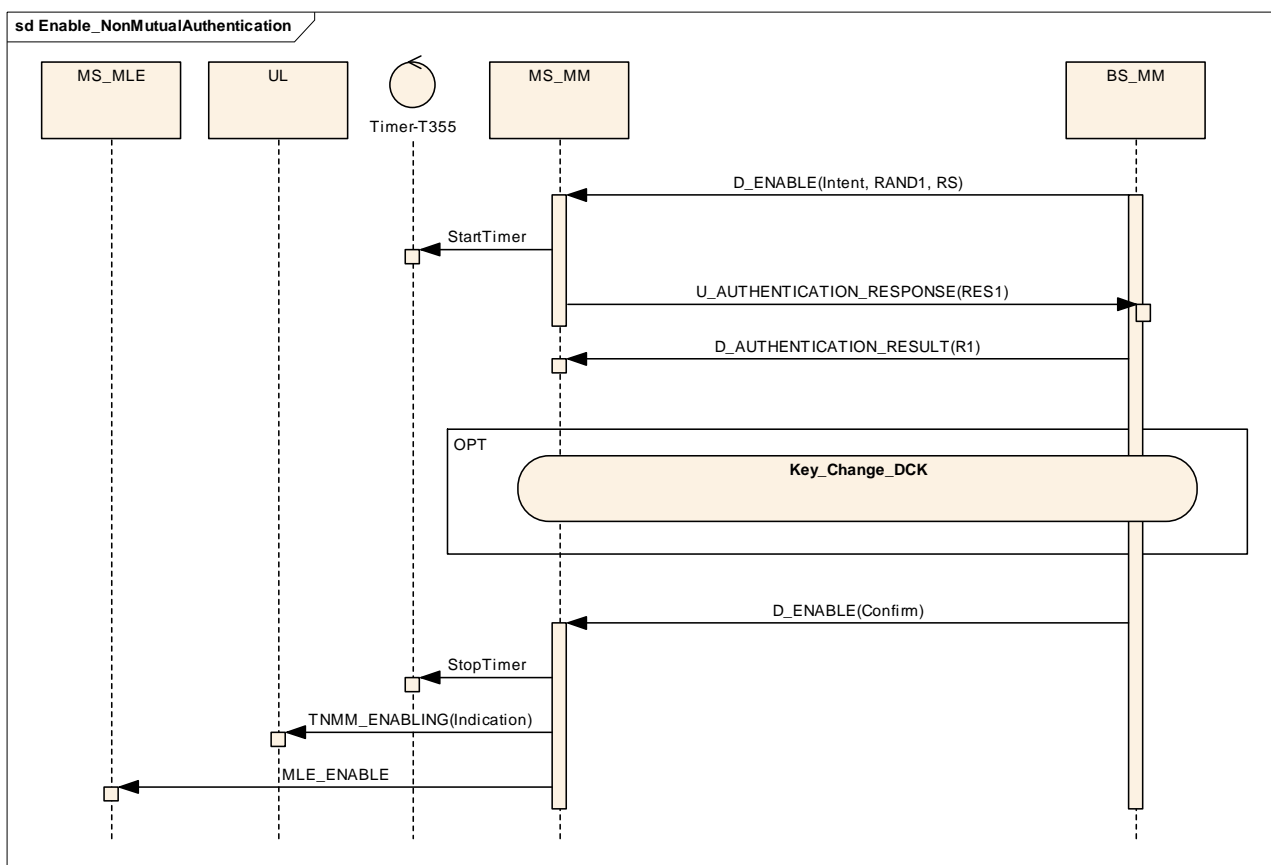

Figure 42a: Enabling an MS with non-mutual authentication

5.4.3.4 Disabling an MS with non-mutual authentication

The scenario in figure 42b shall apply for MS and SwMI where the SwMI enforces authentication but the MS does not support mutual authentication. The authentication mechanisms and PDUs are described in clause 4 of the present document. The MSC shows as optional the key change procedure described in clause 4.5.5 which shall be considered mandatory for class 3 cells. The use of MLE-DEACTIVATE is shown as optional but shall apply when the disabling type is permanent.

Figure 42b shows the message sequence for this case.

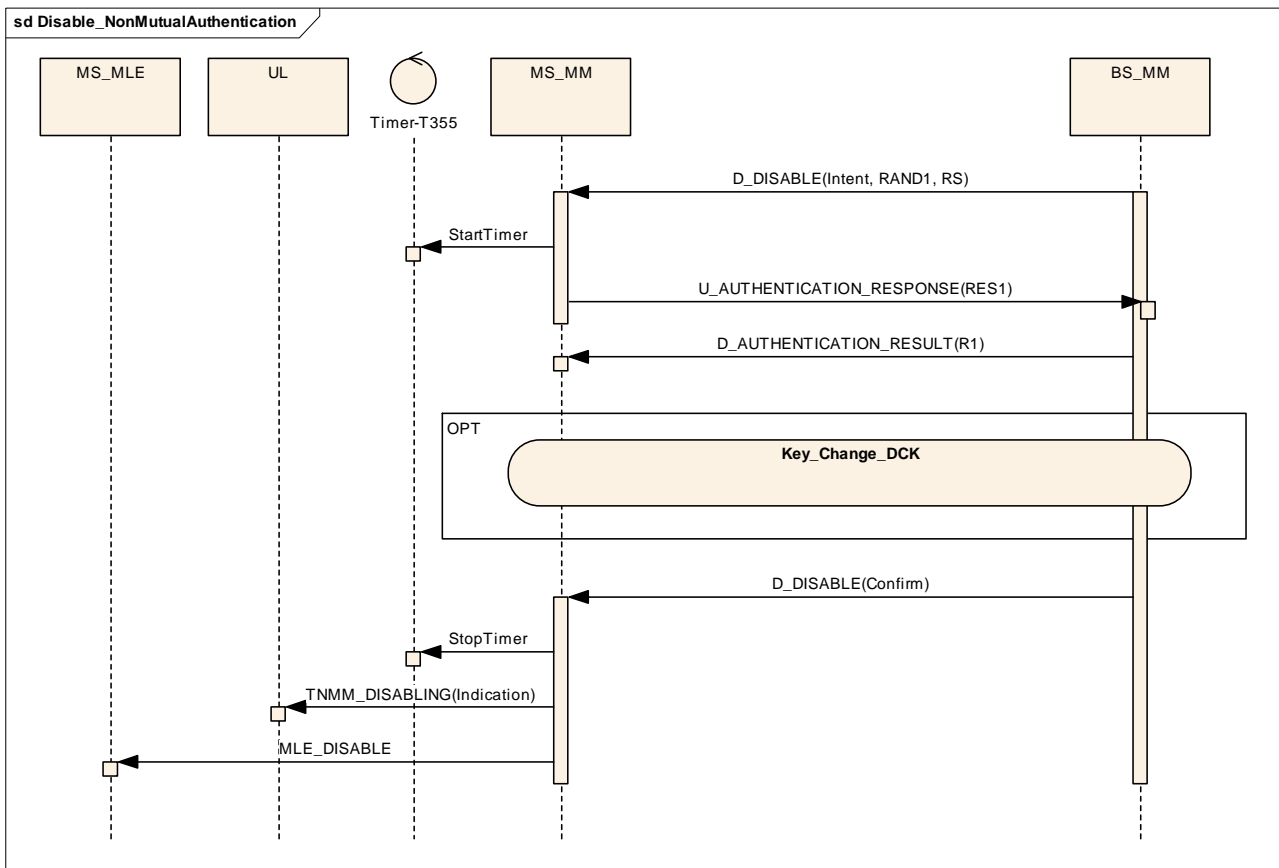

Figure 42b: Disabling an MS with non-mutual authentication

5.4.4 Enabling an MS without authentication

The scenario in figure 43 shall apply for MS and SwMI where the SwMI does not enforce authentication.

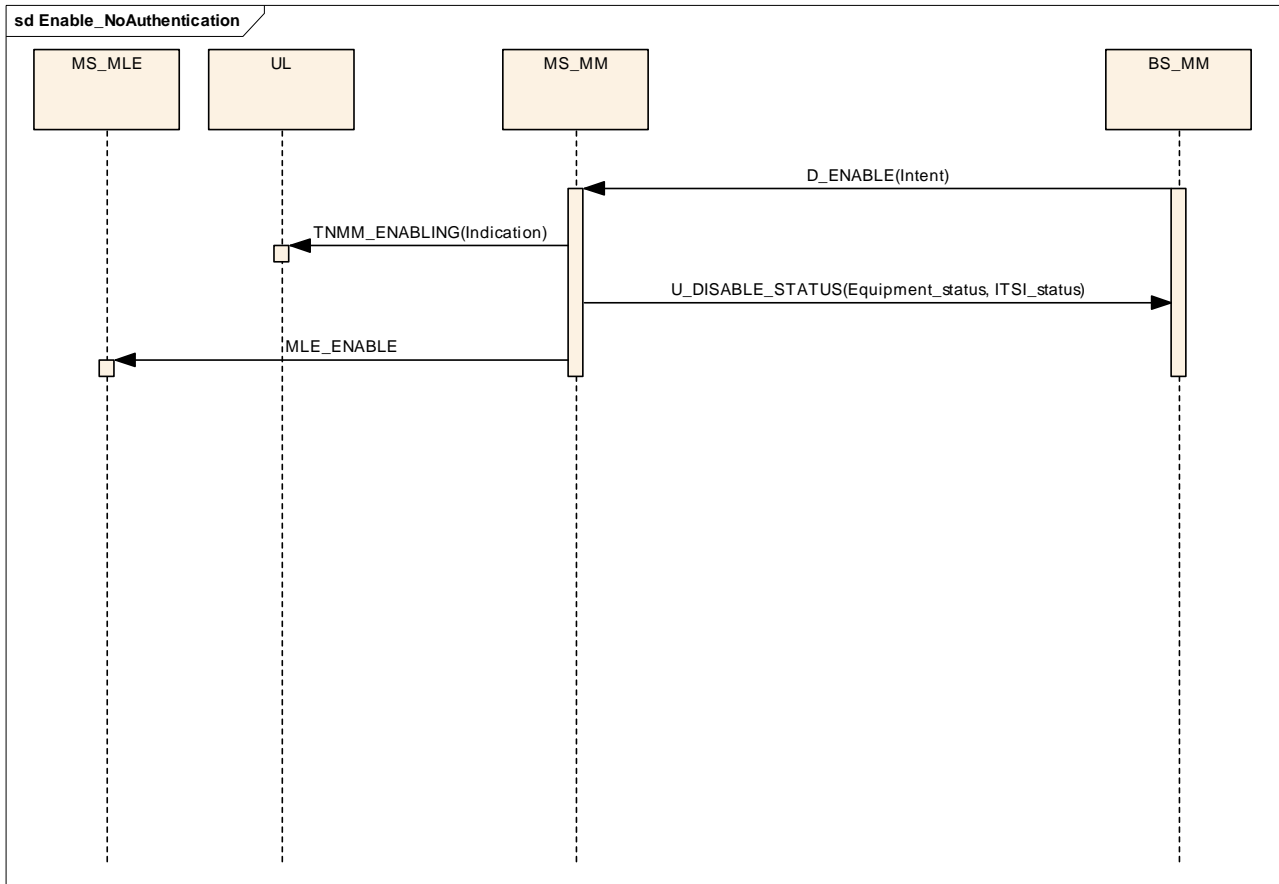

Figure 43: Enabling an MS without authentication

5.4.5 Disabling an MS without authentication

The scenario in figure 44 shall apply for MS and SwMI where the SwMI does not enforce authentication.

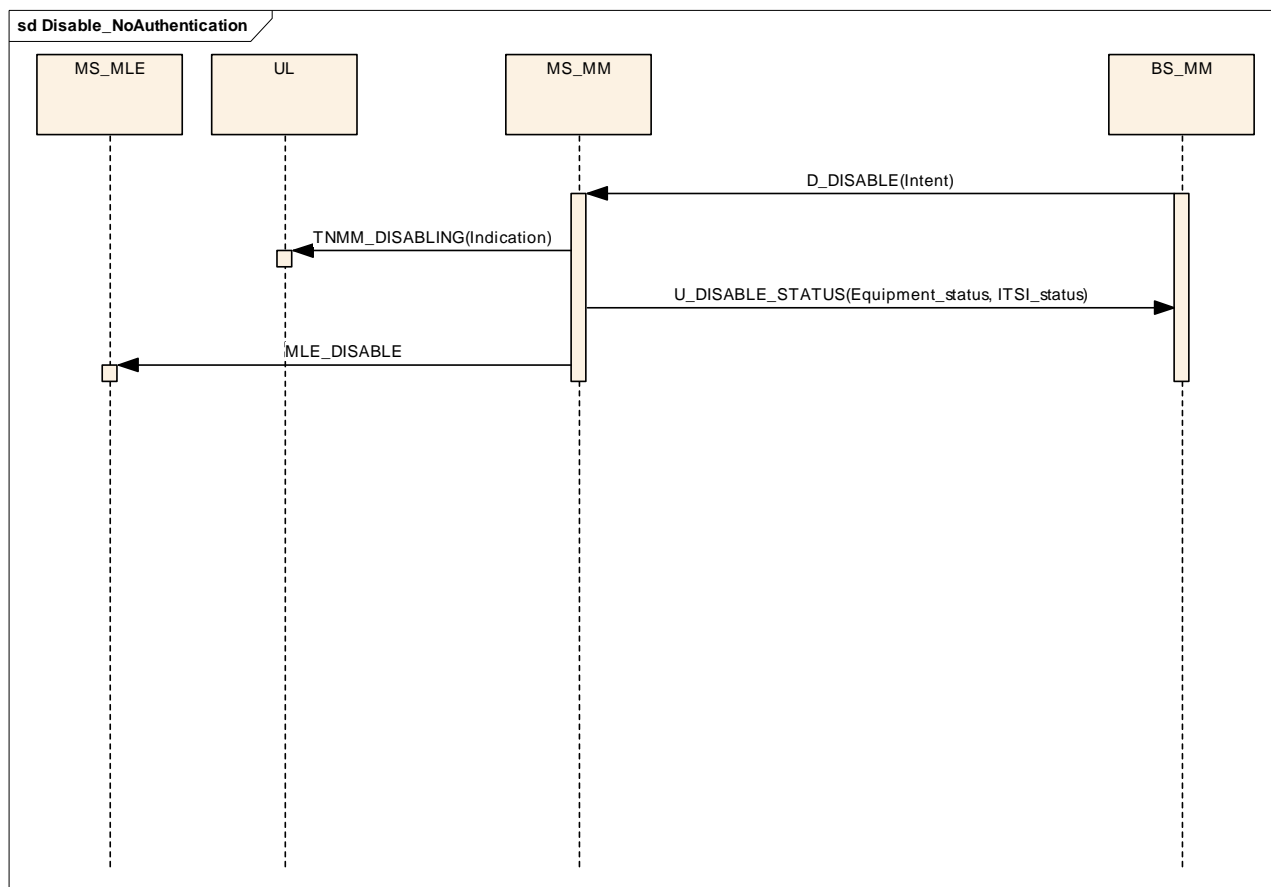

Figure 44: Disabling an MS without authentication

5.4.6 Rejection of enable or disable command

NOTE: Local security policy determines the behaviour required from the system.

An MS which receives an enable or disable command for a function which it does not support should reject the enable or disable command with the message "MM PDU NOT SUPPORTED".

An MS which supports enable/disable and encryption should reject an unencrypted enable/disable command with the reason "encryption is required" in the U-DISABLE STATUS PDU.

An MS which supports enable/disable, but does not support authentication, should reject an enable/disable command which includes authentication with the reason "authentication not supported" in the U-DISABLE STATUS PDU.

An MS which supports enable/disable and enforces mutual authentication should reject an enable/disable command which does not include authentication with the reason "authentication required" or "authentication and encryption are required" in the U-DISABLE STATUS PDU.

An MS which supports enable/disable should reject an enable/disable command directed at a TEI which does not match the TEI of the MS with the reason "TEI mismatch" in the U-DISABLE STATUS PDU.

If authentication of either party fails, the transaction shall terminate following transmission of the appropriate AUTHENTICATION RESULT PDU, and the MS shall remain in its previous state (enabled or disabled).

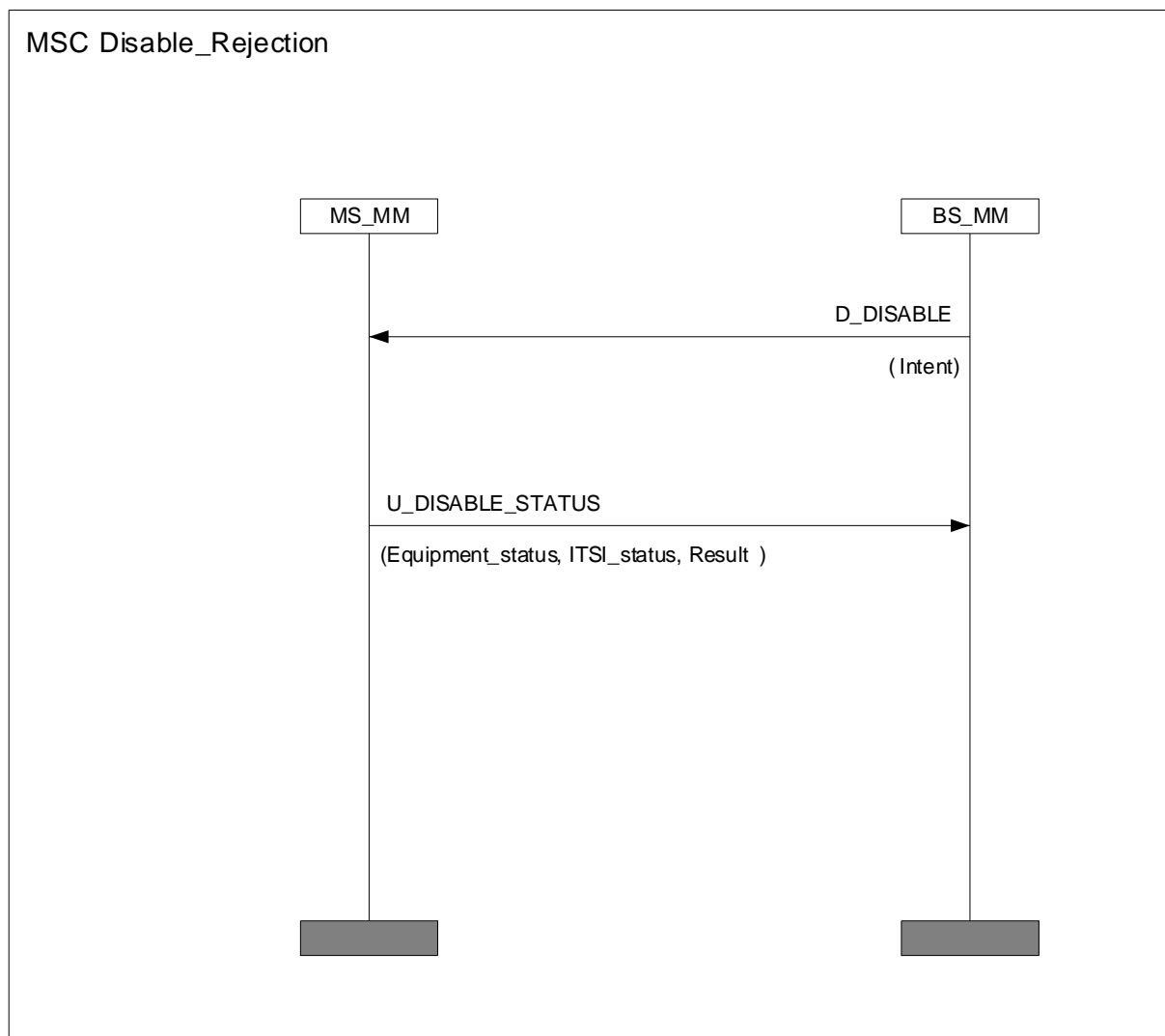

Figure 45: Rejection of permanent disabling by an MS without authentication

5.4.6a Expiry of Enable/Disable protocol timer

If authentication is used in the transaction, and timer T355 expires before the receipt of D-DISABLE Confirm or D-ENABLE Confirm by the MS, the MS shall revert to its previous state. The U-DISABLE Status PDU shall be sent to the SwMI with the Enable/Disable result element set to "Enable/disable failure, authentication is required". The SwMI may use this reason to deduce that the transaction has failed due to timer expiry, as the transaction did make use of authentication.

If the authentication transaction has completed before expiry of the timer, the established DCK shall follow the rules according to clause 4.5.5.1. If authentication has failed to complete, the encryption state and established DCK shall follow the rules according to clause 4.4.2.

Timer T355 is started before the authentication timer T354, and stopped after T354, and therefore shall be greater or equal in value to T354.

5.4.7 MM service primitives

MM shall provide indication to the user application when the MS has been disabled or enabled. The primitives that shall be provided are detailed in the following clauses.

5.4.7.1 TNMM-DISABLING primitive

TNMM-DISABLING indication primitive shall be used as an indication to the user application that a temporary or permanent disabling of the MS is ordered.

Table 7 defines the parameters for TNMM-DISABLING indication.

Table 7: Parameters for the primitive TNMM-DISABLING indication

Parameter	Indication
Enable/disable status	M

5.4.7.2 TNMM-ENABLING primitive

TNMM-ENABLING indication primitive shall be used as an indication to the user application that the temporary disabling of the MS is cancelled.

Table 8 defines the parameters for TNMM-ENABLING indication.

Table 8: Parameters for the primitive TNMM-ENABLING indication

Parameter	Indication
Enable/disable status	M

The parameters in the primitives may take the following values.

Table 8a: Enable/disable status values

Parameter name	Values/Options
Enable/disable status	Equipment enabled
	Subscription enabled
	Equipment and subscription enabled
	Equipment temporary disabled
	Equipment permanently disabled
	Subscription temporary disabled
	Subscription permanently disabled
	Equipment and subscription temporarily disabled
	Equipment and subscription permanently disabled

6 Air Interface (AI) encryption

6.1 General principles

AI encryption shall provide confidentiality on the radio link between MS and BS and be resident in the upper part of the MAC layer of the TETRA protocol stack, which itself is the lower part of layer 2. Situating the encryption process at this point, prior to channel coding at the transmitting end and after channel decoding at the receiving end, enables the MAC headers to be left unencrypted. This allows the appropriate channel coding to be used, enables receiving parties to determine the applicability of a message received over air for them, and enables application of the correct key for the decryption process. Figure 46 illustrates this placement.

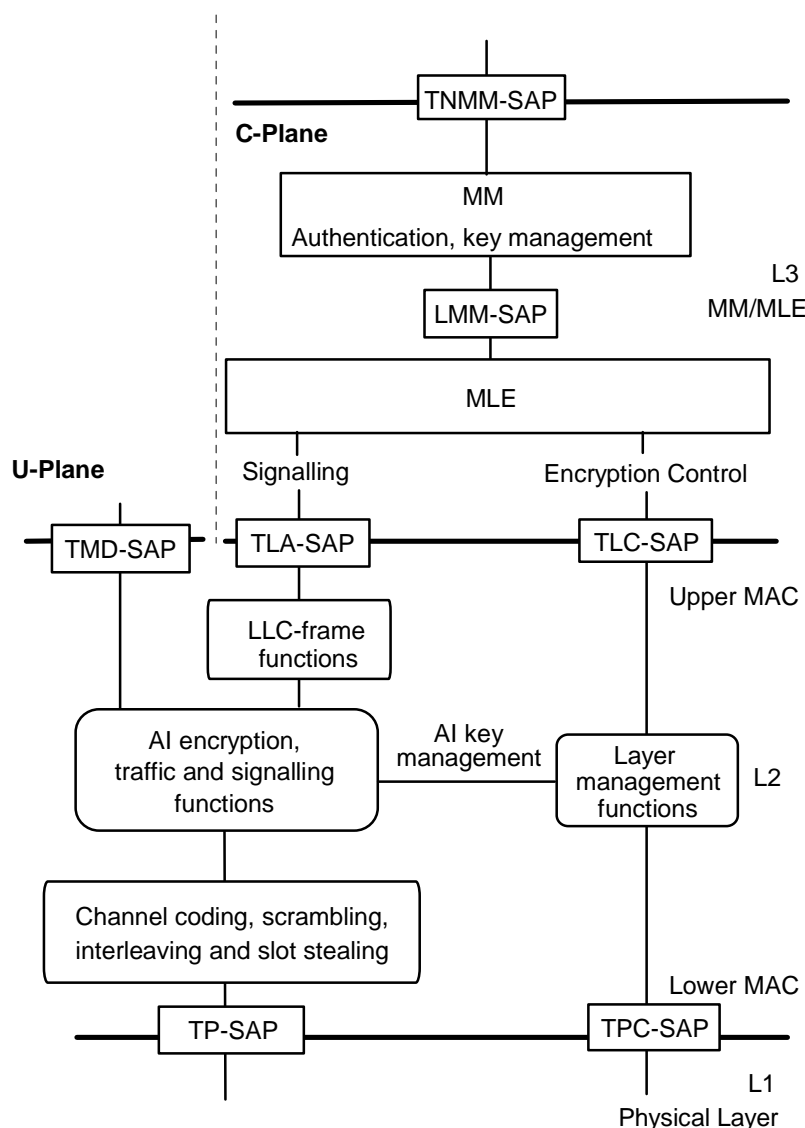

Figure 46: Relationship of security functions to layers functions in MS

If an MS and SwMI load different keys from each other, the receiving party will decode messages incorrectly. This will cause erroneous operation. The result of this, and any corrective action put in place to prevent errors, for example attempting a re-authentication to establish new keys, is outside the scope of the present document.

Air interface encryption shall be a separate function to the end-to-end encryption service described in EN 302 109 [6]. Information that has already been encrypted by the end-to-end service may be encrypted again by the air interface encryption function. Where TETRA provides for clear or encrypted circuit mode services in clause 8 of EN 300 392-1 [1], these shall be independent of air interface encryption; thus a circuit mode service invoked without end-to-end encryption may still be encrypted over the air interface.

6.2 Security class

Two encryption modes are described, each of which shall use the same encryption process:

- SCK mode: For AI encryption without enforced authentication. This mode shall use SCK for address encryption.
- DCK mode: For AI encryption where authentication is mandatory. This mode shall use CCK for address encryption, and shall also use CCK to encrypt group addressed signalling (including broadcast) and traffic alone or in combination with GCK.

Table 9 summarizes the encryption modes into a set of three security (equipment) classes. These classes apply to cells within a SwMI and may be used to classify terminal capability.

Table 9: Security classes

Class 1:	Shall not use encryption.
	May use authentication.
Class 2: SCK Mode	Shall use SCK encryption.
	Shall use ESI with SCK.
	May use authentication.
Class 3: DCK Mode	Shall use authentication.
	Shall use DCK, CCK and may use MGCK encryption (GCK in combination with CCK).
	Shall use ESI with CCK.

Table 10: Void

The present document describes a system in which all signalling and traffic within that system comply with the same security class. However, signalling permits more than one security class to be supported concurrently within a SwMI, and movements between these classes are described in the present document. The SwMI shall control the state of AI encryption.

An MS may support one, several, or all security classes. Each shall support at any one time one of the following options:

- class 1 only;
- class 2 only;
- class 2 and class 1;
- class 3 only; or
- class 3 and class 1.

Class 2 and class 3 are not permitted to be supported at the same time in any cell because of address conflicts that could arise from using short identity encryption with two different keys.

In class 3 systems post authentication all individually addressed signalling exchanges on the downlink, and all signalling exchanges on the uplink, are also implicitly authenticated by use of DCK as the encryption key. In group addressed signalling exchanges protected by MGCK implicit authentication is also provided in class 3 systems as the CCK can only be received if the MS is in possession of DCK.

6.2.0 Notification of security class

The security class and other parameters shall be broadcast by each cell in the SYSINFO element contained in the Broadcast Network Channel (BNCH) (see EN 300 392-2 [2], clause 21). The broadcast shall use the Extended Service Broadcast information element defined in EN 300 392-2 [2] table 334a and signalled by setting the "Optional Field flag" element of SYSINFO to 11₂. It should be noted that SYSINFO may not always contain security parameters as the Extended Service Broadcast element can be alternated with one or more of the following information fields: Even multiframe definition for TS mode; Odd multiframe definition for TS mode; or, Default definition for access code A. Systems employing the security provisions described in the present document should ensure regular broadcast of the security parameters.

6.2.0.1 Security Class of Neighbouring Cells

The serving cell may indicate the security class capabilities of neighbouring cells through the "Timeshare cell and AI encryption information" information element in D-NWRK BROADCAST. The MS should assume that the neighbour cells have the same security class as that of the serving cell (i.e. the network is homogenous), unless the MS is given information to the contrary through this information element.

6.2.0.2 Identification of MS security capabilities

An MS shall register to the SwMI at the highest security class mutually available to the MS and SwMI (i.e. if BS supports class 3 and class 1 MS, and the MS also supports class 3 and class 1, the MS shall register at class 3).

The MS shall use the fields present in the class of MS element (see EN 300 392-2 [2], table 167) to indicate at registration the authentication, DCK encryption and SCK encryption capabilities of the MS for security. Furthermore, when registering for SC3 operation, the MS shall use the additional fields available in the Cipher Parameters element to indicate the MS's support for TM-SCK OTAR, SDMO and DM-SCK OTAR, and GCK encryption/OTAR.

NOTE: When registering for SC2 operation, the MS is unable to indicate its support for TM-SCK OTAR, SDMO and DM-SCK OTAR, and GCK encryption/OTAR.

Table 11: Void

The TETRA Air Interface standard version number given in EN 300 392-2 [2], table 167, applies for value 000₂ to ETS 300 392-2 edition 1 [8] only. Value 001₂ shall apply to ETS 300 392-2 edition 1 [8], plus EN 300 392-7 (V2.3.1) [12]. Value 010₂ shall apply to EN 300 392-2 [2] plus EN 300 392-7 (V2.3.1) [12]. There shall be no signalling to indicate that an MS complies with ETS 300 392-7 [9], implying that ETS 300 392-7 [9] is not accepted as a valid implementation.

This edition of the present document is compatible with EN 300 392-7 (V2.1.1) [12].

6.2.1 Constraints on LA arising from cell class

In a fully operational LA, all cells should be of the same security class (see also clause 6.5.1.3 and constraints defined for periods of class change in clause 4.5.6).

6.3 Key Stream Generator (KSG)

Encryption shall be realized using an encryption algorithm implemented in a KSG.

The KSG shall form an integral part of an MS or BS.

The KSG shall have two inputs, an Initial Value (IV) and a cipher key. These parameters shall be as specified in clause 6.3.2. The KSG shall produce one output as a sequence of key stream bits referred to as a Key Stream Segment (KSS).

A separate KSS shall be produced to encrypt every timeslot for each different key to be used to encrypt PDUs in that timeslot. Sufficient length of each KSS shall be produced to encrypt those PDUs using that KSS, taking into account the rules for allocation of KSS to logical channels specified in clause 6.4.1. The bits of each KSS are labelled KSS(0), ... KSS(n-1), where KSS(0) is the first bit output from the generator and n is the number of bits output from the generator for that KSS. The bits in the appropriate KSS shall be used to encrypt or decrypt the data of the control or traffic field. On a phase modulation channel the maximum value of n shall be 432, which enables encryption of a TCH/7,2 unprotected traffic channel. On a 150 kHz QAM channel, the maximum value of n shall be 8 288.

6.3.1 KSG numbering and selection

TETRA supports both standard and proprietary algorithms. Location update signalling shall identify which algorithm is in use. Migration should only be possible if there is agreement between operators on the algorithm used.

The SwMI should only have one encryption algorithm. An MS may have more than one algorithm but shall use the algorithm indicated by the SwMI.

Table 12 shows that the values 0000₂ to 0111₂ of KSG number used in signalling shall be reserved for the TETRA standard algorithms (see also EN 300 392-2 [2], clause 16.10.29).

Table 12: KSG Number element contents

Information element	Length	Value	Remark
KSG Number	4	0000 ₂	TETRA Standard Algorithm, TEA1
		0001 ₂	TETRA Standard Algorithm, TEA2
		0010 ₂	TETRA Standard Algorithm, TEA3
		0011 ₂	TETRA Standard Algorithm, TEA4
		0100 ₂ to 0111 ₂	Reserved for future expansion
		1xxx ₂	Proprietary TETRA Algorithms

The TETRA standard algorithms are only available on a restricted basis. The management rules for these algorithms can be found at the ETSI Web Portal (<http://portal.etsi.org/dvbandca/ALGO/listtest.asp>).

Where a SwMI supports more than one encryption algorithm in class 3 systems the CCK has to be common to users of all TEA algorithms, and in class 2 systems the SCK has to be common to users of all TEA algorithms, in order for commonality of ESI. Groups of users should be differentiated by GCK in class 3 systems. Terminals shall support only one active encryption algorithm. There shall be no dynamic change of registered algorithm for MSs in a session. If there is more than one KSG in use in the SwMI, then broadcast messages should not be encrypted.

6.3.2 Interface parameters

6.3.2.1 Initial Value (IV)

The composition of the slot and frame numbering input to IV shall be as follows:

- the first two bits IV(0) and IV(1) shall correspond to the slot number, and shall take values from 0 to 3, where value 0 corresponds to slot 1, and value 3 corresponds to slot 4. IV(0) shall be the least significant bit of the slot number (EN 300 392-2 [2], clause 9.3.5);
- the next five bits IV(2) to IV(6) shall correspond to the frame number, and shall take values from 1 (00001 binary) to 18 (10010 binary). IV(2) shall correspond to the least significant bit of the frame number (EN 300 392-2 [2], clause 9.3.4);
- the next six bits IV(7) to IV(12) shall correspond to the multiframe number, and shall take values from 1 (00001 binary) to 60 (111100 binary). IV(7) shall correspond to the least significant bit of the multiframe number (EN 300 392-2 [2], clause 9.3.7);
- the next 15 bits IV(13) to IV(27) shall correspond to the 15 least significant bits of an extension that numbers the hyper-frames. These can take all values from 0 to 32 767. IV(13) shall correspond to the least significant bit of the hyper-frame numbering extension (EN 300 392-2 [2], clause 9.3.8); and
- the final bit, IV(28), shall be used to indicate the direction of transmission and shall be given the value 0 for downlink transmissions, and shall be given the value 1 for uplink transmissions.

The value of IV shall be maintained by the SwMI and broadcast on the SYNC and SYSINFO PDUs (layer 2). The value of hyper-frame (IV(13) to IV(27)) shall be broadcast to a schedule determined by the SwMI with the value of CCK-id on cells of security class 3, and with the value of SCK-VN in cells of security class 2, in the SYSINFO broadcast.

6.3.2.2 Cipher Key

The CK shall not be used directly at the air interface for encryption but shall be modified by the Colour Code (CC), LA-id and Carrier Number (CN) using algorithm TB5 (see figure 47). This shall randomize the input to the encryption algorithm amongst the carriers of a single cell and between cells in a location area.

The ciphering process shall be as shown in figure 47. A cipher key shall be used in conjunction with a KSG to generate a key stream for encryption and decryption of information at the MAC layer. It can be considered a binary vector of 80 bits, labelled ECK(0) ... ECK(79). The cipher key used for encryption and decryption of the uplink may be different from the cipher key used for encryption and decryption of the downlink, as described in clause 6.5.

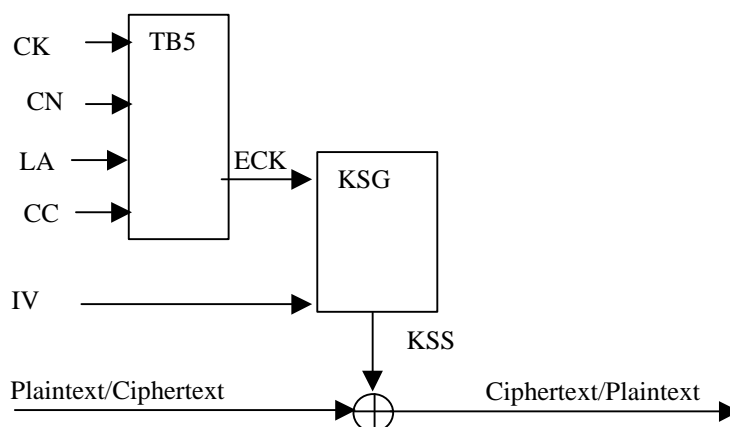

NOTE: CN of the main carrier, CC, LA-id, and initializing values of IV are received at the MS from the BS broadcast signalling messages. After initialization IV is locally generated at the MS. When camped on a cell CN values are received at the MS from downlink MAC-RESOURCE and MAC-END PDUs. IV is locally generated at the BS.

Figure 47: Speech and control information encryption

6.4 Encryption mechanism

The KSS bits shall be modulo 2 added (XORed) with plain text bits in data, speech and control channels to obtain encrypted cipher text bits, with the exception of the MAC header bits and fill bits. KSS(0) shall be XORed with the first transmitted bit of the first TM-SDU, and so on. There shall be one exception to this procedure which occurs when the MAC header includes channel allocation element data. This is described in clause 6.7.1.2.

6.4.1 Allocation of KSS to logical channels

The set of logical channels in TETRA is defined by the modulation applied. TETRA supports 3 modulation schemes each with a specific set of logical channels as shown in table 12a.

Table 12a: Logical Channels per modulation type

Modulation	Logical channel
π/4-DQPSK	TCH/2.4
	TCH/4.8
	TCH/7.2
	STCH
	TCH/S (full)
	SCH/F
	SCH/HU
	SCH/HD
	BSCH
	BNCH
π/8-D8PSK	SCH-P8/HU
	SCH-P8/HD
	SCH-P8/F
QAM	SCH-Q/RA
	SCH-Q/HU25
	SCH-Q/HU50
	SCH-Q/HU100
	SCH-Q/HU150
	SCH-Q/U25
	SCH-Q/U50
	SCH-Q/U100
SCH-Q/U150	

Modulation	Logical channel
	SCH-Q/D25
	SCH-Q/D50
	SCH-Q/D100
	SCH-Q/D150

NOTE 1: TETRA speech is only supported by $\pi/4$ -DQPSK modulated channels.
NOTE 2: QAM and $\pi/8$ -D8PSK modulations are only used for packet data and control (no circuit mode data or speech).

KSS shall be allocated to TETRA logical channels as shown in table 13. Any unused bits shall be discarded.

Table 13: KSS allocation to logical channels

Logical channel	Maximum number of bits in logical channel	KSS allocation
TCH/2.4	144	KSS(124 to 267)
TCH/4.8	288	KSS(124 to 411)
TCH/7.2	432	KSS(0 to 431)
STCH+TCH/2.4	124 + 144	KSS(0 to 123) + KSS(124 to 267)
STCH+TCH/4.8	124 + 288	KSS(0 to 123) + KSS(124 to 411)
STCH+TCH/7.2	124 + 432	KSS(0 to 123) + KSS(0 to 431) (see note 1)
TCH/S (full)	274	KSS(0 to 273)
STCH+TCH/S	124 + 137	KSS(0 to 123) + KSS(216 to 352)
SCH/F	268	KSS(0 to 267)
SCH/HU (see note 2)	92	KSS(0 to 91)
SCH/HD+SCH/HD	124 + 124	KSS(0 to 123) + KSS(216 to 339)
STCH+STCH	124 + 124	KSS(0 to 123) + KSS(216 to 339)
BSCH+SCH/HD	60 + 124	clear +KSS(216 to 339)
SCH/HD+BNCH	124 + 124	KSS(0 to 123) + clear
SCH-P8/HU (see note 2)	148	KSS(0 to 147)
SCH-P8/HD+SCH-P8/HD	196+196	KSS(0 to 195) + KSS(216 to 411)
SCH-P8/F	412	KSS(0 to 411)
SCH-Q/RA (first half slot)	65	KSS(0 to 64)
SCH-Q/RA (second half slot)	65	KSS(65 to 129)
SCH-Q/HU25 (see note 2)	440	KSS(0 to 439)
SCH-Q/HU50 (see note 2)	944	KSS(0 to 943)
SCH-Q/HU100 (see note 2)	1 952	KSS(0 to 1 951)
SCH-Q/HU150 (see note 2)	2 960	KSS(0 to 2 959)
SCH-Q/U25	1 184	KSS(0 to 1 183)
SCH-Q/U50	2 432	KSS(0 to 2 431)
SCH-Q/U100	4 928	KSS(0 to 4 927)
SCH-Q/U150	7 424	KSS(0 to 7 423)
SCH-Q/D25	1 208	KSS(0 to 1 207)
SCH-Q/D50	2 624	KSS(0 to 2 623)
SCH-Q/D100	5 456	KSS(0 to 5 455)
SCH-Q/D150	8 288	KSS(0 to 8 287)

NOTE 1: Where TCH/7.2 is stolen the first 216 encrypted bits of TCH/7.2 are not transmitted.
NOTE 2: The same KSS allocation applies whether the first or second half slot is selected for transmission.

NOTE 1: KSS repeat is possible only for multi-slot interleaved circuit mode data when both half slots in a single slot are stolen.

NOTE 2: The AACH, BSCH, BNCH, SICH-Q/U, SICH-Q/D, AACH-Q/D and BNCH-Q/D logical channels are not encrypted.

NOTE 3: The numbers of bits and the KSS allocations indicated in table 13 for QAM channels are those required for uncoded logical channels using 64-QAM (except for SCH-Q/RA which always uses 4-QAM). EN 300 392-2 [2] clause 23.2.1 lists the sizes of all SCH-Q logical channels. The starting points indicated in table 13 for the KSS allocations apply to uncoded and coded logical channels. Coded logical channels require fewer KSS bits than uncoded logical channels. Also, 4-QAM and 16-QAM logical channels require fewer KSS bits than 64-QAM logical channels using the same coding rate.

6.4.2 Allocation of KSS to logical channels with PDU association

6.4.2.1 General

On the control channel, the MAC may perform PDU association, where more than one PDU may be transmitted within one slot. These PDUs may be addressed to different identities and may use different cipher keys. The MAC headers themselves may be of varying lengths.

6.4.2.2 KSS allocation on phase modulation channels

On phase modulation channels the KSS shall be restarted at the commencement of each SDU (see figures 48, 49 and 50).

This mechanism shall apply in all control channel cases, including in the case of half slots on downlink or uplink.

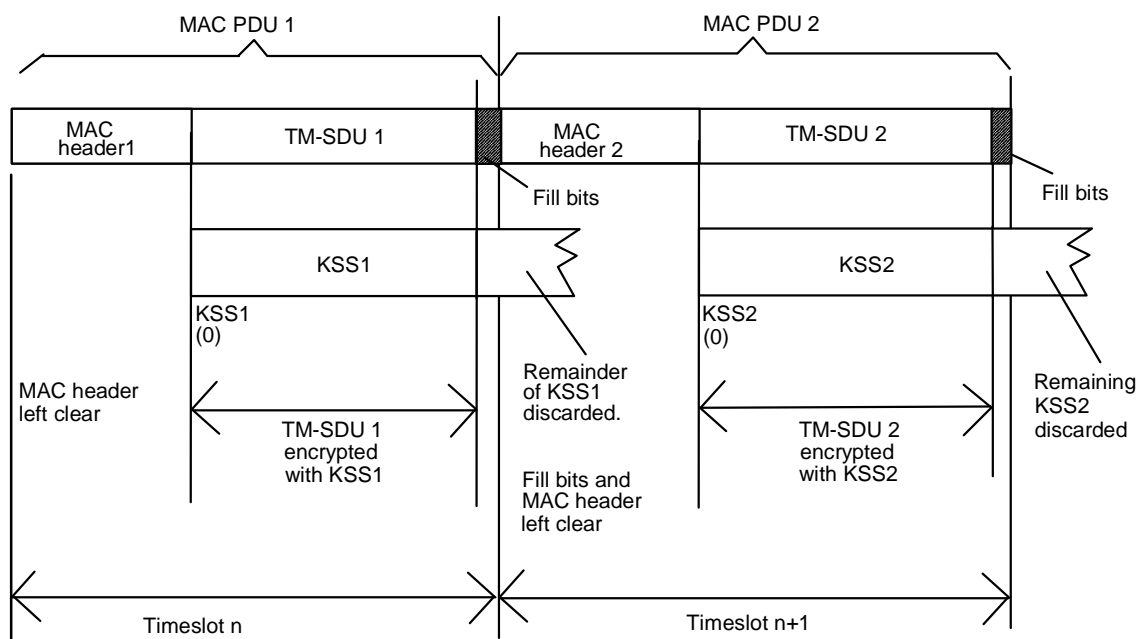
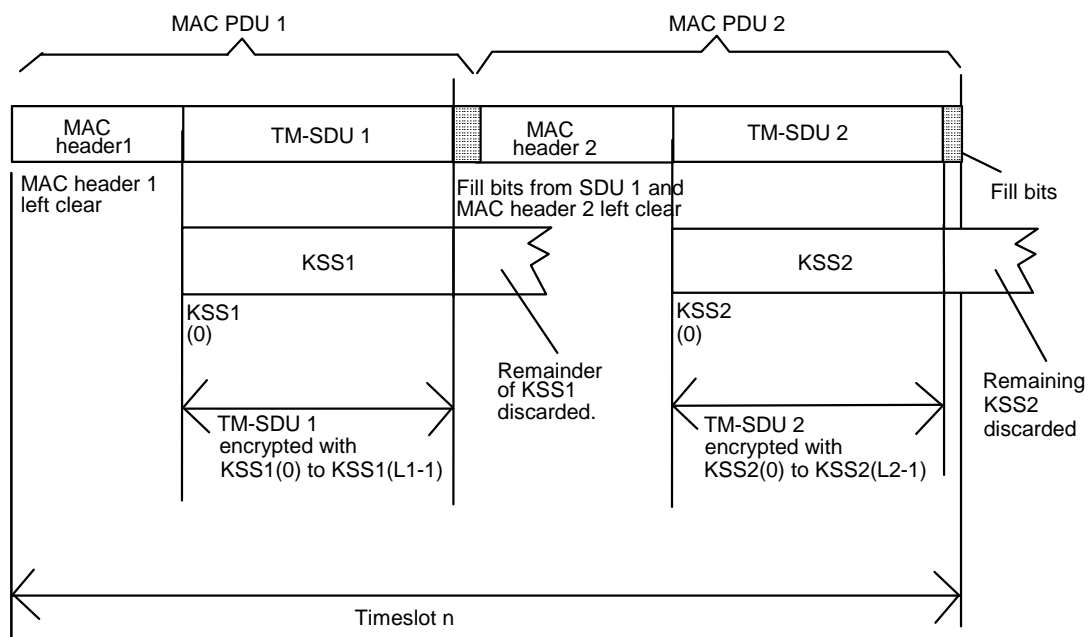
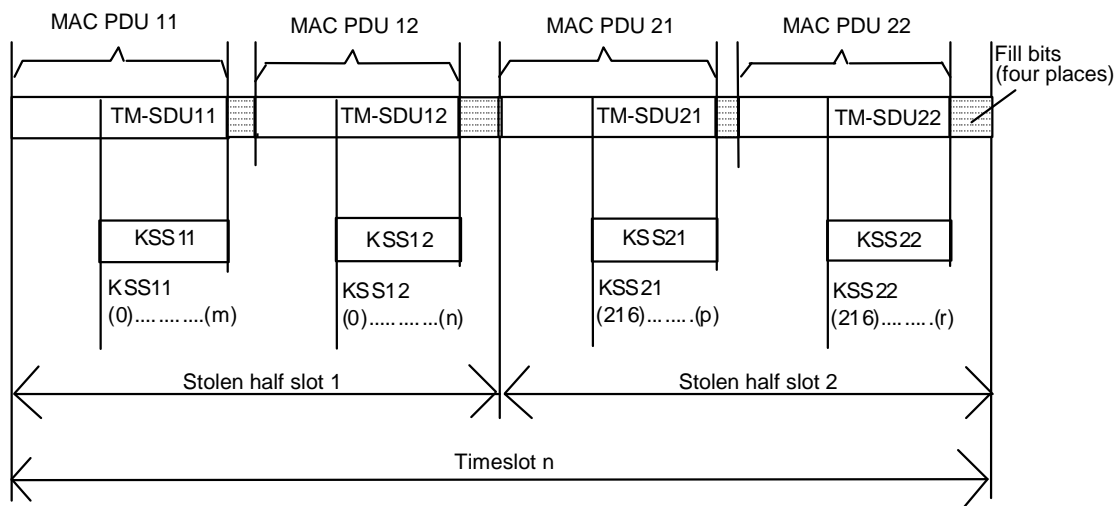

Figure 48: Allocation of KSS to encrypt MAC PDUs



NOTE: Length of TM-SDU 1 is L1, length of TM-SDU 2 is L2.

Figure 49: Allocation of KSS to encrypt MAC PDUs with PDU Association for full slot logical channels



NOTE 1: KSS11(m+1) onwards discarded.

NOTE 2: KSS12(n+1) onwards discarded.

NOTE 3: KSS21(0) to KSS21(215) and KSS21(p+1) onwards discarded.

NOTE 4: KSS21(0) to KSS21(215) and KSS21(r+1) onwards discarded.

Figure 50: Allocation of KSS to encrypt MAC PDUs with PDU Association for half slot logical channels

To avoid replay of key stream, the following should be avoided where PDU association takes place:

- sending more than one SDU encrypted with the same encryption key within one logical channel.

NOTE: For the sake of clarity figures 49 and 50 show only two MAC PDUs being associated within a full or half slot, but there may be more if the MAC PDUs are sufficiently small.

6.4.2.3 KSS allocation on QAM channels

On QAM channels two different KSS allocation schemes exist. The fixed-mapping KSS allocation scheme applies to all class 2 encryption (using the SCK), to class 3 encryption using the CCK and to class 3 encryption using a GCK. The offset-mapping KSS allocation scheme applies to all class 3 encryption using a DCK.

6.4.2.3.1 Fixed mapping

This method of allocating KSS to QAM channels shall apply to all encryption using an SCK, a CCK or a GCK. Each fixed-mapped KSS used in a logical channel shall be mapped so that a defined starting bit from the KSS corresponds to the first bit of the timeslot or subslot (e.g. KSS(0) or KSS(65) may be mapped to the first bit of the first MAC header), and successive KSS bits shall be mapped to successive bits of the logical channel, encrypted or not. Where a PDU bit does not require encryption, the corresponding KSS bit shall be discarded. Where a PDU bit does require encryption, the corresponding KSS bit shall be XORed with the PDU bit. Where different PDUs use different cipher keys, the KSS for each different cipher key shall be mapped to the logical channel in the same way. This is illustrated in figures 50a and 50b (figure 50b shows three MAC PDUs being associated within a timeslot, but there may be more, depending on the sizes of the PDUs and the capacity of the timeslot). The starting bit numbers for the mapping to each type of QAM logical channel are defined in table 13.

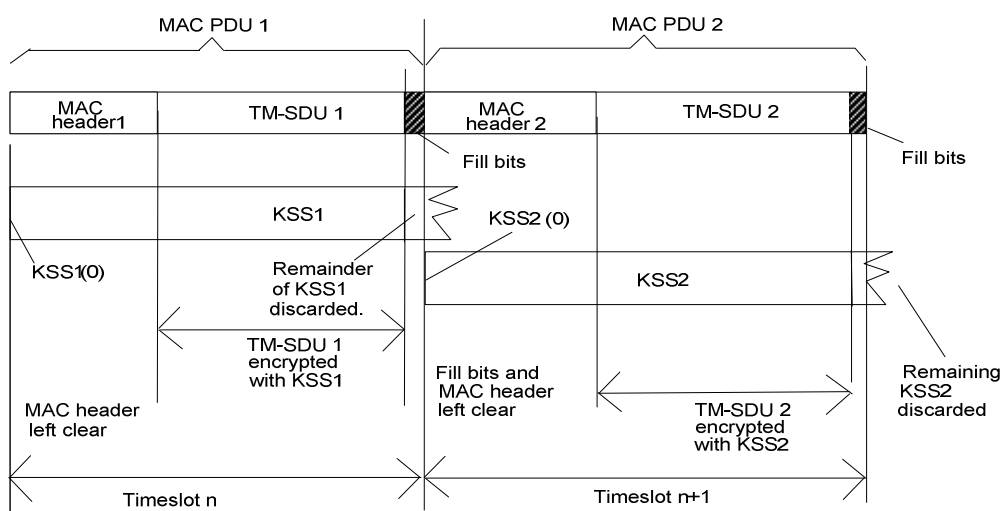
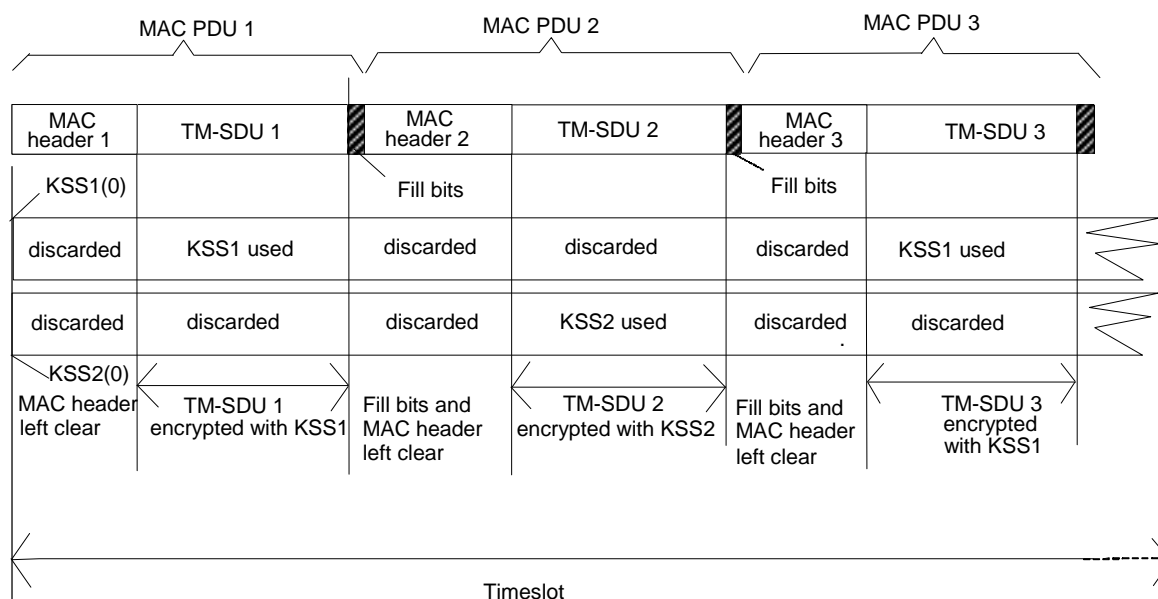

Figure 50a: Fixed-mapped allocation of KSS to encrypt QAM MAC PDUs



NOTE: In this example, TM-SDU 1 and TM-SDU 3 use the same cipher key but TM-SDU 2 uses a different cipher key.

Figure 50b: Fixed-mapped allocation of KSS to encrypt QAM MAC PDUs with PDU association for full slot logical channels

6.4.2.3.2 Offset mapping

This method of allocating KSS to QAM channels shall apply to all encryption using a DCK. Each offset-mapped KSS used in a logical channel shall be mapped so that a defined starting bit from the KSS corresponds to the first bit of the first MAC-PDU to be encrypted with that KSS (e.g. KSS(0) or KSS(65) may be mapped to the first bit of the first MAC header), and successive KSS bits shall be mapped to successive bits of PDUs encrypted using the same DCK in the current timeslot or subslot.

Where a PDU bit does not require encryption, the corresponding KSS bit shall be discarded. Where a PDU bit does require encryption, the corresponding KSS bit shall be XORed with the PDU bit. Where further PDUs using the same DCK (i.e. using the same address) are associated in the same timeslot or subslot, the KSS shall be temporarily suspended following the last bit of the previous PDU (including any fill bits) encrypted with the same DCK but continued from the first bit of the next PDU encrypted with the same DCK. Where associated PDUs use different DCKs (i.e. using different addresses), the KSS for each different DCK shall be mapped to the logical channel in the same way (starting from the first bit of the first MAC header using that address). This is illustrated in figure 50c (figure 50c shows three MAC PDUs being associated within a timeslot, but there may be more, depending on the sizes of the PDUs and the capacity of the timeslot).

Fill bits shall not be encrypted.

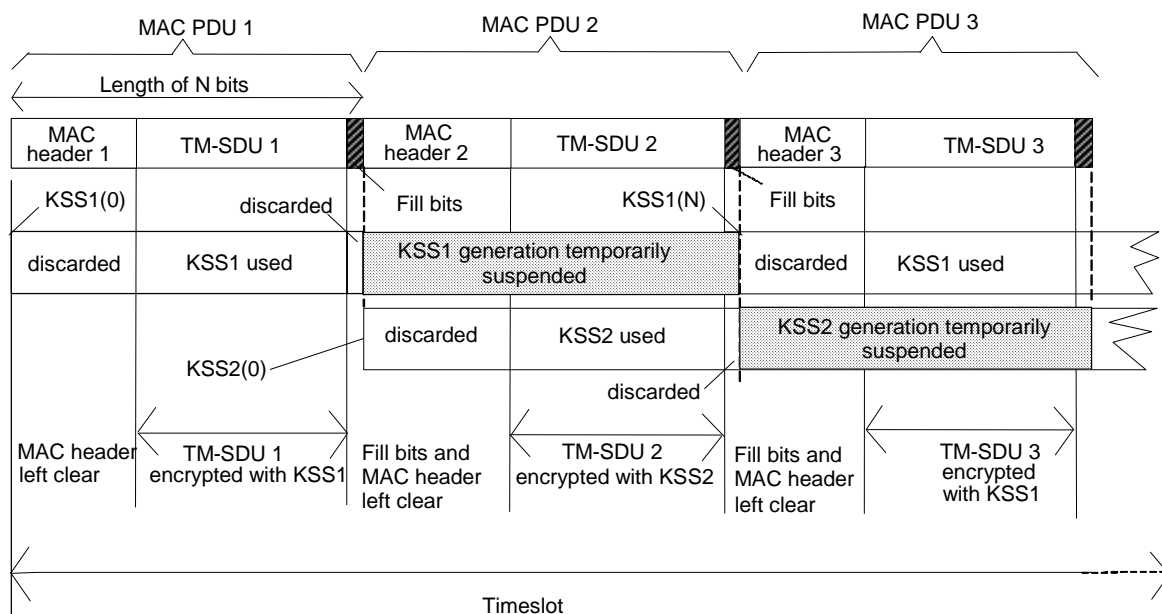

NOTE: In this example, TM-SDU 1 and TM-SDU 3 use the same DCK but TM-SDU 2 uses a different DCK.

Figure 50c: Offset-mapped allocation of DCK-derived KSS to encrypt QAM MAC PDUs with PDU association for full slot logical channels

6.4.3 Synchronization of data calls where data is multi-slot interleaved

NOTE: The examples below assume that the data call is a single slot call transmitted on timeslot 1 of each frame.

In multi-slot interleaved calls the original traffic burst is expanded to cover 4 or 8 bursts (TCH/2.4, TCH/4.8). The interleaving follows encryption at the transmitter, and decryption follows de-interleaving at the receiver.

Transmitted Traffic	T1	T2	T3	T4	T5	T6	T7	T8
Transmitted Frame	FN1	FN2	FN3	FN4	FN5	FN6	FN7	FN8
Encryption IV value	IVStart+1	IVStart+5	IVStart+9	IVStart+13	IVStart+17	IVStart+21	IVStart+25	IVStart+29
Interleaving over 4 frames	T1 (1 of 4)	T1(2 of 4)	T1 (3 of 4)	T1 (4 of 4)	T5 (1 of 4)	T5 (2 of 4)	T5 (3 of 4)	T5 (4 of 4)
	null	T2 (1 of 4)	T2 (2 of 4)	T2 (3 of 4)	T2 (4 of 4)	T6 (1 of 4)	T6 (2 of 4)	T6 (3 of 4)
	null	null	T3 (1 of 4)	T3 (2 of 4)	T3 (3 of 4)	T3 (4 of 4)	T7 (1 of 4)	T7 (2 of 4)
	null	null	null	T4 (1 of 4)	T4 (2 of 4)	T4 (3 of 4)	T4 (4 of 4)	T8 (1 of 4)
Recovered traffic frame	T1	T2	T3	T4	T5			
Decryption IV value	IVStart+1	IVStart+5	IVStart+9	IVStart+13	IVStart+17			
Actual IV value	IVStart+13	IVStart+17	IVStart+21	IVStart+25	IVStart+29			

NOTE 1: IV_{Start} is the value of IV used in the synchronization bursts.

NOTE 2: Actual IV value is to be used for decryption of non-traffic bursts.

Figure 51: Value of IV to be used for TCH/4.8 or TCH/2.4 with interleaving depth of 4

The actual IV value is to be used by the receiver for the synchronization bursts and any bursts that are not (interleaved) traffic. The value of IV to be used in the receiver shall be " $IV_A - 4 \times (\text{interleaving depth} - 1)$ ", where IV_A is the actual value of IV.

Transmission across frame 18 shall be treated as shown in figure 52.

Transmitted Traffic	T15	T16	T17	Synch.	T18	T19	T20	T21
Transmitted Frame	FN15	FN16	FN17	FN18	FN1	FN2	FN3	FN4
Encryption IV value	IVStart	IVStart+4	IVStart+8	IVStart+12	IVStart+16	IVStart+20	IVStart+24	IVStart+28
Interleaving over 4 frames	T15 (1 of 4)	T15 (2 of 4)	T15 (3 of 4)		T15 (4 of 4)	T19 (1 of 4)	T19 (2 of 4)	T19 (3 of 4)
	T12 (4 of 4)	T16 (1 of 4)	T16 (2 of 4)		T16 (3 of 4)	T16 (4 of 4)	T20 (1 of 4)	T20 (2 of 4)
	T13 (3 of 4)	T13 (4 of 4)	T17 (1 of 4)		T17 (2 of 4)	T17 (3 of 4)	T17 (4 of 4)	T21 (1 of 4)
	T14 (2 of 4)	T14 (3 of 4)	T14 (4 of 4)		T18 (1 of 4)	T18 (2 of 4)	T18 (3 of 4)	T18 (4 of 4)
Recovered traffic frame	T12	T13	T14	Synch.	T15	T16	T17	T18
Decryption IV value				IVStart+12	IVStart	IVStart+4	IVStart+8	IVStart+16
Actual IV value	IVStart	IVStart+4	IVStart+8	IVStart+12	IVStart+16	IVStart+20	IVStart+24	IVStart+28

NOTE: IV_{Start} is the value of IV used in the first traffic frame in this example.

Figure 52: Treatment of IV for TCH/4.8 or TCH/2.4 with interleaving depth of 4 at frame 18

For traffic frames starting, but not fully received, before frame 18, the value of IV to be used for encryption shall be " $IV_A - 4 \times (\text{interleaving depth} - 1) - 4$ ", where IV_A is the actual value of IV.

6.4.4 Recovery of stolen frames from interleaved data

If the stolen frame has been stolen from the C-PLANE it shall not be treated as if it were interleaved and shall therefore be decrypted with the "actual" value of IV for immediate delivery to the C-PLANE.

If the stolen frame has been stolen from circuit mode data in the U-PLANE it shall be treated as interleaved and shall follow the same rules as for data traffic.

6.5 Use of cipher keys

The cipher keys and their allocation are described in clauses 4.2.1 to 4.2.4.

The header of MAC PDUs transmitted over the air interface shall contain indication whether the MAC PDU and some elements of the MAC Header (SSI address and channel allocation elements) are encrypted or not. In addition the header of MAC downlink PDUs includes one bit that shall indicate the least significant bit of the version of CCK or SCK that is in use. This indication is used to assist the MS to detect if the CCK or SCK has been changed if the D-CK CHANGE DEMAND PDU has been missed. It can only provide this assistance when the least significant bits of the old and new keys are different.

In cells of security class 2 the SCK shall be used to encrypt individual addressed signalling and traffic. SCK shall also be used with the identity encryption mechanism to conceal identities in use at the air interface within a SwMI. Only one SCK shall be in use within a SwMI at any one time except during key change period.

In cells of security class 3 the DCK shall be used to encrypt all signalling and traffic sent from an MS to the SwMI, and to encrypt individually addressed signalling and traffic sent from the SwMI to the MS.

In cells of security class 3 that support group calls a GCK may be associated with a single or multiple group addresses at any time. The CCK shall be used as a key modifier to produce the MGCK, which shall be used to encrypt group addressed signalling and traffic (see clause 4.2.2). If no GCK is assigned to a group then CCK shall be used to encrypt all group addressed signalling and traffic. CCK shall also be used in conjunction with the identity encryption mechanism to protect all SSIs used with encryption within an LA. An MS may store the CCKs in use in more than one LA to ease cell re-selection.

The use of cipher keys for security class 3 is illustrated in figure 53.

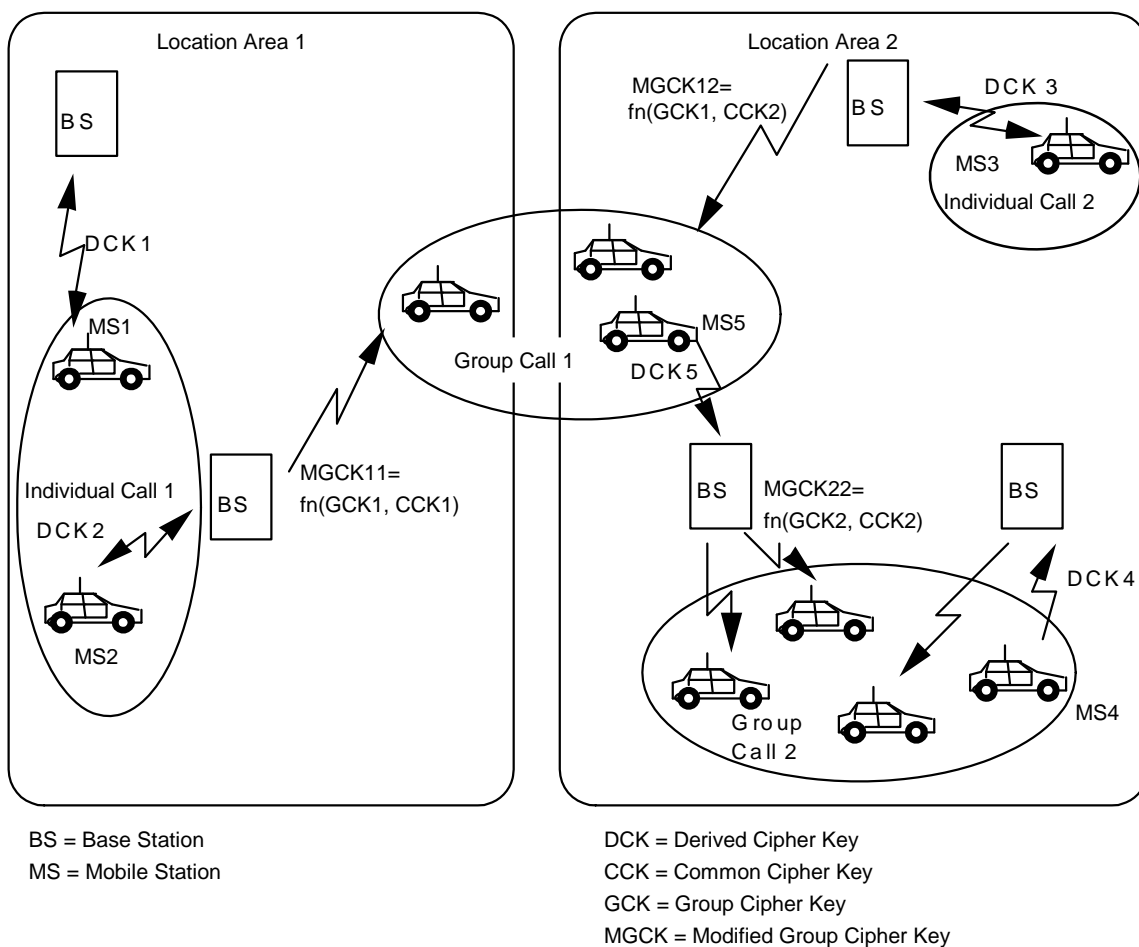

Figure 53: Illustration of cipher key use in class 3 system

6.5.1 Identification of encryption state of downlink MAC PDUs

The encryption mode element (two bits) in the header of the downlink MAC-RESOURCE PDU shall be used for air interface encryption management and shall indicate the encryption state of each TM-SDU for each cell security class as shown in clauses 6.5.1.1 to 6.5.1.3. These bits also indicate the use of the ESI mechanism.

6.5.1.1 Class 1 cells

In a cell supporting only class 1 only the values and interpretations given in table 14 shall apply.

Table 14: Encryption mode element in class 1 cell contents

Information element	Length	Value	Remark
Encryption mode element	2	00 ₂	PDU not encrypted
		Others	Reserved

6.5.1.2 Class 2 cells

In a class 2 cell only the values and interpretations given in table 15 shall apply.

Table 15: Encryption mode element in class 2 cell contents

Information element	Length	Value	Remark
Encryption mode element	2	00 ₂	PDU not encrypted
		01 ₂	Reserved
		10 ₂	PDU encrypted, SCK-VN is even
		11 ₂	PDU encrypted, SCK-VN is odd

To prevent attacking by replaying a previous key, the SCK shall be identified by a longer SCK-VN which shall be sent to an MS together with the SCK.

NOTE: During a key changeover there may be a period when keys are different on different cells.

6.5.1.3 Class 3 cells

In a class 3 cell the following values and interpretations shall apply.

Table 16: Encryption mode element in class 3 cell contents

Information element	Length	Value	Remark
Encryption mode element	2	00 ₂	PDU not encrypted
		01 ₂	Reserved
		10 ₂	PDU encrypted, CCK-id is even
		11 ₂	PDU encrypted, CCK-id is odd

In class 3 cells every cell in an LA shall use the same CCK and it shall be identified by a common CCK-id in all the cells of the LA. The SwMI may also provide a CCK that it is applicable in more than one LA. If so the CCK shall be identified by a common CCK-id in all these applicable Las. CCK change shall therefore be synchronized across all cells in an LA, and across all Las in which SwMI tells that the same CCK is applicable. The CCK shall be identified by a longer CCK-id which shall be sent to an MS together with the CCK. The CCK-id can be selected independently for each location area by the SwMI. When a PDU is encrypted, the least significant bit of the encryption mode element in the MAC header shall be equal to the least significant bit of the CCK-id for the CCK in use.

NOTE 1: During a key changeover there may be a period when keys are different on different cells of applicable Las.

NOTE 2: When CCK is changed the SwMI has to ensure that the MS can recognize a CCK change in the encryption mode element.

6.5.2 Identification of encryption state of uplink MAC PDUs

One bit of uplink signalling MAC PDU headers shall be reserved for air interface encryption. This shall indicate whether the contents of the PDU are encrypted or not.

This bit shall take one of the following values:

- 0 = Encryption off;
- 1 = Encryption on.

If it is desired to change the DCK in use by an MS, this shall be achieved by the authentication process; and as both BS and MS are involved in the process and have knowledge that it has occurred, it shall not be necessary to include a key identifier in the uplink header.

The encryption mode element shall also indicate the use of the encrypted short identity mechanism described in clause 4.2.6 for cells of class 2 and class 3.

6.6 Mobility procedures

6.6.1 General requirements

The cell selection procedures are defined in EN 300 392-2 [2], clause 18.3.4 and shall always apply with the additional security criteria defined below:

- 1) if the MS does not support the security class of the cell it shall not select the cell;
- 2) if the MS does not support authentication as required by the cell it shall not select the cell;
- 3) if moving to a new cell of different class from the current serving cell the MS may have to perform the location update procedure at the new cell.

In moving from a cell of security class 3 or security class 2 to a cell of security class 1 the SwMI shall determine if the call can be restored. The SwMI may wish to deny call restoration in this case because the air interface security has been changed.

6.6.1.1 Additional requirements for class 3 systems

Where scanning of adjacent cells is performed by the moving MS the MS shall gain knowledge of the CCK-id of the CCK in use on the adjacent cell by receiving the SYSINFO broadcast, and of the value of IV on that cell by receiving the SYNC and SYSINFO broadcasts. The broadcast parameters shall be made available to the MM sub-layer by MLE using the MLE-INFO indication primitive.

Within an LA of security class 3 all cells shall have knowledge of the DCK in use for each ITSI operating in that LA. If the SwMI offers a registered area to the MS it shall ensure that all LAs have knowledge of the DCK for that MS operating in that registered area.

6.6.2 Protocol description

If the SwMI supports GCK operation the SwMI shall indicate this using the "GCK Supported" field, described in clause A.8.29a, in the Extended Service Broadcast information element, described in EN 300 392-2 [2]. This field shall be used to indicate to the MS when GCKs are in use or not in use by the cell.

6.6.2.1 Negotiation of cipher parameters

Encryption mode control is achieved by an exchange of MM PDUs at registration. The PDU exchange shall allow switching both from clear to encrypted mode and the reverse.

An MS may indicate its current encryption state to its user.

Every registration shall include cipher parameter negotiation to allow the MS to establish the security parameters advised in the cell broadcast.

EN 300 392-2 [2] defines the presence of cipher parameters in the D-LOCATION UPDATE COMMAND, D-LOCATION UPDATE REJECT and U-LOCATION UPDATE DEMAND PDUs. The use of these parameters is described in this part of the EN.

The ciphering parameters shall be used to negotiate SCKN and KSG in class 2 cells, and KSG in class 3 cells using the cipher parameters element defined in table A.46.

Table 17: Void

If a cell supports class 2 and class 1, or class 3 and class 1, negotiation of cipher parameters by the MS shall be at the highest security class possible for the MS.

NOTE: When registering for SC3 operation, the Cipher Parameters element is also used by the MS to indicate its support for TM-SCK OTAR, SDMO and DM-SCK OTAR, and GCK encryption/OTAR (see clause 6.2.0.2).

6.6.2.1.1 Class 1 cells

Cipher control shall always be set to false and the ciphering parameters shall not be provided.

6.6.2.1.2 Class 2 cells

Cipher control shall always be set to true and the ciphering parameters shall be provided.

On registration the MS shall declare its preferred KSG and SCKN (broadcast by the cell) to the SwMI. If these parameters are accepted by the SwMI the registration shall continue as described in EN 300 392-2 [2], clause 16. If the parameters are unacceptable the SwMI shall reject the registration and shall indicate the preferred parameters in the D-LOCATION UPDATE REJECT PDU.

6.6.2.1.3 Class 3 cells

Cipher control shall always be set to true and the ciphering parameters shall be provided.

On registration the MS shall declare its preferred KSG to the SwMI. If these parameters are accepted by the SwMI the registration shall continue as described in EN 300 392-2 [2], clause 16. If the parameters are unacceptable the SwMI shall reject the registration and shall indicate the preferred parameters in the D-LOCATION UPDATE REJECT PDU.

6.6.2.2 Initial and undeclared cell re-selection

See also EN 300 392-2 [2], clause 18.3.4.7.2.

In cells of security class 2 the MS may, if required, register and authenticate to the new cell.

In cells of security class 3 the MS may register and authenticate to the new cell and in so doing receive new values of DCK and CCK. If when camped on the cell the MS confirms that it holds a valid CCK for the cell (from capturing the CCK-id in SYSINFO) it may not refresh the CCK during registration.

NOTE: The broadcast parameters are available to MM from the MLE-INFO indication primitive.

For initial cell selection (power on) in the home network, the MS may only apply AI encryption if the SwMI indicates it supports "DCK retrieval during initial cell selection" (DCK retrieval), shown in table A.104, and the MS possesses a valid DCK and a valid CCK for the LA of the cell. A valid DCK is defined as the DCK that was last derived between the MS and the home SwMI.

For initial cell selection (power on) in a visited network, the MS shall assume that the DCK generated in the previous network is no longer valid. Therefore, the MS shall not apply AI encryption independent of the indication by the SwMI to support "DCK retrieval during initial cell selection" (DCK retrieval), shown in table A.104.

When the MS has successfully invoked initial cell selection with the SwMI but suffers momentary radio link failure, the MS may use "roaming location updating" when the radio link is re-established, in which case the MS may only apply AI encryption if the SwMI indicates it supports "DCK retrieval during cell re-selection" (DCK retrieval), shown in table A.104, and the MS possesses a valid DCK and a valid CCK for the LA of the cell. A valid DCK is defined as the DCK that was last derived between the MS and the SwMI.

When the SwMI supports DCK retrieval during cell re-selection, if it possesses a valid CCK for the LA of the new cell the MS shall not use U-OTAR PREPARE and may apply AI encryption to location update signalling on the new cell.

When the SwMI supports DCK retrieval during cell re-selection and the MS does not possess a valid CCK for the LA of the new cell, the MS shall request the CCK of the new cell using U-OTAR PREPARE before selection of the new cell, and may apply AI encryption to location update signalling on the new cell.

If the SwMI does not support DCK retrieval during cell re-selection, and if the MS knows the preferred neighbour cell, the MS may use the U-OTAR PREPARE PDU indicating the LA of the new cell where the PDU is sent on the MCCH and shall start timer T372. On receipt of U-OTAR PREPARE, the SwMI shall forward the DCK belonging to the MS to the cells belonging to the LA (DCK forwarding), if possible. The MS shall reset timer T372 on receipt of D-OTAR NEWCELL. Following this, the MS may apply AI encryption to location update signalling on the new cell if the DCK forwarding was successful and it possesses a valid CCK for the LA of the new cell. This procedure is shown in figure 54 where the LA-id of the new cell is known to the MS. The MS may request the CCK of the new cell using U-OTAR PREPARE if it does not already have it.

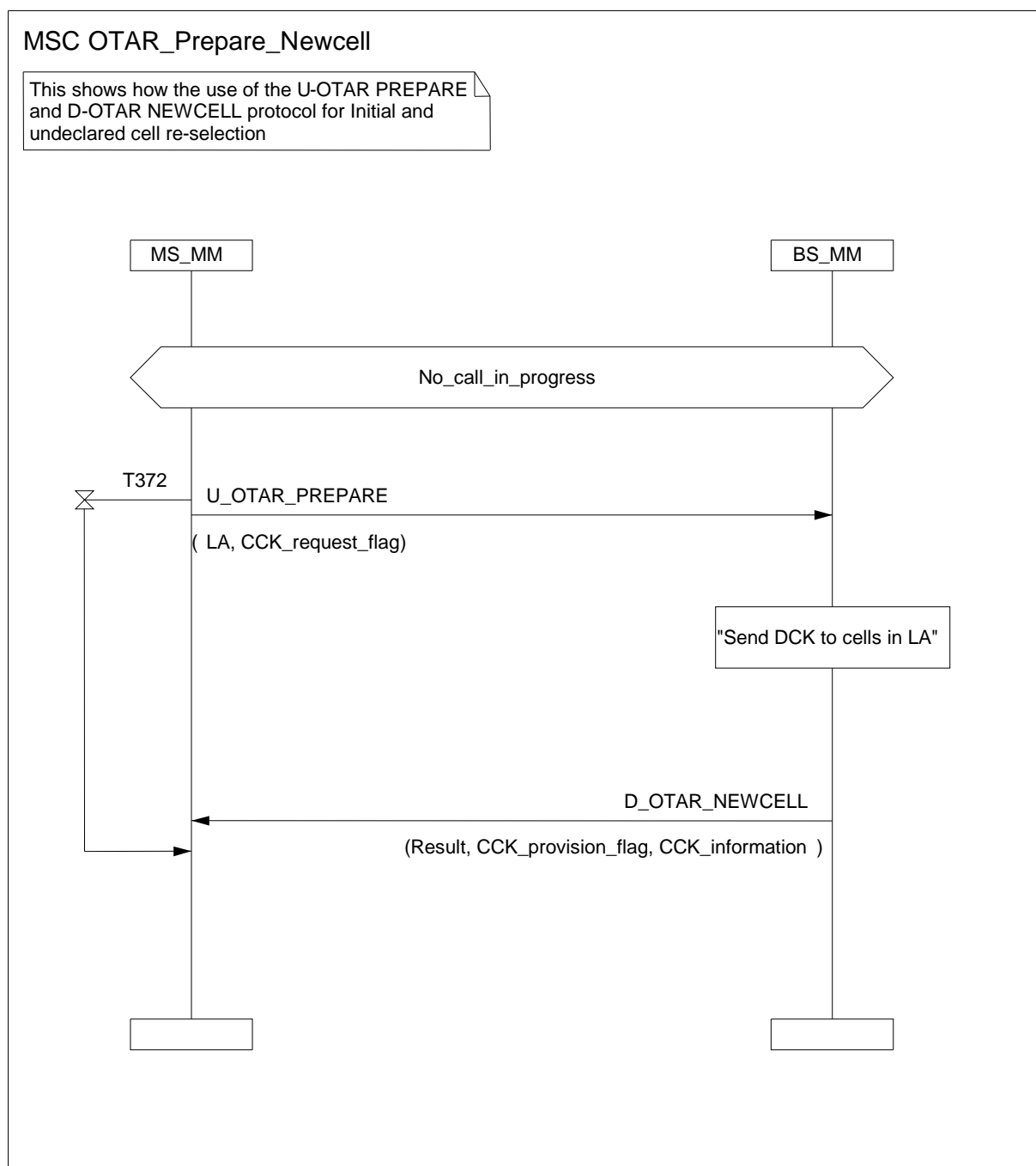

Figure 54: Use of U-OTAR PREPARE and D-OTAR NEWCELL protocol

If the MS does not know a preferred neighbour cell, it cannot indicate the preferred neighbour cell to the SwMI and therefore the SwMI cannot forward the DCK to the new cell. On successful completion of cell re-selection, and if forwarding of the DCK failed or was not possible (due to radio link failure), the MS may only apply AI encryption to location updating if the SwMI indicates it supports "DCK retrieval during cell re-selection" (referred to herein as DCK retrieval), shown in table A.104, and the MS possesses a valid CCK for the LA of the new cell.

6.6.2.3 Unannounced cell re-selection

See also EN 300 392-2 [2], clause 18.3.4.7.3.

In cells of security class 2 the MS may register and if required authenticate to the new cell.

After successful registration and restoration of security parameters any calls in progress may be restored.

In cells of security class 3 the MS may register and authenticate to the new cell and in so doing receive new values of DCK and CCK.

When the SwMI supports DCK retrieval during cell re-selection, the MS shall not use U-OTAR PREPARE and may apply AI encryption to location update signalling on the new cell if it possesses a valid CCK for the LA of the new cell. However, if the SwMI does not support DCK retrieval during cell re-selection, and if the MS knows the preferred neighbour cell it should indicate the LA of the new cell using the U-OTAR PREPARE PDU sent on the MCCH and shall start timer T372. When the SwMI receives this signalling it shall forward the DCK belonging to the MS to the cells belonging to the LA (DCK forwarding) if possible. The MS shall reset timer T372 on receipt of D-OTAR NEWCELL. Following this, the MS may apply AI encryption to location update signalling on the new cell if the DCK forwarding was successful and it possesses a valid CCK for the LA of the new cell.

If the MS does not know a preferred neighbour cell it cannot indicate the preferred neighbour cell to the SwMI and therefore the SwMI cannot forward the DCK to the new cell. On successful completion of cell re-selection, the MS may only apply AI encryption if the SwMI indicates it supports "DCK retrieval during cell re-selection" (DCK retrieval), shown in table A.104, and the MS possesses a valid CCK for the LA of the new cell.

6.6.2.4 Announced cell re-selection type-3

See also EN 300 392-2 [2], clause 18.3.4.7.4.

When the SwMI supports DCK retrieval during cell re-selection, the MS shall not use U-OTAR PREPARE and may apply AI encryption to location update signalling on the new cell if it possesses a valid CCK for the LA of the new cell. However, if the SwMI does not support DCK retrieval during cell re-selection, and if the MS knows the preferred neighbour cell it should indicate the LA of the new cell using the U-OTAR PREPARE PDU and shall start timer T372. When the SwMI receives this signalling it shall forward the DCK belonging to the MS to the cells belonging to the LA (DCK forwarding) if possible. The MS shall reset timer T372 on receipt of D-OTAR NEWCELL. Following this, the MS may apply AI encryption to location update signalling on the new cell if the DCK forwarding was successful and it possesses a valid CCK for the LA of the new cell.

6.6.2.5 Announced cell re-selection type-2

See also EN 300 392-2 [2], clause 18.3.4.7.5.

The SwMI shall use the cell identifier in the U-PREPARE to forward the DCK to the new cell (DCK forwarding). On successful completion of cell re-selection, the MS may apply AI encryption on the new cell if it possesses a valid CCK for the location area of the new cell. If the MS does not possess a valid CCK for the new cell it should request it before selection of the new cell.

6.6.2.6 Announced cell re-selection type-1

See also EN 300 392-2 [2], clause 18.3.4.7.6.

The SwMI shall use the cell identifier in the U-PREPARE to forward the DCK to the new cell (DCK forwarding). On successful completion of cell re-selection, the MS may apply AI encryption on the new cell if it possesses a valid CCK for the location area of the new cell. If the MS does not possess a valid CCK for the new cell it shall request it before selection of the new cell.

6.6.2.7 Key forwarding

When the SwMI does not support DCK retrieval during cell re-selection, the U-OTAR PREPARE / D-OTAR NEWCELL signalling is used for forwarding the DCK to the new LA and requesting the associated CCK. No other mobility management or call restoration functionality shall be assumed by the SwMI or the MS.

Timer T372, Key Forwarding Timer, shall have a value of 5 seconds.

T372 shall indicate the maximum time the MM shall wait for a response to U-OTAR PREPARE. If timer T372 expires, or radio link failure occurs, the MS shall abandon signalling and initiate the cell change procedure immediately (see figure 55).

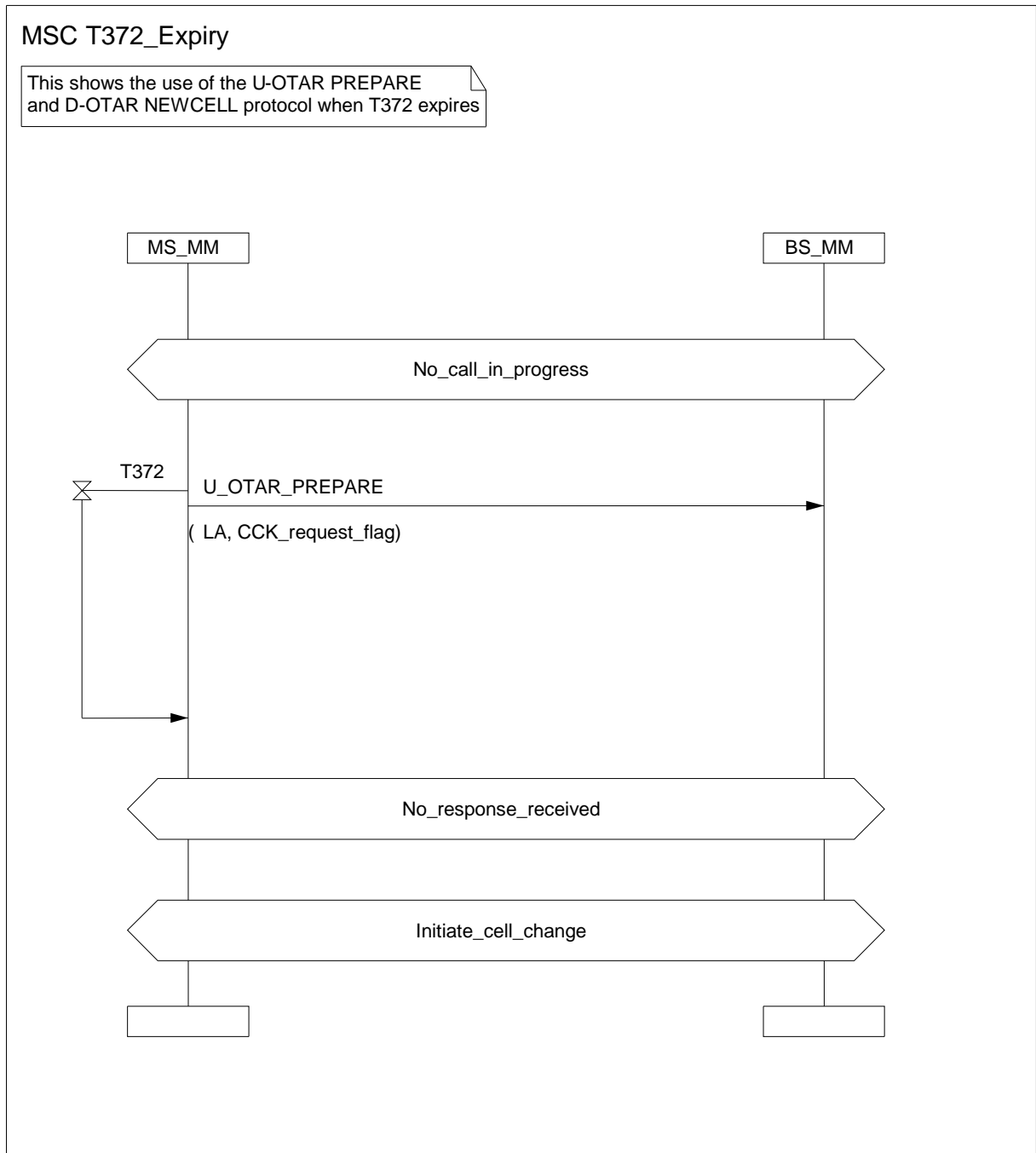

Figure 55: Use of U-OTAR PREPARE and D-OTAR NEWCELL protocol with T372 expiry

6.7 Encryption control

The following clauses apply for class 2 and class 3 cells.

6.7.1 Data to be encrypted

6.7.1.1 Downlink control channel requirements

The following control messages shall not be encrypted on the downlink, as they may be used by MSs prior to establishment of encryption parameters:

- cell synchronization messages sent to the MAC via the TMB-SAP (SYNC, SYSINFO); and
- the ACCESS DEFINE PDU is not encrypted as it has no associated TM-SDU.

6.7.1.2 Encryption of MAC header elements

When encryption is enabled some of the MAC header shall be considered by the encryption unit as belonging to the TM-SDU. The following rules apply when the encryption is on:

- in the MAC-RESOURCE PDU (see EN 300 392-2 [2], clause 21.4.3.1) all information following the channel allocation flag shall be encrypted. The channel allocation flag shall not be included in the data to be encrypted;
- in the downlink MAC-END PDU (see EN 300 392-2 [2], clause 21.4.3.3) all information following the channel allocation flag shall be encrypted. The channel allocation flag shall not be included in the data to be encrypted.

The encryption process shall be accomplished in the same manner as is used to encrypt TM-SDUs, i.e. the modulo 2 addition of a key stream, where the key stream shall be generated as a function of frame numbering and cipher key relevant to the addressed party or parties.

The KSG shall be initialized as described in clause 6.3.2.1.

6.7.1.3 Traffic channel encryption control

Traffic channels may be transporting speech or data. The information shall be encrypted prior to channel encoding.

Traffic slots do not incorporate a separate MAC header in the same way as control (signalling) slots. Instead, the entire slot is used for traffic data. Therefore on a traffic slot, the SDU that is encrypted is the entire content of the transmitted slot.

The initial use of encryption on the U-PLANE shall maintain the use of encryption of the C-PLANE signalling message which contains the channel allocation element.

The MAC-RESOURCE PDU indicates the encryption state of the PDU and when the PDU contains a channel allocation element the encryption state of the assigned channel shall follow the state of MAC RESOURCE PDU (see EN 300 392-2 [2], clause 21.4.3.1) and the "Encryption mode element" as defined in clause 6.5.1. Encryption of control and traffic (speech/data) channels shall be switched on and off only by the SwMI. For the duration of the channel allocation the encryption state shall not change, however change of parameters within the encryption state may be allowed.

In the case that U-PLANE mode is "encrypted" the MS shall send all signalling encrypted (sent with one of stealing, Fast Associated Control Channel (FACCH), Slow Associated Control Channel (SACCH)). In the case where U-PLANE mode of an assigned channel for a call is "clear" the MS shall send all signalling related to that call in clear (sent with one of stealing, FACCH, SACCH) and other signalling may be encrypted.

U-PLANE signalling (using STCH) is encrypted starting from the first bit of TM-SDU (see EN 300 392-2 [2], clause 21.4.5). In this case the MAC header does not contain the encryption flag, hence encryption parameters shall be the same as for the traffic.

6.7.1.4 Handling of PDUs that do not conform to negotiated ciphering mode

The SwMI is not required to send a layer 2 or layer 3 response to PDUs received from an MS with a ciphering mode differing from the ciphering mode negotiated with that MS.

The MS is not required to send a layer 2 or layer 3 response to PDUs received from the SwMI with a ciphering mode differing from the ciphering mode negotiated with that SwMI.

6.7.2 Service description and primitives

Each layer in the protocol stack provides a set of services to the layer above. This clause describes the services that are added to those provided by each layer due to the incorporation of encryption, in addition to those specified in EN 300 392-2 [2]. The primitives that are passed between the layers are also described.

The primitives required to control encryption are summarized in figure 56.

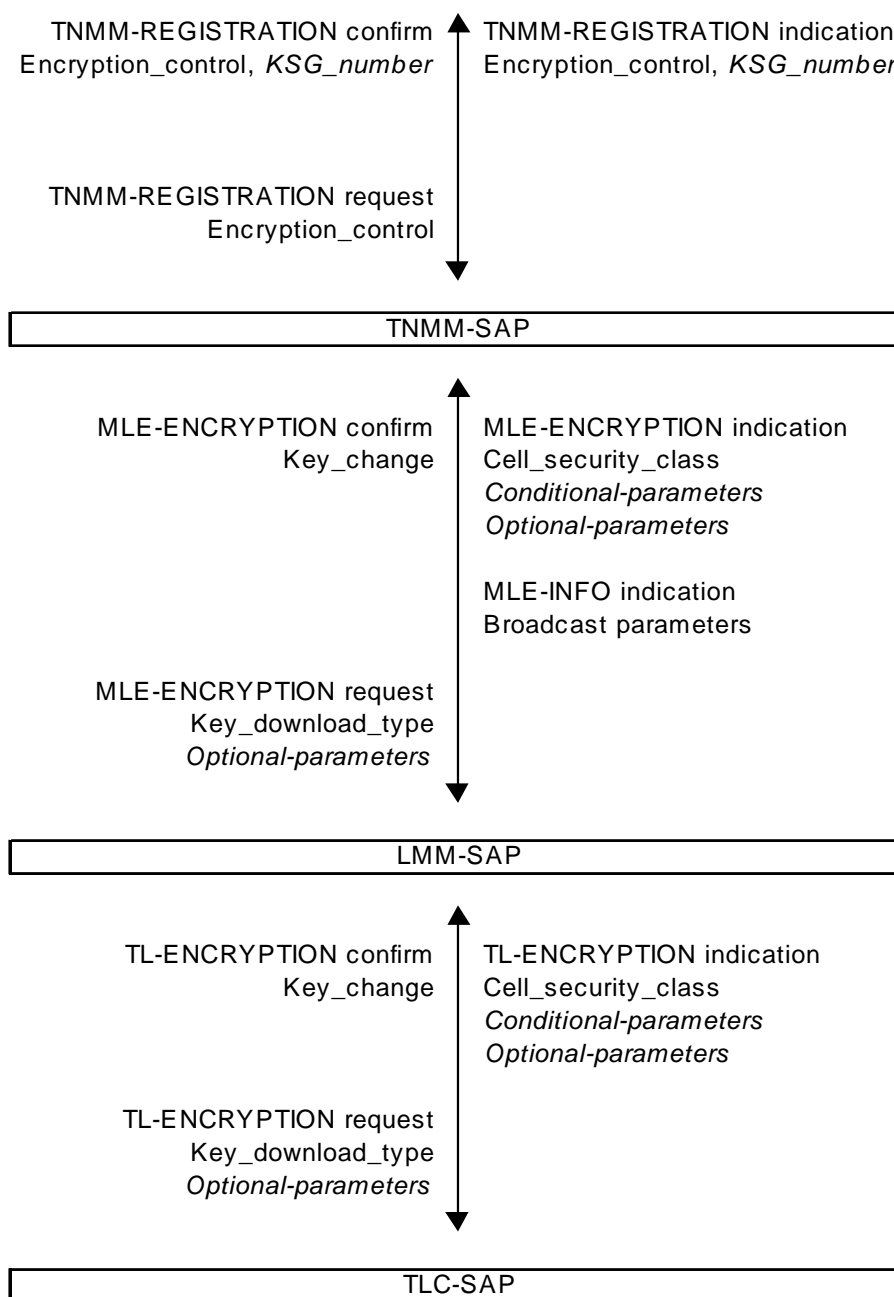

Figure 56: Protocol stack and primitives for encryption control

6.7.2.1 Mobility Management (MM)

TNMM SAP: the encryption control procedure shall only be invoked by the SwMI using the registration procedure. The MS-MM may indicate its current state, or a change of state, to the MS application.

The primitive TNMM-REGISTRATION shall contain the parameter "Encryption control" to enable/disable the encryption process, and the parameter "KSG number".

Table 18: TNMM-REGISTRATION parameters (c.f. EN 300 392-2 [2], clause 15.3.3.7)

Parameter	Request	Indication	Confirm
Registration Status	-	M	M
Registration Reject Cause (see note 1)	-	C	-
Registration Type	M	-	-
Location Area (see note 2)	C	-	-
MCC (see note 3)	C	-	-
MNC (see note 3)	C	-	-
ISSI or ASSI or USSI (see note 4)	M	-	-
Group identities	-	O	O
Group identity request	O	-	-
Group identity attach/detach mode	O	O	O
Group identity report	O	-	-
Encryption control	M	M	M
KSG number	-	O	O
Key: M = Mandatory; C = Conditional; O = Optional NOTE 1: Shall be present if Registration Status = "failure". NOTE 2: Shall be present if Registration Type = "No new ITSI - forward registration". NOTE 3: Shall be present if Registration Type = "New ITSI" or Registration Type = "No new ITSI - forward registration". NOTE 4: A previously established and valid ASSI may be used to prevent exposure of the ITSI at registration.			

6.7.2.2 Mobile Link Entity (MLE)

At the LMM SAP the following MLE services shall be provided to MM:

- loading of keys;
- start and stop ciphering.

These services shall be achieved by passing information to the MAC layer using the MLE-ENCRYPTION request primitive. The MAC shall indicate to MM the current CCK-id that is received in the broadcast SYSINFO PDU.

The MAC shall indicate to MM if the short CCK-id or short SCK-VN (in the MAC RESOURCE PDU) does not correspond to the CCK identifier or SCK-VN of the CCK or SCK that MLE is currently using. In addition the MAC shall indicate to MM if the encryption information received in SYSINFO has changed.

Table 19: MLE-ENCRYPTION parameters

Parameter	Request	Confirm	Indication
Key download type	M		-
KSG Number (see note 1)	O		-
SCK (see note 2)	C		-
DCK (see note 2)	C		-
CCK (see note 2)	C		-
CCK-id (see notes 2, 4)	C		C
SCK-VN	C		C
SCKN	C		C
MGCK (see note 2)	C		-
GTSI (see note 3)	C		-
xSSI (see note 5)	C		-
GSKO	C		
Cipher usage (see note 1)	O		-
Time (see note 6)	O		
Key change (see note 6)	-	M	-
Cell security class			M
Cell parameters changed			O
Key: M = Mandatory; C = Conditional; O = Optional NOTE 1: May be omitted if the state of the parameter has not changed from the previous request. NOTE 2: Key download type indicates which fields are present. NOTE 3: Provided if MGCK downloaded. NOTE 4: CCK-id supplied in indication. NOTE 5: This is the SSI associated with the DCK when DCK is downloaded. NOTE 6: If invoked from KEY CHANGE DEMAND.			

Key download type parameter indicates which encryption keys, if any, are downloaded to the MAC in this request.

- Key download type =
 - no keys downloaded;
 - SCK, SCKN, SCK-VN;
 - DCK, xSSI pair;
 - CCK, CCK-id, LA-id;
 - MGCK, GTSI;
 - GSKO.

KSG Number parameter indicates the Key Stream Generator (one of 16 possible) in use.

- KSG Number =
 - KSG 1;
 - KSG 2;
 - KSG 3;
 - ...
 - KSG 16.

Cipher usage parameter indicates to the MAC whether the transmitted messages should be encrypted and whether the MAC should try to decrypt received encrypted messages.

- Cipher usage =
 - encryption off;
 - RX;
 - RX and TX.

6.7.2.3 Layer 2

The layer 2 service shall load keys and start and stop the ciphering as required by the MM/MLE request. The MAC shall also be responsible for applying the correct key depending on the identity placed in the header of each MAC PDU. This is described in EN 300 392-2 [2], clause 21.

The corresponding MLE-ENCRYPTION request and indication should be passed through the LLC in a transparent way by using TL-ENCRYPTION request and indication respectively at the TLC-SAP, the boundary between the MLE and LLC. Similarly, the LLC should exchange the TM-ENCRYPTION request and indication at the TMC-SAP, the boundary between the LLC and the MAC.

In security class 3 the MAC shall indicate to MLE/MM the CCK-id of the current CCK in use in the cell. In security class 2, the MAC shall indicate the SCK-VN in use.

Encryption shall be performed in the upper MAC before FEC and interleaving.

6.7.3 Protocol functions

Each functional entity in the protocol stack shall communicate with its peer entity using a defined protocol; for example the MM entity in the MS communicates with its peer MM entity in the SwMI. The incorporation of encryption at the air interface requires additional functions to be added to some of the functional entities of the protocol stack. These functions shall be as described in the present clause.

6.7.3.1 MM

The protocol functions for air interface security shall be the following:

- ciphering type elements shall be contained in the U- and D- LOCATION UPDATE PDUs. A negotiation for ciphering types shall be performed in a re-registration if the parameters are not acceptable;
- MM may have to perform a re-registration if the SwMI requires a change in the encryption parameters including on-off control of encryption.

6.7.3.2 MLE

No encryption functionality shall be added to the MLE protocol. The management SAP (TLC-SAP) should be used inside the MS to deliver the new ciphering parameters to the MAC and to receive an indication of a change in the short SCK-VN (class 2) or CCK-id (class 3) from the MAC.

6.7.3.3 LLC

The LLC is used to control the encryption mode of BL-ACK/BL-ADATA/BL-ACK+DATA, etc.

No encryption functionality shall be added to the LLC protocol. The management SAP (TLC-SAP) should be used inside the MS to deliver the new ciphering parameters to the MAC and to receive an indication of a change in the short SCK-VN (class 2) or CCK-id (class 3) from the MAC.

6.7.3.4 MAC

The MAC shall indicate to MM a change in the SCKVN (Class 2) or CCK-id (Class 3) broadcast in MAC SYSINFO using the MLE-INFO primitive.

The MAC shall indicate to MM a change of security class broadcast in MAC SYSINFO using the MLE-INFO primitive.

6.7.4 PDUs for cipher negotiation

Ciphering elements shall be contained in the U-LOCATION UPDATE DEMAND, D-LOCATION UPDATE COMMAND, and the D-LOCATION UPDATE REJECT PDUs to permit negotiation of encryption parameters. These PDUs are described in EN 300 392-2 [2], clause 16.9.

The definition of reject cause is given in EN 300 392-2 [2], clause 16.10.42.

The MS-MM may suggest initial encryption parameters in the U-LOCATION UPDATE DEMAND PDU. The MS-MM shall assume that these parameters are acceptable and inform the MAC to use these parameters with the MLE-Encryption primitive. If the parameters are not acceptable the BS-MM shall reject them using the D-LOCATION UPDATE REJECT with reject cause set to one of:

- no cipher KSG;
- identified cipher KSG not available;
- requested cipher key type not available;
- identified cipher key not available;
- ciphering required.

If the encryption parameters are rejected the MS-MM shall use MLE-ENCRYPTION to inform the MAC to modify the parameters in accordance with the D-LOCATION UPDATE REJECT cause.

If the reject cause is "ciphering required" the MS may choose a set of parameters and send a new U-LOCATION UPDATE DEMAND or it may initiate the authentication process using the U-AUTHENTICATE DEMAND exchange described in clause 4.4.7.

NOTE: If the MS cannot negotiate compatible cipher parameters it should consider rejection, with one of these causes, to be rejection from the cell and not rejection from the complete SwMI. The MS may attempt cell reselection to find another cell where its security parameters may be acceptable.

Annex A (normative): PDU and element definitions

The PDUs detailed within this annex shall be visible at the Um reference point (see EN 300 392-1 [1], clause 5).

The general format and encoding rules are defined for all MM PDUs in EN 300 392-2 [2], clause 14.7.

A.1 Authentication PDUs

A.1.1 D-AUTHENTICATION demand

Shall be used by the infrastructure to initiate an authentication of the MS.

- Direction: SwMI to MS;
- Service used: MM;
- Response to: U-LOCATION UPDATE DEMAND or none;
- Response expected: U-AUTHENTICATION RESPONSE.

Table A.1: D-AUTHENTICATION DEMAND PDU contents

Information element	Length	Type	C/O/M	Remark
PDU Type	4	1	M	D-AUTHENTICATION
Authentication sub-type	2	1	M	DEMAND
Random challenge [RAND1]	80	1	M	
Random seed [RS]	80	1	M	
Proprietary element		3	O	

A.1.2 D-AUTHENTICATION reject

Shall be used by the infrastructure to report to the MS any rejection of an authentication demand.

- Direction: SwMI to MS;
- Service used: MM;
- Response to: U-AUTHENTICATION DEMAND or U-LOCATION UPDATE DEMAND containing RAND2;
- Response expected: none.

Table A.2: D-AUTHENTICATION REJECT PDU contents

Information element	Length	Type	C/O/M	Remark
PDU Type	4	1	M	D-AUTHENTICATION
Authentication sub-type	2	1	M	REJECT
Authentication reject reason	3	1	M	

A.1.3 D-AUTHENTICATION response

Shall be used by the infrastructure to respond to an authentication demand from the MS.

- Direction: SwMI to MS;
- Service used: MM;
- Response to: U-AUTHENTICATION DEMAND;
- Response expected: U-AUTHENTICATION RESULT.

Table A.3: D-AUTHENTICATION RESPONSE PDU contents

Information element	Length	Type	C/O/M	Remark
PDU Type	4	1	M	D-AUTHENTICATION
Authentication sub-type	2	1	M	RESPONSE
Random seed [RS]	80	1	M	
Response value [RES2]	32	1	M	
Mutual authentication flag	1	1	M	
Random challenge [RAND1]	80		C	See note
Proprietary element		3	O	
NOTE: RAND1 is conditional on the Mutual authentication flag element. RAND1 shall be present if Mutual authentication flag = 1. Otherwise, RAND1 shall not be present in the PDU.				

A.1.4 D-AUTHENTICATION result

Shall be used by the infrastructure to report the result of an MS authentication to the MS.

- Direction: SwMI to MS;
- Service used: MM;
- Response to: U-AUTHENTICATION RESPONSE or U-AUTHENTICATION RESULT;
- Response expected: U-AUTHENTICATION RESULT or none.

Table A.4: D-AUTHENTICATION RESULT PDU contents

Information element	Length	Type	C/O/M	Remark
PDU Type	4	1	M	D-AUTHENTICATION
Authentication sub-type	2	1	M	RESULT
Authentication result [R1]	1	1	M	
Mutual authentication flag	1	1	M	
Response Value [RES2]	32		C	See note
Proprietary element		3	O	
NOTE: RES2 is conditional on the Mutual authentication flag element. RES2 shall be present if Mutual authentication flag = 1. Otherwise, RES2 shall not be present in the PDU.				

A.1.5 U-AUTHENTICATION demand

Shall be used by the MS to initiate an authentication of the BS/SwMI.

- Direction: MS to SwMI;
- Service used: MM;
- Response to: none;
- Response expected: D-AUTHENTICATION RESPONSE or none.

Table A.5: U-AUTHENTICATION DEMAND PDU contents

Information element	Length	Type	C/O/M	Remark
PDU Type	4	1	M	U-AUTHENTICATION
Authentication sub-type	2	1	M	DEMAND
Random challenge [RAND2]	80	1	M	
Proprietary element		3	O	

A.1.6 U-AUTHENTICATION reject

Shall be used by the MS to report to the infrastructure rejection of an authentication demand which does not occur within the ENABLE/DISABLE protocol.

- Direction: MS to SwMI;
- Service used: MM;
- Response to: D-AUTHENTICATION DEMAND;
- Response expected: none.

Table A.6: U-AUTHENTICATION REJECT PDU contents

Information element	Length	Type	C/O/M	Remark
PDU Type	4	1	M	U-AUTHENTICATION
Authentication sub-type	2	1	M	REJECT
Authentication reject reason	3	1	M	

A.1.7 U-AUTHENTICATION response

Shall be used by MS-MM to respond to an authentication demand from the SwMI of the MS.

- Direction: MS to SwMI;
- Service used: MM;
- Response to: D-AUTHENTICATION DEMAND or D-ENABLE or D-DISABLE;
- Response expected: D-AUTHENTICATION RESULT.

Table A.7: U-AUTHENTICATION RESPONSE PDU contents

Information element	Length	Type	C/O/M	Remark
PDU Type	4	1	M	U-AUTHENTICATION
Authentication sub-type	2	1	M	RESPONSE
Response Value [RES1]	32	1	M	
Mutual authentication flag	1	1	M	
Random challenge [RAND2]	80		C	See note
Proprietary element		3	O	
NOTE: RAND2 is conditional on the Mutual authentication flag element. RAND2 shall be present if Mutual authentication flag = 1. Otherwise, RAND2 shall not be present in the PDU.				

A.1.8 U-AUTHENTICATION result

Shall be used by MS-MM to report the result of an authentication of the BS/SwMI.

- Direction: MS to SwMI;
- Service used: MM;
- Response to: D-AUTHENTICATION RESULT or D-AUTHENTICATION RESPONSE;
- Response expected: D-AUTHENTICATION RESULT or none.

Table A.8: U-AUTHENTICATION RESULT PDU contents

Information element	Length	Type	C/O/M	Remark
PDU Type	4	1	M	U-AUTHENTICATION
Authentication sub-type	2	1	M	RESULT
Authentication result [R2]	1	1	M	
Mutual authentication flag	1	1	M	
Response Value [RES1]	32		C	See note
Proprietary element		3	O	
NOTE: RES1 is conditional on the Mutual authentication flag element. RES1 shall be present if Mutual authentication flag = 1. Otherwise, RES1 shall not be present in the PDU.				

A.2 OTAR PDUs

A.2.1 D-OTAR CCK Provide

Shall be used by the infrastructure to provide CCK to an MS.

- Direction: SwMI to MS;
- Service used: MM;
- Response to: U-OTAR CCK Demand or none;
- Response expected: U-OTAR CCK Result or none.

Table A.9: D-OTAR CCK Provide PDU contents

Information element	Length	Type	C/O/M	Remark
PDU Type	4	1	M	D-OTAR
OTAR sub-type	4	1	M	CCK Provide
CCK provision flag	1	1	M	
CCK information	Varies		C	If CCK provision flag is true
Proprietary element		3	O	

A.2.2 U-OTAR CCK Demand

Shall be used by MS-MM to request CCK for a location area from the SwMI.

- Direction: MS to SwMI;
- Service used: MM;
- Response to: none;
- Response expected: D-OTAR CCK Provide.

Table A.10: U-OTAR CCK Demand PDU contents

Information element	Length	Type	C/O/M	Remark
PDU Type	4	1	M	U-OTAR
OTAR sub-type	4	1	M	CCK Demand
Location Area	14	1	M	
Proprietary element		3	O	

A.2.3 U-OTAR CCK Result

Shall be used by MS-MM to explicitly accept or reject some or all of the CCKs provided by the SwMI.

- Direction: MS to SwMI;
- Service used: MM;
- Response to: D-OTAR CCK Provide or D-LOCATION UPDATE ACCEPT containing *CCK Information*;
- Response expected: none.

Table A.11: U-OTAR CCK Result PDU contents

Information element	Length	Type	C/O/M	Remark
PDU Type	4	1	M	U-OTAR
OTAR sub-type	4	1	M	CCK Result
Provision result	3	1	M	Provision result for CCK
Future key flag	1	1	M	
Provision result (Future key)	3		C	If future key flag is true (see note)
Proprietary element		3	O	
NOTE: If D-OTAR CCK Provide or D-LOCATION UPDATE ACCEPT gives both current and future CCK then this flag is set true and this PDU shall contain two provision result fields. If D-OTAR CCK Provide PDU or D-LOCATION UPDATE ACCEPT provides only a future CCK then this flag shall be false.				

A.2.4 D-OTAR GCK Provide

Shall be used by the infrastructure to provide GCK to an MS.

- Direction: SwMI to MS;
- Service used: MM;
- Response to: U-OTAR GCK Demand or none;
- Response expected: U-OTAR GCK Result.

Table A.12: D-OTAR GCK Provide PDU contents

Information element	Length	Type	C/O/M	Remark
PDU type	4	1	M	D-OTAR
OTAR sub-type	4	1	M	GCK Provide.
Acknowledgement flag	1	1	M	If "0" No acknowledgement required If "1" Acknowledgement required
Reserved	1		C	Provided if Acknowledgement flag set to "0"
Explicit response (see note 1)	1		C	Provided if Acknowledgement flag set to "1"
Max response timer value	16	1	M	Identifies the maximum period of timer T371 over which the MS will randomly choose to respond
Session key	1	1	M	Identifies if encrypted with group or individual encryption session key
Random Seed for OTAR	80		C	Provided if session key for individual
GSKO-VN	16		C	Provided if session key for group
Number of GCKs provided	3		M	See note 2
GCK key and identifier	152		C	See note 3
KSG number	4	1	M	Associates GCK to a particular encryption algorithm
Group association	1	1	M	
GSSI	24		C	If Group association = GSSI
OTAR retry interval	3	1	M	See note 4
Address extension	24	2	O	See note 5
Proprietary element		3	O	
<p>NOTE 1: If the "explicit response" element = 1, the MS shall respond whether the key provide changes the MS state or not; if "explicit response" = 0, the MS shall only respond if the SwMI provides a key or key version that the MS did not previously have. The "explicit response" element is only valid if "Acknowledgment field" is set to "1" the "explicit response" element = 1, the MS shall respond whether the key provide changes the MS state or not; if "explicit response" = 0, the MS shall only respond if the SwMI provides a key or key version that the MS did not previously have.</p> <p>NOTE 2: The number of GCKs provided may not be the same as the number of GCKs originally requested.</p> <p>NOTE 3: This element is repeated according to "Number of GCKs provided" value. If "Number of GCKs provided" = 0, there shall be no "GCK key and identifier" elements in the PDU.</p> <p>NOTE 4: Where group association indicates GSSI the provided GCKs shall all have the GCKN associated with the indicated GSSI and shall have different GCK-VNs.</p> <p>NOTE 5: The address extension element shall be present only if the network code for which the provided GCK relates is different to the serving network.</p>				

A.2.5 U-OTAR GCK Demand

Shall be used by the MS to request GCKs from the SwMI.

- Direction: MS to SwMI;
- Service used: MM;
- Response to: none;
- Response expected: D-OTAR GCK Provide.

Table A.13: U-OTAR GCK Demand PDU contents

Information element	Length	Type	C/O/M	Remark
PDU Type	4	1	M	U-OTAR
OTAR sub-type	4	1	M	GCK Demand
KSG number	4	1	M	Associates GCK with a particular encryption algorithm
Number of GCKs requested by GCKN	3	1	M	See note 1
GCKN	16		C	Shall be repeated the number of times indicated by the "Number of GCKs requested by GCKN" information element
Number of GCKs requested by GSSI	3	1	M	See note 1
GSSI	24		C	Shall be repeated the number of times indicated by the "Number of GCKs requested by GSSI" information element
Address Extension	24	2	O	See note 2
Proprietary element		3	O	
NOTE 1: The total number of GCKs requested in this PDU (i.e. the sum of these elements) shall not be zero and shall not exceed seven.				
NOTE 2: The address extension element shall be present only if the network code for which the requested GCK relates is different to the serving network.				

A.2.6 U-OTAR GCK Result

Shall be used by MS-MM to explicitly accept or reject a GCK provided by the SwMI.

- Direction: MS to SwMI;
- Service used: MM;
- Response to: D-OTAR GCK Provide;
- Response expected: none.

Table A.14: U-OTAR GCK Result PDU contents

Information element	Length	Type	C/O/M	Remark
PDU Type	4	1	M	U-OTAR
OTAR sub-type	4	1	M	GCK Result
Number of GCKs provided	3	1	M	
GCK provision result	Varies		C	Repeated according to Number of GCKs provided value
Address Extension	24	2	O	See note
Proprietary element		3	O	
NOTE: The address extension element shall be present only if the network code for which the provided GCK relates is different to the serving network.				

A.2.6a D-OTAR GCK Reject

Shall be used by the infrastructure to explicitly reject GCK requests from an MS.

- Direction: SwMI to MS;
- Service used: MM;
- Response to: U-OTAR GCK Demand.

Table A.15: D-OTAR GCK Reject PDU contents

Information element	Length	Type	C/O/M	Remark
PDU type	4	1	M	D-OTAR
OTAR sub-type	4	1	M	GCK Reject
Number of GCKs rejected	3	1	M	
GCK rejected	Varies		C	See note 1
OTAR Retry Interval	3	1	M	
Address Extension	24	2	O	See note 2
Proprietary element		3	O	
NOTE 1: This element is repeated according to the "Number of GCKs rejected" value.				
NOTE 2: The address extension element shall be present only if the network code for which the provided GCK relates is different to the serving network.				

A.2.7 D-OTAR SCK Provide

Shall be used by the infrastructure to provide SCK to an MS.

- Direction: SwMI to MS;
- Service used: MM;
- Response to: U-OTAR SCK Demand or none;
- Response expected: U-OTAR SCK Result.

Table A.16: D-OTAR SCK Provide PDU contents

Information element	Length	Type	C/O/M	Remark
PDU Type	4	1	M	D-OTAR
OTAR sub-type	4	1	M	SCK Provide
Acknowledgement flag	1	1	M	If "0" No acknowledgement required If "1" Acknowledgement required
Reserved	1		C	Provided if Acknowledgement flag set to "0"
Explicit response (see note 1)	1		C	Provided if Acknowledgement flag set to "1"
Max response timer value	16	1	M	Identifies the maximum period over which the MS will randomly choose to respond
Session key	1	1	M	Identifies if encrypted with group or individual encryption session key
Random seed for OTAR	80		C	Provided if session key for individual
GSKO-VN	16		C	Provided if session key for group
Number of SCKs provided	3	1	M	See note 2
SCK key and identifier	143		C	See note 3
KSG number	4	1	M	Associates SCK with a particular encryption algorithm
OTAR Retry Interval	3	1	M	
Address Extension	24	2	O	See note 4
Proprietary element		3	O	
NOTE 1: If the "explicit response" element = 1, the MS shall respond whether the key provide changes the MS state or not; if "explicit response" = 0, the MS shall only respond if the SwMI provides a key or key version that the MS did not previously have.				
NOTE 2: The number of SCKs provided may not be the same as the number of SCKs originally requested.				
NOTE 3: This element is repeated according to "Number of SCKs provided" value. If "Number of SCKs provided" = 0, there shall be no "SCK key and identifier" elements in the PDU.				
NOTE 4: The address extension element shall be present only if the network code for which the provided SCK relates is different to the serving network.				

A.2.8 U-OTAR SCK Demand

Shall be used by the MS to request SCK from the SwMI.

- Direction: MS to SwMI;
- Service used: MM;
- Response to: none;
- Response expected: D-OTAR SCK Provide.

Table A.17: U-OTAR SCK Demand PDU contents

Information element	Length	Type	C/O/M	Remark
PDU Type	4	1	M	U-OTAR
OTAR sub-type	4	1	M	SCK Demand
KSG number	4	1	M	Associates SCK with a particular encryption algorithm
Number of SCKs requested	3	1	M	
SCK number (SCKN)	5		C	See note 1
Address Extension	24	2	O	See note 2
Proprietary element		3	O	
NOTE 1: This element is repeated according to the "Number of SCKs element. Requested" value.				
NOTE 2: The address extension element shall be present only if the network code for which the requested SCK relates is different to the serving network.				

A.2.9 U-OTAR SCK Result

Shall be used by MS-MM to explicitly accept or reject the SCKs provided by the SwMI.

- Direction: MS to SwMI;
- Service used: MM;
- Response to: D-OTAR SCK Provide or D-LOCATION UPDATE ACCEPT containing *SCK Information*;
- Response expected: none.

Table A.18: U-OTAR SCK Result PDU contents

Information element	Length	Type	C/O/M	Remark
PDU Type	4	1	M	U-OTAR
OTAR sub-type	4	1	M	SCK Result
Number of SCKs provided	3	1	M	
SCK number and result	Varies		C	See note 1
Address Extension	24	2	O	See note 2
Proprietary element		3	O	
NOTE 1: This element is repeated according to the "Number of SCKs provided" value.				
NOTE 2: The address extension element shall be present only if the network code for which the requested SCK relates is different to the serving network.				

A.2.9a D-OTAR SCK Reject

Shall be used by the infrastructure to reject provision of SCK to an MS.

- Direction: SwMI to MS;
- Service used: MM;
- Response to: U-OTAR SCK Demand;
- Response expected: none.

Table A.19: D-OTAR SCK Reject PDU contents

Information element	Length	Type	C/O/M	Remark
PDU Type	4	1	M	D-OTAR
OTAR sub-type	4	1	M	SCK Reject
Number of SCKs rejected	3	1	M	
SCK rejected	8		C	See note 1
OTAR Retry Interval	3	1	M	
Address Extension	24	2	O	See note 2
Proprietary element		3	O	
NOTE 1: This element is repeated according to the "Number of SCKs rejected" value. Each rejected SCK shall be associated with its own OTAR reject reason.				
NOTE 2: The address extension element shall be present only if the network code for which the requested SCK relates is different to the serving network.				

A.2.10 D-OTAR GSKO Provide

Shall be used by the infrastructure to provide GSKO and CMG GTSI to an MS.

- Direction: SwMI to MS;
- Service used: MM;
- Response to: U-OTAR GSKO Demand or none;
- Response expected: U-OTAR GSKO Result.

Table A.20: D-OTAR GSKO Provide PDU contents

Information element	Length	Type	C/O/M	Remark
PDU Type	4	1	M	D-OTAR
OTAR sub-type	4	1	M	GSKO Provide
Random seed for OTAR	80	1	M	
GSKO-VN	16	1	M	
Sealed GSKO	120	1	M	
GSSI	24	1	M	
Address extension (see note)	24	2	O	
Proprietary element		3	O	
NOTE: The address extension element shall be present only if the network code for which the provided GSKO relates is different to the serving network.				

A.2.11 U-OTAR GSKO Demand

Shall be used by the MS to request GSKO from the SwMI.

- Direction: MS to SwMI;
- Service used: MM;
- Response to: none;
- Response expected: D-OTAR GSKO Provide.

Table A.21: U-OTAR GSKO Demand PDU contents

Information element	Length	Type	C/O/M	Remark
PDU Type	4	1	M	U-OTAR
OTAR sub-type	4	1	M	GSKO Demand
Address extension (see note)	24	2	O	
Proprietary element		3	O	
NOTE: The address extension element shall be present only if the network code for which the requested GSKO relates is different to the serving network.				

A.2.12 U-OTAR GSKO Result

Shall be used by MS-MM to explicitly accept or reject the GSKO and CMG GTSI provided by the SwMI.

- Direction: MS to SwMI;
- Service used: MM;
- Response to: D-OTAR GSKO Provide;
- Response expected: none.

Table A.22: U-OTAR GSKO Result PDU contents

Information element	Length	Type	C/O/M	Remark
PDU Type	4	1	M	U-OTAR
OTAR sub-type	4	1	M	GSKO Result
GSKO-VN	16	1	M	
Provision result	3	1	M	
GSSI	24	1	M	
Address extension (see note)	24	2	O	
Proprietary element		3	O	
NOTE: The address extension element shall be present only if the network code for which the provided GSKO relates is different to the serving network.				

A.2.12a D-OTAR GSKO Reject

Shall be used by the infrastructure to reject provision of GSKO to an MS.

- Direction: SwMI to MS;
- Service used: MM;
- Response to: U-OTAR GSKO Demand;
- Response expected: none.

Table A.23: D-OTAR GSKO Reject PDU contents

Information element	Length	Type	C/O/M	Remark
PDU Type	4	1	M	D-OTAR
OTAR sub-type	4	1	M	GSKO Reject
OTAR reject reason	3	1	M	
GSSI	24	1	M	
OTAR Retry Interval	3	1	M	
Address extension (see note)	24	2	O	
Proprietary element		3	O	
NOTE: The address extension element shall be present only if the network code for which the provided GSKO relates is different to the serving network.				

A.3 PDUs for key association to GTSI

A.3.1 D-OTAR KEY ASSOCIATE demand

Shall be used by SwMI to associate or disassociate a cipher key with one or more groups.

- Direction: SwMI to MS;
- Service used: MM;
- Response to: none;
- Response expected: U-OTAR KEY ASSOCIATE STATUS or none.

Table A.24: D-OTAR KEY ASSOCIATE demand contents

Information element	Length	Type	C/O/M	Remark
PDU Type	4	1	M	D-OTAR
OTAR sub type	4	1	M	Key associate demand
Acknowledgement flag	1	1	M	If "0" No acknowledgement required If "1" Acknowledgement required
Explicit response (see note 3)	1	1	M	If "0" MS shall respond if state changes. If "1" MS shall always respond
Max response timer value	16	1	M	Identifies the maximum period over which the MS will randomly choose to respond
Key association type	1	1	M	SCK (0), GCK (1)
SCK select number	6		C	Provided if key type = SCK
SCK subset grouping type	4		C	Provided if key type = SCK
GCK select number	17		C	Provided if key type = GCK
Number of groups	5	1	M	(0) reserved, (1 to 30) number of groups, (31) range of groups
GSSI (see note 1)	24		C	Repeated element
Address extension (see note 2)	24	2	O	
NOTE 1: The GSSI element is repeated; total number GSSI elements = value of "Number groups" element. For 0 < Number of Groups < 31; = 2 for Number of Groups = 31, and GSSI elements shall contain the lowest followed by the highest value GSSI in the range. GSSI can only be provided for a single network within the same PDU.				
NOTE 2: The address extension element is only present if the network code for which the provided GSSIs relate is different to the serving network.				
NOTE 3: The "explicit response" element is only valid if "Acknowledgment field" is set to "1".				

A.3.2 U-OTAR KEY ASSOCIATE status

Shall be used by MS to indicate successful association or disassociation of a cipher key with one or more groups.

- Direction: MS to SwMI;
- Service used: MM;
- Response to: D-OTAR KEY ASSOCIATE DEMAND
- Response expected: none.

Table A.25: U-OTAR KEY ASSOCIATE STATUS contents

Information element	Length	Type	C/O/M	Remark
PDU Type	4	1	M	U-OTAR
OTAR sub type	4	1	M	Key associate status
Key association type	1	1	M	SCK (0), GCK (1)
SCK subset grouping type	4		C	Provided if key type = SCK
Key association status	3	1	M	
Number of groups	5		C	Provided if "Key association status" = "Address not valid", and indicates the number of GSSI fields that follow. Valid range = 1 to 30
GSSI	24		C	Provided if "Key association status" = "Address not valid". Element is repeated the number of times indicated by the value of the "Number of groups" element and contains each unknown address
Address extension (see note)	24	2	O	
NOTE: The address extension element is only present if the network code for which the provided GSSIs relate is different to the serving network.				

A.4 PDUs to synchronize key or security class change

A.4.1 D-CK CHANGE demand

Shall be used by SwMI to indicate a cipher key change either in the future or immediately.

- Direction: SwMI to MS;
- Service used: MM;
- Response to: none;
- Response expected: U-CK CHANGE RESULT or none.

Table A.26: D-CK CHANGE DEMAND contents

Information element	Length	Type	C/O/M	Remark
PDU Type	4	1	M	D-CK CHANGE DEMAND
Acknowledgement flag	1	1	M	If "0" No acknowledgement required If "1" Acknowledgement required
Change of Security Class	2	1	M	
Key change type	3	1	M	
SCK use	1		C	Provided if key change type = SCK; "0" = TMO, "1" = DMO
Number of SCKs changed	4		C	Provided if key change type = SCK; (0000) indicates subset of SCKs; (1) to (1111) indicate number of single SCKs to follow
SCK subset grouping type	4		C	Provided if SCK use = DMO and Number of SCKs changed = 0
SCK subset number	5		C	Provided if SCK use = DMO and Number of SCKs changed = 0
SCK-VN	16		C	Provided if SCK use = DMO and Number of SCKs changed = 0
SCK data (see note 1)	21		C	Provided if key change type = SCK; and Number of SCKs = 1 to 1111; repeated element
CCK-id	16		C	Provided if key change type = CCK, or if key change type = "Class 3 CCK and GCK activation"
Number of GCKs changed	4		C	Provided if key change type = GCK; Reserved (0000 ₂)
GCK data (see note 1)	32		C	Provided if key change type = GCK; repeated element
GCK-VN	16		C	Provided if key change type = All GCK, or if key change type = "Class 3 CCK and GCK activation"
Time type	2	1	M	
Slot number	2		C	Provided if time type = Absolute IV
Frame number	5		C	Provided if time type = Absolute IV
Multiframe number	6		C	Provided if time type = Absolute IV
Hyperframe number	16		C	Provided if time type = Absolute IV
Network time (see note 2)	48		C	Provided if time type = network time
NOTE 1: The SCK data or GCK data elements are repeated; total number of SCK data or GCK data elements = value of "Number of SCKs changed" or value of "Number of GCKs changed" element.				
NOTE 2: As specified in EN 300 392-2 [2], clause 18.5.24.				

A.4.2 U-CK CHANGE result

Shall be used by MS-MM to inform the SwMI that it has registered the required cipher key change.

- Direction: MS to SwMI;
- Service used: MM;
- Response to: D-CK CHANGE DEMAND;
- Response expected: none.

Table A.27: U-CK CHANGE RESULT contents

Information element	Length	Type	C/O/M	Remark
PDU Type	4	1	M	U-CK CHANGE RESULT
Change of Security Class	2	1	M	
Key change type	3	1	M	If "change of security class" is "transition to security class 1" then this element is set to "no cipher key"
SCK use	1		C	Provided if key change type = SCK; "0" = TMO, "1" = DMO
Number of SCKs changed	4		C	Provided if key change type = SCK; indicates the number of SCK data elements to follow
SCK subset grouping type	4		C	Provided if SCK use = DMO; and Number of SCKs = 0
SCK subset number	5		C	Provided if SCK use = DMO; and Number of SCKs = 0
SCK-VN	16		C	Provided If SCK use = DMO; and Number of SCKs = 0
SCK data (see note)	21		C	Provided if key change type = SCK; repeated element
CCK-id	16		C	Provided if key change type = CCK
Number of GCKs changed	4		C	Provided if key change type = GCK
GCK data (see note)	32		C	Provided if key change type = GCK; repeated element
GCK-VN	16		C	Provided if key change type = All GCK
NOTE:	The SCK data or GCK data elements are repeated to inform the SwMI of all keys that have been successfully selected. This may not be the same number as demanded by the SwMI.			

A.4a PDUs to delete air interface keys in MS

A.4a.1 D-OTAR KEY DELETE demand

Shall be used by the SwMI to delete air interface key material from the MS.

- Direction: SwMI to MS;
- Service used: MM;
- Response to: none;
- Response expected: U-OTAR KEY DELETE RESULT or none.

Table A.27a: D-OTAR KEY DELETE demand contents

Information element	Length	Type	C/O/M	Remark
PDU Type	4	1	M	D-OTAR
OTAR sub-type	4	1	M	Key Delete Demand
Key delete type	3	1	M	
Number of SCKs deleted	5		C	Provided if key delete type = (000) or (001), individual SCK(s) or members of a KAG; indicates number of SCKN elements to follow
SCKN	5		C	Provided if key delete type = (000) or (001), individual SCK(s) or members of a KAG; Repeated element, number of elements corresponds to value of Number of SCKs deleted element
SCK subset grouping type	4		C	Provided if key delete type = (010), SCK subset
SCK subset number	5		C	Provided if key delete type = (010), SCK subset; Value corresponds to subset number to be deleted
Number of GCKs deleted	4		C	Provided if key delete type = (100) individual GCK(s)
GCKN	16		C	Provided if key delete type = (100), individual GCK(s); Repeated element, number of elements corresponds to value of Number of GCKs deleted element
Address extension (see note 1)	24	2	O	
NOTE 1: The address extension element shall be present only if the network code for which the deleted key relates is different to the serving network.				
NOTE 2: If key delete type = 001, members of a KAG, the MS shall delete all other SCKNs in other subsets that correspond with the SCKN listed for deletion by the SwMI in this PDU.				

A.4a.2 U-OTAR KEY DELETE result

Shall be used by MS-MM to inform the SwMI that it has deleted the required cipher keys.

- Direction: MS to SwMI;
- Service used: MM;
- Response to: D-OTAR Key Delete Demand;
- Response expected: none.

Table A.27b: U-OTAR KEY DELETE result contents

Information element	Length	Type	C/O/M	Remark
PDU Type	4	1	M	U-OTAR
OTAR sub-type	4	1	M	Key Delete Result
Key delete type	3	1	M	
Number of SCKs deleted	5		C	Provided if key delete type = (000) or (001), individual SCK(s) or members of a KAG; (00000) to (11111) indicate number of individual SCKs to follow
SCKN	5		C	Provided if key delete type = (000) or (001), individual SCK(s) or members of a KAG; Repeated element, number of elements corresponds to value of Number of SCKs deleted element
SCK subset grouping type	4		C	Provided if key delete type = (010) or (001), SCK subset or members of a KAG
SCK subset number	5		C	Provided if key delete type = (010), SCK subset; Value corresponds to subset number to be deleted
Number of GCKs deleted	4		C	Provided if key delete type = (100) individual GCK(s)
GCKN	16		C	Provided if key delete type = (100), individual GCK(s); Repeated element, number of elements corresponds to value of Number of GCKs deleted element
GSKO-VN	16		C	Provided if key delete type = (110), GSKO
Address extension (see note 2)	24	2	O	
NOTE 1: The address extension element shall be present only if the network code for which the deleted key relates is different to the serving network.				
NOTE 2: If the MS sets key delete type = 001, members of a KAG, the MS shall indicate that all other SCKNs in other subsets that correspond with the SCKN listed in this PDU have been deleted.				

A.4b PDUs to obtain Air Interface Key Status

A.4b.1 D-OTAR KEY STATUS demand

Shall be used by the SwMI to discover the current numbers and versions of air interface keys held by an MS by means of a status enquiry. May be used to allow a SwMI to maintain a record of the MS keying state without needing to explicitly update the MS with new key material to force a response.

- Direction: SwMI to MS;
- Service used: MM;
- Response to: none;
- Response expected: U-OTAR Key Status Response or none.

Table A.27c: D-OTAR KEY STATUS demand contents

Information element	Length	Type	C/O/M	Remark
PDU Type	4	1	M	D-OTAR
OTAR sub-type	4	1	M	Key Status Demand
Acknowledgement flag	1	1	M	If "0" No acknowledgement required If "1" Acknowledgement required
Explicit response (see note 1)	1	1	M	If "0" MS shall respond if state changes. If "1" MS shall always respond
Max response timer value	16	1	M	Identifies the maximum period over which the MS will randomly choose to respond
Key status type	3	1	M	
SCKN	5		C	If Key status type = (000), SCK
SCK subset grouping type	4		C	If Key status type = (001), SCK subset
SCK subset number	5		C	If Key status type = (001), SCK subset
GCKN	16		C	If Key status type = (011), GCK
Address extension (see note 2)	24	2	O	
NOTE 1: The "explicit response" element is only valid if "Acknowledgment field" is set to "1".				
NOTE 2: The address extension element shall be present only if the network code for which the requested key relates is different to the serving network.				

A.4b.2 U-OTAR KEY STATUS response

Shall be used by the MS to respond to the SwMI's request to report the current numbers and versions of air interface keys held by the MS.

- Direction: MS to SwMI;
- Service used: MM;
- Response to: D-OTAR Key Status Demand;
- Response expected: none.

Table A.27d: U-OTAR KEY STATUS RESPONSE contents

Information element	Length	Type	C/O/M	Remark
PDU Type	4	1	M	U-OTAR
OTAR sub-type	4	1	M	Key Status Response
Key status type	3	1	M	
SCK subset grouping type	4	1	C	Provided if key status type = (001), SCK subset
SCK subset number	5		C	Provided if key status type = (001), SCK subset
Number of SCK status	6		C	Provided if key status type = (000, 001 or 010), SCK, SCK subset or all SCKs
SCK data	21		C	Provided if key status type = (000, 001 or 010), SCK, SCK subset or all SCKs; repeated element
Number of GCK status	5		C	Provided if key status type = (011 or 100), GCK or all GCKs
GCK data	32		C	Provided if key status type = (011 or 100), GCK or all GCKs; repeated element
Number of GSKO status	2		C	Provided if key status type = (101), GSKO
GSKO-VN	16		C	Provided if key status type = (101), GSKO, repeated element
Address extension (see note 4)	24	2	O	
NOTE 1: The number of "SCK data" elements following the "Number of SCK status" element shall be the same as the value of the "Number of SCK status" element. If MS has no SCKs, or does not have the requested SCK, no "SCK data" elements shall be sent.				
NOTE 2: The number of "GCK data" elements following the "Number of GCK status" element shall be the same as the value of the "Number of GCK status" element. If the MS has no GCKs, or does not have the requested SCK, no "GCK data" elements shall be sent.				
NOTE 3: The number of "GSKO-VN" elements following the "Number of GSKO status" element shall be the same as the value of the "Number of GSKO status" element. If the MS has no GSKOs, no "GSKO-VN" elements shall be sent.				
NOTE 4: The address extension element shall be present only if the network code for which the requested key relates is different to the serving network.				

A.5 Other security domain PDUs

A.5.1 U-TEI PROVIDE

Shall be used by MS-MM to inform the SwMI of its terminal equipment identifier.

- Direction: MS to SwMI;
- Service used: MM;
- Response to: D-LOCATION UPDATE ACCEPT;
- Response expected: none.

Table A.28: U-TEI PROVIDE PDU contents

Information element	Length	Type	C/O/M	Remark
PDU Type	4	1	M	U-TEI PROVIDE
TEI	60	1	M	
SSI	24	1	M	
Address extension	24	2	O	
Proprietary element		3	O	

A.5.2 U-OTAR PREPARE

Shall be used by MS-MM to inform the SwMI that it intends to change to a new cell.

- Direction: MS to SwMI;
- Service used: MM;
- Response to: none;
- Response expected: D-OTAR NEWCELL.

Table A.29: U-OTAR PREPARE

Information element	Length	Type	C/O/M	Remark
PDU Type	4	1	M	U-OTAR
OTAR sub-type	4	1	M	OTAR PREPARE
Location Area	14	1	M	The Location Area of the preferred neighbour cell
CCK request flag	1	1	M	
Proprietary element		3	O	

A.5.3 D-OTAR NEWCELL

Shall be used by SwMI to inform the MS of the result of the U-OTAR PREPARE exchange.

- Direction: SwMI to MS;
- Service used: MM;
- Response to: U-OTAR PREPARE;
- Response expected: none.

Table A.30: D-OTAR NEWCELL

Information element	Length	Type	C/O/M	Remark
PDU Type	4	1	M	D-OTAR
OTAR sub-type	4	1	M	OTAR NEWCELL
DCK Forwarding Result	1	1	M	
CCK provision flag	1	1	M	
CCK information	Varies		C	
Proprietary element		3	O	

A.5.4 D-OTAR CMG GTSI PROVIDE

Shall be used by SwMI to provide a GTSI to be used for group addressed OTAR functions.

- Direction: SwMI to MS;
- Service used: MM;
- Response to: none;
- Response expected: U-OTAR CMG GTSI RESULT or none.

Table A.30a: D-OTAR CMG GTSI PROVIDE contents

Information element	Length	Type	C/O/M	Remark
PDU Type	4	1	M	D-OTAR
OTAR sub type	4	1	M	CMG GTSI PROVIDE
GSSI	24	1	M	
Address extension (see note)	24	2	O	
NOTE: The address extension element is only present if the network code for which the provided GSSI relates is different to the serving network.				

A.5.5 U-OTAR CMG GTSI RESULT

Shall be used by MS to indicate successful reception of a GSSI or GTSI to be used to receive group addressed OTAR functions.

- Direction: MS to SwMI;
- Service used: MM;
- Response to: D-OTAR CMG GTSI PROVIDE
- Response expected: none.

Table A.30b: U-OTAR CMG GTSI RESULT contents

Information element	Length	Type	C/O/M	Remark
PDU Type	4	1	M	U-OTAR
OTAR sub type	4	1	M	CMG GTSI RESULT
GSSI	24	1	M	
Address extension (see note)	24	2	O	
NOTE: The address extension element is only present if the network code for which the provided GSSI relates is different to the serving network.				

A.6 PDUs for Enable and Disable

A.6.1 D-DISABLE

This message is sent by the Infrastructure to indicate that the mobile station shall be disabled (permanently or temporarily).

- Direction: SwMI to MS;
- Service used: MM;
- Response to: -;
- Response expected: U-DISABLE STATUS or U-AUTHENTICATION RESPONSE.

Table A.31: D-DISABLE contents

Information element	Length	Type	C/O/M	Remark
PDU Type	4	1	M	D-DISABLE
Intent/Confirm	1	1	M	Intent or confirm
Disabling type	1	1	M	Temporary or permanent
Equipment disable	1	1	M	Disable equipment
TETRA Equipment Identity	60		C	Present if equipment disable = 1
Subscription disable	1	1	M	Disable subscription
Address Extension	24		C	Present if Subscription disable = 1
SSI	24		C	Present if Subscription disable = 1
Authentication challenge	160	2	O	
Proprietary		3	O	

A.6.2 D-ENABLE

This message is sent by the Infrastructure to indicate that the mobile station shall be enabled after a disable.

- Direction: SwMI to MS;
- Service used: MM;
- Response to: -;
- Response expected: U-DISABLE STATUS or U-AUTHENTICATION RESPONSE.

Table A.32: D-ENABLE contents

Information element	Length	Type	C/O/M	Remark
PDU Type	4	1	M	D-ENABLE
Intent/Confirm	1	1	M	Intent or confirm
Equipment enable	1	1	M	Enable of equipment
TETRA Equipment Identity	60		C	Present if equipment enable = 1
Subscription enable	1	1	M	Enable of subscription
Address Extension	24		C	Present if Subscription enable = 1
SSI	24		C	Present if Subscription enable = 1
Authentication challenge	160	2	O	
Proprietary		3	O	

A.6.3 U-DISABLE STATUS

This message is sent by the mobile station to inform the infrastructure of its response to an enable or disable request and its resulting status.

- Direction: MS to SwMI;
- Service used: MM;
- Response to: D-DISABLE or D-ENABLE;
- Response expected: none.

Table A.33: U-DISABLE STATUS contents

Information element	Length	Type	C/O/M	Remark
PDU Type	4	1	M	U-DISABLE STATUS
Equipment status	2	1	M	Indicates disabled state of equipment
Subscription status	2	1	M	Indicates disabled state of subscription
Enable/Disable result	3	1	M	
Address Extension	24	2	O	Present only if in response to enable/disable of subscription
SSI	24	2	O	Present only if in response to enable/disable of subscription
TETRA Equipment Identity	60	2	O	Present only if in response to enable/disable of equipment
Proprietary		3	O	

A.7 MM PDU type 3 information elements coding

The authentication mechanisms may be combined with the normal and SwMI-initiated registration procedures as shown in MSC scenarios in clause 4. Therefore, type 3 elements are defined which carry the authentication information and which can be appended to the MM registration PDUs. These type 3 elements shall be as defined in this clause.

A.7.1 Authentication downlink

This type 3 element shall be appended to D-LOCATION UPDATE ACCEPT to inform the MS about the result of an authentication procedure which has been combined with registration and/or to request that an MS supplies its TEI and/or to supply the MS with CCK information (class 3) or SCK information (class 2) for the cell to which it is registering.

- Direction: SwMI to MS;
- MM PDU: D-LOCATION UPDATE ACCEPT;
- Response to: U-AUTHENTICATION RESPONSE;
- Response expected: none.

Table A.34: Authentication downlink element contents

Information element	Length	Type	C/O/M	Remark
Authentication result [R1]	1	1	M	Only valid for authentication exchanges
TEI request flag	1	1	M	
CK provision flag	1	1	M	
CK provision information	Varies		C	Provided if CK provision flag = TRUE

A.7.2 Authentication uplink

This type 3 element shall be appended to U-LOCATION UPDATE DEMAND when the MS combines a registration request with a request to authenticate the SwMI or when the MS requests the CCK (class 3) or SCK (class 2) information for the cell to which it is registering.

- Direction: MS to SwMI;
- MM PDU: U-LOCATION UPDATE DEMAND;
- Response to: D-LOCATION UPDATE COMMAND or none;
- Response expected: D-AUTHENTICATION RESPONSE.

Table A.35: Authentication uplink element contents

Information element	Length	Type	C/O/M	Remark
CK request flag	1	1	M	If this is TRUE then the CK requested shall be implied by the security class field in ciphering parameters
Random challenge [RAND2]	80	2	O	

A.8 PDU Information elements coding

The encoding of the information elements and sub-elements for the PDUs described in clauses A.1 to A.7 are given in the following clauses. The most significant bit of the values shown in the tables is transmitted first.

A.8.1 Acknowledgement flag

The acknowledgement flag element shall be used to indicate whether or not U-OTAR KEY ASSOCIATE RESULT is expected after sending D-OTAR KEY ASSOCIATE DEMAND, or U-CK CHANGE RESULT after D-CK CHANGE DEMAND, or U-OTAR SCK RESULT after D-OTAR SCK PROVIDE, or U-OTAR GCK RESULT after D-OTAR GCK PROVIDE.

Table A.36: Acknowledgement flag element contents

Information element	Length	Value	Remark
Acknowledgement flag	1	0 ₂	No acknowledgement required
		1 ₂	Acknowledgement required

A.8.2 Address extension

The Address Extension Element is defined in EN 300 392-2 [2], clause 16.10.1.

A.8.3 Authentication challenge

The Authentication Challenge element shall contain the random seed and random challenge from the SwMI to the MS if authentication is to be used in the enable or disable procedure.

Table A.37: Authentication challenge element contents

Information sub element	Length	Type	Remark
Random challenge RAND1	80	1	
Random seed RS	80	1	

A.8.4 Authentication reject reason

Authentication reject reason indicates why a demand for authentication is rejected.

Table A.38: Authentication reject reason element contents

Information element	Length	Value	Remark
Authentication reject reason	3	000 ₂	Authentication not supported
		others	Reserved

A.8.5 Authentication result

Authentication result indicates the success or failure of an authentication. If the authentication fails, this element gives the reason for failure.

Table A.39: Authentication result element contents

Information element	Length	Value	Remark
Authentication Result [R1 or R2]	1	0 ₂	Authentication failed
		1 ₂	Authentication successful or no authentication currently in progress

A.8.6 Authentication sub-type

Authentication subtype identifies the specific PDU when PDU-type is 0000 (uplink) or 0001 (downlink).

Table A.40: Authentication sub-type element contents

Information element	Length	Value	Remark
Authentication sub-type (uplink)	2	00 ₂	U-AUTHENTICATION DEMAND
		01 ₂	U-AUTHENTICATION RESPONSE
		10 ₂	U-AUTHENTICATION RESULT
		11 ₂	U-AUTHENTICATION REJECT
Authentication sub-type (downlink)	2	00 ₂	D-AUTHENTICATION DEMAND
		01 ₂	D-AUTHENTICATION RESPONSE
		10 ₂	D-AUTHENTICATION RESULT
		11 ₂	D-AUTHENTICATION REJECT

A.8.7 CCK identifier

The CCK identifier (CCK-id) is the numerical value associated with a version number of a common cipher key.

Table A.41: CCK Identifier element contents

Information element	Length	Value	Remark
CCK Identifier	16	Any	

A.8.8 CCK information

The CCK information element is defined as below.

Table A.42: CCK information element contents

Information element	Length	Type	C/O/M	Remark
CCK identifier (CCK-id)	16	1	M	
Key type flag	1	1	M	0 = Current, 1 = Future
Sealed CCK (SCCK)	120	1	M	
CCK location area information	2-216	1	M	
Future key flag	1	1	M	Always false if key type flag = future
Sealed CCK (SCCK)	120		C	If future key flag = true

A.8.9 CCK Location area information

The CCK location area information element indicates how location area data is to be provided for any CCK.

Table A.43: CCK Location area information element contents

Information element	Length	Type	C/O/M	Remark
Type	2	1	M	00 = All location areas
				01 = List is provided
				10 = LA-id mask is provided
				11 = Range of LA-ids is provided
Location area list	18-214		C	If Type = 01
Location area bit mask	14		C	If Type = 10
Location area selector	14		C	If Type = 10
Location area range	28		C	If Type = 11
NOTE: The mask is logically ANDed with the LA-id. If the result is equal to the selector, then LA-id is valid for the CCK.				

A.8.10 CCK request flag

The CCK request flag is used to ask the SwMI to send the CCK in use in the location area to which the MS is attempting to register.

Table A.44: CCK request flag element contents

Information element	Length	Value	Remark
CCK request flag	1	0 ₂	No CCK requested
		1 ₂	CCK requested

A.8.11 Change of security class

The change of security class information element indicates to the MS that the current key change is, or is not, associated with a change in security class of the cell.

Table A.45: Change of security class element contents

Information element	Length	Value	Remark
Change of Security Class	2	00 ₂	No change of security class
		01 ₂	Transition to Security Class 1
		10 ₂	Transition to Security Class 2
		11 ₂	Transition to Security Class 3

A.8.12 Cipher parameters

The cipher parameters element is used to negotiate SCKN and KSG in class 2 cells, and KSG in class 3 cells. In addition, when registering for SC3 operation, the MS shall indicate its support for TM-SCK OTAR, SDMO and DM-SCK OTAR, and GCK encryption/OTAR.

Table A.46: Cipher parameters element contents

Information sub-element	Length	Type	C/O/M	Remark
KSG number	4	1	M	
Security class	1	1	M	Value = 0 for= Class 2 Value = 1 for= Class 3
SCK number	5		C	Provided if class 2
TM-SCK OTAR (see note)	1		C	Provided if class 3: Value = 0 if not supported Value = 1 if supported
SDMO and DM-SCK OTAR (see note)	1		C	Provided if class 3: Value = 0 if not supported Value = 1 if supported
GCK encryption/OTAR (see note)	1		C	Provided if class 3: Value = 0 if not supported Value = 1 if supported
Reserved	2		C	Provided if class 3, default value 0
NOTE: These fields (TM-SCK-OTAR, SDMO and DM-SCK-OTAR, GCK encryption/OTAR) only have meaning on the uplink. On the downlink these fields shall be set to value "0".				

A.8.13 CK provision flag

The CK provision flag is used to indicate that CK information is present in the PDU.

Table A.47: CK provision flag element contents

Information element	Length	Value	Remark
CK provision flag	1	0 ₂	No CK information provided (FALSE)
		1 ₂	CK information provided (TRUE)

A.8.14 CK provisioning information

The CK provisioning information element is used to indicate that either SCK information, CCK information or both are present in the PDU.

Table A.48: CK provisioning information flag element contents

Information sub-element	Length	Type	C/O/M	Remark
SCK provision flag	1	1	M	
SCK information	Varies		C	If SCK provision flag = TRUE
CCK provision flag	1	1	M	
CCK information	Varies		C	If CCK provision flag = TRUE

A.8.15 CK request flag

The CK request flag is used to ask the SwMI to send the CCK or SCK in use in the location area to which the MS is attempting to register. The type of key requested by the MS shall be inferred by the security class field in the ciphering parameters information element, contained within the same PDU as the CK request flag.

Table A.49: CK request flag element contents

Information element	Length	Value	Remark
CK request flag	1	0 ₂	No CK requested
		1 ₂	CK requested

A.8.16 Class Change flag

The Class Change flag is used to indicate that the class to the SwMI is to change.

Table A.50: Class Change flag element contents

Information element	Length	Value	Remark
Class Change flag	1	0 ₂	No Class change
		1 ₂	Class change

A.8.17 DCK forwarding result

The purpose of the DCK forwarding result element is to indicate if the SwMI was able to forward DCK to the requested new cell.

Table A.51: DCK forwarding result element contents

Information element	Length	Value	Remark
DCK Forwarding Result	1	0 ₂	DCK forwarding failure
		1 ₂	DCK forwarding successful

A.8.18 Disabling type

The purpose of the Disabling Type element shall be to indicate which of the disabling types (i.e. temporary or permanent) is requested.

Table A.52: Disabling Type element contents

Information element	Length	Value	Remark
Disabling Type	1	0 ₂	Temporary
		1 ₂	Permanent

A.8.19 Enable/Disable result

The purpose of the enable/disable result element shall be to indicate whether or not enabling or disabling was successful.

Table A.53: Enable/Disable result element contents

Information element	Length	Value	Remark
Enable/Disable result	3	000 ₂	Enable/disable successful
		001 ₂	Enable/disable failure, address mismatch
		010 ₂	Enable/disable failure, TEI mismatch
		011 ₂	Enable/disable failure, TEI and address mismatch
		100 ₂	Enable/disable failure, authentication is required
		101 ₂	Enable/disable failure, encryption is required
		110 ₂	Enable/disable failure, encryption and authentication are required
		111 ₂	Enable/disable failure, authentication not supported

A.8.20 Encryption mode

A.8.20.1 Class 1 cells

In a cell supporting only class 1 the following values and interpretations shall apply.

Table A.54: Encryption mode element in class 1 cell contents

Information element	Length	Value	Remark
Encryption mode element	2	00 ₂	PDU not encrypted
		Others	Reserved

A.8.20.2 Class 2 cells

In a class 2 cell the following values and interpretations shall apply.

Table A.55: Encryption mode element in class 2 cell contents

Information element	Length	Value	Remark
Encryption mode element	2	00 ₂	PDU not encrypted
		01 ₂	Reserved
		10 ₂	PDU encrypted, SCK-VN is even
		11 ₂	PDU encrypted, SCK-VN is odd

A.8.20.3 Class 3 cells

In a class 3 cell the following values and interpretations shall apply.

Table A.56: Encryption mode element in class 3 cell contents

Information element	Length	Value	Remark
Encryption mode element	2	00 ₂	PDU not encrypted
		01 ₂	Reserved
		10 ₂	PDU encrypted, CCK-id is even
		11 ₂	PDU encrypted, CCK-id is odd

A.8.21 Equipment disable

The purpose of the equipment disable element shall be to indicate whether the equipment is to be disabled.

Table A.57: Equipment disable element contents

Information element	Length	Value	Remark
Equipment disable	1	0 ₂	Equipment not to be disabled
		1 ₂	Equipment to be disabled

A.8.22 Equipment enable

The purpose of the Equipment enable element shall be to indicate whether the equipment is to be enabled.

Table A.58: Equipment enable element contents

Information element	Length	Value	Remark
Equipment enable	1	0 ₂	Equipment not to be enabled
		1 ₂	Equipment to be enabled

A.8.23 Equipment status

The purpose of the Equipment status element shall be to indicate the enabled or disabled state of the equipment.

Table A.59: Equipment status element contents

Information element	Length	Value	Remark
Equipment status	2	00 ₂	Equipment enabled
		01 ₂	Equipment temporarily disabled
		10 ₂	Equipment permanently disabled
		11 ₂	Reserved

A.8.23a Explicit response

The purpose of the explicit response element is to indicate whether the MS is required to acknowledge a key provision or key association explicitly, or conditionally on whether the transaction changes the MS state and provides a key, key version or key association that it did not already have.

Table A.59a: Explicit response element contents

Information element	Length	Value	Remark
Explicit response	1	0 ₂	Response to be sent only if state of MS is changed
		1 ₂	Response to be sent whether state changed or not

A.8.24 Frame number

Refer to EN 300 392-2 [2], clause 16.10.11.

A.8.25 Future key flag

The future key flag information element is defined in table A.60.

Table A.60: Future key flag information element contents

Information element	Length	Value	Remark
Future key flag	1	0 ₂	Indicates that no future key data is provided
		1 ₂	Indicates that future key data is provided

A.8.26 GCK data

The GCK data information element is defined in table A.61.

Table A.61: GCK data information element contents

Information element	Length	Type	C/O/M	Remark
GCK Number	16	1	M	
GCK Version number	16	1	M	

A.8.27 GCK key and identifier

The GCK key and identifier element is defined as in table A.62.

Table A.62: GCK key and identifier element contents

Information element	Length	Type	C/O/M	Remark
GCKN	16	1	M	
GCK version number	16	1	M	
Sealed GCK (SGCK)	120	1	M	

A.8.28 GCK Number (GCKN)

The GCKN is the identifier for a GCK used to associate it to one or more groups.

Table A.63: GCKN element contents

Information element	Length	Value	Remark
GCKN	16	any	

A.8.28a GCK Provision result

The GCK provision result indicates the result when provisioning a GCK using OTAR.

Table A.63a: GCK Provision Result

Information element	Length	Type	C/O/M	Remark
GCK data	32	1	M	
Provision result (GCK)	3	1	M	
Current GCK Version number	16		C	Defined as GCK-VN and sent when provision result has value incorrect key-VN
NOTE:	The address extension element is only present if the network code for which the provided GSSI relates is different to the serving network.			

A.8.28b GCK rejected

The GCK rejected element is defined in table A.63b.

Table A.63b: GCK rejected element contents

Information element	Length	Type	C/O/M	Remark
OTAR reject reason	3	1	M	
Group association	1	1	M	
GCKN	16		C	If Group association = GCKN
GSSI	24		C	If Group association = GSSI

A.8.29 GCK select number

The GCKN contained in OTAR key associate messages to indicate either which key should be associated with the signalled group(s); or whether no key should be associated and existing key disassociated.

Table A.64: GCK select number element contents

Information element	Length	Value	Remark
GCK select number	17	0 to $(2^{16} - 1)$	GCK number (GCKN) selected
		2^{16}	No GCKN selected (see note)
		$(2^{16} + 1)$ to $(2^{17} - 1)$	Reserved
NOTE: The value of "No GCKN selected" shall be used to disassociate a GCK from an address and return the association for that address to CCK, as described in clause 4.5.4.2.			

A.8.29a GCK Supported

The GCK Supported information element is found in the SYSINFO broadcast message and indicates to the MS whether or not GCKs are supported on the current cell.

Table A.64a: GCK Supported information element in SYSINFO

Information element	Length	Value	Remark
GCK Supported (see note)	1	0	GCK not supported on this cell
		1	GCK supported on this cell
NOTE: If the "Air interface encryption service" element in the BS service details element contained in the D-MLE SYSINFO PDU contains value 0, "Service is not available on this cell", then the value of this element has no meaning. This element is only valid if the security information element in SYSINFO, sub-element Security class 2 or 3 is set to "Security class 3 is supported on this cell".			

A.8.30 GCK Version Number (GCK-VN)

The GCK-VN shall be used in the GCK OTAR mechanism to uniquely identify a key by version number.

Table A.65: GCK-VN element contents

Information element	Length	Value	Remark
GCK-VN	16	any	

A.8.31 Group association

The group association element determines whether the provided GCK is for association with one specific group, or for association with all groups linked to a specific GCKN.

Table A.66: Group association element contents

Information element	Length	Value	Remark
Group association	1	0 ₂	Associated with GCKN
		1 ₂	Associated with specific GSSI

A.8.31a Group Identity Security Related Information

The group identity security related information indicates the association of cipher keys to group identity.

Table A.66a: Group Identity Security Related Information Element

Information element	Length	Type	C/O/M	Value	Remark
Number of groups	5	1	M		Indicates the number of GSSI corresponding to the given key association that follows.
GSSI	24	1	C		Shall be present as many times as indicated in the "Number of groups" value.
GCK Association	1	1	M	0 ₂ 1 ₂	GCK association information not provided GCK association information provided
GCK Select Number	17	1	C		Provided if <i>GCK Association</i> indicates "GCK Association Information Provided"; IE defined in the present document.
SCK Association	1	1	M	0 ₂ 1 ₂	SCK association information not provided SCK association information provided
SCK Subset Grouping Type	4	1	C		Provided if SCK Association indicates "SCK Association Information Provided"; IE defined in the present document.
SCK Subset Number	5	1	C		Provided if SCK Association indicates "SCK Association Information Provided"; IE defined in the present document.

A.8.32 GSKO Version Number (GSKO-VN)

The GSKO-VN shall be used in the group addressed OTAR mechanism to uniquely identify a key version number.

Table A.67: GSKO Version Number (GSKO-VN) element contents

Information element	Length	Value	Remark
GSKO-VN	16	any	

A.8.33 GSSI

See EN 300 392-1 [1], clause 7.

A.8.34 Hyperframe number

Refer to EN 300 392-2 [2].

A.8.35 Intent/confirm

The purpose of the Intent/confirm element shall be to indicate whether the enable or disable command is the first intent, always used with or without authentication, or the confirmation once successful authentication has been carried out.

Table A.68: Intent/confirm element contents

Information element	Length	Value	Remark
Intent/confirm	1	0 ₂	Intent
		1 ₂	Confirm

A.8.36 Void

A.8.37 Key association status

The key association status is sent by the MS to the SwMI to indicate the result of the key association Protocol exchange.

Table A.69: Key association result element contents

Information element	Length	Value	Remark
Key association status	3	000 ₂	Association carried out as requested
		001 ₂	Key not valid
		010 ₂	Address not valid
		011 ₂	Association rejected
		Others	Reserved

A.8.38 Key association type

Key association type identifies the type of key to be associated to a group.

Table A.70: Key association type information element contents

Information element	Length	Value	Remark
Key association type	1	0 ₂	SCK
		1 ₂	GCK

A.8.39 Key change type

Key change type identifies the type of key to be changed using the CK CHANGE protocol.

Table A.71: Key change type information element contents

Information element	Length	Value	Remark
Key change type	3	000 ₂	SCK
		001 ₂	CCK
		010 ₂	GCK
		011 ₂	Class 3 CCK and GCK activation
		100 ₂	All GCKs
		101 ₂	No cipher key
		110 ₂	Reserved
		111 ₂	Reserved

A.8.39a Key delete type

Key delete type identifies the type of key and organization of keys, where applicable, to be deleted by the D-OTAR Key Delete Demand PDU.

Table A.71a: Key delete type information element contents

Information element	Length	Value	Remark
Key delete type	3	000 ₂	Individual SCK(s)
		001 ₂	Members of a KAG
		010 ₂	SCK subset
		011 ₂	All SCKs
		100 ₂	Individual GCK(s)
		101 ₂	All GCKs
		110 ₂	GSKO
		111 ₂	Reserved

A.8.39b Key status type

Key status type identifies the type of key and organization of keys, where applicable, of which the SwMI is requesting status, or of which the MS is providing the status.

Table A.71b: Key status type information element contents

Information element	Length	Value	Remark
Key status type	3	000 ₂	Individual SCK(s)
		001 ₂	SCK subset
		010 ₂	All SCKs
		011 ₂	Individual GCK(s)
		100 ₂	All GCKs
		101 ₂	GSKO
		110 ₂	Reserved
		111 ₂	Reserved

A.8.40 Key type flag

Table A.72: Key type flag information element contents

Information element	Length	Value	Remark
Key type flag	1	0 ₂	Current
		1 ₂	Future

A.8.41 KSG-number

KSG number identifies the encryption algorithm in use.

Table A.73: KSG Number element contents

Information element	Length	Value	Remark
KSG Number	4	0000 ₂	TETRA Standard Algorithm, TEA1
		0001 ₂	TETRA Standard Algorithm, TEA2
		0010 ₂	TETRA Standard Algorithm, TEA3
		0011 ₂	TETRA Standard Algorithm, TEA4
		0100 ₂ to 0111 ₂	Reserved for future expansion
		1 ₂ xxx	Proprietary TETRA Algorithms

A.8.42 Location area

See EN 300 392-2 [2], clause 16.

A.8.43 Location area bit mask

The location area bit mask element provides an indication of location areas.

Table A.74: Location area bit mask element contents

Information element	Length	Value	Remark
Location area bit mask	14	any	Mask to be logically ANDed with LA-id for CCK distribution

A.8.44 Location area selector

The location area selector is used in conjunction with the location area bit mask element to provide an indication of location areas.

Table A.75: Location area selector element contents

Information element	Length	Value	Remark
Location area selector	14	any	Bit pattern for comparison with local LA-id

A.8.45 Location area list

The location area list element provides a list of location areas.

Table A.76: Location area list element contents

Information element	Length	Type	C/O/M	Remark
Number of location areas	4	1	M	
Location area	14		C	See note
NOTE:	The Location area element shall be repeated as many times as indicated by the Number of location areas element.			

A.8.46 Location area range

The location area range element provides a list of location areas that runs from Low Location Area value to High Location Area value.

Table A.77: Location area range element contents

Information element	Length	Value	Remark
Low Location Area value (LLAV)	14	0 to $2^{14}-1$	Lowest value of LA-id for which CCK is valid
High Location Area value (HLAV)	14	1 to $2^{14}-1$	Highest value of LA-id for which CCK is valid
NOTE: HLAV shall always be greater than LLAV.			

A.8.46a Max response timer value

The max response timer value element is used to set the maximum period over which an MS shall randomly choose a response time to a group addressed OTAR, key status or key association command.

Table A.77a: Max response timer value element contents

Information element	Length	Value	Remark
Max response timer value	16	0	Immediate response, for individually addressed transactions
		1 to $2^{16}-1$	Value in seconds from 1 to 65 535

A.8.47 Mobile country code

See EN 300 392-1 [1], clause 7.

A.8.48 Mobile network code

See EN 300 392-1 [1], clause 7.

A.8.49 Multiframe number

See EN 300 392-2 [2].

A.8.50 Mutual authentication flag

The Mutual Authentication Identifier is used to indicate whether or not mutual authentication elements are included in the PDU.

Table A.78: Mutual authentication flag element contents

Information element	Length	Value	Remark
Mutual authentication flag	1	0 ₂	Mutual authentication elements included = FALSE
		1 ₂	Mutual authentication elements included = TRUE

A.8.51 Network time

See EN 300 392-2 [2], clause 18.5.24.

A.8.52 Number of GCKs changed

The Number of GCKs changed element indicates how many group cipher keys were changed in the OTAR protocol.

Table A.79: Number of GCKs changed element contents

Information element	Length	Value	Remark
Number of GCKs changed	4	0000 ₂	No GCKs changed
		0001 ₂	1 GCK changed
		0010 ₂	2 GCKs changed
		0011 ₂	3 GCKs changed
		0100 ₂	4 GCKs changed
		Others	Etc. up to 15 GCKs changed

A.8.52a Number of GCKs deleted

The Number of GCKs deleted element indicates how many group cipher keys are to be or were deleted by the MS in the OTAR Key Delete protocol.

Table A.79a: Number of GCKs deleted element contents

Information element	Length	Value	Remark
Number of GCKs deleted	5	00000 ₂	No GCKs deleted
		00001 ₂ to 11111 ₂	1 to 31 GCKs deleted

A.8.52b Number of GCK status

The Number of GCK status element indicates how many group cipher keys' status information are being provided by the MS.

Table A.79b: Number of GCK status element contents

Information element	Length	Value	Remark
Number of GCK status	5	00000 ₂	MS has no GCKs, no GCK data element follows
		00001 ₂ to 11111 ₂	1 to 31 GCKs' data is provided

A.8.52c Number of GCKs provided

The Number of GCKs provided element indicates how many group cipher keys there are to follow in the PDU.

Table A.79c: Number of GCKs provided element contents

Information element	Length	Value	Remark
Number of GCKs provided	3	000 ₂	No GCKs provided
		001 ₂	1 GCK provided
		010 ₂	2 GCKs provided
		011 ₂	3 GCKs provided
		100 ₂	4 GCKs provided
		101 ₂	5 GCKs provided
		110 ₂	6 GCKs provided
		111 ₂	7 GCKs provided

A.8.52d Number of GCKs rejected

The Number of GCKs rejected element indicates how many group cipher keys are requested by the MS.

Table A.79d: Number of GCKs rejected element contents

Information element	Length	Value	Remark
Number of GCKs rejected	3	000 ₂	Reserved
		001 ₂	1 GCK rejected
		010 ₂	2 GCKs rejected
		011 ₂	3 GCKs rejected
		100 ₂	4 GCKs rejected
		101 ₂	5 GCKs rejected
		110 ₂	6 GCKs rejected
		111 ₂	7 GCKs rejected

A.8.52e Number of GCKs requested by GCKN

The Number of GCKs requested by GCKN element indicates how many group cipher keys are requested by the MS referenced by GCKN.

Table A.79e: Number of GCKs requested by GCKN element contents

Information element	Length	Value	Remark
Number of GCKs requested by GCKN	3	000 ₂	0 GCKs requested
		001 ₂	1 GCK requested
		010 ₂	2 GCKs requested
		011 ₂	3 GCKs requested
		100 ₂	4 GCKs requested
		101 ₂	5 GCKs requested
		110 ₂	6 GCKs requested
		111 ₂	7 GCKs requested

A.8.52f Number of GCKs requested by GSSI

The Number of GCKs requested by GSSI element indicates how many group cipher keys are requested by the MS referenced by GSSI.

Table A.79f: Number of GCKs requested by GSSI element contents

Information element	Length	Value	Remark
Number of GCKs requested by GSSI	3	000 ₂	0 GCKS requested
		001 ₂	1 GCK requested
		010 ₂	2 GCKs requested
		011 ₂	3 GCKs requested
		100 ₂	4 GCKs requested
		101 ₂	5 GCKs requested
		110 ₂	6 GCKs requested
		111 ₂	7 GCKs requested

A.8.53 Number of groups

The Number of groups element indicates how many GSSI elements there are to follow in the PDU.

Table A.80: Number of groups element contents

Information element	Length	Value	Remark
Number of groups	5	00000 ₂	Reserved.
		00001 ₂ to 11110 ₂	Number of GSSIs
		11111 ₂	Range of GSSIs (see notes 1 and 2)
NOTE 1: Range of GSSIs will be indicated by a lower and a higher value.			
NOTE 2: Value 11111 is not valid when used in U-OTAR Key Associate Status PDU and when used in Group Identity Security Related Information Element.			

A.8.53a Number of GSKO status

The Number of GSKO status element indicates how many group session keys for OTARs' status information are being provided by the MS.

Table A.80a: Number of GSKO status element contents

Information element	Length	Value	Remark
Number of GSKO status	2	00 ₂	MS has no GSKO, no GSKO data element follows
		01 ₂ to 11 ₂	1 to 3 GSKOs' data is provided

A.8.54 Number of location areas

The Number of location areas element indicates how many location area elements there are to follow in the PDU.

Table A.81: Number of location areas element contents

Information element	Length	Value	Remark
Number of location areas	4	0000 ₂	Reserved
		0001 ₂ to 1111 ₂	1 to 15 location areas

A.8.55 Number of SCKs changed

The Number of SCKs changed element indicates how many static cipher keys were changed in the OTAR protocol.

Table A.82: Number of SCKs changed element contents

Information element	Length	Value	Remark
Number of SCKs changed	4	0000 ₂	No SCKs changed
		0001 ₂	1 SCK changed
		0010 ₂	2 SCKs changed
		0011 ₂	3 SCKs changed
		0100 ₂	4 SCKs changed
		0101 ₂ to 1111 ₂	5 to 15 SCKs changed

A.8.55a Number of SCKs deleted

The Number of SCKs deleted element indicates how many static cipher keys are to be or were deleted by the MS in the OTAR Key Delete protocol.

Table A.82a: Number of SCKs deleted element contents

Information element	Length	Value	Remark
Number of SCKs deleted	5	00000 ₂	No SCKs deleted
		00001 ₂ to 11111 ₂	1 to 31 SCKs deleted

A.8.56 Number of SCKs provided

The Number of SCKs provided element indicates how many static cipher keys there are to follow in the PDU.

Table A.83: Number of SCKs provided element contents

Information element	Length	Value	Remark
Number of SCKs provided	3	000 ₂	No SCKs provided
		001 ₂	1 SCK provided
		010 ₂	2 SCKs provided
		011 ₂	3 SCKs provided
		100 ₂	4 SCKs provided
		101 ₂	5 SCKs provided
		110 ₂	6 SCKs provided
		111 ₂	7 SCKs provided

A.8.56a Number of SCKs rejected

The Number of SCKs rejected element indicates how many static cipher keys there are to follow in the PDU.

Table A.83a: Number of SCKs rejected element contents

Information element	Length	Value	Remark
Number of SCKs rejected	3	000 ₂	No SCKs rejected
		001 ₂	1 SCK rejected
		010 ₂	2 SCKs rejected
		011 ₂	3 SCKs rejected
		100 ₂	4 SCKs rejected
		101 ₂	5 SCKs rejected
		110 ₂	6 SCKs rejected
		111 ₂	7 SCKs rejected

A.8.57 Number of SCKs requested

The Number of SCKs requested element indicates how many static cipher keys are requested by the MS.

Table A.84: Number of SCKs requested element contents

Information element	Length	Value	Remark
Number of SCKs requested	3	000 ₂	Reserved
		001 ₂	1 SCK requested
		010 ₂	2 SCKs requested
		011 ₂	3 SCKs requested
		100 ₂	4 SCKs requested
		101 ₂	5 SCKs requested
		110 ₂	6 SCKs requested
		111 ₂	7 SCKs requested

A.8.57a Number of SCK status

The Number of SCK status element indicates how many static cipher keys' status information are being provided by the MS.

Table A.84a: Number of SCK status element contents

Information element	Length	Value	Remark
Number of SCK status	6	000000 ₂	MS has no SCKs, no SCK data element follows
		000001 ₂ to 100000 ₂	1 to 32 SCKs' data is provided
		100001 ₂ to 111111 ₂	Reserved

A.8.57b OTAR reject reason

The OTAR reject reason element indicates the reason that the SwMI does not supply the requested key.

Table A.84b: OTAR reject reason element contents

Information element	Length	Value	Remark
OTAR reject reason	3	000 ₂	Key not available
		001 ₂	Invalid key number
		010 ₂	Invalid address
		011 ₂	KSG number not supported
		Others	Reserved

A.8.57c OTAR retry interval

The OTAR retry interval information element indicates how many hyperframes the MS shall wait before retrying an OTAR Demand for SCK, GSKO or GCK.

Table A.84c: OTAR retry interval element contents

Information element	Length	Value	Remark
OTAR retry interval	3	000 ₂	Do not retry
		001 ₂	Wait 1 hyperframe
		010 ₂	Wait 2 hyperframes
		011 ₂	Wait 4 hyperframes
		100 ₂	Wait 8 hyperframes
		101 ₂	Wait 16 hyperframes
		110 ₂	Wait 32 hyperframes
		111 ₂	Wait 64 hyperframes

A.8.58 OTAR sub-type

The OTAR sub-type indicates whether the PDU is a demand or provide for CCK, SCK, GCK or GSKO keys or the result of a key transfer.

Table A.85: OTAR sub-type element contents

Information element	Length	Value	Remark
OTAR sub-type	4	0000 ₂	CCK Demand (uplink) or CCK Provide (downlink)
		0001 ₂	CCK Result (uplink) or CCK Reject (downlink)
		0010 ₂	SCK Demand (uplink) or SCK Provide (downlink)
		0011 ₂	SCK Result (uplink) or SCK Reject (downlink)
		0100 ₂	GCK Demand (uplink) or GCK Provide (downlink)
		0101 ₂	GCK Result (uplink) or GCK Reject (downlink)
		0110 ₂	Key associate Demand (downlink) or Key associate Status (uplink)
		0111 ₂	OTAR Prepare (Uplink) or OTAR NEWCELL (downlink)
		1000 ₂	GSKO Demand (uplink) or GSKO Provide (downlink)
		1001 ₂	GSKO Result (uplink) or GSKO Reject (downlink)
		1010 ₂	Key delete demand (downlink) or Key delete result (uplink)
		1011 ₂	Key status demand (downlink) or Key status response (uplink)
		1100 ₂	CMG GTSI provide (downlink) or CMG GTSI result (uplink)
		1101 ₂ to 1111 ₂	Reserved

A.8.59 PDU type

The PDU type indicates the MM PDU type for all the security PDUs including the authentication and OTAR PDUs. The PDU types in table A.86 are taken from the unused or security-reserved values of PDU type in the MM protocol. For more details, see EN 300 392-2 [2], clause 16.

Table A.86: PDU type element contents

Information element	Length	Value	Downlink Assignment	Uplink Assignment
PDU Type	4	0000 ₂	D-OTAR	U-AUTHENTICATION
		0001 ₂	D-AUTHENTICATION	
		0010 ₂	D-CK CHANGE DEMAND	
		0011 ₂	D-DISABLE	
		0100 ₂	D-ENABLE	U-CK CHANGE RESULT
		0101 ₂		U-OTAR
		1001 ₂		U-TEI PROVIDE
		1011 ₂		U-DISABLE STATUS

NOTE: Values not shown on both uplink and downlink are assigned to other PDU types, which are given in EN 300 392-2 [2], clause 16.10.39.

A.8.60 Proprietary

See EN 300 392-2 [2], table 120a.

A.8.61 Provision result

The provision result is sent by the MS to the SwMI to indicate whether or not the MS was able to decrypt the sealed key (CCK, SCK, GCK or GSKO).

Table A.87: Provision result element contents

Information element	Length	Value	Remark
Provision result	3	000 ₂	Sealed key accepted
		001 ₂	Sealed key failed to decrypt
		010 ₂	Incorrect key number (e.g. SCKN, GCKN)
		011 ₂	OTAR rejected
		100 ₂	Incorrect Key version number (e.g. SCK-VN, GCK-VN, CCK-id)
		101 ₂	Identified GSKO-VN not present
		110 ₂	KSG number not supported
		Others	Reserved

A.8.62 Random challenge

The random challenge is an 80-bit number used as the input to the authentication algorithm, from which a response is calculated.

Table A.88: Random challenge element contents

Information element	Length	Value	Remark
Random challenge [RAND1 or RAND2]	80	Any	

A.8.63 Random seed

The random seed is an 80-bit number used as the input to the session key generation algorithm, which is used in the authentication processes.

Table A.89: Random seed element contents

Information element	Length	Value	Remark
Random seed (RS)	80	Any	

A.8.64 Random seed for OTAR

The random seed for OTAR (RSO) is an 80-bit number used as the input to the session key for OTAR generation algorithm when sealing GCK, GSKO and SCK. Only one random seed is used per D-OTAR PDU, irrespective of the number of keys contained in the PDU. It is only provided from SwMI to MS.

Table A.90: Random seed element contents

Information element	Length	Value	Remark
Random seed for OTAR (RSO)	80	Any	

A.8.65 Void

Table A.91: Void

A.8.66 Response value

The response value is the value returned by the challenged party, calculated from the random challenge.

Table A.92: Response value element contents

Information element	Length	Value	Remark
Response Value (RES1 or RES2)	32	Any	

A.8.67 SCK data

The SCK data information element is defined in table A.93.

Table A.93: SCK data information element contents

Information element	Length	Type	C/O/M	Remark
SCK Number	5	1	M	
SCK Version number	16	1	M	

A.8.68 SCK information

The SCK information element is defined in table A.94.

Table A.94: SCK information element contents

Information element	Length	Type	C/O/M	Remark
Session key	1	1	M	Identifies if encrypted with group or individual encryption session key
Random seed for OTAR	80		C	Provided if session key for individual
GSKO-VN	16		C	Provided if session key for group
SCK number (SCKN)	5	1	M	
SCK version number (SCK-VN)	16	1	M	
Sealed SCK (SSCK)	120	1	M	
Future key flag	1	1	M	
SCK number (SCKN)	5		C	If future key flag = true
SCK version number (SCK-VN)	16		C	If future key flag = true
Sealed SCK (SSCK)	120		C	If future key flag = true

A.8.69 SCK key and identifier

The SCK key and identifier contains the sealed SCK which is identified by the SCK number.

Table A.95: SCK key and identifier element contents

Information element	Length	Type	C/O/M	Remark
SCKN	5	1	M	
SCK version number (SCK-VN)	16	1	M	
SCK use	1	1	M	If "0" Trunked Mode Operation If "1" Direct Mode Operation
Reserved	1	1	M	For future expansion
Sealed key (SSCK)	120	1	M	

A.8.70 SCK Number (SCKN)

The SCK number is a five-bit value associated with an SCK. Where multiple SCKs are transferred, this element is repeated with each SCK number related to the SCKs being transferred.

Table A.96: SCK number element contents

Information element	Length	Value	Remark
SCK number	5	00000 ₂	SCK number 1
		00001 ₂	SCK number 2
		etc.	SCK numbers in turn
		11101 ₂	SCK number 30
		11110 ₂	Class 2: SCK number 31; Class 3: fallback SCK number 31
		11111 ₂	Class 2: SCK number 32; Class 3: fallback SCK number 32

A.8.71 SCK number and result

The SCK number and result contains the result of the SCK key transfer for the key identified by the SCK number.

Table A.97: SCK number and result element contents

Information element	Length	Type	C/O/M	Remark
SCK number (SCKN)	5	1	M	
Provision result (SCK)	3	1	M	
Current SCK Version number	16		C	Defined as SCK-VN and sent when provision result has value incorrect key-VN

A.8.72 SCK provision flag

The SCK provision flag is used to indicate that SCK information is present in the PDU.

Table A.98: SCK provision flag element contents

Information element	Length	Value	Remark
SCK provision flag	1	0 ₂	No SCK information provided (FALSE)
		1 ₂	SCK information provided (TRUE)

A.8.72a Void

Table A.99: Void

A.8.72b SCK rejected

The SCK rejected element is defined as in table A.99a.

Table A.99a: SCK rejected element contents

Information element	Length	Type	C/O/M	Remark
OTAR reject reason	3	1	M	
SCK number (SCKN)	5	1	M	

A.8.73 SCK select number

The SCK select number is contained in OTAR key associate messages to indicate either which key should be associated with the signalled group(s); or whether no key should be associated and any existing key disassociated. It is also used to indicate which keys have been selected in result PDUs. Where SCKs have been grouped into subsets, association with a single SCK shall automatically associate the group or groups with the other corresponding SCK members of other subsets. The SCKN selected shall be taken from the first subset only, i.e. the subset with SCKN = 1 as its lowest value.

Table A.100: SCK select number element contents

Information element	Length	Value	Remark
SCK select	6	000000 ₂ to 011111 ₂	SCK number (SCKN) selected
		100000 ₂	No SCKN selected
		100001 ₂	SCKN dissociated
		100010 ₂ to 111111 ₂	Reserved

A.8.73a SCK subset grouping type

The SCK subset grouping type element is contained in OTAR key associate messages where the SCK set is split into 2 or more subsets. It allows the MS to associate multiple associated SCKs in different SCK subsets with the same group or groups.

Table A.100a: SCK subset grouping type element contents

Information element	Length	Value	Remark
SCK subset grouping type	4	0000 ₂	SCKs grouped into 1 subset of 30 keys
		0001 ₂	SCKs grouped into 2 subsets of 15 keys
		0010 ₂	SCKs grouped into 3 subsets of 10 keys
		0011 ₂	SCKs grouped into 4 subsets of 7 keys
		0100 ₂	SCKs grouped into 5 subsets of 6 keys
		0101 ₂	SCKs grouped into 6 subsets of 5 keys
		0110 ₂	SCKs grouped into 7 subsets of 4 keys
		0111 ₂	SCKs grouped into 10 subsets of 3 keys
		1000 ₂	SCKs grouped into 15 subsets of 2 keys
		1001 ₂	SCKs grouped into 30 subsets of 1 key
		1010 ₂	SCK grouping not valid, used to indicate a mismatch in key deletion or subset activation conditions
1011 ₂ to 1111 ₂	Reserved		

A.8.73b SCK subset number

The SCK subset number element is contained in CK Change Demand messages where the SCK set is split into 2 or more subsets and a complete subset is to be made active. It indicates the number of the subset that is to be activated.

Table A.100b: SCK subset number element contents

Information element	Length	Value	Remark
SCK subset number	5	00000 ₂	Mismatched number, used to indicate a mismatch in grouping when responding to a key status or delete demand
		00001 ₂ to 11110 ₂	Subset 1 to 30, value indicates number of subset
		11111 ₂	Reserved
NOTE 1: SCK subset number element value shall not be greater than the highest number of subsets permitted by the grouping signified by the SCK subset group number element.			
NOTE 2: SCK subset number = 1 corresponds to subset where lowest SCKN = 1.			

A.8.74 SCK use

The SCK use information element indicates if the SCK being provided is intended for use in Trunked Mode Operation or for use in Direct Mode Operation.

Table A.101: SCK version number element contents

Information element	Length	Value	Remark
SCK use	1	0 ₂	Trunked Mode Operation
		1 ₂	Direct Mode Operation

A.8.75 SCK version number

The SCK Version Number (SCK-VN) is the numerical value associated with a version number of a key being transferred in an OTAR SCK transaction. Multiple SCK-VNs shall be sent where multiple keys are transferred, one SCK-VN per key.

Table A.102: SCK version number element contents

Information element	Length	Value	Remark
SCK version number	16	Any	

A.8.76 Sealed Key (Sealed CCK, Sealed SCK, Sealed GCK, Sealed GSKO)

The Sealed Key is the key transferred by an OTAR transaction, in a protected (encrypted) manner.

Table A.103: Sealed Key element contents

Information element	Length	Value	Remark
Sealed Key	120	Any	

A.8.77 Security information element

The Security information element is found in the SYSINFO broadcast message and indicates to the MS the current security capabilities of the cell.

Table A.104: Security information element in SYSINFO

Information element	Length	C/O/M	Value	Remark
Authentication (see note 4)	1	M	0 ₂	Authentication not required on this cell
			1 ₂	Authentication required on this cell
Security Class 1 (see note 1)	1	M	0 ₂	Security Class 1 MS not supported on this cell
			1 ₂	Security Class 1 MS supported on this cell
Security Class 2 or 3 (see note 1)	1	M	0 ₂	Security Class 2 MS supported on this cell
			1 ₂	Security Class 3 MS supported on this cell
SCKN (see notes 1 and 2)	5	C		If Security Class 2 MS supported on this cell
DCK retrieval during initial Cell selection (see notes 1 and 3)	1	C	0 ₂	Service not supported
			1 ₂	Service supported
DCK retrieval during cell Re-selection (see notes 1 and 3)	1	C	0 ₂	Service not supported
			1 ₂	Service supported
Linked GCK crypto-periods (see notes 3 and 5)	1	C	0 ₂	Service not supported
			1 ₂	Service supported
Short GCK-VN (see notes 3 and 6)	2	C		Represents the 2 least significant bits of the GCK-VN associated with the linked GCKs.
NOTE 1: If the "Air interface encryption service" element in the BS service details element contained in the D-MLE SYSINFO PDU contains value 0, "Service is not available on this cell", then the value of this element has no meaning.				
NOTE 2: If Security Class 2 MS supported on this cell.				
NOTE 3: If Security Class 3 MS supported on this cell.				
NOTE 4: An MS that does not support authentication should not select a cell that broadcasts "authentication required"				
NOTE 5: If the "GCK Supported" information element in SYSINFO indicates "GCK not supported on this cell" then the value of this element has no meaning.				
NOTE 6: If the "Linked GCK crypto-periods" information element indicates "Service not supported" then the value of this element has no meaning.				

A.8.77a Security related information element

The security related information element is included in the D-FACILITY (ASSIGN) PDU for SS-DGNA to indicate the security associations of the GSSI.

Table A.104a: Security Related Information Element

Information element	Length	Type	C/O/M	Value	Remark
GCK Association	1	1	M	0 ₂ 1 ₂	GCK association information not provided GCK association information provided
GCK Select Number	17	1	C		Provided if <i>GCK Association</i> indicates "GCK Association Information Provided"; IE defined in the present document
SCK Association	1	1	M	0 ₂ 1 ₂	SCK association information not provided SCK association information provided
SCK Subset Grouping Type	4	1	C		Provided if <i>SCK Association</i> indicates "SCK Association Information Provided"; IE defined in the present document
SCK Subset Number	5	1	C		Provided if <i>SCK Association</i> indicates "SCK Association Information Provided"; IE defined in the present document

A.8.78 Session key

The Session key element indicates whether a key has been sealed using a Group Session Key for OTAR known to members of a group, or sealed with a Session Key for OTAR (KSO) which is individually generated by an MS.

Table A.105: Session key element contents

Information element	Length	Value	Remark
Session key	1	0 ₂	Sealed key has been generated using individually generated session key KSO for MS
		1 ₂	Sealed key has been generated using Group Session Key for OTAR known to group of MSs

A.8.79 Slot Number

See EN 300 392-2 [2], clause 7.

A.8.80 SSI

See EN 300 392-1 [1], clause 7.

A.8.81 Subscription disable

The purpose of the Subscription disable element shall be to indicate whether the subscription is to be disabled.

Table A.106: Subscription disable element contents

Information element	Length	Value	Remark
Subscription disable	1	0 ₂	Subscription not to be disabled
		1 ₂	Subscription to be disabled

A.8.82 Subscription enable

The purpose of the Subscription enable element shall be to indicate whether the subscription is to be enabled.

Table A.107: Subscription enable element contents

Information element	Length	Value	Remark
Subscription enable	1	0 ₂	Subscription not to be enabled
		1 ₂	Subscription to be enabled

A.8.83 Subscription status

The purpose of the Subscription status element shall be to indicate the enabled or disabled state of the subscription.

Table A.108: Subscription status element contents

Information element	Length	Value	Remark
Subscription status	2	00 ₂	Subscription enabled
		01 ₂	Subscription temporarily disabled
		10 ₂	Subscription permanently disabled
		11 ₂	Reserved

A.8.84 TEI

This is the terminal equipment identifier of the MS. For a full definition see EN 300 392-1 [1], clause 7. The definition given here expands that given in EN 300 392-1 [1], clause 7 for encoding of TEI for transmission over the radio interface.

Table A.109: TEI contents

Information element	Length	Value	Remark
Terminal equipment identifier digit #1	4	Any	
Terminal equipment identifier digit #2	4	Any	
Terminal equipment identifier digit #3	4	Any	
Terminal equipment identifier digit #4	4	Any	
Terminal equipment identifier digit #5	4	Any	
Terminal equipment identifier digit #6	4	Any	
Terminal equipment identifier digit #7	4	Any	
Terminal equipment identifier digit #8	4	Any	
Terminal equipment identifier digit #9	4	Any	
Terminal equipment identifier digit #10	4	Any	
Terminal equipment identifier digit #11	4	Any	
Terminal equipment identifier digit #12	4	Any	
Terminal equipment identifier digit #13	4	Any	
Terminal equipment identifier digit #14	4	Any	
Terminal equipment identifier digit #15	4	Any	

A.8.85 TEI request flag

This bit indicates whether the MS should supply the TEI.

Table A.110: TEI request flag contents

Information element	Length	Value	Remark
TEI request flag	1	0 ₂	Do not supply TEI
		1 ₂	Supply TEI

A.8.85a Timeshare cell and AI encryption information

Table A.110a: Timeshare cell and AI encryption information element

Information element	Type	Length	Value	Remark
Discontinuous mode/AI encryption information	M	2	00 ₂	AI encryption information
			Others	Defined in EN 300 392-2 [2], table 255
Authentication flag (see note 2)	M	1	0 ₂	Authentication not required on this cell
			1 ₂	Authentication required on this cell
Class 1	M	1	0 ₂	MS of security class 1 not supported on this cell
			1 ₂	MS of security class 1 supported on this cell
Security class 2 or 3 (see notes 1 and 3)	M	1	0 ₂	MS of security class 2 supported on this cell
			1 ₂	MS of security class 3 supported on this cell
NOTE 1: Security class 2 and security class 3 are mutually exclusive.				
NOTE 2: If the "Air interface encryption service" element in the BS service details element contained in the D-MLE SYSINFO PDU and in D-NWRK BROADCAST PDUs contains value 0, "Service is not available on this cell", then the value of this element has no meaning.				
NOTE 3: This field is ignored if BS Service Details indicate no support of AI encryption.				

A.8.86 Time type

The time type element indicates what form time is expressed in the PDU.

Table A.111: Time type information element contents

Information element	Length	Value	Remark
Time type	2	00 ₂	Absolute IV
		01 ₂	Network time
		10 ₂	Immediate, first slot of first frame of next multiframe
		11 ₂	Currently in use

A.8.87 Type 3 element identifier

The type 3-element identifier indicates the MM type 3 elements to be used in the MM PDUs for authentication and OTAR purposes. The type 3 element identifiers in table A.112 are identified in the present document only and are taken from the reserved values of type 3 element identifier defined in the MM protocol.

For more details, see EN 300 392-2 [2], clause 16.

Table A.112: Type 3 element identifier element contents

Information element	Length	Value	Remarks
Type 3 element identifier	4	1001 ₂	Authentication uplink
		1010 ₂	Authentication downlink

Annex B (normative): Boundary conditions for the cryptographic algorithms and procedures

In the following the symbol $|XYZ|$ shall be used to denote the length of the parameter XYZ. If the length of a parameter can vary, $|XYZ|$ denotes the range between the shortest and the longest possible values for XYZ.

TA11: Shall be used to compute KS from K and RS. The algorithm shall have the following properties:

- Input 1: Bit string of length $|K|$;
- Input 2: Bit string of length $|RS|$;
- Output: Bit string of length $|KS|$.

The algorithm should be designed such that it is difficult to infer any information about Input 1 from the knowledge of Input 2 and the Output (even if the details of the algorithm are known).

TA21: shall be used to compute the KS' from K and RS. The algorithm shall have the following properties:

- Input 1: Bit string of length $|K|$;
- Input 2: Bit string of length $|RS|$;
- Output: Bit string of length $|KS'|$.

The algorithm should be designed such that it is difficult to infer any information about Input 1 from the knowledge of Input 2 and the Output (even if the details of the algorithm are known).

TA12: shall be used to compute (X)RES1 as well as DCK1 from KS and RAND1. The algorithm shall have the following properties:

- Input 1: Bit string of length $|KS|$;
- Input 2: Bit string of length $|RAND1|$;
- Output 1: Bit string of length $|(X)RES1|$;
- Output 2: Bit string of length $|DCK1|$.

The algorithm should be designed such that it is difficult to infer any information about Input 1 or Output 2 from the knowledge of Input 2 and Output 1 (even if the details of the algorithm are known).

TA22: shall be used to compute (X)RES2 as well as DCK2 from KS' and RAND2. The algorithm shall have the following properties:

- Input 1: Bit string of length $|KS'|$;
- Input 2: Bit string of length $|RAND2|$;
- Output 1: Bit string of length $|(X)RES2|$;
- Output 2: Bit string of length $|DCK2|$.

The algorithm should be designed such that it is difficult to infer any information about Input 1 or Output 2 from the knowledge of Input 2 and Output 1 (even if the details of the algorithm are known).

TA31: shall be used to compute SCCK from CCK, CCK-id and DCK. The algorithm shall have the following properties:

- Input 1: Bit string of length |CCK|;
- Input 2: Bit string of length |CCK-id|;
- Input 3: Bit string of length |DCK|;
- Output: Bit string of length |SCCK|.

The algorithm should be designed such that it is difficult to infer any information about Input 1 from the knowledge of Input 2 and the Output, provided that Input 3 is unknown (even if the details of the algorithms are known).

TA32: shall be used to compute CCK from SCCK, CCK-id and DCK. The algorithm shall have the following properties:

- Input 1: Bit string of length |SCCK|;
- Input 2: Bit string of length |DCK|;
- Input 3: Bit string of length |CCK-id|;
- Output 1: Bit string of length |CCK|;
- Output 2: Boolean.

The algorithm should be designed such that it is difficult to find for a fixed Input 2 a value for Input 1 and Input 3 that results in Output 2 assuming the value "FALSE", provided that Input 2 is unknown (even if the details of the algorithms are known). Moreover, it shall be difficult to derive (parts of) Input 2 from the observation of various matching values of other inputs and outputs (known plain text attack).

TA41: shall be used to compute KSO from K and RSO. The algorithm shall have the following properties:

- Input 1: Bit string of length |K|;
- Input 2: Bit string of length |RSO|;
- Output 1: Bit string of length |KSO|.

The algorithm should be designed such that it is difficult to infer any information about Input 1 from knowledge of input 2 and the output (even if details of the algorithm are known).

TA51: shall be used to compute SSCK from SCK, SCKN, SCK-VN, and KSO. The algorithm shall have the following properties:

- Input 1: Bit string of length |SCK|;
- Input 2: Bit string of length |SCK-VN|;
- Input 3: Bit string of length |KSO|;
- Input 4: Bit string of length |SCKN|;
- Output: Bit string of length |SSCK|.

The algorithms should be designed such that it is difficult to infer any information about Input 1 or Input 4 from the knowledge of Input 2 and the Output, provided that Input 3 is unknown (even if the details of the algorithm are known).

TA52: shall be used to compute SCK and SCKN from SSCK, SCK-VN and KSO. The algorithm shall have the following properties:

- Input 1: Bit string of length |SSCK|;
- Input 2: Bit string of length |KSO|;
- Input 3: Bit string of length |SCK-VN|;
- Output 1: Bit string of length |SCK|;
- Output 2: Boolean;
- Output 3: Bit string of length |SCKN|.

The algorithm should be designed such that it is difficult to find for a fixed Input 2 values for Input 1 and Input 3 that result in Output 2 assuming the value FALSE, provided that Input 2 is unknown (even if the details of the algorithm are known). Moreover, it shall be difficult to derive (parts of) Input 2 from the observation of various matching values of other inputs and outputs (known plain text attack).

TA61: shall be used to compute xESI from xSSI and either SCK or CCK. The algorithm shall have the following properties:

- Input 1: Bit string of length |CCK|;
- Input 2: Bit string of length |SSI|;
- Output 1: Bit string of length |ESI|.

The algorithm should be designed such that it is difficult to infer any knowledge of Input 1 from observation of various matching values of other input 2s and outputs. Further it should be difficult to infer any knowledge of Input 2 from observation of various matching values of other input 2s and outputs. Moreover, for a fixed input 1 different values of Input 2 shall always give different values of the output.

TA71: shall be used to compute MGCK from GCK and CCK. The algorithm shall have the following properties:

- Input 1: Bit string of length |GCK|;
- Input 2: Bit string of length |CCK|;
- Output 1: Bit string of length |MGCK|.

The algorithm should be designed such that it is difficult to infer any information about Input 1 from knowledge of input 2 and the output (even if details of the algorithm are known), and also designed such that it is difficult to infer any information about Input 2 from knowledge of input 1 and the output (even if details of the algorithm are known).

TA81: shall be used to compute SGCK from GCK, GCKN, GCK-VN and KSO. The algorithm shall have the following properties:

- Input 1: Bit string of length |GCK|;
- Input 2: Bit string of length |GCK-VN|;
- Input 3: Bit string of length |KSO|;
- Input 4: Bit string of length |GCKN|;
- Output: Bit string of length |SGCK|.

The algorithm should be designed such that it is difficult to infer any information about Input 1 from the knowledge of Input 2, Input 4, and the Output, provided that Input 3 is unknown (even if the details of the algorithms are known).

TA82: shall be used to compute GCK and GCKN from SGCK, GCK-VN, and KSO. The algorithm shall have the following properties:

- Input 1: Bit string of length |SGCK|;
- Input 2: Bit string of length |KSO|;
- Input 3: Bit string of length |GCK-VN|;
- Output 1: Bit string of length |GCK|;
- Output 2: Boolean;
- Output 3: Bit string of length |GCKN|.

The algorithm should be designed such that it is difficult to find for a fixed Input 2 values for Input 1 and Input 3 that result in Output 2 assuming the value "FALSE", provided that Input 2 is unknown (even if the details of the algorithms are known). Moreover, it shall be difficult to derive (parts of) Input 2 from the observation of various matching values of other inputs and outputs (known plain text attack).

TA91: shall be used to compute SGSKO from GSKO, GSKO-VN and KSO. The algorithm shall have the following properties:

- Input 1: Bit string of length |GSKO|;
- Input 2: Bit string of length |GSKO-VN|;
- Input 3: Bit string of length |KSO|;
- Output: Bit string of length |SGSKO|.

The algorithm should be designed such that it is difficult to infer any information about Input 1 from the knowledge of Input 2 and the Output, provided that Input 3 is unknown (even if the details of the algorithms are known).

TA92: shall be used to compute GSKO from SGSKO, GSKO-VN, and KSO. The algorithm shall have the following properties:

- Input 1: Bit string of length |SGSKO|;
- Input 2: Bit string of length |KSO|;
- Input 3: Bit string of length |GSKO-VN|;
- Output 1: Bit string of length |GSKO|;
- Output 2: Boolean.

The algorithm should be designed such that it is difficult to find for a fixed Input 1 values for Input 3 that result in Output 2 assuming the value "FALSE", provided that Input 2 is unknown (even if the details of the algorithms are known). Moreover, it shall be difficult to derive (parts of) Input 2 from the observation of various matching values of other inputs and outputs (known plain text attack).

TA101: shall be used to compute KSv from KS, GCK0 and MNI.

- Input 1: Bit string of length |KS|;
- Input 2: Bit string of length |GCK0|;
- Input 3: Bit string of length |MNI|;
- Output: Bit string of length |KSv|.

The algorithm shall be designed so that the Output is dependent on every bit of all Inputs. The algorithm shall be designed such that Inputs 1 and 2 shall be difficult to infer from knowledge of Input 3 and the Output.

The following algorithms, TB1, TB2 and TB3 may be used to generate K locally to an MS but do not directly alter the air interface.

TB1: shall be used to compute K from AC. The algorithm shall have the following properties:

- Input: Bit string of length |AC|;
- Output: Bit string of length |K|.

The algorithm should be designed such that the Output is dependent on every bit of the Input.

TB2: shall be used to compute K from UAK. The algorithm shall have the following properties:

- Input: Bit string of length |UAK|;
- Output: Bit string of length |K|.

The algorithm should be designed such that the Output is dependent on every bit of the Input.

TB3: shall be used to compute K from UAK and AC. The algorithm shall have the following properties:

- Input 1: Bit string of length |AC|;
- Input 2: Bit string of length |UAK|;
- Output: Bit string of length |K|.

The algorithm should be designed such that the Output is dependent on every bit of both Inputs.

TB4: shall be used to compute DCK from DCK1 and DCK2. The algorithm shall have the following properties:

- Input 1: Bit string of length |DCK1|;
- Input 2: Bit string of length |DCK2|;
- Output: Bit string of length |DCK|.

The algorithm should be designed such that the Output is dependent on every bit of both Inputs.

TB5: shall be used to compute ECK from CK, CC, CN (see EN 300 392-2 [2], clause 21.5) and LA. The algorithm shall have the following properties:

- Input 1: Bit string of length |CK|;
- Input 2: Bit string of length |LA|;
- Input 3: Bit string of length |CN|;
- Input 4: Bit string of length |CC|;
- Output: Bit string of length |ECK|.

The algorithm should be designed such that the Output is dependent on every bit of all Inputs.

TB6: Reserved for DMO Security (EN 300 396-6 [5]).

TB7: shall be used to compute EGSKO from GSKO. The algorithm shall have the following properties:

- Input: Bit string of length |GSKO|;
- Output: Bit string of length |EGSKO|.

The algorithm should be designed such that the Output is dependent on every bit of the Input.

B.1 Dimensioning of the cryptographic parameters

Table B.1 shows the lengths of the cryptographic parameters given in annex B.

Table B.1: Dimensioning of cryptographic parameters

Abbreviation	No. of bits
AC	16 to 32
CC	6
CCK	80
CCK-id	16
CK	80
CN	12
DCK	80
DCK1	80
DCK2	80
ECK	80
EGSKO	128
ESI	24
GCK	80
GCKN	16
GCKO	80
GCK-VN	16
GSKO	96
GSKO-VN	16
K	128
KS	128
KS'	128
KSO	128
KS _v	128
LA	14
MF	1
MGCK	80
MNI	24
PIN	16 to 32
RAND1	80
RAND2	80
RES1	32
RES2	32
RS	80
RSO	80
SCCK	120
SCK	80
SCKN	5
SCK-VN	16
SGCK	120
SGSKO	120
SSCK	120
SSI	24
UAK	128
XRES1	32
XRES2	32

B.2 Summary of the cryptographic processes

A summary of the authentication mechanisms explained in the previous clauses is given in figures B.1 and B.2 . Only the paths where keys are generated by an algorithm are shown.

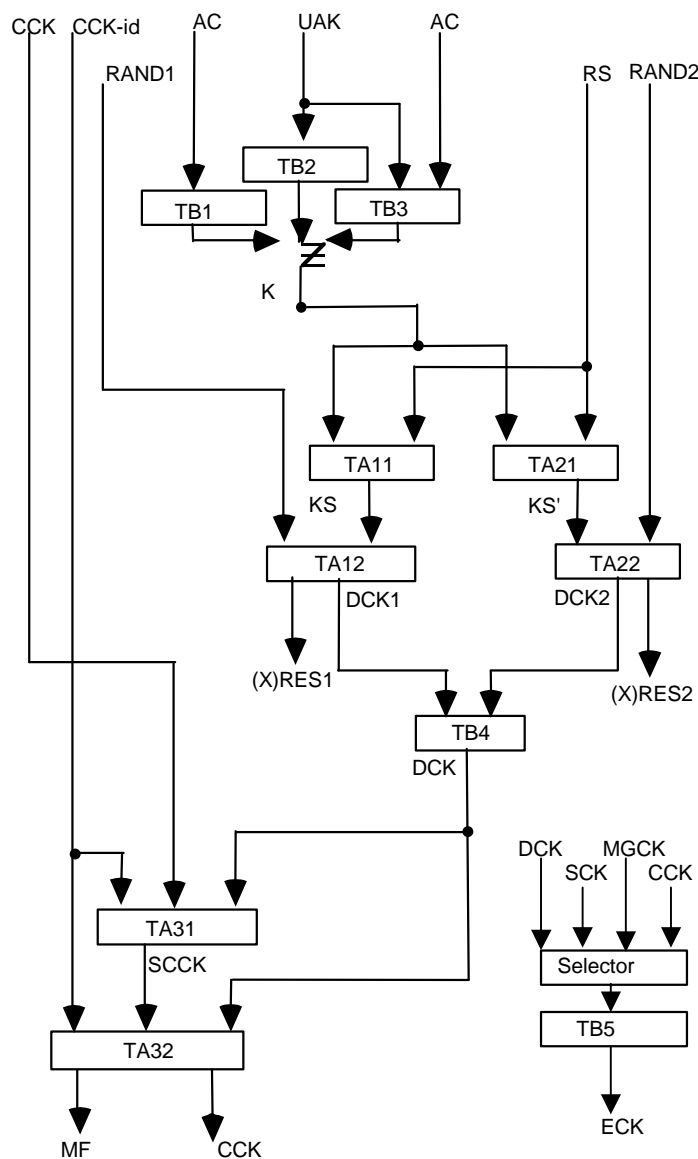

NOTE: Algorithms TB1, TB2 and TB3 are shown for information and may be used in deriving K within an MS.

Figure B.1: Overview of air interface authentication and key management (sheet 1 of 2)

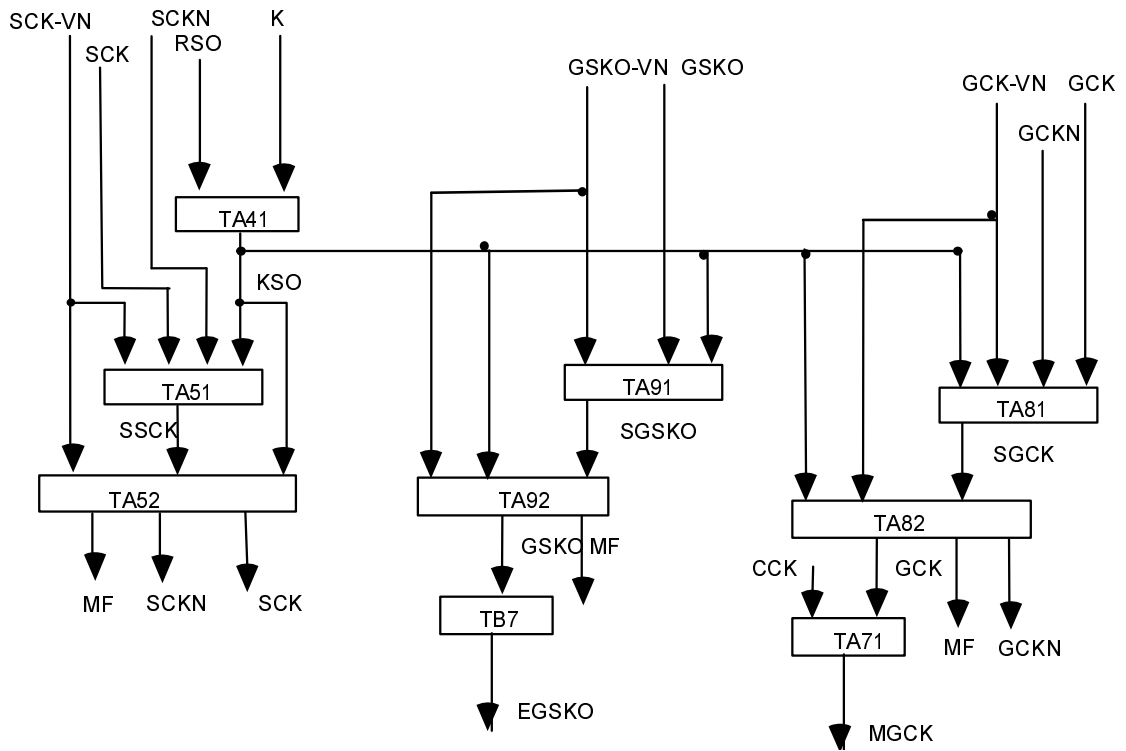

Figure B.2: Overview of air interface authentication and key management (sheet 2 of 2)

Annex C (normative): Timers

C.1 T354, authorization protocol timer

The value of T354 shall be 30 seconds.

C.2 T371, Delay timer for group addressed delivery of SCK and GCK

T371 is a timer with a value in seconds randomized to fall within the range 1 and the SwMI-supplied "max response timer value" (which can be given a value from 1 to 65 535, i.e. 18,2 hours).

C.3 T372, Key forwarding timer

The value of T372 shall be 5 seconds.

C.4 T355, disable control timer

The value of T355 shall be at least 30 seconds.

Annex D (informative): Bibliography

- ETSI ETS 300 395-3: "Terrestrial Trunked Radio (TETRA); Speech codec for full-rate traffic channel; Part 3: Specific operating features".
- ETSI ES 202 109: "Terrestrial Trunked Radio (TETRA); Security; Synchronization mechanism for end-to-end encryption".
- ETSI ETS 300 395-1: "Terrestrial Trunked Radio (TETRA); Speech codec for full-rate traffic channel; Part 1: General description of speech functions".
- ETSI SR 001 262: "ETSI drafting rules".

Annex E (informative): Change request history

The following CRs have been incorporated in the present document.

CR	Date	Version	Short description	Status
103	17-3-05	V2.2.1	Definition of security related information and group identity security related information element	WG6 approved (updated)
113	9-3-06	V3.0.0	Encryption of $\pi/8$ D8PSK and QAM logical channels	WG6 approved
124	11-1-07	V3.0.0	Inclusion of timer between disable intent and disable confirm PDUs	WG6 approved
125	4-10-06	V3.0.0	TS 300 392-7 v2.4.0 incorporates PDU elements whose use is not described in protocol section: this CR provides text to correct this.	WG6 approved
126	29-10-06	V2.4.1	Editorial changes recommended by ETSI editHelp on review of TS 100 392-7v2.4.1	WG6 approved
128	12-12-06	V2.4.1	Definitions for DCK Forwarding and DCK Retrieval	WG6 approved
129	14-12-06	V2.4.1	Clarification on behaviour on deletion of CMG GSSI	WG6 approved
131	1-3-07	V3.0.0	Boundary conditions for TA101	WG6 approved
132	12-4-07	V3.0.0	Removal of spurious value for GCK Select Number	WG6 approved
133	14-5-07	V3.0.0	Clarification of status of CK after disable	WG6 approved
134	5-6-07	V3.0.0	Correction of figure 39 in clause 5.1	WG6 approved
137	22-6-07	V3.0.0	Removal of mandates from scope clause	WG6 approved
138	20-7-07	V3.0.0	Explicit mention of $\pi/8$ -D8PSK modulation	WG6 approved
139	26-11-07	V3.0.2	Correction of the D-OTAR and U-OTAR PDUs	WG6 approved

History

Document history		
Edition 1	December 1996	Publication as ETS 300 392-7 (Historical)
V2.1.1	December 2000	Publication as TS 100 392-7
V2.1.1	February 2001	Publication
V2.2.1	September 2004	Publication
V2.3.1	June 2006	Publication (Withdrawn)
V2.4.1	October 2006	Publication as TS 100 392-7
V3.0.2	July 2007	Public Enquiry PE 20071102: 2007-07-04 to 2007-11-02
V3.0.3	April 2008	Vote V 20080627: 2008-04-28 to 2008-06-27