

Final draft **ETSI EN 300 392-3-2** V1.4.0 (2010-04)

---

*European Standard (Telecommunications series)*

**Terrestrial Trunked Radio (TETRA);  
Voice plus Data (V+D);  
Part 3: Interworking at the Inter-System Interface (ISI);  
Sub-part 2: Additional Network Feature  
Individual Call (ANF-ISIIC)**

---



---

Reference

REN/TETRA-03193

---

Keywords

air interface, TETRA, V+D

**ETSI**

650 Route des Lucioles  
F-06921 Sophia Antipolis Cedex - FRANCE

Tel.: +33 4 92 94 42 00 Fax: +33 4 93 65 47 16

Siret N° 348 623 562 00017 - NAF 742 C  
Association à but non lucratif enregistrée à la  
Sous-Préfecture de Grasse (06) N° 7803/88

---

**Important notice**

Individual copies of the present document can be downloaded from:

<http://www.etsi.org>

The present document may be made available in more than one electronic version or in print. In any case of existing or perceived difference in contents between such versions, the reference version is the Portable Document Format (PDF). In case of dispute, the reference shall be the printing on ETSI printers of the PDF version kept on a specific network drive within ETSI Secretariat.

Users of the present document should be aware that the document may be subject to revision or change of status. Information on the current status of this and other ETSI documents is available at

<http://portal.etsi.org/tb/status/status.asp>

If you find errors in the present document, please send your comment to one of the following services:

[http://portal.etsi.org/chaicor/ETSI\\_support.asp](http://portal.etsi.org/chaicor/ETSI_support.asp)

---

**Copyright Notification**

No part may be reproduced except as authorized by written permission.  
The copyright and the foregoing restriction extend to reproduction in all media.

© European Telecommunications Standards Institute 2010.  
All rights reserved.

**DECT™**, **PLUGTESTS™**, **UMTS™**, **TIPHON™**, the TIPHON logo and the ETSI logo are Trade Marks of ETSI registered for the benefit of its Members.

**3GPP™** is a Trade Mark of ETSI registered for the benefit of its Members and of the 3GPP Organizational Partners.

**LTE™** is a Trade Mark of ETSI currently being registered

for the benefit of its Members and of the 3GPP Organizational Partners.

**GSM®** and the GSM logo are Trade Marks registered and owned by the GSM Association.

# Contents

Intellectual Property Rights .....	8
Foreword.....	8
1 Scope .....	10
2 References .....	11
2.1 Normative references .....	11
2.2 Informative references.....	12
3 Definitions and abbreviations.....	12
3.1 Definitions.....	12
3.2 Abbreviations .....	13
4 ANF-ISIIC stage 1 specification .....	14
4.1 Description .....	14
4.1.1 General description .....	14
4.1.2 Qualifications on applicability to telecommunication services.....	14
4.2 Procedures .....	15
4.2.1 Provision/withdrawal.....	15
4.2.2 Normal procedures.....	15
4.2.2.1 Activation/deactivation/registration/interrogation .....	15
4.2.2.2 Invocation and operation.....	15
4.2.2.2.1 Call routing .....	15
4.2.2.2.2 Control of call time-out timers .....	16
4.2.2.2.3 Transmission control .....	16
4.2.2.2.3a Setup modification.....	16
4.2.2.2.4 Call modification.....	16
4.2.2.2.5 Call restoration after migration.....	16
4.2.2.2.6 Call clearing .....	17
4.2.2.2.7 Interaction between ANF-ISIICs.....	17
4.2.2.2.8 Radio traffic channel resource queuing and allocation policies .....	18
4.2.3 Exceptional procedures.....	18
4.2.3.1 Activation/deactivation/registration/interrogation .....	18
4.2.3.2 Invocation and operation.....	18
4.3 Interactions with other TETRA supplementary services and ANFs.....	19
4.3.1 Calling Line Identification Presentation (SS-CLIP) .....	19
4.3.2 Connected Line identification Presentation (SS-COLP).....	19
4.3.3 Calling/connected Line Identification Restriction (SS-CLIR).....	19
4.3.4 Call Report (SS-CR) .....	19
4.3.5 Talking Party Identification (SS-TPI).....	19
4.3.6 Call Forwarding Unconditional (SS-CFU) .....	19
4.3.7 Call Forwarding on Busy (SS-CFB).....	21
4.3.8 Call Forwarding on No Reply (SS-CFNRy).....	22
4.3.9 Call Forwarding on Not Reachable (SS-CFNRC).....	22
4.3.10 List Search Call (SS-LSC).....	23
4.3.11 Call Authorized by Dispatcher (SS-CAD).....	23
4.3.12 Short Number Addressing (SS-SNA) .....	24
4.3.13 Area Selection (SS-AS) .....	24
4.3.14 Access Priority (SS-AP) .....	24
4.3.15 Priority Call (SS-PC) .....	25
4.3.16 Call Waiting (SS-CW).....	25
4.3.17 Call Hold (SS-HOLD).....	25
4.3.18 Call Completion to Busy Subscriber (SS-CCBS).....	25
4.3.19 Late Entry (SS-LE) .....	25
4.3.20 Void.....	25
4.3.21 Pre-emptive Priority Call (SS-PPC).....	25
4.3.22 Include Call (SS-IC) .....	26
4.3.23 Advice of Charge (SS-AoC) .....	26

4.3.24	Barring of Outgoing Calls (SS-BOC) .....	26
4.3.25	Barring of Incoming Calls (SS-BIC) .....	26
4.3.26	Discreet Listening (SS-DL) .....	27
4.3.27	Ambience Listening (SS-AL) .....	27
4.3.28	Dynamic Group Number Assignment (SS-DGNA).....	27
4.3.29	Call Completion on No Reply (SS-CCNR) .....	27
4.3.30	Call Retention (SS-CRT) .....	27
4.3.31	Additional Network Feature - Inter System Interface Group Call (ANF-ISIGC).....	28
4.3.32	Additional Network Feature - Inter System Interface Short Data Service (ANF-ISISDS).....	28
4.3.33	Additional Network Feature - Inter System Interface Mobility Management (ANF-ISIMM) .....	28
4.3.34	Additional Network Feature - Inter System Interface Supplementary service (ANF-ISISS) .....	28
4.4	Interworking considerations .....	28
4.5	Static description of ANF-ISIIC using attributes .....	30
4.6	Overall SDL .....	32
5	ANF-ISIIC stage 2 specification .....	37
5.1	Functional model.....	37
5.1.1	Functional model description.....	37
5.1.2	Description of functional entities.....	38
5.1.2.1	SwMI A individual call control application functional entity, FE1 .....	38
5.1.2.2	ISI individual call originating functional entity, FE2.....	39
5.1.2.3	ISI individual outgoing call route determining functional entity, FE3.....	39
5.1.2.4	ISI individual call migration handling functional entity, FE4.....	39
5.1.2.5	ISI information provision functional entity, FE5 .....	40
5.1.2.6	ISI individual call migrated called user routeing functional entity, FE6.....	40
5.1.2.7	ISI individual call terminating functional entity, FE7 .....	40
5.1.2.8	Terminating SwMI call control functional entity, FE8 .....	41
5.1.3	Relationship of functional model to basic call functional model.....	41
5.2	Information flow .....	42
5.2.1	Examples of information flow sequences .....	42
5.2.1.1	Successful call set-up when the called user is registered in SwMI B and uses on/off hook signalling .....	43
5.2.1.2	Successful call set-up when the called user is registered in SwMI B and uses direct set-up signalling .....	45
5.2.1.3	ANF-ISIIC set-up to a called user having migrated from SwMI B, using forward switching .....	46
5.2.1.4	ANF-ISIIC set-up to a called user having migrated from SwMI B, using re-routeing .....	46
5.2.1.5	Loop avoidance in case of intra-TETRA call.....	49
5.2.1.6	Unsuccessful ANF-ISIIC call set-up.....	50
5.2.1.7	Transmission control.....	52
5.2.1.8	Call modify .....	53
5.2.1.9	Call restoration after migration .....	54
5.2.1.10	Call clearing .....	56
5.2.1.11	Radio traffic channel resource queuing and allocation.....	56
5.2.2	Definition of information flows .....	57
5.2.2.1	CALL RESTORE .....	57
5.2.2.2	CALL RESTORE PREPARE .....	58
5.2.2.3	CHARACTERISTIC CHANGE .....	59
5.2.2.4	COMPLETE.....	59
5.2.2.5	INFORM 1 .....	60
5.2.2.6	INFORM 2 .....	60
5.2.2.7	INFORM 3 .....	60
5.2.2.8	MIGRATION.....	61
5.2.2.9	MODIFY .....	61
5.2.2.10	RELEASE .....	62
5.2.2.11	SETUP .....	62
5.2.2.12	SETUP PROLONGATION .....	63
5.2.2.13	TROMBONE .....	64
5.2.2.14	TX-CEASED .....	64
5.2.2.14.1	TX-CEASED 1 .....	64
5.2.2.14.2	TX-CEASED 2 .....	64
5.2.2.15	TX-CONTINUE 1.....	65
5.2.2.16	TX-CONTINUE 2.....	65

5.2.2.17	TX-DEMAND .....	65
5.2.2.18	TX-GRANTED .....	66
5.2.2.19	TX-INTERRUPT .....	66
5.2.2.20	TX-WAIT.....	66
5.2.3	Relationship of information flows to basic call information flows.....	66
5.3	Functional entity actions .....	67
5.4	Allocation of functional entities to physical equipment/SwMIs.....	67
6	ANF-ISIIC stage 3 specification .....	69
6.1	ANF-ISIIC description .....	69
6.2	ANF-ISIIC operational requirements .....	69
6.2.1	Requirements on the originating SwMI.....	69
6.2.2	Requirements on the terminating SwMI .....	70
6.2.3	Requirements on a called SwMI when it is different from the terminating SwMI .....	70
6.2.4	Requirements on a routeing SwMI .....	71
6.2.5	Requirements on a SwMI with PSTN/ISDN/PISN incoming gateway .....	71
6.2.6	Requirements on a SwMI with PSTN/ISDN/PISN outgoing gateways.....	72
6.3	ANF-ISIIC coding requirements .....	73
6.3.1	TETRA PDUs.....	73
6.3.1.1	TETRA PDU giving complementary information in the PSS1 SETUP message sent by the originating or the incoming gateway SwMI.....	74
6.3.1.2	TETRA PDU giving complementary information in a PSS1 PROGRESS message .....	77
6.3.1.3	TETRA message sent by the called SwMI in a PSS1 FACILITY message when it is not the terminating SwMI because of migration or SS-CF invocation .....	77
6.3.1.4	TETRA message sent by the originating SwMI in a PSS1 FACILITY message to request forward switching .....	79
6.3.1.5	TETRA PDU giving complementary information in the PSS1 ALERTING message .....	80
6.3.1.6	TETRA PDU giving complementary information in the PSS1 CONNECT message.....	80
6.3.1.7	TETRA information sent by the terminating SwMI in PSS1 FACILITY messages before the PSS1 ALERTING or CONNECT message.....	82
6.3.1.8	TETRA information sent by the terminating SwMI in a PSS1 FACILITY message during call establishment after the PSS1 ALERTING or CONNECT message.....	83
6.3.1.9	TETRA information sent by the originating SwMI in a PSS1 FACILITY message before the call has been established .....	83
6.3.1.10	TETRA CONNECT ACKNOWLEDGE sent by the originating SwMI in a PSS1 FACILITY message .....	83
6.3.1.11	Other TETRA messages possibly sent by the originating SwMI in PSS1 FACILITY messages .....	83
6.3.1.12	TETRA messages possibly sent by either the originating or the terminating SwMI in a PSS1 FACILITY message .....	85
6.3.1.13	TETRA messages possibly sent by the terminating SwMI in PSS1 FACILITY messages .....	86
6.3.1.14	TETRA PDUs giving complementary information in PSS1 messages to restore the call after the calling or the connected user has migrated in a new SwMI .....	87
6.3.1.14.1	Case where no connection between the old SwMI and the new SwMI already exists or has been identified .....	88
6.3.1.14.2	Cases where no new connection is needed between the old SwMI and the new SwMI.....	89
6.3.1.15	TETRA PDUs giving complementary information in PSS1 DISCONNECT messages.....	92
6.3.1.16	TETRA PDU giving complementary information in a PSS1 RELEASE message .....	93
6.3.1.17	TETRA PDUs giving complementary information in a PSS1 RELEASE COMPLETE message .....	93
6.3.1.18	TETRA PDUs specific for interaction with supplementary service protocol sent to the originating SwMI in a PSS1 FACILITY message .....	93
6.3.1.19	TETRA PDUs sent towards the Called or Visited SwMI in a PSS1 FACILITY after the PSS1 call has been connected.....	94
6.3.1.20	TETRA PDUs sent towards the Called or Originating SwMI in a PSS1 FACILITY after the PSS1 call has connected.....	96
6.3.2	TETRA PDU information element coding .....	97
6.3.2.1	Specific ISI definition of some information elements already defined for air interface messages .....	97
6.3.2.1.1	Basic service information .....	97
6.3.2.1.2	Call status .....	97
6.3.2.1.3	Call time-out, set-up phase .....	97
6.3.2.1.4	Disconnect cause information element.....	98
6.3.2.1.5	PDU type .....	99
6.3.2.2	New information elements used at the ISI .....	100

6.3.2.2.1	Call diverted to a dispatcher .....	100
6.3.2.2.2	Call has been forward switched.....	100
6.3.2.2.3	Call identified as fleet call.....	100
6.3.2.2.4	Called/forwarded-to external subscriber number.....	100
6.3.2.2.5	Called/forwarded-to party extension .....	100
6.3.2.2.6	Called/forwarded-to party SSI.....	100
6.3.2.2.7	Called/forwarded-to party fleet number SSI.....	100
6.3.2.2.8	Called/forwarded-to user having migrated .....	101
6.3.2.2.9	Calling external subscriber number.....	101
6.3.2.2.10	Calling external subscriber number parameters.....	101
6.3.2.2.11	Calling party fleet number SSI.....	101
6.3.2.2.12	Calling party presentation indicator.....	101
6.3.2.2.13	Cause for PDU addressed to originating SwMI.....	102
6.3.2.2.14	Connected external subscriber number.....	102
6.3.2.2.15	Connected external subscriber number parameters .....	102
6.3.2.2.16	Connected party presentation indicator .....	102
6.3.2.2.17	Connected party extension.....	102
6.3.2.2.18	Connected party SSI.....	102
6.3.2.2.19	Connected party fleet number SSI.....	103
6.3.2.2.20	Controlling SwMI.....	103
6.3.2.2.21	Incoming call barring status .....	103
6.3.2.2.22	Forwarded-to external subscriber number .....	103
6.3.2.2.23	Forwarded-to user extension .....	103
6.3.2.2.24	Forwarded-to user SSI.....	103
6.3.2.2.25	Last Forwarding SwMI MNI.....	103
6.3.2.2.26	Modify accepted .....	103
6.3.2.2.27	Modify request .....	104
6.3.2.2.28	MSISDN present as external subscriber number.....	104
6.3.2.2.29	New SwMI MNI.....	104
6.3.2.2.30	Number of digits in called/forwarded-to external subscriber number .....	104
6.3.2.2.31	Number of digits in calling external subscriber number.....	104
6.3.2.2.32	Number of digits in connected external subscriber number .....	104
6.3.2.2.33	Number of digits in forwarded-to external subscriber number.....	105
6.3.2.2.34	Number of digits in visited/forwarded-to SwMI PISN number.....	105
6.3.2.2.35	Originating SwMI MNI.....	105
6.3.2.2.36	Other end SwMI MNI .....	105
6.3.2.2.37	Override SS-CAD invocation.....	105
6.3.2.2.38	PDU addressed to originating SwMI.....	105
6.3.2.2.39	Possible ISI trombone or loop connection detected.....	105
6.3.2.2.40	Restoring party extension .....	106
6.3.2.2.41	Restoring party SSI.....	106
6.3.2.2.41a	Radio traffic channel release permission.....	106
6.3.2.2.41b	Radio traffic channel release signalling supported .....	107
6.3.2.2.41c	Resource indicator .....	107
6.3.2.2.42	Routeing method choice .....	107
6.3.2.2.43	Routeing method response.....	108
6.3.2.2.44	Security level at calling user air interface.....	108
6.3.2.2.44a	Setup resource allocation.....	108
6.3.2.2.45	Speech service requested/chosen/used .....	108
6.3.2.2.46	Speech services supported.....	109
6.3.2.2.47	SS-CF invocation counter.....	109
6.3.2.2.48	SS-CF invoked .....	109
6.3.2.2.49	SS-CLIR invoked for other party .....	109
6.3.2.2.50	Terminating SwMI MNI.....	109
6.3.2.2.51	Visited/forwarded-to SwMI MNI.....	109
6.3.2.2.52	Visited/forwarded-to SwMI PISN number .....	109
6.3.3	PSS1 facility information element.....	110
6.4	ANF-ISIIC state definitions .....	111
6.5	ANF-ISIIC signalling procedures.....	111
6.5.1	Call establishment.....	111
6.5.1.1	Call request, information channel selection, PISN called number sending and call proceeding.....	111
6.5.1.2	Called user migration .....	111

6.5.1.2.1	Called user having migrated in SwMI C different from SwMI A .....	112
6.5.1.2.2	Called user having migrated in SwMI C coinciding with SwMI A .....	115
6.5.1.3	Call characteristics and set-up time negotiation by the terminating SwMI .....	115
6.5.1.4	Call confirmation indication and call connected by the terminating SwMI .....	116
6.5.1.5	Failure of call establishment .....	117
6.5.2	Call maintenance procedures .....	118
6.5.2.1	Transmission control procedures .....	118
6.5.2.2	Call modification and/or continuation .....	118
6.5.2.3	Call restoration .....	118
6.5.2.3.1	General call restoration procedure .....	118
6.5.2.3.2	Specific call restoration procedure in a SwMI already on the path of the call .....	120
6.5.3	DTMF procedures .....	123
6.5.4	ANF-ISIIC clearing .....	123
6.5.5	Call collisions .....	124
6.6	ANF-ISIIC impact of interworking with ISDN/PISN/PSTN .....	125
6.7	Protocol interactions between ANF-ISIIC and supplementary services and other ANFs .....	125
6.7.1	Interaction with SS-CLIR .....	125
6.7.2	Interactions with SS-CF .....	126
6.7.2.1	Interaction with SS-CF at call establishment .....	126
6.7.2.2	Specific interaction with SS-CFNry at call establishment .....	126
6.7.2.3	Interaction with SS-CF at call restoration .....	126
6.7.3	Interaction with SS-CAD .....	127
6.7.3.1	Invocation of a specific ANF-ISIIC .....	127
6.7.3.2	Interception of an already invoked ANF-ISIIC .....	127
6.7.3.3	Call authorization by a distant dispatcher .....	127
6.7.3.4	Completion of call establishment .....	127
6.7.3.4.1	Call not diverted to dispatcher .....	127
6.7.3.4.2	Call diverted to dispatcher .....	128
6.7.4	Interactions with SS-PC, SS-PPC and SS-CRT .....	128
6.7.5	Interaction with SS-CW .....	129
6.7.6	Interaction with SS-HOLD .....	129
6.7.7	Interaction with SS-CCBS and SS-CCNR .....	129
6.7.8	Interaction with SS-BIC .....	129
6.7.9	Interactions with SS-AoC .....	129
6.7.10	Area Selection (SS-AS) and selected area number .....	130
6.7.11	Interactions with other supplementary services .....	130
6.8	ANF-ISIIC parameter values (timers) .....	130
<b>Annex A (informative):</b>	<b>Static description of the TETRA individual call bearer service, using attributes .....</b>	<b>131</b>
<b>Annex B (informative):</b>	<b>Definition of the ISI ROSE operation .....</b>	<b>132</b>
<b>Annex C (informative):</b>	<b>Interactions of SS-CFU with ANF-ISIIC .....</b>	<b>133</b>
C.1	Possible SS-CFU activation .....	133
C.2	Invocation and operation .....	133
C.2.1	Called user home SwMI being SwMI A .....	133
C.2.2	Called user home SwMI being SwMI B .....	133
C.2.2.1	Forwarded-to user with home SwMI being SwMI B, being registered in its home SwMI .....	134
C.2.2.2	Forwarded-to user with home SwMI being SwMI B, having migrated .....	135
C.2.2.3	Forwarded-to user with home SwMI different from SwMI B, being registered in its home SwMI .....	135
C.2.2.4	Forwarded-to user with home SwMI different from SwMI B, having migrated .....	135
<b>Annex D (informative):</b>	<b>Change Requests .....</b>	<b>138</b>
History	.....	139

---

## Intellectual Property Rights

IPRs essential or potentially essential to the present document may have been declared to ETSI. The information pertaining to these essential IPRs, if any, is publicly available for **ETSI members and non-members**, and can be found in ETSI SR 000 314: *"Intellectual Property Rights (IPRs); Essential, or potentially Essential, IPRs notified to ETSI in respect of ETSI standards"*, which is available from the ETSI Secretariat. Latest updates are available on the ETSI Web server (<http://webapp.etsi.org/IPR/home.asp>).

Pursuant to the ETSI IPR Policy, no investigation, including IPR searches, has been carried out by ETSI. No guarantee can be given as to the existence of other IPRs not referenced in ETSI SR 000 314 (or the updates on the ETSI Web server) which are, or may be, or may become, essential to the present document.

---

## Foreword

This European Standard (Telecommunications series) has been produced by ETSI Technical Committee Terrestrial Trunked Radio (TETRA), and is now submitted for the ETSI standards One-step Approval Procedure.

The present document is part 3, sub-part 2 of a multi-part deliverable covering Voice plus Data (V+D), as identified below:

EN 300 392-1: "General network design";

EN 300 392-2: "Air Interface (AI)";

**EN 300 392-3: "Interworking at the Inter-System Interface (ISI)";**

EN 300 392-3-1: "General design";

**EN 300 392-3-2: "Additional Network Feature Individual Call (ANF-ISIIC)";**

EN 300 392-3-3: "Additional Network Feature Group Call (ANF-ISIGC)";

EN 300 392-3-4: "Additional Network Feature Short Data Service (ANF-ISISDS)";

EN 300 392-3-5: "Additional Network Feature for Mobility Management (ANF-ISIMM)";

TS 100 392-3-6: "Speech format implementation for circuit mode transmission";

TS 100 392-3-7: "Speech Format Implementation for Packet Mode Transmission";

TS 100 392-3-8: "Generic Speech Format Implementation";

ETS 300 392-4: "Gateways basic operation";

EN 300 392-5: "Peripheral Equipment Interface (PEI)";

EN 300 392-7: "Security";

EN 300 392-9: "General requirements for supplementary services";

EN 300 392-10: "Supplementary services stage 1";

EN 300 392-11: "Supplementary services stage 2";

EN 300 392-12: "Supplementary services stage 3";

ETS 300 392-13: "SDL model of the Air Interface (AI)";

ETS 300 392-14: "Protocol Implementation Conformance Statement (PICS) proforma specification";

TS 100 392-15: "TETRA frequency bands, duplex spacings and channel numbering";

TS 100 392-16: "Network Performance Metrics";



TR 100 392-17: "TETRA V+D and DMO specifications";

TS 100 392-18: "Air interface optimized applications".

NOTE: Part 3, sub-parts 6 and 7 (Speech format implementation), part 4, sub-part 3 (Data networks gateway), part 10, sub-part 15 (Transfer of control), part 13 (SDL) and part 14 (PICS) of this multi-part deliverable are in status "historical" and are not maintained.

<b>Proposed national transposition dates</b>	
Date of latest announcement of this EN (doa):	3 months after ETSI publication
Date of latest publication of new National Standard or endorsement of this EN (dop/e):	6 months after doa
Date of withdrawal of any conflicting National Standard (dow):	6 months after doa

---

# 1 Scope

The present document defines the Terrestrial Trunked Radio (TETRA) system supporting Voice plus Data (V+D). It specifies:

- general design aspects (e.g. reference points, numbering and addressing, or protocol architecture);
- the system bearer and mobility management services, and the corresponding air interface protocols;
- the interworking between TETRA networks;
- the interworking of TETRA networks with other networks, via gateways;
- the peripheral equipment interface on the mobile station;
- the Line Station (LS) interface with TETRA networks;
- the security protocols and mechanisms applicable to TETRA networks and to TETRA terminal equipment;
- the supplementary services applicable to the basic TETRA tele- or bearer services.

The TETRA V+D interworking - basic operation part defines the interworking between TETRA networks over the corresponding interface: the Inter-System Interface (ISI). It comprises the following subparts:

- ISI general design;
- Additional Network Feature - ISI Individual Call (ANF-ISIIC);
- Additional Network Feature - ISI Group Call (ANF-ISIGC);
- Additional Network Feature - ISI Short Data service (ANF-ISISDS);
- Additional Network Feature - ISI Mobility Management (ANF-ISIMM);
- 8 kbit/s encoding of user information at the ISI.

The present document is the ANF-ISIIC sub-part.

ANF-ISIIC enables calls to be set-up by a user registered in one TETRA network to another user registered in another TETRA network, operating at the ISI of both SwMIs. It also supports call restoration when a user has migrated to another TETRA network during an established call. Additionally, ANF-ISIIC allows TETRA signalling information to be passed from a TETRA SwMI to another TETRA SwMI supporting the TETRA individual call procedures as defined in clauses 11 and 14 of EN 300 392-2 [1].

Like all other Additional Network Feature (ANF) specifications, those of ANF-ISIIC are produced in three stages, according to the method described in ITU-T Recommendation I.130 [i.5]. The present document contains the stage 1 and 2 descriptions of ANF-ISIIC, and its partial stage 3 description. The stage 1 description specifies the ANF as seen by its users, which are essentially the individual call control entities in both TETRA networks. The stage 2 description identifies the functional entities involved in the ANF and the information flows between them. And the partial stage 3 description of ANF-ISIIC specifies its protocol.

**NOTE:** According to ITU-T Recommendation I.130 [i.5], the stage 3 description of a bearer or tele-service addresses the network implementation aspects. Consequently, it comprises two steps: the specifications of all protocols at the various reference points involved in any of the service procedures (notably the service operation) are the first step of the stage 3 description, and the specifications of the functions of the corresponding network entities are its second step.

The latter have not been provided since they can be derived from the specification of the functional entity actions in the stage 2 description.

The present document applies to TETRA networks which support inter-TETRA individual calls. More specifically, it applies to their Circuit Mode Control Entities (CMCE), as defined in clause 14.2 of EN 300 392-2 [1], and to their ANF-ISIIC entities defined in the stage 2 description.

## 2 References

References are either specific (identified by date of publication and/or edition number or version number) or non-specific.

- For a specific reference, subsequent revisions do not apply.
- Non-specific reference may be made only to a complete document or a part thereof and only in the following cases:
  - if it is accepted that it will be possible to use all future changes of the referenced document for the purposes of the referring document;
  - for informative references.

Referenced documents which are not found to be publicly available in the expected location might be found at <http://docbox.etsi.org/Reference>.

NOTE: While any hyperlinks included in this clause were valid at the time of publication ETSI cannot guarantee their long term validity.

### 2.1 Normative references

The following referenced documents are indispensable for the application of the present document. For dated references, only the edition cited applies. For non-specific references, the latest edition of the referenced document (including any amendments) applies.

- |      |  |
|------|--|
| [1]  | ETSI EN 300 392-2: "Terrestrial Trunked Radio (TETRA); Voice plus Data (V+D); Part 2: Air Interface (AI)".   |
| [2]  | ETSI EN 300 392-3-1: "Terrestrial Trunked Radio (TETRA); Voice plus Data (V+D); Part 3: Interworking at the Inter-System Interface (ISI); Sub-part 1: General design".   |
| [3]  | ETSI EN 300 392-3-3: "Terrestrial Trunked Radio (TETRA); Voice plus Data (V+D); Part 3: Interworking at the Inter-System Interface (ISI); Sub-part 3: Additional Network Feature Group Call (ANF-ISIGC)".  |
| [4]  | ETSI EN 300 392-3-5: "Terrestrial Trunked Radio (TETRA); Voice plus Data (V+D); Part 3: Interworking at the Inter-System Interface (ISI); Sub-part 5: Additional Network Feature for Mobility Management (ANF-ISIMM)".   |
| [5]  | Void.  |
| [6]  | ETSI EN 300 392-9: "Terrestrial Trunked Radio (TETRA); Voice plus Data (V+D); Part 9: General requirements for supplementary services".  |
| [7]  | ETSI EN 300 172: "Private Integrated Services Network (PISN); Inter-exchange signalling protocol; Circuit-mode basic services [ISO/IEC 11572 (2000) modified]".  |
| [8]  | ETSI EN 300 392-12-4: "Terrestrial Trunked Radio (TETRA); Voice plus Data (V+D); Part 12: Supplementary services stage 3; Sub-part 4: Call Forwarding (CF)".   |
| [9]  | ISO/IEC 11572: "Information technology - Telecommunications and information exchange between systems - Private Integrated Services Network - Circuit mode bearer services - Inter-exchange signalling procedures and protocol".  |
| [10] | ISO/IEC 11574: "Information technology - Telecommunications and information exchange between systems - Private Integrated Services Network - Circuit mode 64 kbit/s bearer services - Service description, functional capabilities and information flows".               |
| [11] | ISO/IEC 11582: "Information technology - Telecommunications and information exchange between systems - Private Integrated Services Network - Generic functional protocol for the support of supplementary services - Inter-exchange signalling procedures and protocol". |

- [12] ITU-T Recommendation I.460: "Multiplexing, rate adaption and support of existing interfaces".
- [13] ETSI EN 300 392-12-8: "Terrestrial Trunked Radio (TETRA); Voice plus Data (V+D); Part 12: Supplementary services stage 3; Sub-part 8: Area Selection (AS)".

## 2.2 Informative references

The following referenced documents are not essential to the use of the present document but they assist the user with regard to a particular subject area. For non-specific references, the latest version of the referenced document (including any amendments) applies.

- [i.1] ETSI EN 300 392-7: "Terrestrial Trunked Radio (TETRA); Voice plus Data (V+D); Part 7: Security".
- [i.2] ETSI TS 100 921: "Digital cellular telecommunications system (Phase 2+) (GSM); Service accessibility (3GPP TS 02.11)".
- [i.3] ETSI EN 300 392-10-19: "Terrestrial Trunked Radio (TETRA); Voice plus Data (V+D); Part 10: Supplementary services stage 1; Sub-part 19: Barring of Incoming Calls (BIC)".
- [i.4] ETSI EN 300 395-2: "Terrestrial Trunked Radio (TETRA); Speech codec for full-rate traffic channel; Part 2: TETRA codec".
- [i.5] ITU-T Recommendation I.130: "Method for the characterization of telecommunication services supported by an ISDN and network capabilities of an ISDN".
- [i.6] ITU-T Recommendation I.140: "Attribute technique for the characterization of telecommunication services supported by an ISDN and network capabilities of an ISDN".
- [i.7] ITU-T Recommendation I.210: "Principles of telecommunication services supported by an ISDN and the means to describe them".
- [i.8] ITU-T Recommendation Z.100: "Specification and Description Language (SDL)".
- [i.9] ITU-T Recommendation V.110: "Support by an ISDN of data terminal equipments with V-Series type interfaces".
- [i.10] ETSI TR 102 300-5: "Terrestrial Trunked Radio (TETRA); Voice plus Data (V+D); Designers' guide; Part 5: Guidance on numbering and addressing".

---

## 3 Definitions and abbreviations

### 3.1 Definitions

For the purposes of the present document, the terms and definitions given in EN 300 392-3-1 [2] and the following apply:

**called SwMI or SwMI B:** Switching and Management Infrastructure to which ANF-ISIIC routes the first call attempt

**fleet call:** call to a closed user group using a Fleet Specific Short Number

NOTE: Refer to TR 102 300-5 [i.10] clause 5.4.3.

**forward switching:** network routing algorithm which performs the routing from SwMI A to SwMI C by joining together the first connection, from SwMI A to SwMI B, and a second connection from SwMI B to SwMI C

**home SwMI:** SwMI which is the home of the MS (or LS) ITSI, i.e. to which the Mobile Network Identity (MNI) which is part of the ITSI belongs

**loop connection:** ISI connection which has both its ends in the same SwMI

**originating SwMI or SwMI A:** Switching and Management Infrastructure in which the calling user has registered

**re-routeing:** network routeing algorithm which performs the routeing from SwMI A to SwMI C by replacing the connection from SwMI A to SwMI B by another connection from SwMI A to SwMI C

**SwMI C:** Switching and Management Infrastructure in which the called user has registered after having migrated from SwMI B, in the case where its home SwMI is SwMI B

**terminating SwMI:** Switching and Management Infrastructure in which the connected user is registered

NOTE: Unless an interaction with one or more supplementary services which modify the routeing of the call (e.g. call forwarding) has occurred, the connected user will be the called user; and the terminating SwMI will be the SwMI where the called user is registered, i.e. SwMI B or SwMI C.

**trombone connection:** special case of loop connection where all inter-TETRA connections making up the loop connection are used twice

NOTE: If no interaction occurs with supplementary services which modify the routeing of the call (e.g. call forwarding), the only loop connection which can be established by an invoked ANF-ISIIC is a trombone connection (i.e. when SwMI C coincides with SwMI A).

## 3.2 Abbreviations

For the purpose of the present document, the following abbreviations apply:

AL	Ambience Listening
ANF	Additional Network Feature
AoC	Advice of Charge
AP	Access Priority
APDU	Application Packet Data Unit
AS	Area Selection
BIC	Barring of Incoming Calls
BOC	Barring of Outgoing Calls
CAD	Call Authorized by Dispatcher
CC	Call Control (PISN functional entity)
CCAp	Call Control Application (SwMI functional entity)
CCBS	Call Completion to Busy Subscriber
CCNR	Call Completion on No Reply
CF	Call Forwarding
CFB	Call Forwarding on Busy
CFNRc	Call Forwarding on Not Reachable
CFNRy	Call Forwarding on No Reply
CFU	Call Forwarding Unconditional
CLIP	Calling Line Identification Presentation
CLIR	Calling/connected Line Identification Restriction
CMCE	Circuit Mode Control Entities
COLP	COConnected Line identification Presentation
CR	Call Report
CRT	Call ReTention
CRV	Call Retention Value
CW	Call Waiting
DGNA	Dynamic Group Number Assignment
DL	Discreet Listening
DTMF	Dual Tone Multi Frequency
FE	Functional Entity
GTSI	TETRA Subscriber Group Identity
HOLD	Call Hold
IC	Include Call
IPE	In-band Parameter Exchange
ISDN	Integrated Services Digital Network
ISI	Inter System Interface
ISIGC	Inter System Interface Group Call
ISIIC	Inter System Interface Individual Call
ISIMM	Inter System Interface Mobility Management

ISISDS	Inter System Interface Short Data Service
ISSS	Inter System Interface Supplementary Service
ITSI	Individual TETRA Subscriber Identity
LE	Late Entry
LS	Line Station
LSC	List Search Call
MLE	Mobile Link Entity
MNI	Mobile Network Identity
MS	Mobile Station
MSC	Message Sequence Charts
NFE	Network Facility Extension
PC	Priority Call
PDU	Protocol Data Unit
PINX	Private Integrated services Network eXchange
PISN	Private Integrated Services Network
PLMN	Public Land Mobile Network
PPC	Pre-emptive Priority Call
PSS1	Private integrated Signalling System number 1
PSTN	Public Switched Telephone Network
QSIG	Q interface SIGnalling protocol
ROSE	Remote Operation Service Element
SDL	Specification and Description Language
SNA	Short Number Addressing
SS	Supplementary Service
SSI	Short Subscriber Identity
SwMI	Switching and Management Infrastructure
TPI	Talking Party Identification
TSSI	Time Slot Sequence Integrity

---

## 4 ANF-ISIIC stage 1 specification

### 4.1 Description

#### 4.1.1 General description

ANF-ISIIC enables individual calls to be set-up from a TETRA user registered in one Switching and Management Infrastructure (SwMI) to another TETRA user registered in another SwMI. ANF-ISIIC operates at the Inter System Interface (ISI) of both SwMI Call Control Applications (CCAs), in such a manner that these calls can be routed through (transit) Private Integrated Services Networks (PISNs). Additionally, for the duration of each call, ANF-ISIIC allows TETRA signalling information to be passed from TETRA SwMI to TETRA SwMI in accordance with the TETRA Individual Call procedures as defined in EN 300 392-2 [1]. In addition ANF-ISIIC participates in call restoration when a user has migrated to another TETRA network during an established call.

The entities with which ANF-ISIIC interacts are the originating and the terminating SwMI CCAs, and in addition, some SwMI databases, especially that of the called user home SwMI.

#### 4.1.2 Qualifications on applicability to telecommunication services

ANF-ISIIC is applicable to all point-to-point circuit mode tele- and bearer services defined in EN 300 392-2 [1]:

- point-to-point TETRA clear mode speech;
- point-to-point TETRA end-to-end encrypted speech;
- point-to-point one slot 2,4 kbit/s, 4,8 kbit/s or 7,2 kbit/s TETRA circuit mode data;
- point-to-point  $N \times 2,4$  kbit/s,  $N \times 4,8$  kbit/s or  $N \times 7,2$  kbit/s TETRA circuit mode data, with  $N = 2, 3$  or  $4$ ;

- point-to-point end-to-end encrypted one slot 2,4 kbit/s, 4,8 kbit/s or 7,2 kbit/s TETRA circuit mode data;
- point-to-point end-to-end encrypted  $N \times 2,4$  kbit/s,  $N \times 4,8$  kbit/s or  $N \times 7,2$  kbit/s TETRA circuit mode data, with  $N = 2, 3$  or  $4$ .

## 4.2 Procedures

### 4.2.1 Provision/withdrawal

Provision of ANF-ISIIC shall always be available.

### 4.2.2 Normal procedures

#### 4.2.2.1 Activation/deactivation/registration/interrogation

ANF-ISIIC shall always be activated.

Registration and interrogation are not applicable to this ANF.

#### 4.2.2.2 Invocation and operation

ANF-ISIIC shall be invoked by SwMI A CCAp, its served user, when a request from a TETRA user for an individual call to another TETRA network is received by this SwMI. The other network SwMI being called SwMI B by definition, SwMI A CCAp will identify SwMI B either:

- through analysis of the destination number when the called user home SwMI is SwMI B; or
- by a migration information when the called user home SwMI is SwMI A and this user has migrated to SwMI B.

In either case, the invoked ANF-ISIIC shall route the call over an inter-TETRA connection to TETRA network B.

ANF-ISIIC shall allow the use of a PISN to interconnect these two SwMIs.

**NOTE:** This implies that ANF-ISIIC needs to be defined as an extension of PISN basic call control as defined by ISO/IEC 11574 [10] and ISO/IEC 11572 [9]. This extension consists in the addition of certain procedures that PISN basic call control is unable to perform satisfactorily for TETRA networks, in remaining compatible with PISN inter-exchange signalling protocol as defined by ISO/IEC 11582 [11].

##### 4.2.2.2.1 Call routing

If the called user is registered in TETRA network B, SwMI B will know the location of this user; ANF-ISIIC shall then allow this SwMI to complete the call with this user, by ensuring the necessary transfer of information with SwMI A.

If the called user has migrated to another SwMI (SwMI C), then ANF-ISIMM as defined in EN 300 392-3-5 [4] will ensure that this is known from its home SwMI.

**NOTE:** SwMI C cannot exist when the called user home SwMI is SwMI A. This is because when a user has migrated first in a given TETRA network 1, and then migrates into a new TETRA network, SwMI A database will now hold the identity of this new network as being that of SwMI B.

Thus SwMI C as defined in clause 3.1 will only exist when the home SwMI of the called user is SwMI B and when this user has migrated.

Then the call shall be either re-routed (from SwMI A) or forward switched (through SwMI B), depending on the ANF mode of operation, refer to EN 300 392-3-5 [4].

The invoked ANF-ISIIC shall detect the specific case where SwMI C coincides with SwMI A. The ANF-ISIIC shall then instruct SwMI A to establish the call as an intra-TETRA call (i.e. avoiding a trombone connection) and clear itself.

#### 4.2.2.2.2 Control of call time-out timers

Call time-out either for the call establishment phase or once the call has been established may be negotiated between SwMI A CCAp and the terminating SwMI (i.e. SwMI B or C) CCAp: for such negotiation SwMI A CCAp shall indicate its time-out for both durations, and the terminating SwMI CCAp should either use these values or if it decides to have a larger one for any of its corresponding timers, send it to SwMI A CCAp. SwMI A CCAp should then use the latter values (for its corresponding timers).

NOTE: While the exchange of time-out values between the two CCAs has been specified in the protocol (see clauses 6.3.1.1, 6.3.1.7, 6.3.1.8 and 6.3.1.14), the use of the time-out values of one CCAp by the other is optional. However if this other CCAp does not use them, the risk of call attempt failure (due to premature call establishment time-out) or call interruption (due to premature call duration time-out) will be increased.

#### 4.2.2.2.3 Transmission control

ANF-ISIIC shall remain operational for the duration of the call, sending and receiving TETRA signalling messages as appropriate under direction of the originating and terminating SwMI CCAs.

The originating SwMI shall be designated as the controlling SwMI for half-duplex operation, and all requests to transmit from the called user shall be directed to this SwMI to be granted, after the call control application of the terminating SwMI shall have reserved the corresponding radio resource for the called user.

#### 4.2.2.2.3a Setup modification

When being established the individual call may be changed into a group call. The invoked ANF-ISIIC shall then become ANF-ISIGC. Similarly a group call may be changed into an individual call. The invoked ANF-ISIGC shall then become ANF-ISIIC.

#### 4.2.2.2.4 Call modification

Call modification as defined in clause 14.5.1.2 of EN 300 392-2 [1] shall have no impact on the basic ISI connection(s) (see table 1) established by the invoked ANF-ISIIC.

NOTE 1: The reason for this is first that the various cases of call modification defined in clause 14.5.1.2 of EN 300 392-2 [1] never cause to exceed the capacity of such basic ISI connection, and second, it is not possible to reduce the ISI connection information transfer rate defined at ANF-ISIIC set-up.

However call modification shall result in a change in the 8 kbit/s encoding of the user information when the data rate of this information changes, because of e.g. a change from data call to speech call, or from 4,8 kbit/s to 7,2 kbit/s or 2,4 kbit/s, and vice-versa.

NOTE 2: The use of the optional ISI connection (see table 2) for call modification is outside the scope of the present document.

#### 4.2.2.2.5 Call restoration after migration

If the calling or the called user migrates and registers in a new TETRA network once an inter-TETRA call has been established, ANF-ISIMM will be invoked to inform the call control application of the SwMI where this migrating user was previously registered (hereafter called the "old SwMI"). Upon request of that call control application, the ANF-ISIIC invoked to establish this call shall then establish a new connection between the old SwMI and the new SwMI, by putting the call on hold. The call restoration request by the migrating user in the new SwMI (see clause 14.5.1.2.4 of EN 300 392-2 [1]) shall result in the held call being transferred by the old SwMI to this migrating user. This transfer shall be by join (i.e. through the old SwMI). It will result in a new connection (between the new network in which the user is now registered and the network where the other user engaged in the call remains registered) which shall be used by the existing ANF-ISIIC.

NOTE 1: Using re-routeing for call restoration has been considered to be too complex.

Figure 1 illustrates this in the case where the calling user has migrated and its home SwMI is not SwMI A.



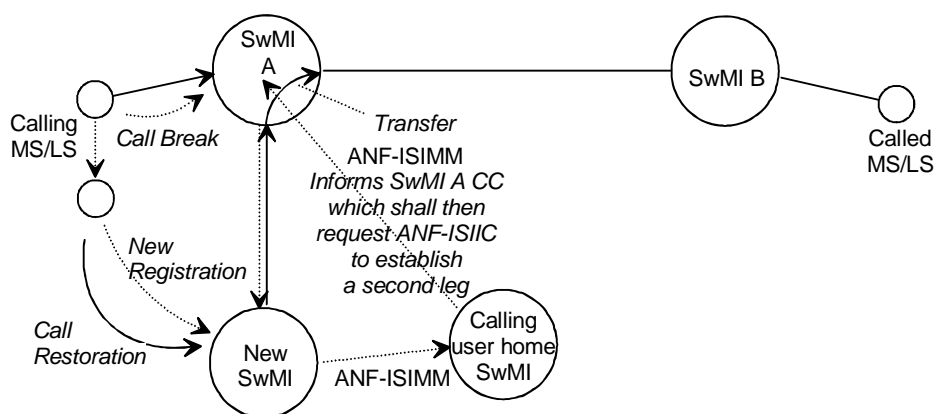

**Figure 1: Call restoration by the calling user having migrated, with its home SwMI being different from SwMI A**

Similarly, if the same migration of the calling or of the called user happens once an inter-TETRA call in a given SwMI has been established, ANF-ISIMM will be invoked to inform the Call Control (CC) entity of this SwMI. This SwMI CC shall invoke ANF-ISIIC to allow a successful call restoration.

NOTE 2: As opposed to the former case of call restoration, where ANF-ISIIC has already been invoked and is then extended to the "new" SwMI by transfer, the latter is a very specific case of ANF-ISIIC invocation.

NOTE 3: When this migration takes place during the establishment of the call, the call will be cleared by the MS/LS, as a result of the detection of the corresponding (radio path) break by its MLE.

NOTE 4: The term "migration" corresponds to what has been defined for GSM as "national roaming": i.e. changing from one GSM Public Land Mobile Network (PLMN) area to another one (see clauses 2.3 and 1.2 of TS 100 921 [i.2]). Thus, using the GSM terminology, TETRA call restoration while migrating would correspond (at least at the stage 1 description level) to "handover" while "roaming nationally", i.e. while leaving one GSM PLMN area and entering a new one.

#### 4.2.2.2.6 Call clearing

When clearing the call on its side, either the originating or the terminating SwMI call control applications shall clear the invoked ANF-ISIIC. This ANF-ISIIC shall then clear the ISI connection, and clear the other SwMI call control application.

NOTE 1: In the originating SwMI, the call may be cleared either by the calling user or by the call control application (e.g. if the SwMI can no longer support the call). Similarly, in the terminating SwMI, the call may be cleared either by the called user or by the call control application.

NOTE 2: Although this is purely formal, since the interfaces between ANF-ISIIC and the call control application are internal to SwMIs, to be consistent with both the stage 1 description of the PISN basic call in ISO/IEC 11574 [10] and the definition of TETRA call control primitives in clause 11 of EN 300 392-2 [1], it will be considered that the clearings between the invoked ANF-ISIIC and the call control applications are acknowledged.

#### 4.2.2.2.7 Interaction between ANF-ISIICs

Due to the fact that a single ANF-ISIIC shall handle the routing of the call either to the called user, even when this user has migrated, only one ANF-ISIIC shall be invoked per individual call. And thus, no interaction can possibly take place in the case of a single individual call.

As stated in the corresponding clauses, this shall also hold in case of interactions with supplementary services, including those which modify the routing of the call (e.g. call forwarding, see clauses 4.3.6 to 4.3.9).

On the other hand, two invoked ANF-ISIIC using or needing a connection between two given SwMIs can interact through some supplementary services:

- the Include Call supplementary service for merging two individual calls into a group call (see clause 4.3.22);
- the Pre-emptive Priority Call supplementary service (see clause 4.3.21) for the invocation of ANF-ISIIC for a new call, to choose whether to operate such newly invoked ANF-ISIIC in clearing an active one, or to reject it.

#### 4.2.2.2.8 Radio traffic channel resource queuing and allocation policies

Due to the TETRA requirement for a fast call set-up time the invoked ANF-ISIIC shall ensure that any queuing for radio traffic channel resources occurs virtually simultaneously in both the originating and terminating SwMIs. Each of the SwMIs shall fully and immediately understand the full state of the call so that the calling and called parties can be kept up to date on any queuing situation.

During call set-up a SwMI may operate one of two radio traffic channel resource allocation policies, these are:

- not to release the radio traffic channel during call set-up, unless the call is cleared (permanent allocation); or
- make the radio traffic channel available for release during call set-up if the call cannot be connected (temporary allocation).

The invoked ANF-ISIIC shall ensure that SwMIs operating different allocation policies can set-up a call between each other. The additional signalling required for the full support of the second option (temporary allocation) may be supported by a particular SwMI.

### 4.2.3 Exceptional procedures

#### 4.2.3.1 Activation/deactivation/registration/interrogation

Not applicable.

#### 4.2.3.2 Invocation and operation

ANF-ISIIC may reject the call request with an appropriate failure indication for any of the following reasons:

- no inter-TETRA connection available, permanently;
- no inter-TETRA connection available, temporarily;
- failed call restoration (see clause 4.2.2.2).

In addition, if the called user has migrated and is now registered in SwMI A but that SwMI had not detected it and had thus invoked an ANF-ISIIC, that invoked ANF-ISIIC shall then inform that SwMI about it in avoiding that the call attempt be established with a trombone connection (see definition of that term in clause 3.1). SwMI A call control application shall then clear the invoked ANF-ISIIC (and will establish the call as an intra-TETRA call).

NOTE: According to the way ANF-ISIMM operates, the latter case cannot arise when the called user home SwMI is SwMI A, since in such a case SwMI A call control application would not have invoked ANF-ISIIC.

The called user SwMI or the terminating SwMI shall clear the invoked ANF-ISIIC in the following cases:

- the called user address is incorrect or invalid;
- unsuccessful outcome of Private Integrated Signalling System Number 1 (PSS1) basic call establishment related to the called user as described in clause 9.3 of ISO/IEC 11574 [10];
- no details concerning the location of the called user are available or they are outdated.

## 4.3 Interactions with other TETRA supplementary services and ANFs

Interactions with other TETRA supplementary services and ANFs for which TETRA Standards were available at the time of publication of the present document are specified in the following clauses.

### 4.3.1 Calling Line Identification Presentation (SS-CLIP)

No interaction.

### 4.3.2 Connected Line identification Presentation (SS-COLP)

No interaction.

### 4.3.3 Calling/connected Line Identification Restriction (SS-CLIR)

In an individual inter-TETRA call, both the originating and the terminating SwMIs shall support SS-CLIR for the user at the other end (e.g. the terminating SwMI shall support SS-CLIR for the calling user).

### 4.3.4 Call Report (SS-CR)

No interaction.

### 4.3.5 Talking Party Identification (SS-TPI)

No interaction.

NOTE: The fact that the ANF-ISIIC invoked for a call carries transparently SS-TPI signalling exchanged between the calling SwMI (A) call control application and the terminating SwMI (B/C) call control application is not to be considered as an interaction.

### 4.3.6 Call Forwarding Unconditional (SS-CFU)

Whenever ANF-ISIIC has been invoked, it shall interact with SS-CFU if the latter has been activated (e.g. by the called user, this user being the SS-CFU served user), unless the incoming call is barred to the called user - by the barring of incoming calls or the call authorized by dispatcher supplementary services.

In addition, when the home SwMI of the called user is SwMI A, SS-CFU shall invoke ANF-ISIIC for forwarding the call if the forwarded-to user home SwMI is different from SwMI A, except possibly when the forwarded-to user happens to be registered in SwMI A after having migrated.

The full specifications of the interactions between SS-CFU and ANF-ISIIC are given in clause 5.6.5 of EN 300 392-12-4 [8].

When the called user home SwMI is SwMI A, the main interaction is the invocation of ANF-ISIIC already mentioned. When the called user home SwMI is SwMI B, the interactions can be summarized as follows:

- unless the called user has migrated and is now registered in SwMI A, the ANF-ISIIC originally invoked for attempting to route the call to the called user shall invoke SS-CFU if it has been activated (in SwMI B) and that ANF-ISIIC shall ensure SS-CFU routing if the forwarded-to user is registered in another SwMI;
- if the called user has migrated and is now registered in SwMI A, then the invoked ANF should check whether another SS-CFU, a local SS-CFU, has been activated in SwMI A for the called user, and if so, it shall not invoke the SS-CFU activated in the home SwMI (thus letting SwMI A CMCE invoke this local SS-CFU);

Still if the called user has migrated and is now registered in SwMI A, if SS-CFU has been activated in the home SwMI for that user and no local SS-CFU, in SwMI A for that same user, then SwMI A call control application shall invoke ANF-ISIIC even if it can route directly calls to called users registered in that SwMI when it is not their home SwMI (i.e. as intra-TETRA calls). The invoked ANF-ISIIC shall itself invoke the SS-CFU activated in the home SwMI.

- if the forwarded-to user has itself activated a call forwarding unconditional supplementary service towards another forwarded-to user and if an ANF-ISIIC had already been invoked, that invoked ANF-ISIIC shall invoke that new call forwarding supplementary service and operate its routing. It shall do so as for the previous SS-CFU provided that:
  - the new forwarded-to user home SwMI is considered as the new SwMI B;
  - if the new forwarded-to user has migrated, the SwMI where he is registered is considered as the new SwMI C; and
  - the last SwMI on the path through which the call attempt has been forward switched is considered as the new SwMI A, i.e. if the new SS-CFU is only the second one, that last SwMI shall be:
    - the originating SwMI if only re-routing has taken place;
    - the home SwMI of the new SS-CFU served user if the call attempt has been forward switched through it; or if different from the previous ones;
    - the home SwMI of the first SS-CFU served user, i.e. the originally called user;
- if the forwarded-to user has itself activated another call forwarding supplementary service than the call forwarding unconditional supplementary service towards another forwarded-to user registered in another SwMI and if an ANF-ISIIC had already been invoked it shall ensure the further routing of the call attempt if necessary, according to the specification of the interaction between ANF-ISIIC and that other call forwarding supplementary service specified in the corresponding clause below provided that:
  - the new forwarded-to user home SwMI is considered as the new SwMI B;
  - if the new forwarded-to user has migrated, the SwMI where he is registered is considered as the new SwMI C; and
  - the last SwMI on the path through which the call attempt has been forward switched is considered as the new SwMI A, i.e. if the new call forwarding supplementary service is only the second call forwarding supplementary service invoked for the call, that last SwMI shall be:
    - the originating SwMI if only re-routing has taken place;
    - the home SwMI of the forwarded-to user for the new call forwarding if the call attempt has been forward switched through it; or if not
    - the SwMI where the forwarded-to user for the initial SS-CFU is currently registered if the call attempt has been forward switched through it; or if different from the previous ones (e.g. if the forwarded-to user for the initial SS-CFU had migrated);
    - the home SwMI of the initial SS-CFU served user, i.e. the originally called user;
- when ensuring the SS-CFU routing mentioned above, the invoked ANF-ISIIC shall avoid loop connection (notably trombone connection) between the originating and the terminating SwMIs (e.g. SwMI where the forwarded-to user is registered coinciding with SwMI A).

In addition, the invoked ANF-ISIIC shall operate the barring of incoming calls supplementary service not only for the originally called user when that user is a SS-CFU served user but for each SS-CFU forwarded-to user (i.e. the SS-CFU forwarded-to user if only one call forwarding unconditional supplementary service is operated for the call, and each of them if many call forwarding unconditional supplementary services are operated for the call).

NOTE: No requirement is included in clause 5.6.5 of EN 300 392-12-4 [8], on the interaction between the call forwarding supplementary services (SS-CF) and SS-BIC, because such interaction has no impact on the definition of SS-CF protocol.

### 4.3.7 Call Forwarding on Busy (SS-CFB)

The interactions between SS-CFB and ANF-ISIIC are similar to those between SS-CFU and ANF-ISIIC, with the main difference that whereas ANF-ISIIC invoked SS-CFU, it shall not invoke SS-CFB: SS-CFB will be invoked by the CMCE entity of the SwMI where its served user is registered (if it has been activated and if that user is busy).

NOTE 1: Thus when the SS-CFB served user has migrated, contrary to SS-CFU, SS-CFB is not invoked in the served user home SwMI.

Another difference, which is a consequence of the main one mentioned above, is that ANF-ISIIC shall not operate any SS-BIC activated for a SS-CFB served user, whether the originally called user or the forwarded-to user for a SS-CF invoked just previously.

The full specifications of these interactions are given in clause 5.6.5 of EN 300 392-12-4 [8]. They are summarized below:

- When the called user is registered in another SwMI than SwMI A, i.e. SwMI B or SwMI C, and that SwMI has invoked SS-CFB (the called user being thus busy) the same ANF-ISIIC invoked for routeing the call attempt from SwMI A to that other SwMI (SwMI B or SwMI C) shall further route the call towards the SwMI where the forwarded-to user is registered when that SwMI is different from the SwMI where the called user is registered (SwMI B or SwMI C). The same ANF-ISIIC invoked for routeing the call attempt from SwMI A to that SwMI may also be used to further route the call in the specific case where the forwarded-to user happens to be registered in that same SwMI after having migrated (i.e. that SwMI is not the forwarded-to user home SwMI but its call control application cannot route directly calls to called users registered there when it is not their home SwMI, i.e. as intra-TETRA calls).
- When the called user is registered in SwMI A, ANF-ISIIC shall be invoked for routeing the call the SwMI where the forwarded-to user is registered if that SwMI is different from SwMI A. It may also be invoked for routeing the call attempt from SwMI A to the forwarded-to user home SwMI in the specific case where the forwarded-to user happens to be registered in SwMI A after having migrated (i.e. SwMI A is not the forwarded-to user home SwMI but its call control application cannot route directly calls to called users registered there when it is not their home SwMI, i.e. as intra-TETRA calls).

NOTE 2: In that specific case where the called user is registered in SwMI A, another SS-CFB, a local SS-CFB, may have been activated in that SwMI. It will then be up to the CMCE entity of that SwMI to invoke that local SS-CFB instead of the general one. Once that local SS-CFB will have been invoked, ANF-ISIIC will be invoked for routeing the call to the forwarded-to user exactly as if the general SS-CFB had been invoked with the same forwarded-to user.

- If the forwarded-to user has itself activated a call forwarding on busy supplementary service towards another forwarded-to user, if an ANF-ISIIC had already been invoked it shall further route the call attempt if necessary as for the previous SS-CFB provided that:
  - the new forwarded-to user home SwMI is considered as the new SwMI B;
  - if the new forwarded-to user has migrated, the SwMI where he is registered is considered as the new SwMI C; and
  - the last SwMI on the path through which the call attempt has been forward switched is considered as the new SwMI A, i.e. if the new SS-CFB is only the second one, that last SwMI shall be:
    - the originating SwMI if only re-routeing has taken place;
    - the home SwMI of the new SS-CFB forwarded-to user if the call attempt has been forward switched through it; or if not
    - the SwMI where the new SS-CFB has been invoked if the call attempt has been forward switched through it; or if not and if different from the previous ones (e.g. if the new SS-CFB served user, i.e. the forwarded-to user of the first SS-CFB, had migrated);
    - the home SwMI of the new SS-CFB served user if the call attempt has been forward switched through it; or if not and if different from the previous ones;

- the SwMI where the first SS-CFB has been invoked if the call attempt has been forward switched through it; or if not and if different from the previous ones (e.g. if the first SS-CFB served user, i.e. the originally called user, had migrated);
  - the home SwMI of that originally called user.
- If the forwarded-to user has itself activated a call forwarding unconditional supplementary service and ANF-ISIIC had already been invoked for the routing of the call attempt, that ANF-ISIIC shall invoke this new supplementary service and operate its routing according to clause 4.3.6, provided that:
  - the new forwarded-to user home SwMI is considered as the new SwMI B;
  - if the new forwarded-to user has migrated, the SwMI where he is registered is considered as the new SwMI C; and
  - the last SwMI on the path through which the call attempt has been forward switched is considered as the new SwMI A, i.e. if the new SS-CFU is only the second call forwarding supplementary service invoked for the call, that last SwMI may be:
    - the originating SwMI if only re-routing has taken place;
    - the home SwMI of the new SS-CFU forwarded-to user if the call attempt has been forward switched through it; or if not
    - the home SwMI of the new SS-CFU served user, i.e. the forwarded-to user of the initial SS-CFB, if the call attempt has been forward switched through it; or if not and if different from the previous ones;
    - the SwMI where the initial SS-CFB has been invoked if the call attempt has been forward switched through it; or if not and if different from the previous ones (e.g. if the initial SS-CFB served user, i.e. the originally called user, had migrated);
    - the home SwMI of that originally called user.
- When ensuring the SS-CF routing mentioned above, this invoked ANF-ISIIC shall avoid loop connection (notably trombone connection) between the originating and the terminating SwMIs (e.g. SwMI where the forwarded-to user is registered coinciding with SwMI A).

In addition, the invoked ANF-ISIIC shall operate the barring of incoming calls supplementary service not only for the originally called user when that user is a SS-CFB served user but for each SS-CFB forwarded-to user (i.e. the SS-CFB forwarded-to user if only one call forwarding on busy supplementary service is operated for the call, and each of them if many call forwarding on busy supplementary services are operated for the call).

NOTE 3: See note in clause 4.3.6.

### 4.3.8 Call Forwarding on No Reply (SS-CFN<sub>Ry</sub>)

The interactions between SS-CFN<sub>Ry</sub> and ANF-ISIIC shall be the same as those between SS-CFB and ANF-ISIIC (see clause 4.3.7).

NOTE: This requirement is valid only for the stage 1 description. Notably this not true for the specification of the ANF-ISIIC protocol (since in the case of SS-CFN<sub>Ry</sub> operation with an ANF-ISIIC already invoked a PSS1 ALERTING message is sent before a possible PSS1 FACILITY message carrying an ANF-ISIIC re-routing PDU).

### 4.3.9 Call Forwarding on Not Reachable (SS-CFN<sub>Rc</sub>)

There are two cases for the invocation and operation of SS-CFN<sub>Rc</sub>:

- when the served user home SwMI has been previously informed that the SS-CFN<sub>Rc</sub> served user is not reachable (e.g. he has deregistered). This case is qualified in clause 5.6.4 of EN 300 392-12-4 [8] as "early" CFN<sub>Rc</sub>;

- when it is only when attempting to set-up the call to the SS-CFNRC served user, as called party, that the SwMI where that user is registered finds out that such user is not reachable. This case is qualified in clause 5.6.4 of EN 300 392-12-4 [8] as "late" CFNRC.

These interactions between SS-CFNRC and ANF-ISIIC shall be the same as the same as those:

- between SS-CFU and ANF-ISIIC (see clause 4.3.6) in the case of "early" CFNRC; and
- between SS-CFB and ANF-ISIIC (see clause 4.3.7) in the case of "late" CFNRC.

#### 4.3.10 List Search Call (SS-LSC)

No interaction.

NOTE 1: SS-LSC will interact with SwMI A CC, which itself will invoke the ANF for calling a user in the list. But this is not an interaction between ANF-ISIIC and SS-LSC.

NOTE 2: The statement that there is no interaction implies that the choice has been made to invoke ANF-ISIIC every time a call is attempted to the next user (registered in another SwMI) in SS-LSC list (i.e. ruling out the possibility of invoking ANF-ISIIC only once for two consecutive users in this list, in the case where these two users would be registered in the same SwMI).

#### 4.3.11 Call Authorized by Dispatcher (SS-CAD)

SS-CAD shall interact with ANF-ISIIC as follows:

- for source restricted calls, the SS-CAD control entity in the originating SwMI shall invoke ANF-ISIIC when SS-CAD operation requires that the outgoing call be diverted to the dispatcher and when this dispatcher is located in a SwMI different from the SwMI in which the restricted (calling) user is registered (i.e. this dispatcher would then be able to discuss with the calling user before allowing or not the establishment of the requested call, as opposed to a simple authorization based only on sending to this dispatcher the calling and called numbers by signalling);

NOTE 1: The call establishment will then be suspended by the originating SwMI call control and supplementary service control applications.

- once the dispatcher has approved the call, if a call had been established with this dispatcher, the ANF-ISIIC invoked towards the dispatcher shall transfer the call to the called user;

NOTE 2: If no call has been established with a dispatcher, SS-CAD will request the SwMI call control and supplementary service control applications which suspended the call establishment to resume it.

- for destination restricted calls, the same procedure as for source restricted calls shall apply for the calls for which ANF-ISIIC has not already been invoked. This shall be the case for intra-TETRA calls either source restricted but with a "local" dispatcher, or not source restricted. It shall also be the case for inter-TETRA calls to a called user who has migrated with his home SwMI being the originating SwMI;
- for destination restricted inter-TETRA calls to a called user the home SwMI of which is the called SwMI (i.e. the called user SwMI is not SwMI A, but SwMI B), the invoked ANF-ISIIC shall invoke and operate SS-CAD. Notably when this operation requires that the incoming call be diverted to the dispatcher and when this dispatcher is located in a SwMI different from the called SwMI, this ANF-ISIIC shall divert the call to the dispatcher. If this call is authorized by SS-CAD, this ANF-ISIIC shall transfer the call to the called user in re-routing it from the called user home SwMI (i.e. SwMI B). And if in addition the called user has migrated to SwMI A, the invoked ANF-ISIIC shall pass the necessary information to call control and supplementary service control applications of this SwMI e.g. so that no local SS-BIC may be invoked for this call;

NOTE 3: If SS-CAD has been activated for both the outgoing call and the incoming call, it will be invoked separately for each.

NOTE 4: In the special case where the called user (has migrated and) is now registered in SwMI A and where SwMI A call control application can route directly (i.e. without invoking ANF-ISIIC) calls to called users registered in this same SwMI when it is not their home SwMI (i.e. they have migrated), SwMI A call control and supplementary service control applications need to be informed about the activation of SS-CAD in the called user home SwMI, to invoke it. This is why ANF-ISIMM will ensure that whenever a user which has activated SS-CAD in his home SwMI migrates to another network, the SwMI of this other network will be informed about this SS-CAD activation.

- contrary to its normal operation, ANF-ISIIC shall make no attempt to avoid any trombone connection or more generally loop connection in routeing the diverted call to the dispatcher from SwMI B;

NOTE 5: The reason for this is that the resulting re-routeing would by-pass SwMI B, wherefrom the ANF-ISIIC call establishment will continue after it has been authorized by the dispatcher; this continuation being either by transfer:

- internal to SwMI B if the called user has not migrated;
  - by forward switching in SwMI B if the called user has migrated to another SwMI than SwMI A; or
  - by transfer with re-routeing in SwMI A if the called user has migrated into SwMI A.
- if the call has been diverted to the dispatcher, after the dispatcher has authorized the call establishment to be resumed, the SS-CAD diverting SwMI shall ensure that the transmission permission granting to the terminating SwMI does not result in any change for the originating SwMI call control application, i.e.:
    - if the calling user had been granted permission to transmit when the dispatcher authorizes the call to be resumed, the diverting SwMI shall ensure that the set-up message that it is sending to the terminating SwMI does not grant transmission permission to the called user;
    - if it is the dispatcher who had been granted permission to transmit when the dispatcher authorizes the call to be resumed, the diverting SwMI shall ensure that the set-up message that it is sending to the terminating SwMI grants transmission permission to the called user;
  - when the originating SwMI call control application receives the response from the terminating SwMI after the call has been diverted to a dispatcher, it shall act as if the call had not been diverted for all applicable supplementary services which it supports, e.g. SS-CLIP, SS-COLP, SS-CLIR, SS-TPI, SS-CCBS and SS-CCNR. This shall hold even if for the originating SwMI does not support SS-CAD.

#### 4.3.12 Short Number Addressing (SS-SNA)

No interaction.

#### 4.3.13 Area Selection (SS-AS)

The SwMI shall use this information to set-up the individual call and may also be used during call restoration.

NOTE 1: When Area Selection is invoked for an individual call, the SS-AS signalling is transported transparently between the originating SwMI and the terminating SwMI and is not considered to be an interaction.

NOTE 2: The area selection is encoded differently in the ISI protocol that in the air interface and the corresponding information element is named as "selected area number".

#### 4.3.14 Access Priority (SS-AP)

No interaction (since SS-AP applies only locally at the radio access).



### 4.3.15 Priority Call (SS-PC)

If SS-PC has been activated, ANF-ISIIC shall interact with SS-PC if this operates by queuing for accessing inter-TETRA connection(s) necessary for its routing. Such interaction shall consist in having every newly invoked ANF-ISIIC competing with the other invoked ANF-ISIIC and ANF-ISIGC still in the inter-TETRA connection allocation queue, when the number of those connections available has fallen below a certain threshold. In such a case, it shall inform SwMI A CC about this.

NOTE: In the case where there is a risk of congestion due to an insufficient number of inter-TETRA connections between two SwMIs for the offered traffic, it would be recommended to split these inter-TETRA connections into two groups, one of which would be reserved to priority calls (i.e. these calls could be routed on any connection of the two groups, while the "ordinary" could only be routed on a connection of the second group).

If SS-PC has been invoked for the call and if SwMI B supports SS-PC, in the case where the ANF-ISIIC invoked for this same call routes it to SwMI C by forward switching, such queuing shall be operated first in SwMI A, and second in SwMI B.

### 4.3.16 Call Waiting (SS-CW)

No interaction.

### 4.3.17 Call Hold (SS-HOLD)

No interaction.

### 4.3.18 Call Completion to Busy Subscriber (SS-CCBS)

When the calling user and the called user are registered in different SwMIs, SS-CCBS shall invoke an ANF-ISIIC for its operation, either for (SS-CCBS) path reservation, or if the latter is not implemented (by SS-CCBS), when the call to the called user is reinitiated.

NOTE: When the called user migrates while remaining busy (e.g. its established call is restored - see clause 4.2.2.2), all SS-CCBS pending invocations (i.e. not yet completed or cancelled) to this called user will be passed to the new SwMI where this user has registered. But this passing is not an interaction between SS-CCBS and ANF-ISIIC, since it will not be done by the latter.

### 4.3.19 Late Entry (SS-LE)

No interaction (since SS-LE does not apply to TETRA individual calls).

### 4.3.20 Void

No interaction (since SS-TC does not apply to TETRA individual calls).

### 4.3.21 Pre-emptive Priority Call (SS-PPC)

SS-PPC shall interact with ANF-ISIIC to pre-empt the inter-TETRA connection with the lowest Call Retention Value (CRV) among those which may be used to route the priority call. SS-PPC shall operate such pre-emption first in forcing the clearing of this inter-TETRA connection (with its normal operation for the connected parties to be released), and then in invoking a new ANF-ISIIC at the corresponding ISI.

NOTE: If inter-TETRA connections between the originating SwMI and the terminating one are not direct, but are established by transit through a PISN, it would be desirable that this PISN offers some mechanism to assess the priority level of each possible inter-TETRA connections between these two SwMIs.

### 4.3.22 Include Call (SS-IC)

SS-IC and ANF-ISIIC shall interact whenever the SS-IC served user is engaged with a user registered in a different SwMI in an individual call to be included in a group call (by SS-IC).

The requirement for this interaction is to be able to change the call bearer capability from point-to-point (for the individual call) into point-to-multipoint. Such change shall be controlled by SS-IC.

In the case where the other user engaged in an individual call with the served user, is not the only group call participant registered in its SwMI, either the inter-TETRA connection established by ANF-ISIIC for this individual call shall be released, or it shall be used for the new group call.

In addition whatever SwMI was controlling the simplex transmission in the individual call shall release this control to the controlling SwMI of the new group call.

### 4.3.23 Advice of Charge (SS-AoC)

When SS-AoC-E and ANF-ISIIC have both been invoked for a call (i.e. delivery of charging information at the end of a call has been requested for an inter-TETRA call, or an external call routed over the ISI), both shall interact in the case where the served user wants to clear the call. In such a case, the SwMI which is controlling the served user shall not clear the invoked ANF-ISIIC. Instead, it shall request this invoked ANF-ISIIC to ensure the delivery of charging information for this call. Only after it has got such information, shall the invoked ANF-ISIIC clear the call, in ensuring that this information is transferred to the SwMI which is controlling the served user.

The same shall apply when SS-AoC-D and ANF-ISIIC have both been invoked for a call (since SS-AoC-D delivers charging information at the end of a call).

### 4.3.24 Barring of Outgoing Calls (SS-BOC)

No interaction.

NOTE: SS-BOC is operated by SwMI A call control and supplementary service control applications.

### 4.3.25 Barring of Incoming Calls (SS-BIC)

No interaction when the called user home SwMI is SwMI A (i.e. SS-BIC shall be invoked and operated by SwMI A call control and supplementary service control applications).

When the called user home SwMI is SwMI B, the ANF-ISIIC invoked to establish the call with the called user shall invoke SS-BIC, except in the special case presented below.

In the special case where the called user (has migrated and) is now registered in SwMI A, where it has activated another SS-BIC in SwMI A for intra-TETRA calls and where SwMI A call control application has invoked ANF-ISIIC to establish the call with the called user, then this ANF-ISIIC shall operate as follows:

- it shall check whether a local SS-BIC has been activated;
- if so, it shall by-pass the invocation of the home SwMI SS-BIC (i.e. if a local SS-BIC has been activated, the home SwMI SS-BIC will not be invoked for this special case of intra-TETRA call) in invoking and operating this local SS-BIC;
- only if no local SS-BIC has been activated, shall the invoked ANF-ISIIC invoke and operate the home SwMI SS-BIC;
- if the operation of the relevant SS-BIC results in having the call barred, the invoked ANF-ISIIC shall clear the call;
- if the operation of the relevant SS-BIC results in having the call authorized, there shall be no more interaction between SS-BIC and ANF-ISIIC.

NOTE 1: As stated in clause 4.2.3.2, the invoked ANF-ISIIC will clear itself in informing SwMI A Call Control Application about the situation.

NOTE 2: On the other hand another issue arises if SwMI A call control application can route directly (i.e. without invoking ANF-ISIIC) calls to called users registered in this same SwMI when it is not their home SwMI (i.e. they have migrated). This issue is that, if no local SS-BIC has been activated, SwMI A Call Control and Supplementary Service control applications needs to be informed about the activation of SS-BIC in the called user home SwMI, to invoke it. This is why ANF-ISIMM will ensure that whenever a user which has activated SS-BIC in its home SwMI migrates to another network, the SwMI of this other network will be informed about this SS-BIC activation.

NOTE 3: When SS-CAD has also been activated for the called user (see clause 4.3.11), its invocation will take precedence over that of SS-BIC, according to the definition of the interaction between these two supplementary services - in EN 300 392-10-19 [i.3].

#### 4.3.26 Discreet Listening (SS-DL)

When SS-DL has been invoked, if the user being listened to and the monitoring user are registered in two different SwMIs, SS-DL shall invoke an ANF-ISIIC for its operation.

Only one ANF-ISIIC shall be invoked by SS-DL, even when the call being listened to by the invoked SS-DL is an inter-TETRA individual call.

NOTE: In the latter case, SS-DL will use a listening bridge in the SwMI where the user being listened to is registered, so that the same invoked ANF-ISIIC will be used independently of which user is talking/sending.

But in the specific case where the other party engaged in the inter-TETRA individual call being listened to by the invoked SS-DL is registered in the same SwMI as the listening user, SS-DL shall still use a specifically invoked ANF-ISIIC for its operation.

#### 4.3.27 Ambience Listening (SS-AL)

Then the SS-AL served user (i.e. the monitoring party) monitors an MS/LS registered in a given SwMI, if this user is registered in a different SwMI, SS-AL shall invoke an ANF-ISIIC for its operation.

#### 4.3.28 Dynamic Group Number Assignment (SS-DGNA)

No interaction (since SS-DGNA is not applicable to individual calls).

#### 4.3.29 Call Completion on No Reply (SS-CCNR)

When the calling user and the called user are registered in different SwMIs, SS-CCNR shall invoke an ANF-ISIIC for its operation, either for (SS-CCNR) path reservation, or if the latter is not implemented (by SS-CCNR), when the call to the called user is reinitiated.

NOTE: When the called user migrates, all SS-CCNR pending invocations (i.e. not yet completed or cancelled) to this called user will be passed to the new SwMI where this user has registered. But this passing is not an interaction between SS-CCNR and ANF-ISIIC, since it will not be done by the latter.

#### 4.3.30 Call Retention (SS-CRT)

SS-CRT shall interact with the ANF-ISIIC in having the Call Retention Value (CRV) of the call for which both have been invoked assigned to the inter-TETRA connection(s) over which this call will have been routed.

### 4.3.31 Additional Network Feature - Inter System Interface Group Call (ANF-ISIGC)

The only interactions between ANF-ISIGC and ANF-ISIIC shall be through the include call supplementary service (see clause 4.3.22).

NOTE: Even when all "group participants" but one have left a group call (i.e. only the group call owner and the last "group participant" are remaining in the call active state), the call remains a group call - so as to allow the easy introduction of a new (participant) user in this group.

### 4.3.32 Additional Network Feature - Inter System Interface Short Data Service (ANF-ISISDS)

No interaction.

### 4.3.33 Additional Network Feature - Inter System Interface Mobility Management (ANF-ISIMM)

No interaction.

NOTE 1: Even in the case of call restoration, ANF-ISIMM does not interact with ANF-ISIIC: it interacts only with the call control application of the SwMI concerned - and it is this call control application which interacts with ANF-ISIIC.

NOTE 2: All updating of the SwMI databases used for the operation of ANF-ISIIC are not to be considered as interactions between ANF-ISIMM and ANF-ISIIC.

### 4.3.34 Additional Network Feature - Inter System Interface Supplementary service (ANF-ISISS)

No interaction.

NOTE: The fact the ANF-ISISS can be invoked for carry such supplementary service information together with some specific TETRA basic call one (e.g. in the TETRA set-up message) is not an interaction.

## 4.4 Interworking considerations

ANF-ISIIC and PSTN shall interwork in the case of PSTN call through a TETRA gateway located in a SwMI different from that where the TETRA user involved in this call is registered. For an outgoing call (i.e. from a TETRA calling user), SwMI A call control application will invoke an ANF-ISIIC to route the call over an ISI to the PSTN gateway. This ANF shall send to SwMI B call control application the PSTN called number (received from SwMI A call control application), and indicate whether the call is a telephony call or a data call (through a bearer service request). In the latter case, the gateway will use a modem belonging to its modem pool for the duration of the call. Before ensuring the data exchange between the PSTN and the gateway SwMI, this modem will first establish (automatically) the call to the called user modem and negotiate the data rate with the latter modem.

NOTE 1: A TETRA speech (tele-) service call will result in a standard PSTN telephony call. But a TETRA data service call to a PSTN may result in a TETRA bearer service negotiation, depending on the modem rate negotiation between the modem of the PSTN called user and the PSTN gateway modem.

For an incoming telephony call (i.e. to a TETRA called user), the PSTN calling user will have to send the number of the called user to the TETRA PSTN gateway. This will be done using DTMF (in-band) dialling. After the gateway has detected the DTMF digits it will convert the corresponding decimal number into an ITSI or GTSI number. Then if the analysis made by the call control application of the SwMI where this gateway is located shows first that the SSI of the called user corresponds to an ITSI number, and not to a GTSI one (i.e. the type of call requested is an individual call and not a group call), and second that the called user is registered in another SwMI, this will result in a standard invocation of an ANF-ISIIC to extend the individual call requested to the called user. This ANF will use the ITSI number converted from the received DTMF digits as the called number.

NOTE 2: A PSTN telephony call will result in a TETRA speech (tele-) service call.

A similar procedure will apply for an incoming data call, with the difference that this call would first be connected by the gateway to some modem.

NOTE 3: The DTMF addressing procedure is not compatible with the standard procedures for automatic calls by modems.

NOTE 4: For such data calls from PSTN, TETRA bearer service negotiation will be possible with the called SwMI or the TETRA called user, but only if the called SwMI can inform fast enough the gateway modem on the bearer service that it supports (otherwise the negotiation phase between the two modems involved in the call establishment - one on the calling party side, the other, part of the PSTN gateway modem pool - will be over).

ANF-ISIIC and Integrated Services Digital Network (ISDN) shall interwork in the case of ISDN call through a TETRA gateway located in a SwMI different from that where the TETRA user involved in this call is registered.

For an outgoing call (i.e. from a TETRA calling user), the interworking will be the same as that between ANF-ISIIC and PSTN, in replacing PSTN number by ISDN number: SwMI A call control application will invoke an ANF-ISIIC to route the call over an ISI to the ISDN gateway. This ANF shall send to SwMI B call control application the ISDN called number (received from SwMI A call control application). Only the PSTN numbering plan will be used for this ISDN called number (since there is no means for the calling user to indicate any other numbering plan, neither to indicate any corresponding type of number). For a data call, instead of a modem procedure, the rate adaptation procedure defined in ITU-T Recommendation V.110 [i.9] will be used. The data rate for the call might then be negotiated using the (optional) In-band Parameter Exchange (IPE) procedure described in appendix I of ITU-T Recommendation V.110 [i.9].

NOTE 5: A TETRA speech (tele-) service call will result in an ISDN telephony tele-service. Similarly a TETRA data service call will result in an ISDN 64 kbit/s with the following bearer service attribute values: information transfer capability value equal to unrestricted digital information, and layer 1 access protocol value corresponding to the rate adaptation in accordance with ITU-T Recommendation V.110 [i.9].

For an incoming call (i.e. to a TETRA called user), contrary to the case of a PSTN calling user, the ISDN calling user can send the address of the called user to the TETRA ISDN gateway. It will do this using one of the various means available (e.g. using the ISDN supplementary services sub-addressing or user to user signalling). And this calling user can also indicate the type of call, telephony or data call, through the bearer service requested.

NOTE 6: An ISDN telephony tele-service will result in a TETRA speech (tele-) service call. And an incoming ISDN call requesting a bearer capability defined by an information transfer capability value equal to unrestricted digital information, and a layer 1 access protocol value corresponding to the rate adaptation in accordance with ITU-T Recommendation V.110 [i.9], will result in a TETRA data call.

The data rate for the call might then be negotiated using the (optional) IPE procedure described in appendix I of this ITU-T Recommendation V.110 [i.9].

ANF-ISIIC and PISN shall interwork in the case of PISN call through a TETRA gateway located in a SwMI different from that where the TETRA user involved in this call is registered. This interworking shall be exactly the same as that described above between ANF-ISIIC and ISDN, in replacing ISDN number by PISN number.

NOTE 7: The fact that ANF-ISIIC allows to use PISN to interconnect the SwMIs involved in inter-TETRA individual calls is not to be considered as interworking at stage 1 level.

NOTE 8: Another possibility to make an external outgoing call is first to establish an inter-TETRA call with the gateway, and then to send the called number digits (by the DTMF air interface information elements) to this gateway (i.e. two stage dialling, already mentioned in clause 14.5.1.2.5 of EN 300 392-2 [1]). It has not been addressed above, since from a formal point of view, it can hardly be considered as a true interworking case.

## 4.5 Static description of ANF-ISIIC using attributes

In accordance with ITU-T Recommendation I.210 [i.7], the static description of ANF-ISIIC is given below using the relevant attributes with the corresponding values as defined in ITU-T Recommendation I.140 [i.6].

ANF-ISIIC is extending over the ISI the TETRA bearer or tele- service invoked by an individual call calling user, by creating the necessary connection between the originating and the terminating SwMIs. The corresponding bearer service attributes are given in annex A, which is informative (since it is simply reformulating the corresponding information defined in EN 300 392-2 [1]).

Using the terminology defined in ITU-T Recommendation I.140 [i.6], the connection to be created by ANF-ISIIC as a result of its invocation and operation is a connection element.

Table 1 defines the static description of this connection element in terms of the values of its attributes as listed in ITU-T Recommendation I.140 [i.6].

As an option another set of values is defined in table 2 for networks which can handle multirate 8 kbit/s calls (i.e. networks which first can handle 8 kbit/s - instead of or in addition to the standard 64 kbit/s channels, and second can establish calls involving more than one such channel).

NOTE 1: The attributes in tables 1 and 2 have been grouped into categories in a similar manner as in ITU-T Recommendation I.210 [i.7] for the bearer service attributes.

As already stated in clause 4.2.2.2, call modification shall have no impact on the connection(s) established by the invoked ANF-ISIIC, but it shall result in a change in the 8 kbit/s encoding of the user information when the data rate of this information changes. Thus the access attribute Information transfer coding/protocol in the static descriptions of the ISI connection elements in tables 1 and 2 may change when a call modification occurs. No other attribute in these tables shall change.

NOTE 2: This means that even if the ISI connection has been established as an  $N \times 8$  kbit/s connection (see table 2), the number  $N$  of 8 kbit/s ISI channels used for the call will not change. The reason for this is first that the various cases of call modification defined in clause 14.5.1.2 of EN 300 392-2 [1] never result in an increased number of ISI 8 kbit/s channels, and second, the definition of PISN multirate calls does not cater for the possibility of reducing the number of channels used for the call at set-up time.

As to the case of 64 kbit/s connection elements, addressed in table 1, obviously there is no possibility to change the information transfer rate of these connection elements.

**Table 1: Basic definition of ANF-ISIIC connection element attributes**

Attribute category	Attribute name	Attribute value
Information transfer attributes	1. Information transfer mode: 2. Information transfer rate: 3. Information transfer capability: 4. Structure: 5. Establishment of connection: 6. Symmetry: 7. Connection configuration:	circuit 64 kbit/s no restriction (see note) 8 kHz integrity Demand bi-directional symmetric point-to-point
Access attributes	8. Channel: 9. Connection control protocol: 10. Information transfer coding/ protocol:	B <sub>Q</sub> for user information, D <sub>Q</sub> for signalling PSS1 for D <sub>Q</sub> -channel Encoding of each TETRA slot into an 8 kbit/s stream. In case of a (TETRA) multi-slot bearer service, the resulting 8 kbit/s streams shall be multiplexed as defined in ITU-T Recommendation I.460 [12]
General attributes	11. Network performance: 12. Network interworking: 13. Operations and management aspects:	for further study for further study for further study
NOTE:	According to the definition of the attribute information transfer capability of a connection element in ITU-T Recommendation I.140 [i.6], the value of this attribute for the ANF-ISIIC connection element should be "null". Since this value means that there is no restriction to the types of information which may pass through the connection element, the term "no restriction" has been preferred.	

**Table 2: Optional definition of ANF-ISIIC connection element attributes**

Attribute category	Attribute name	Attribute value
Information transfer attributes	1. Information transfer mode: 2. Information transfer rate: 3. Information transfer capability: 4. Structure: 5. Establishment of connection: 6. Symmetry: 7. Connection configuration:	circuit N × 8 kbit/s (with n = 1, 2, 3 or 4) no restriction (see note) Time Slot Sequence Integrity (TSSI) demand bi-directional symmetric point-to-point
Access attributes	8. Channel: 9. Connection control protocol: 10. Information transfer coding/ protocol	8 kbit/s channels for user information, D <sub>Q</sub> for signalling PSS1 for D <sub>Q</sub> -channel Encoding of each TETRA slot into an 8 kbit/s stream
General attributes	11. Network performance: 12. Network interworking: 13. Operations and management aspects:	for further study for further study for further study
NOTE:	According to the definition of the attribute information transfer capability of a connection element in ITU-T Recommendation I.140 [i.6], the value of this attribute for the ANF-ISIIC connection element should be "null". Since this value means that there is no restriction to the types of information which may pass through the connection element, the term "no restriction" has been preferred.	

## 4.6 Overall SDL

Figure 2 contains the dynamic description of ANF-ISIIC using the Specification and Description Language (SDL) defined in ITU-T Recommendation Z.100 [i.8]. The SDL process represents the behaviour of the set of SwMI entities involved, interconnected by the intervening network, possibly by a PISN, in providing ANF-ISIIC.

Output/input signals from/to the left represent primitives from/to SwMI A CC. Output/input signals from/to the right represent primitives from/to the CC of the SwMI in which the called user is registered (i.e. SwMI C in the case of re-routing or forward switching, and SwMI B otherwise), except in the case of forward switching where some output/input signals from/to the right represent primitives from/to SwMI B CC. The latter are to establish first the second leg of forward switching and then SwMI B transit operation.

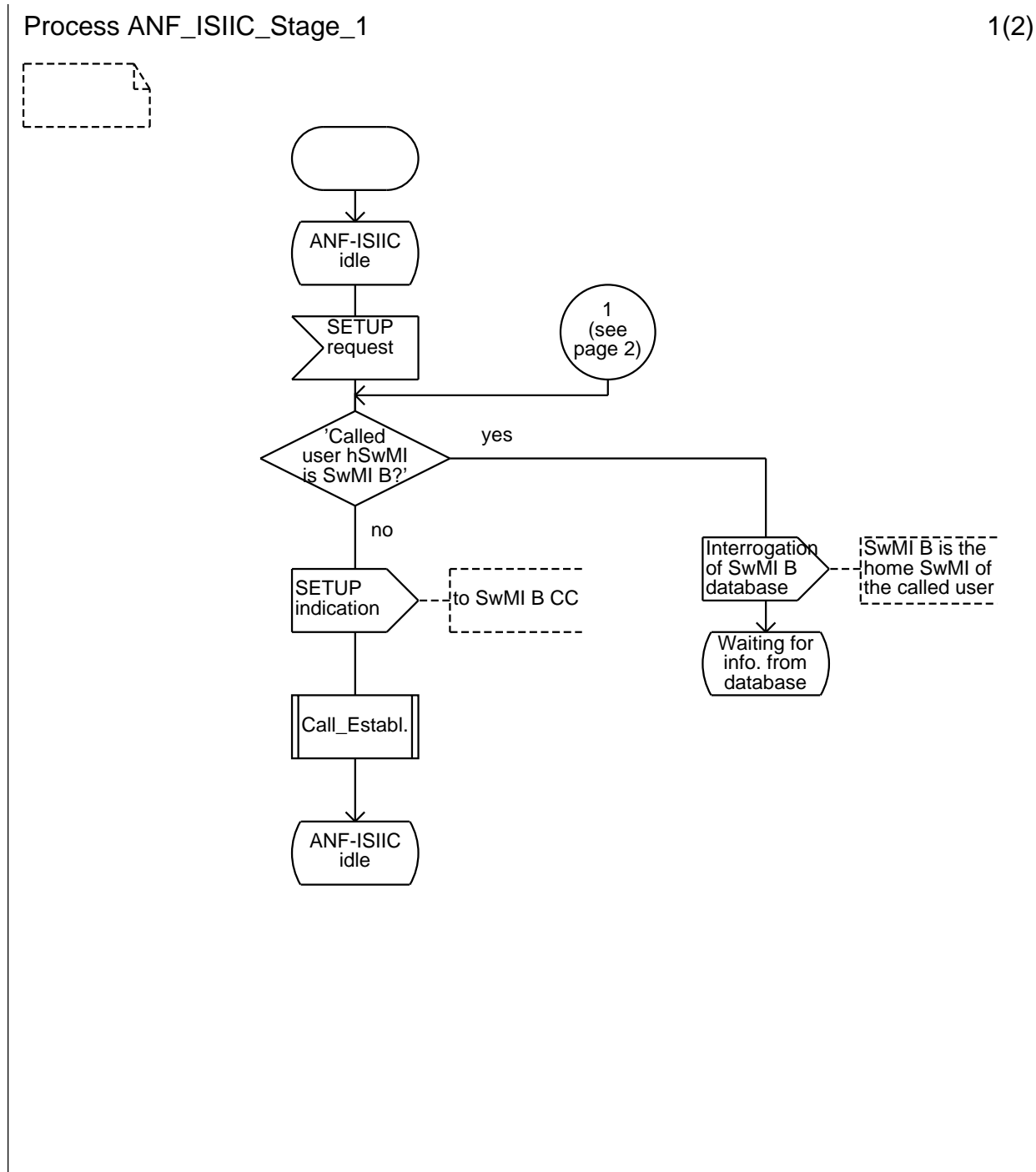

Figure 2 (sheet 1 of 5): ANF-ISIIC, overall SDL  
Main diagram



Process ANF-ISIIC\_Stage\_1

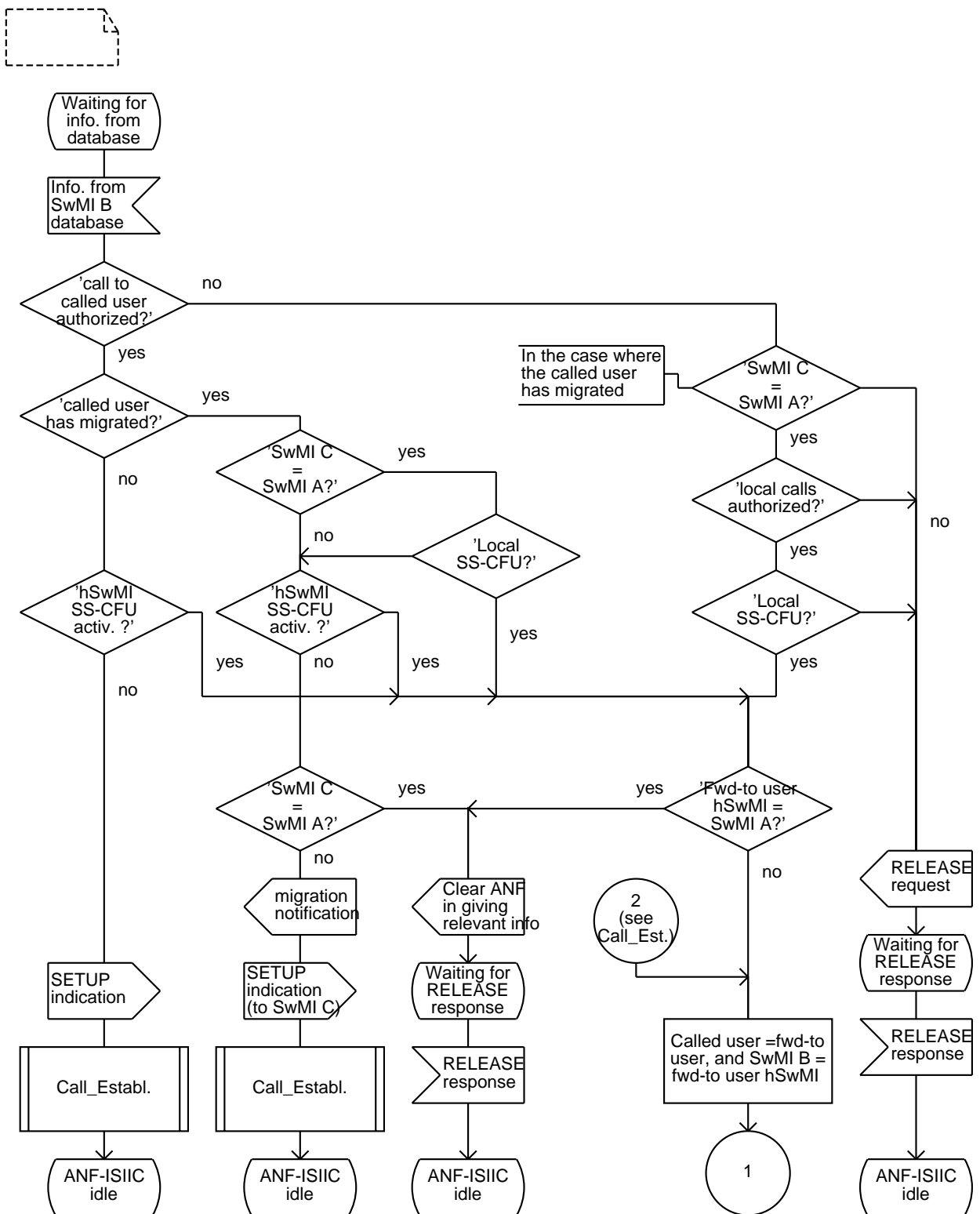

Figure 2 (sheet 2 of 5): ANF-ISIIC, overall SDL Main diagram

Procedure Call\_Establ.

1(1)

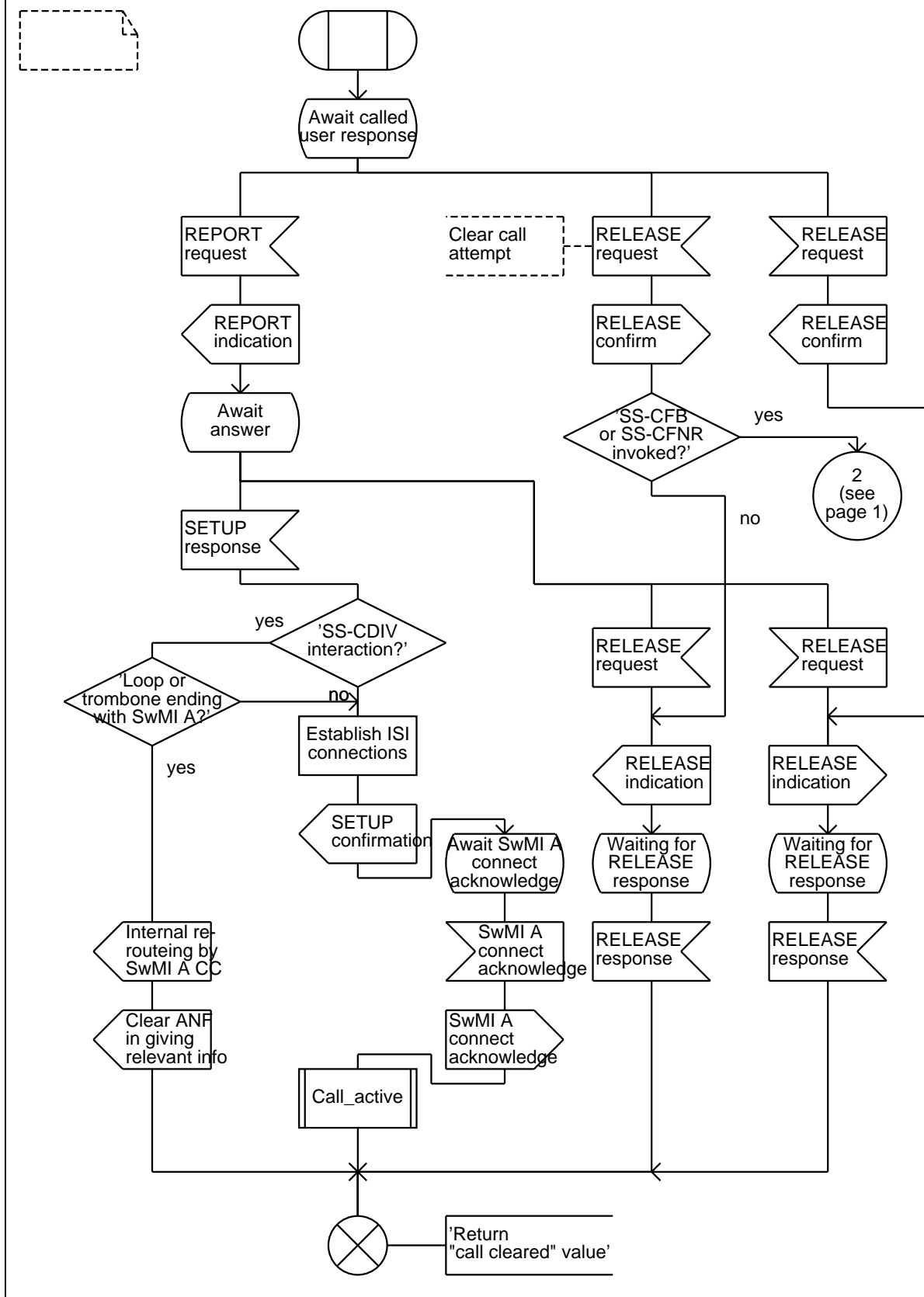

Figure 2 (sheet 3 of 5): ANF-ISIIC, overall SDL Call establishment procedure

Procedure Call\_active

1(1)

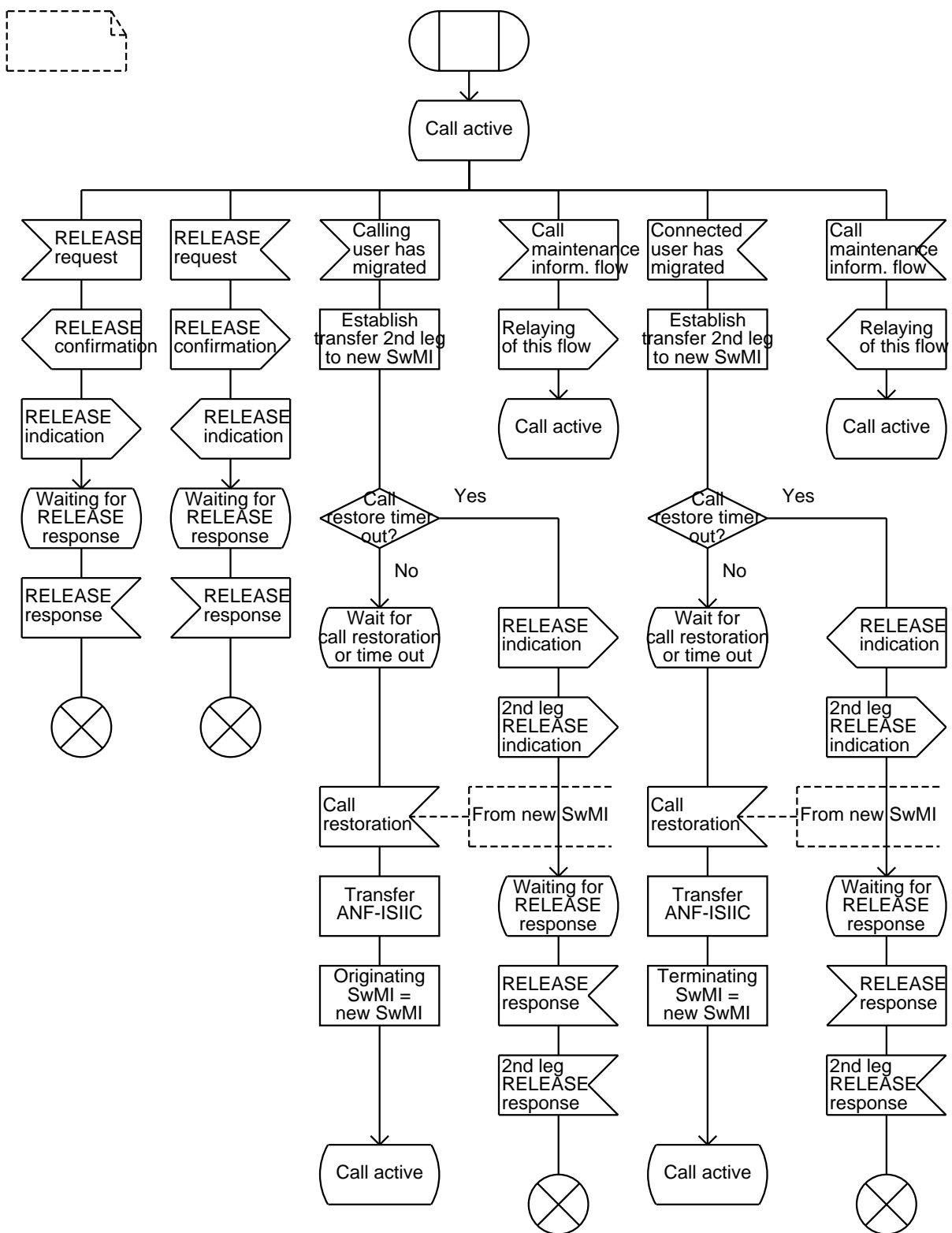

Figure 2 (sheet 4 of 5): ANF-ISIIC, overall SDL Call active procedure

Procedure Call\_active

1(1)

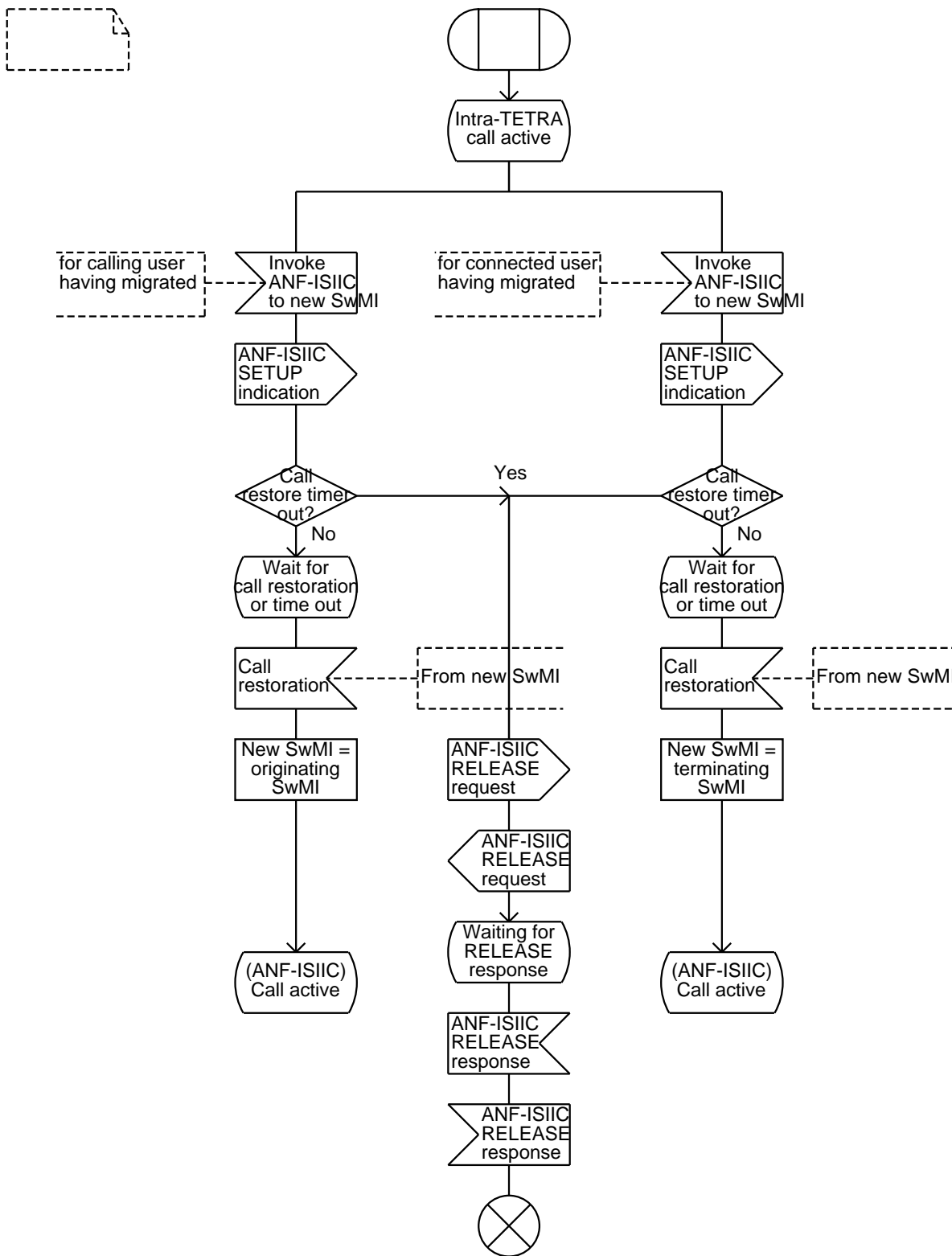

Figure 2 (sheet 5 of 5): ANF-ISIIC, overall SDL  
 Invocation of ANF-ISIIC because of migration  
 during an established intra-TETRA call

## 5 ANF-ISIIC stage 2 specification

### 5.1 Functional model

#### 5.1.1 Functional model description

The functional model shall comprise the following Functional Entities (FE):

- FE1 SwMI A individual call control application functional entity;
- FE1' New SwMI call restoring functional entity for migrating calling user;
- FE2 ISI individual call originating functional entity;
- FE2' ISI individual call new originating functional entity;
- FE3 ISI individual outgoing call route determining functional entity;
- FE4 ISI individual call migration handling functional entity;
- FE5 ISI migration information provision functional entity;
- FE6 ISI migrated called user routeing functional entity;
- FE7 ISI individual call terminating functional entity;
- FE7' ISI individual call new terminating functional entity;
- FE8 Terminating SwMI individual call control functional entity;
- FE8' New SwMI call restoring functional entity for migrating called user.

The following functional relationships shall exist between these FEs:

- ra between FE1 and FE2;
- rb between FE2 and FE3;
- rc between FE2 and FE4;
- rd between FE4 and FE5;
- re between FE4 and FE6;
- rf between FE6 and FE7;
- rg between FE2 and FE7;
- rh between FE7 and FE8;
- ri between FE1 and FE8;
- rj between FE2 and FE2';
- rk between FE1' and FE2' or between FE8' and FE7';
- rl between FE7 and FE7'.

Figure 3 shows these FEs and relationships in the case where the called user home SwMI is different from the originating SwMI (i.e. the called user home SwMI is SwMI B).

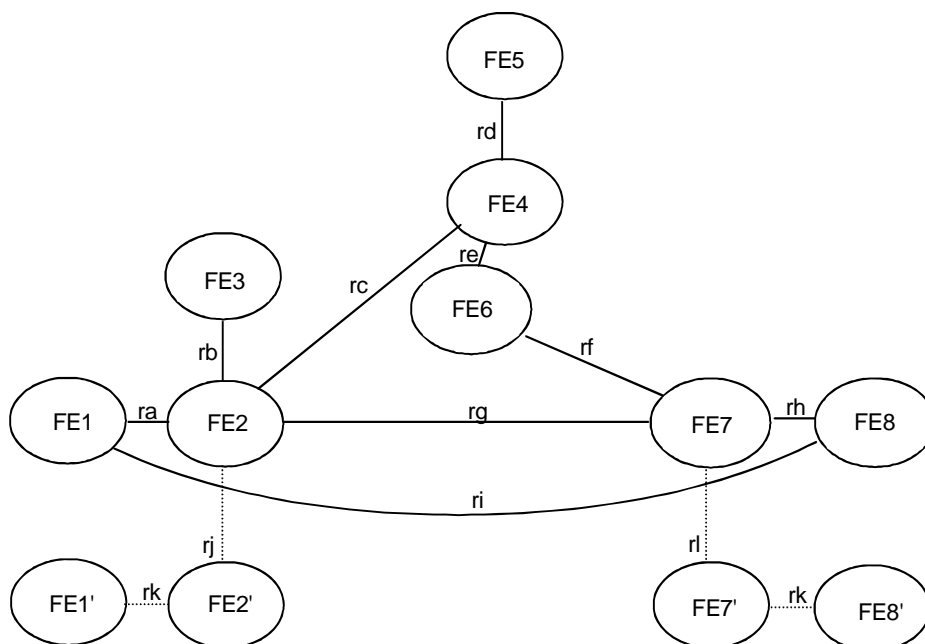

**Figure 3: Functional model for ANF-ISIIC  
when the called user home SwMI is different from the originating SwMI**

Figure 4 shows these FEs and relationships in the case where the called user home SwMI is the originating SwMI (i.e. the called user home SwMI is SwMI A).

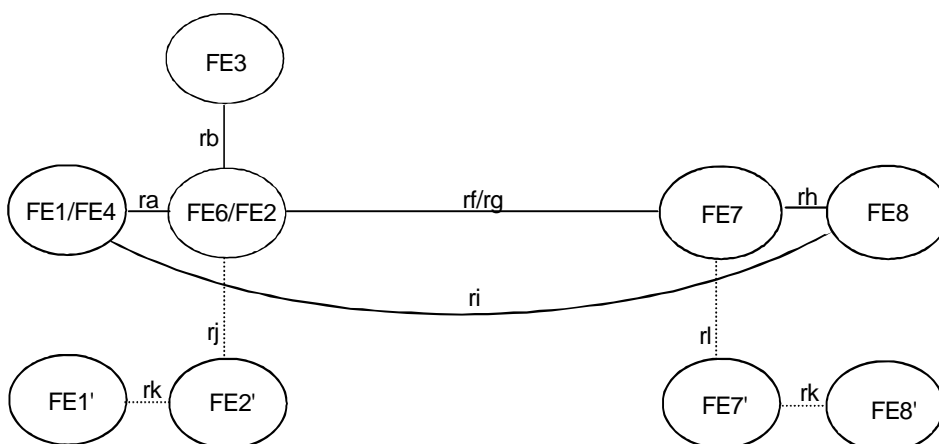

NOTE: Even though it is not a functional entity of ANF-ISIIC in this case (see clause 5.1.2.4), FE4 has been shown in figure 4 to avoid showing a direct relationship between FE1 and FE6.

**Figure 4: Functional model for ANF-ISIIC  
when the called user home SwMI is the originating SwMI**

## 5.1.2 Description of functional entities

### 5.1.2.1 SwMI A individual call control application functional entity, FE1

This functional entity invokes ANF-ISIIC when it receives a set-up information flow from a calling user (at its air interface) requesting the establishment of a call to another user which to its knowledge is registered in another TETRA network. It relays to the called user the call establishment response information flow(s) received from FE8 through FE7 and FE2 (and possibly FE6 and FE4). Once the call has been established, it ensures call maintenance (as defined in clause 14.1.2 of EN 300 392-2 [1]) for the calling user in exchanging related control information flows with FE8 for the necessary co-ordination.

If FE1 is informed by ANF-ISIMM that the calling user is now registered in another network (where the calling user would have migrated during the call), it shall request FE2 to establish a connection leg with FE1' through FE2', both newly created. After the call has been once transferred (following the call restoration request by the calling user) between FE1', in the other network, and FE8, FE1 shall be cleared, and FE1' shall then become the new FE1.

#### 5.1.2.2 ISI individual call originating functional entity, FE2

This functional entity ensures an ISI outgoing gateway function for individual calls from SwMI A call control application. This includes the following capabilities:

- the ability to establish an individual call upon request of FE1 and release it notably upon request of FE1;
- the ability to associate and mediate between FE1 and the subsequent PISN CC functional entity involved in a particular call and between FE1 and FE8, notably to transfer to FE8 any information received from FE1 (i.e. ISI end-to-end information), and vice versa;
- the ability, when the called user home SwMI is SwMI B and when this user has migrated to SwMI C, to decide, possibly on the basis of the information received from FE4, either to re-route the call over another ISI or to have it forward switched (in SwMI B);
- unless SwMI C coincides with SwMI A (i.e. the called user has migrated in the same SwMI as the originating one and the CC entity of the latter was not capable of identifying this), in which case FE2 shall ensure the interactions with local SS-BIC, SS-CAD and SS-CF if activated for intra-TETRA calls (in SwMI A), taking into account the information received from FE4 regarding the activation of those supplementary services also for the called user but in his home SwMI. If the call is not forwarded, FE2 shall clear the invoked ANF-ISIIC, with or without clearing the call, depending on whether or not the call is barred by the above mentioned incoming call restriction supplementary services.

Upon request from FE1 (to prepare for call restoration), FE2 shall establish a connection leg with FE1' through FE2', both newly created. Once informed by FE1' that the calling user has requested call restoration, FE2 shall ensure the transfer of the call between FE1' through FE2' and FE8. FE2' shall then become the new FE2.

#### 5.1.2.3 ISI individual outgoing call route determining functional entity, FE3

This functional entity:

- provides to FE2, or FE6 in the case where the called user home SwMI is the originating SwMI, information to route the individual call (over the ISI) to SwMI B;
- provides to FE2 information about activations and "definitions" (the latter term corresponding to the term "registrations" as defined in ITU-T Recommendation I.130 [i.5]) of local SS-BIC, SS-CAD and SS-CF.

#### 5.1.2.4 ISI individual call migration handling functional entity, FE4

This functional entity ensures the handling of individual calls incoming from FE2 when the home SwMI of the called user is SwMI B. This includes the following capabilities:

- the ability to operate as a Private Integrated Services Network Exchange (PINX) node incoming side;
- the ability to ensure the interactions with the supplementary services SS-BIC, SS-CAD and SS-CF if activated for the called user, the first two, to restrict his incoming calls, and the last one, to forward his calls. Notably FE4 shall ensure together with FE2 the specific interactions which apply in the case where the called user has migrated in the originating SwMI (i.e. SwMI C coincides with SwMI A);
- the ability, if the called user has migrated, to indicate to FE2:
  - in which SwMI the called user is registered now (i.e. SwMI C), on the basis of the information received from FE5;
  - whether or not forward switching is possible;
  - to detect whether SwMI C coincides with SwMI A; and

- the ability, if FE2 requests FE4 to forward switch the call, to operate as the incoming side of a transit PINX (the outgoing side of which is ensured by FE6).

When the called user home SwMI is SwMI A (i.e. this user has migrated and is now registered in SwMI B), FE4 will coincide with FE1 (i.e. as part of SwMI A call control application and not of ANF-ISIIC). This is because first any interaction with SS-BIC, SS-CAD or SS-CF activated for the called user shall then be ensured by SwMI A supplementary service control applications, and not by ANF-ISIIC; and second, SwMI A call control application has to know that the called user has migrated and where it is currently registered (i.e. SwMI B) to invoke ANF-ISIIC to extend the call.

#### 5.1.2.5 ISI information provision functional entity, FE5

This functional entity:

- provides information to FE4 about activations and "definitions" (the latter term corresponding to the term "registrations" as defined in ITU-T Recommendation I.130 [i.5]) of general SS-BIC, SS-CAD and SS-CF;
- if the called user has migrated to TETRA network C, provides this information to FE4.

#### 5.1.2.6 ISI individual call migrated called user routeing functional entity, FE6

This functional entity ensures the routeing of individual calls to called users which have migrated. When the called user home SwMI is different from the originating SwMI, depending on FE2 decision and possibly on its own decision, either FE6 shall be located in SwMI A, and the call shall then be re-routed (from SwMI A), or FE6 shall be located in SwMI B, and the call shall then be forward switched (by SwMI B). FE6 includes the following capabilities:

- for re-routeing the call, the ability to supplement FE2 in sending a set-up information flow to FE7 after having got the necessary routeing information to route the call (over the ISI) to SwMI C;
- for forward switching the call, the ability to operate as the outgoing side of a transit PINX, the incoming side of which is ensured by FE4. As in the case of re-routeing, that ability implies to have got the necessary routeing information to route the call (over the ISI) to SwMI C.

When the called user home SwMI is the originating SwMI (see clause 5.1.2.4), FE6 shall replace FE2 to establish the call.

#### 5.1.2.7 ISI individual call terminating functional entity, FE7

This functional entity ensures an ISI incoming gateway function for individual calls towards FE8. This includes the following capabilities:

- the ability to establish an individual call to FE8 upon request of FE6 and release it notably upon request of FE8;
- the ability to associate and mediate between FE8 and the subsequent PISN CC functional entity involved in a particular call and between FE8 and FE1, notably to transfer to FE1 any information received from FE8 (i.e. end-to-end information), and vice versa.

When FE6 does not exist, FE7 shall be collocated with FE4.

NOTE: According to clause 5.1.2.6, FE6 does not exist when the called user is registered in its home SwMI (which implies, since an ANF-ISIIC has been invoked, that this called user home SwMI is SwMI B).

Upon request from FE8 (to prepare for call restoration), FE7 shall establish a connection leg with FE8' through FE7', both newly created. Once informed by FE8' that the connected user has requested call restoration, FE7 shall ensure the transfer of the call between FE8' through FE7', and FE1. FE7' shall then become the new FE7.



### 5.1.2.8 Terminating SwMI call control functional entity, FE8

This functional entity ensures the establishment of the call to the called user according to the invoked ANF-ISIIC set-up information flow. It informs FE1 through FE7 and FE2 (and possibly FE6 and FE4) about the completion (or failure) of this call establishment. Once the call has been established, it ensures call maintenance (as defined in clause 14.1.2 of EN 300 392-2 [1]) for the connected user, exchanging related control information flows with FE1 for the necessary co-ordination.

If FE8 is informed by ANF-ISIMM that the connected user is now registered in another network (where this user would have migrated during the call), it shall request FE7 to establish a connection leg with FE8' through FE7', both newly created. After the call has been transferred (following the call restoration request by the connected user) between FE8', in the other network, and FE1, FE8 shall be cleared, and FE8' shall become the new FE8.

### 5.1.3 Relationship of functional model to basic call functional model

By definition, an invoked ANF-ISIIC establishes a PISN basic call. As a result its functional model matches closely that of PISN basic call (as defined in ISO/IEC 11574 [10]):

- FE1 shall be collocated with the originating PISN CC;
- FE2 shall also be collocated with the originating PISN CC (i.e. in SwMI A ANF-ISIIC outgoing gateway - gateway which may be virtual);
- FE4 together with FE6 shall be collocated in a transit PISN CC in the case of forward switching;
- FE7 shall be collocated with the terminating PISN CC (i.e. in the ANF-ISIIC incoming gateway of terminating SwMI - gateway which may be virtual);
- FE8 shall also be collocated with the terminating PISN CC.

Figures 5, 6, 7 and 8 show examples of the relationship between the two models in the cases:

- where the home SwMI of the called user is SwMI B and where this user is registered in its home SwMI, for figure 5;
- where the home SwMI of the called user is SwMI A (and where this user is registered in SwMI B), for figure 6;
- where the called user has migrated (to SwMI C), and the call has been forward switched (in SwMI B), for figure 7;
- where the called user has migrated (to SwMI C), and the call has been re-routed (in SwMI A), for figure 8.



**Figure 5: Example relationship between models for ANF-ISIIC and basic call in the case of called user hSwMI being SwMI B, with no migration**



**Figure 6: Example relationship between models for ANF-ISIIC and basic call in the case of called user hSwMI being SwMI A**

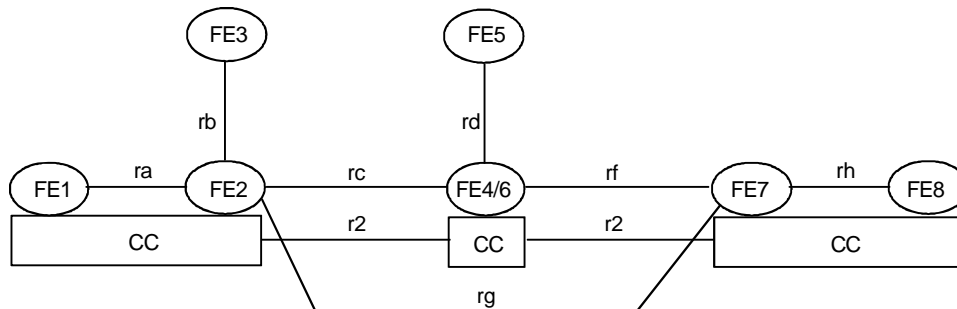

**Figure 7: Example relationship between models for ANF-ISIIC and basic call in the case of forward switching**

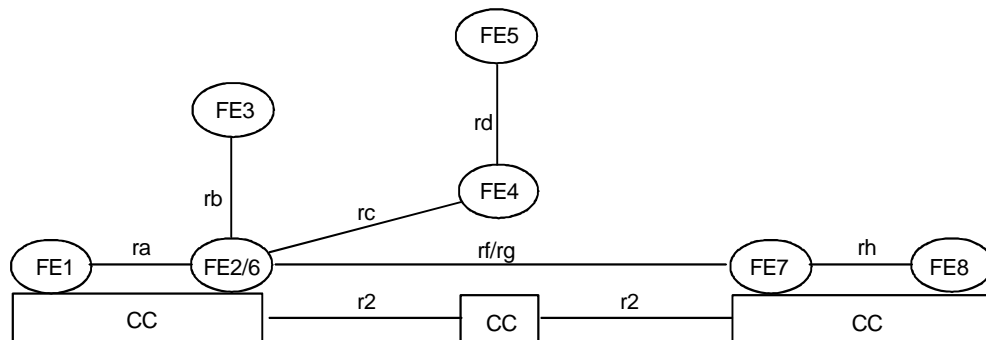

**Figure 8: Example relationship between models for ANF-ISIIC and basic call in the case of re-routeing**

## 5.2 Information flow

### 5.2.1 Examples of information flow sequences

The stage 3 description of ANF-ISIIC provides signalling procedures in support of the information flow sequences specified below.

The figures have been drawn as Message Sequence Charts (MSC) using a drafting tool. Due to the limitations of that tool, it has not been possible to show the stage 1 primitives (shown on stage 1 overall SDL, in figure 2) nor to represent ANF-ISIIC information flows independently from basic call (i.e. PISN basic call) information flows (e.g. with an ellipse embracing one ANF-ISIIC and one PISN basic call information flows to indicate that the two information flows occur simultaneously, or having an ANF-ISIIC information flow between two functional entities which are not adjacent - e.g. end-to-end, while the PISN basic call information flows are always between two adjacent functional entities). Simply when an ANF-ISIIC information flow occurs together with a PISN basic call information flow, the name of the latter is shown below the corresponding arrow, and the originating and the terminating functional entities of the arrow are those of the ANF-ISIIC information flow.

NOTE 1: The names used for the PISN basic call information flows are those defined in ISO/IEC 11574 [10], on the stage 1 and 2 description of PISN basic call. And whenever possible (i.e. when such primitives exist), the names which have been given to the ANF-ISIIC information flows are those of the corresponding TNCC primitives, as defined in clause 11 of EN 300 392-2 [1]. For that reason e.g. information flow COMPLETE is unique to the stage 2, in stage 3 the corresponding information it transported in the TETRA application ISI-CONNECT PDU.

NOTE 2: Stage 2 information flows for the basic call contents are used as a starting point in standardisation for TETRA application, but the contents of ISI PDUs as defined in stage 3 are not presented in the state 2 information flows. The stage 3 PDUs and which of the basic call PDUs are used to carry them should be studied with the stage 2 information flows to get a full picture of the TETRA application behaviour.

The following abbreviations are used:

- req request.
- ind indication.
- resp response.
- conf confirmation.

#### 5.2.1.1 Successful call set-up when the called user is registered in SwMI B and uses on/off hook signalling

Figure 9 shows the information flow sequence for ANF-ISIIC call set-up when the called user uses on/off hook signalling and when its home SwMI is SwMI B and it has not migrated.

The information flow sequence corresponding to the case where the called user home SwMI is SwMI A (and this user has migrated and is registered in SwMI B) can be derived from figure 9 in replacing FE2 by FE6/FE2, and FE4/FE7 by FE7.

# MSC Successful\_call\_set\_up\_on\_off\_hook\_no\_migr

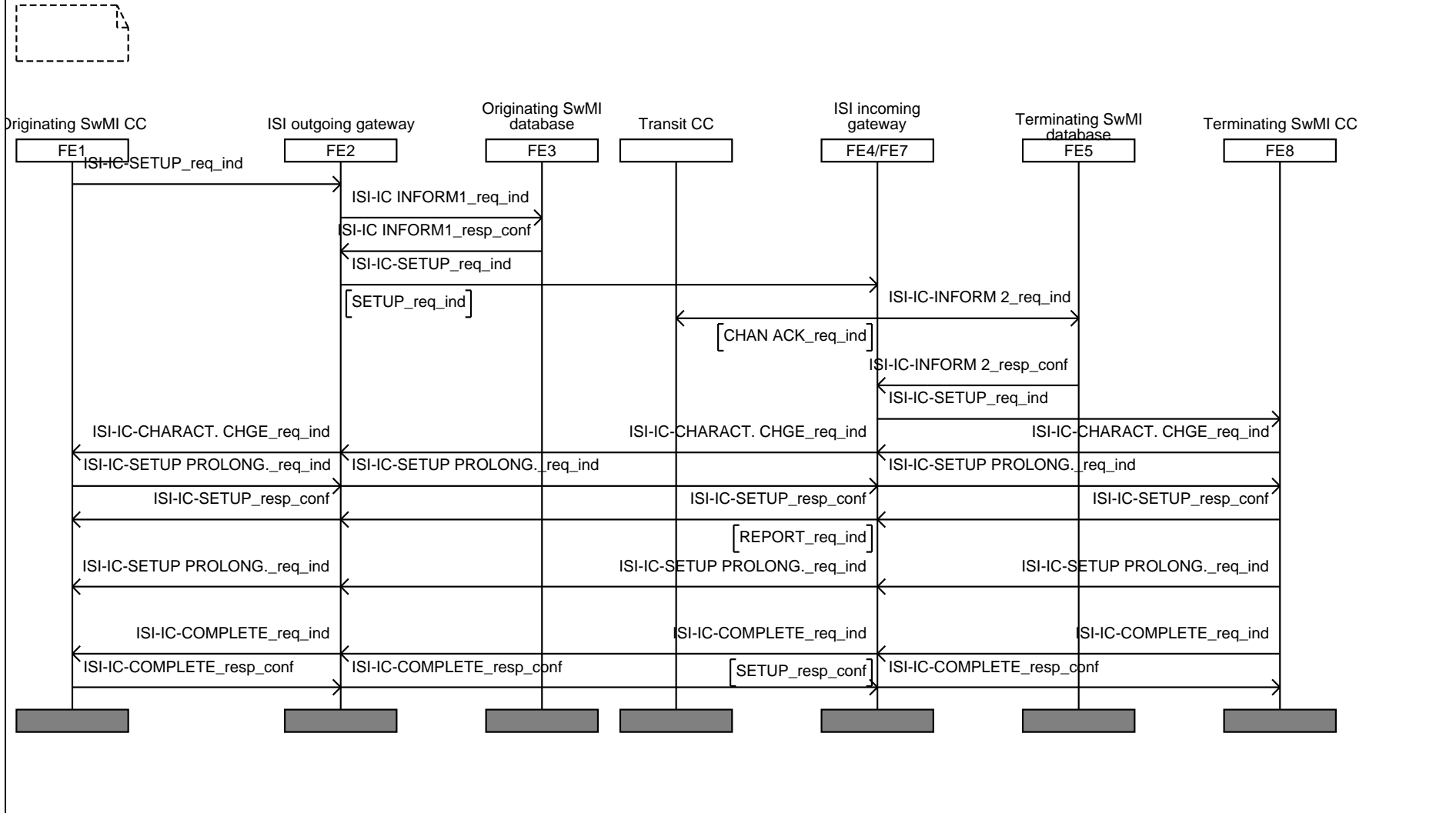

NOTE: The ISI-IC-SETUP PROLONGATION and -CHARACTERISTIC CHANGE request/indication information flows shown on the figure are optional.

**Figure 9: Information flow sequence - successful call set-up using on/off hook signalling**

### 5.2.1.2 Successful call set-up when the called user is registered in SwMI B and uses direct set-up signalling

Figure 10 shows the information flow sequence for ANF-ISIIC call set-up when the called user uses direct set-up signalling and when its home SwMI is SwMI B and it has not migrated.

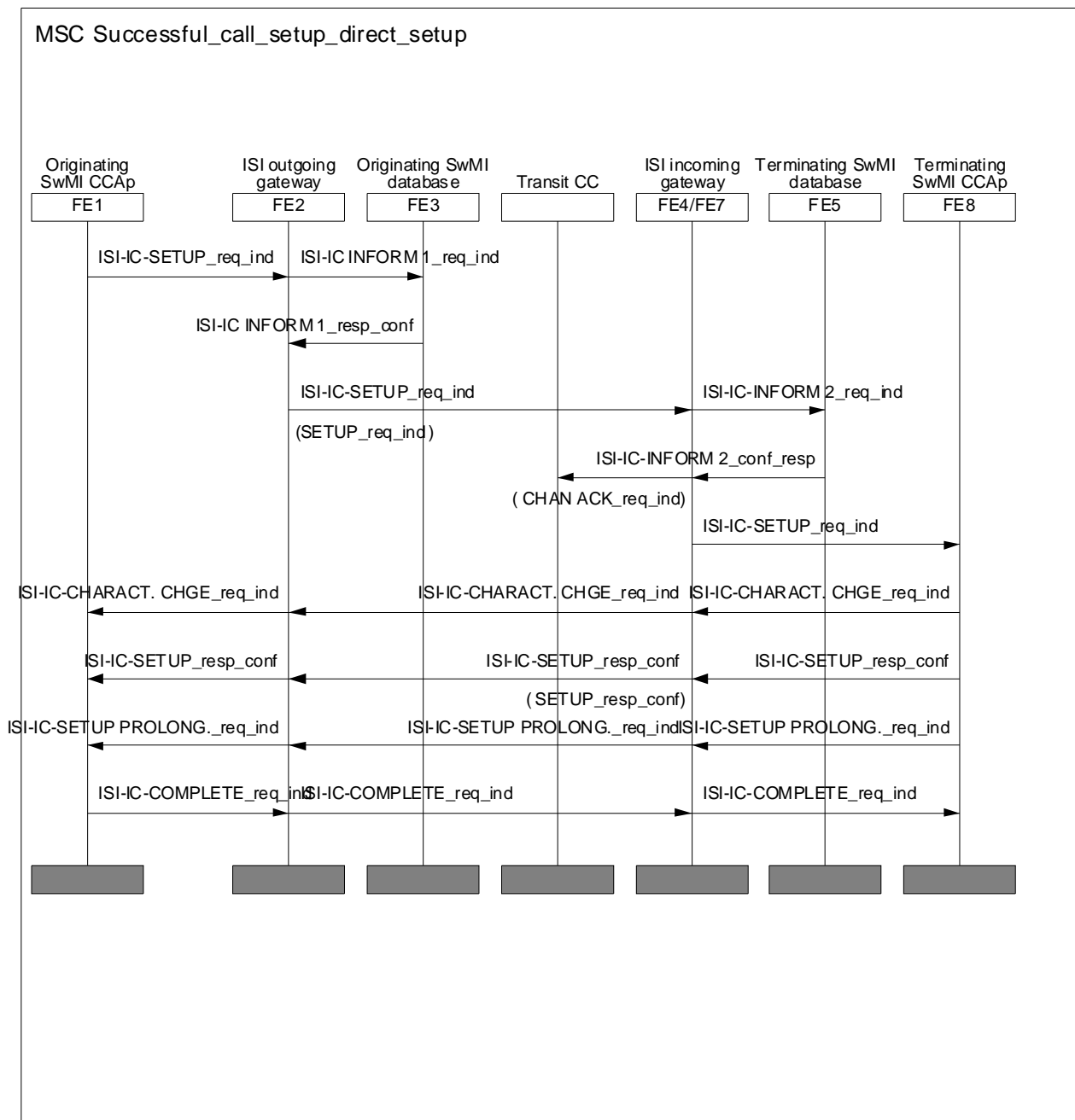

**Figure 10: Information flow sequence - successful call set-up using direct set-up signalling**

The information flow sequence corresponding to the case where the called user home SwMI is SwMI A (and this user has migrated and is registered in SwMI B) can be derived from figure 10 in replacing FE2 by FE6/FE2, and FE4/FE7 by FE7.

### 5.2.1.3 ANF-ISIIC set-up to a called user having migrated from SwMI B, using forward switching

Figure 11 shows the beginning of the information flow sequence for ANF-ISIIC call set-up when the called user has migrated from SwMI B, its home SwMI, and when SwMI A has indicated in the rb\_SETUP request/indication information flow that it wants to choose the routing method in case of migration of the called user, and decides to have the call forward switched (in SwMI B) as a result of the indication in the rb\_MIGRATION INFO request indication information flow.

### 5.2.1.4 ANF-ISIIC set-up to a called user having migrated from SwMI B, using re-routing

Figure 12 shows the beginning of the information flow sequence for ANF-ISIIC call set-up when the called user has migrated from SwMI B, its home SwMI, and when SwMI A has indicated in the rb\_SETUP request/indication information flow that it wants to choose the routing method in case of migration of the called user, and decides to re-route the call as a result of the indication in the rb\_MIGRATION INFO request indication information flow.

# MSC Successful\_call\_setup\_migration\_forward\_switching

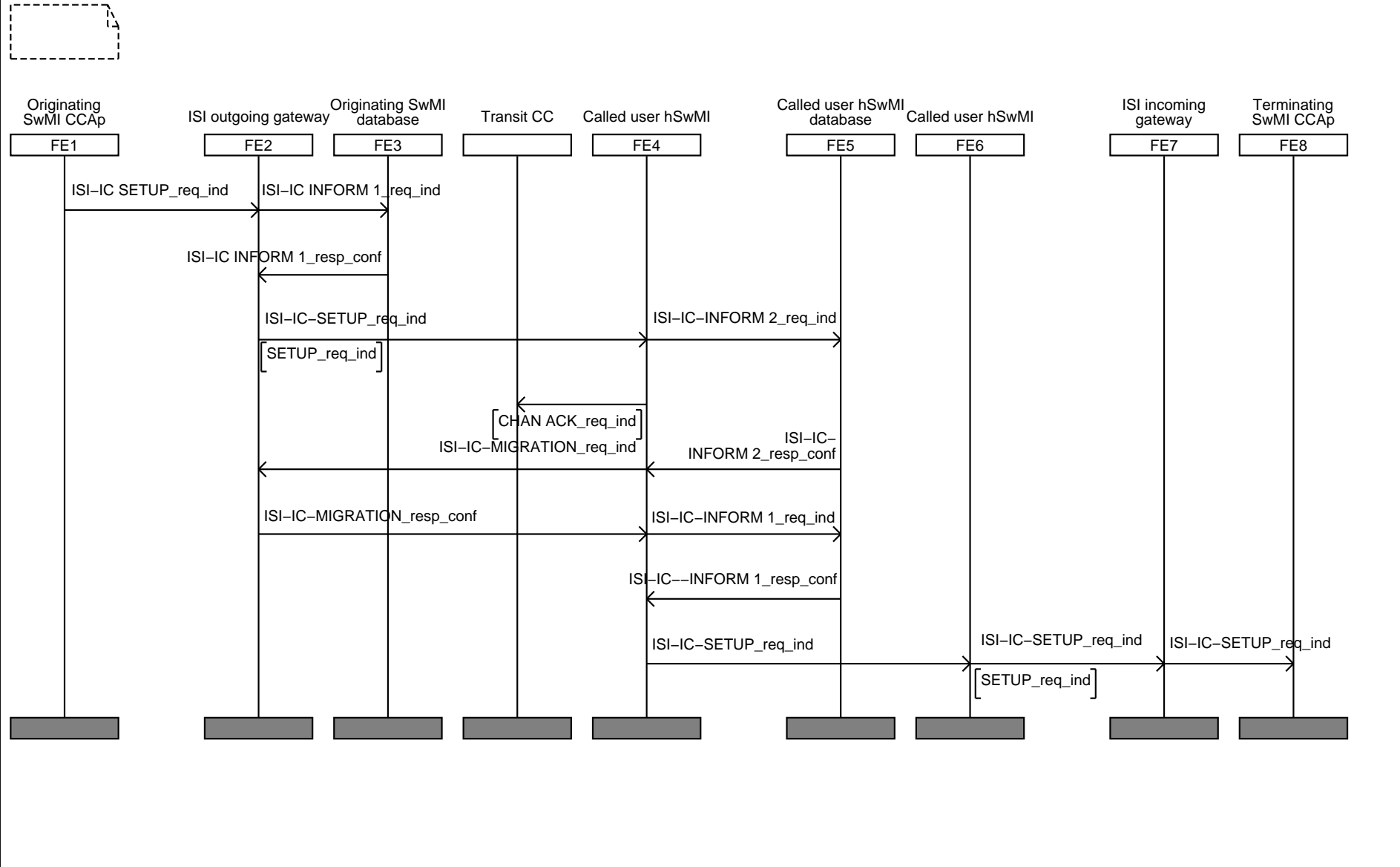

Figure 11: Information flow sequence - call set-up to a called user having migrated from SwMI B, using forward switching

# MSC Successful\_call\_setup\_migration\_rerouteing

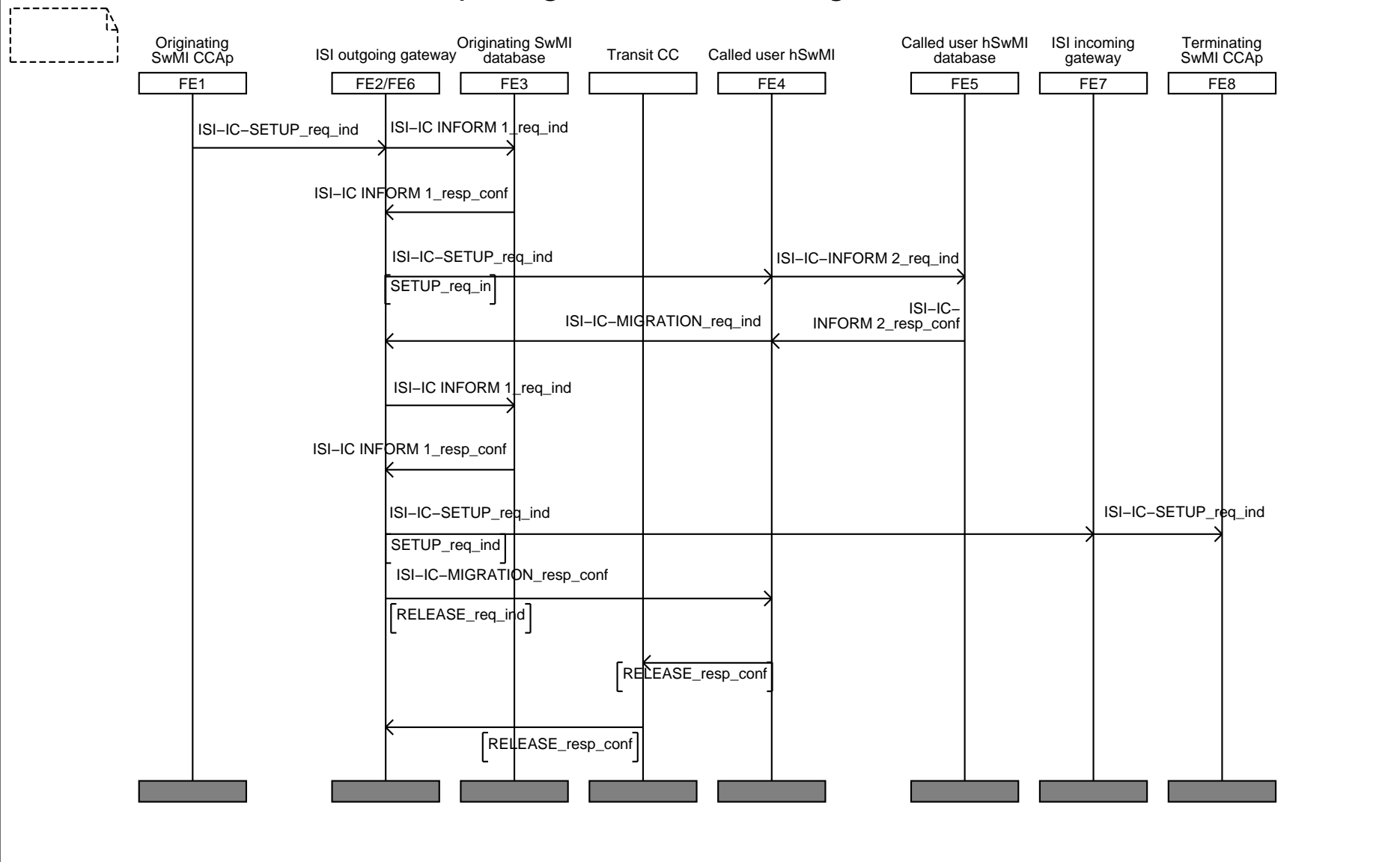

Figure 12: Information flow sequence - call set-up to a called user having migrated from SwMI B, using re-routing



5.2.1.5 Loop avoidance in case of intra-TETRA call

Figure 13 shows the information flow sequence when the home SwMI of the called user is SwMI B and when this user is registered in the originating SwMI, after having migrated. The invoked ANF-ISIIC is then cleared, and the information passed to SwMI A to continue the call as an intra-TETRA call.

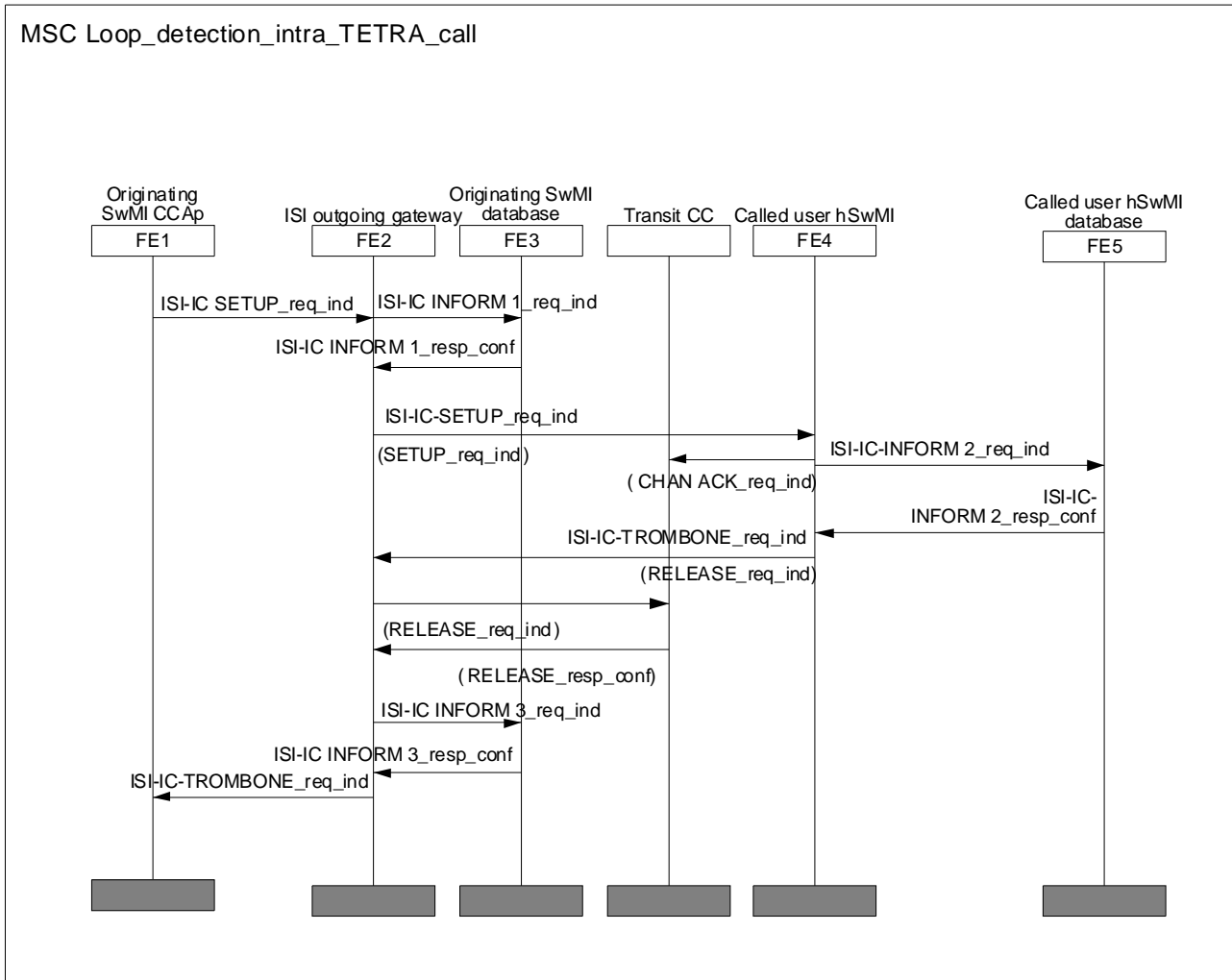
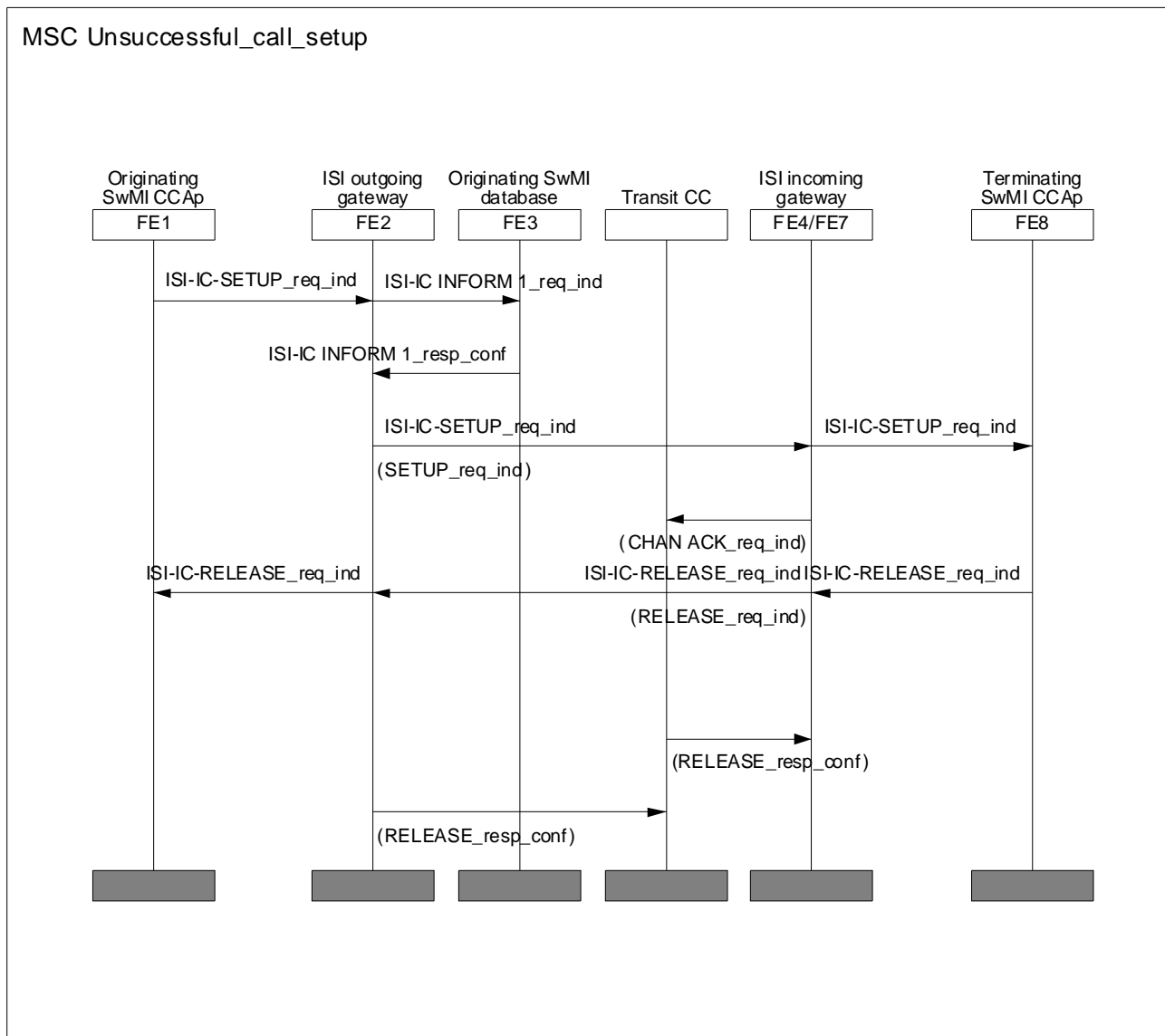

Figure 13: Information flow sequence - loop avoidance in case of intra-TETRA call

### 5.2.1.6 Unsuccessful ANF-ISIIC call set-up

Figure 14 shows the information flow sequence for an unsuccessful ANF-ISIIC call set-up when the call attempt is rejected either by the terminating SwMI CC entity or by the called user.



NOTE: The call set-up may also be rejected directly by the called SwMI, e.g. when it cannot match the air interface security level requested for the call. The corresponding information flow sequence has not been shown because it can easily be derived from figure 15.

**Figure 14: Information flow sequence - call rejected by the terminating SwMI or by the called user**

Figure 15 shows the information flow sequence for an ANF-ISIIC call set-up rejected by the called SwMI (i.e. SwMI B) as a result of the information provided by FE5.

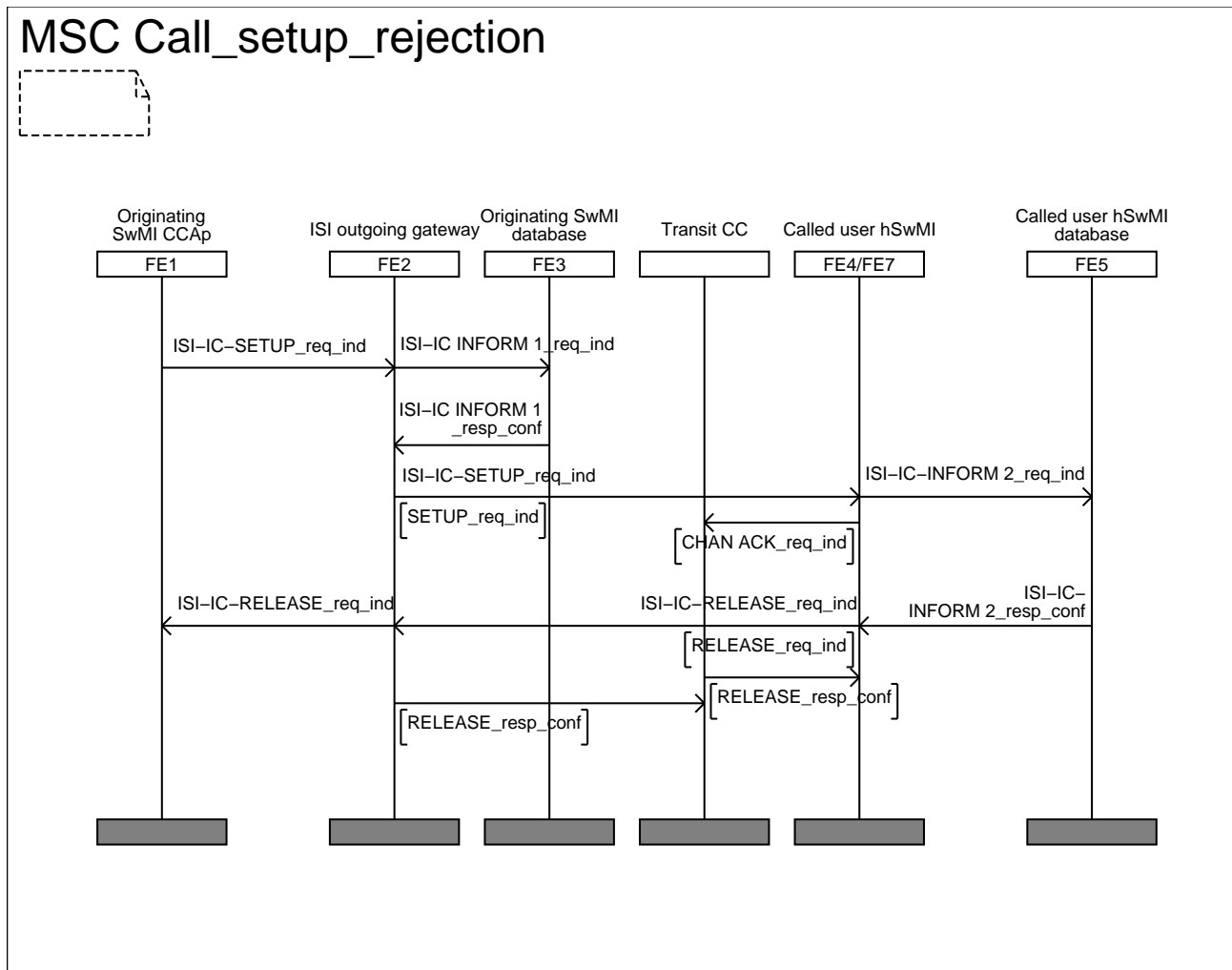

**NOTE:** In line with ISO/IEC 11574 [10], on the stages 1 and 2 descriptions of PISN basic call, the RELEASE information flows have been shown as confirmed information flows on this figure. However, the corresponding PSS1 protocol may operate differently: notably if the call is rejected before a PSS1 responding message has been sent, the PSS1 RELEASE request shall not be acknowledged (this corresponds to the ANF-ISIIC incoming gateway having rejected the call set-up with a PISN message RELEASE COMPLETE - see clause 10.2 of ISO/IEC 11572 [9]).

**Figure 15: Information flow sequence - call rejected by the called SwMI**

### 5.2.1.7 Transmission control

Figure 16 shows the information flow sequence for half-duplex operation, when the called user requests to transmit.

## MSC Half\_duplex\_operation

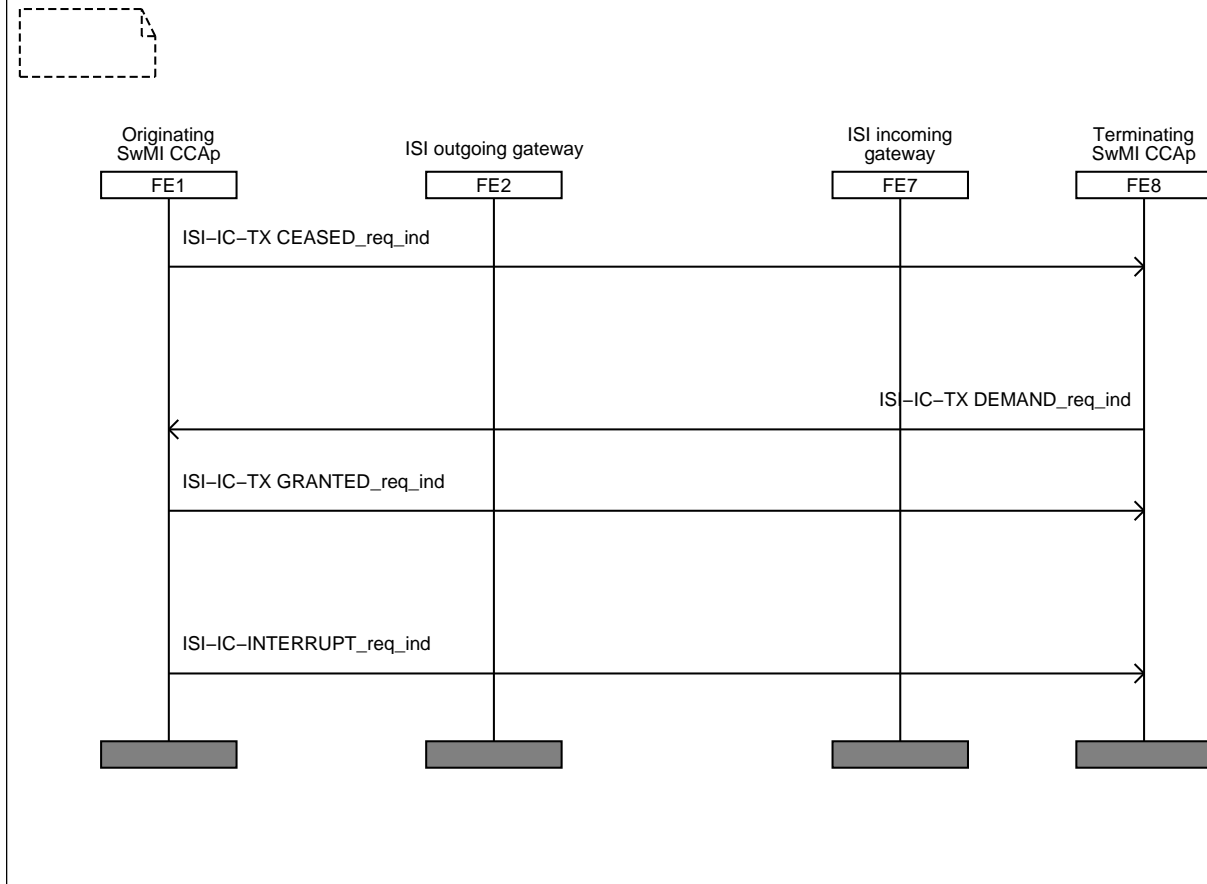

NOTE: All information flows which shown in figure 16 are across relationship ri, i.e. end-to-end between FE1 and FE8.

**Figure 16: Information flow sequence - half-duplex operation with the called user requesting to transmit**

### 5.2.1.8 Call modify

Figure 17 shows the information flow sequence for call modification, when the modification request comes from the originating SwMI.

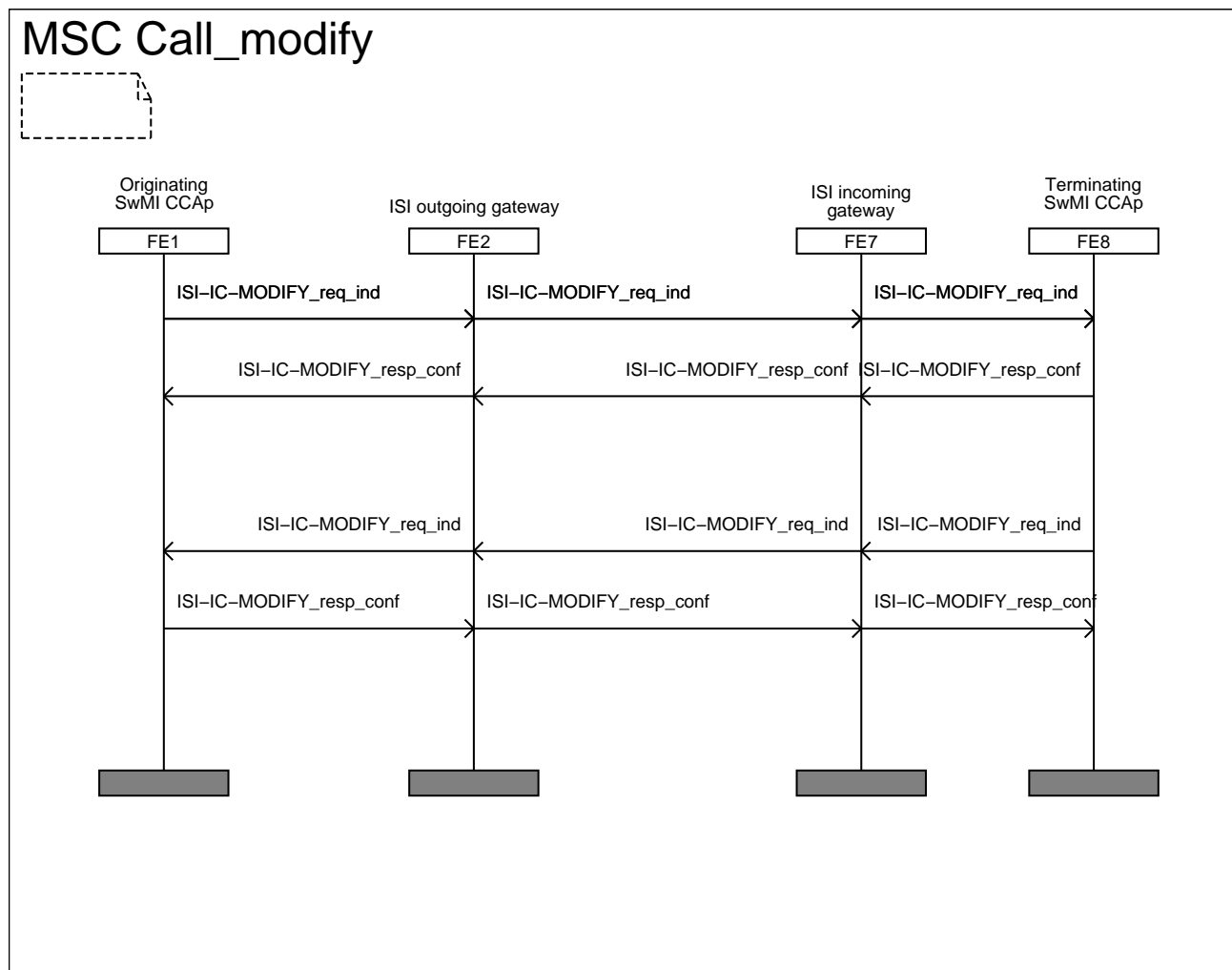

**NOTE:** The MODIFY information flows are not end-to-end between the originating and the terminating SwMI because they may result in a change in the 8 kbit/s encoding of the user information at the ISI, i.e. if the circuit mode service is modified, i.e. from speech to data service or vice-versa, or if the circuit mode service being data service, this service is changed, e.g. from 7,2 kbit/s to 4,8 kbit/s.

**Figure 17: Information flow sequence - call modification**

5.2.1.9 Call restoration after migration

Figure 18 shows the information flow sequence for call restoration in a new SwMI.

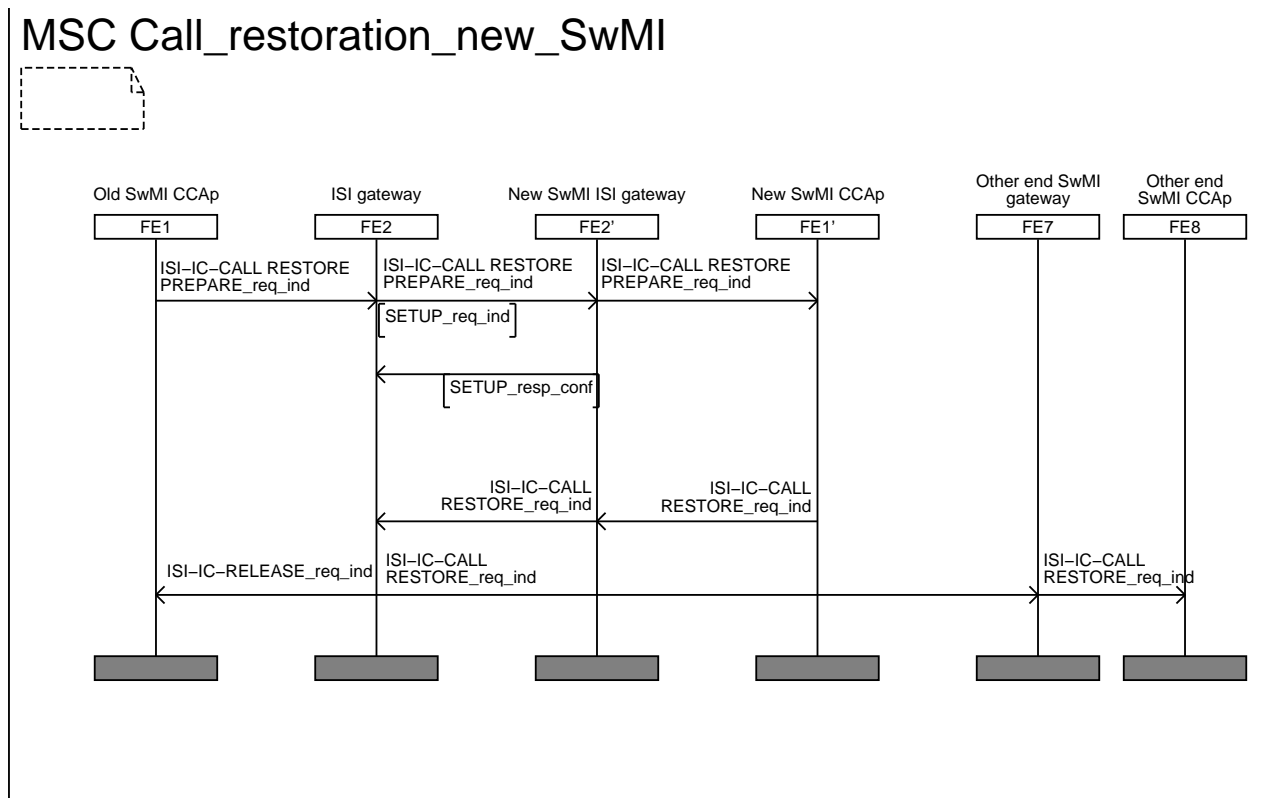

Figure 18: Information flow sequence - call restoration of an established inter-TETRA call in a new SwMI

Figure 19 shows the information flow sequence for call restoration in the forward switching SwMI.

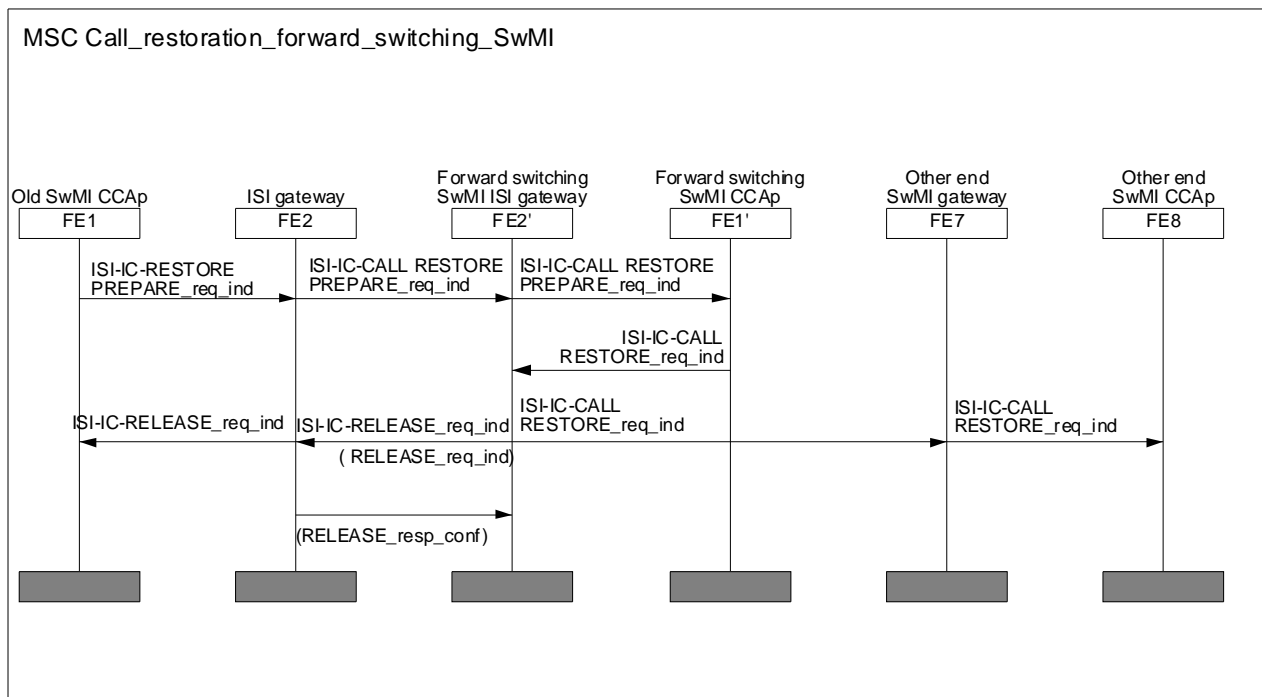
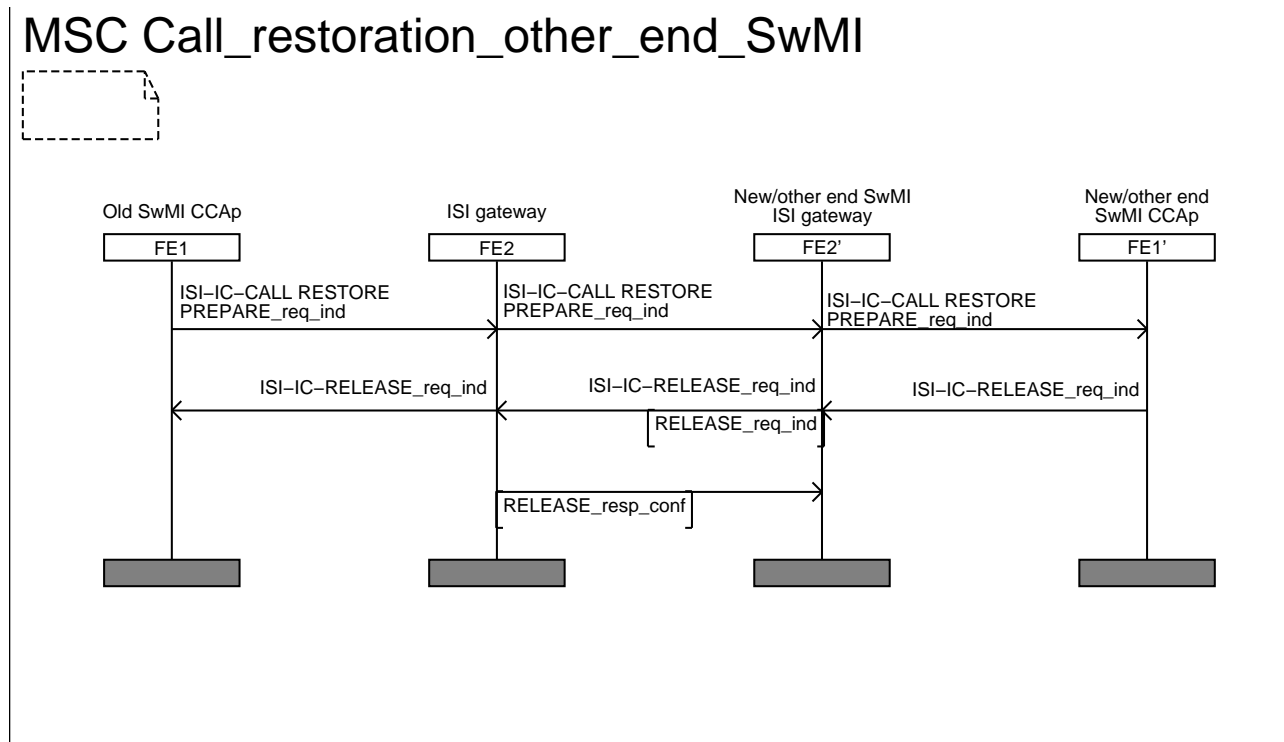

Figure 19: Information flow sequence - call restoration of an established inter-TETRA call in the forward switching SwMI

Figure 20 shows the information flow sequence for call restoration in the other end SwMI.



**Figure 20: Information flow sequence - call restoration of an established inter-TETRA call in the other end SwMI**

Figure 21 shows the information flow sequence for call restoration of an intra-TETRA call in another SwMI.

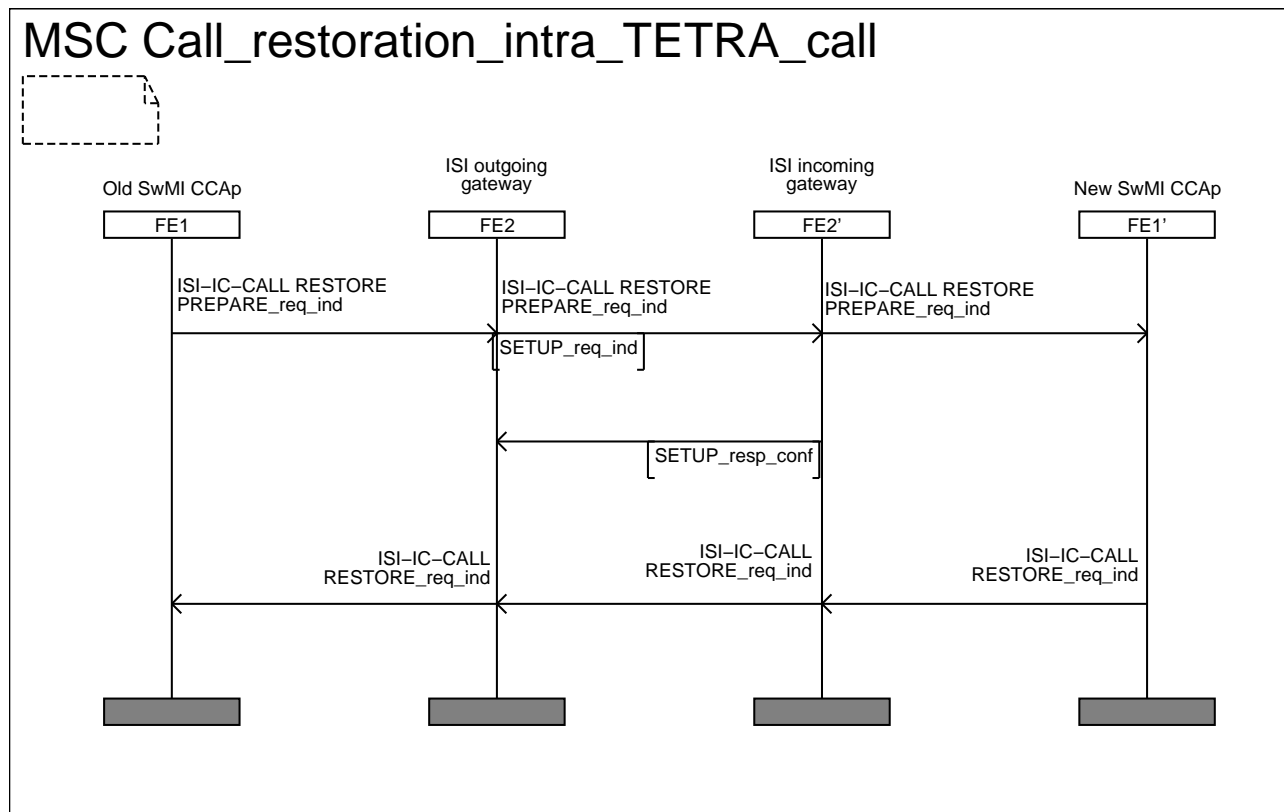

**Figure 21: Information flow sequence - call restoration of an established intra-TETRA call**

### 5.2.1.10 Call clearing

Figure 22 shows the information flow sequence when a call is cleared by its calling user. A symmetrical sequence applies when a call is cleared by its called user.

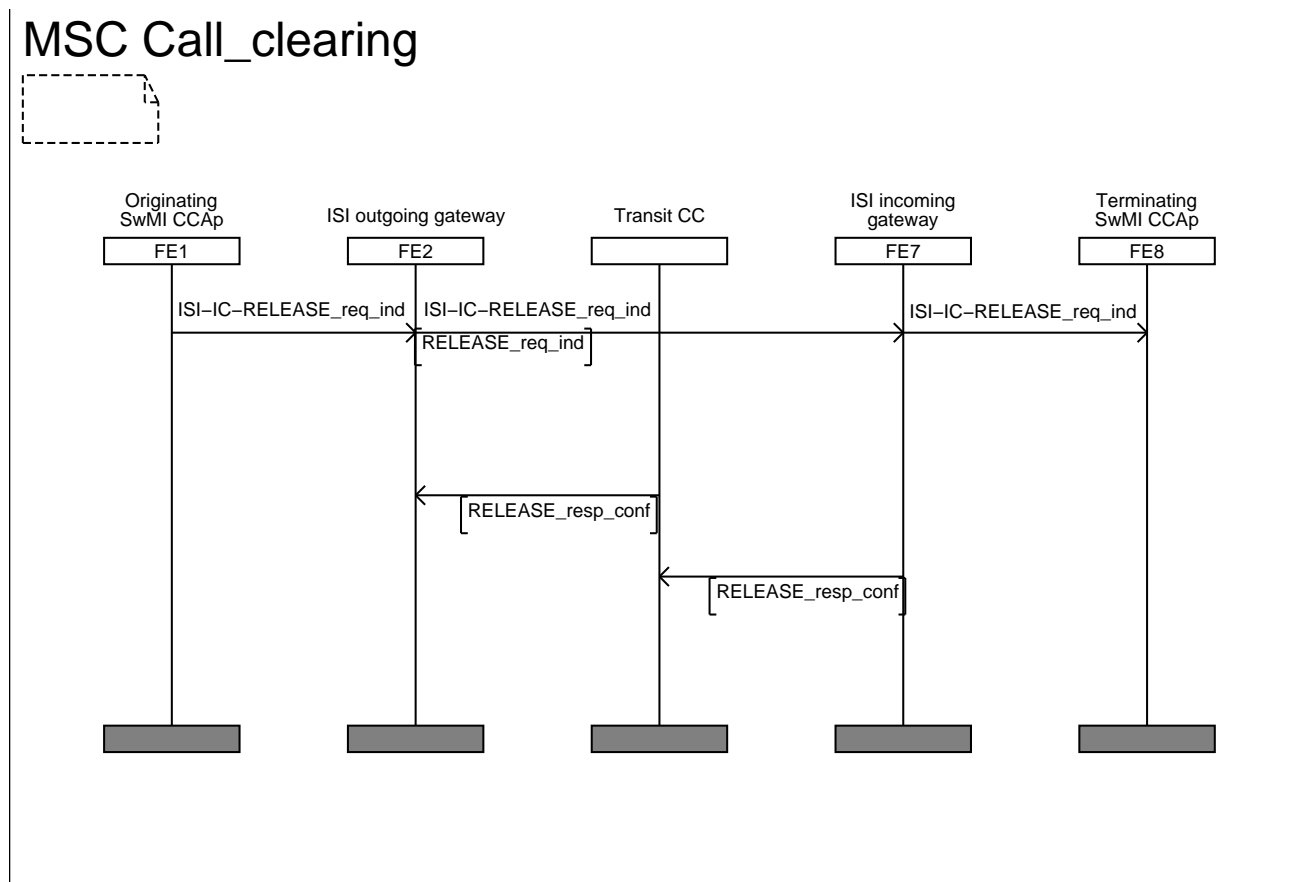

**Figure 22: Information flow sequence - call clearing**

### 5.2.1.11 Radio traffic channel resource queuing and allocation

The call is connected (ISI-CONNECT PDU) by the terminating SwMI immediately when the air interface U\_CONNECT PDU is received. This allows the originating SwMI, in a late assignment call, to attempt to obtain its radio traffic channel resources at virtually the same time as in the terminating SwMI. Should there be no queuing for radio traffic channel resources in either of the SwMIs then the call is connected by the originating SwMI (ISI-CONNECT-ACKNOWLEDGE PDU) and the call then enters its maintenance phase. If there is any queuing for radio traffic channel resources then extra signalling is involved before the call can enter its maintenance state. The extra signalling takes account of the different radio traffic channel allocation policies that each SwMI may be using and the need to keep each SwMI immediately aware of the queuing state of the call.

If there is any queuing for radio traffic channel resources, in either SwMI, when the terminating SwMI connects the call (ISI-CONNECT PDU) then the originating SwMI indicates this to the terminating SwMI (ISI-QUEUING PDU). If the terminating SwMI did not have its radio traffic channel resources immediately available when it connected the call (ISI-CONNECT PDU) then when they do become available it passes this status information to the originating SwMI (ISI-RESOURCE-RESPONSE PDU).

The originating SwMI has to decide, based on the availability of radio traffic channels, if it should either finally connect the call, because both SwMIs have their radio traffic channel resources (ISI-CONNECT-ACKNOWLEDGE), or further delay the call, because one or either of them do not (ISI-QUEUING). This can happen when a radio traffic channel becomes available locally or when the terminating SwMI indicates that it has a radio traffic channel available (ISI-RESOURCE-RESPONSE).



Because a terminating SwMI may be operating a policy of temporary resource allocation during call setup, the originating SwMI (which has to control when the call is connected) may optionally support the use of the ISI-RESOURCE PDU to request the state of the terminating SwMI's radio traffic channel allocation and, if it not currently allocated, request it to be allocated. The originating SwMI will send the ISI-RESOURCE PDU when it has an opportunity to connect the call (i.e. it has its radio traffic channel available) and needs to check if the terminating SwMI is also in a state where the call can be connected. The response of the terminating SwMI is either to immediately indicate that it has the resources it needs (ISI-RESOURCE-RESPONSE PDU) or firstly indicate that it does not immediately have its resources, and then later indicate when it does (both carried in ISI-RESOURCE-RESPONSE PDUs).

The resource allocation policy of the terminating SwMI is indicated to the originating SwMI when the terminating SwMI connects (ISI-CONNECT PDU). The support of the extra signalling (ISI-RESOURCE PDU) that may be needed to support this allocation policy is indicated to the terminating SwMI when the originating SwMI first delays the call (ISI-QUEUING PDU).

## 5.2.2 Definition of information flows

In the tables listing the service elements in information flows, the column headed "Request" indicates which of these service elements are Mandatory (M) and which are Optional (O) in a request/indication information flow, and the column headed "Confirm" indicates which of these service elements are Mandatory (M) and which are Optional (O) in a response/confirmation information flow.

### 5.2.2.1 CALL RESTORE

CALL RESTORE is an unconfirmed information flow across the following relationships:

- rk from FE1' to FE2', rj from FE2' to FE2, rg from FE2 to FE7 and rh from FE7 to FE8, if the user restoring the call is the calling user;
- rk from FE8' to FE7' rl from FE7' to FE7, rg from FE7 to FE2 and ra from FE2 to FE1, if the user restoring the call is the connected user.

It informs the SwMI where the user was previously registered that it is not going to be anymore an end SwMI and that it should take the actions specified for call restoration (e.g. in the general case: joining the leg with the new SwMI and the existing ISI call path with the other end SwMI).

It also informs the SwMI at the other end about the call restoration, with possible call modifications proposed by the new SwMI.

Table 3 lists the service elements within the CALL RESTORE information flow.

**Table 3: Contents of CALL RESTORE**

Service element	Request
New SwMI MNI	M
Simplex/duplex selection	M
Call priority	M
Basic service information	M
Transmission request permission	O (see note)
Transmission grant	O (see note)
Call status	O
NOTE:	Mandatory if this information flow is sent by FE1' (corresponding to controlling SwMI). Not to be included if this information flow is sent by FE8'.

### 5.2.2.2 CALL RESTORE PREPARE

CALL RESTORE PREPARE is an unconfirmed information flow across the following relationships:

- ra from FE1 to FE2, rj from FE2 to FE2' and rk from FE2' to FE1', if the user restoring the call is the calling user;
- rh from FE8 to FE7, rl from FE7 to FE7' and rk from FE7' to FE8', if the user restoring the call is the connected user.

It informs the SwMI where the user is now registered to prepare for call restoration.

**NOTE:** Although formally CALL RESTORE PREPARE is an unconfirmed information flow, it is actually confirmed when the call restoration has been successful:

- by the CALL RESTORE request/indication information flow, in the general case where the call restoration takes place in a SwMI different from those on the path of the call (i.e. FE1' is not collocated with FE8 nor located in a SwMI through which the call has been forward switched, or FE8' is not collocated with FE1 nor located in a SwMI through which the call has been forward switched);
- by the PISN basic call RELEASE request/indication information flow in the specific cases where the call restoration takes place in a SwMI on the path of the call, including the end SwMIs (originating and terminating SwMIs).

The case where the call restoration has not been successful can only be detected by the expiry of a timer for the reception of the information flows mentioned above in the cases of successful call restoration.

Table 4 lists the service elements within the CALL RESTORE PREPARE information flow.

**Table 4: Contents of CALL RESTORE PREPARE information flow**

Service element	Request
Other end SwMI MNI	M
Basic service information	M
Speech services supported	O (see note 1)
Security level at calling user air interface	M
Call priority	M
Call time-out	M
Simplex/duplex selection	M
Transmission request permission	O (see note 2)
Transmission grant	O (see note 2)
NOTE 1: May be sent if the service requested (in the service element basic service information) is a speech service.	
NOTE 2: Mandatory if this information flow is sent by FE1 (corresponding to controlling SwMI). Not to be included if this information flow is sent by FE8.	

### 5.2.2.3 CHARACTERISTIC CHANGE

CHARACTERISTIC CHANGE is an unconfirmed information flow across relationship rh from FE8 to FE7, rg from FE7 to FE2 and ra from FE2 to FE1. It is an advance indication to the originating one that the terminating SwMI wants to change some of the characteristics requested in the SETUP information flow (e.g. basic service not supported, or simply call set-up time-out extension). The sending of this information flow by FE8 is optional.

Table 5 lists the service elements within the CHARACTERISTIC CHANGE information flow.

**Table 5: Contents of CHARACTERISTIC CHANGE**

Service element	Request
Call time-out in set-up phase	O
Simplex/duplex selection	O
Call status	O
Basic service information	O (see note)
NOTE: Only if different from requested.	

### 5.2.2.4 COMPLETE

COMPLETE is an information flow:

- across relationship ra, between FE1 and FE2;
- across relationship rh, between FE7 and FE8; and:
  - if the called user is registered in SwMI B, depending on whether or not FE4 is collocated with FE1, across relationship rf, between FE6 and FE7, or across relationship rc, between FE2 and FE4;
  - if the called user is registered in SwMI C (after having migrated):
    - if the call is forward switched, across relationships rc, between FE2 and FE4, re, between FE4 and FE6, and rf, between FE6 and FE7;
    - if the call is re-routed, across relationship rf, between FE6 and FE7.

If the call is established using on/off hook signalling, COMPLETE is a confirmed information flow, as shown in figure 9. It is an unconfirmed information flow if the call is established using direct set-up signalling, as shown in figure 10.

Table 6 lists the service elements within the COMPLETE information flow when it is a confirmed flow, and table 7 lists them when it is an unconfirmed flow.

**Table 6: Contents of confirmed COMPLETE information flow**

Service element	Request	Response
Terminating SwMI MNI	M	-
Call amalgamation	O	-
Call time-out	M	M
Connected party identity	M	-
Simplex/duplex selection	M	-
Transmission request permission	-	M
Transmission grant	-	M

**Table 7: Contents of unconfirmed COMPLETE information flow**

Service element	Request
Call time-out	M
Transmission request permission	M
Transmission grant	M

### 5.2.2.5 INFORM 1

INFORM 1 is a confirmed information flow across rb from FE2 to FE3, and across rd from FE4 to FE5. It is used by FE2 to get information on how to route the invoked ANF-ISIIC to SwMI B, or in case of re-routing, to SwMI C, and by FE4, to get information on how to route the invoked ANF-ISIIC to SwMI C in case of forward switching.

Table 8 lists the service elements within the INFORM 1 information flow.

**Table 8: Contents of INFORM 1**

Service element	Request	Response
Routing information towards FE4 or FE7	-	M
Call priority	M	(see note)
NOTE: The routing information provided (by FE3 or FE5) in response to the request shall take into account the call priority if SS-PC or SS-PPC have been invoked.		

### 5.2.2.6 INFORM 2

INFORM 2 is a confirmed information flow across rd from FE4 to FE5. It is used by FE4 to know the SwMI where the called user is registered (i.e. in SwMI B, or in SwMI C), and to get information on the SS-BIC, SS-CAD or SS-CF possibly activated.

There are no elements in the INFORM 2 request/indication information flow. Table 9 lists the service elements within the INFORM 2 response/confirmation information flow.

**Table 9: Contents of INFORM 2 response/confirmation information flow**

Service element	Response
Identity of the SwMI where the called user is registered	M
SS-BIC activation	M
SS-BIC "definition"	C (see note)
SS-CAD activation	M
SS-CAD "definition"	C (see note)
SS-CF activation	M
SS-CF "definition"	C (see note)
NOTE: Mandatory if the corresponding supplementary service has been activated.	

### 5.2.2.7 INFORM 3

INFORM 3 is a confirmed information flow across rb from FE2 to FE3. It is used by FE2 in the case where SwMI C coincides with SwMI A, to get information on the local SS-BIC, SS-CAD or SS-CF possibly activated.

There are no elements in the INFORM 3 request/indication information flow. Table 10 lists the service elements within the INFORM 3 response/confirmation information flow.

**Table 10: Contents of INFORM 3 response/confirmation information flow**

Service element	Response
Local SS-BIC activation	M
Local SS-BIC "definition"	C (see note)
Local SS-CAD activation	M
Local SS-CAD "definition"	C (see note)
Local SS-CF activation	M
Local SS-CF "definition"	C (see note)
NOTE: Mandatory if the corresponding (local) supplementary service has been activated.	

### 5.2.2.8 MIGRATION

MIGRATION is an information flow across relationship rc from FE4 to FE2. The MIGRATION request information flow is sent by FE4 when the called user is registered in SwMI C (i.e. the home SwMI of the called user is SwMI B and this user has migrated). It is a confirmed information flow unless FE2 has informed in advance FE4 that the call has to be forward switched when the called user has migrated (in another SwMI than the originating one). The MIGRATION information flow shall not be sent when SwMI C coincides with SwMI A.

NOTE: It is then replaced by the TROMBONE information flow - see hereafter.

Table 11 lists the service elements within the MIGRATION information flow when it is a confirmed flow, and table 12 lists them when it is an unconfirmed flow.

**Table 11: Contents of confirmed MIGRATION information flow**

Service element	Request	Confirm
Identity of the SwMI where the called user is registered	M	-
Forward switching (see note)	M	M
NOTE: In the request information flow, this information element indicates whether forward switching is supported or not (or possibly if FE4 refuses that forward switching takes place). In the response information flow, it indicates whether FE2 wants that the call be forward switched or not, i.e. the call is going to re-routed. In the latter case, this information flow shall be sent to FE4 with the PISN RELEASE request/indication information flow.		

**Table 12: Content of unconfirmed MIGRATION information flow**

Service element	Request
Identity of the SwMI where the called user is registered	M

### 5.2.2.9 MODIFY

MODIFY is a confirmed information flow across relationships ra, rg and rh, from FE1 to FE8 via FE2 and FE7 and vice-versa. The MODIFY request/indication information flow sends a request to modify the existing basic service into another one, and/or to change from duplex to half-duplex, or vice-versa, and/or to change the call duration. The MODIFY response/confirmation information flow indicates the response to this request. FE2 or FE7 may reject such request if the ISI gateways in which they are located do not support the user information 8 kbit/s encoding entailed by a request to change the basic service.

Table 13 lists the service elements within the MODIFY information flow.

**Table 13: Contents of MODIFY**

Service element	Request	Confirm
Basic service information:		
Circuit mode service	O	O
Communication type	O	O
Data call capacity	C (see note)	C (see note)
Data service	C (see note)	C (see note)
Encryption flag	O	O
Speech service	C (see note)	C (see note)
Call time-out	O	O
Simplex/duplex selection	O	O
NOTE: Depending on the value of circuit mode service.		

### 5.2.2.10 RELEASE

RELEASE is an unconfirmed information flow across relationships ra, rh, rc, rf and rg. It shall be sent to clear the call (together with the invoked ANF-ISIIC).

NOTE: As recalled in the note to figure 15, the PISN RELEASE information flow is a confirmed information flow on all PISN basic call relationships which support relationships rc, rf and rg. But this does not make the ANF-ISIIC RELEASE information flow a confirmed one.

Table 14 indicates the only service element within the RELEASE information flow.

**Table 14: Contents of RELEASE**

Service element	Request
Disconnect cause	M

### 5.2.2.11 SETUP

SETUP is a confirmed information flow:

- across relationship ra from FE1 to FE2;
- across relationship rh from FE7 to FE8; and
  - if the called user is registered in SwMI B, depending on whether or not FE4 is collocated with FE1, across relationship rf from FE6 to FE7, or across relationship rc from FE2 to FE4;
  - if the called user is registered in SwMI C (after having migrated):
    - if the call is forward switched, across relationships rc from FE2 to FE4, re from FE4 to FE6, and rf from FE6 to FE7;
    - if the call is re-routed, across relationship rf from FE6 to FE7.

The SETUP request/indication information flow enables the TETRA call to be set-up by the originating SwMI up to the terminating SwMI. The SETUP response/confirmation information flow is sent by the terminating SwMI upon the first response of the called user, i.e.:

- in the case of on/off hook signalling, this first response will generate a U-ALERT air interface PDU. The (ISI-IC-)SETUP response/confirmation information flow shall then be carried together with the PISN REPORT request/indication information flow(s). The TNCC ALERT primitive may be sent to the calling user by SwMI A call control application;
- while in the case of direct set-up signalling, this first response will generate a U-CONNECT air interface PDU. The ISI-IC-SETUP response/confirmation information flow shall then be carried together with the PISN SETUP response/confirmation information flow.

Table 15 lists the service elements within the SETUP information flows.

**Table 15: Contents of SETUP**

Service element	Request	Confirm
Originating SwMI MNI	M	-
Routeing method choice	O	-
Terminating SwMI MNI	-	O (see note 2)
Call time-out, set-up phase	M	O (see note 3)
Basic service information:	-	-
Circuit mode service	M	O (see note 2)
Communication type	M	O (see note 2)
Data call capacity	C (see note 1)	C (see note 1)
Data service	C (see note 1)	C (see note 1)
Encryption flag	M	O (see note 2)
Speech service	C (see note 1)	C (see note 1)
Speech services supported	O (see note 4)	-
Security level at calling user air interface	M	M
Call priority	M	O (see note 2)
Call amalgamation	-	O (see note 2)
Call time-out	M	O (see note 2)
Called/Connected party number	M	O (see note 2)
Calling party number	M	-
Hook method selection	M	M (see note 5)
Request to transmit/send data	M	-
Simplex/duplex selection	M	M
Transmission request permission	M	-
Transmission grant	M	-
Call queued	-	O (see note 6)
NOTE 1: Depending on the value of circuit mode service.		
NOTE 2: Mandatory in the case of direct set-up signalling. Not to be included in the case of on/off hook signalling.		
NOTE 3: Mandatory in the case of on/off hook signalling. Not to be included in the case of direct set-up signalling.		
NOTE 4: May be sent if the service requested is a speech service.		
NOTE 5: Mandatory to indicate the actual choice made by the called user: in other words, it indicates whether the called user has accepted or changed the hook selection method requested.		
NOTE 6: Optional in the case of on/off hook signalling. Not to be included in the case of direct set-up signalling.		

NOTE: The service element call priority has been included in table 15 for the purpose of alignment with the definition of the TNCC-SETUP primitive in table 48 of EN 300 392-2 [1]. From a formal point of view it should not have been included in that table because it is not needed by ANF-ISIIC basic call: it is needed only for the interaction between the invoked ANF-ISIIC and the supplementary services SS-PC and SS-PPC.

#### 5.2.2.12 SETUP PROLONGATION

SETUP PROLONGATION is an unconfirmed information flow across relationships ra, rg and rh, from FE1 to FE8 via FE2 and FE7 and vice-versa, to request a set-up time-out extension. Table 16 shows the service element within the SETUP PROLONGATION information flow.

**Table 16: Content of SETUP PROLONGATION**

Service element	Request
Call time-out, set-up phase	M

### 5.2.2.13 TROMBONE

TROMBONE shall be a confirmed information flow across relationship rc from FE4 to FE2. The TROMBONE request information flow is sent by FE4 when FE4 has identified that SwMI C coincides with SwMI A. The TROMBONE response is then a confirmation that the invoked ANF-ISIIC FE4 may be cleared.

Table 17 lists the service elements within the TROMBONE request/indication information flow (sent by FE4). There are no service elements within the TROMBONE response/confirmation information flow (sent by FE2).

**Table 17: Contents of TROMBONE request/indication information flow**

Service element	Request
Terminating and originating SwMIs coinciding	M
Results of possible SS-BIC and SS-CAD (for incoming calls)	M (see notes 1 and 2)
SS-CF invoked	M
SS-CF "definition"	C (see note 3)
NOTE 1: If none of these supplementary services has been activated, this shall be indicated.	
NOTE 2: The case where the result would be that the call is not authorized by SS-CAD is excluded, since it would not result in the sending of a TROMBONE request information flow, but in the ANF-ISIIC call establishment being rejected.	
NOTE 3: Mandatory if SS-CF has been invoked.	

NOTE: According to EN 300 392-12-4 [8] of the call forwarding supplementary services, the only call forwarding supplementary services which may be invoked in the home SwMI of the SS-CF served user when that user has migrated (in the specific case where TROMBONE is sent, that user has migrated into SwMI A) are SS-CFU or SS-CFNrc.

### 5.2.2.14 TX-CEASED

#### 5.2.2.14.1 TX-CEASED 1

TX-CEASED 1 is an unconfirmed information flow across ri from FE8 to FE1 to indicate that transmission from the called user has ceased.

Table 18 lists the service elements within the TX-CEASED 1 information flow.

**Table 18: Contents of TX-CEASED 1**

Service element	Request
Notification indicator	O
Proprietary	O

#### 5.2.2.14.2 TX-CEASED 2

TX-CEASED 2 is an unconfirmed information flow across ri from FE1 to FE8 to indicate that transmission from the calling user has ceased. It is also used as a response to a TX-CEASED 1 when transmit permission has not been allocated to the calling party and the called party has ceased talking.

Table 19 lists the service elements within the TX-CEASED 2 information flow.

**Table 19: Contents of TX-CEASED 2**

Service element	Request
Transmission request permission	M
Notification indicator	O
Proprietary	O



### 5.2.2.15 TX-CONTINUE 1

TX-CONTINUE 1 is an unconfirmed information flow across ri from FE1 to FE8 to indicate that transmission has resumed.

Table 20 lists the service elements within the TX-CONTINUE 1 information flow.

**Table 20: Contents of TX-CONTINUE 1**

Service element	Request
Continue	M
Transmission request permission	M
Notification indicator	O
Proprietary	O

### 5.2.2.16 TX-CONTINUE 2

TX-CONTINUE 2 is an unconfirmed information flow across ri from FE8 to FE1 to indicate that transmission may resume.

Table 21 lists the service elements within the TX-CONTINUE 2 information flow.

**Table 21: Contents of TX-CONTINUE 2**

Service element	Request
Notification indicator	O
Proprietary	O

### 5.2.2.17 TX-DEMAND

TX-DEMAND is an unconfirmed information flow across ri from FE8 to FE1. It is a request from the terminating SwMI to the originating/controlling SwMI for transmission grant (following the corresponding request received from the called user).

Table 22 lists the service elements within the TX-DEMAND information flow.

**Table 22: Contents of TX-DEMAND**

Service element	Request
Transmission request permission	M
Encryption control	M
Notification indicator	O
Proprietary	O

### 5.2.2.18 TX-GRANTED

TX-GRANTED is an unconfirmed information flow across ri from FE1 to FE8. It is an indication to the terminating SwMI from the originating/controlling SwMI that permission to transmit has been granted to either the calling or the called user.

Table 23 lists the service elements within the TX-GRANTED information flow.

**Table 23: Contents of TX-GRANTED**

Service element	Request
Transmission grant	M
Transmission request permission	M
Encryption control	M
Notification indicator	O
Proprietary	O

### 5.2.2.19 TX-INTERRUPT

TX-INTERRUPT is an unconfirmed information flow across ri from FE1 to FE8. It is an indication to the terminating SwMI from the originating/controlling SwMI that permission to transmit has been withdrawn.

Table 24 lists the service elements within the TX-INTERRUPT information flow.

**Table 24: Contents of TX-INTERRUPT**

Service element	Request
Transmission grant	M
Transmission request permission	M
Encryption control	M
Notification indicator	O
Proprietary	O

### 5.2.2.20 TX-WAIT

TX-WAIT is an unconfirmed information flow across ri from FE1 to FE8 or from FE8 to FE1 to indicate that transmission has been interrupted.

Table 25 lists the service elements within the TX-WAIT information flow.

**Table 25: Contents of TX-WAIT**

Service element	Request
Transmission request permission	M (see note)
Notification indicator	O
Proprietary	O
NOTE: When sent by FE8 this service element has no control function and the contents of it shall be ignored.	

## 5.2.3 Relationship of information flows to basic call information flows

The (TETRA ANF-ISIIC) SETUP request/indication information flows across relationships rc and rf shall be sent in conjunction with the PISN basic call r2\_setup request/indication information flows sent to initiate the establishment of the necessary PISN call.

The (TETRA ANF-ISIIC) SETUP response/confirmation information flows across relationships rf and rc shall be sent in conjunction with either the PISN basic call r2\_report request/indication information flows if the called user uses on/off hook signalling, or the PISN basic call r2\_setup response/confirmation information flows if the called user uses direct set-up signalling.

The (TETRA ANF-ISIIC) COMPLETE request/indication information flow across relationships rc and rf shall be sent in conjunction with the PISN basic call r2\_setup response/confirmation if the called user uses on/off hook signalling.

The (TETRA ANF-ISIIC) RELEASE request/indication information flows across relationships rc, rf and rg shall be sent in conjunction with the PISN basic call r2\_release request/indication information flows.

None of the other (ANF-ISIIC) information flows are related to any PISN basic call information flows.

## 5.3 Functional entity actions

The FE actions in the figures 9 to 22 in clauses 5.2.1.1 to 5.2.1.10 shall fulfil the requirements set to the functional entities.

## 5.4 Allocation of functional entities to physical equipment/SwMIs

The different scenarios for the allocation of FEs to physical equipment/SwMIs are shown in table 26.

Scenario 1 corresponds to the case where the called user is registered in its home SwMI, this SwMI being different from the originating SwMI.

Scenarios 2 and 3 both correspond to the case where the called user has migrated to a third SwMI (SwMI C), its home SwMI being different from the originating SwMI. In scenario 2, the call is forward switched (in SwMI B); while in scenario 3, it is re-routed (in SwMI A).

Scenario 4 is a special case of scenario 3 when SwMI C coincides with SwMI A: the invoked ANF-ISIIC shall then be cleared and as stated in clause 4.2.3.2, SwMI A call control application shall establish the call as an intra-TETRA call.

Scenario 5 corresponds to the case where the called user has migrated, its home SwMI being the originating SwMI.

NOTE: In scenario 5, there are only two SwMIs. In line with clause 3.1, on definitions, the second SwMI has been called SwMI B.

Table 26: Scenarios for the allocation of FEs to physical equipment/SwMIs

	FE1/Originating SwMI CCAp	FE2/Originating SwMI ISI gateway	FE3/Client of originating SwMI databases	FE4/hSwMI migration handling	FE5/Client of hSwMI databases	FE6/migration routeing	FE7/Terminating SwMI ISI gateway	FE7/Terminating SwMI CCAp
Scenario 1	Any SwMI CCAp (SwMI A CCAp)	SwMI A ISI outgoing gateway	SwMI A routeing table client	SwMI B	SwMI B	-	SwMI B ISI incoming gateway	SwMI B CCAp
Scenario 2	Any SwMI CCAp (SwMI A CCAp)	SwMI A ISI outgoing gateway	SwMI A routeing table client	SwMI B	SwMI B	SwMI B ISI forward switching entity	SwMI C ISI incoming gateway	SwMI C CCAp
Scenario 3	Any SwMI CCAp (SwMI A CCAp)	SwMI A ISI outgoing gateway	SwMI A routeing table client	SwMI B	SwMI B	SwMI A ISI re-routeing entity	SwMI C ISI incoming gateway	SwMI C CCAp
Scenario 4	Any SwMI CCAp (SwMI A CCAp)	SwMI A ISI outgoing gateway	SwMI A routeing table client	SwMI B	SwMI B	SwMI A CCAp		
Scenario 5	Any SwMI CCAp (SwMI A CCAp)	SwMI A ISI outgoing gateway	SwMI A routeing table client	- (see note)	- (see note)	SwMI A ISI outgoing gateway	SwMI B ISI incoming gateway	SwMI B CCAp
NOTE: In scenario 5, FE4 and FE 5 are not ANF-ISIIC FEs: the corresponding functions are ensured by SwMI A call control application.								

## 6 ANF-ISIIC stage 3 specification

### 6.1 ANF-ISIIC description

See clause 4.

### 6.2 ANF-ISIIC operational requirements

The requirements specific for each type of SwMI are stated below. In addition, each SwMI shall comply with the requirements stated in:

- annex ZA of ISO/IEC 11572 [9], for the support of the PSS1 message segmentation/re-assembly procedures; and
- clause 8.4 of EN 300 392-3-1 [2], for the support of the ROSE protocol.

#### 6.2.1 Requirements on the originating SwMI

The originating SwMI entity which operates an invoked ANF-ISIIC shall support call establishment and call clearing procedures for an originating PINX, as specified in ISO/IEC 11572 [9]. In addition, the following rules shall apply for the contents of some information elements in the SETUP message:

- the sending complete information element shall be included when the called party number is complete;

NOTE 1: Although it might be expected that the called party number is sent en-bloc, the use of (PISN) overlap sending (see clauses 10.1.1, 10.1.3 and 10.1.4 of ISO/IEC 11572 [9] for the corresponding descriptions) is not prevented by the present document.

- the bearer capability information element shall be encoded with information transfer capability code equal to unrestricted digital information, and an information transfer rate code equal to 64 kbit/s;

NOTE 2: As an option, when this may have been standardized (either in ISO/IEC 11572 [9], or in the corresponding ETSI standard), the information transfer rate code might be equal to either 8 kbit/s or multi-rate (8 kbit/s base rate). For the latter, the multiplier code would be chosen from 2 to 4. This would correspond to the use of an  $N \times 8$  kbit/s bearer service.

- no progress indicator information element shall be included;
- the calling party number information element shall be included. The corresponding number shall be some PISN number identifying the calling SwMI, or one of its entities. Thus its numbering plan identification code shall be equal to either private numbering plan or unknown. No presentation or screening indicators shall be included (i.e. the calling party information element shall not include octet 3a);

NOTE 3: The type of number code associated to the former will be as defined in table 26 of ISO/IEC 11572 [9].

NOTE 4: Putting an identifier of the calling SwMI in the calling party number information element is not in line with the requirement in clause 10.5.1 of ISO/IEC 11572 [9] that the number included in this information element shall be that of the calling (TETRA) user.

The reasons for this are first that the calling party number information element is not needed for PISN signalling, and second that any TETRA control entity in a SwMI on the call path (i.e. the terminating SwMI or when different from this SwMI, the called SwMI) needing to know the calling party number will get it as part of the complementary TETRA set-up information (see table 27).

- no calling party sub-address information element shall be included;
- the number included in the called party number information element shall be some PISN number identifying the called SwMI, or one of its entities. Thus its numbering plan identification code shall be equal to either private numbering plan or unknown;

NOTE 5: The type of number code associated to the former will be as defined in table 26 of ISO/IEC 11572 [9].

- no called party sub-address information element shall be included;
- no lower layer or high layer compatibility information elements shall be included; and
- the transit counter information element, defined in EN 300 172 [7].

Generic procedures for the call related control of supplementary services, specified in ISO/IEC 11582 [11] for an End PINX, shall apply for sending or receiving TETRA specific messages or TETRA information complementary to PSS1 basic call messages. Such messages or complementary information shall be encoded as ROSE operation Invoke APDUs in facility information elements. Notably complementary TETRA set-up information shall be sent in a facility information element in the SETUP message.

NOTE 6: No support of any generic procedure for the call independent control (connection oriented) of supplementary services is required since the ANF-ISIIC protocol is only call related.

## 6.2.2 Requirements on the terminating SwMI

The terminating SwMI entity which operates an invoked ANF-ISIIC shall support call establishment and call clearing procedures for a terminating PINX, as specified in ISO/IEC 11572 [9]. In addition, the following rules shall apply for the contents of the connected number and connected sub-address information elements in the CONNECT message:

- the connected number information element shall be included. The corresponding number shall be some PISN number identifying the terminating SwMI, or one of its entities. Thus its numbering plan identification code shall be equal to either private numbering plan or unknown. No presentation or screening indicators shall be included (i.e. the called party information element shall not include octet 3a);

NOTE 1: The type of number code associated to the former will be as defined in table 26 of ISO/IEC 11572 [9].

NOTE 2: Putting an identifier of the terminating SwMI in the connected number information element is not in line with the requirement in clause 10.6.4 of ISO/IEC 11572 [9] that the number included in this information element is that of the connected (TETRA) user.

The reasons for this are first that the connected number is not needed for PSS1 signalling and second that any TETRA control entity in a SwMI on the call path (i.e. the originating SwMI or when different from the terminating SwMI, the called SwMI) needing to know the connected party number will get it as part of the complementary TETRA set-up response information (see table 32).

- no connected party sub-address information element shall be included.

No progress indicator should be sent in the ALERTING or CONNECT messages, since no tones or announcements will be sent, and it shall not be considered that an interworking situation occurs for inter-TETRA individual calls. And for the same reason, no PROGRESS message should be sent.

Generic procedures for the call related control of supplementary services, specified in ISO/IEC 11582 [11] for an End PINX, shall apply for receiving or sending TETRA specific messages or TETRA information complementary to PSS1 basic call messages. Such messages or complementary information shall be encoded as ROSE operation Invoke APDUs in facility information elements, notably in the ALERTING or CONNECT messages.

## 6.2.3 Requirements on a called SwMI when it is different from the terminating SwMI

When the called user is not registered in the called SwMI, this SwMI shall redirect the call. Its redirecting entity which operates an invoked ANF-ISIIC shall support call establishment and call clearing procedures for the incoming side of an inter-PINX link, as specified in ISO/IEC 11572 [9].

Generic procedures for the call related control of supplementary services, specified in ISO/IEC 11582 [11] for an End PINX, shall apply.

## 6.2.4 Requirements on a routing SwMI

The routing SwMI entity which operates an invoked ANF-ISIIC shall support call establishment and call clearing procedures for the outgoing side of an inter-PINX link, as specified in ISO/IEC 11572 [9]. The number included in the calling party number information element of its PSS1 SETUP message shall be the same PISN number as in the PSS1 SETUP message sent by the originating SwMI (see clause 6.2.1). No presentation or screening indicators shall be included (i.e. the calling party information element shall not include octet 3a). The number included in the called party number information element shall be some PISN number identifying the terminating SwMI, or one of its entities. Thus its numbering plan identification code shall be equal to either private numbering plan or unknown.

NOTE 1: The type of number code associated to the former will be as defined in table 26 of ISO/IEC 11572 [9].

In addition, after having sent this SETUP message, except if the routing SwMI is also the originating SwMI (case of re-routing), the routing SwMI shall support the call establishment and call clearing procedures for a transit PINX.

NOTE 2: In the case of forward switching, the incoming side procedures of a transit for receiving the SETUP message are ensured by the called SwMI. They are not needed in the case of re-routing.

Generic procedures for the call related control of supplementary services, specified in ISO/IEC 11582 [11] for an End PINX, shall apply.

## 6.2.5 Requirements on a SwMI with PSTN/ISDN/PISN incoming gateway

The SwMI entity which operates an invoked ANF-ISIIC for extending an external individual call to a TETRA called user over the ISI shall support call establishment and call clearing procedures for an incoming gateway PINX, as specified in ISO/IEC 11572 [9]. In addition, the following rules shall apply for the contents of some information elements in the SETUP message:

- the sending complete information element shall be included when the called party number is complete;

NOTE 1: Although, it might be expected that the called party number is sent en-bloc, the use of (QSIG) overlap sending (see clauses 10.1.1, 10.1.3 and 10.1.4 of ISO/IEC 11572 [9] for the corresponding descriptions) is not prevented by the present document.

- the bearer capability information element shall be encoded with information transfer capability code equal to unrestricted digital information, and an information transfer rate code equal to 64 kbit/s;

NOTE 2: As an option, when this may have been standardized (either in ISO/IEC 11572 [9], or in the corresponding ETSI standard), the information transfer rate code might be equal to either 8 kbit/s or multi-rate (8 kbit/s base rate). For the latter, the multiplier code would be chosen from 2 to 4. This would correspond to the use of an  $N \times 8$  kbit/s bearer service.

- one, two or three progress indicator information elements shall be included, depending on the number of progress description numbers to send, with:
  - a location code equal to transit network; and
  - for a PSTN call:
    - a CCITT progress description number 1 "call is not end-to-end ISDN";
    - an ISO/IEC progress description number 16 "interworking with a public network"; and
    - if the PSTN access line interface used at the gateway cannot deliver a release signal (e.g. standard PSTN extension line - with no battery reversal signal), an ISO/IEC progress description number 17 "interworking with a network unable to supply a release signal" (or an ISO/IEC progress description number 18 or 19, depending on whether it can supply a release signal after answer, but not before, or before answer, but not after);
  - for a public ISDN call: an ISO/IEC progress description number 16 "interworking with a public ISDN"; or
  - for a PISN call: an ECMA progress description number 20 "interworking with a another private network";

- the calling party number information element shall be included. The corresponding number shall be some PISN number identifying the gateway SwMI, or one of its entities. Thus its numbering plan identification code shall be equal to either private numbering plan or unknown. No presentation or screening indicators shall be included (i.e. the calling party information element shall not include octet 3a);

NOTE 3: The type of number code associated to the former will be as defined in table 26 of ISO/IEC 11572 [9].

NOTE 4: Putting an identifier of the calling SwMI in the calling party number information element is not in line with the requirement in clause 10.7.1 of ISO/IEC 11572 [9] that the number included in this information element shall be the calling party number received from PSTN, public ISDN or PISN, if any.

The reasons for this are the same as those given in note 4 of clause 6.2.1.

- no calling party sub-address information element shall be included;
- the number included in the called party number information element shall be some PISN number identifying the called SwMI, or one of its entities. Thus its numbering plan identification code shall be equal to either private numbering plan or unknown;

NOTE 5: The type of number code associated to the former will be as defined in table 26 of ISO/IEC 11572 [9].

- no called party sub-address information element shall be included;
- no lower layer or high layer compatibility information elements shall be included; and
- the transit counter information element, defined in EN 300 172 [7].

Generic procedures for the call related control of supplementary services, specified in ISO/IEC 11582 [11] for an End PINX, shall apply for sending or receiving TETRA specific messages or TETRA information complementary to PSS1 basic call messages. Such messages or complementary information shall be encoded as ROSE operation Invoke APDUs in facility information elements. Notably complementary TETRA set-up information shall be sent in a facility information element in the SETUP message.

## 6.2.6 Requirements on a SwMI with PSTN/ISDN/PISN outgoing gateways

The SwMI entity which operates an invoked ANF-ISIIC for routeing an external individual call from a TETRA called user over the ISI shall support call establishment and call clearing procedures for an outgoing gateway PINX, as specified in ISO/IEC 11572 [9]. In addition, the following rules shall apply for the contents of the called party sub-address information element in the SETUP message and for that of the connected number and connected sub-address information elements in the CONNECT message:

- the connected number information element shall be included in the CONNECT message. The corresponding number shall be some PISN number identifying the gateway SwMI, or one of its entities. Thus its numbering plan identification code shall be equal to either private numbering plan or unknown. No presentation or screening indicators shall be included (i.e. the called party information element shall not include octet 3a);

NOTE 1: The type of number code associated to the former will be as defined in table 26 of ISO/IEC 11572 [9].

NOTE 2: Putting an identifier of the gateway SwMI in the connected number information element is not in line with the requirement in clause 10.8.5 of ISO/IEC 11572 [9] that the connected number included in this information element shall be that received from PSTN, public ISDN or PISN, if any.

The reasons for this are the same as those given in note 2 of clause 6.2.2.

- no connected party sub-address information element shall be included in the CONNECT message.



In addition, one, two or three progress indicator information elements shall be sent to the calling SwMI by the gateway SwMI in the appropriate PSS1 message, to indicate interworking, depending on the number of progress description numbers, with:

- a location code equal to transit network; and
- for a PSTN call:
  - a CCITT progress description number 1 "call is not end-to-end ISDN";
  - an ISO/IEC progress description number 16 "interworking with a public network"; and
  - if the PSTN access line interface used at the gateway cannot deliver a release signal (e.g. standard PSTN extension line-with no battery reversal signal), an ISO/IEC progress description number 17 "interworking with a network unable to supply a release signal" (or an ISO/IEC progress description number 18 or 19, depending on whether it can supply a release signal after answer, but not before, or before answer, but not after);
- for a public ISDN call: an ISO/IEC progress description number 16 "interworking with a public ISDN"; or
- for a PISN call: an ECMA progress description number 20 "interworking with another private network".

Generic procedures for the call related control of supplementary services, specified in ISO/IEC 11582 [11] for an End PINX, shall apply for receiving or sending TETRA specific messages or TETRA information complementary to PSS1 basic call messages. Such messages or complementary information shall be encoded as ROSE operation Invoke APDUs in facility information elements, notably in the PSS1 ALERTING and CONNECT messages.

## 6.3 ANF-ISIIC coding requirements

As already mentioned in clause 6.2, TETRA specific messages or TETRA information complementary to PSS1 basic call messages shall be sent using an Invoke APDU of the ROSE operation `tetraIsiMessage` defined in table 10 of EN 300 392-3-1 [2]. This table has been reproduced in the informative annex B.

More precisely:

- the TETRA specific messages or TETRA information complementary to PSS1 basic call messages shall be the TETRA PDUs defined in clause 6.3.1; and
- those PDUs shall be included in the `tetraMessage` data element of the ROSE operation `tetraIsiMessage`.

The resulting ROSE APDU shall be sent in a facility information element in the relevant PSS1 message (see ISO/IEC 11582 [11] clause 10).

NOTE: Clearly, those PSS1 messages will be call related.

### 6.3.1 TETRA PDUs

The TETRA PDUs referred to in the ASN.1 definition in table 25 shall be encoded using the same rule as defined in annex E of EN 300 392-2 [1] (for TETRA air interface PDUs).

NOTE 1: As a general rule, the definition of those PDUs has been done on the basis of the corresponding air interface downstream messages. In other words, the sending SwMI is preparing the corresponding message to be sent by the other SwMI on its air interface.

Thus generally those PDUs include the same information elements as air interface messages. However, no facility information elements are included in those PDUs since ANF-ISISS is used instead (see clauses 9 and 10 of EN 300 392-9 [6]).

NOTE 2: Even when only one TETRA PDU type has been defined below for inclusion in a given PSS1 message (e.g. in the ALERTING message), the information element PDU type has been included in this TETRA PDU. The main reason for this is to allow the possibility of defining in the future other TETRA PDU types in the same PSS1 message. Additionally it might ease the processing of these PDUs by the destination SwMI call control application.

The definitions of all possible TETRA PDUs, in the various PSS1 messages, are given below.

### 6.3.1.1 TETRA PDU giving complementary information in the PSS1 SETUP message sent by the originating or the incoming gateway SwMI

The contents and the encoding of the TETRA PDU giving complementary information in the PSS1 SETUP message sent by the originating or incoming gateway SwMI shall be as defined in table 27.

**Table 27: Contents of TETRA PDU in the PSS1 SETUP message**

Information element	Length	Type	Owner	C/O/M	Remark
PDU type	6	1	CCAp	M	ISI-SETUP
Selected area number	8	1	ANF	M	
Originating SwMI MNI	24	1	ANF	M	
Call has been forward switched	1	1	ANF	M	
Last Forwarding SwMI MNI	24		ANF	C	(see note 1)
Routeing method choice	3	1	ANF	M	
SS-CF invocation counter	5	1	SS	M	
Call time-out, set-up phase	3	1	CCAp	M	
Call time-out	4	1	CCAp	M	
Hook method selection	1	1	CCAp	M	
Simplex/duplex selection	1	1	CCAp	M	
Basic service information	8	1	CCAp	M	
Speech service requested	3		CCAp	C	(see note 2)
Security level at calling user air interface	2	1	MM	M	(see note 3)
Call priority	4	1	CCAp	M	
Called/forwarded-to party SSI	24	1	CCAp	M	(see note 4)
Called/forwarded-to party extension	24	1	CCAp	M	(see notes 4 and 5)
Number of digits in called/forwarded-to external subscriber number	5	1	CCAp	M	(see note 6)
Called/forwarded-to external subscriber number	variable		CCAp	C	(see note 7)
Calling party presentation indicator	2	1	SS	M	
Calling party SSI	24	1	CCAp	M	(see note 8)
Calling party extension	24	1	CCAp	M	(see note 8)
Number of digits in calling external subscriber number	5	1	CCAp	M	(see note 9)
Calling external subscriber number	variable		CCAp	C	(see note 10)
MSISDN present as external subscriber number	1		CCAp	C	(see note 11)
Calling external subscriber number parameters	9		CCAp	C	(see note 11)
Call identified as fleet call	1	1	CCAp	M	
Calling party fleet number SSI	24		CCAp	C	(see note 12)
Called/forwarded-to party fleet number SSI	24		CCAp	C	(see note 12)
Override SS-CAD invocation	1	1	SS	M	(see note 13)
Speech services supported	8	2	CCAp	O	(see note 14)

Information element	Length	Type	Owner	C/O/M	Remark
Notification indicator	6	2	SS	O	
Proprietary		3	-	O	
<p>NOTE 1: Conditional on the value of the information element call has been forward switched indicating that the call has been routed by forward switching (at some stage); since if the call has been re-routed all the way, the last forwarding SwMI is the originating SwMI.</p> <p>NOTE 2: Conditional on the binary value of the information sub-element circuit mode type in the information element basic service information being equal to 0 (i.e. the call requested is a speech call).</p> <p>NOTE 3: In the case of incoming calls from PSTN/ISDN/PISN, the name of this information element should be understood as "security level used in the other network". Indicates if air interface encryption is being used at the calling air interface.</p> <p>NOTE 4: In the case of an external outgoing call, the called/forwarded-to party SSI and the called/forwarded-to party extension shall be those of the outgoing gateway SwMI.</p> <p>NOTE 5: Is the same as last forwarding SwMI MNI in the case of migration of the called/forwarded-to party when the invoked ANF-ISIIC has been forward switched through the home SwMI of that party.</p> <p>NOTE 6: Shall be equal to 0 when no called/forwarded-to external subscriber number is present, or to N, N being the number of digits which the called/forwarded-to external subscriber number comprises.</p> <p>NOTE 7: The length in bits of this information element shall be equal to <math>4 \times N</math>, N being the number of digits in the called/forwarded-to external subscriber number (see note 6), i.e. this information element shall be conditional on the value of N.</p> <p>NOTE 8: In the case of an external incoming call, the calling party SSI and the calling party extension shall be those of the incoming gateway SwMI.</p> <p>NOTE 9: Shall be equal to 0 when no calling external subscriber number is present, or to N, N being the number of digits which the calling external subscriber number comprises.</p> <p>NOTE 10: The length in bits of this information element shall be equal to <math>4 \times N</math>, N being the number of digits in the calling external subscriber number (see note 9), i.e. this information element shall be conditional on the value of N.</p> <p>NOTE 11: Conditional on the value of the information element number of digits in calling external subscriber number being different from 0.</p> <p>NOTE 12: Conditional on the value of the information element call identified as fleet call indicating that the call has been identified as being a fleet call.</p> <p>NOTE 13: See interaction between SS-CCBS and SS-CAD.</p> <p>NOTE 14: May be present only when the information element speech service requested is present (see note 2).</p>					

NOTE 1: Compared to the definition of the D-SETUP air interface downlink PDU in clause 14.7.2 of EN 300 392-2 [1], the following information elements have been deleted:

- calling type identifier, since it is always TETRA subscriber identity (actually ITSI);
- temporary address, because that information element is used only for group calls (and in any case not over the ISI);
- facility, since ANF-ISISS is used instead (see clauses 9 and 10 of EN 300 392-9 [6]).

In addition the following information elements have been added:

- originating SwMI MNI;
- call has been forward switched;
- last forwarding SWMI MNI;
- routeing method choice;
- forwarding counter;
- call time-out, set-up phase;
- security level (used) at calling user air interface;
- speech service requested;
- speech services supported;
- called/forwarded-to party address SSI and called/forwarded-to party extension;
- number of digits in called/forwarded-to external subscriber number;

- called/forwarded-to external subscriber number;
- calling party presentation indicator;
- (calling party) MSISDN present as external subscriber number;
- calling external subscriber number parameters;
- call identified as fleet call;
- calling party fleet number SSI;
- called/forwarded-to party fleet number SSI.

In addition the calling external subscriber number is being encoded in a different manner which uses less bits.

NOTE 2: The originating SwMI MNI information element has been included in the definition of the TETRA PDU in table 27 to ease the identification of the originating SwMI for the called SwMI or the terminating SwMI (because to do it using the PISN number put in the calling party number information element of the PSS1 SETUP message, as specified in clause 6.2.1, might have proven problematic in some cases).

Such identification is necessary:

- for enforcing some security mechanisms agreed between operators; or
- to be able to identify whether a proprietary feature can or cannot be used over an ISI; or
- to allow loop connection (notably trombone connection) detection.

NOTE 3: The information element last forwarding SwMI MNI is only needed for the routeing operation of the call forwarding supplementary services by the invoked ANF-ISIIC. In addition, even when no call forwarding supplementary service is invoked for the called user, it is helpful for the terminating SwMI to identify that the call has been routed by forward switching through the home SwMI of the called user when that SwMI is SwMI B and that user has migrated (to SwMI C, the terminating SwMI).

The information element forward switched allows not to include the information element last forwarding SwMI MNI when the call has not been forward switched.

The information element SS-CF invocation counter is present only because of the interactions between the call forwarding supplementary services and ANF-ISIIC: to limit the number of invocations (and operations) of those supplementary services for the same call.

NOTE 4: See clauses 6.3.2.2.42 and 6.3.2.2.46 for the definitions of the information elements routeing method choice and speech services supported, respectively.

NOTE 5: The Call time-out information element indicates the suggested value for T310.

### 6.3.1.2 TETRA PDU giving complementary information in a PSS1 PROGRESS message

According to clause 10 of ISO/IEC 11572 [9], a PROGRESS message will only be sent in the case of interworking with a non-TETRA network, i.e. in the case of an external call (since no SwMI involved in the call set-up will send in-band information/patterns otherwise). The contents of TETRA PDU in this message and its encoding shall be as defined in table 28.

**Table 28: Contents of TETRA PDU sent in PSS1 PROGRESS message**

Information element	Length	Type	Owner	C/O/M	Remark
PDU type	6	1	CCAp	M	ISI-PROGRESS
Call time-out, set-up phase	3	1	CCAp	M	
Hook method selection	1	1	CCAp	M	
Simplex/duplex selection	1	1	CCAp	M	
Call status	3	2	CCAp	O	
Basic service information	8	2	CCAp	O	(see note)
Speech service chosen	3	2	CCAp	O	(see note)
Notification indicator	6	2	SS	O	
Proprietary		3	-	O	
NOTE:	Mandatory when it is different from requested and when this information element has not already been sent. Otherwise, this information element shall not be included.				

NOTE: The definition of this PDU has been done on the basis of that of the D-CALL PROCEEDING air interface downlink PDU - except for the addition of the optional information element defining the speech service chosen and the deletion of the facility information element.

### 6.3.1.3 TETRA message sent by the called SwMI in a PSS1 FACILITY message when it is not the terminating SwMI because of migration or SS-CF invocation

When no call forwarding supplementary service is invoked for the call, the called SwMI is different from the terminating SwMI only when:

- it (i.e. the called SwMI) is the home SwMI of the called user; and
- the called user has migrated.

The called SwMI may also be different from the terminating SwMI as a result of the operation of a call forwarding supplementary service invoked for the call.

The called SwMI will then send to the originating SwMI a PSS1 FACILITY message including a TETRA PDU, the contents and the encoding of which shall be as defined in table 29.

**Table 29: Contents of TETRA PDU sent by the called SwMI in a PSS1 FACILITY message in case it is not the terminating SwMI because of migration of the called user or of SS-CF invocation**

Information element	Length	Type	Owner	C/O/M	Remark
PDU-Type	6	1	CCAp	M	ISI-REDIRECT
Possible ISI trombone or loop connection detected	1	1	ANF	M	(see note 1)
Routeing method response	3		ANF	C	(see note 2)
Called/forwarded-to user having migrated	1		ANF	C	(see note 2)
Visited/forwarded-to SwMI MNI	24		ANF	C	(see note 3)
Number of digits in visited/forwarded-to SwMI PISN number	5		ANF	C	(see notes 3 and 4)
Visited/forwarded-to SwMI PISN number	variable		ANF	C	(see notes 3 and 5)
SS-CF invocation counter	5	1	SS	M	
SS-CF invoked	1	1	SS	M	(see note 6)
Forwarded-to user SSI	24		SS	C	(see note 7)
Forwarded-to user extension	24		SS	C	(see note 7)
Number of digits in forwarded-to external subscriber number	5		SS	C	(see notes 7 and 8 )
Forwarded-to external subscriber number	variable		SS	C	(see note 9)
Call identified as fleet call	1	1	CCAp	M	
Calling party fleet number SSI	24		CCAp	C	(see note 10)
Called/forwarded-to party fleet number SSI	24		CCAp	C	(see note 10)
PDU addressed to originating SwMI	1	1	ANF	M	(see note 11)
Cause for PDU addressed to originating SwMI	3		ANF	C	(see note 12)
Incoming call barring status	2		ANF	C	(see notes 12 and 13)
Notification indicator	6	2	SS	O	
Proprietary		3	-	O	

NOTE 1: If no SS-CF has been invoked, the only possible case of ISI trombone or loop connection which can occur is when the called party has migrated into the originating SwMI. Actually in such a case, only an ISI trombone connection could occur if the call was forward switched in the SwMI which sends this ISI-REDIRECT PDU. If SS-CF has been invoked and the call forward switched at least once, the cases which can occur and be detected by the SwMI which sends this ISI-REDIRECT PDU are the following:

- an ISI trombone connection with the preceding SwMI (i.e. the one which has sent the corresponding ISI-SETUP PDU); or
- an ISI loop connection with the originating SwMI (possibly reduced to a trombone if the connection with the originating SwMI was established backwards through all the same SwMIs already on the path).

The SwMI which sends this ISI-REDIRECT PDU shall detect the above cases of ISI trombone or loop connection with the originating SwMI. If it detects such possible ISI loop (else trombone - see above) connection with the originating SwMI in the case where SS-CF has been invoked and the call forward switched at least once, it shall then send this ISI-REDIRECT PDU directly to the originating SwMI (see clause 6.3.3). In addition, it should detect the possible ISI trombone connection with the preceding SwMI when that SwMI is different from the originating SwMI, i.e. in the case where SS-CF has been invoked and the call forward switched at least once.

NOTE 2: Conditional on the value of the information element "Possible ISI trombone or loop connection detected" indicating that the SwMI by the SwMI sending this ISI-REDIRECT PDU has not detected the possibility of such ISI trombone or loop connection.

If such an ISI trombone connection with the preceding SwMI could occur but this had not been detected by the SwMI sending this ISI-REDIRECT PDU (i.e. that SwMI is different from the originating SwMI), that preceding SwMI (which receives this PDU) may avoid it by identifying the MNI in this information element as being its own.

NOTE 3: Conditional on the value of the information element "called/forwarded-to user having migrated" indicating:

- if no SS-CF is invoked, that the called user (or the SS-CF served user if SS-CF has been invoked previously) has migrated;
- if SS-CF is invoked, that the forwarded-to user has migrated.

Note that in either case, the case where such migration would take place into the originating SwMI will be excluded since in that case the information element "called/forwarded-to user having migrated" shall not be present (see note 2).

NOTE 4: Shall be equal to N, N being the number of digits which the visited/forwarded-to SwMI PISN number comprises.

NOTE 5:	The length in bits of this information element shall be equal to $4 \times N$ , N being the number of digits in the visited/forwarded-to SwMI PISN number (see note 4).
NOTE 6:	Allows to distinguish between migration of the called user indicated in the corresponding ISI-SETUP PDU and operation of a call forwarding supplementary service invoked in the SwMI sending this ISI-REDIRECT PDU; if SS-CF has been invoked, if the SwMI sending this ISI-REDIRECT PDU is the forwarded-to user and if that user has migrated, this PDU shall contain elements pertaining to both.
NOTE 7:	Conditional on the value of the information element SS-CF invoked indicating that such SS-CF information is present.
NOTE 8:	Shall be equal to 0 when no forwarded-to external subscriber number is present, or to N, N being the number of digits which the forwarded-to external subscriber number comprises.
NOTE 9:	The length in bits of this information element shall be equal to $4 \times N$ , N being the number of digits in the forwarded-to external subscriber number (see note 8), i.e. this information element shall be conditional on the value of N.
NOTE 10:	Conditional on the value of the information element call identified as fleet call indicating that the call has been identified as being a fleet call.
NOTE 11:	The value of this information element shall correspond to the addressing of this ISI-REDIRECT PDU to the originating SwMI: <ul style="list-style-type: none"> <li>- in the cases of possible ISI trombone or loop connection with the originating SwMI as provided in note 1 above; or</li> <li>- in the specific cases of SS-CF served user migration in the originating SwMI identified by specific values of the following information element: cause for PDU addressed to originating SwMI.</li> </ul>
NOTE 12:	Conditional on the value of the information element "PDU addressed to originating SwMI" indicating that this ISI-REDIRECT PDU is addressed to the originating SwMI.
NOTE 13:	Conditional on the binary value of the information element cause for PDU addressed to originating SwMI being smaller than 011 <sub>2</sub> . It shall then apply to the called user (or if SS-CF has been invoked, to the SS-CF served user) - to take into account the interactions with local SS-BIC and SS-CAD.

#### 6.3.1.4 TETRA message sent by the originating SwMI in a PSS1 FACILITY message to request forward switching

After having received the PSS1 FACILITY message defined in table 29 (whereby the called SwMI informs the originating SwMI that the call has to be re-directed to a third SwMI), the originating SwMI may decide to have the call forward switched in the called SwMI. It will then send a PSS1 FACILITY message including a TETRA PDU, the contents and the encoding of which shall be as defined in table 30.

**Table 30: Contents of TETRA PDU possibly sent by the originating SwMI in a PSS1 FACILITY message in response to ISI-REDIRECT PDU**

Information element	Length	Type	Owner	C/O/M	Remark
PDU type	6	1	CCAp	M	ISI-FORWARD SWITCH
Proprietary		3	-	O	

### 6.3.1.5 TETRA PDU giving complementary information in the PSS1 ALERTING message

The contents of this PDU and its encoding shall be as defined in table 31.

**Table 31: Contents of TETRA PDU sent in the PSS1 ALERTING message**

Information element	Length	Type	Owner	C/O/M	Remark
PDU type	6	1	CCAp	M	ISI-ALERTING
Call time-out, set-up phase	3	1	CCAp	M	
Reserved	1	1	CCAp	M	(see note 3)
Simplex/duplex selection	1	1	CCAp	M	
Call status	4	2	CCAp	O	(see note 1)
Basic service information	8	2	CCAp	O	(see note 2)
Speech service chosen	3	2	CCAp	O	(see note 2)
Notification indicator	6	2	SS	O	
Proprietary		3	-	O	

NOTE 1: If present this information element shall take only the values corresponding to call queued or call waiting (the latter corresponding to SS-CW being invoked by the called user).

NOTE 2: Mandatory when it is different from requested or from that already sent in another TETRA PDU (i.e. in a PSS1 FACILITY or PROGRESS message). Otherwise, this information element shall not be included.

NOTE 3: The value of the reserved information element shall be set to "0".

### 6.3.1.6 TETRA PDU giving complementary information in the PSS1 CONNECT message

The contents of this PDU and its encoding shall be as defined in table 32.

**Table 32: Contents of TETRA PDU sent in the PSS1 CONNECT message**

Information element	Length	Type	Owner	C/O/M	Remark
PDU type	6	1	CCAp	M	ISI-CONNECT
Terminating SwMI MNI	24	1	ANF	M	
Call diverted to a dispatcher	1	1	ANF	M	
Call time-out	4	1	CCAp	M	
Hook method selection	1	1	CCAp	M	
Simplex/duplex selection	1	1	CCAp	M	
Call ownership	1	1	CCAp	M	(see note 2)
Security level at calling user air interface	2	1	MM	M	
Resource indicator	2	1	CCAp	M	
Setup resource allocation	1	1	CCAp	M	
Connected party presentation indicator	2	1	SS	M	
Connected party SSI	24	1	CCAp	M	(see note 3)
Connected party extension	24	1	CCAp	M	(see note 4)
Number of digits in connected external subscriber number	5	1	CCAp	M	(see note 5)
Connected external subscriber number	variable		CCAp	C	(see note 6)
MSISDN present as external subscriber number	1		CCAp	C	(see note 7)
Connected external subscriber number parameters	9		CCAp	C	(see note 7)
Call identified as fleet call	1	1	CCAp	M	
Connected party fleet number SSI	24		CCAp	C	(see note 8)
Call priority	4	2	CCAp	O	(see note 9)
Basic service information	8	2	CCAp	O	(see note 9)
Speech service chosen	3	2	CCAp	O	(see note 9)



Information element	Length	Type	Owner	C/O/M	Remark
Notification indicator	6	2	SS	O	
Proprietary		3	-	O	
NOTE 1: Void. NOTE 2: This element is needed in the case of call collision. NOTE 3: In the case of an external outgoing call, the connected party SSI shall be that of the outgoing gateway SwMI. NOTE 4: In the case of an external outgoing call, the connected party extension shall be that of the outgoing gateway SwMI. NOTE 5: Shall be equal to 0 when no connected external subscriber number is available or applicable, or to N, N being the number of digits which the connected external subscriber number comprises. NOTE 6: The length in bits of this information element shall be equal to $4 \times N$ , N being the number of digits in the external subscriber number (see note 5), i.e. this information element shall be conditional on the value of N. NOTE 7: Conditional on the value of the information element number of digits in connected external subscriber number being different from 0. NOTE 8: Conditional on the value of the information element call identified as fleet call indicating that the call has been identified as being a fleet call. NOTE 9: Mandatory when it is different from requested or from that already sent in another TETRA PDU. Otherwise, this information element shall not be included.					

NOTE 1: The term "connected party" has been preferred to "called party" in the definition of two information elements in table 32 to be aligned with the definition of the PSS1 CONNECT message, in clause 13.2.3 of ISO/IEC 11572 [9]. It anticipates possible interactions with supplementary services which modify the addressee of the call (e.g. supplementary services call forwarding or call authorized by dispatcher). In the absence of such interaction, the connected party will be the called party.

NOTE 2: The Security level at calling user air interface information element value can be different from the value received in the ISI-Setup when the Terminating SwMI wishes to downgrade air interface encryption.

NOTE 3: The Call time-out can be different to the value suggested in the ISI-Setup if the Terminating SwMI wishes to use a different value to that suggested by the Originating SwMI.

NOTE 4: The Resource indicator information element indicates if all radio traffic channel resources needed to connect the called party are available or not. The ISI-CONNECT PDU is sent by the Called/Visited SwMI as soon as an attempt is made to get the radio traffic channel resources in a "late assignment" call. If the resources are immediately available then this field carries the value "resources are reserved" if they are not immediately available then the ISI-CONNECT PDU is still sent but the field contains the value "resources could not be reserved, delay requested". This prevents serial queuing by allowing the Originating SwMI to start queuing for its radio traffic channel resources at virtually the same time as the Called/Visited SwMI is also queuing. It also allows both call parties to be informed of the queuing situation. If an ISI-CONNECT PDU is sent that contains "resources could not be reserved, delay requested" then once the radio traffic channel resources become available an ISI-RESOURCE-RESPONSE PDU indicating that "resources are reserved" is sent.

NOTE 5: The Setup resource allocation information element indicates the allocation policy that is used by the Called/Visited SwMI for its radio traffic channel resources:

- "setup permanently allocated resources" means that, once allocated, a radio traffic channel is not released until the call is cleared;
- "setup temporary allocated resources" means that, once allocated, radio traffic channel resources are eligible for release if an ISI-QUEUING PDU, not forbidding the release of resources, is received.

Although the radio traffic channel resource is eligible for release the actual policy used for releasing the traffic channel resource is implementation specific. For example, once eligible for release a SwMI may release the channel immediately, release it only if required by another call, release it after a timeout or use some other criteria.

The Originating SwMI assumes that the radio traffic channel resources are eligible for release in the Called/Visited SwMI only when an ISI-QUEUING PDU has been sent. It is possible (although not recommended), in exceptional circumstances, for the Called/Visited SwMI to release its radio traffic channel resources at other times and still allow the call to continue. However it should take account of the fact that the Originating SwMI believes it still has its resources. If the Originating SwMI tries to connect the call but the Called/Visited SwMI has used these exceptional procedures to release its radio traffic channel resources then it will attempt to reacquire its radio traffic channel resources immediately and if they cannot be obtained clear the call.

Once the Called/Visited SwMI has obtained its radio traffic channel resources and indicated this to the Originating SwMI (in either an ISI-CONNECT PDU or an ISI-RESOURCE-RESPONSE PDU) then the Originating SwMI will as soon as is practically possible either connect the call (with an ISI-CONNECT-ACKNOWLEDGE) or further delay the call (with ISI-QUEUING). This is to ensure that the Called/Visited SwMI is kept in a state where it cannot naturally release its radio traffic channel resources for the smallest possible time.

An Originating SwMI operating a policy of temporary radio traffic channel resource allocation makes its radio traffic channel resources eligible for release when there is queuing in the call (i.e. when it has sent an ISI-QUEUING PDU). Again the actual policy for the release of the traffic channel is implementation specific.

Once a call has entered its maintenance phase radio traffic channel resources are always permanently allocated.

### 6.3.1.7 TETRA information sent by the terminating SwMI in PSS1 FACILITY messages before the PSS1 ALERTING or CONNECT message

The terminating SwMI may inform the originating SwMI about some characteristics requested in the set-up that it does not support before the PSS1 ALERTING or CONNECT message has been sent. It will do this by sending a TETRA PDU in a PSS1 FACILITY message, the contents and the encoding of which shall be as defined in table 33.

Such PSS1 FACILITY message including this same TETRA PDU may also be sent by a SwMI outgoing gateway, instead of the PSS1 PROGRESS message including the TETRA PDU defined in table 28.

**Table 33: Contents of TETRA PDU (possibly) sent in a PSS1 FACILITY message**

Information element	Length	Type	Owner	C/O/M	Remark
PDU type	6	1	CCAp	M	ISI-CALL PROCEEDING
Call time-out, set-up phase	3	1	CCAp	M	
Simplex/duplex selection	1	1	CCAp	M	
Call status	3	2	CCAp	O	
Basic service information	8	2	CCAp	O	see note
Speech service chosen	3	2	CCAp	O	see note
Notification indicator	6	2	SS	O	
Proprietary		3	-	O	
NOTE: Mandatory when it is different from requested. Otherwise, this information element shall not be included.					

NOTE 1: Except for the value of the PDU type information element and for the absence of the information element hook method selection, this PDU definition is the same as that in table 28.

NOTE 2: The information element hook method selection has not been included in table 33, because only the called user may decide which hook method it selects.

NOTE 3: The SwMI restarts the "Call time-out, set-up phase" timer when this PDU is received.

If the terminating SwMI decides to prolong the call set-up time on its side while no other information is to be sent to the originating SwMI, it may send a PSS1 FACILITY message including a TETRA PDU, the contents and the encoding of which shall be as defined in table 34.

**Table 34: Contents of TETRA PDU (possibly) sent in a PSS1 FACILITY message to inform about prolongation of the call set-up time**

Information element	Length	Type	Owner	C/O/M	Remark
PDU type	6	1	CCAp	M	ISI-SETUP PROLONGATION
Call time-out, set-up phase	3	1	CCAp	M	
Notification indicator	6	2	SS	O	
Proprietary		3	-	O	

NOTE 4: The SwMI restarts the "Call time-out, set-up phase timer" when this PDU is received.

#### 6.3.1.8 TETRA information sent by the terminating SwMI in a PSS1 FACILITY message during call establishment after the PSS1 ALERTING or CONNECT message

If the terminating SwMI decides to prolong the call set-up time on its side after the PSS1 ALERTING or CONNECT message has been sent (but of course before the call has been established - i.e. it has not yet sent the D-CONNECT ACKNOWLEDGE air interface downlink PDU), it will send a PSS1 FACILITY message including the same TETRA PDU as if it would if it had taken this decision before sending the PSS1 ALERTING message if the call is using on/off hook signalling, or the PSS1 CONNECT message if is using direct set-up signalling (i.e. the same TETRA PDU as defined in table 34).

#### 6.3.1.9 TETRA information sent by the originating SwMI in a PSS1 FACILITY message before the call has been established

If the originating SwMI decides to prolong the call set-up time on its side, it will send a PSS1 FACILITY message including a TETRA PDU, the contents and the encoding of which shall be as defined in table 34.

#### 6.3.1.10 TETRA CONNECT ACKNOWLEDGE sent by the originating SwMI in a PSS1 FACILITY message

To acknowledge the PSS1 CONNECT message (in guaranteeing that a radio traffic channel has been to the calling user), the originating SwMI will send an ISI-CONNECT ACKNOWLEDGE PDU. This will be done using a PSS1 FACILITY message including a TETRA PDU, the contents and the encoding of which shall be as defined in table 35.

**Table 35: Contents of TETRA PDU sent in a PSS1 FACILITY message to acknowledge the CONNECT message (CONNECT ACKNOWLEDGE)**

Information element	Length	Type	Owner	C/O/M	Remark
PDU type	6	1	CCAp	M	ISI-CONNECT ACKNOWLEDGE
Call time-out	4	1	CCAp	M	
Transmission grant	2	1	CCAp	M	
Transmission request permission	1	1	CCAp	M	
Notification indicator	6	2	SS	O	
Proprietary		3	-	O	
NOTE:	The "Call time-out" information element contains the value of T310 to be used in the call considering the original requested value sent in the ISI-Setup and the possibly modified value sent back in the ISI-Connect.				

#### 6.3.1.11 Other TETRA messages possibly sent by the originating SwMI in PSS1 FACILITY messages

To inform the terminating SwMI that permission to transmit has been granted to the connected user, the originating SwMI will send an ISI-TX GRANTED PDU. This shall be done using a PSS1 FACILITY message including a TETRA PDU, the contents and the encoding of which shall be as defined in table 36.

**Table 36: Contents of TETRA PDU sent in a PSS1 FACILITY message to grant transmission permission (ISI-TX GRANTED)**

Information element	Length	Type	Owner	C/O/M	Remark
PDU Type	6	1	CCAp	M	ISI-TX GRANTED
Transmission grant	2	1	CCAp	M	
Transmission request permission	1	1	CCAp	M	
Encryption control	1	1	CCAp	M	
Notification indicator	6	2	SS	O	
Proprietary		3	-	O	

To inform the terminating SwMI that the connected user is to be interrupted by the calling user, the originating SwMI will send an ISI-TX INTERRUPT PDU. This shall be done using a PSS1 FACILITY message including a TETRA PDU, the contents and the encoding of which shall be as defined in table 37.

**Table 37: Contents of TETRA PDU sent in a PSS1 FACILITY message to interrupt transmission by the connected user (ISI-TX INTERRUPT)**

Information element	Length	Type	Owner	C/O/M	Remark
PDU Type	6	1	CCAp	M	ISI-TX INTERRUPT
Transmission grant	2	1	CCAp	M	
Transmission request permission	1	1	CCAp	M	
Encryption control	1	1	CCAp	M	
Notification indicator	6	2	SS	O	
Proprietary		3	-	O	

NOTE 1: The definitions of the ISI-TX GRANTED and ISI-TX INTERRUPT PDUs in tables 36 and 37 have been simplified compared to those of the corresponding air interface D-TX GRANTED and D-TX INTERRUPT PDUs. Notably, those ISI PDUs do not include the following information elements:

- the information elements identifying the transmitting party, because there are only useful for a group call and the goal of aligning ANF-ISIGC PDUs with the corresponding ANF-ISIIC ones has been abandoned;
- the facility information element, as in every other ISI PDUs, since, as already mentioned in note 1 of clause 6.3.1.1, ANF-ISISS is used instead (see clauses 9 and 10 of EN 300 392-9 [6]).

To inform the terminating SwMI that transmission has ceased and that the called user may request transmission permission, the originating SwMI will send an ISI-TX CEASED PDU. This shall be done using a PSS1 FACILITY message including a TETRA PDU, the contents and the encoding of which shall be as defined in table 38.

NOTE 2: The PDU name ISI-TX CEASED IN ORIGINATING SwMI is used to indicate PDU sent by the controlling SwMI.

**Table 38: Contents of TETRA PDU sent in a PSS1 FACILITY message by the originating SwMI to inform that transmission has ceased (ISI-TX CEASED IN ORIGINATING SwMI)**

Information element	Length	Type	Owner	C/O/M	Remark
PDU Type	6	1	CCAp	M	ISI-TX CEASED IN ORIGINATING SwMI
Transmission request permission	1	1	CCAp	M	
Notification indicator	6	2	SS	O	
Proprietary		3	-	O	

To inform the terminating SwMI regarding continuation of transmission (after it has been interrupted), the originating SwMI will send an ISI-TX CONTINUE PDU. This shall be done using a PSS1 FACILITY message including a TETRA PDU, the contents and the encoding of which shall be as defined in table 39.

NOTE 3: The PDU name ISI-TX CONTINUE IN ORIGINATING SwMI is used to indicate PDU sent by the controlling SwMI.

**Table 39: Contents of TETRA PDU sent in a PSS1 FACILITY message by the originating SwMI on transmission continuation (ISI-TX CONTINUE IN ORIGINATING SwMI)**

Information element	Length	Type	Owner	C/O/M	Remark
PDU Type	6	1	CCAp	M	ISI-TX CONTINUE IN ORIGINATING SwMI
Continue	1	1	CCAp	M	
Transmission request permission	1	1	CCAp	M	
Notification indicator	6	2	SS	O	
Proprietary		3	-	O	

### 6.3.1.12 TETRA messages possibly sent by either the originating or the terminating SwMI in a PSS1 FACILITY message

To inform the other end SwMI that it has interrupted transmission, the originating or the terminating SwMI will send an ISI-TX WAIT PDU. This shall be done using a PSS1 FACILITY message including a TETRA PDU, the contents and the encoding of which shall be as defined in table 40. When the terminating SwMI sends the ISI-TX WAIT PDU, then it shall set the Transmission request permission to value "Allowed to request for transmission" and the originating (controlling) SwMI shall ignore its content.

**Table 40: Contents of TETRA PDU sent in a PSS1 FACILITY message to interrupt transmission (ISI-TX WAIT)**

Information element	Length	Type	Owner	C/O/M	Remark
PDU Type	6	1	CCAp	M	ISI-TX WAIT
Transmission request permission	1	1	CCAp	M	
Notification indicator	6	2	SS	O	
Proprietary		3	-	O	

To inform the other end SwMI that it wants some call modification or simply call continuation (both as specified in clause 14.5.1.2 of EN 300 392-2 [1]) and/or to send DTMF information and/or notifications, the originating or the terminating SwMI will send an ISI-"INFO" DEMAND PDU. This shall be done using a PSS1 FACILITY message including a TETRA PDU, the contents and the encoding of which shall be as defined in table 41.

**Table 41: Contents of TETRA PDU sent in a PSS1 FACILITY message to request some call modification (ISI-"INFO" DEMAND)**

Information element	Length	Type	Owner	C/O/M	Remark
PDU Type	6	1	CCAp	M	ISI-INFO DEMAND
Call time-out	4	2	CCAp	O	(see note 1)
Modify request	9	2	CCAp	O	
Speech service requested/chosen	3	2	CCAp	O	(see notes 2 and 3)
Speech services supported	8	2	CCAp	O	(see note 4)
Notification indicator	6	2	SS	O	
Call status	4	2	SS	O	(see note 5)
DTMF	variable	3	CCAp	O	
Proprietary		3	-	O	
<p>NOTE 1: Shall only be sent if the sending SwMI has decided to change the duration of the call in updating the equivalent information element to the user that it controls (by a D-INFO air interface PDU).</p> <p>NOTE 2: Mandatory if the value of the information element modify request corresponds to a change from a data call to a speech call. Also mandatory to change the speech service during a speech call. Otherwise, this information element shall not be included.</p> <p>NOTE 3: The meaning of this information element is speech service chosen when this PDU is used instead of ISI-ALERTING PDU (see e.g. SS-CAD).</p> <p>NOTE 4: May be present only when the information element speech service requested(/chosen) is present (see note 2).</p> <p>NOTE 5: This information element is used by the SS-CFNRY, SS-CAD, SS-CW and SS-HOLD protocols (only with the value corresponding to call queued by the SS-CFNRY protocol, with the value corresponding to call waiting by the SS-CW protocol and with the values corresponding to call put on hold and call on hold retrieved by the SS-HOLD protocol).</p>					

If the contents of the TETRA PDU defined in table 41 calls for a response, upon receiving the PSS1 FACILITY message including it, the other end SwMI will send a PSS1 FACILITY message including a TETRA PDU, the contents and the encoding of which shall be as defined in table 42.

**Table 42: Contents of TETRA PDU sent in a PSS1 FACILITY message in reply to a call modification request (ISI-"INFO" REPLY)**

Information element	Length	Type	Owner	C/O/M	Remark
PDU Type	6	1	CCAp	M	ISI-INFO REPLY
Call time-out	4	2	CCAp	O	(see note 1)
Modify accepted	9	2	CCAp	O	(see note 2)
Speech service chosen	3	2	CCAp	O	(see note 3)
Notification indicator	6	2	SS	O	
DTMF		3	CCAp	O	
Proprietary		3	-	O	
NOTE 1: Mandatory when it is different from that sent by the other end SwMI in the preceding ISI-INFO DEMAND PDU. Otherwise, this information element shall not be included.					
NOTE 2: Mandatory when it is different from requested. Otherwise, this information element shall not be included.					
NOTE 3: Mandatory when it is different from that sent by the other end SwMI in the preceding ISI-INFO DEMAND PDU. Otherwise, this information element shall not be included.					

NOTE: The DTMF information element is used when the DTMF digits in the ISI-INFO DEMAND PDU are not supported or subscribed. The DTMF digits themselves are never returned.

### 6.3.1.13 TETRA messages possibly sent by the terminating SwMI in PSS1 FACILITY messages

To request transmission grant from the originating SwMI, the terminating SwMI will send an ISI-TX DEMAND PDU. This shall be done using a PSS1 FACILITY message including a TETRA PDU, the contents and the encoding of which shall be as defined in table 43.

**Table 43: Contents of TETRA PDU sent in a PSS1 FACILITY message to request transmission grant (ISI-TX DEMAND)**

Information element	Length	Type	Owner	C/O/M	Remark
PDU Type	6	1	CCAp	M	ISI-TX DEMAND
TX demand priority	2	1	CCAp	M	
Encryption control	1	1	CCAp	M	
Notification indicator	6	2	SS	O	
Proprietary		3	-	O	

NOTE 1: The definition of the ISI-TX DEMAND PDU in table 43 has been derived from that of the corresponding air interface U-TX DEMAND PDU in:

- removing the information elements:
  - call identifier (specific to air interface PDUs);
  - DM-MS address (specific to some air interface PDUs - used for Direct Mode Operation);
  - facility, as in every other ISI PDUs, since, as already mentioned in note 1 of clause 6.3.1.1, ANF-ISISS is used instead (see clauses 9 and 10 of EN 300 392-9 [6]); and
  - the 1 bit reserved one; and
  - adding the notification indicator information element.

To inform the originating SwMI that transmission has ceased, the terminating SwMI will send an ISI-TX CEASED PDU. This shall be done using a PSS1 FACILITY message including a TETRA PDU, the contents and the encoding of which shall be as defined in table 44.

NOTE 2: The PDU name ISI-TX CEASED IN TERMINATING SwMI is used to indicate PDU sent by the non-controlling SwMI.

**Table 44: Contents of TETRA PDU sent in a PSS1 FACILITY message to inform that transmission has ceased (ISI-TX CEASED IN TERMINATING SwMI)**

Information element	Length	Type	Owner	C/O/M	Remark
PDU Type	6	1	CCAp	M	ISI-TX CEASED IN TERMINATING SwMI
Notification indicator	6	2	SS	O	
Proprietary		3	-	O	

To inform the originating SwMI that it is ready to continue transmission (after having interrupted it), the terminating SwMI will send an ISI-TX CONTINUE PDU. This shall be done using a PSS1 FACILITY message including a TETRA PDU, the contents and the encoding of which shall be as defined in table 45.

NOTE 3: The PDU name ISI-TX CONTINUE IN TERMINATING SwMI is used to indicate PDU sent by the non-controlling SwMI.

**Table 45: Contents of TETRA PDU sent in a PSS1 FACILITY message by the terminating SwMI on transmission continuation (ISI-TX CONTINUE IN TERMINATING SwMI)**

Information element	Length	Type	Owner	C/O/M	Remark
PDU Type	6	1	CCAp	M	ISI-TX CONTINUE IN TERMINATING SwMI
Notification indicator	6	2	SS	O	
Proprietary		3	-	O	

#### 6.3.1.14 TETRA PDUs giving complementary information in PSS1 messages to restore the call after the calling or the connected user has migrated in a new SwMI

When one of the two users participating in an established individual call migrates during this call, the call control application in the SwMI in which this user was previously registered will be informed by ANF-ISIMM about this migration. This information will include the MNI of the new SwMI where the user is now registered and may include the PISN number to be used for establishing a connection between the old SwMI and that new SwMI, to allow a subsequent call restoration, unless such connection already exists because the new SwMI coincides with either the other end SwMI (i.e. either the originating or the terminating SwMI) or the forward switching SwMI. If such PISN number is not delivered by ANF-ISIMM, then the old SwMI will use the PISN number corresponding to the new SwMI MNI in its routing table.

### 6.3.1.14.1 Case where no connection between the old SwMI and the new SwMI already exists or has been identified

If the connection between the old SwMI and the new SwMI does not already exist or has not been identified, it may be set-up by the ANF-ISIIC entity in the old SwMI. If the call was an inter-TETRA call, this will be part of the operation of the ANF-ISIIC invoked for that call. If the established call was an intra-TETRA call, an ANF-ISIIC will be invoked to establish this connection. In both cases, the old SwMI will send a PSS1 SETUP message including a TETRA PDU, the contents and the encoding of which shall be as defined in table 46.

**Table 46: Contents of TETRA PDU in PSS1 SETUP message sent by the old SwMI in the case of migration during an established call**

Information element	Length	Type	Owner	C/O/M	Remark
PDU type	6	1	CCAp	M	ISI-CALL RESTORE PREPARE
Other end SwMI MNI	24	1	ANF	M	
Call time-out	4	1	CCAp	M	
Simplex/duplex selection	1	1	CCAp	M	
Basic service information	8	1	CCAp	M	
Speech service used	3		CCAp	C	(see note 1)
Security level at calling user air interface	2	1	MM	M	(see notes 2 and 3)
Controlling SwMI	1	1	CCAp	M	
Transmission grant	2	1	CCAp	M	
Transmission request permission	1	1	CCAp	M	
Call priority	4	1	CCAp	M	
Call identifier	14	1	CCAp	M	
Restoring party SSI	24	1	CCAp	M	(see note 4)
Restoring party extension	24	1	CCAp	M	(see note 4)
SS-CLIR invoked for other party	1	1	SS	M	
Other party SSI	24	1	CCAp	M	(see note 5)
Other party extension	24	1	CCAp	M	(see note 5)
Speech services supported	8	2	CCAp	O	(see note 6)
Proprietary		3	-	O	
NOTE 1: Conditional on the binary value of the information sub-element circuit mode type in the information element basic service information being equal to 0 (i.e. the call requested is a speech call).					
NOTE 2: This information element, which defines the security level that the originating SwMI requested at call set-up time the terminating SwMI to match, is sent independently of whether the "old SwMI" is the originating SwMI or the terminating SwMI.					
NOTE 3: In the case of an external incoming call from PSTN/ISDN/PISN, the name of this information element should be understood as "security level used in the other network".					
NOTE 4: The case where the restoring party SSI and the restoring party extension would be those of a gateway is excluded.					
NOTE 5: In the case of an external call, the other party SSI and the other party extension shall be those of the gateway.					
NOTE 6: May be present only when the information element speech service requested is present (see note 1).					

NOTE: The two information elements defining the restoring party ITSI have been included in the table above because it was felt that the call identifier value included in this table might not always allow the new SwMI to associate the connection being established to this party when it restores the call (especially since the call identifier value included in this table is not a new SwMI call identifier).

As to the two information elements defining the other party ITSI, they have been included to support the redundancy mechanism provided by the inclusion of these elements in the definition of the air interface U-CALL RESTORE message (see table 78 of EN 300 392-2 [1]).

To indicate that it accepts the PSS1 SETUP message, if it has not yet received the call restoration message from its new visiting user, the new SwMI will send a PSS1 CONNECT message including only a specific PDU type as defined in table 47.

**Table 47: Contents of TETRA PDU sent in the PSS1 CONNECT message**

Information element	Length	Type	Owner	C/O/M	Remark
PDU type	6	1	CCAp	M	ISI-CALL RESTORE PREPARED



Then, when the new SwMI receives the call restoration message from its new visiting user, it will send a PSS1 FACILITY message including a TETRA PDU, the contents and the encoding of which shall be as defined in table 48.

**Table 48: Contents of TETRA PDU in PSS1 FACILITY message sent by the new SwMI in the case of call restoration**

Information element	Length	Type	Owner	C/O/M	Remark
PDU type	6	1	CCAp	M	ISI-CALL RESTORATION
New SwMI MNI	24	1	ANF	M	
Controlling SwMI	1	1	CCAp	M	
Transmission grant	2		CCAp	C	(see note 1)
Transmission request permission	1		CCAp	C	(see note 1)
Call time-out	4	2	CCAp	O	(see note 2)
Call status	4	2	CCAp	M	(see note 3)
Call priority	4	2	CCAp	O	(see note 2)
Modify request	9	2	CCAp	O	(see note 4)
Speech service chosen	3	2	CCAp	O	(see note 5)
Notification indicator	6	2	SS	O	
Proprietary		3	-	O	
NOTE 1: This information element shall be included if and only if the value of the information element controlling SwMI is equal to 1 (i.e. if the new SwMI is going to be the controlling SwMI - for the call).					
NOTE 2: Mandatory when the new SwMI has modified the value of this information element compared to that passed by the old SwMI in the corresponding ISI-CALL RESTORE PREPARE PDU or ISI-PATH CALL RESTORE PREPARE PDU. Otherwise, this information element shall not be included.					
NOTE 3: If present this information element shall take only the values corresponding to call queued or call on hold retrieved (the latter being possibly used only by the SS-HOLD protocol).					
NOTE 4: Mandatory when the new SwMI has modified the simplex/duplex selection or the basic service information of the call before the party restoring it migrated (i.e. when the simplex/duplex selection or the basic service information between the old SwMI and the other end SwMI have been modified by the new SwMI - that SwMI being informed about those used previously by the corresponding ISI-CALL RESTORE PREPARE PDU or ISI-PATH CALL RESTORE PREPARE PDU). Otherwise, this information element shall not be included.					
NOTE 5: Mandatory when the new SwMI has modified the value of this information element compared to that of the information element speech service used passed by the old SwMI in the corresponding ISI-CALL RESTORE PREPARE PDU or ISI-PATH CALL RESTORE PREPARE PDU. Otherwise, this information element shall not be included.					

If the new SwMI has received the call restoration message from its new visiting user in time, it will send the TETRA PDU defined in table 48 in the PSS1 CONNECT message (instead of in a PSS1 FACILITY message).

#### 6.3.1.14.2 Cases where no new connection is needed between the old SwMI and the new SwMI

There are two possible cases where no new (ISI) connection is needed between the old SwMI and the new SwMI:

- a) the call has been forward switched and the old SwMI has identified that the new SwMI coincides with the forward switching SwMI;

NOTE 1: In the case of a basic individual call, there cannot be more than one forward switching SwMI (i.e. the called user home SwMI), but there may be more because of interactions with supplementary services which modify the routing of the call (e.g. call forwarding). However it should be noted that in the latter case the ANF-ISIIC PDUs have been specified, for simplicity purpose, in such a manner that they allow only each end SwMI to know the SwMI nearest from it where the call has been forward switched (e.g. for the originating SwMI, the home SwMI of the originally called user). Therefore if the call has been forward switched twice, the originating SwMI will not know the SwMI where the call has been forward switched for the second time. Also, if the call has been forward switched twice, the terminating SwMI will not know the SwMI where the call has been forward switched for the first time. If the call has been forward switched more than twice, neither the originating SwMI nor the terminating SwMI will know any of the forward switching SwMIs between the first and the last one on the path of the call.

- b) the new SwMI coincides with the other end SwMI (i.e. either the originating or the terminating SwMI). The call restoration could then result in the call becoming an intra-TETRA call.

In case a), the old SwMI may send to the new SwMI on the path of the call a PSS1 FACILITY message including a TETRA PDU, the contents and the encoding of which shall be as defined in table 49.

**Table 49: Contents of TETRA PDU in PSS1 FACILITY message sent by the old SwMI to the forward switching/new SwMI in the case of migration during an established call to avoid a trombone connection at call restoration**

Information element	Length	Type	Owner	C/O/M	Remark
PDU type	6	1	CCAp	M	ISI-PATH CALL RESTORE PREPARE
Other end SwMI MNI	24	1	ANF	M	
Call time-out	4	1	CCAp	M	
Simplex/duplex selection	1	1	CCAp	M	
Basic service information	8	1	CCAp	M	
Speech service used	3		CCAp	C	(see note 1)
Security level at calling user air interface	2	1	MM	M	(see notes 2 and 3)
Controlling SwMI	1	1	CCAp	M	
Transmission grant	2	1	CCAp	M	
Transmission request permission	1	1	CCAp	M	
Call priority	4	1	CCAp	M	
Call identifier	14	1	CCAp	M	
Restoring party SSI	24	1	CCAp	M	(see note 4)
Restoring party extension	24	1	CCAp	M	(see note 4)
SS-CLIR invoked for other party	1	1	SS	M	
Other party SSI	24	1	CCAp	M	(see note 5)
Other party extension	24	1	CCAp	M	(see note 5)
Speech services supported	5	2	CCAp	O	(see note 6)
Proprietary		3	-	O	
NOTE 1: Conditional on the binary value of the information sub-element circuit mode type in the information element basic service information being equal to 0 (i.e. the call requested is a speech call).					
NOTE 2: This information element, which defines the security level that the originating SwMI requested at call set-up time the terminating SwMI to match, is sent independently of whether the "old SwMI" is the originating SwMI or the terminating SwMI.					
NOTE 3: In the case of an external incoming call from PSTN/ISDN/PISN, the name of this information element should be understood as "security level used in the other network".					
NOTE 4: The case where the restoring party SSI and the restoring party extension would be those of a gateway is excluded.					
NOTE 5: In the case of an external call, the other party SSI and the other party extension shall be those of the gateway.					
NOTE 6: May be present only when the information element speech service requested is present (see note 1).					

NOTE 2: The ISI-PATH CALL RESTORE PREPARE PDU has been defined (in table 49) as a specific TETRA PDU, even though its contents is the same as that of the ISI-CALL RESTORE PREPARE PDU, defined in table 46, (except of course for the value of its information element PDU type), to allow the SwMI which receives it to identify that it is on the path of the call.

When the forward switching/new SwMI receives the call restoration message from its new visiting user, it will send to the other end SwMI (i.e. either the originating or the terminating SwMI) a PSS1 FACILITY message including the TETRA PDU defined in table 48.

In case b) (i.e. the new SwMI coincides with the originating or the terminating SwMI), the old SwMI may send to the new SwMI a PSS1 FACILITY message including a TETRA PDU, the contents and the encoding of which shall be as defined in table 50.

**Table 50: Contents of TETRA PDU sent by the old SwMI to the other end/new SwMI in a PSS1 FACILITY message to avoid a trombone or a loop connection at call restoration**

Information element	Length	Type	Owner	C/O/M	Remark
PDU Type	6	1	CCAp	M	ISI-END CALL RESTORE PREPARE
Proprietary		3	-	O	

NOTE 3: If the old SwMI did not identify that the new SwMI coincides with the other end SwMI (i.e. case b) above), and thus sent the ISI-CALL RESTORE PREPARE PDU, defined in table 46, instead of the ISI-END CALL RESTORE PREPARE, defined in table 50, the resulting ANF-ISIIC routing would be:

- a trombone connection if the call has been established with no forward switching (either simply between SwMI A and SwMI B, or systematically re-routed) or if it has been forward switched but no other path can be established between the originating and terminating SwMIs than through all the SwMIs through which the call has been forward switched;
- a loop connection if the call has been forward switched and there exists a direct path between the originating and terminating SwMIs.

Finally, the definition of an additional TETRA PDU is needed for addressing the following cases of simultaneous occurrence:

- of case b) for each user engaged in the call; or
- of case b) for one user and of case a) for the other.

More specifically, the case of simultaneous occurrence of case b) for each user can be described as follows in calling the two end SwMIs  $SwMI_{end1}$  and  $SwMI_{end2}$ : case b) occurs for one user engaged in the call, say the one initially registered in  $SwMI_{end1}$ , and, before the ANF-ISIIC call restoration related to the migration of that user (into  $SwMI_{end2}$ ) has been completed, case b) also occurs for the other.

Similarly the case of simultaneous occurrence of case b) for one user and of case a) for the other can be described as follows, still in calling the two end SwMIs  $SwMI_{end1}$  and  $SwMI_{end2}$  and in calling the new SwMI (identified as being of the path of the call) for case a) is called  $SwMI_{fwdsw}$ :

- case b) occurs for one user engaged in the call, say the one initially registered in  $SwMI_{end1}$ , and, before the ANF-ISIIC call restoration related to the migration of that user (into  $SwMI_{end2}$ ) has been completed, case a) occurs for the other, i.e. that other user migrates to  $SwMI_{fwdsw}$  (from  $SwMI_{end2}$ ); or
- case a) occurs first for one user engaged in the call, say the one initially registered in  $SwMI_{end2}$ , and, before the ANF-ISIIC call restoration related to the migration of that user into  $SwMI_{fwdsw}$  has been completed, case b) occurs for the other, i.e. that other user migrates to  $SwMI_{end2}$  (from  $SwMI_{end1}$ ).

In all the cases mentioned above, the new SwMI for the first user for whom case b) occurs (i.e.  $SwMI_{end2}$  in all examples given above) will send to the new SwMI for the other user ( $SwMI_{end1}$  in the example given for the simultaneous occurrence of case b) for each user, or  $SwMI_{fwdsw}$  for the simultaneous occurrence of case b) for one user and of case a) for the other) a PSS1 FACILITY message including a TETRA PDU, the contents and the encoding of which shall be as defined in table 51.

**Table 51: Contents of TETRA PDU sent by the old SwMI to the other end/new SwMI in a PSS1 FACILITY message to avoid a trombone or a loop connection at call restoration**

Information element	Length	Type	Owner	C/O/M	Remark
PDU Type	6	1	CCAp	M	ISI-SIMULTANEOUS MIGRATION
Proprietary		3	-	O	

### 6.3.1.15 TETRA PDUs giving complementary information in PSS1 DISCONNECT messages

Whenever a PSS1 DISCONNECT message is sent to clear an invoked ANF-ISIIC, it will include a TETRA PDU, the contents and the encoding of which shall be as defined in table 52.

NOTE: The clearing of the invoked ANF-ISIIC may be the result of:

- the clearing of the corresponding call by any TETRA application on the path of the call, either during the establishment of the call or after it has been established (e.g. TETRA application for the calling user, the connected user, the originating SwMI or the terminating SwMI, including when the call is rejected by the called user, or by the terminating SwMI, e.g. because it cannot match the air interface security level requested by the originating SwMI - in the ISI-SETUP PDU);
- the clearing of the invoked ANF-ISIIC because the call has become an intra-TETRA call, because of:
  - the invoked ANF-ISIIC has found out through trombone or loop detection that the originating and the terminating SwMIs coincide: the originating SwMI, informed about it through the ISI-REDIRECT PDU, defined in table 29, will then clear the invoked ANF-ISIIC in sending back a PSS1 DISCONNECT message including the TETRA PDU defined in table 52; or
  - call restoration for one of the two users engaged in the (individual) call when that user has migrated into the other end SwMI (e.g. during the call the connected user migrates into the originating SwMI - where the call is restored). This corresponds to what has been identified as case b) in clause 6.3.1.14.2;
- only the clearing of an ISI connection, previously seized by the invoked ANF-ISIIC, which has become unnecessary. The clearing of the invoked ANF-ISIIC is only partial in such cases, which happen because of:
  - re-routeing during the establishment of the call, e.g. if after having received the PSS1 FACILITY with the ISI-REDIRECT PDU, defined in table 29, because the called user has migrated in SwMI C, the originating SwMI decides to re-route the call, it will clear the ISI connection to the called SwMI (previously seized by the ISI-SETUP PDU sent to that SwMI) in sending a PSS1 DISCONNECT message including the TETRA PDU defined in table 52. The same re-routeing operation may take place because of operation of a call forwarding supplementary service; or
  - call restoration for one of the two users engaged in the (individual) call when that user has migrated into a SwMI identified as being on the path of the call (e.g. the connected user was registered in SwMI C, the call has been forward switched through SwMI B, the connected user home SwMI and during the call that user migrates back into SwMI B - where the call is restored). This corresponds to what has been identified as case a) in clause 6.3.1.14.2.

**Table 52: Contents of TETRA PDU sent in the PSS1 DISCONNECT message send by an end SwMI in case of call clearing or call rejection**

Information element	Length	Type	Owner	C/O/M	Remark
PDU Type	6	1	CCAp	M	ISI-DISCONNECT
Disconnect cause	6	1	CCAp	M	
Notification indicator	6	2	SS	O	
Proprietary		3	-	O	

### 6.3.1.16 TETRA PDU giving complementary information in a PSS1 RELEASE message

No TETRA PDU will be included in any PSS1 RELEASE message (sent for an invoked ANF-ISIIC).

NOTE: Clause 10.2.2 of ISO/IEC 11572 [9] defines a call clearing exception condition (where the calling user initiates call clearing before an information channel has been agreed between any two adjacent PISN nodes, e.g. between the originating SwMI and the next node, or between the last but one node and the terminating SwMI) where either a PSS1 DISCONNECT or a PSS1 RELEASE message, but in such a case, there is no TETRA information worth sending.

### 6.3.1.17 TETRA PDUs giving complementary information in a PSS1 RELEASE COMPLETE message

If the called SwMI, or the terminating SwMI when it is different from the called SwMI, rejects the incoming call without having sent any prior PSS1 message, then according to clause 10.2.2 of ISO/IEC 11572 [9], it will send a PSS1 RELEASE COMPLETE message, instead of a DISCONNECT message. Then if the situation is the same as one of those described in clause 6.3.1.17, the corresponding TETRA PDU shall be included in this PSS1 RELEASE COMPLETE message. This concerns the TETRA PDU defined in table 52.

### 6.3.1.18 TETRA PDUs specific for interaction with supplementary service protocol sent to the originating SwMI in a PSS1 FACILITY message

Due to the interaction with some supplementary services, it may happen that the call has been established for the calling user MS/LS and the originating SwMI while it is not established for the called user MS/LS nor for the terminating SwMI (e.g. call diverted to the dispatcher). In such a case, the originating SwMI shall receive a PSS1 FACILITY message including:

- the ISI-THROUGH ALERTING PDU if the call is alerting on the called side;
- the ISI-THROUGH CONNECT PDU if the called user answers the call.

The contents of ISI-THROUGH ALERTING PDU and its encoding shall be as defined in table 53.

**Table 53: Contents of TETRA PDU sent in a PSS1 FACILITY message for informing the originating SwMI that the call is alerting on the called side**

Information element	Length	Type	Owner	C/O/M	Remark
PDU type	6	1	CCAp	M	ISI-THROUGH ALERTING
Call time-out, set-up phase	3	1	CCAp	M	
Hook method selection	1	1	CCAp	M	
Simplex/duplex selection	1	1	CCAp	M	
Call status	4	2	CCAp	M	(see note 1)
Basic service information	8	2	CCAp	O	(see note 2)
Speech service chosen	3	2	CCAp	O	(see note 2)
Notification indicator	6	2	SS	O	
Proprietary		3	-	O	
NOTE 1: If present this information element shall take only the values corresponding to call queued or call waiting (the latter corresponding to SS-CW being invoked by the called user).					
NOTE 2: Mandatory when it is different from requested or from that already sent in another TETRA PDU (i.e. in a PSS1 FACILITY or PROGRESS message). Otherwise, this information element shall not be included.					

NOTE: See notes in clause 6.3.1.5.

The contents of ISI-THROUGH CONNECT PDU and its encoding shall be as defined in table 54.

**Table 54: Contents of TETRA PDU sent in sent in a PSS1 FACILITY message for informing the originating SwMI that the call is answered**

Information element	Length	Type	Owner	C/O/M	Remark
PDU type	6	1	CCAp	M	ISI-THROUGH CONNECT
Terminating SwMI MNI	24	1	ANF	M	
Call diverted to a dispatcher	1	1	ANF	M	
Call time-out	4	1	CCAp	M	
Hook method selection	1	1	CCAp	M	
Simplex/duplex selection	1	1	CCAp	M	
Connected party presentation indicator	2	1	SS	M	
Connected party SSI	24	1	CCAp	M	(see note 1)
Connected party extension	24	1	CCAp	M	(see note 2)
Number of digits in connected external subscriber number	5	1	CCAp	M	(see note 3)
Connected external subscriber number	variable		CCAp	C	(see note 4)
MSISDN present as external subscriber number	1		CCAp	C	(see note 5)
Connected external subscriber number parameters	9		CCAp	C	(see note 5)
Call identified as fleet call	1	1	CCAp	M	
Connected party fleet number SSI	24		CCAp	C	(see note 6)
Call priority	4	2	CCAp	O	(see note 7)
Basic service information	8	2	CCAp	O	(see note 7)
Speech service chosen	3	2	CCAp	O	(see note 7)
Notification indicator	6	2	SS	O	
Proprietary		3	-	O	
NOTE 1: In the case of an external outgoing call, the connected party SSI shall be that of the outgoing gateway SwMI.					
NOTE 2: In the case of an external outgoing call, the connected party extension shall be that of the outgoing gateway SwMI.					
NOTE 3: Shall be equal to 0 when no connected external subscriber number is available or applicable, or to N, N being the number of digits which the connected external subscriber number comprises.					
NOTE 4: The length in bits of this information element shall be equal to 4 x N, N being the number of digits in the external subscriber number (see note 3), i.e. this information element shall be conditional on the value of N.					
NOTE 5: Conditional on the value of the information element number of digits in connected external subscriber number being different from 0.					
NOTE 6: Conditional on the value of the information element call identified as fleet call indicating that the call has been identified as being a fleet call.					
NOTE 7: Mandatory when it is different from requested or from that already sent in another TETRA PDU. Otherwise, this information element shall not be included.					

NOTE: See note 2 in clause 6.3.1.6.

### 6.3.1.19 TETRA PDUs sent towards the Called or Visited SwMI in a PSS1 FACILITY after the PSS1 call has been connected

The ISI-QUEUING PDU can be sent, towards the SwMI of the called party, in response to:

- an ISI-CONNECT PDU; or
- an ISI-RESOURCE-RESPONSE PDU that indicated "resources are reserved";

when an ISI-CONNECT-ACKNOWLEDGE PDU cannot be sent due to queueing in the call. Included in the first ISI-QUEUING PDU is an indication if the signalling for the support of radio traffic channel release is supported. The ISI-QUEUING PDU shall be encoded as presented in table 55.

A SwMI receiving an ISI-QUEUING PDU is eligible to release its allocated traffic channel resources, unless the ISI-QUEUING indicates "not allowed to release radio traffic channel". The "Radio Traffic Channel Release Permission" information element shall be set to "not allowed to release radio traffic channel" the first time the ISI-QUEUING PDU is sent when:

- the Called/Visited SwMI has indicated "resources could not be reserved, delay requested" in the ISI-CONNECT PDU; or
- the Called/Visited SwMI is operating permanent allocation policy.

A Called/Visited SwMI may not release radio traffic channel resources while the possible response from the Originating SwMI is an ISI-CONNECT-ACKNOWLEDGE unless it also clears the call upon reception of the ISI-CONNECT ACKNOWLEDGE if its radio traffic channel resources cannot be acquired immediately. This is the case when the Originating SwMI does not have resources available, it does not support the additional radio traffic channel release signalling, and the Called/Visited SwMI has sent:

- an ISI-CONNECT PDU "resources are reserved"; or
- an ISI-RESOURCE-RESPONSE PDU indicating "resources are reserved".

For all other scenarios the "Radio Traffic Channel Release Permission" information element should be set to "Allowed to release radio traffic channel".

**Table 55: Contents of the TETRA PDU sent in the PSS1 FACILITY message to indicate that the call is queueing for resources**

Information element	Length	Type	Owner	C/O/M	Remark
PDU Type	6	1	CCAp	M	ISI-QUEUING
Radio traffic channel release permission	1	1	CCAp	M	
Radio traffic channel release signalling support	1	2	CCAp	O	(see note)
Notification indicator	6	2	SS	O	
Proprietary		3	-	O	
NOTE:	This information element shall only be present in the PDU when an ISI-QUEUING PDU is sent in response to an ISI-CONNECT PDU, otherwise it shall not be included.				

NOTE: When responding to an ISI-CONNECT PDU containing "Setup temporary allocated resources" and "resources are reserved", the Radio traffic channel release permission information element should be set to "allowed to release radio traffic channel".

Otherwise when responding to an ISI-CONNECT PDU, the Radio traffic channel release permission information element should be set to "not allowed to release radio traffic channel". The reason is to resolve the possible collision with the ISI-RESOURCE-RESPONSE PDU coming in the other direction and indicating "resources are reserved". It ensures that the SwMI of the called party does not release its resources on receipt of the ISI-QUEUING PDU after the ISI-RESOURCE-RESPONSE PDU has been sent.

When responding to an ISI-RESOURCE-RESPONSE PDU containing "resources are reserved" or "resources could not be reserved, delay requested", the Radio traffic channel release permission information element should be set to "allowed to release radio traffic channel".

The calling SwMI on receipt of the ISI-RESOURCE-RESPONSE PDU containing "resources are reserved" will either connect the call or send another ISI-QUEUING PDU (thus allowing the SwMI of the called party to release its radio traffic channel resources) so the SwMI of the called party is not in the "unable to release" state for very long.

If the signalling for the support of radio traffic channel release is supported by a SwMI then the ISI-RESOURCE PDU may be used and it shall be encoded as presented in table 56. It is sent towards the Visited/Called SwMI to ask for the reservation status of traffic channel resources. The PDU is used by the Originating SwMI when its own radio traffic channel resources for the call have been allocated. It requests that, should radio traffic channel resources not be available already, they are made available. The usual response to this PDU is either an ISI-RESOURCE-RESPONSE indicating that "resources could not be reserved, delay requested" followed by another ISI-RESOURCE-RESPONSE when they are available, or a single response indicating that "resources are reserved".

The Originating SwMI may not release its radio traffic channel resources until it receives an ISI-RESOURCE-RESPONSE PDU to the ISI-RESOURCE PDU it has sent (unless it also clears the call).

**Table 56: Contents of the TETRA PDU sent in the PSS1 FACILITY message to request radio traffic channel resource allocation status**

Information element	Length	Type	Owner	C/O/M	Remark
PDU Type	6	1	CCAp	M	ISI-RESOURCE
Notification indicator	6	2	SS	O	
Proprietary		3	-	O	

### 6.3.1.20 TETRA PDUs sent towards the Called or Originating SwMI in a PSS1 FACILITY after the PSS1 call has connected

The ISI-RESOURCE-RESPONSE PDU is sent after an ISI-CONNECT PDU has been sent that indicated "resources could not be reserved, delay requested" and the radio traffic channel resources become available. It is also sent in response to an ISI-RESOURCE PDU. In this case the usual response is either a single ISI-RESOURCE-RESPONSE PDU sent indicating that "resources are reserved", or, if radio traffic channel resources are not immediately available, then an immediate response indicating that "resources could not be reserved, delay requested" followed by another response when the radio traffic channel resources are available. The ISI-RESOURCE-RESPONSE PDU shall be encoded as presented in table 57.

**Table 57: Contents of the TETRA PDU sent in the PSS1 FACILITY message to indicate radio traffic channel resource allocation status**

Information element	Length	Type	Owner	C/O/M	Remark
PDU Type	6	1	CCAp	M	ISI-RESOURCE-RESPONSE
Resource indicator	2	1	CCAp	M	
Notification indicator	6	2	SS	O	
Proprietary		3	-	O	

NOTE: The resource indicator information element values:

- **resources are reserved**, means that the resources are available such that the call to the called party can be connected if required. This value can be sent in an ISI-RESOURCE-RESPONSE PDU sent after an ISI-CONNECT PDU that indicated "resources could not be reserved, delay requested" and the resources become available. It can be sent as a direct response to an ISI-RESOURCE PDU when resources are immediately available or after an ISI-RESOURCE-RESPONSE PDU that indicated "resources could not be reserved, delay requested" and the radio traffic channel resources become available;
- **resources could not be reserved**, means that either previously queued for resources will not be available, or in an immediate response to indicate that resources will never be available even if they were queued for. The call should be disconnected by a SwMI receiving this value. An alternative to sending the PDU with this value is to send a direct ISI-DISCONNECT PDU; and
- **resources could not be reserved, delay requested**, means that although resources are not currently available they are expected to be available soon. The resources are being queued for. When the radio traffic channel resources are available a further ISI-RESOURCE-RESPONSE PDU indicating this is sent.



## 6.3.2 TETRA PDU information element coding

Of the information elements included in the TETRA PDU definitions in clause 6.3.1:

- a number are identical to those defined for air interface messages (same names and definitions). Their definitions have not been reproduced in the present document - see clause 14.8 of EN 300 392-2 [1] for those definitions;
- some have the same names as those defined for air interface messages but with different definitions, i.e. ISI specific. Their definitions are given in clause 6.3.2.1; and
- the others are new. Their definitions are given in clause 6.3.2.2.

NOTE: A given PDU information element already defined for the air interface may or may not take all its possible values when used in ISI TETRA PDUs.

### 6.3.2.1 Specific ISI definition of some information elements already defined for air interface messages

#### 6.3.2.1.1 Basic service information

This information element shall be coded as defined in table 90 of EN 300 392-2 [1]. However when the value of its information sub-element circuit mode type corresponds to speech, the value of its other information sub-element speech service shall be ignored (see clause 6.3.2.2.44).

#### 6.3.2.1.2 Call status

The call status information element shall inform the other end SwMI about the status of the call as defined in table 58.

**Table 58: Call status information element contents**

Information element	Length	Value	Remark
Call status	4	0000 <sub>2</sub>	Call is proceeding (see note)
		0001 <sub>2</sub>	Call is queued (see note)
		0010 <sub>2</sub>	Requested subscriber is paged (see note)
		0011 <sub>2</sub>	Call continue (see note)
		0100 <sub>2</sub>	Hang time expired (see note)
		0101 <sub>2</sub>	Reserved (see note)
		0110 <sub>2</sub>	Reserved (see note)
		0111 <sub>2</sub>	Reserved (see note)
		1000 <sub>2</sub>	Call waiting
		1001 <sub>2</sub>	Call put on hold
		1010 <sub>2</sub>	Call on hold retrieved
		> 1010 <sub>2</sub>	Reserved
NOTE: All values 0XXX <sub>2</sub> shall be as defined in table 101 of EN 300 392-2 [1] for the same values (XXX <sub>2</sub> ). The definitions given in the present table for those values are a copy of that table, to be considered for information only.			

#### 6.3.2.1.3 Call time-out, set-up phase

First, as opposed to its definition for the air interface protocol, in clause 14.8.17 of EN 300 392-2 [1], this information element shall not set the corresponding timer at the air interface at the other end SwMI (T301 in the case of the terminating SwMI, and T302 in that of the originating SwMI). It simply informs the other end SwMI about the call time-out in the set-up phase decided by the SwMI which is sending this information.

NOTE 1: The other end SwMI may then decide or not to update the relevant timer in the MS/LS involved in the call attempt.

NOTE 2: While the value of the information element call time-out, set-up phase, sent by the terminating SwMI can be used directly by the originating SwMI to "start" (the meaning of "start" being as defined in clause 14.5 of EN 300 392-2 [1]) timer T302 with this value, this is not the case for the terminating SwMI with timer T301. How the terminating SwMI handles this information element when it receives it is an implementation matter.

Regarding the coding of this information element, it shall be as defined in table 105 of EN 300 392-2 [1], except that no predefined value shall be used (i.e. the value 000<sub>2</sub> shall be reserved). The resulting coding is defined in table 59.

**Table 59: Call time-out, set-up phase information element contents**

Information element	Length	Value	Remark
Call time-out, set-up phase	3	000 <sub>2</sub>	Reserved
		001 <sub>2</sub>	1 s
		010 <sub>2</sub>	2 s
		011 <sub>2</sub>	5 s
		100 <sub>2</sub>	10 s
		101 <sub>2</sub>	20 s
		110 <sub>2</sub>	30 s
		111 <sub>2</sub>	60 s

#### 6.3.2.1.4 Disconnect cause information element

The purpose of the information element disconnect cause is to inform the SwMI to which the PSS1 clearing message (DISCONNECT or possibly RELEASE COMPLETE) carrying this information element is sent, of the reason for that clearing. This information element shall be coded as defined in table 60.

**Table 60: Disconnect cause information element contents**

Information element	Length	Value	Remark
Disconnect cause	6		<b>Air interface specific disconnect causes</b>
		000000 <sub>2</sub>	Refer to EN 300 392-2 [1], clause 14.8 (see note)
		etc.	etc.
		011111 <sub>2</sub>	Refer to EN 300 392-2 [1], clause 14.8 (see note)
			<b>ISI specific disconnect causes</b>
		100000 <sub>2</sub>	Call rejected by the terminating/called SwMI: cause unspecified
		100001 <sub>2</sub>	Call rejected by the terminating/called SwMI because the security level at calling user air interface cannot be matched
		100010 <sub>2</sub>	Call re-routed
		100011 <sub>2</sub>	No possible routing of the call
		100100 <sub>2</sub>	Call restored
		100101 <sub>2</sub>	ANF-ISIIC call restoration procedure not supported in new SwMI
		100110 <sub>2</sub>	Call rejected by the originating SwMI: cause unspecified
		100111 <sub>2</sub>	Reserved for ANF-ISIIC
		etc.	etc.
		101111 <sub>2</sub>	Reserved for ANF-ISIIC
		110000 <sub>2</sub>	Reserved for ANF-ISIGC, see EN 300 392-3-3 [3], clause 6.3.2.1.3
		etc.	etc.
		111110 <sub>2</sub>	Reserved for ANF-ISIGC, see EN 300 392-3-3 [3], clause 6.3.2.1.3
		111111 <sub>2</sub>	Reserved
NOTE: All values 0XXXXX <sub>2</sub> shall be as defined in table 106 of EN 300 392-2 [1] for the same values (XXXXX <sub>2</sub> ).			

NOTE: 6 bits are used for encoding the disconnect cause information element. This is one more bit than what is used at the air interface for the disconnect cause information element. The binary values 000000<sub>2</sub> to 011111<sub>2</sub> have remained unchanged while the values from 100000<sub>2</sub> to 111110<sub>2</sub> will be used as ISI specific definitions.

### 6.3.2.1.5 PDU type

The purpose of the information element PDU type is to clearly identify the type of TETRA PDU sent over the ISI in a PSS1 message. This information element shall be coded as defined in table 61.

NOTE: A PDU type value has been defined for every possible TETRA PDU even for those which are the only one possibly sent in a given PSS1 (basic call) message.

**Table 61: PDU type information element contents**

Information element	Length	Value	Remark
PDU Type	6	000000 <sub>2</sub>	ISI-ALERTING (see table 31)
		000001 <sub>2</sub>	ISI-CALL PROCEEDING (see table 33)
		000010 <sub>2</sub>	ISI-CALL RESTORE PREPARE (see table 46)
		000011 <sub>2</sub>	ISI-CALL RESTORE PREPARED (see table 47)
		000100 <sub>2</sub>	ISI-CALL-RESTORATION (see table 48)
		000101 <sub>2</sub>	ISI-CONNECT (see table 32)
		000110 <sub>2</sub>	ISI-CONNECT ACKNOWLEDGE (see table 35)
		000111 <sub>2</sub>	ISI-DISCONNECT (see table 52)
		001000 <sub>2</sub>	ISI-END CALL RESTORE PREPARE (see table 50)
		001001 <sub>2</sub>	ISI-FORWARD SWITCH (see table 30)
		001010 <sub>2</sub>	ISI-INFO DEMAND (see table 41)
		001011 <sub>2</sub>	ISI-INFO REPLY (see table 42)
		001100 <sub>2</sub>	ISI-PATH CALL RESTORE PREPARE (see table 49)
		001101 <sub>2</sub>	ISI-PROGRESS (see table 28)
		001110 <sub>2</sub>	ISI-REDIRECT (see table 29)
		001111 <sub>2</sub>	Reserved
		010000 <sub>2</sub>	ISI-SETUP (see table 27)
		010001 <sub>2</sub>	ISI-SETUP PROLONGATION (see table 34)
		010010 <sub>2</sub>	ISI-SIMULTANEOUS MIGRATION (see table 51)
		010011 <sub>2</sub>	ISI-THROUGH ALERTING (see table 53)
		010100 <sub>2</sub>	ISI-THROUGH CONNECT (see table 54)
		010101 <sub>2</sub>	ISI-TX CEASED IN ORIGINATING SwMI (see table 38)
		010110 <sub>2</sub>	ISI-TX CONTINUE IN ORIGINATING SwMI (see table 39)
		010111 <sub>2</sub>	ISI-TX DEMAND (see table 43)
		011000 <sub>2</sub>	ISI-TX GRANTED (see table 36)
		011001 <sub>2</sub>	ISI-TX INTERRUPT (see table 37)
		011010 <sub>2</sub>	ISI-TX WAIT (see table 40)
		011011 <sub>2</sub>	ISI-QUEUING (see table 55)
		011100 <sub>2</sub>	ISI-RESOURCE (see table 56)
		011101 <sub>2</sub>	ISI-TX CEASED IN TERMINATING SwMI (see table 44)
		011110 <sub>2</sub>	ISI-TX CONTINUE IN TERMINATING SwMI (see table 45)
		011111 <sub>2</sub>	ISI-RESOURCE-RESPONSE (see table 57)
>011111 <sub>2</sub>	Reserved		

A SwMI receiving an unknown ISI PDU will disconnect the ISI individual call with an ISI-DISCONNECT PDU.

## 6.3.2.2 New information elements used at the ISI

### 6.3.2.2.1 Call diverted to a dispatcher

This information element shall indicate whether or not the call has been diverted to a dispatcher (as a result of the invocation of SS-CAD). It shall be coded as defined in table 62.

**Table 62: Call diverted to a dispatcher information element content**

Information element	Length	Value	Remark
Call diverted to a dispatcher	1	0	Call not diverted to a dispatcher
		1	Call diverted to a dispatcher

### 6.3.2.2.2 Call has been forward switched

This information element shall indicate whether or not the call has already been routed by forward switching (e.g. the called user home SwMI is the called SwMI and the path of the call transits through that SwMI). It shall be coded as defined in table 63.

**Table 63: Call has been forward switched information element content**

Information element	Length	Value	Remark
Call has been forward switched	1	0	The call has not been forward switched previously
		1	The call has been forward switched

### 6.3.2.2.3 Call identified as fleet call

This information element shall indicate whether or not the call has been identified as a fleet call (such identification being made by the called user home SwMI). It shall be coded as defined in table 64. Refer to TR 102 300-5 [i.10] clause 5.4.3 for fleet specific short numbers.

**Table 64: Call identified as fleet call information element contents**

Information element	Length	Value	Remark
Call identified as fleet call	1	0	The call has not been identified as a fleet call
		1	The call has been identified as a fleet call

### 6.3.2.2.4 Called/forwarded-to external subscriber number

This information element shall be coded as defined in clause 14.8.20 of EN 300 392-2 [1] for the air interface information element external subscriber number, except that its length in bits shall be equal to  $4 \times N$ , N being the value of the associated information element: number of digits in called/forwarded-to external subscriber number.

### 6.3.2.2.5 Called/forwarded-to party extension

This information element shall be coded as defined in table 95 of EN 300 392-2 [1] for the air interface information element called party extension.

### 6.3.2.2.6 Called/forwarded-to party SSI

This information element shall be coded as defined in table 96 of EN 300 392-2 [1] for the air interface information element called party SSI.

### 6.3.2.2.7 Called/forwarded-to party fleet number SSI

This information element shall be coded as defined in table 96 of EN 300 392-2 [1] for the air interface information element called party SSI.

### 6.3.2.2.8 Called/forwarded-to user having migrated

This information element shall indicate whether or not the called or the forwarded-to user, whichever applies in the case considered, has migrated. It shall be coded as defined in table 65.

**Table 65: Called/forwarded-to user having migrated information element content**

Information element	Length	Value	Remark
Called/forwarded-to user having migrated	1	0	The called/forwarded-to user has not migrated
		1	The called/forwarded-to user has migrated

### 6.3.2.2.9 Calling external subscriber number

This information element shall be coded as defined in clause 14.8.20 of EN 300 392-2 [1] for the air interface information element external subscriber number, except that its length in bits shall be equal to  $4 \times N$ , N being the value of the associated information element: number of digits in calling external subscriber number.

### 6.3.2.2.10 Calling external subscriber number parameters

The meaning and the coding of this information element shall be as defined in table 21 of EN 300 392-9 [6] for the supplementary information element external subscriber number parameters.

### 6.3.2.2.11 Calling party fleet number SSI

This information element shall be coded as defined in table 96 of EN 300 392-2 [1] for the air interface information element called party SSI.

### 6.3.2.2.12 Calling party presentation indicator

This information element shall indicate whether or not the calling party identity can or may be presented to the called party through the supplementary services Calling Line Identification Presentation (SS-CLIP) or Talking Party Identification (SS-TPI). It shall be coded as defined in table 27 of ISO/IEC 11572 [9] for the presentation indicator.

The corresponding definition of the calling party presentation indicator information element is reproduced in table 66. In case of discrepancy, table 27 of ISO/IEC 11572 [9] applies.

**Table 66: Calling party presentation indicator information element contents**

Information element	Length	Value	Remark
Calling party presentation indicator	2	00 <sub>2</sub>	Presentation allowed
		01 <sub>2</sub>	Presentation restricted
		10 <sub>2</sub>	Number not available due to interworking
		11 <sub>2</sub>	Reserved

### 6.3.2.2.13 Cause for PDU addressed to originating SwMI

This information element shall indicate the reason why the ISI-REDIRECT PDU is specifically addressed to the originating SwMI. Those reasons are presented in table 67, together with the definition of the corresponding coding.

**Table 67: Cause for PDU addressed to originating SwMI information element contents**

Information element	Length	Value	Remark
Cause for PDU addressed to originating SwMI	3	000 <sub>2</sub>	No SS-CF invoked, called user migration in originating SwMI
		001 <sub>2</sub>	Called user barred, having migrated in originating SwMI, SS-CFU invoked
		010 <sub>2</sub>	Called user barred, having migrated in originating SwMI, SS-CFNR <sub>C</sub> invoked
		011 <sub>2</sub>	Reserved
		100 <sub>2</sub>	Reserved
		101 <sub>2</sub>	Reserved
		110 <sub>2</sub>	Reserved
		111 <sub>2</sub>	SS-CF invoked, SS-CF served user not barred, forwarded-to user not barred and having migrated in originating SwMI

### 6.3.2.2.14 Connected external subscriber number

This information element shall be coded as defined in clause 14.8.20 of EN 300 392-2 [1] for the air interface information element external subscriber number, except that its length in bits shall be equal to 4 x N, N being the value of the associated information element: number of digits in connected external subscriber number.

### 6.3.2.2.15 Connected external subscriber number parameters

The meaning and the coding of this information element shall be as defined in table 21 of EN 300 392-9 [6] for the supplementary information element external subscriber number parameters.

### 6.3.2.2.16 Connected party presentation indicator

This information element shall indicate whether or not the connected party identity can or may be presented to the calling party through the Supplementary Services Connected Line Identification Presentation (SS-COLP) or Talking Party Identification (SS-TPI). It shall be coded as defined in table 27 of ISO/IEC 11572 [9] for the presentation indicator.

The corresponding definition of the connected party presentation indicator information element is reproduced in table 68. In case of discrepancy, table 27 of ISO/IEC 11572 [9] applies.

**Table 68: Connected party presentation indicator information element contents**

Information element	Length	Value	Remark
Connected party presentation indicator	2	00 <sub>2</sub>	Presentation allowed
		01 <sub>2</sub>	Presentation restricted
		10 <sub>2</sub>	Number not available due to interworking
		11 <sub>2</sub>	Reserved

### 6.3.2.2.17 Connected party extension

The coding of this information element shall be the same as in table 95 of EN 300 392-2 [1].

### 6.3.2.2.18 Connected party SSI

This information element shall be coded as defined in table 96 of EN 300 392-2 [1] for the air interface information element called party SSI.

### 6.3.2.2.19 Connected party fleet number SSI

This information element shall be coded as defined in table 96 of EN 300 392-2 [1] for the air interface information element called party SSI.

### 6.3.2.2.20 Controlling SwMI

This information element shall indicate to a new SwMI involved in the call (e.g. in case of call restoration) whether or not it is going to be the controlling SwMI for that call (which shall be the case when the user registered in this new SwMI was the calling user). It shall be coded as defined in table 69.

**Table 69: Controlling SwMI information element content**

Information element	Length	Value	Remark
Controlling SwMI	1	0	The other end SwMI is the controlling SwMI
		1	The new SwMI shall be the controlling SwMI

### 6.3.2.2.21 Incoming call barring status

This information element shall be used to inform the ANF-ISIIC entity in the terminating SwMI about the result of SS-BIC barring or SS-CAD authorization of the incoming call. When barred by SS-BIC the incoming call shall then be rejected by the ANF-ISIIC entity in the terminating SwMI unless the call is an intra-TETRA call and a local SS-BIC applies. This information element shall be coded as defined in table 70.

**Table 70: Incoming call barring status information element contents**

Information element	Length	Value	Remark
Incoming call barring status	2	00 <sub>2</sub>	Neither SS-BIC nor SS-CAD activated
		01 <sub>2</sub>	Call authorized by SS-CAD
		10 <sub>2</sub>	Call barred by SS-BIC
		11 <sub>2</sub>	Call authorized by SS-BIC

### 6.3.2.2.22 Forwarded-to external subscriber number

This information element shall be coded as defined in clause 14.8.20 of EN 300 392-2 [1] for the air interface information element external subscriber number, except that its length in bits shall be equal to  $4 \times N$ ,  $N$  being the value of the associated information element: number of digits in forwarded-to external subscriber number.

### 6.3.2.2.23 Forwarded-to user extension

This information element shall be coded as defined in table 95 of EN 300 392-2 [1] for the air interface information element called party extension.

### 6.3.2.2.24 Forwarded-to user SSI

This information element shall be coded as defined in table 96 of EN 300 392-2 [1] for the air interface information element called party SSI.

### 6.3.2.2.25 Last Forwarding SwMI MNI

This information element shall be coded as defined in table 95 of EN 300 392-2 [1] for the air interface information element called party extension.

### 6.3.2.2.26 Modify accepted

This information element shall indicate the modification in the simplex/duplex selection or/and the basic service decided by the controlling SwMI when different from that requested. It shall be coded as defined in table 112 of EN 300 392-2 [1] for the air interface information element modify.

### 6.3.2.2.27 Modify request

This information element shall indicate the modification in the simplex/duplex selection or/and the basic service requested to the controlling SwMI. It shall be coded as defined in table 112 of EN 300 392-2 [1] for the air interface information element modify.

### 6.3.2.2.28 MSISDN present as external subscriber number

This information element shall indicate whether or not the related information element external subscriber number corresponds to an MSISDN. It shall be coded as defined in table 71.

**Table 71: MSISDN present as external subscriber number information element content**

Information element	Length	Value	Remark
MSISDN present as external subscriber number	1	0	The related information element external subscriber number does not correspond to an MSISDN
		1	The related information element external subscriber number corresponds to an MSISDN

### 6.3.2.2.29 New SwMI MNI

This information element shall be coded as defined in table 95 of EN 300 392-2 [1] for the air interface information element called party extension.

### 6.3.2.2.30 Number of digits in called/forwarded-to external subscriber number

This information element shall be coded as defined in table 72.

**Table 72: Number of digits in called/forwarded-to external subscriber number length information element content**

Information element	Length	Value	Remark
Number of digits in called/forwarded-to external subscriber number	5	00000 <sub>2</sub>	(see note 1)
		> 00000 <sub>2</sub>	(see note 2)
NOTE 1: The presence of the information element called/forwarded-to external subscriber number in TETRA PDUs after this information element shall be conditional on the value of this information element being different from 0.			
NOTE 2: The number of digits in the related information element called/forwarded-to external subscriber number shall be equal to N, the decimal number corresponding to the binary value XXXXX <sub>2</sub> .			

NOTE: Actually, the number of digits in called/forwarded-to external subscriber number is not an information element per se, but it is needed according to the PDU encoding rules defined in annex E of EN 300 392-2 [1], for encoding the related information element called/forwarded-to external subscriber number (the length of which is variable) as "a type 1 element".

### 6.3.2.2.31 Number of digits in calling external subscriber number

This information element shall be coded as defined in clause 6.3.2.2.30 for the information element number of digits in called/forwarded-to external subscriber number. The related information element shall then be the information element calling external subscriber number instead of the information element called/forwarded-to external subscriber number.

### 6.3.2.2.32 Number of digits in connected external subscriber number

This information element shall be coded as defined in clause 6.3.2.2.30 for the information element number of digits in called/forwarded-to external subscriber number. The related information element shall then be the information element connected external subscriber number instead of the information element called/forwarded-to external subscriber number.



### 6.3.2.2.33 Number of digits in forwarded-to external subscriber number

This information element shall be coded as defined in clause 6.3.2.2.30 for the information element number of digits in called/forwarded-to external subscriber number. The related information element shall then be the information element forwarded-to external subscriber number instead of the information element called/forwarded-to external subscriber number.

### 6.3.2.2.34 Number of digits in visited/forwarded-to SwMI PISN number

This information element shall be coded as defined in clause 6.3.2.2.30 for the information element number of digits in called/forwarded-to external subscriber number. The related information element shall then be the information element visited/forwarded-to SwMI PISN number instead of the information element called/forwarded-to external subscriber number.

### 6.3.2.2.35 Originating SwMI MNI

This information element shall be coded as defined in table 95 of EN 300 392-2 [1] for the air interface information element called party extension.

### 6.3.2.2.36 Other end SwMI MNI

This information element shall be coded as defined in table 95 of EN 300 392-2 [1] for the air interface information element called party extension.

### 6.3.2.2.37 Override SS-CAD invocation

This information element, used only in the ISI-SETUP PDU, shall indicate whether or not that call may bypass the invocation of SS-CAD. It shall be coded as defined in table 73.

**Table 73: Override SS-CAD invocation information element content**

Information element	Length	Value	Remark
Override SS-CAD invocation	1	0	No overriding of SS-CAD invocation
		1	Overriding of SS-CAD invocation
NOTE 1: If a SwMI does not support SS-CAD, or has not applied SS-CAD, then "No overriding of SS-CAD invocation" is used.			
NOTE 2: If SS-CAD has already been performed in the calling SwMI then "Overriding of SS-CAD invocation" is used.			

### 6.3.2.2.38 PDU addressed to originating SwMI

This information element shall indicate whether or not the PDU in which this information element is present is addressed to the originating SwMI. It shall be coded as defined in table 74.

**Table 74: PDU addressed to originating SwMI information element content**

Information element	Length	Value	Remark
PDU addressed to originating SwMI	1	0	The PDU is not addressed to the originating SwMI
		1	The PDU is addressed to the originating SwMI

### 6.3.2.2.39 Possible ISI trombone or loop connection detected

This information element shall indicate whether or not the SwMI sending the PDU in which this information element is present has identified that if it routed the call by forward switching, it would result in an ISI trombone or loop connection. This information element shall be coded as defined in table 75.

**Table 75: Possible ISI trombone or loop connection detected information element content**

Information element	Length	Value	Remark
Possible ISI trombone or loop connection detected	1	0	No possible ISI trombone or loop connection resulting from forward switching detected
		1	Possible ISI trombone or loop connection resulting from forward switching detected

#### 6.3.2.2.40 Restoring party extension

This information element shall be coded as defined in table 95 of EN 300 392-2 [1] for the air interface information element called party extension.

#### 6.3.2.2.41 Restoring party SSI

This information element shall be coded as defined in table 96 of EN 300 392-2 [1] for the air interface information element called party SSI.

#### 6.3.2.2.41a Radio traffic channel release permission

The Radio traffic channel release permission information element shall be encoded as presented in table 76.

**Table 76: Radio traffic channel release permission information element content**

Information element	Length	Value	Remark
Radio traffic channel release permission	1	0	Allowed to release radio traffic channel
		1	Not allowed to release radio traffic channel
<p>NOTE: Used in an ISI-QUEUING PDU. When responding to an ISI-CONNECT PDU containing "Setup temporary allocated resources" and "resources are reserved", it is set to "allowed to release radio traffic channel" if ISI-QUEUING PDU contains "Radio traffic channel release signalling supported". Otherwise, when responding to an ISI-CONNECT PDU it is set to "not allowed to release radio traffic channel". The reason is to resolve the possible collision with the ISI-RESOURCE-RESPONSE PDU coming in the other direction and indicating "resources are reserved". It ensures that the SwMI of the called party does not release its resources on receipt of the ISI-QUEUING PDU after the ISI-RESOURCE-RESPONSE PDU has been sent.</p> <p>When responding to an ISI-RESOURCE-RESPONSE PDU containing "resources are reserved", or "resources could not be reserved, delay requested", it is set to "allowed to release radio traffic channel". The calling SwMI on receipt of the ISI-RESOURCE-RESPONSE PDU will either connect the call or send another ISI-QUEUING PDU (thus allowing the SwMI of the called party to release its radio traffic channel resources) so the SwMI of the called party is not in the "unable to release" state for very long.</p>			

## 6.3.2.2.41b Radio traffic channel release signalling supported

The Radio traffic channel release signalling supported information element shall be encoded as presented in table 77.

**Table 77: Radio traffic channel release signalling supported information element content**

Information element	Length	Value	Remark
Radio traffic channel release signalling supported	1	0	Radio traffic channel release signalling supported
		1	Radio traffic channel release signalling not supported
<p>NOTE: Used in an ISI-QUEUING PDU. It indicates if the SwMI is able to support the use of the ISI-RESOURCE PDU. The actions of the receiving SwMI are system dependent. For example if the receiving SwMI would ideally like the sending SwMI to support the signalling for the release of resources, but it does not then it could:</p> <ul style="list-style-type: none"> <li>• change to using "setup permanently allocated resources";</li> <li>• clear the call (not recommended);</li> <li>• clear the call if it need to release radio traffic channel resources;</li> <li>• allow radio traffic channel resources to be released and try to obtain them again on the receipt of an ISI-CONNECT-ACKNOWLEDGE. The call could be cleared if the resources were not immediately available;</li> <li>• some other strategy.</li> </ul> <p>The Originating SwMI sets the value of this field, in the ISI-QUEUING, to "radio traffic channel release signalling not supported" if the called/visited SwMI is adopting a policy of "setup permanently allocated resources" as indicated to it in the ISI-CONNECT. This is the case even if it can support such signalling.</p>			

## 6.3.2.2.41c Resource indicator

The resource indicator information element shall be encoded as presented in table 78.

**Table 78: Resource indicator information element content**

Information element	Length	Value	Remark
Resource indicator	2	00 <sub>2</sub>	Resources are reserved
		01 <sub>2</sub>	Resources could not be reserved
		10 <sub>2</sub>	Resources could not be reserved, delay requested
		11 <sub>2</sub>	Reserved

## 6.3.2.2.42 Routeing method choice

This information element shall be coded as defined in table 79.

**Table 79: Routeing method choice information element contents**

Information element	Length	Value	Remark
Routeing method choice	3	000 <sub>2</sub>	Re-routeing not supported
		001 <sub>2</sub>	Re-routeing supported, forward switching preferred
		010 <sub>2</sub>	Re-routeing supported, the called SwMI may choose between forward switching and re-routeing
		011 <sub>2</sub>	Rerouting supported, possible choice between forward switching and rerouting to be made by the SwMI sending this SETUP PDU
		> 011 <sub>2</sub>	Reserved

## 6.3.2.2.43 Routeing method response

This information element shall be coded as defined in table 80.

**Table 80: Routeing method response information element contents**

Information element	Length	Value	Remark
Routeing method response	3	000 <sub>2</sub>	Forward switching not supported
		001 <sub>2</sub>	Forward switching supported
		010 <sub>2</sub>	Select re-routeing
		011 <sub>2</sub>	Congestion in the SwMI sending this ISI-REDIRECT PDU
		100 <sub>2</sub>	No N x 8 kbit/s link with next SwMI (see note)
		> 100 <sub>2</sub>	Reserved
NOTE: Corresponds to the case where the ANF-ISIIC information transfer rate is equal to N x 8 kbit/s and where the call cannot be forwarded switched because that information transfer rate is not be available on the second leg of the call.			

## 6.3.2.2.44 Security level at calling user air interface

The Security level at calling user air interface information element shall be encoded as presented in table 81.

NOTE: The TETRA air interface security level is defined in EN 300 392-7 [i.1], clause 6.2.

**Table 81: Security level at calling user air interface information element contents**

Information element	Length	Value	Remark
Security level at calling user air interface	2	00 <sub>2</sub>	No air interface encryption required
		01 <sub>2</sub>	Air interface encryption required 1
		10 <sub>2</sub>	Air interface encryption required 2
		11 <sub>2</sub>	Reserved

## 6.3.2.2.44a Setup resource allocation

The Setup resource allocation information element shall be encoded as presented in table 82.

**Table 82: Setup resource allocation information element content**

Information element	Length	Value	Remark
Setup resource allocation	1	0	Setup permanently allocated resources
		1	Setup temporary allocated resources

## 6.3.2.2.45 Speech service requested/chosen/used

This information element shall be coded as defined in table 83.

**Table 83: Speech service requested/chosen/used information element contents**

Information element	Length	Value	Remark
Speech service requested/chosen/used	3	000 <sub>2</sub>	CODEC defined in EN 300 395-2 [i.4]
		> 000 <sub>2</sub>	Reserved

### 6.3.2.2.46 Speech services supported

This information element is a bit-map field indicating which CODEC are supported. The meaning of each bit setting in this information element shall be as defined in table 84.

**Table 84: Speech services supported information element contents**

Information element	Length	Value	Remark
Speech services supported	8	00000000 <sub>2</sub>	Reserved
		00000001 <sub>2</sub>	CODEC defined in EN 300 395-2 [i.4] supported
		> 00000001 <sub>2</sub>	Reserved

### 6.3.2.2.47 SS-CF invocation counter

The meaning and the coding of this information element shall be as defined in clause 5.2.2.21 of EN 300 392-12-4 [8].

### 6.3.2.2.48 SS-CF invoked

This information element shall indicate whether or not SS-CF invoked has been invoked the SwMI sending the PDU in which this information element is present. It shall be coded as defined in table 85.

**Table 85: SS-CF invoked information element content**

Information element	Length	Value	Remark
SS-CF invoked	1	0	SS-CF not invoked in SwMI sending the PDU
		1	SS-CF not invoked in SwMI sending the PDU

### 6.3.2.2.49 SS-CLIR invoked for other party

This information element shall be coded as defined in table 86.

**Table 86: SS-CLIR invoked for other party information element contents**

Information element	Length	Value	Remark
SS-CLIR invoked for other party	1	0	SS-CLIR not invoked for the other party
		1	SS-CLIR invoked for the other party

### 6.3.2.2.50 Terminating SwMI MNI

This information element shall be coded as defined in table 95 of EN 300 392-2 [1] for the air interface information element called party extension.

### 6.3.2.2.51 Visited/forwarded-to SwMI MNI

This information element shall be coded as defined in table 95 of EN 300 392-2 [1] for the air interface information element called party extension.

### 6.3.2.2.52 Visited/forwarded-to SwMI PISN number

This information element shall be coded as defined in clause 14.8.20 of EN 300 392-2 [1] for the air interface information element external subscriber number, except that its length in bits shall be equal to  $4 \times N$ , N being the value of the associated information element: number of digits in visited/forwarded-to SwMI PISN number.

### 6.3.3 PSS1 facility information element

The ROSE operation `tetraIsiMessage` referred to in clause 6.3.1 shall be coded in PSS1 facility information elements in accordance with ISO/IEC 11582 [11]. Each such facility information elements shall always include a Network Facility Extension (NFE).

The `destinationEntity` and `sourceEntity` data elements of the Network Facility Extension (NFE) shall contain the value `endPINX` except in two following specific cases where the call is an inter-TETRA call established with at least one forward switching operation:

- one of the two users engaged in this call migrates and registers in a SwMI which the old SwMI for that migrating user identifies as being on the path of the call (i.e. the call has been forward switched in that new SwMI); the old SwMI will then want to address the ISI-PATH RESTORE PREPARE PDU, defined in table 49, to that new SwMI;
- SS-CF has been invoked and the ISI-REDIRECT PDU, defined in table 29, has to be sent to the preceding SwMI (i.e. the last forwarding SwMI on the path of the call), and not to the originating SwMI.

In each of the above cases, the `destinationEntity` data element of the Network Facility Extension (NFE) of the PSS1 facility information element (in the PSS1 FACILITY message) conveying the ROSE operation `tetraIsiMessage` including the ISI-PATH RESTORE PREPARE PDU or the ISI-REDIRECT PDU shall contain the value `anyTypeOfPINX` with a `destinationEntityAddress` containing a PISN number corresponding to the new SwMI or to the last forward switching on the path of the call. That PISN number shall be either:

- that delivered by ANF-ISIMM (e.g. the SwMI on the path of the call is the home SwMI of the connected user and the PISN number to use that user - while registered in that SwMI- has been delivered by ANF-ISIMM - such delivery being an ANF-ISIMM option); or
- that determined by the SwMI sending the above TETRA PDU as corresponding to the destination SwMI in its routing table.

The `sourceEntity` and `destinationEntity` data elements of the argument of the ROSE operation `tetraIsiMessage` shall contain the value ANF-ISIIC.

Whenever the ANF-ISIIC Invoke APDU of the ROSE operation `tetraIsiMessage` is included in a PSS1 SETUP message, the Interpretation APDU shall be included with the value "clearCallIfAnyInvokePduNotRecognized".

NOTE: According to clause 8.6 of EN 300 392-3-1 [2], if the called SwMI or the terminating SwMI do not support inter-TETRA individual calls, i.e. they do not have an ANF-ISIIC entity, when it receives a PSS1 SETUP message addressed to this entity such SwMI:

- will have its ROSE entity rejecting the ROSE Invoke APDU received; and
- will clear the PSS1 call attempt due to the specific value of the Interpretation APDU received together with the ROSE Invoke APDU.

The same will hold if the new SwMI in the call restoration procedure (see clause 6.5.2.3) does not support inter-TETRA individual calls.

No Interpretation APDU shall be included together with any of the ANF-ISIIC Invoke APDUs of the ROSE operation `tetraIsiMessage` included in other PSS1 messages than SETUP messages.

In accordance with EN 300 392-3-1 [2] clause 8.4, the ISI entity concerned in the destination SwMI will trigger the sending of a `returnError` APDU when one or more of the error causes listed in this clause has occurred in the reception of an Invoke APDU.

Among those error causes, the cause corresponding to `requestNotSupported` (see clause 8.4 of EN 300 392-3-1 [2]) may only apply when a specific ANF-ISIIC request is not supported. The cases where this may happen are:

- if the called user has migrated, if its home SwMI is the called SwMI and if the originating and the called SwMIs cannot agree on the routing method to be used: forward switching versus re-routing (see table 67);
- if one of the two parties migrates during an individual call and registers in a new SwMI which supports individual calls but not call restoration (see clause 6.5.2.3).

When the ROSE entity in the source SwMI receives this returnError APDU or a reject APDU, it shall pass it to the call control application in this SwMI. The decision taken by this call control application when the destination SwMI has not already cleared the call is an implementation matter (e.g. clearing the call or if the Invoke APDU was not essential, continue the call).

## 6.4 ANF-ISIIC state definitions

NOTE: These states correspond to both the PINX protocol control states for circuit-mode call, defined in clause 7.1 of ISO/IEC 11572 [9], and the SwMI protocol control states for individual (circuit-mode) call. The SwMI protocol states have not been explicitly standardized in EN 300 392-2 [1].

## 6.5 ANF-ISIIC signalling procedures

The signalling procedures below specify the conditions under which the SwMI ANF-ISIIC entities send or receive:

- the TETRA ISI PDUs defined in clause 6.3.1; and
- PISN basic call primitives together with some of these TETRA PDUs.

The specific parameters of some of those primitives have been defined in clause 6.2.

To simplify the text below, only the results of those PISN basic call primitives have been specified, e.g. sending of a PSS1 SETUP or CONNECT message.

NOTE: From a formal point of view the SwMI PSS1 protocol control entities are not part of the ANF-ISIIC entities.

### 6.5.1 Call establishment

#### 6.5.1.1 Call request, information channel selection, PISN called number sending and call proceeding

Call establishment shall be initiated by a primitive sent by the CC entity to the ANF-ISIIC entity in the originating SwMI. This ANF-ISIIC entity shall then send the PSS1 SETUP message defined in clause 6.2.1 including the ISI-SETUP PDU, defined in table 27.

The procedures defined in ISO/IEC 11572 [9] for information channel selection, called number sending, call proceeding shall apply. En bloc sending method should be used but overlap sending method is not ruled out.

#### 6.5.1.2 Called user migration

When the home SwMI of the called user is different from the originating SwMI (SwMI A), i.e. the called user home SwMI is SwMI B, and that user has migrated, two different cases arise depending on whether that user has migrated into a third SwMI (SwMI C, different from SwMI A) or into SwMI A (i.e. SwMI C coincides with SwMI A).

### 6.5.1.2.1 Called user having migrated in SwMI C different from SwMI A

If the called user has migrated into a third SwMI (SwMI C, different from SwMI A) and SwMI B has decided to continue the establishment of the call unless it cannot route it, the following shall apply to SwMI B, depending of the value of the information element routeing method choice, defined in table 79, in the ISI-SETUP PDU received from SwMI A:

- a) if the value of that information element routeing method choice corresponds to re-routeing not supported (by SwMI A):
  - if SwMI B supports forward switching and has decided to continue the establishment of the call in routeing it by forward switching, it shall send to SwMI C the ISI-SETUP PDU, defined in table 27. Except possibly for the value of the call priority information element (to be used according to the specifications of the supplementary services priority call and pre-emptive priority call), the values of the information elements of that ISI-SETUP PDU shall be identical to those in the ISI-SETUP PDU received from SwMI A except for the following ones (see note 1):
    - the value of the information element call has been forward switched shall indicate that the call has been forward switched;
    - the value of the information element last forwarding SwMI MNI (conditional on the value of the preceding information element indicating that the call has been forward switched) shall be equal to SwMI B MNI (which in that case will also be equal to the value of the information element called party extension);
    - the value of the information elements simplex/duplex selection and/or basic service information may be changed by SwMI B (home SwMI of the called user) if it knows that the called user does not support those in the ISI-SETUP PDU received from SwMI A. If SwMI B changes one of those values, it should inform SwMI A about that change in sending a PSS1 FACILITY message (see note 2) including the ISI-CALL PROCEEDING PDU, defined in table 33 (see note 3);
    - in addition, if as an option SwMI B supports fleet calling and if it finds out that the value information element called/forwarded-to party SSI in the ISI-SETUP PDU which it has received from the originating SwMI corresponds actually to a fleet call, the value of the information element called/forwarded-to party SSI shall be the actual SSI of the called/forwarded-to party, while the information element called/forwarded-to party fleet number SSI shall be present with the value of the information element called/forwarded-to party SSI in the ISI-SETUP PDU received from the originating SwMI (corresponding to the fleet number of the called/forwarded-to party). In addition the information element calling party fleet number SSI shall be present with a value equal to the fleet number SSI of the calling party;

or

- if SwMI B cannot route the call because it does not support forward switching (therefore cannot continue the establishment of the call) or because of congestion (whether internal or by lack of free ISI connection towards SwMI C), it shall send a PSS1 FACILITY message (see note 2) including the ISI-REDIRECT PDU, defined in table 29. The values of the information elements of that PDU shall be as follows:
  - the value of the information element "possible ISI trombone or loop connection detected" shall indicate that SwMI B has not identified that SwMI C coincides with SwMI A;
  - the value of the information element visited/forwarded-to SwMI MNI shall be equal to SwMI C MNI and the values of those on the PISN number of the visited/forwarded-to SwMI shall give the SwMI C PISN number to be used for routeing calls to the called user in SwMI C (see note 4);
  - the value of the information element routeing method response (see table 80) shall correspond to:
    - forward switching not supported, if SwMI B does not support forward switching; or
    - congestion in the SwMI sending this ISI-REDIRECT PDU;
  - the value of the information element SS-CF invocation counter shall be the same as that in the ISI-SETUP PDU received from SwMI A, and the value of the information element SS-CF information present shall indicate that no such information is present (see note 1);



- if the information element notification indicator is present, its value shall correspond to a notification addressed to the called user (and not to the calling user);
  - in addition, if as an option SwMI B supports fleet calling and if it finds out that the value information element called/forwarded-to party SSI in the ISI-SETUP PDU which it has received from the originating SwMI corresponds actually to a fleet call, the value of the information element called/forwarded-to party SSI shall be the actual SSI of the called/forwarded-to party, while the information element called/forwarded-to party fleet number SSI shall be present with the value of the information element called/forwarded-to party SSI in the ISI-SETUP PDU received from the originating SwMI (corresponding to the fleet number of the called/forwarded-to party). In addition the information element calling party fleet number SSI shall be present with a value equal to the fleet number SSI of the calling party;
- b) if the value of that information element routeing method choice corresponds to either "re-routeing supported (by SwMI A), forward switching (by SwMI B) preferred" or "re-routeing supported (by SwMI A), the called SwMI (i.e. SwMI B) may choose between forward switching and re-routeing":
- if SwMI B supports forward switching and has decided to continue the establishment of the call in forward switching it, it shall send to SwMI C the PSS1 SETUP message including ISI-SETUP PDU, defined in table 27. The specification of the values of the information elements of that ISI-SETUP PDU shall be the same as in case a) above (for the same PDU sent by SwMI B - to SwMI C); or
  - if SwMI B either does not support forward switching or has decided not to forward switch the call, it shall send to SwMI A a PSS1 FACILITY message (see note 2) including the ISI-REDIRECT PDU, defined in table 29. The specification of the values of the information elements of that ISI-REDIRECT PDU shall be the same as in case a) above, except that the value of the information element routeing method response shall correspond to "forward switching not supported" if SwMI B does not support forward switching or to "select re-routeing" if it supports forward switching but has decided not to forward switch the present call (instead of "forward switching not supported" or "congestion in the SwMI sending this ISI-REDIRECT PDU" in case a) above);
- c) if the value of that information element routeing method choice corresponds to re-routeing supported (by SwMI A), possible choice between forward switching and re-routeing to be made by originating/preceding SwMI (i.e. SwMI A), SwMI B shall send to SwMI A a PSS1 FACILITY message (see note 2) including the ISI-REDIRECT PDU, defined in table 29. The specification of the values of the information elements of that PDU shall be the same as in case a) above (for the same ISI-REDIRECT PDU sent by SwMI B), except that the value of the information element routeing method response shall correspond to forward switching supported or to forward switching not supported, depending on whether SwMI B supports forward switching or not (instead of forward switching not supported or select re-routeing in case b) above).

NOTE 1: The case of invocation of a call forwarding supplementary service in SwMI B (i.e. for the called user) is excluded in the present clause 6.5 (see clause 6.7 for such a case).

NOTE 2: The sending of the ISI-CALL PROCEEDING to SwMI A is compulsory in such a case because otherwise SwMI A would not be informed about the call modification - since SwMI C, the terminating SwMI, will itself not be aware of it.

NOTE 3: According to the PSS1 procedures for sending PSS1 FACILITY messages backwards, such messages will only be sent after the PSS1 CALL PROCEEDING message has been sent.

NOTE 4: According to EN 300 392-3-5 [4], the visited SwMI MNI will be delivered to SwMI B, the home SwMI of the migrating called user, from SwMI C, his visited SwMI, by ANF-ISIMM as part of the migration information for that user. In addition SwMI C may send, also as part of the migration information delivered by ANF-ISIMM, the PISN number (in the range of PISN numbers allocated to that SwMI) to be used for routeing calls to the called user in that SwMI. If such PISN number is not delivered by ANF-ISIMM, then the old SwMI will use the PISN number corresponding to the new SwMI MNI in its routeing table.

If SwMI A has received the PSS1 FACILITY message including the ISI-REDIRECT PDU, depending on the value of the information element routing method response in that PDU, it shall decide either to re-route the call or to have it forward switched (see note 5), towards SwMI C:

- if SwMI A decides to have the call forward switched, it shall send to the called SwMI the ISI-FORWARD SWITCH PDU defined in table 30 in a PSS1 FACILITY message. The called SwMI shall then send to the visited SwMI the PSS1 SETUP message including the ISI-SETUP PDU defined in table 27. The specification of the values of the information elements of that ISI-SETUP PDU shall be the same as in case a) above (for the same PDU sent by SwMI B - to SwMI C);
- if SwMI A decides to re-route the call, it shall:
  - initiate a new call establishment (see clause 6.5.1.1) in sending the PSS1 SETUP message including ISI-SETUP PDU, defined in table 27. The values of the information elements of that ISI-SETUP PDU shall be the same as those in the ISI-SETUP PDU sent previously to SwMI B except possibly for the values (see note 1):
    - of the call priority information element (to be used according to the specifications of the supplementary services priority call and pre-emptive priority call);
    - of the information element routing method choice, which shall correspond to SwMI A routing method choice (now related to its ISI connection with SwMI C) if further routing of the call by the invoked ANF-ISIIC was necessary because a call forwarding supplementary service has been invoked for the called user in SwMI C (not SS-CFU since SwMI C is the called user visited SwMI, but e.g. SS-CFU or SS-CFNRY); and/or
    - of the (optional) information element notification indicator, which shall be equal to that of the same information element received in the corresponding ISI-REDIRECT PDU. If that PDU did not include the information element notification indicator, the new ISI-SETUP PDU shall not include it either;

and

- send a PSS1 DISCONNECT message including the ISI-DISCONNECT PDU, defined in table 52, to clear the ISI connection between SwMI A and SwMI B previously seized by the invoked ANF-ISIIC, which has become unnecessary. In that PDU, the value of the information element disconnect cause, defined in table 60, shall correspond to call re-routed.

NOTE 5: While in theory nothing prevents SwMI A to decide to have the call forward switched (by SwMI B) if the value of the information element routing method response in the ISI-REDIRECT PDU which it has received corresponds to select re-routing (see case b) above), SwMI A should avoid it, since otherwise SwMI B could very well reject the corresponding request.

If the value of the information element routing method response in the ISI-REDIRECT PDU is inconsistent with that of the information element routing method in the corresponding ISI-SETUP PDU (e.g. SwMI A has indicated that it does not support re-routing and SwMI B has responded in requesting SwMI A to select re-routing, SwMI A shall send the PSS1 DISCONNECT message including the ROSE Return Error APDU with the cause corresponding to requestNotSupported (see clause 6.3.3) - thus clearing the ISI connection between SwMI A and SwMI B previously seized by the invoked ANF-ISIIC.

If the value of the information element routing method response in the ISI-REDIRECT PDU is consistent with that of the information element routing method in the corresponding ISI-SETUP PDU but does not allow SwMI A to continue the establishment of the call (e.g. SwMI A has indicated that it does not support re-routing and SwMI B has responded in indicating that it does not support forward switching or that it cannot forward switch the call due to congestion), SwMI A shall simply send the PSS1 DISCONNECT message including the ISI-DISCONNECT PDU, defined in table 52. In that PDU, the value of the information element disconnect cause, defined in table 60, should correspond to no possible routing of the call.

#### 6.5.1.2.2 Called user having migrated in SwMI C coinciding with SwMI A

If the called user has migrated into SwMI A (i.e. SwMI C coincides with SwMI A), this shall be identified by SwMI B if it has received the ISI-SETUP PDU from SwMI A (see note 1 below). SwMI B shall then send to SwMI A a FACILITY message including the ISI-REDIRECT PDU defined in table 29. The values of the information elements of that PDU shall be as follows:

- the value of both information elements "possible ISI trombone or loop connection detected" and "PDU addressed to originating SwMI" shall indicate that SwMI B has identified that SwMI C coincides with SwMI A, thereby forcing the call to be established as an intra-TETRA call (see note 1);
- the value of the information element SS-CF invocation counter shall be the same as that in the ISI-SETUP PDU received from SwMI A, and the value of the information element SS-CF information present shall indicate that no such information is present (see note 2);
- the value of the information element incoming call barring status (see note 3) shall indicate that neither the supplementary service barring of incoming calls nor that of call authorized by dispatcher for the called user have been activated;
- in addition, if as an option SwMI B supports fleet calling and if it finds out that the value information element called/forwarded-to party SSI in the ISI-SETUP PDU which it has received from the originating SwMI corresponds actually to a fleet call, the value of the information element called/forwarded-to party SSI shall be the actual SSI of the called/forwarded-to party, while the information element called/forwarded-to party fleet number SSI shall be present with the value of the information element called/forwarded-to party SSI in the ISI-SETUP PDU received from the originating SwMI (corresponding to the fleet number of the called/forwarded-to party). In addition the information element calling party fleet number SSI shall be present with a value equal to the fleet number SSI of the calling party.

NOTE 1: SwMI A may of course detect by itself (i.e. without the need to send the ISI-SETUP PDU to SwMI B and to receive back the ISI-REDIRECT PDU) that the called user is currently registered in that SwMI (after having migrated from SwMI B). However this is not mandatory. Furthermore, SwMI A cannot detect such case e.g. when the calling party addresses the called user using his MSISDN or his fleet number.

NOTE 2: The case of invocation of a call forwarding supplementary service in SwMI B (i.e. for the called user) is excluded in the present clause 6.5 (see clause 6.7 for such a case).

NOTE 3: The case of invocation of the supplementary services barring of incoming calls or call authorized by dispatcher for the called user is excluded in the present clause 6.5 (see clause 6.7 for such cases).

#### 6.5.1.3 Call characteristics and set-up time negotiation by the terminating SwMI

The terminating SwMI may indicate to the originating SwMI its fallback choice for some characteristics requested for the call in the PSS1 SETUP message that it cannot support (i.e. duplex selection, N slot bearer requested for a data call in the basic service information element, speech service) in sending the ISI-CALL PROCEEDING PDU, defined in table 33, else the ISI-INFO DEMAND PDU, defined in table 41, in a PSS1 FACILITY message. Note that contrary to the ISI-INFO DEMAND PDU, the ISI-CALL PROCEEDING PDU includes the information element call time-out, set-up time, defined in clause 6.3.2.1.3, which allows the terminating SwMI to inform the originating one about its call time-out in the set-up phase.

Instead of a FACILITY message including this ISI-CALL PROCEEDING PDU, the terminating SwMI may send a PSS1 FACILITY message including the ISI-SETUP PROLONGATION PDU, defined in table 34, if it only wants to inform the originating SwMI about its call time-out in the set-up phase (a priori, because it wants to have it modified). This shall hold until the terminating SwMI has received a PSS1 FACILITY message including the ISI-CONNECT ACKNOWLEDGE PDU, defined in table 35 (see clause 6.5.1.4).

NOTE 1: Hopefully, this call time-out in the set-up phase should be greater than or equal to that indicated by the originating SwMI in its PSS1 SETUP message.

Upon receiving this message, the originating SwMI call control application should ensure that the air interface CC entity extends its timer T302 (see table 58 of EN 300 392-2 [1], and the ANF-ISIIC entity should extend PSS1 timer T310 (see table 4 of ISO/IEC 11572 [9]), if necessary. If the call has been forward switched, by the called SwMI, the same should apply to the called SwMI.

NOTE 2: If PSS1 timer T310 is implemented in transit PINXs between the originating and the terminating SwMIs which are not part of the forward switching (called) SwMI, it will not be extended by this message.

NOTE 3: According to the PSS1 procedures for sending (PSS1) FACILITY backwards, such message will only be sent after the (PSS1) CALL PROCEEDING message has been sent.

After having received one of the above PSS1 FACILITY messages informing it about the terminating SwMI call time-out in the set-up phase, the originating SwMI may send a PSS1 FACILITY message including the ISI-SETUP PROLONGATION PDU, defined in table 34, if it wants to inform the terminating SwMI about its call time-out in the set-up phase. This shall hold until the originating SwMI has sent a PSS1 FACILITY message including the ISI-CONNECT ACKNOWLEDGE PDU, defined in table 35 (see clause 6.5.1.4).

NOTE 4: Having received a PSS1 FACILITY message from the terminating SwMI ensures that a signalling path exists with this SwMI.

#### 6.5.1.4 Call confirmation indication and call connected by the terminating SwMI

The procedures defined in ISO/IEC 11572 [9] for call confirmation indication and call connected shall apply.

If the terminating SwMI is instructed by the called user air interface U-ALERT PDU to use on/off hook signalling, it shall send the PSS1 ALERTING message including the ISI-ALERTING PDU, defined in table 31. If it is instructed by the called user air interface U-CONNECT PDU to use direct call set-up signalling, it shall send the PSS1 CONNECT message including the ISI-CONNECT PDU, defined in table 32. This shall be done immediately on the receipt of the U-CONNECT PDU even if the radio traffic channel resources required to support the called party are not yet available. The reservation state of the radio traffic channel resources is included into the ISI-CONNECT PDU as is the SwMIs allocation policy for radio traffic channel resources. The ISI-CONNECT PDU is sent immediately to avoid serial queuing for radio traffic channel resources.

All ISI PDUs sent after the ISI-CONNECT are contained in PSS1 FACILITY PDUs.

The terminating SwMI may use either of these PDUs to indicate to the originating SwMI its fallback choice for some characteristics that it cannot support (i.e. duplex selection, N slot bearer requested for a data call in the basic service information element and speech service; in addition, hook method selection but only in the PSS1 CONNECT message) among those requested for the call in the SETUP PDU received by this SwMI. Once such fallback choices shall have been indicated in a PSS1 message, they shall not be repeated in the next ones, i.e. the PSS1 ALERTING message for the PSS1 CONNECT message in the case of on/off hook signalling, and possibly a PSS1 FACILITY message (including the ISI-CALL PROCEEDING PDU, defined in table 33, else the ISI-INFO DEMAND PDU, defined in table 41) for the PSS1 ALERTING or CONNECT messages.

The terminating SwMI shall include the information element connected party fleet number SSI in that ISI-CONNECT PDU whenever the ISI-SETUP PDU, defined in table 27, which it has received included the information element called/forwarded-to party fleet number SSI (independently of whether or not the terminating SwMI supports fleet calling). The value of that information element connected party fleet number SSI shall be equal to that of the information element called/forwarded-to party fleet number SSI received.

To confirm that the call has actually been established on the calling user side, the originating SwMI shall acknowledge the PSS1 CONNECT message in sending to the terminating SwMI a PSS1 FACILITY including the ISI-CONNECT ACKNOWLEDGE PDU, defined in table 35. This is done by the originating SwMI only if it knows that itself and the terminating SwMI immediately have the necessary traffic channel resources to support the call. If this is not the case then an ISI-QUEUING PDU is sent instead.

If the terminating SwMI sent its ISI-CONNECT PDU before its radio traffic channel resources were reserved then, as soon as the resources are reserved it communicates this to the originating SwMI in an ISI-RESOURCE-RESPONSE PDU.

Either SwMI may operate different radio traffic channel resource allocation policies. They are either permanently allocated and are not released once obtained (except when the call is cleared) or temporarily allocated which means that before the maintenance phase has started they may be released if the call is delayed and cannot be connected. SwMIs with temporary radio traffic channel resource allocation also support extra signalling, based on the ISI-RESOURCE PDU, to synchronize when each SwMI both have their radio traffic channel resources available at the same time and to determine when the call may be connected. It is optional for a SwMI that has a permanent resource allocation policy if it supports the extra signalling or not.

After delaying the call (with an ISI-QUEUING PDU) and when the originating SwMI has obtained its radio traffic channel resource to connect its party into the call it can use the ISI RESOURCE PDU. It does this if the terminating SwMI is operating a policy of temporary resource allocation and the originating SwMI supports the signalling. The ISI-RESOURCE PDU asks the terminating SwMI for the allocation status of its radio traffic channel resources and if they are not available, for them to be obtained. If the terminating SwMI immediately has the resources available it responds with an ISI-RESOURCE-RESPONSE indicating this. If the resources are not available when the ISI-RESOURCE PDU arrives then this non-availability is indicated to the originating SwMI in an ISI-RESOURCE-RESPONSE PDU. When eventually the resources do become available in the terminating SwMI a second ISI-RESOURCE-RESPONSE PDU is sent indicating the availability of the resources.

When the originating SwMI receives an ISI-RESOURCE-RESPONSE indicating that radio traffic channel resources are reserved it may take one of two actions depending on the state of its own radio traffic channel resources. If they are still reserved, or can be obtained without queuing, then the call is finally connected with an ISI-CONNECT-ACKNOWLEDGE. If the radio traffic channel resources are not available then the call can be delayed again and an ISI-QUEUING PDU sent. This will cause the whole cycle to repeat again and many repeats are possible before the setup is successful, or is deemed to have failed.

In the usual case where a terminating SwMI has its radio traffic channel resources available when it sends the ISI-CONNECT PDU and when the originating SwMI obtains its resources immediately on the receipt of the ISI-CONNECT PDU the call is connected with ISI-SETUP-ACKNOWLEDGE straight away. The PDUs ISI-QUEUING, ISI-RESOURCE and ISI-RESOURCE-RESPONSE are not used in this case.

For SwMIs operating a "temporary" resource allocation policy, during call setup, they can make their radio traffic channel resources eligible for release on either the receipt or sending of an ISI-QUEUING PDU provided that this is not explicitly banned by parameter in the ISI-QUEUING.

If an originating SwMI does not support the extra signalling required for the release of resources then it will never use the ISI-RESOURCE PDU. If the terminating SwMI has a policy of temporary resource allocation then the call may still setup correctly depending on how the terminating SwMI handles this situation. This is an implementation specific matter. The originating SwMI will connect the call with an ISI-CONNECT-ACKNOWLEDGE once it has its own traffic channel resources and an ISI-RESOURCE-RESPONSE from the terminating SwMI indicating it has too.

#### 6.5.1.5 Failure of call establishment

If the call attempt is rejected by the terminating SwMI (because of e.g. incompatibility between the security levels at the calling and the called air interfaces, or internal congestion), by the called user (because e.g. it is busy, or end-to-end encryption was requested in the set-up and this user does not support it) or by the called SwMI when it is not the terminating SwMI, i.e. the called user has migrated, (because of e.g. unassigned number), the SwMI rejecting this call (or relaying the called user rejection) shall send a PSS1 DISCONNECT message including the ISI-DISCONNECT PDU, defined in table 52, with the appropriate disconnect cause.

The same shall apply if the terminating SwMI or, when it is not the terminating SwMI, the called SwMI rejects the call attempt in sending the PSS1 RELEASE COMPLETE message (see exception conditions defined in clause 10.2.2 of ISO/IEC 11572 [9] for the call clearing PSS1 protocol).

In addition, the establishment of the call may fail for a reason related only to the PSS1 procedure (i.e. not to ANF-ISIIC), e.g. no circuit channel available. The procedure defined in ISO/IEC 11572 [9] for failure of call establishment shall then apply. The inclusion of the ISI-DISCONNECT PDU, defined in table 52, in the corresponding PSS1 DISCONNECT or RELEASE COMPLETE message is then an implementation matter.

## 6.5.2 Call maintenance procedures

### 6.5.2.1 Transmission control procedures

As already stated in the stage 1 description, the originating SwMI shall be the controlling one. Consequently, it shall send to the terminating SwMI a PSS1 FACILITY message for every D-TX PDU to be sent by the latter to the called user. Each such PSS1 FACILITY message shall include a TETRA PDU corresponding to the relevant D-TX message. These TETRA PDUs are defined in tables 36, 37, 38, 39 and 40.

If either the originating SwMI or the terminating SwMI decides to interrupt the call (in sending the air interface D-TX WAIT PDU), it shall then send a PSS1 FACILITY message including the ISI-TX WAIT PDU defined in table 40 to the other end SwMI.

When the terminating SwMI sends an ISI-TX WAIT PDU, then the Transmission control request information element has no meaning and shall be set to value "Allowed to request for transmission".

The terminating SwMI shall relay to the originating SwMI the air interface U-TX PDUs that it receives to request transmission grant or inform that transmission has ceased, by sending a PSS1 FACILITY message including the TETRA PDUs defined in tables 43 and 44, respectively.

After the terminating SwMI has interrupted the call, to request to the originating SwMI the authorization to continue the call it shall send a PSS1 FACILITY message including the ISI-TX CONTINUE PDU defined in table 45. When the originating SwMI decides to remove the interrupt condition it shall send an ISI-TX-Continue to the terminating SwMI.

### 6.5.2.2 Call modification and/or continuation

To inform the other end SwMI that it wants to change the call time-out, the originating or the terminating SwMI shall send a PSS1 FACILITY message including the ISI-INFO DEMAND PDU defined in table 41.

NOTE 1: This SwMI should then wait for receiving an agreement from the other end SwMI before requesting the user that it is controlling to start timer T310 using this new call time-out value.

The same PSS1 FACILITY message can also be used to request from the other end some call modification (as specified in clause 14.5.1.2 of EN 300 392-2 [1]). The call time-out information element included in this TETRA PDU shall then be related to the modification requested.

Upon receiving the PSS1 FACILITY message including the ISI-INFO DEMAND PDU, the other end SwMI shall send a PSS1 FACILITY message including the ISI-INFO REPLY PDU defined in table 42.

NOTE 2: According to the negotiation clauses for incoming call in clause 14.5.1.1 of EN 300 392-2 [1] and to the definition of the class of MS (information) element in table 167 of EN 300 392-2 [1], possibly supplemented by information transferred by ANF-ISIMM, this other SwMI should always know whether the user that it controls would support the requested changes. This holds notably if the other user has requested a change (from simplex operation) to duplex operation or (from clear call) to encrypted call, which is possible according to clause 14.5.1.2 of EN 300 392-2 [1].

### 6.5.2.3 Call restoration

#### 6.5.2.3.1 General call restoration procedure

##### 6.5.2.3.1.1 Start of general call restoration procedure

When during an established (individual) inter-TETRA call, the call control application in the originating or in the terminating SwMI receives the information (from ANF-ISIMM) that the user (participating in the call) which was registered in the SwMI has migrated and is now registered in a new SwMI, the ANF-ISIIC entity invoked for that call should send a PSS1 SETUP message including the ISI-CALL RESTORE PREPARE PDU defined in table 46.

Similarly, in the case of migration of one of the two users involved in an intra-TETRA call established within a given SwMI, this SwMI should send to the new SwMI a PSS1 SETUP message including the same ISI-CALL RESTORE PREPARE PDU, defined in table 46.

NOTE: Formally, the SwMI call control application invokes then an ANF-ISIIC. It is that invoked ANF-ISIIC which triggers that PSS1 SETUP message.

In the procedure described below, the originating or terminating SwMI which sent the SETUP message as defined in either of the two preceding paragraphs shall be called the old SwMI.

At the same time that it sends the PSS1 SETUP message, the old SwMI shall start timer T1.

#### 6.5.2.3.1.2 Successful general call restoration

After the new SwMI has received the PSS1 SETUP message including the same ISI-CALL RESTORE PREPARE PDU, to indicate that it accepts to continue the ANF-ISIIC general call restoration procedure, it shall send a PSS1 CONNECT message including the ISI-CALL RESTORE PREPARED PDU, defined in table 47, if it has not yet received the call restoration message from its new visiting user, or the ISI-CALL RESTORATION PDU, defined in table 48, if it has received the call restoration message from its new visiting user in time.

If call restoration (by the migrating user) has occurred after the new SwMI has sent the PSS1 CONNECT message, it shall send the ISI-CALL RESTORATION PDU, defined in table 48, in a PSS1 FACILITY message.

When the old SwMI receives that ISI-CALL RESTORATION PDU (whether in a PSS1 CONNECT or FACILITY message) it shall transfer the call (by join), relay that PDU to the other end SwMI (in a PSS1 FACILITY message) and stop timer T1.

If the other end SwMI is itself engaged in an ANF-ISIIC call restoration procedure, it shall relay that ISI-CALL RESTORATION PDU to the new SwMI for that procedure.

#### 6.5.2.3.1.3 Failures cases of the general call restoration procedure

If no ISI connection can be established between the old SwMI and the new SwMI, the procedure defined in ISO/IEC 11572 [9] for failure of call establishment shall then apply. No TETRA PDU needs to be included in the corresponding PSS1 DISCONNECT or RELEASE COMPLETE message.

If the new SwMI does not support the ANF-ISIIC call restoration procedure (whether because it does not support call restoration at all, or only the ANF-ISIIC call restoration procedure), it shall send to the old SwMI a PSS1 FACILITY message including the ROSE Return Error APDU with the cause corresponding to requestNotSupported (see clause 6.3.3) in one of the following PSS1 messages clearing the ISI connection seized between the old and the new SwMIs either:

- a PSS1 RELEASE COMPLETE message if the corresponding exception condition defined in clause 10.2.2 of ISO/IEC 11572 [9] applies; or
- a PSS1 DISCONNECT message.

NOTE: See note in clause 6.3.3 if the new SwMI does not support ANF-ISIIC.

The old SwMI would then send the ISI-DISCONNECT PDU to the other end SwMI with the (ISI) disconnect cause: "ANF-ISIIC call restoration procedure not supported in new SwMI", possibly after having waited for a few seconds to send that message - the purpose of that delay is to keep the ISI connection in case the user who has migrated into the new SwMI would migrate back into the old SwMI very soon.

If the new SwMI supports the ANF-ISIIC call restoration procedure (which entails that it supports the air interface call restoration procedure) but decides to reject the set-up from the old SwMI for any other reason (because e.g. its air interface security level cannot match that used at calling user air interface), it shall send the same ISI-DISCONNECT PDU, defined in table 52, in clearing the ISI connection seized between the old and the new SwMIs. The value of the disconnect cause in that ISI-DISCONNECT PDU should indicate the other reason why the new SwMI has decided to reject the set-up from the old SwMI.

Upon expiry of timer T1 (i.e. because it has not received the ISI-CALL RESTORATION PDU before), the old SwMI shall release the ISI connection with the new SwMI that it had seized, in sending a PSS1 DISCONNECT message to that SwMI.

### 6.5.2.3.2 Specific call restoration procedure in a SwMI already on the path of the call

The following procedure is recommended instead of the general one specified in clause 6.5.2.3.1 above in the special cases where the new SwMI coincides with a SwMI already on the path of the call, i.e. when no call forwarding supplementary service is invoked: either the forward switching SwMI if the call has been forward switched or the other end SwMI (terminating or originating SwMI).

#### 6.5.2.3.2.1 Start of specific call restoration procedure

If an inter-TETRA call has been forward switched (i.e. when no call forwarding supplementary service is invoked: by the called user home SwMI), if migration of one of the two users engaged in that call occurs and if the new SwMI coincides with the forward switching SwMI, the old SwMI ANF-ISIIC entity should detect this and should then send to the forward switching/new SwMI a PSS1 FACILITY message including the ISI-PATH CALL RESTORE PREPARE PDU, defined in table 49.

Similarly, if instead of coinciding with the forward switching SwMI, the new SwMI coincides with the other end SwMI, the old SwMI ANF-ISIIC entity should detect this and should then send to the other end/new SwMI a PSS1 FACILITY message including the ISI-END CALL RESTORE PREPARE PDU, defined in table 50, unless it has already received the ISI-SIMULTANEOUS MIGRATION PDU as provided in the next paragraph.

NOTE 1: Clearly, the possibility of trombone (or more generally loop) connection is excluded in the case of migration of one of the two users involved in an established intra-TETRA call.

Still when the new SwMI coincides with the other end SwMI, the following shall apply if the other user migrates himself into a SwMI already on the path of the call after the first user (i.e. the user for whom the new SwMI has received the ISI-END CALL RESTORE PREPARE PDU) but before that first user has restored his side of the call and:

- if the SwMI into which the other user migrates is a SwMI through which the call has been forward switched and the new SwMI can identify it, that new SwMI shall send the ISI-SIMULTANEOUS MIGRATION PDU, defined in table 51, to the forward switching SwMI together with the ISI-PATH CALL RESTORE PREPARE PDU (i.e. in the same PSS1 FACILITY message). That case is shown as case a.1 in figure 23;
- if the SwMI into which the other user migrates is the old SwMI (i.e. the two users switch the SwMIs where they were previously registered), the new SwMI shall not send the ISI-END CALL RESTORE PREPARE PDU to the old SwMI for the other user migration but shall send instead a PSS1 FACILITY message including the ISI-SIMULTANEOUS MIGRATION PDU, defined in table 51. That case is shown as case a.2 in figure 23.

NOTE 2: The last indented paragraph means that when both users switch at about the same time the SwMIs where they were previously registered and this is identified by those SwMIs, the SwMI which is the first to identify the situation will not send the ISI-END CALL RESTORE PREPARE PDU but the ISI-SIMULTANEOUS MIGRATION PDU.

If one user migrates first into a SwMI through which the call has been forward switched, if the (end) SwMI where he was registered can identify it and if the other user migrates himself into that end SwMI after the first user but before that first user has restored his side of the call, that end SwMI shall send a PSS1 FACILITY message including the ISI-SIMULTANEOUS MIGRATION PDU, defined in table 51, to the SwMI where the first user has migrated (i.e. a SwMI through which the call has been forward switched). That case is shown as case b in figure 23.



NOTE 3: No need has been found to require the sending of a specific PDU if both users migrate at around the same time each into a SwMI through which the call has been forward switched and both the originating and the terminating SwMIs can identify it, because either:

- that SwMI will be the same for both users; or
- if both SwMIs are different, the only SwMI through which the call has been forward switched that the ANF-ISIIC routing procedure allows the originating SwMI to identify is the SwMI where the call has been forward switched for the first time, while for the terminating SwMI, it is the SwMI where the call has been forward switched for the first time. Consequently if the calling user migrates into that SwMI where the call has been forward switched for the first time, the clearing of the ISI connection between that SwMI and the originating SwMI, which is the main part of the successful call restoration as defined in the following clause, will be independent of whether or not the connected user is also migrating into that SwMI where the call has been forward switched for the last time; the same consideration will equally apply for the clearing of the ISI connection between the SwMI that SwMI where the call has been forward switched for the last time and the terminating SwMI.

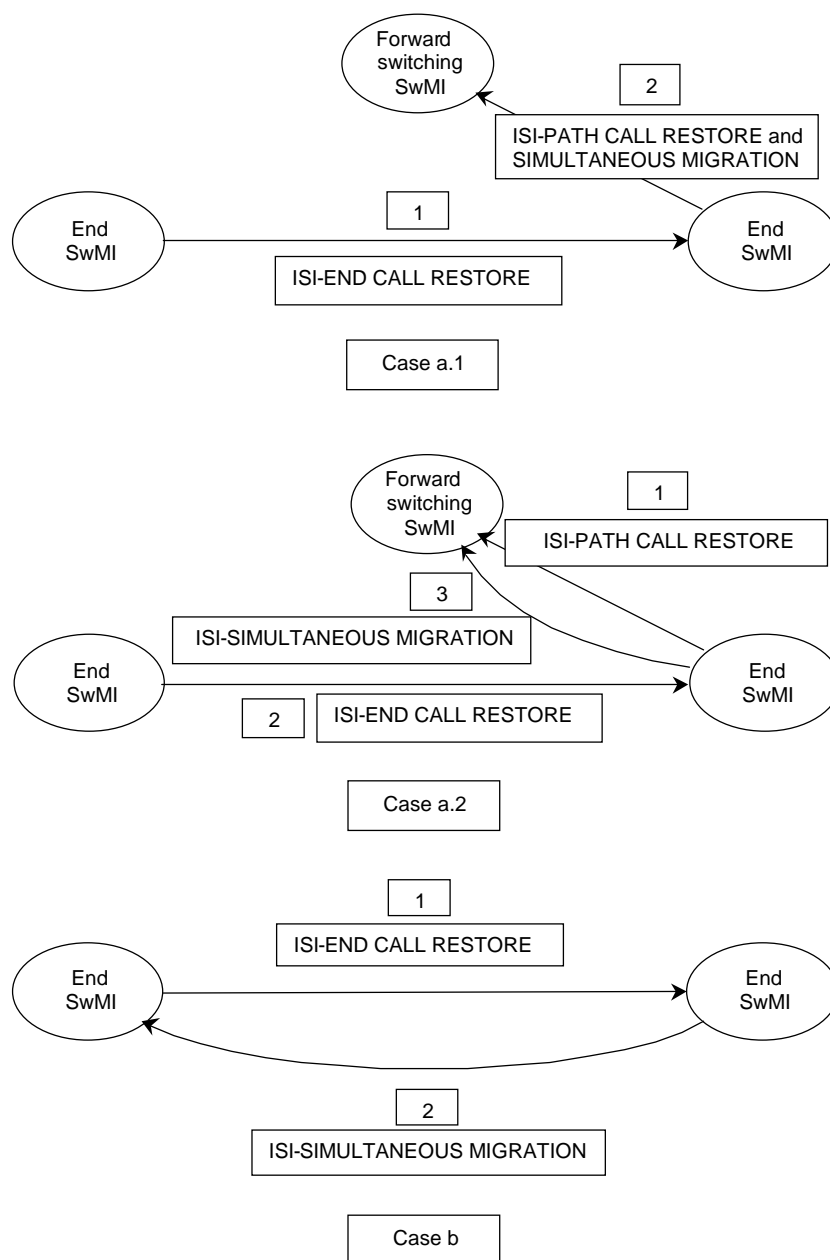

Figure 23: Simultaneous migration into SwMIs already on the path of the call

#### 6.5.2.3.2.2 Successful specific call restoration

After the new SwMI has received the ISI-PATH CALL RESTORE PREPARE PDU or the ISI-END CALL RESTORE PREPARE PDU, if it accepts to continue the corresponding ANF-ISIIC specific call restoration procedure, it shall send back to the old SwMI a PSS1 FACILITY message including the ISI-CALL RESTORE PREPARED PDU, defined in table 47, unless it has already successfully restored the call for its new visiting user in which case it shall send back to the old SwMI a PSS1 FACILITY message including the ISI-CALL RESTORATION PDU, defined in table 48.

If the new SwMI is a SwMI through which the call has been forward switched (i.e. it has received the ISI-PATH CALL RESTORE PREPARE PDU from the old SwMI), it shall send a PSS1 FACILITY message including the ISI-CALL RESTORATION PDU, defined in table 48, after it has successfully restored the call for its new visiting user:

- to the other end SwMI than the old SwMI if it has not received the ISI-SIMULTANEOUS MIGRATION PDU, defined in table 51 (from the old SwMI), before. It shall then wait for a few seconds after which if it has still not received the ISI-SIMULTANEOUS MIGRATION PDU it shall send to the old SwMI a PSS1 DISCONNECT message including the ISI-DISCONNECT PDU, defined in table 52 (see note). The value of the disconnect cause in that PDU, defined in table 60, shall correspond to call restored;

if the other end SwMI is itself engaged in an ANF-ISIIC call restoration SwMI procedure, it shall relay that ISI-CALL RESTORATION PDU to the new SwMI for that procedure.

- to the old SwMI if it has received the ISI-SIMULTANEOUS MIGRATION PDU, defined in table 51 (from the old SwMI), before. It shall then send to the other end SwMI than the old SwMI a PSS1 DISCONNECT message including the ISI-DISCONNECT PDU, defined in table 52, possibly after having waited for a few seconds to send that message (see note below). The value of the disconnect cause in that PDU, defined in table 60, shall correspond to call restored.

NOTE: The main purpose of the delay for sending the ISI-DISCONNECT PDU in the first case is to leave some time for the detection of a possible migration of the other user into the old SwMI slightly after that of the first migration (of the first user into the new SwMI). A secondary purpose of that delay is to keep the ISI connection in case the user who has migrated into the new SwMI would migrate back into the old SwMI very soon.

That secondary purpose is the only one in the second case.

In addition, still if the new SwMI is a SwMI through which the call has been forward switched, if that new SwMI receives the ISI-SIMULTANEOUS MIGRATION PDU (from the old SwMI) after it has already sent the ISI-CALL RESTORATION PDU to the SwMI at the other end of the old SwMI, it shall send a PSS1 FACILITY message including the ISI-CALL RESTORATION PDU, defined in table 48, to the old SwMI.

If the new SwMI is an end SwMI, (i.e. it has received the ISI-END CALL RESTORE PREPARE PDU from the old SwMI), the following shall apply after that SwMI has successfully restored the call for its new visiting user:

- if it has not detected that the user previously registered in that SwMI has himself migrated into a SwMI on the path of the call and if it has not received the ISI-SIMULTANEOUS MIGRATION PDU (from the old SwMI), it shall wait for a few seconds after which it shall send to the old SwMI a PSS1 DISCONNECT message including the ISI-DISCONNECT PDU, defined in table 52. The value of the disconnect cause in that PDU, defined in table 60, shall correspond to call restored;
- if it has detected that the user previously registered in that SwMI has himself migrated into a SwMI on the path of the call (either the other end SwMI, i.e. the old SwMI, a SwMI through which the call has been forward switched) or if it has received the ISI-SIMULTANEOUS MIGRATION PDU (from the old SwMI), it shall send a PSS1 FACILITY message including the ISI-CALL RESTORATION PDU, defined in table 48, to the SwMI on the path of the call already mentioned.

#### 6.5.2.3.2.3 Failures cases of the specific call restoration procedure

If the new SwMI has been identified by the old SwMI as being on the path of the call and does not support the ANF-ISIIC specific call restoration procedure (obviously it supports ANF-ISIIC in such a case - and it may or may not support the ANF-ISIIC general call restoration procedure), it shall send to the old SwMI a PSS1 FACILITY message including the ROSE Return Error APDU with the cause corresponding to requestNotSupported (see clause 6.3.3).

The old SwMI may then attempt the general ANF-ISIIC call restoration procedure. Otherwise it shall send the ISI-DISCONNECT PDU to the other end SwMI with the (ISI) disconnect cause: "ANF-ISIIC call restoration procedure not supported in new SwMI", possibly after having waited for a few seconds to send that message - the purpose of that delay is to keep the ISI connection in case the user who has migrated into the new SwMI would migrate back into the old SwMI very soon.

If the new SwMI is a SwMI through which the call has been forward switched (i.e. not an end SwMI) and supports the ANF-ISIIC call restoration procedure (which entails that it supports the air interface call restoration procedure) but decides to reject the set-up from the old SwMI for any other reason (because e.g. its air interface security level cannot match that used at calling user air interface), it shall send to the SwMI at the other end than the old SwMI the ISI-DISCONNECT PDU, defined in table 52, in a PSS1 DISCONNECT message, therefore clearing the call. The value of the disconnect cause in that ISI-DISCONNECT PDU should indicate the other reason why the new SwMI has decided to reject the set-up from the old SwMI.

### 6.5.3 DTMF procedures

The DTMF information shall be sent over the ISI in a PSS1 FACILITY message including the ISI-INFO DEMAND PDU defined in table 41 (see also clause 6.5.2.2).

NOTE: Since according to ISO/IEC 11582 [11], a PSS1 FACILITY can only be sent by the originating SwMI after a PSS1 signalling path has been established (i.e. a first PSS1 message has been received from the terminating or outgoing gateway SwMI, e.g. PSS1 ALERTING, CONNECT or FACILITY message), this SwMI will have to store the DTMF information that it has received before. Note that this may happen especially as according to EN 300 392-2 [1], the air interface U-INFO PDU which carry DTMF information can be sent as soon a call reference has been allocated by the (originating) SwMI.

### 6.5.4 ANF-ISIIC clearing

Specific cases of ANF-ISIIC clearing have already been addressed:

- in clause 6.5.1.2, i.e. complete clearing when the call turns out to be an intra-TETRA call, or only partial clearing, in case of re-routing;
- in clause 6.5.1.5, because of failure of the call establishment in the terminating SwMI, or in the called SwMI when those two SwMIs are different (i.e. because of called user migration or supplementary service operation - e.g. call authorized by dispatcher or call forwarding); and
- in clause 6.5.2.3, i.e. complete clearing when the call is restored as an intra-TETRA call, or only partial clearing, in case of call restoration in a SwMI already on the path of the call, different from the originating and terminating SwMIs).

When the call is cleared by the calling user or by the originating SwMI before the call has been established, the PSS1 DISCONNECT or RELEASE message sent by the originating SwMI according to the corresponding call clearing procedure defined in ISO/IEC 11572 [9] does not need to include any TETRA PDU.

When the calling user or a TETRA application in the originating SwMI clears the call is after it has been established, that SwMI shall send a PSS1 DISCONNECT message including the ISI-DISCONNECT PDU, defined in table 52. The information element disconnect cause of that TETRA PDU, defined in table 60, shall indicate the reason for that clearing.

The same shall apply when the call is cleared after it has been established:

- by the connected user or a TETRA application in the terminating SwMI, to the PSS1 DISCONNECT message sent by the terminating SwMI;
- by any TETRA application in a SwMI on the path of the call, different from the originating and terminating SwMIs, to the two PSS1 DISCONNECT messages sent by this SwMI, one in the backwards direction (that towards the originating SwMI) and the other in the forwards direction (that towards the terminating SwMI).

When the call is cleared because of failure of the PSS1 network (including failure of PSS1 protocol operation), no TETRA PDU needs to be included in the corresponding PSS1 clearing message.

## 6.5.5 Call collisions

In the case of call collision because two adjacent PISN nodes (including possibly the SwMIs involved in the call establishment or restoration) attempt both to seize the same PISN  $B_Q$  channel the procedure defined in ISO/IEC 11572 [9] for call collision shall apply.

In the specific case where an inter-TETRA call number 1 is being established and where the called user of this call is attempting to call the calling user at the same time the following shall apply:

- the two end SwMIs should identify this situation;
- then they should both compare the ITSIs of their respective calling and called users: the SwMI where the user with the larger ITSI number is registered shall be the leading SwMI;
- if the leading SwMI supports call amalgamation, it shall clear the ANF-ISIIC that it had invoked (for its outgoing ISI call attempt), amalgamate its calling user with the remaining invoked ANF-ISIIC (invoked by the other SwMI) and send the ISI-CONNECT PDU (in the PSS1 CONNECT message) for the latter ANF-ISIIC. Then the other SwMI will complete the call establishment;

NOTE 1: As a result of this procedure, the latter SwMI (i.e. the non-leading SwMI) will be the controlling SwMI.

- if the leading SwMI does not support call amalgamation, it will clear the ANF-ISIIC invoked (for its incoming ISI call attempt) by the other SwMI, since the called user for this invoked ANF-ISIIC is busy. Then:
  - if the other SwMI does not support call amalgamation, it will also clear the remaining invoked ANF-ISIIC (invoked by the leading SwMI), since the called user for this invoked ANF-ISIIC is also busy;
  - if the other SwMI supports call amalgamation, it shall amalgamate its calling user with the remaining invoked ANF-ISIIC (invoked by the leading SwMI) and send the PSS1 CONNECT message for the latter ANF-ISIIC. The leading SwMI will then complete the call establishment;

NOTE 2: As a result of this procedure, the leading SwMI will be the controlling SwMI.

- whether it is the leading SwMI or the other, the SwMI which amalgamates the call and sends the PSS1 CONNECT message shall set the information element hook method selection equal to direct set-up signalling in the ISI-CONNECT PDU sent in this PSS1 CONNECT message.

Figure 24 illustrates the procedure just described in the case where the leading SwMI supports call amalgamation.

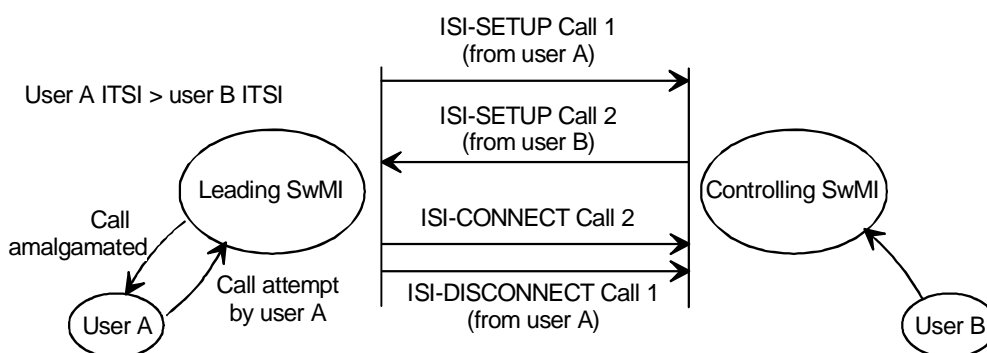

**Figure 24: Call collision handling in the case where the leading SwMI supports call amalgamation**

## 6.6 ANF-ISIIC impact of interworking with ISDN/PISN/PSTN

When a (TETRA) calling user requests the establishment of an external individual call through a TETRA gateway located in a SwMI different from that where that user is registered, the originating SwMI shall include both the ITSI number of this gateway and the external number in its ISI-SETUP PDU, as defined in table 27.

The gateway shall send to the originating SwMI the progress indicator elements and the connected number identity (if available) as specified in clause 6.2.6.

If these progress indicator elements cannot be sent either in the PSS1 ALERTING or the CONNECT message, the gateway SwMI shall send them in a PROGRESS message. This message may also include the ISI-PROGRESS PDU defined in table 28, to indicate to the originating SwMI its fallback choice for some characteristics requested for the call in the ISI-SETUP PDU that it cannot support (i.e. duplex selection, N slot bearer requested for a data call in the basic service information element, speech service). If the gateway SwMI does not send such fallback choice characteristics in the ISI-PROGRESS PDU (in a PSS1 FACILITY message), it shall send them in either the ISI-ALERTING PDU or the ISI-CONNECT PDU.

The fallback choice characteristics indicated as optional in the definitions of the TETRA PDUs concerned which have already been sent in a previous PSS1 message shall not be repeated (i.e. when identical to some already sent).

For an external incoming individual call (i.e. to a TETRA called user) routed over the ISI, the incoming gateway shall send the number of the calling party in the other network if available, in its ISI-SETUP PDU as defined in table 27. It shall also include in this message PSS1 information elements (notably the progress indicator elements) as defined in clause 6.2.5.

## 6.7 Protocol interactions between ANF-ISIIC and supplementary services and other ANFs

### 6.7.1 Interaction with SS-CLIR

In an individual inter-TETRA call, both the originating and the terminating SwMIs shall support SS-CLIR for the user at the other end (e.g. the terminating SwMI shall support SS-CLIR for the calling user).

If SS-CLIR has been invoked for the calling user, the following shall apply:

- the originating SwMI shall give to the information element "Calling party presentation indicator", defined in clause 6.3.2.2.12, in the ISI-SETUP PDU the value corresponding to presentation restricted;
- then, if the call is re-routed or forward switched, all ensuing ISI-SETUP PDUs shall have the same value of their information elements "Calling party presentation indicator";
- if the connected user migrates during the call and registers in a new SwMI, the terminating SwMI shall give to the information element "SS-CLIR invoked for other party", defined in table 86, in the ISI-CALL RESTORE PREPARE PDU or ISI-PATH CALL RESTORE PREPARE PDU sent to the new SwMI the value corresponding to SS-CLIR invoked for the other party. The same requirement shall then apply to the new SwMI if the connected user migrates again during the call.

If SS-CLIR has been invoked for the connected user, the following shall apply:

- the terminating SwMI shall give to the information element "Connected party presentation indicator", defined in clause 6.3.2.2.16, in the ISI-CONNECT PDU the value corresponding to presentation restricted;
- if the calling user migrates during the call and registers in a new SwMI, the originating SwMI shall give to the information element "SS-CLIR invoked for other party", defined in table 86, in the ISI-CALL RESTORE PREPARE PDU or ISI-PATH CALL RESTORE PREPARE PDU sent to the new SwMI the value corresponding to SS-CLIR invoked for the other party. The same requirement shall then apply to the new SwMI if the calling user migrates again during the call.

## 6.7.2 Interactions with SS-CF

### 6.7.2.1 Interaction with SS-CF at call establishment

When SS-CF has been invoked, the ANF-ISIIC procedure specified in clause 6.5 shall apply in replacing the called user by the forwarded-to user, SwMI A being the last SwMI on the path where the call has been forward switched, SwMI B being the SwMI where SS-CF has been invoked and SwMI C either the home SwMI of the forwarded-to user or the SwMI where that user has migrated. Notably if the call is re-routed, the following shall apply for the ISI-REDIRECT PDU, defined in table 29, sent by the SwMI where SS-CF has been invoked:

- its corresponding SS-CF information elements shall give the ITSI of the forwarded-to user;
- its migration information elements shall be present only if the home SwMI of that user coincides with the SwMI where SS-CF has been invoked and if that user has migrated: they shall then indicate the SwMI where he has migrated.

NOTE 1: The preceding indented paragraph means notably that if the home SwMI of the forwarded-to user is different from the SwMI where SS-CF has been invoked, the corresponding the ISI-REDIRECT PDU sent by that SwMI if SS-CF is operated by re-routeing will not include migration information elements.

NOTE 2: If the home SwMI of the called user coincides with the originating SwMI and that user has not migrated, clearly the call will be an intra-TETRA call. If in such a case SS-CF has been activated for the called user and if the forwarded-to user is registered in a different SwMI, SS-CF will invoke an ANF-ISIIC for the establishment of the call. The same may hold if the forwarded-to user is registered in the originating SwMI, that SwMI being (still) the home SwMI of the called user but not that of the forwarded-to user.

### 6.7.2.2 Specific interaction with SS-CFNry at call establishment

When SS-CFNry has been invoked, if the forwarded-to user MS/LS sends the U-ALERT PDU, this will never result in the PSS1 ALERTING PDU being sent twice on the same signalling connections. Therefore the accompanying ISI-ALERTING PDU, defined in table 31, shall not be sent twice across those same signalling connections. The ISI-INFO DEMAND PDU, defined in table 41, may be sent instead.

### 6.7.2.3 Interaction with SS-CF at call restoration

There shall be no interaction between ANF-ISIIC with SS-CF at call restoration, i.e. when a user migrates and registers in a new SwMI during an individual inter-TETRA call established with or more call forwardings, the call restoration procedure shall be the same as that described in clause 6.5.2.3.

This holds notably when the new SwMI coincides with a SwMI on the call path, i.e. either some forward switching SwMI if the call has been forward switched or the other end SwMI (terminating or originating SwMI).

NOTE 1: There is however a difference between call restoration of an individual inter-TETRA call established with or without call forwarding: for the latter only a trombone connection could result when the new SwMI coincides with a SwMI on the call path in the absence of trombone or loop detection by ANF-ISIIC, while a genuine loop connection may occur if many SS-CF have been invoked and more than one has been operated by forward switching. Such a case will arise when e.g. the connected user migrates either in an "upstream" forward switching SwMI (on the call path) or in the originating SwMI.

NOTE 2: The ISI trombone or loop connection detection recommended for the ANF-ISIIC call restoration should avoid such connection:

- in the case where call restoration happens for the connected user in the originating SwMI, or for the calling user, in the terminating SwMI;
- in the case where call restoration happens for the calling user in the forward switching SwMI just after the originating SwMI on the call path; and
- in the case where call restoration for the connected user in the forward switching SwMI just before the terminating SwMI on the call path.

Unfortunately, ANF-ISIIC will not be capable to detect a trombone or loop connection resulting from migration when the new SwMI coincides with any other forward switching SwMI. The reason for that is that neither the originating nor the terminating SwMIs are informed about all (forward switching) SwMIs on the call path.

## 6.7.3 Interaction with SS-CAD

### 6.7.3.1 Invocation of a specific ANF-ISIIC

When SS-CAD is invoked for an outgoing individual call and when the dispatcher is located in another SwMI, a specific ANF-ISIIC shall be invoked if the operation of SS-CAD entails the establishment of a call between the calling user and the dispatcher (i.e. diversion to the dispatcher). The corresponding TETRA PDU included in the PSS1 SETUP message for that call shall be the standard ISI-SETUP PDU (defined in table 27), i.e. no specific information element identifying this type of call shall be added to this TETRA PDU.

NOTE: Actually the PSS1 SETUP message will carry a specific SS-CAD PDU (CAD REQUEST PDU) in addition to the ISI-SETUP PDU - which is not an interaction.

The same shall apply if SS-CAD is invoked for an incoming individual intra-TETRA call and if the dispatcher is located in another SwMI.

### 6.7.3.2 Interception of an already invoked ANF-ISIIC

If SS-CAD has been invoked for an inter-TETRA individual call, the interaction between ANF-ISIIC and SS-CAD shall depend on whether or not SS-CAD operation entails the establishment of a call between the calling user and the dispatcher (i.e. diversion to the dispatcher).

If not, the invoked ANF-ISIIC shall simply be suspended in the SwMI where SS-CAD has been invoked. If yes, the corresponding call to the dispatcher shall be established by the ANF-ISIIC invoked for this inter-TETRA individual call: i.e. no additional ANF-ISIIC shall be invoked. To establish this call if the dispatcher is registered in a SwMI different from the SwMI where SS-CAD has been invoked, the already invoked ANF-ISIIC shall send the PSS1 SETUP message including the ISI-SETUP PDU, defined in table 27, and a specific SS-CAD PDU: CAD REQUEST PDU. The ensuing call to the dispatcher shall be established by forward switching (through the SwMI where SS-CAD has been invoked).

The information element "call diverted to a dispatcher" in the ISI-CONNECT PDU defined in table 32, sent in the PSS1 CONNECT message when the call is established with the dispatcher shall be set on.

NOTE: This caters for the case where the originating SwMI would not support SS-CAD, but would support e.g. SS-TPI or lawful intercept.

### 6.7.3.3 Call authorization by a distant dispatcher

If the dispatcher is registered in a SwMI different from the SwMI where SS-CAD has been invoked and if a call has been established between the calling user and the dispatcher, to authorize the establishment of the call originally requested to be resumed, the dispatcher SwMI shall send a PSS1 FACILITY message including a specific SS-CAD PDU: CAD ACCEPT PDU. That message shall be addressed to a PISN number which identifies the SwMI where SS-CAD has been invoked (i.e. where diversion to the dispatcher was initiated). This PISN number shall be determined using the MNI value of the SwMI received in the CAD REQUEST PDU mentioned in clause 6.7.3.2.

### 6.7.3.4 Completion of call establishment

#### 6.7.3.4.1 Call not diverted to dispatcher

Upon receiving the authorization to resume the call establishment, if the call has not been diverted to a dispatcher (i.e. no PSS1 CONNECT message has yet be sent to the originating SwMI) and if the called user has migrated, the call establishment shall proceed as defined in clause 6.5.1, starting from clause 6.5.1.2.

#### 6.7.3.4.2 Call diverted to dispatcher

Upon receiving the authorization to resume the call establishment, if the call has been diverted to a dispatcher and if the called user has migrated, the diverting SwMI shall send to the terminating SwMI the PSS1 SETUP message including the ISI-SETUP PDU, defined in table 27.

The contents of that ISI-SETUP PDU shall be the same as if the call had simply been forward switched and not been established before with the dispatcher (see paragraph a) of clause 6.5.1.2.1), except for the value of the information element transmission grant. The latter value shall be set in such a manner that it does not result in any change of transmission permission granted to the calling user, i.e.:

- if the calling user had been granted permission to transmit when the dispatcher authorizes the establishment of the call to be resumed, the diverting SwMI shall give to the information element transmission grant the value corresponding to transmission granted to another user (see table 126 of EN 300 392-2 [1]);
- if it is the dispatcher who had been granted permission to transmit when the dispatcher authorizes the establishment of the call to be resumed, the diverting SwMI shall give to the information element transmission grant the value corresponding to transmission granted (see table 126 of EN 300 392-2 [1]).

If the diverting SwMI is different from the originating SwMI, it shall:

- send a PSS1 FACILITY message including the ISI-TROUGH ALERTING PDU defined in table 53 to the originating SwMI if it receives from the terminating SwMI the PSS1 ALERTING message including the ISI-ALERTING PDU (defined in table 31);
- send a PSS1 FACILITY message including the ISI-TROUGH CONNECT PDU defined in table 54 to the originating SwMI when it receives from the terminating SwMI the PSS1 CONNECT including the ISI-CONNECT PDU (defined in table 32);
- the diverting SwMI shall then join the connection of the new call to the called/connected user with that of the original call from the calling user (through the originating SwMI) diverted to a dispatcher. In addition if that dispatcher was registered in a SwMI different from the diverting SwMI, the diverting SwMI shall send a PSS1 DISCONNECT message to the dispatcher SwMI to clear the connection of the original call with the dispatcher.

Whether or not it supports SS-CAD, the originating SwMI shall recognize the PSS1 FACILITY messages including the ISI-TROUGH ALERTING PDU, defined in table 53, and the ISI-TROUGH CONNECT PDU, defined in table 54, sent by the diverting SwMI as the true PSS1 ALERTING and CONNECT messages for the original call, respectively (including the ISI-ALERTING PDU, defined in table 31, and the ISI-CONNECT PDU, defined in table 32, respectively). Notably:

- upon receiving that PSS1 FACILITY message including the ISI-THROUGH CONNECT PDU, defined in table 54, it shall send to the terminating SwMI a PSS1 FACILITY message including the ISI-CONNECT ACKNOWLEDGE PDU, defined in table 35;
- the originating SwMI shall detect if any modification has occurred in the bearer service definition (i.e. change in the simplex/duplex selection, in the basic service or of CODEC) by analysing the contents of the corresponding information elements in the received ISI-TROUGH ALERTING or ISI-THROUGH CONNECT PDUs.

NOTE: The provision in the last paragraph is in line with the requirement in the stage 1 description (see clause 4.3.11) that the originating SwMI has to handle the set-up response that it receives as if no interception by the dispatcher had taken place; using stage 3 description terminology, this means as if it had received this response from the terminating SwMI in the PSS1 CONNECT message.

If the called user has migrated and is registered in the originating SwMI, then to avoid the overriding of dispatcher authorization by a local SS-BIC, the information element incoming call barring status, defined in table 70, in the ISI-REDIRECT PDU (see table 29) shall be set to call authorized by SS-CAD.

### 6.7.4 Interactions with SS-PC, SS-PPC and SS-CRT

To be defined.



### 6.7.5 Interaction with SS-CW

As already mentioned in clause 6.7.2.1 the PSS1 ALERTING PDU will never be sent twice on the same signalling connections. Therefore when, after SS-CW has been invoked by a user MS/LS, that MS/LS sends the U-ALERT PDU (after having become idle), the ISI-ALERTING PDU, defined in table 31, shall not be sent twice. The ISI-INFO DEMAND PDU, defined in table 41, may be sent instead.

NOTE: The definition of the information element call status, in table 58, has taken into account the possibility to inform the originating SwMI that SS-CW has been invoked using the ISI-ALERTING PDU, else the ISI-INFO DEMAND PDU.

### 6.7.6 Interaction with SS-HOLD

No interaction.

NOTE: The definition of the information element call status, in table 58, has taken into account the possibility to inform the other SwMI that SS-HOLD has been invoked using the ISI-INFO DEMAND PDU.

### 6.7.7 Interaction with SS-CCBS and SS-CCNR

The only interaction between ANF-ISIIC and SS-CCBS or SS-CCNR lies in the possibility for the originating SwMI to override the invocation of SS-CAD for the SS-CCBS or SS-CCNR recall (i.e. new call for successful SS-CCBS or SS-CCNR operation) if SS-CAD had been invoked for the failed call attempt which has resulted in SS-CCBS or SS-CCNR being invoked. Such overriding request shall be sent (by the originating SwMI) in the ISI-SETUP PDU using the information element override SS-CAD invocation, defined in table 73.

### 6.7.8 Interaction with SS-BIC

There is no protocol interaction when the terminating SwMI is the SwMI first called by the originating SwMI (because either the terminating SwMI is the called user home SwMI and this user has not migrated, or the originating SwMI is the called user home SwMI).

When the home SwMI of the called user is different from the originating SwMI, when this user has migrated and when SS-CAD for incoming calls has not been invoked, the invoked ANF-ISIIC has to ensure the operation of SS-BIC for the incoming call in the called user home SwMI unless a local SS-BIC applies (which overrules the "general" SS-BIC). Such local SS-BIC can only apply if the called user is registered in the originating SwMI (after having migrated). According to clause 6.5.4, this will be detected by the invoked ANF-ISIIC in the called user home SwMI (using the originating SwMI Mobile Network Identity (MNI)), which will then send a PSS1 FACILITY message including the ISI-REDIRECT PDU defined in table 29.

Consequently, the protocol interaction between ANF-ISIIC and SS-BIC consists only in having the information element incoming call barring status in that ISI-REDIRECT PDU set to either call barred by SS-BIC or call authorized by SS-BIC (see table 70).

NOTE: This applies only if SS-CAD for the incoming call has not been invoked, since it overrides SS-BIC.

### 6.7.9 Interactions with SS-AoC

If an advice of charge supplementary service is invoked for an inter-TETRA call at its set-up and if some charging information is to be got from another SwMI for operating that supplementary service, a specific SS-AoC PDU shall be included in the PSS1 SETUP message.

When the supplementary services SS-AoC-E or AoC-D have been invoked, independently of whether this is per call or for all calls, when the served user clears the call, instead of sending a PSS1 DISCONNECT message, the SwMI serving this user (e.g. the originating SwMI) shall send a PSS1 FACILITY message including a specific SS-AoC PDU to request charging information from other SwMI(s) on the path (e.g. the gateway or terminating SwMI) and to and to clear the call in delivering such information.

The charging information at the end shall be included in a specific SS-AoC PDU sent by the other end SwMI sent together with the ISI-DISCONNECT PDU defined in table 52 in a PSS1 DISCONNECT message.

### 6.7.10 Area Selection (SS-AS) and selected area number

The information element "selected area number" shall be carried in the TETRA ISI-SETUP PDU sent in the PSS1 call related SETUP message. The "selected area number" information element carries the same information as the "area selection" in the air interface, but adapted to the ISI signalling. The information element shall be used by the terminating SwMI during call set-up and may be used during call restoration. Refer to EN 300 392-12-8 [13] for the coding and usage of the selected area number information element.

### 6.7.11 Interactions with other supplementary services

At the time of the writing of the present document, no other supplementary service has been identified which would require for its invocation or its operation an interaction with ANF-ISIIC.

NOTE: Such supplementary services require only the transport of their PDUs (i.e. SS PDUs) through ANF-ISISS, as defined in clauses 9 and 10 of EN 300 392-9 [6].

## 6.8 ANF-ISIIC parameter values (timers)

ANF-ISIIC shall use the mandatory timers defined in ISO/IEC 11572 [9]. It shall not use the optional PSS1 timer T301 (for the outgoing side, started by the reception of the PSS1 ALERTING message, and stopped by that of the PSS1 CONNECT message (since it might conflict with the call set-up phase TETRA timer).

In addition, ANF-ISIIC shall use timer T1 as defined in clause 6.5.2.3, to protect against too much delay of call restoration while a connection between the old SwMI and the new SwMI has been established. The minimum value of this timer shall be 5 s, and its maximum value, 30 s.

## Annex A (informative): Static description of the TETRA individual call bearer service, using attributes

Reformulating the corresponding information defined in EN 300 392-2 [1] leads to the static description of TETRA bearer service attributes given below using the relevant attributes with the corresponding values as defined in ITU-T Recommendation I.140 [i.6].

- |                                     |   |
|-------------------------------------|---|
| 1) Information transfer mode:       | circuit.  |
| 2) Information transfer rate:       | from 2,4 kbit/s up to $4 \times 7,2$ kbit/s (= 28,8 kbit/s) (in the case of data transmission) - see clause 14.8.2 of EN 300 392-2 [1].   |
| 3) Information transfer capability: | all TETRA circuit mode bearer and tele- services.   |
| 4) Structure:                       | for single slot communications: "service data unit integrity" for telephony calls and for end-to-end encrypted data calls, and "unstructured" for other data calls;<br><br>for multislot communications: "Time Slot Sequence Integrity" (TSSI). |

NOTE: According to clause 4.5.1 of EN 300 392-2 [1] the air interface time slots comprise 510 bits (possibly only half, in special cases), sent at a data rate of 36 kbit/s (hence a timeslot duration of 14,167 ms). Depending on the type of traffic channel that they carry, these 510 bit time slots carry layer 3 service data units possibly completed by error control bits and interleaved between N time slots of different lengths (e.g. 432 bits for 7,2 kbit/s traffic channel, or 288 bits for 4,8 kbit/s traffic channel). The above statement about the value of the attribute structure in the case of telephony calls and of end-to-end encrypted data calls means that the corresponding layer 3 service data units have to be delivered transparently to the destination access point.

On the other hand, it is clear that the order of the time slots at the air interface should be kept end-to-end in multi-slot communications, hence the structure "TSSI".

- |   |  |
|---|--|
| 5) Establishment of communication:      | demand.  |
| 6) Symmetry:                            | bi-directional symmetric for duplex operation, and unidirectional for half-duplex operation.                 |
| 7) Communication configuration:         | point-to-point (since the communication is an individual call).  |
| 8) Access channel and rate:             | TDMA timeslot, at a rate of 9 kbit/s.  |
| 9) Access protocol:                     | air interface protocols for both signalling and user information - as defined in EN 300 392-2 [1].           |
| 10) Supplementary services provided:    | in line with ITU-T Recommendation I.210 [i.7], the definition of the value of this attribute is under study. |
| 11) Quality of service:                 | in line with ITU-T Recommendation I.210 [i.7], the definition of the value of this attribute is under study. |
| 12) Interworking capability:            | according to ITU-T Recommendation I.140 [i.6], the possible values of this attribute remain to be defined.   |
| 13) Operational and commercial aspects: | according to ITU-T Recommendation I.140 [i.6], the possible values of this attribute remain to be defined.   |

---

## Annex B (informative): Definition of the ISI ROSE operation

Refer to EN 300 392-3-1 [2] for the definition of the ISI ROSE operation.

---

## Annex C (informative): Interactions of SS-CFU with ANF-ISIIC

### C.1 Possible SS-CFU activation

Except for a possible local SS-CFU activation which is detailed below, if SS-CFU is activated this will be in the called user home SwMI.

As to the local SS-CFU activation, it may happen when the called user home SwMI is SwMI B (i.e. not SwMI A) and when this user has migrated and is now registered in SwMI A. It then only applies for intra-TETRA calls (within SwMI A).

This local SS-CFU activation is independent from that in the called user home SwMI (e.g. they can both take place).

When the called user migrates further, this local activation (in SwMI A) will be cancelled.

---

### C.2 Invocation and operation

Whenever ANF-ISIIC has been invoked, it interacts with SS-CFU if the latter has been activated (by the called user, this user being at the same time the SS-CFU served user). In addition, when the home SwMI of the called user is SwMI A, SS-CFU invokes ANF-ISIIC for forwarding the call if the forwarded-to user home SwMI is different from SwMI A, except possibly when the forwarded-to user happens to be registered in SwMI A after having migrated.

NOTE: In all cases addressed below, notification to the SS-CFU served user will be ensured by SS-CFU, by signalling (i.e. without any need to invoke ANF-ISIIC).

#### C.2.1 Called user home SwMI being SwMI A

In the case where the called user home SwMI is SwMI A and where this user has activated SS-CFU, the SS-CFU invoked (by SwMI A supplementary service control application) simply invokes ANF-ISIIC to forward the call if the forwarded-to user home SwMI is different from SwMI A, except possibly when the forwarded-to user happens to be registered in SwMI A after having migrated.

NOTE 1: When the forwarded-to user is registered in SwMI A after having migrated, whether or not SS-CFU will invoke ANF-ISIIC towards this user home SwMI depends on how SwMI A routes calls to called users registered in this SwMI when it is not their home SwMI (i.e. they have migrated). If SwMI A routes such calls directly (i.e. without invoking ANF-ISIIC), then SS-CFU will forward the calls directly instead of invoking ANF-ISIIC towards the forwarded-to user home SwMI.

When the forwarded-to user is registered in SwMI A after having migrated, if SS-CFU has invoked ANF-ISIIC (in SwMI A) to forward the call (i.e. SS-CFU has not routed the call directly, as an intra-TETRA call), the possible trombone will be identified by this invoked ANF which will then clear the call attempt.

NOTE 2: SS-CFU will then route the call internally.

#### C.2.2 Called user home SwMI being SwMI B

When the called user home SwMI is SwMI B, the ANF-ISIIC originally invoked for establishing the call with the called user invokes SS-CFU if it has been activated (by the called user) in this SwMI. This holds whether or not this user has migrated afterwards, except in the special case presented below.

NOTE 1: A different choice might have been made in the case where the called user has not migrated (being registered in SwMI B, its home SwMI): that of letting SwMI B supplementary service control application invoke SS-CFU. This choice was not made because it would have resulted in cascading two invoked ANF-ISIICs if the forwarded-to user is registered in some other SwMI, with more complex signalling.

In the special case where the called user (has migrated and) is now registered in SwMI A, where it has activated another SS-CFU in SwMI A for intra-TETRA calls (local call forwarding) and where SwMI A call control application has invoked ANF-ISIIC (to SwMI B) to establish the call with the called user, then this ANF will not invoke the SS-CFU activated in SwMI B (the called user home SwMI). Instead it reports to SwMI A call control application the information that the called user has migrated and is now registered in SwMI A, and clears itself.

NOTE 2: In such a case, SwMI A supplementary service control application should check whether or not a "local" SS-CFU has been activated for this called user. If yes, when the home SwMI of the forwarded-to user for this "local" SS-CFU is different from SwMI A, this "local" SS-CFU will invoke ANF-ISIIC as defined in clause C.2.1. If no, SwMI A call control application will establish the call to the called user, which would then be an intra-TETRA call.

NOTE 3: The additional condition above (in the last paragraph before note 2) that "the called user has activated another SS-CFU in SwMI A" results in the need for the invoked ANF to check whether a local SS-CFU has been activated before possibly invoking the home SwMI SS-CFU. And if a local SS-CFU has been activated, then, the invoked ANF will by-pass the invocation of the home SwMI SS-CFU (i.e. if a local SS-CFU has been activated, the home SwMI SS-CFU will not be invoked for the special case of intra-TETRA calls addressed in this last paragraph before note 2).

NOTE 4: On the other hand another issue arises if SwMI A call control application can route directly (i.e. without invoking ANF-ISIIC) calls to called users registered in this same SwMI when it is not their home SwMI (i.e. they have migrated). This issue is that, if no local SS-CFU has been activated, SwMI A supplementary service control application needs to be informed about the activation of SS-CFU in the called user home SwMI, to invoke it. This is why ANF-ISIMM will ensure that whenever a user which has activated SS-CFU in its home SwMI migrates to another network, the SwMI of this other network will be informed about this SS-CFU activation.

The definition of further interactions between SS-CFU and ANF-ISIIC depends on whether the forwarded-to user home SwMI:

- is SwMI B and this user is registered in its home SwMI;
- is SwMI B and this user has migrated;
- is different from SwMI B and this user is registered in its home SwMI;
- is different from SwMI B and this user has migrated.

In all those cases, if the forwarded-to user has itself activated a call diversion supplementary service, the ANF operation continues in invoking and operating the routing of this new call diversion supplementary service.

### C.2.2.1 Forwarded-to user with home SwMI being SwMI B, being registered in its home SwMI

If the forwarded-to user home SwMI is SwMI B and if this user is registered in its home SwMI, the ANF-ISIIC originally invoked to establish the call with the called user ensures SS-CFU routing (after having invoked it): i.e. by changing destination within SwMI B, to the forwarded-to user instead of to the called user.

### C.2.2.2 Forwarded-to user with home SwMI being SwMI B, having migrated

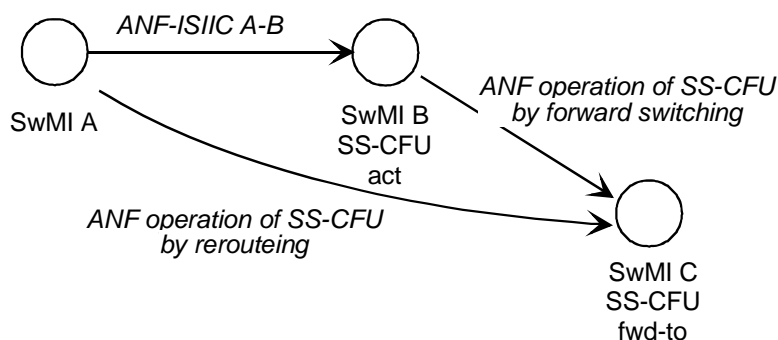

**Figure C.1: Interaction with SS-CFU  
Forwarded-to user with home SwMI being SwMI B, having migrated**

If the forwarded-to user home SwMI is SwMI B and if this user has migrated, as illustrated by figure C.1, the ANF-ISIIC originally invoked to establish the call with the called user ensures its routing by changing destination, to the forwarded-to user instead of to the called user. This routing is done by the ANF normal operation, that is either by re-routing or by forward switching.

NOTE: Compliance with the standards defining SS-CFU implies that SwMI B should support forward switching.

When SwMI C coincides with SwMI A, this will be identified by the ANF which then informs SwMI A call control application about the possible trombone and clears the call attempt. Moreover, the invoked ANF-ISIIC will also ensure that the routing of this new SS-CFU is established with no loop connection (notably no trombone connection) between the originating and the terminating SwMIs if it has previously invoked one or more call diversion supplementary services.

### C.2.2.3 Forwarded-to user with home SwMI different from SwMI B, being registered in its home SwMI

The same provisions as in clause C.2.2.2 apply if the home SwMI of the forwarded-to user is different from SwMI B and this user has not migrated.

### C.2.2.4 Forwarded-to user with home SwMI different from SwMI B, having migrated

In what follows, the home SwMI of the forwarded-to user (which is different from SwMI B) will be designated as SwMI B<sub>anf</sub>, with SwMI C designating the SwMI where this user has registered (after having migrated), and SwMI B<sub>fwd</sub>, the home SwMI of the SS-CFU served user (i.e. the called user). This is illustrated in figure C.2.

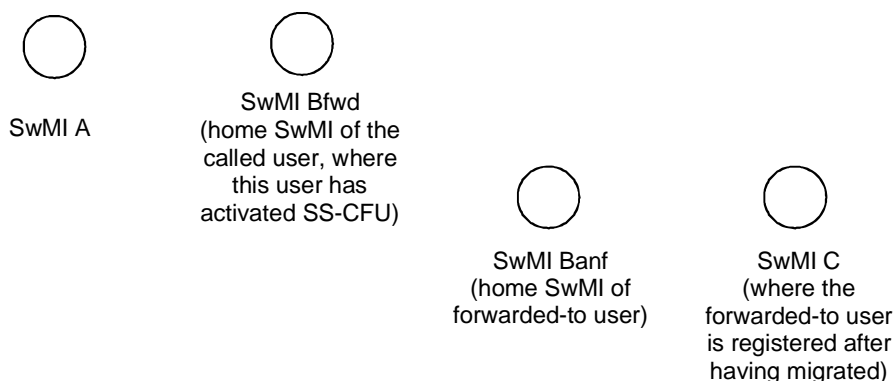

**Figure C.2: SwMI identification Forwarded-to user with home SwMI different from SwMI B, having migrated**

Case a) SwMI C different from SwMI B<sub>fwd</sub>

Once the ANF-ISIIC originally invoked to route the call to the called user has invoked SS-CFU, first, as in the case of clause C.2.2.2, it ensures the routing of the call attempt to SwMI B<sub>anf</sub> by changing destination, to the forwarded-to user instead of to the called user. Then since the forwarded-to user has migrated and is now registered in SwMI C, this ANF completes the routing of the call to the forwarded-to user.

This routing is done by the ANF normal operation, that is either by re-routing or by forward switching. However, instead of having the ANF deciding in a single step whether to re-route or forward switch the call (on the basis of information provided by a single SwMI B), the ANF operates in two steps, using:

- first the information provided by SwMI B<sub>fwd</sub> to either re-route the call (from SwMI A) to SwMI B<sub>anf</sub>, or forward switch it (through SwMI B<sub>fwd</sub>);
- then the information provided by SwMI B<sub>anf</sub> to again either re-route (either from SwMI A or from SwMI B<sub>fwd</sub>, depending on how the first step has been operated) the call or forward switch it (through SwMI B<sub>anf</sub>).

NOTE: This will result in the call being:

- fully re-routed (from SwMI A) to SwMI C;
- forward switched both through SwMI B<sub>fwd</sub> and through SwMI B<sub>anf</sub>; C (this case is shown in figure C.3);
- forward switched in SwMI B<sub>fwd</sub> and (partially) re-routed from SwMI B<sub>fwd</sub> to SwMI C; or
- re-routed from SwMI A to SwMI B<sub>anf</sub> and forward switched through SwMI B<sub>anf</sub> (this case is shown in figure C.4).

Of course, the choice of whether to re-route or forward switch the call may be restricted if SwMI A, SwMI B<sub>fwd</sub> and SwMI B<sub>anf</sub> do not support both modes of operation.

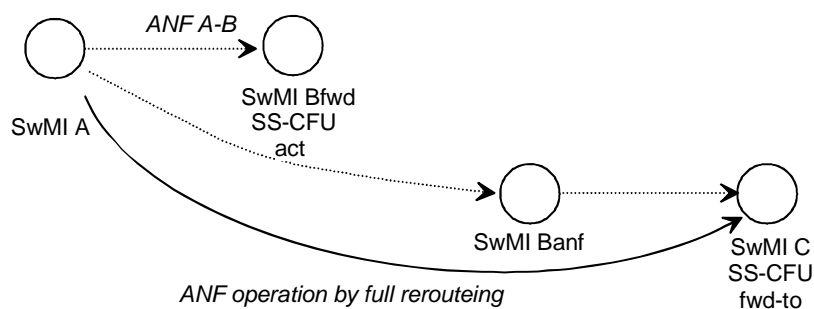

**Figure C.3: Interaction with SS-CFU re-routing Forwarded-to user with home SwMI different from SwMI B, having migrated ANF operation by full re-routing**



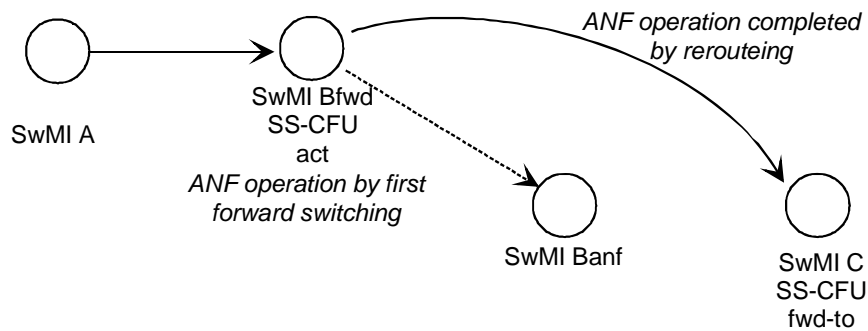

**Figure C.4: Interaction with SS-CFU operated by forward switching  
Forwarded-to user with home SwMI different from SwMI B, having migrated  
ANF operation by first forward switching and then re-routing**

When SwMI C coincides with SwMI A, this is identified by the ANF which then ensures that the call will be established with no loop connection. Moreover, the invoked ANF-ISIIC also ensures that this is the case between the originating and the terminating SwMIs if it has previously invoked one or more call diversion supplementary services.

**Case b) SwMI C coinciding with SwMI B<sub>fwd</sub>**

If SwMI C coincides with SwMI B<sub>fwd</sub> (i.e. the forwarded-to user is registered in SwMI B<sub>fwd</sub>), whether or not the invoked ANF-ISIIC routes the call attempt first towards SwMI B<sub>anf</sub> depends on whether or not SwMI B<sub>fwd</sub> is able to recognize that a call to a called user registered in this SwMI but with a different home SwMI (i.e. it has migrated into SwMI B<sub>fwd</sub>) is an intra-TETRA call without invoking ANF-ISIIC to the called user home SwMI.

If SwMI B<sub>fwd</sub> is not able to route such calls internally, then the interaction between SS-CFU operation and ANF-ISIIC is as specified in case a) above (case of SwMI C different from SwMI B<sub>fwd</sub>), except that when the call is not rerouted from SwMI A, the invoked ANF will avoid the trombone that would result from forward switching through SwMI B<sub>fwd</sub>.

If SwMI B<sub>fwd</sub> routes such calls directly, then the invoked ANF-ISIIC simply ensures the direct routing of SS-CFU (i.e. within SwMI B<sub>fwd</sub>). Moreover, the invoked ANF-ISIIC also ensures that this is the case between the originating and the terminating SwMIs if it has previously invoked one or more call diversion supplementary services.

## Annex D (informative): Change Requests

The present version of the present document contains information from change requests as indicated in the table D.1.

**Table D.1: Change Requests**

No	CR vers.	Standard Version	Clauses affected	Title	CR Status
001	REJ	V1.1.1	5.2.1.7	Transmission control for half duplex operation	Withdrawn
002	REJ	V1.1.1	5.2.1.7	Interruption of transmission	Withdrawn
003	APP	V1.1.1	5.2.2.14, 5.2.2.14.1 (new), 5.2.2.14.2 (new)	Stage 2 TX-CEASED definition	TETRA approved 0307
004	APP	V1.1.1	6.5.2.1	Transmission control procedures	TETRA approved 0307
005	Comb	V1.1.1	6.3.2.1.5, table 57	PDU type information element contents	Combined with 006
006	APP	V1.1.1	6.3.1.11, 6.3.1.13, 6.3.2.1.5	PDU types for ISI-TX-CONTINUE and ISI-TX CEASED PDUs	TETRA approved 0307
007	Comb				Combined with 006
008	APP	V1.1.1	6.3.1.12, Table 41.	Type 3 information element location in ISI-INFO REPLY PDU	TETRA approved 0307
009	App	V1.1.1	Annex "C"	Interactions of SS-CF with ANF-ISIIC	TETRA approved 0307
010	App	V1.1.1	4.2.2.2.8 (new section), 5.2.1.11 (new section), 6.3.1.1, 6.1.1.5, 6.3.1.6, 6.3.1.7, 6.3.1.10, 6.3.1.11, 6.3.1.12, 6.3.1.13, 6.3.1.15, 6.3.1.19 (new section), 6.3.1.20 (new section), 6.3.2.1.4, 6.3.2.1.5, 6.3.2.2.37, 6.3.2.2.41.A (new section), 6.3.2.2.41.B (new section), 6.3.2.2.41.C (new section), 6.3.2.2.44, 6.3.2.2.44, 6.5.1.4.	Alignment of the ETSI ANF-ISIIC with the approved MoU ISI IC TIP TTR 003-02 v1.8.2	TETRA approved 0307
011	APP	V1.1.1	6.3.1.11, 6.3.1.13, 6.3.2.1.5	Transmission request permission service/information element usage	TETRA approved 0307
101	20	V1.2.1	6.3.1.6, 6.3.1.19, 6.3.2.2.41a	Description of ISI-QUEUING PDU	WG3 approved 060131
201	12	V1.3.1	2, 2.1, 2.2, 4.2.2.2.1, 4.3.13, 6.7.10, 6.7.11	Selected area number information for ISIIC	WG3 approved 080408
202	10	V1.3.1	2.2, 3.1, 6.3.2.2.3	Fleet call	WG3 approved 080408
203	10	V1.3.1	5.2.1	Relationship between stage 2 information flows and stage 3 PDUs	WG3 approved 091112
204	10	V1.3.1	2.1, 6.3.2.1.4	Disconnect causes and other standards	WG3 approved 100202

---

## History

<b>Document history</b>		
V1.1.1	October 2000	Publication as TS 100 392-3-2
V1.1.1	December 2000	Publication
V1.2.1	January 2004	Publication
V1.3.1	July 2007	Publication
V1.4.0	April 2010	One-step Approval Procedure OAP 20100731: 2010-04-02 to 2010-08-02