

**V interfaces at the digital Local Exchange (LE);
V5.1 interface for the support of Access Network (AN);
Part 5: Test Suite Structure and Test Purposes (TSS&TP)
specification for the network layer (LE side)**



ReferenceREN/SPAN-09101-5

KeywordsV interface, V5 interface, LE, TSS&TP, testing,
AN, network**ETSI**

Postal addressF-06921 Sophia Antipolis Cedex - FRANCE

Office address650 Route des Lucioles - Sophia Antipolis
Valbonne - FRANCE
Tel.: +33 4 92 94 42 00 Fax: +33 4 93 65 47 16
Siret N° 348 623 562 00017 - NAF 742 C
Association à but non lucratif enregistrée à la
Sous-Préfecture de Grasse (06) N° 7803/88

Internetsecretariat@etsi.fr
Individual copies of this ETSI deliverable
can be downloaded from
<http://www.etsi.org>
If you find errors in the present document, send your
comment to: editor@etsi.fr

Important notice

This ETSI deliverable may be made available in more than one electronic version or in print. In any case of existing or perceived difference in contents between such versions, the reference version is the Portable Document Format (PDF). In case of dispute, the reference shall be the printing on ETSI printers of the PDF version kept on a specific network drive within ETSI Secretariat.

Copyright Notification

No part may be reproduced except as authorized by written permission.
The copyright and the foregoing restriction extend to reproduction in all media.

© European Telecommunications Standards Institute 1999.
All rights reserved.

Contents

Intellectual Property Rights.....	6
Foreword	6
1 Scope.....	7
2 References.....	7
3 Definitions and abbreviations	8
3.1 Definitions	8
3.2 Abbreviations.....	9
4 Test Suite Structure (TSS)	10
4.1 TSS overview.....	10
4.2 Test groups	11
4.2.1 Protocol groups	11
4.2.1.1 Control protocol	11
4.2.1.2 PSTN protocol.....	12
4.2.2 Main test groups.....	12
4.2.2.1 Basic Interconnection (IT) tests.....	12
4.2.2.2 Capability (CA) tests	12
4.2.2.3 Valid Behaviour (BV) tests	12
4.2.2.4 Inopportune Behaviour (BO) tests.....	12
4.2.2.5 Invalid Behaviour (BI) tests.....	12
4.2.2.6 Timer (TI) expiry and counter mismatch tests.....	12
4.2.2.6.1 Timer expiry and counters of the Control protocol.....	13
4.2.2.6.2 Timer expiry and counters of the PSTN protocol	13
4.2.2.6.3 Timer expiry and counters of the LE system management.....	13
4.3 Test step structure	14
4.3.1 State transitions	14
4.3.1.1 Startup of V5.1 interface	14
4.3.1.2 Common control Protocol (system management)	15
4.3.1.3 Control protocol (PSTN port FSM).....	16
4.3.1.4 Control protocol (ISDN-BA port FSM)	16
4.3.1.5 PSTN protocol.....	16
4.3.2 Preambles	17
4.3.3 Postambles	17
4.3.4 Status verification.....	17
4.3.4.1 PSTN protocol.....	17
4.3.4.2 Port control protocol.....	18
4.3.4.3 Common control protocol.....	18
4.3.5 Common test steps.....	18
4.4 Defaults.....	18
4.5 Abstract Service Primitives (ASPs) and Protocol Data Units (PDUs).....	19
4.5.1 ASPs.....	19
4.5.2 PDUs	19
4.5.2.1 Common control protocol.....	19
4.5.2.2 Port control protocol.....	19
4.5.2.3 PSTN protocol.....	19
4.5.3 Information elements.....	19
4.5.3.1 Variable length information elements.....	19
4.5.3.1.1 Control protocol.....	19
4.5.3.1.2 PSTN protocol	20
4.5.3.2 Single octet information elements.....	20
4.5.3.2.1 Control protocol.....	20
4.5.3.2.2 PSTN protocol	20
4.6 Timers and counters of the Abstract Test Suite (ATS)	20

5	Test Purposes (TPs)	21
5.1	Introduction.....	21
5.1.1	TP naming convention.....	22
5.1.2	Source of TP definition	22
5.1.3	Test strategy	23
5.1.4	Requirements not covered by TPs.....	23
5.1.5	Initial state.....	24
5.1.6	Test and data configuration requirements	24
5.2	Control protocol.....	24
5.2.1	Basic interconnection tests (V5NWKLE/CTRL/IT)	24
5.2.2	Capability tests (V5NWKLE/CTRL/CA).....	24
5.2.3	Valid behaviour tests (V5NWKLE/CTRL/BV)	25
5.2.3.1	V5NWKLE/CTRL/BV/COM.....	25
5.2.3.1.1	V5NWKLE/CTRL/BV/COM/TRANS	25
5.2.3.1.2	V5NWKLE/CTRL/BV/COM/REST	25
5.2.3.1.3	V5NWKLE/CTRL/BV/COM/REVEY	26
5.2.3.2	V5NWKLE/CTRL/BV/PORT.....	28
5.2.3.2.1	V5NWKLE/CTRL/BV/PORT/TRANS	28
5.2.3.2.2	V5NWKLE/CTRL/BV/PORT/PSTN	28
5.2.3.2.3	V5NWKLE/CTRL/BV/PORT/ISDNBA	30
5.2.4	Inopportune behaviour tests (V5NWKLE/CTRL/BO).....	35
5.2.4.1	V5NWKLE/CTRL/BO/COM.....	35
5.2.4.1.1	V5NWKLE/CTRL/BO/COM/TRANS	35
5.2.4.1.2	V5NWKLE/CTRL/BO/COM/REVEY	35
5.2.4.2	V5NWKLE/CTRL/BO/PORT.....	35
5.2.4.2.1	V5NWKLE/CTRL/BO/PORT/TRANS	35
5.2.4.2.2	V5NWKLE/CTRL/BO/PORT/ISDNBA	36
5.2.5	Invalid behaviour tests (V5NWKLE/CTRL/BI)	37
5.2.5.1	V5NWKLE/CTRL/BI/COM	37
5.2.5.1.1	V5NWKLE/CTRL/BI/COM/TRANS.....	37
5.2.5.2	V5NWKLE/CTRL/BI/PORT	38
5.2.5.2.1	V5NWKLE/CTRL/BI/PORT/TRANS	38
5.2.6	Timer expiry and counter mismatch tests (V5NWKLE/CTRL/TI)	39
5.2.6.1	V5NWKLE/CTRL/TI/COM.....	39
5.2.6.1.1	V5NWKLE/CTRL/TI/COM/TRANS.....	39
5.2.6.2	V5NWKLE/CTRL/TI/PORT	39
5.2.6.2.1	V5NWKLE/CTRL/TI/PORT/TRANS.....	39
5.3	PSTN Protocol.....	40
5.3.1	Basic interconnection tests (V5NWKLE/PSTN/IT).....	40
5.3.2	Capability tests (V5NWKLE/PSTN/CA).....	40
5.3.3	Valid behaviour tests (V5NWKLE/PSTN/BV).....	41
5.3.3.1	V5NWKLE/PSTN/BV/0	41
5.3.3.2	V5NWKLE/PSTN/BV/1	41
5.3.3.3	V5NWKLE/PSTN/BV/2	42
5.3.3.4	V5NWKLE/PSTN/BV/4	43
5.3.3.5	V5NWKLE/PSTN/BV/5	44
5.3.3.6	V5NWKLE/PSTN/BV/6	45
5.3.4	Inopportune behaviour tests (V5NWKLE/PSTN/BO).....	45
5.3.4.1	V5NWKLE/PSTN/BO/0	45
5.3.4.2	V5NWKLE/PSTN/BO/1	47
5.3.4.3	V5NWKLE/PSTN/BO/2	48
5.3.4.4	V5NWKLE/PSTN/BO/4	49
5.3.4.5	V5NWKLE/PSTN/BO/6	50
5.3.5	Invalid behaviour tests (V5NWKLE/PSTN/BI).....	51
5.3.5.1	V5NWKLE/PSTN/BI/1.....	51
5.3.5.2	V5NWKLE/PSTN/BI/4.....	52
5.3.6	Timer expiry and counter mismatch tests (V5NWKLE/PSTN/TI)	52
5.3.6.1	V5NWKLE/PSTN/TI/0.....	52
5.3.6.2	V5NWKLE/PSTN/TI/1.....	53
5.3.6.3	V5NWKLE/PSTN/TI/2.....	53

5.3.6.4	V5NWKLE/PSTN/TI/4.....	54
5.3.6.5	V5NWKLE/PSTN/TI/5.....	55
5.3.6.6	V5NWKLE/PSTN/TI/6.....	55
Bibliography		56
History		57

Intellectual Property Rights

IPRs essential or potentially essential to the present document may have been declared to ETSI. The information pertaining to these essential IPRs, if any, is publicly available for **ETSI members and non-members**, and can be found in SR 000 314: "*Intellectual Property Rights (IPRs); Essential, or potentially Essential, IPRs notified to ETSI in respect of ETSI standards*", which is available from the ETSI Secretariat. Latest updates are available on the ETSI Web server (<http://www.etsi.org/ipr>).

Pursuant to the ETSI IPR Policy, no investigation, including IPR searches, has been carried out by ETSI. No guarantee can be given as to the existence of other IPRs not referenced in SR 000 314 (or the updates on the ETSI Web server) which are, or may be, or may become, essential to the present document.

Foreword

This European Standard (Telecommunications series) has been produced by ETSI Technical Committee Services and Protocols for Advanced Networks (SPAN), and is now submitted for the Public Enquiry phase of the ETSI standards Two-step Approval Procedure.

The present document is part 5 of a multi-part EN covering the V5.1 interface for the support of Access Network (AN) as described below:

- Part 1: "V5.1 interface specification";
- Part 2: "Protocol Implementation Conformance Statement (PICS) proforma specification";
- Part 3: "Test Suite Structure and Test Purposes (TSS&TP) specification for the network layer (AN side)";
- Part 4: "Abstract Test Suite (ATS) and partial Protocol Implementation eXtra Information for Testing (PIXIT) proforma specification for the network layer (AN side)";
- Part 5: "Test Suite Structure and Test Purposes (TSS&TP) specification for the network layer (LE side)";**
- Part 6: "Part 6: Abstract Test Suite (ATS) and partial Protocol Implementation eXtra Information for Testing (PIXIT) proforma specification for the network layer";
- Part 7: "Test Suite Structure and Test Purposes (TSS&TP) specification for the data link layer";
- Part 8: "Abstract Test Suite (ATS) and partial Protocol Implementation eXtra Information for Testing (PIXIT) proforma specification for the data link layer";
- Part 9: "Test specification for the physical layer".

Proposed national transposition dates	
Date of latest announcement of this EN (doa):	3 months after ETSI publication
Date of latest publication of new National Standard or endorsement of this EN (dop/e):	6 months after doa
Date of withdrawal of any conflicting National Standard (dow):	6 months after doa

1 Scope

This fifth part of EN 300 324 contains the Test Suite Structure (TSS) and Test Purposes (TPs) for the Network layer (NWK) and parts of the system management of the Local Exchange (LE) side of a V5.1 interface.

The objective of the present document is to provide conformance tests giving a high probability of inter-operability of an Access Network (AN) and a LE from different manufacturers over the V5.1 interface. The present document covers the procedures described in EN 300 324-1 [1] only.

ISO/IEC 9646-1 [4] is used as the basis for the methodology of conformance testing.

Concerning the Public Switched Telephone Network (PSTN) protocol testing, only the procedures defined in EN 300 324-1 [1] are covered by the tests defined in the present document. An Implementation Under Test (IUT), however, will have implemented a national PSTN protocol part as well. This requires that the tester generates messages containing the national PSTN protocol specific optional Information Elements (IEs), otherwise the IUT would not act on messages according to the PSTN protocol procedure definition. However, this does not provide a comprehensive test of the national PSTN protocol mapping specification, which is outside the scope of the present document.

As the tests use PSTN messages containing optional IEs according to national specifications, the test result is only valid for the implemented national mapping of the V5.1 PSTN protocol.

The present document does not cover tests related to functions of the bearer channel. Those functions should be tested in conjunction with testing the national PSTN protocol mapping specification.

The present document contains no requirements concerning NWK tests for Integrated Services Digital Network Basic Access (ISDN-BA).

2 References

The following documents contain provisions which, through reference in this text, constitute provisions of the present document.

- References are either specific (identified by date of publication, edition number, version number, etc.) or non-specific.
- For a specific reference, subsequent revisions do not apply.
- For a non-specific reference, the latest version applies.
- A non-specific reference to an ETS shall also be taken to refer to later versions published as an EN with the same number.

- [1] EN 300 324-1: "V interfaces at the digital Local Exchange (LE); V5.1 interface for the support of Access Network (AN); Part 1: V5.1 interface specification".
- [2] EN 300 324-2: "V interfaces at the digital Local Exchange (LE); V5.1 interface for the support of Access Network (AN); Part 2: Protocol Implementation Conformance Statement (PICS) proforma".
- [3] ISO 7498: "Information Processing Systems - Open Systems Interconnection - Basic Reference Model".
- [4] ISO/IEC 9646-1: "Information technology - Open Systems Interconnection - Conformance testing methodology and framework - Part 1: General concepts".

3 Definitions and abbreviations

3.1 Definitions

For the purposes of the present document, the following terms and definitions apply, together with those given in EN 300 324-1 [1]:

abstract test case: refer to ISO/IEC 9646-1 [4]

abstract test suite: refer to ISO/IEC 9646-1 [4]

current provisioning variant: identifier for the presently active data set

data link layer: refer to ISO 7498 [3]

implementation under test: refer to ISO/IEC 9646-1 [4]

incorrect information element: specified information element carrying information types not defined in EN 300 324-1 [1]

invalid PSTN information element: PSTN information element not according to national specific requirements

invalid protocol data unit: PDU which contains an incorrect message format

invalid PSTN message: PSTN message carrying information elements not according to national specific requirements

lower tester: refer to ISO/IEC 9646-1 [4]

network layer: refer to ISO 7498 [3]

new provisioning variant: identifier for the data set which was announced to the IUT to become the next active data set through reprovisioning

physical layer: refer to ISO 7498 [3]

Protocol Implementation Conformance Statement (PICS): refer to ISO/IEC 9646-1 [4]

PICS proforma: refer to ISO/IEC 9646-1 [4]

specified information element: information element identifier defined in EN 300 324-1 [1]

system under test: refer to ISO/IEC 9646-1 [4]

test purpose: refer to ISO/IEC 9646-1 [4]

unknown provisioning variant: identifier for a non-available data set

unspecified information element: information element identifier not defined in EN 300 324-1 [1]

valid information element: PSTN information element according to national specific requirements

valid PSTN message: PSTN message carrying information elements according to national specific requirements

3.2 Abbreviations

For the purposes of the present document, the following abbreviations apply:

AN	Access Network
ASP	Abstract Service Primitive
ATC	Abstract Test Case
ATS	Abstract Test Suite
BI	Invalid Behaviour
BO	Inopportune Behaviour
BV	Valid Behaviour
CA	Capability
COM	Common control protocol
CTRL	Control
FE	Function Element
FSM	Finite State Machine
ID	Identifier
IE	Information Element
ISDN	Integrated Services Digital Network
ISDN-BA	ISDN-Basic Access
IT	Basic Interconnection
IUT	Implementation Under Test
L3addr	Layer 3 address
LE	Local Exchange
LT	Lower Tester
MDU	Management Data Unit
MPH	Management Physical Layer
NWK	Network Layer
PDU	Protocol Data Unit
PICS	Protocol Implementation Conformance Statements
PSTN	Public Switched Telephone Network
REST	Restart
REVV	Verify and Re provisioning
SUT	System Under Test
TI	Timer
TP	Test Purpose
TSS	Test Suite Structure

4 Test Suite Structure (TSS)

4.1 TSS overview

Figure 1 shows the structure of the V5.1 LE side NWK test suite.

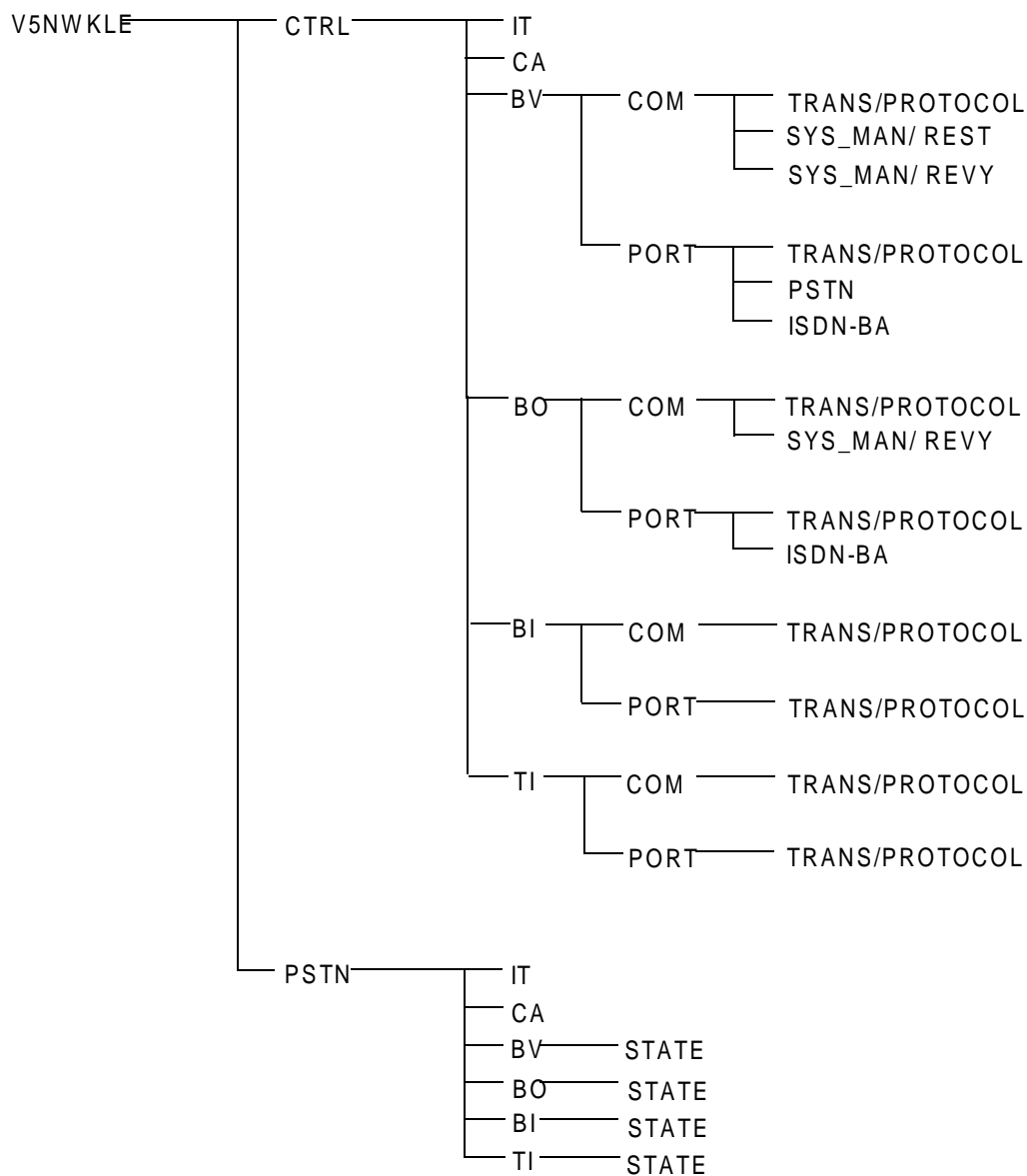

Figure 1: NWK LE TSS

4.2 Test groups

Figure 2 gives an overview of the various protocol entities of a V5.1 interface. Table 1 maps each protocol entity on tested protocol groups.

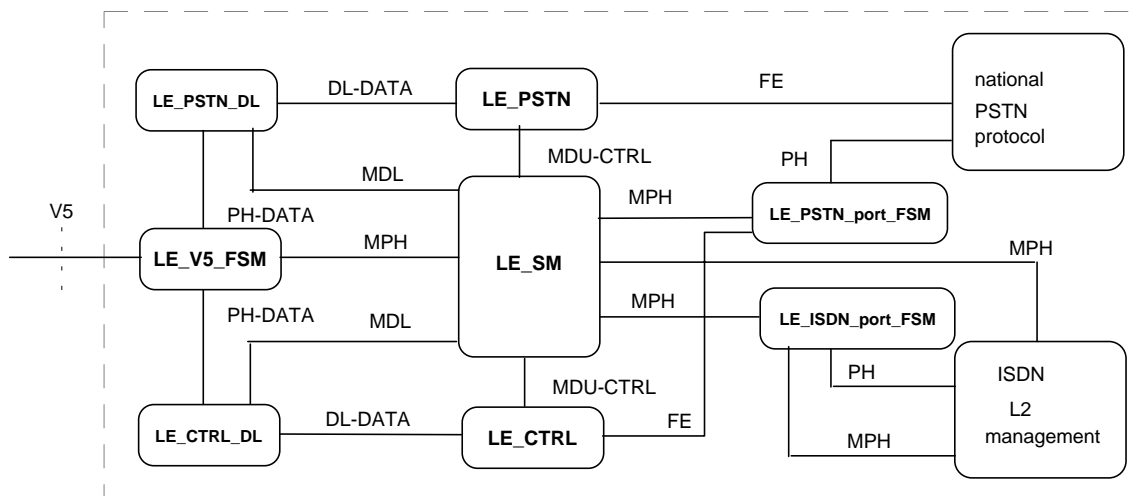

Figure 2: Network Layer LE - protocol entity overview

Table 1: Names used in figure 2 that correspond to EN 300 324-1 [1]

NWK protocol entities	Protocol entities defined in EN 300 324-1 [1]	Protocol group references
LE_PSTN_port_FSM	LE_PSTN_user_port_FSM	4.2.1.1
LE_ISDN_port_FSM	LE_ISDN-BA_user_port_FSM	4.2.1.1
LE_CTRL	LE_control_protocol	4.2.1.1
LE_SYS	LE_system_management	4.2.1.1
LE_PSTN	LE_PSTN_protocol	4.2.1.2

4.2.1 Protocol groups

4.2.1.1 Control protocol

All tests in the Control protocol (V5NWKLE/CTRL) test group are intended to verify as thoroughly as possible the various procedures of the LE_control_protocol entity. Depending on provisioning the following configurations are covered:

LE_system_management: the startup, restart, re-provisioning and verification procedures for normal operation of the LE_system_management (V5NWKLE/CTRL/BV/COM/REST, V5NWKLE/CTRL/BV/COM/REVV and V5NWKLE/CTRL/BO/COM/REVV) are tested.

LE_control_protocol: the normal and exceptional procedures of the LE_control_protocol are verified in the test groups V5NWKLE/CTRL/BV/COM/TRANS, V5NWKLE/CTRL/BO/COM/TRANS, V5NWKLE/CTRL/TI/COM/TRANS, V5NWKLE/CTRL/BV/PORT/TRANS, V5NWKLE/CTRL/BO/PORT/TRANS and V5NWKLE/CTRL/TI/PORT/TRANS. Contents of the LE_control_protocol values are not verified (e.g. the control function ID). The error handling procedures are verified in test groups V5NWLKE/CTRL/BI/COM/TRANS and V5NWLKE/CTRL/BI/PORT/TRANS.

LE_PSTN_user_port: the blocking, blocking request and co-ordinated unblocking procedures of the LE_PSTN_user_port_FSM are verified in the test group V5NWKLE/CTRL/BV/PORT/PSTN. The interworking of the LE_PSTN_user_port_FSM and the LE_PSTN protocol entity is tested via the LE_system_management.

LE_ISDN-BA_user_port: the blocking, blocking request, co-ordinated unblocking and activation/ deactivation procedures of the LE_ISDN-BA_user_port_FSM are verified in the test groups V5NWKLE/CTRL/BV/PORT/ISDNBA and V5NWKLE/CTRL/BO/PORT/ISDNBA.

4.2.1.2 PSTN protocol

All tests in the PSTN protocol (V5NWKLE/PSTN) test group are intended to verify as thoroughly as possible the various procedures of the LE_PSTN protocol entity.

The following PSTN procedures are covered:

- all path related normal operation procedures;
- significant path related exceptional procedures;
- the status enquiry procedure;
- the layer 3 error detection procedure;
- the error handling procedures;
- the port blocking procedure;
- the restart procedure.

4.2.2 Main test groups

4.2.2.1 Basic Interconnection (IT) tests

The IT test subgroup contains a basic set of TPs which assures that there is a sufficient conformance for interconnection and that the chosen parameters are valid for the configuration.

4.2.2.2 Capability (CA) tests

Capability testing provides a limited testing to ascertain the capabilities stated in the PICS can be observed.

4.2.2.3 Valid Behaviour (BV) tests

Predefined state transitions are considered as valid. The TPs in the BV test subgroup cover as far as reasonable the verification of the normal and exceptional procedures of the various Finite State Machines (FSMs).

A valid test is a test where the message sequence and the message contents is considered as valid (no error indication shall be indicated).

4.2.2.4 Inopportune Behaviour (BO) tests

This test group is intended to verify that the IUT is able to react properly in the case an inopportune protocol event occurring. Such an event is syntactically correct but occurs when it is not expected and an error indication is caused.

4.2.2.5 Invalid Behaviour (BI) tests

This test subgroup is intended to verify that the IUT is able to react properly having received an invalid Protocol Data Unit (PDU). An invalid PDU is defined as a syntactically incorrect message and therefore an error indication is caused.

4.2.2.6 Timer (TI) expiry and counter mismatch tests

Different timers and counters are defined to supervise the various state transitions. This test group is intended to verify that the FSM is reacting properly to an expiry of one of the timers or counter mismatch.

4.2.2.6.1 Timer expiry and counters of the Control protocol

Refer to EN 300 324-1 [1], table 58.

T01 PORT CONTROL message sent

T02 COMMON CONTROL message sent

4.2.2.6.2 Timer expiry and counters of the PSTN protocol

Refer to EN 300 324-1 [1], table 28.

T1 ESTABLISH sent

T3 DISCONNECT sent

T4 STATUS ENQUIRY sent

Tr SIGNAL received

Tt SIGNAL or PROTOCOL PARAMETER sent

Refer to EN 300 324-1 [1], subclause 13.5.5.

S(S) Sequence number of the next message to be sent

S(A) Sequence number of the last acknowledged message

S(R) Sequence number of the last received message

M(S) Send sequence number in SIGNAL or PROTOCOL PARAMETER messages

M(R) Receive sequence number in SIGNAL ACK messages

4.2.2.6.3 Timer expiry and counters of the LE system management

Refer to EN 300 324-1 [1], annex C, table C.1.

TR1 MDU-CTRL(restart request) to all PSTN protocol FSMs

TR2 MDU-CTRL(restart request) to or from CTRL protocol

TC1 MDL-RELEASE-INDICATION from CONTROL-DL

TC2 Expiry of TC1

TC3 MDL-RELEASE-INDICATION from PSTN-DL

TC8 Expiry of TC2

TC9 Cold restart of V5 interface

TV1 MDU-CTRL(request variant & interface ID) to CTRL protocol

4.3 Test step structure

General dynamic behaviours are described in test steps which can be called from all ATCs within the ATS:

- state transitions (refer to subclause 4.3.1)
- preambles (refer to subclause 4.3.2)
- postambles (refer to subclause 4.3.3)
- status checks (refer to subclause 4.3.4)
- common behaviours (refer to subclause 4.3.5)

4.3.1 State transitions

The following subclauses identify the test steps used in the ATS. In general, each test step represents a state transition. For example in the PSTN protocol, PSTN_LE1_2 is the test step which brings the LE PSTN protocol FSM from PSTN_path_state LE1 to PSTN_path_state LE2. The state transitions are declared in the parenthesis (originating state - destination state) which follow the test step names.

Three groups of state transitions are defined:

- STARTUP** startup the V5.1 interface and put the IUT into the initial state as defined in subclause 5.1.5.
- CTRL** state transitions used to preamble and postamble the Control protocol before a TP can be performed.
- PSTN** state transitions used to preamble and postamble the PSTN protocol before a TP can be performed.

To test the V5.1 interface certain sequences (i.e. preamble) shall be executed to reach the state which is the subject for the TPs.

4.3.1.1 Startup of V5.1 interface

The startup procedure for a V5.1 interface depends on the provisioned data configuration. Therefore, the two PICS items M1 and M2 (refer to subclause 6.5.1 of EN 300 324-2 [2]) are used to define the implemented configuration of the IUT.

NOTE 1: EN 300 324-2 [2] requires at least one of the two PICS items to be set to "Yes".

PICS item description:

- M1: ISDN-BA ports supported;
- M2: PSTN ports supported.

NOTE 2: One port of each supported type shall be provisioned in a way that the IUT tries to enter the operational state for these ports after system startup (see subclause 5.1.6).

Depending on the setting of the PICS items, the startup procedure is described in figure 3. This flow diagram describes the test step called STARTUP_LE.

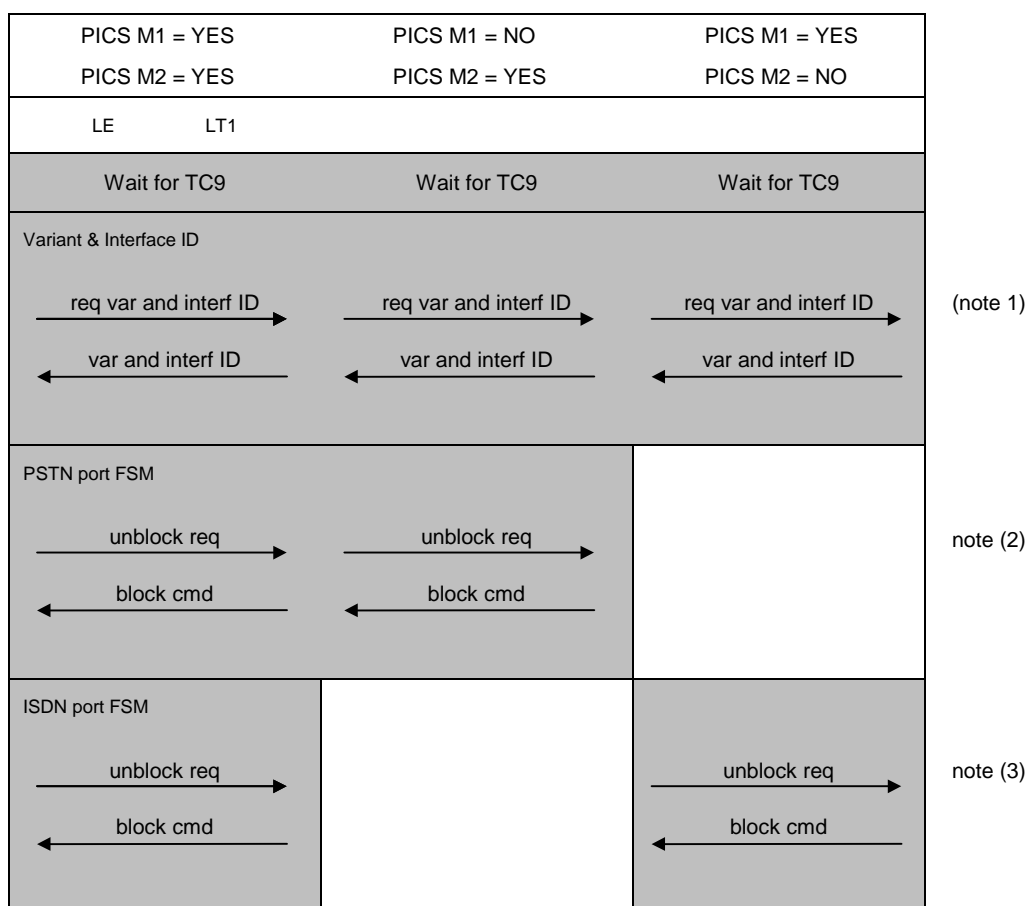

NOTE 1: A test of the IUT's capability of receiving a request for the variant and interface ID is covered in subclause 5.2.3.1.1.

NOTE 2: To reach the initial state of the IUT PSTN user port FSM as defined in subclause 5.1.5, the IUT's unblocking request is rejected by LT1. Before rejecting the unblock request, it shall be verified that the IUT PSTN protocol has entered the PSTN_path_state LE6 (Port blocked).

NOTE 3: To reach the initial state of the IUT ISDN-BA user port FSM as defined in subclause 5.1.5, the IUT's unblocking request is rejected by LT1.

Figure 3: STARTUP_LE flow diagram

4.3.1.2 Common control Protocol (system management)

Refer to EN 300 324-1 [1], table 62 and annex C.

CTRL_COM_LE0_1

On LE system startup (reset or initialization) the LE_CONTROL_DL shall be established between LE and LT1 and the common and port control protocol shall enter the In Service state LE1.

4.3.1.3 Control protocol (PSTN port FSM)

Refer to EN 300 324-1 [1], table 41.

CTRL_PSTN_LE20_10

On receipt of a PORT CONTROL message containing the control_function_element IE FE204 (block_cmd) the IUT PSTN user port FSM shall enter state LE1.0.

NOTE 1: This results in a state transition of the PSTN protocol as well. The PSTN protocol of the affected port is forced to enter the PSTN_path_state LE6.

CTRL_PSTN_LE10_20

On receipt of a PORT CONTROL message containing the control_function_element IE FE202 (unblock_req) the IUT shall respond with the PORT CONTROL message containing the control_function_element IE FE201 (unblock_ack) and then enter state LE2.0.

NOTE 2: This results in a state transition of the PSTN protocol as well. The PSTN protocol of the affected port is forced to enter the PSTN_path_state LE1.

4.3.1.4 Control protocol (ISDN-BA port FSM)

Refer to EN 300 324-1 [1], table 36.

CTRL_ISDNBA_LE20_10

On receipt of a PORT CONTROL message containing the control_function_element IE FE204 (block_cmd) the IUT ISDN-BA user port FSM shall enter state LE1.0.

CTRL_ISDNBA_LE10_20

On receipt of a PORT CONTROL message containing the control_function_element IE FE202 (unblock_req) the IUT shall respond with the PORT CONTROL message containing the control_function_element IE FE201 (unblock_ack) and the IUT ISDN-BA user port FSM shall then enter state LE2.0.

CTRL_ISDNBA_LE20_22

On receipt of a PORT CONTROL message containing the control_function_element IE FE104 (access_activated) the IUT ISDN-BA user port FSM shall enter state LE2.2.

4.3.1.5 PSTN protocol

Refer to EN 300 324-1 [1], table 30.

All messages sent within the test steps shall be valid PSTN messages.

PSTN_LEx_6 ≡ CTRL_PSTN_LE20_10 (refer to subclause 4.3.1.3)

On receipt of a PORT CONTROL message containing the control_function_element IE FE204 (block_cmd) the IUT PSTN protocol shall enter PSTN_path_state LE6.

PSTN_LE6_1 ≡ CTRL_PSTN_LE10_20 (refer to subclause 4.3.1.3)

On receipt of a PORT CONTROL message containing the control_function_element IE FE202 (unblock_req) the IUT PSTN protocol shall enter PSTN_path_state LE1.

PSTN_LE1_0

On receipt of a COMMON CONTROL message containing the control_function_ID "restart req" the IUT PSTN protocol shall enter PSTN_path_state LE0.

PSTN_LE0_1

On receipt of a COMMON CONTROL message containing the control_function_ID "restart complete" the IUT PSTN protocol shall enter PSTN_path_state LE1.

PSTN_LE1_2

On receipt of a terminating call request (FE-establish_request) the IUT PSTN protocol shall send an ESTABLISH message and enter PSTN_path_state LE2.

PSTN_LE4_5

On receipt of a SIGNAL message containing a faulty sequence number the IUT PSTN protocol shall send a DISCONNECT message and enter PSTN_path_state LE5.

4.3.2 Preambles

The preamble test step group contains test steps needed for initialization of the IUT before testing the particular TP. All combinations of the test steps defined in subclauses 4.3.1.2 to 4.3.1.5 can be used to create preambles. Each preamble shall start from the IUT initial state as defined in subclause 5.1.5.

4.3.3 Postambles

After each ATC the IUT shall be brought back to the initial state as defined in subclause 5.1.5. All combinations of the test steps defined in subclauses 4.3.1.2 to 4.3.1.5 can be used to create postambles.

4.3.4 Status verification**4.3.4.1 PSTN protocol**

Based on EN 300 324-1 [1], table 30, it is possible to identify the state of the IUT PSTN protocol FSM. All messages sent within the test steps shall be valid PSTN messages.

PSTN_CHECK_STATE_0 (Out of Service)

Run test step CTRL_PSTN_LE10_20.

On receipt of a DISCONNECT message the IUT PSTN protocol shall send a STATUS ENQUIRY message \Rightarrow the IUT PSTN protocol is not in one of the PSTN_path_states LE1 up to LE6.

Complete this test step by sending a STATUS message containing the state IE AN0.

PSTN_CHECK_STATE_1 (Null)

On receipt of an ESTABLISH ACK message the IUT PSTN protocol shall send a STATUS ENQUIRY message \Rightarrow the IUT PSTN protocol is not in one of the PSTN_path_states LE2 and LE5.

On receipt of a STATUS message containing the cause_type "response to status enquiry" and the state IE "AN1" the IUT PSTN protocol shall not send a DISCONNECT message \Rightarrow the IUT PSTN protocol is not in one of the PSTN_path_states LE3 and LE4.

On receipt of an ESTABLISH ACK message the IUT PSTN protocol shall send again a STATUS ENQUIRY message.

On receipt of a STATUS message containing the cause_type "response to status enquiry" and the state IE "AN5" the IUT PSTN protocol shall send a DISCONNECT message \Rightarrow the IUT PSTN protocol is not in one of the PSTN_path_states LE0 and LE6.

Complete this test step by sending a DISCONNECT COMPLETE message (IUT PSTN protocol enters the PSTN_path_state LE1).

PSTN_CHECK_STATE_2 (Path initiated by LE)

On receipt of a SIGNAL message the IUT PSTN protocol shall send a STATUS ENQUIRY message \Rightarrow the IUT PSTN protocol is not in one of the PSTN_path_states LE4 and LE5.

On receipt of a STATUS message containing the cause_type "response to status enquiry" and the state IE "AN1" the IUT PSTN protocol shall not send a DISCONNECT message \Rightarrow the IUT PSTN protocol is not in the PSTN_path_state LE3.

On receipt of a SIGNAL message the IUT PSTN protocol shall send again a STATUS ENQUIRY message.

On receipt of a STATUS message containing the cause_type "response to status enquiry" and the state IE "AN3" the IUT PSTN protocol shall send a DISCONNECT message \Rightarrow the IUT PSTN protocol is not in one of the PSTN_path_states LE0, LE1 and LE6.

Complete this test step by sending a DISCONNECT COMPLETE message (IUT PSTN protocol enters the PSTN_path_state LE1).

PSTN_CHECK_STATE_4 (Path active)

On receipt of an ESTABLISH message the IUT PSTN protocol shall send a STATUS ENQUIRY message ⇒ the IUT PSTN protocol is not in one of the PSTN_path_states LE1, LE2, LE3 and LE5.

On receipt of a STATUS message containing the cause_type "response to status enquiry" and the state IE "AN2" the IUT PSTN protocol shall send a DISCONNECT message ⇒ the IUT PSTN protocol is not in one of the PSTN_path_states LE0 and LE6.

Complete this test step by sending a DISCONNECT COMPLETE message (IUT PSTN protocol enters the PSTN_path_state LE1).

PSTN_CHECK_STATE_5 (Path disconnect request)

On receipt of a DISCONNECT message the IUT PSTN protocol shall send no DISCONNECT COMPLETE and no STATUS ENQUIRY message ⇒ the IUT PSTN protocol is not in one of the PSTN_path_states LE0, LE1, LE2, LE3, LE4 and LE6.

PSTN_CHECK_STATE_6 (Port blocked)

On receipt of a DISCONNECT message the IUT PSTN protocol shall send a STATUS ENQUIRY message ⇒ the IUT PSTN protocol is not in one of the PSTN_path_states LE1 up to LE5.

On receipt of a STATUS message containing the cause_type "response to status enquiry" and the state IE "AN6" the IUT PSTN protocol shall not send a DISCONNECT message.

Run test step CTRL_PSTN_LE10_11_20.

On receipt of a DISCONNECT COMPLETE message the IUT PSTN protocol shall not send a STATUS ENQUIRY message ⇒ the IUT PSTN protocol is not in the PSTN_path_state LE0.

4.3.4.2 Port control protocol**CHECK_PC_DISCARD**

Until time-out of timer T_NOAC no message shall appear on the V5 interface.

Afterwards teststep CTRL_PSTN_LE10_20 (refer to subclause 4.3.1.3) or CTRL_ISDNBA_LE10_20 (refer to subclause 4.3.1.4), depending on the affected port type is applied.

4.3.4.3 Common control protocol**CHECK_CC_DISCARD**

Until time-out of timer T_NOAC no message shall appear on the V5 interface.

On receipt of a COMMON CONTROL message containing the control_function_id IE "request variant & interface ID" the IUT shall send a COMMON CONTROL ACK message and a COMMON CONTROL message containing the control_function_id IE "variant & interface ID".

Complete this teststep by sending a COMMON CONTROL ACK message.

4.3.5 Common test steps

This test step group contains procedures which are used in more than one ATC.

4.4 Defaults

The default section describes the behaviour in case of an unexpected test event.

4.5 Abstract Service Primitives (ASPs) and Protocol Data Units (PDUs)

4.5.1 ASPs

The format of the two used ASPs is defined as described in EN 300 324-1 [1], subclause 13.4.

dl_data_req

dl_data_ind

4.5.2 PDUs

4.5.2.1 Common control protocol

ctrl_common_control

ctrl_common_control_ack

4.5.2.2 Port control protocol

ctrl_port_control

ctrl_port_control_ack

4.5.2.3 PSTN protocol

pstn_establish

pstn_establish_ack

pstn_signal

pstn_signal_ack

pstn_disconnect

pstn_disconnect_complete

pstn_status_enquiry

pstn_status

pstn_protocol_parameter

4.5.3 Information elements

4.5.3.1 Variable length information elements

4.5.3.1.1 Control protocol

ctrl_control_function_element

ctrl_control_function_id

ctrl_variant

ctrl_interface_id

4.5.3.1.2 PSTN protocol

pstn_sequence_number
 pstn_cadenced_ringing
 pstn_pulsed_signal
 pstn_steady_signal
 pstn_digit_signal
 pstn_recognition_time
 pstn_enable_autonomous_ack
 pstn_disable_autonomous_ack
 pstn_cause
 pstn_resource_unavailable
 pstn_enable_metering
 pstn_metering_report
 pstn_attenuation

4.5.3.2 Single octet information elements

4.5.3.2.1 Control protocol

ctrl_performance_grading
 ctrl_rejection_cause

4.5.3.2.2 PSTN protocol

pstn_line_information
 pstn_state
 pstn_autonomous_signalling_sequence
 pstn_sequence_response
 pstn_pulse_notification

4.6 Timers and counters of the Abstract Test Suite (ATS)

This subclause describes the timers and counters used in the ATS. The **min** and **max** indications define if the timer value represents the minimum or maximum limit of a timer. The timer values contain some additional tolerances for delays caused by test simulators. Therefore, a bigger timer tolerance is given than defined in EN 300 324-1 [1]:

Minimum value of ATS timer = EN timer - EN tolerance;

Maximum value of ATS timer = EN timer + 2 x EN tolerance.

The repetition of messages by the IUT shall be tested in the following way: the message has to be repeated within the time period $T_{\min} < T < T_{\max}$. This testing procedure applies to the tests in the TI test group only.

NOTE: Maximum values of some ATS timers are defined as test suite parameters.

Timers used in the ATS are given in *Timer Declarations* part of the ATS.

Table 2 gives the identified protocol counters used in the ATS and the references to EN 300 324-1 [1].

Table 2: Protocol counter values and references to EN 300 324-1 [1]

ATS counter name	ATS counter value	Explanation	Reference to EN 300 324-1 [1]
N01	1	Allowed number of repetitions of the PORT CONTROL message	clause 14, table 61
N02	1	Allowed number of repetitions of the COMMON CONTROL message	clause 14, table 62
N1	1	Allowed number of repetitions of the ESTABLISH message	clause 13, table 28
N3	2	Allowed number of repetitions of the DISCONNECT message	clause 13, table 28
N4	2	Allowed number of repetitions of the STATUS ENQUIRY message	clause 13, table 28

5 Test Purposes (TPs)

5.1 Introduction

For each test requirement, a TP is defined.

This subclause details the TPs for the LE side of NWK of the V5.1 interface for each test group and references to the corresponding ATC.

At the beginning of each test subgroup the initial state (refer to subclause 5.1.5), the preambles (refer to subclause 4.3.2) and the postambles (refer to subclause 4.3.3) are listed.

5.1.1 TP naming convention

The identifier of the TP is constructed according to the scheme in table 3.

Table 3: TP identifier naming convention scheme

Identifier: TP<t><c><g1><g2><tpt><s><ss><nn>				
<t>	=	type of protocol: (test group)	1	Control protocol
			2	PSTN protocol
<c>	=	category: (test subgroup)	1	IT, Basic Interconnection Tests
			2	CA, Capability Tests
			3	BV, Valid Behaviour Tests
			4	BO, Inopportune Behaviour Tests
			5	BI, Invalid Behaviour Tests
			6	TI, Timer Expiry and Counter Mismatch
<g1>	=	group level 1:	1	Common control
			2	Port control
			–	(underscore) not relevant
<g2>	=	group level 2:	1	Transport
			2	System management procedure Restart
			3	System management procedure Re-provisioning & Verification
			4	PSTN
			5	ISDN BA
			–	(underscore) not relevant
<tpt>	=	test purpose type:	S	Single
			–	(underscore) not relevant
<s>	=	state:	(0-9)	
			M	Multiple state transition
			–	(underscore) not relevant
<ss>	=	substate:	(0-9)	
			–	(underscore) not relevant
<nn>	=	sequential number:	(01-99)	

5.1.2 Source of TP definition

The TPs were developed based on EN 300 324-1 [1], clauses 13 and 14, and annex C.

5.1.3 Test strategy

To achieve a maximum of test coverage with an appropriate number of TPs the following selection criteria have been applied:

- a) only the first up to the third value of the PSTN sequence number variables S(S), S(A), S(R), M(S), M(R) is covered;
- b) the error handling procedures of the Control and PSTN protocol are not exhaustively tested. Not all possible combinations of protocol errors in all protocol states are covered. The TPs cover only examples for each error handling procedure:
 - 1) for the PSTN protocol applications the error handling procedures are tested in PSTN_path_state LE1. To easily perform some of the test cases, some procedures are tested in PSTN_path_state LE4;
 - 2) for the Control protocol applications the error handling procedures are tested in state LE1 of the Common and Port control protocol. During these tests the PSTN and ISDN-BA user port FSMs stay in state LE1.0;

The procedure for unexpected events of the PSTN protocol is exhaustively tested (all unexpected events in all PSTN_path_states are covered);
- c) for several TPs some activities by the testing person are required (invoking of certain procedures by the System Under Test (SUT)). These TPs are marked with (*);
- d) the Port control protocol, the Common control protocol (COM), the ISDN-BA user port FSM and the PSTN user port FSM are not tested on a per-state basis. The TPs step through the FSMs by testing the procedures and supervising the behaviour of the IUT at the interface.

5.1.4 Requirements not covered by TPs

- a) since PSTN_path_state LE3 of the PSTN protocol (Path initiated by AN) is only transient and fully controlled by the national protocol, it is only possible to test the straightforward path related procedure in this state;
- b) since all FEs are fully controlled by the national protocol, it is only possible to test the straightforward FE-inputs to the PSTN state machine;
- c) it is not possible to explicitly verify the state of the COM, the Port control protocol, the ISDN-BA user port FSM and the PSTN user port FSM;
- d) the correct use and implementation of national dependent optional IEs within the PSTN protocol is not tested (refer to annex D of EN 300 324-1 [1]):
 - 1) the capability of the LE to send PSTN messages in all sequences required by the implemented national mapping;
 - 2) the capability of the LE to send PSTN messages containing all combinations of optional IEs required by the implemented national mapping;
- e) as the system reaction on the time-out of system management timers is not specified, these time outs are not tested;
- f) state transitions which are defined by the characters "/" or "-" are only tested if the events are V5-messages or timer expirations;
- g) the generation of error indications is not tested.

5.1.5 Initial state

The initial states of the various V5.1 protocols are defined as follows:

CTRL_COM_INIT Initial state to start the preamble of the CTRL_COM TPs
LE1 (In Service), for COM

CTRL_PORT_INIT Initial state to start the preamble of the CTRL_PORT TPs
LE1 (In Service), for Port control protocol

LE1.0 (Blocked), for PSTN and ISDN-BA user port FSMs

PSTN_INIT Initial state to start the preamble of the PSTN TPs
LE6 (Port blocked), for PSTN protocol FSMs

5.1.6 Test and data configuration requirements

According to EN 300 324-2 [2], the IUT shall support either ISDN-BA ports or PSTN ports or both. For the aim of the conformance testing only one port of each supported type shall be provisioned.

Each user port shall be provisioned in a way that the IUT tries to enter the operational state for these ports after system startup.

For testing the PSTN protocol, the IUT shall be able to apply terminating calls on a PSTN port on the V5 interface.

5.2 Control protocol

5.2.1 Basic interconnection tests (V5NWKLE/CTRL/IT)

Initial state of the IUT: power on

Preamble: reset IUT

Postamble: -

TP11__SM_01 Run the test step STARTUP_LE (refer to subclause 4.3.1.1)
(*)

5.2.2 Capability tests (V5NWKLE/CTRL/CA)

Refer to EN 300 324-1 [1], tables 61 and 62.

Initial state of the IUT: CTRL_COM_INIT, CTRL_PORT_INIT

Preamble: -

Postamble: -

TP12__S1_01 On receipt of a COMMON CONTROL message containing the control_function_id IE "variant & interface id", the IUT shall send a COMMON CONTROL ACK message containing the same control_function_id IE.

TP12__S1_02 On receipt of a PORT CONTROL message containing the control_function_element IE FE204 (block_cmd), the IUT shall send a PORT CONTROL ACK message containing the same control_function_element IE.

5.2.3 Valid behaviour tests (V5NWKLE/CTRL/BV)

5.2.3.1 V5NWKLE/CTRL/BV/COM

5.2.3.1.1 V5NWKLE/CTRL/BV/COM/TRANS

Refer to EN 300 324-1 [1], table 62 and subclause L.2.5.3.2.

Initial state of the IUT: CTRL_COM_INIT, CTRL_PORT_INIT

Preamble: -
Postamble: -

TP1311S1_01 Refer to TP12__S1_01 in subclause 5.2.2.

TP1311SM_02 On receipt of a MDU-CTRL (request variant & interface ID) the IUT shall send a COMMON CONTROL message containing the control_function_id IE "request variant & interface ID".
(*)

On receipt of a COMMON CONTROL ACK message containing the control_function_id IE "request variant & interface ID" the IUT shall not repeat the original message.

TP1311SM_03 Check that the IUT is able to control messages in both directions at the same time:

Preamble:

On receipt of a COMMON CONTROL message containing the control_function_id IE "request variant & interface ID" the IUT shall send COMMON CONTROL ACK message.

On receipt of a MDU-CTRL (variant & interface ID) the IUT shall send a COMMON CONTROL message containing the control_function_id IE "variant & interface ID".

On receipt of a COMMON CONTROL message containing the control_function_id IE "variant & interface id", the IUT shall send a COMMON CONTROL ACK message containing the same control_function_id IE.

On receipt of a COMMON CONTROL ACK message containing the control_function_id IE "variant & interface ID", the IUT shall not repeat the original message.

5.2.3.1.2 V5NWKLE/CTRL/BV/COM/REST

Refer to EN 300 324-1 [1], table 62, annex C, and subclause L.2.7.

As the COM is tested separately (refer to subclause 5.2.3.1.1), the COMMON CONTROL ACK messages are not mentioned in the following TPs.

NOTE: This test group is only valid if PICS item M2 is set to "Yes" (see EN 300 324-2 [2]).

Initial state of the IUT: CTRL_COM_INIT, CTRL_PORT_INIT

Preamble: -
Postamble: sending of a COMMON CONTROL message containing the control_function_id IE "restart complete"

TP1312SM_01 On receipt of MDU_CTRL (restart_req) the IUT shall send a COMMON CONTROL message containing the control_function_id IE "restart req".
(*)

The IUT shall send a COMMON CONTROL message containing the control_function_id IE "restart complete".

TP1312SM_02 On receipt of a COMMON CONTROL message containing the control_function_id IE "restart req" the IUT shall send a COMMON CONTROL message containing the control_function_id IE "restart complete".

5.2.3.1.3 V5NWKLE/CTRL/BV/COM/REVV

Refer to EN 300 324-1 [1], tables 65 and 67, annex C, and subclause L.2.7.

As the COM is tested separately (refer to subclause 5.2.3.1.1), the COMMON CONTROL ACK messages are not mentioned in the following TPs.

Initial state of the IUT: CTRL_COM_INIT, CTRL_PORT_INIT

Preamble: CTRL_PSTN_LE20_10, CTRL_ISDNBA_LE20_10

Postamble: CTRL_PSTN_LE20_10, CTRL_ISDNBA_LE20_10

- TP1313S0_01 (note 1) Refer to TP1311SM_03 in subclause 5.2.3.1.1.
- TP1313S0_02 (note 1) On receipt of a COMMON CONTROL message containing the control_function_id IE "verify re-provisioning" and the current variant IE, the IUT shall send a COMMON CONTROL message containing the control_function_id IE "not ready for re-provisioning" .
- TP1313S0_03 (note 2) On receipt of a COMMON CONTROL message containing the control_function_id IE "verify re-provisioning" and an unknown variant IE, the IUT shall send a COMMON CONTROL message containing the control_function_id IE "not ready for re-provisioning", the current variant IE and the rejection_cause IE "unknown variant".
- TP1313S0_04 (note 2) On receipt of a COMMON CONTROL message containing the control_function_id IE "switch-over to new variant" and an unknown variant IE the IUT shall send a COMMON CONTROL message containing the control_function_id IE "cannot re-provision", the current variant IE and the rejection_cause IE "unknown variant".
- TP1313S0_05 (note 2) On receipt of a COMMON CONTROL message containing the control_function_id IE "cannot re-provision" the IUT shall send a COMMON CONTROL ACK message, but no further event shall appear on the V5 interface.
- TP1313SM_06 (*) (note 2) Reprovisioning invoked by IUT, affected ports already blocked:
- On receipt of data_set_available the IUT shall send a COMMON CONTROL message containing the control_function_id IE "switch over to new variant" and the new variant IE.
- On receipt of a COMMON CONTROL message containing the control_function_id IE "request variant & interface id" the IUT shall send a COMMON CONTROL message containing the control_function_id IE "variant and interface id" and the current variant- and interface_id IEs.
- On receipt of a COMMON CONTROL message containing the control_function_id IE "verify re-provisioning" and the new variant IE the IUT shall send a COMMON CONTROL message containing the control_function_id IE "ready for re-provisioning" and the new variant IE.
- LT1 sends a COMMON CONTROL message containing the control_function_ID IE "reprovisioning started" and the new variant IE.
- After the completion of the reprovisioning, the IUT shall send a PORT CONTROL message containing the control_function_element IE FE201 (unblock_req).
- On receipt of a COMMON CONTROL message containing the control_function_id IE "Request variant & interface ID" the IUT shall send a COMMON CONTROL message containing the control_function_id IE "variant & interface ID" and the new variant IE.

- TP1313SM_07
(*
(note 2)
- Reprovisioning invoked by IUT, affected ports unblocked:
- Preamble: Force IUT to state LE1 (affected ports unblocked, data set available).
- On receipt of a COMMON CONTROL message containing the control_function_id IE "request variant & interface id" the IUT shall send a COMMON CONTROL message containing the control_function_id IE "variant and interface id" and the current variant- and interface_id IEs.
- On receipt of a COMMON CONTROL message containing the control_function_id IE "verify re-provisioning" and the new variant IE the IUT shall send a COMMON CONTROL message containing the control_function_id IE "ready for re-provisioning" and the new variant IE.
- On receipt of a COMMON CONTROL message containing the control_function_id IE "switch-over to new variant" and the new variant IE the IUT shall send a COMMON CONTROL message containing the control_function_id IE "blocking started".
- On receipt of ports_blocked the IUT shall send a COMMON CONTROL message containing the control_function_id IE "switch-over to new variant" and the new variant IE.
- LT1 sends a COMMON CONTROL message containing the control_function_ID IE "reprovisioning started" and the new variant IE.
- After the completion of the reprovisioning the IUT shall send a PORT CONTROL message containing the control_function_element IE FE201 (unblock_req).
- On receipt of a COMMON CONTROL message containing the control_function_id IE "Request variant & interface ID" the IUT shall send a COMMON CONTROL message containing the control_function_id IE "variant & interface ID" and the new variant IE.
- TP1313SM_08
(*
(note 2)
- On receipt of data_set_available the IUT shall send a COMMON CONTROL message containing the control_function_id IE "switch over to new variant" and the new variant IE.
- On receipt of a COMMON CONTROL message containing the control_function_id IE "verify re-provisioning" and the current variant IE the IUT shall send a COMMON CONTROL message containing the control_function_id IE "not ready for re-provisioning", the new variant IE and the rejection_cause IE "unknown variant".
- TP1313SM_09
(*
(note 2)
- On receipt of data_set_available the IUT shall send a COMMON CONTROL message containing the control_function_id IE "switch over to new variant" and the new variant IE.
- On receipt of a COMMON CONTROL message containing the control_function_id IE "verify re-provisioning" and an unknown variant IE the IUT shall send a COMMON CONTROL message containing the control_function_id IE "not ready for re-provisioning", the new variant IE and the rejection_cause IE "unknown variant".
- TP1313SM_10
(*
(note 2)
- On receipt of data_set_available the IUT shall send a COMMON CONTROL message containing the control_function_id IE "switch over to new variant" and the new variant IE.
- On receipt of a COMMON CONTROL message containing the control_function_id IE "switch-over to new variant" and an unknown variant IE the IUT shall send a COMMON CONTROL message containing the control_function_id IE "cannot re-provision", the new variant IE and the rejection_cause IE "unknown variant".
- LT1 sends a COMMON CONTROL message containing the control_function_ID IE "reprovisioning started" and the new variant IE.
- After the completion of the reprovisioning the IUT shall send a PORT CONTROL message containing the control_function_element IE FE201 (unblock_req).
- On receipt of a COMMON CONTROL message containing the control_function_id IE "Request variant & interface ID" the IUT shall send a COMMON CONTROL message containing the control_function_id IE "variant & interface ID" and the new variant IE.

NOTE 1: TP1313S0_01 and TP1313S0_02 are only applicable if PICS item P5.2 is set to "Yes"
(see EN 300 324-2 [2]).

NOTE 2: TP1313S0_03 up to TP1313SM_10 are only applicable if PICS items P5.2 and P5.3 are set to "Yes"
(see EN 300 324-2 [2]).

5.2.3.2 V5NWKLE/CTRL/BV/PORT

5.2.3.2.1 V5NWKLE/CTRL/BV/PORT/TRANS

Refer to EN 300 324-1 [1], table 61 and subclause L.2.5.3.2.

Initial state of the IUT: CTRL_COM_INIT, CTRL_PORT_INIT

Preamble: -
Postamble: -

TP1321S1_01 Refer to TP12__S1_02 in subclause 5.2.2.

TP1321SM_02 On receipt of a FE203 (block_cmd) the IUT shall send a PORT CONTROL message
(* containing the control_function_element IE FE203 (block_cmd).

On receipt of a PORT CONTROL ACK containing the control_function_element IE FE203 (block_cmd) the IUT shall not repeat the original message.

TP1321SM_03 Check that the IUT is able to control messages in both directions at the same time:
(*

On receipt of a FE203 (block_cmd) the IUT shall send a PORT CONTROL message containing the control_function_element IE FE203 (block_cmd).

On receipt of a PORT CONTROL message containing the control_function_element IE FE204 (block_cmd), the IUT shall send a PORT CONTROL ACK message containing the same control_function_element IE.

On receipt of a PORT CONTROL ACK message containing the control_function_element IE FE203 (block_cmd), the IUT shall not repeat the original message.

5.2.3.2.2 V5NWKLE/CTRL/BV/PORT/PSTN

Refer to EN 300 324-1 [1], table 41 and subclause L.2.6.3.1.

As the Port control protocol is tested separately (refer to subclause 5.2.3.2.1), the PORT CONTROL ACK messages are not mentioned in the following TPs.

NOTE: This test group is only valid if PICS item M2 is set to "Yes" (see EN 300 324-2 [2]).

Initial state of the IUT: CTRL_COM_INIT, CTRL_PORT_INIT

Preamble: CTRL_PSTN_LE20_10
Postamble: CTRL_PSTN_LE20_10

TP1324S1001 On receipt of a MPH-BI (block_cmd) the IUT shall send a message containing the
(* control_function_element IE FE203 (block_cmd) and the IUT PSTN protocol FSM shall remain in PSTN_path_state LE6.

TP1324S1002 On receipt of a PORT CONTROL message containing the control_function_element IE FE204 (block_cmd) the IUT shall send a PORT CONTROL ACK message, but no further event shall appear on the V5 interface.

TP1324S1003 On receipt of a PORT CONTROL message containing the control_function_element IE FE205 (block_req) the IUT shall send a PORT CONTROL ACK message, but no further event shall appear on the V5 interface.

- TP1324S1104
(*) Preamble:
On receipt of a MPH-UBR (unblock_req) the IUT shall send a message containing the control_function_element IE FE201 (unblock_req).
- On receipt of a PORT CONTROL message containing the control_function_element IE FE205 (block_req) the IUT shall send a PORT CONTROL ACK message, but no further event shall appear on the V5 interface.
- TP1324SM_05
(*) Verify "Repeated Local Unblocking" procedure.
- Preamble:
On receipt of a MPH-UBR (unblock_req) the IUT shall send a message containing the control_function_element IE FE201 (unblock_req).
- On receipt of a MPH-UBR (unblock_req) the IUT shall repeat the message containing the control_function_element IE FE201 (unblock_req).
- On receipt of a message containing the control_function_element FE202 (unblock_ack) the IUT PSTN protocol FSM shall enter PSTN_path_state LE1 (Null).
- On receipt of a MPH-UBR (unblock_req) the IUT shall send a message containing the control_function_element IE FE201 (unblock_req) and the IUT PSTN protocol FSM shall remain in PSTN_path_state LE1.
- TP1324S1106
(*) Verify "Unacknowledged Local Unblocking" procedure.
- On receipt of a MPH-UBR (unblock_req) the IUT shall send a message containing the control_function_element IE FE201 (unblock_req).
- If LT1 sends no message containing the control_function_element IE FE202 (unblock_ack) the IUT PSTN protocol FSM shall remain in PSTN_path_state LE6 (Port blocked).
- TP1324SM_07
(*) Verify "Local Unblocking/Blocking" procedure.
- On receipt of a MPH-UBR (unblock_req) the IUT shall send a message containing the control_function_element IE FE201 (unblock_req).
- On receipt of a message containing the control_function_element IE FE202 (unblock_ack) the IUT PSTN protocol FSM shall enter PSTN_path_state LE1.
- On receipt of a MPH-BI (block_cmd) the IUT shall send a message containing the control_function_element IE FE203 (block_cmd) and the IUT PSTN protocol FSM shall enter PSTN_path_state LE6.
- TP1324SM_08
Verify "Remote Unblocking/Blocking" procedure.
- On receipt of a message containing the control_function_element IE FE202 (unblock_req) the IUT shall send a message containing the control_function_element IE FE201 (unblock_ack) and the IUT PSTN protocol FSM shall enter PSTN_path_state LE1
- On receipt of a message containing the control_function_element IE FE202 (unblock_req) the IUT PSTN protocol FSM shall remain in PSTN_path_state LE1
- On receipt of a message containing the control_function_element IE FE204 (block_cmd) the IUT PSTN protocol FSM shall enter PSTN_path_state LE6.
- TP1324SM_09
Verify "Blocking Request" procedure.
- Preamble with CTRL_PSTN_LE10_20
- On receipt of a message containing the control_function_element IE FE205 (block_req) the IUT shall send a message containing the control_function_element IE FE203 (block_cmd) and the IUT PSTN protocol FSM shall enter PSTN_path_state LE6.

TP1324SM_10 Verify "Rejected Unblocking" procedure.
 (*)
 On receipt of a MPH-UBR (unblock_req) the IUT shall send a message containing the control_function_element IE FE201 (unblock_req).

On receipt of a message containing the control_function_element IE FE204 (block_cmd) the IUT PSTN protocol FSM shall remain in PSTN_path_state LE6.

TP1324SM_11 Verify "Cancelled Unblocking" procedure.
 (*)
 On receipt of a MPH-UBR (unblock_req) the IUT shall send a message containing the control_function_element IE FE201 (unblock_req).

On receipt of a MPH-BI (block_cmd) the IUT shall send a message containing the control_function_element IE FE203 (block_cmd) and the IUT PSTN protocol FSM shall remain in PSTN_path_state LE6.

5.2.3.2.3 V5NWKLE/CTRL/BV/PORT/ISDNBA

Refer to EN 300 324-1 [1], table 36 and subclause L.2.6.

As the Port control protocol is tested separately (refer to subclause 5.2.3.2.1), the PORT CONTROL ACK messages are not mentioned in the following TPs.

NOTE: This test group is only valid if PICS item M1 is set to "Yes" (see EN 300 324-2 [2]).

Initial state of the IUT: CTRL_COM_INIT, CTRL_PORT_INIT

Preamble: CTRL_ISDNBA_LE20_10

Postamble: CTRL_ISDNBA_LE20_10

TP1325S1001 On receipt of a MPH-BI (block_cmd) the IUT shall send a message containing the control_function_element IE FE203 (block_cmd).
 (*)

TP1325S1002 On receipt of a PORT CONTROL message containing the control_function_element IE FE102 (activation_initiated_by_user) the IUT shall send a PORT CONTROL ACK message, but no further event shall appear on the V5 interface.

TP1325S1003 On receipt of a PORT CONTROL message containing the control_function_element IE FE103 (DS_activated) the IUT shall send a PORT CONTROL ACK message, but no further event shall appear on the V5 interface.

TP1325S1004 On receipt of a PORT CONTROL message containing the control_function_element IE FE104 (access_activated) the IUT shall send a PORT CONTROL ACK message, but no further event shall appear on the V5 interface.

TP1325S1005 On receipt of a PORT CONTROL message containing the control_function_element IE FE106 (access_deactivated) the IUT shall send a PORT CONTROL ACK message, but no further event shall appear on the V5 interface.

TP1325S1006 On receipt of a PORT CONTROL message containing the control_function_element IE FE204 (block_cmd) the IUT shall send a PORT CONTROL ACK message, but no further event shall appear on the V5 interface.

TP1325S1007 On receipt of a PORT CONTROL message containing the control_function_element IE FE205 (block_req) the IUT shall send a PORT CONTROL ACK message, but no further event shall appear on the V5 interface.

- TP1325S1108
(*)
Preamble:
On receipt of MPH-UBR (unblock_req) the IUT shall send a message containing the control_function_element IE FE201 (unblock_req) (IUT ISDN-BA port FSM enters state LE1.1).

On receipt of a PORT CONTROL message containing the control_function_element IE FE103 (DS_activated) the IUT shall send a PORT CONTROL ACK message, but no further event shall appear on the V5 interface.
- TP1325S1109
(*)
Preamble:
On receipt of MPH-UBR (unblock_req) the IUT shall send a message containing the control_function_element IE FE201 (unblock_req) (IUT ISDN-BA port FSM enters state LE1.1).

On receipt of a PORT CONTROL message containing the control_function_element IE FE106 (access_deactivated) the IUT shall send a PORT CONTROL ACK message, but no further event shall appear on the V5 interface.
- TP1325S1110
(*)
Preamble:
On receipt of MPH-UBR (unblock_req) the IUT shall send a message containing the control_function_element IE FE201 (unblock_req) (IUT ISDN-BA port FSM enters state LE1.1).

On receipt of a PORT CONTROL message containing the control_function_element IE FE205 (block_req) the IUT shall send a PORT CONTROL ACK message, but no further event shall appear on the V5 interface.
- TP1325SM_11
(*)
Verify "Repeated Local Unblocking" procedure.

Preamble:
On receipt of MPH-UBR (unblock_req) the IUT shall send a message containing the control_function_element IE FE201 (unblock_req) (IUT ISDN-BA port FSM enters state LE1.1).

On receipt of a MPH-UBR (unblock_req) the IUT shall send a message containing the control_function_element IE FE201 (unblock_req).

LT1 sends a message containing the control_function_element IE FE202 (unblock_ack) (IUT ISDN-BA port FSM enters state LE2.0).

On receipt of a MPH-UBR (unblock_req) the IUT shall send a message containing the control_function_element IE FE201 (unblock_req).
- TP1325S2012
Preamble: CTRL_ISDNBA_LE10_20.

On receipt of a PORT CONTROL message containing the control_function_element IE FE103 (DS_activated) the IUT shall send a PORT CONTROL ACK message, but no further event shall appear on the V5 interface.
- TP1325S2013
(*)
Preamble: CTRL_ISDNBA_LE10_20.

On receipt of a MPH_DR (deactivate_access_req) the IUT shall send a message containing the control_function_element FE105 (deactivate_access).
- TP1325S2114
Preamble: CTRL_ISDNBA_LE10_20 to enter the port operational state.

On simulating a "user initiated activation" the LT1 sends a message containing the control_function_element IE FE102 (activation initiated by user) (the IUT enters the ISDN-BA port FSM state LE2.1).

On receipt of a PORT CONTROL message containing the control_function_element IE FE102 (activation initiated by user) the IUT shall send a PORT CONTROL ACK message, but no further event shall appear on the V5 interface.

- TP1325S2215 Preamble: CTRL_ISDNBA_LE10_20 to enter the port operational state.
- On simulating a "user activation" the LT1 sends a message containing the control_function_element IE FE104 (access activated) (the IUT enters the ISDN-BA port FSM state LE2.2).
- On receipt of a PORT CONTROL message containing the control_function_element IE FE104 (access activated) the IUT shall send a PORT CONTROL ACK message, but no further event shall appear on the V5 interface.
- TP1325SM_16 (*) Verify "Local Unblocking/Blocking" procedure, access remains deactivated.
- On receipt of MPH-UBR (unlock_req) the IUT shall send a message containing the control_function_element IE FE201 (unlock_req) (IUT ISDN-BA port FSM enters state LE1.1).
- LT1 sends a message containing the control_function_element IE FE202 (unlock_ack) (IUT ISDN-BA port FSM enters state LE2.0) and a subsequent message containing the control_function_element IEs FE106 (access_deactivated).
- On receipt of a MPH-BI (block_cmd) the IUT shall send a message containing the control_function_element IE FE203 (block_cmd) (IUT ISDN-BA port FSM enters state LE1.0).
- TP1325S2117 (*) Verify "Local Blocking" procedure, access activation initiated.
- Preamble: CTRL_ISDNBA_LE10_20 to enter the port operational state.
- On simulating a "user initiated activation" the LT1 sends a message containing the control_function_element IE FE102 (activation initiated by user) (the IUT enters the ISDN-BA port FSM state LE2.1).
- On receipt of a MPH-BI (block_cmd) the IUT shall send a message containing the control_function_element IE FE203 (block_cmd) (IUT ISDN-BA port FSM enters state LE1.0).
- TP1325S2218 (*) Verify "Local Blocking" procedure, access activated.
- Preamble: CTRL_ISDNBA_LE10_20 to enter the port operational state.
- On simulating a "user activation" the LT1 sends a message containing the control_function_element IE FE104 (access activated) (the IUT enters the ISDN-BA port FSM state LE2.2.)
- On receipt of a MPH-BI (block_cmd) the IUT shall send a message containing the control_function_element IE FE203 (block_cmd) (IUT ISDN-BA port FSM enters state LE1.0).
- TP1325SM_19 Verify "Remote Unblocking/Blocking" procedure, access remains deactivated.
- On receipt of a message containing the control_function_element IE FE202 (unlock_req) the IUT shall send a message containing the control_function_element IE FE201 (unlock_ack) (IUT ISDN-BA port FSM enters state LE2.0).
- On receipt of a sequence of messages containing the control_function_element IEs FE202 (unlock_req), FE204 (block_cmd) (IUT ISDN-BA port FSM enters state LE1.0) and FE202 (unlock_req) the IUT shall send a message containing the control_function_element IE FE201 (unlock_ack) (IUT ISDN-BA port FSM enters state LE2.0).

- TP1325S2120 Verify " Remote Unblocking/Blocking" procedure, access activation initiated.
- Preamble: CTRL_ISDNBA_LE10_20 to enter the port operational state.
- On simulating a "user initiated activation" the LT1 sends a message containing the control_function_element IE FE102 (activation initiated by user) (the IUT enters the ISDN-BA port FSM state LE2.1).
- On receipt of a message containing the control_function_element IE FE202 (unlock_req) the IUT shall send a message containing the control_function_element IE FE201 (unlock_ack) (IUT ISDN-BA port FSM remains in state LE2.1).
- On receipt of a message containing the control_function_element IEs FE204 (block_cmd) (IUT ISDN-BA port FSM enters state LE1.0) and FE202 (unlock_req) the IUT shall send a message containing the control_function_element IE FE201 (unlock_ack) (IUT ISDN-BA port FSM enters state LE2.0).
- TP1325S2121 Verify " Remote Unblocking/Blocking" procedure, access activated.
- Preamble: CTRL_ISDNBA_LE10_20 to enter the port operational state.
- On simulating a "user activation" the LT1 sends a message containing the control_function_element IE FE104 (access activated) (the IUT enters the ISDN-BA port FSM state LE2.2).
- On receipt of a message containing the control_function_element IE FE202 (unlock_req) the IUT shall send a message containing the control_function_element IE FE201 (unlock_ack) (IUT ISDN-BA port FSM remains in state LE2.2).
- On receipt of a message containing the control_function_element IEs FE204 (block_cmd) (IUT ISDN-BA port FSM enters state LE1.0) and FE202 (unlock_req) the IUT shall send a message containing the control_function_element IE FE201 (unlock_ack) (IUT ISDN-BA port FSM enters state LE2.0).
- TP1325SM_22 Verify "Blocking Request" procedure, access remains deactivated.
- Preamble with CTRL_ISDNBA_LE10_20.
- On receipt of a message containing the control_function_element IE FE205 (block_req) the IUT shall send a message containing the control_function_element IE FE203 (block_cmd) (IUT ISDN-BA port FSM enters state LE1.0).
- TP1325SM_23 Verify "Rejected Unblocking" procedure, access remains deactivated.
(*)
- On receipt of MPH-UBR (unlock_req) the IUT shall send a message containing the control_function_element IE FE201 (unlock_req) (IUT ISDN-BA port FSM enters state LE1.1).
- On receipt of a sequence of messages containing the control_function_element IEs FE204 (block_cmd) (IUT ISDN-BA port FSM enters state LE1.0) and FE202 (unlock_req) the IUT shall send a message containing the control_function_element IE FE201 (unlock_ack) (IUT ISDN-BA port FSM enters state LE2.0).
- TP1325SM_24 Verify "Cancelled Unblocking" procedure, access remains deactivated.
(*)
- On receipt of MPH-UBR (unlock_req) the IUT shall send a message containing the control_function_element IE FE201 (unlock_req) (IUT ISDN-BA port FSM enters state LE1.1).
- On receipt of a MPH-BI (block_cmd) the IUT shall send a message containing the control_function_element IE FE203 (block_cmd) (IUT ISDN-BA port FSM enters state LE1.0).

- TP1325SM_25
(*)
- Verify "rejected activation for terminating call" procedure.
- Preamble with CTRL_ISDNBA_LE10_20 to enter the port operational state.
- On receipt of a terminating call attempt (MPH-AR), the IUT shall send a message containing the control_function_element IE FE101 (activate access) (IUT ISDN-BA port FSM enters state LE2.1).
- The LT1 sends a message containing the control_function_element IE FE106 (access deactivated) (IUT ISDN-BA port FSM enters state LE2.0).
- TP1325SM_26
(*)
- Verify "activation for terminating call" procedure.
- Preamble with CTRL_ISDNBA_LE10_20 to enter the port operational state.
- On receipt of a terminating call attempt (MPH-AR), the IUT shall send a message containing the control_function_element IE FE101 (activate access) (IUT ISDN-BA port FSM enters state LE2.1).
- On receipt of MPH-DR (deactivate access) the IUT shall send a message containing the control_function_element IE FE105 (deactivate access) (IUT ISDN-BA port FSM enters state LE2.0).
- LT1 sends a message containing the control_function_element IE FE106 (access deactivated) (IUT ISDN-BA port FSM enters state LE2.0).
- TP1325SM_27
- Verify "activation for originating call" procedure.
- Preamble with CTRL_ISDNBA_LE10_20 to enter the port operational state.
- On simulating a "user initiated activation" the LT1 sends a message containing the control_function_element IE FE102 (activation initiated by user) (the IUT enters the ISDN-BA port FSM state LE2.1).
- On simulating a DS activation, the LT1 sends a message containing the control_function_element IE FE103 (DS activated) (the IUT remains in the ISDN-BA port FSM state LE2.1).
- On simulating an activated access, the LT1 sends a message containing the control_function_element IE FE104 (access activated) (the IUT enters the ISDN-BA port FSM state LE2.2).
- The LT1 waits until the network (IUT) deactivate the access.
- On receipt of MPH-DR (deactivation request) the IUT shall send a message containing the control_function_element IE FE105 (deactivate access)(IUT ISDN-BA port FSM enters state LE2.0).
- LT1 sends a message containing the control_function_element IE FE106 (access deactivated) (IUT ISDN-BA port FSM remains in state LE2.0).

5.2.4 Inopportune behaviour tests (V5NWKLE/CTRL/BO)

5.2.4.1 V5NWKLE/CTRL/BO/COM

5.2.4.1.1 V5NWKLE/CTRL/BO/COM/TRANS

Refer to EN 300 324-1 [1], table 62.

Initial state of the IUT: CTRL_COM_INIT, CTRL_PORT_INIT

Preamble: -
Postamble: -

TP1411S1_01 On receipt of a COMMON CONTROL ACK message the IUT shall ignore the message.

5.2.4.1.2 V5NWKLE/CTRL/BO/COM/REVV

Refer to EN 300 324-1 [1], table 67.

NOTE: This test group is only valid if PICS item P5.2 is set to "Yes" (see EN 300 324-2 [2]).

Initial state of the IUT: CTRL_COM_INIT, CTRL_PORT_INIT

Preamble: CTRL_PSTN_LE20_10, CTRL_ISDNBA_LE20_10
Postamble: -

TP1413S0_01 On receipt of a COMMON CONTROL message containing the control_function_id IE "switch-over to new variant" and the current variant IE the IUT shall send a COMMON CONTROL ACK message, but no further event shall appear on the V5 interface.

TP1413S0_02 On receipt of a COMMON CONTROL message containing the control_function_id IE "reprovisioning started" the IUT shall send a COMMON CONTROL ACK message, but no further event shall appear on the V5 interface.

5.2.4.2 V5NWKLE/CTRL/BO/PORT

5.2.4.2.1 V5NWKLE/CTRL/BO/PORT/TRANS

Refer to EN 300 324-1 [1], table 61.

Initial state of the IUT: CTRL_COM_INIT, CTRL_PORT_INIT

Preamble: CTRL_PSTN_LE20_10, CTRL_ISDNBA_LE20_10
Postamble: -

TP1421S1_01 On receipt of a PORT CONTROL ACK message the IUT shall ignore the message.

5.2.4.2.2 V5NWKLE/CTRL/BO/PORT/ISDNBA

Refer to EN 300 324-1 [1], table 36.

NOTE: This test group is only valid if PICS item M1 is set to "Yes" (see EN 300 324-2 [2]).

Initial state of the IUT: CTRL_COM_INIT, CTRL_PORT_INIT

Preamble: CTRL_ISDNBA_LE20_10

Postamble: -

TP1425S1001 (note 1) On receipt of a PORT CONTROL message containing the control_function_element IE FE206 (grading) the IUT shall send a PORT CONTROL ACK message, but no further event shall appear on the V5 interface.

TP1425S1102 (note 1) (*) Preamble: On receipt of MPH-UBR (unblock_req) the IUT shall send a message containing the control_function_element IE FE201 (unblock_req) (IUT ISDN-BA port FSM enters state LE1.1).

On receipt of a PORT CONTROL message containing the control_function_element IE FE206 (grading) the IUT shall send a PORT CONTROL ACK message, but no further event shall appear on the V5 interface.

TP1425S2003 (note 1) Preamble: CTRL_ISDNBA_LE10_20.

On receipt of a PORT CONTROL message containing the control_function_element IE FE206 (grading) the IUT shall send a PORT CONTROL ACK message, but no further event shall appear on the V5 interface.

TP1425S2104 (note 1) Preamble: CTRL_ISDNBA_LE10_20 to enter the port operational state.

On simulating a "user initiated activation" the LT1 sends a message containing the control_function_element IE FE102 (activation initiated by user) (the IUT enters the ISDN-BA port FSM state LE2.1).

On receipt of a PORT CONTROL message containing the control_function_element IE FE206 (grading) the IUT shall send a PORT CONTROL ACK message, but no further event shall appear on the V5 interface.

TP1425S2205 Preamble: CTRL_ISDNBA_LE10_20 to enter the port operational state.

On simulating a "user activation" the LT1 sends a message containing the control_function_element IE FE104 (access activated) (the IUT enters the ISDN-BA port FSM state LE2.2).

On receipt of a PORT CONTROL message containing the control_function_element IE FE102 (activation initiated by user) the IUT shall send a PORT CONTROL ACK message, but no further event shall appear on the V5 interface.

TP1425S2206 Preamble: CTRL_ISDNBA_LE10_20 to enter the port operational state.

On simulating a "user activation" the LT1 sends a message containing the control_function_element IE FE104 (access activated) (the IUT enters the ISDN-BA port FSM state LE2.2).

On receipt of a PORT CONTROL message containing the control_function_element IE FE103 (DS activated) the IUT shall send a PORT CONTROL ACK message, but no further event shall appear on the V5 interface.

NOTE 1: TP1425S1001, TP1425S1102, TP1425S2003 and TP1425S2104 are only applicable if PICS item U5.1 is set to "Yes" (see EN 300 324-2 [2]).

5.2.5 Invalid behaviour tests (V5NWKLE/CTRL/BI)

Refer to EN 300 324-1 [1], subclause 14.4.4.2.

5.2.5.1 V5NWKLE/CTRL/BI/COM

5.2.5.1.1 V5NWKLE/CTRL/BI/COM/TRANS

Initial state of the IUT: CTRL_COM_INIT

Preamble: CTRL_PSTN_LE20_10, CTRL_ISDNBA_LE20_10

Postamble: -

- | | |
|-------------|--|
| TP1511S1_01 | Check that the IUT discards messages having less than 4 octets. |
| TP1511S1_02 | (protocol discriminator error)
Check that the IUT discards a message containing an unspecified protocol_discriminator IE. |
| TP1511S1_03 | (L3addr error)
Check that the IUT discards a message containing an unspecified L3addr IE. |
| TP1511S1_04 | (message type error)
Check that the IUT discards a message containing an unspecified message_type IE. |
| TP1511S1_05 | (repeated optional IE)
Check that the IUT sends an ACK message after receipt of a message containing the control_function_id IE "Request variant & interface id" and two repeated interface_id IEs. |
| TP1511S1_06 | (repeated mandatory IE)
Check that the IUT discards a message containing two repeated control_function_id IE. |
| TP1511S1_07 | (mandatory IE missing)
Check that the IUT discards a message containing no control_function_id IE. |
| TP1511S1_08 | (unrecognized IE)
Check that the IUT sends an ACK message after receipt of a message containing the control_function_id IE "variant & interface id", a variant IE, interface_id IE, and an additional unspecified IE. |
| TP1511S1_09 | (content error of mandatory IE)
Check that the IUT discards a message containing an incorrect control_function_id IE. |
| TP1511S1_10 | Check that the IUT discards a message containing the control_function_id "variant & interface id", a variant IE, and an interface_id IE with an incorrect length. |
| TP1511S1_12 | Check that the IUT discards a message containing the control_function_id "variant & interface id", a variant IE, and no interface_id IE. |

5.2.5.2 V5NWKLE/CTRL/BI/PORT

5.2.5.2.1 V5NWKLE/CTRL/BI/PORT/TRANS

NOTE: This test group is only valid if PICS item M1 is set to "Yes" (see EN 300 324-2 [2]).

Initial state of the IUT: CTRL_PORT_INIT

Preamble: CTRL_PSTN_LE20_10, CTRL_ISDNBA_LE20_10

Postamble: -

- | | |
|-------------------------|---|
| TP1521S1_01 | Check that the IUT discards messages having less than 4 octets. |
| TP1521S1_02 | (protocol discriminator error)
Check that the IUT discards a message containing an unspecified protocol_discriminator IE. |
| TP1521S1_03 | (L3addr error)
Check that the IUT discards a message containing an unprovisioned L3addr IE. |
| TP1521S1_04 | (message type error)
Check that the IUT discards a message containing an unspecified message_type IE. |
| TP1521S1_05
(note 1) | (repeated optional IE)
Check that the IUT sends an ACK message after receipt of a message containing the control_function_element IE FE205 and two repeated performance_grading IEs. |
| TP1521S1_06 | (repeated mandatory IE)
Check that the IUT discards a message containing two repeated control_function_element IEs. |
| TP1521S1_07 | (mandatory IE missing)
Check that the IUT discards a message containing no control_function_element IE. |
| TP1521S1_08 | (unrecognized IE)
Check that the IUT sends an ACK message after receipt of a message containing the control_function_element IE FE205 and an additional unspecified optional IE. |
| TP1521S1_09 | (content error of mandatory IE)
Check that the IUT discards a message containing an incorrect control_function_element IE. |
| TP1521S1_10
(note 1) | Check that the IUT discards a message containing the control_function_element IE FE206 and two repeated performance_grading IEs. |
| TP1521S1_11
(note 1) | Check that the IUT discards a message containing the control_function_element IE FE206 and no performance_grading IE. |
| TP1521S1_12
(note 1) | Check that the IUT discards a message containing the control_function_element IE FE206 and an incorrect performance_grading IE. |

NOTE 1: TP1521S1_05, TP1521S1_10, TP1521S1_11 and TP1521S1_12 are only applicable if PICS item U5.1 is set to "Yes" (see EN 300 324-2 [2]).

5.2.6 Timer expiry and counter mismatch tests (V5NWKLE/CTRL/TI)

5.2.6.1 V5NWKLE/CTRL/TI/COM

5.2.6.1.1 V5NWKLE/CTRL/TI/COM/TRANS

Refer to EN 300 324-1 [1], table 62 and subclause L.2.5.3.2.

Initial state of the IUT: CTRL_COM_INIT

Preamble: CTRL_PSTN_LE20_10, CTRL_ISDNBA_LE20_10

Postamble: -

TP1611S2_01 Preamble:
On receipt of a COMMON CONTROL message containing the control_function_id IE "request variant & interface ID" the IUT shall send a COMMON CONTROL ACK message containing the same control_function_id IE.

On receipt of a MDU-CTRL (variant & interface ID) the IUT shall send a COMMON CONTROL message containing the control_function_id IE "request variant & interface ID".

On time-out of timer T02 the IUT shall repeat sending the COMMON CONTROL message N02 times.

TP1611S2_02 Preamble:
On receipt of a COMMON CONTROL message containing the control_function_id IE "request variant & interface ID" the IUT shall send a COMMON CONTROL ACK message containing the same control_function_id IE.

On receipt of a MDU-CTRL (variant & interface ID) the IUT shall send a COMMON CONTROL message containing the control_function_id IE "variant & interface ID".

On receipt of a COMMON CONTROL ACK message containing not the same control_function_id IE the IUT shall ignore the message.

On time-out of timer T02 the IUT shall repeat sending the COMMON CONTROL message.

5.2.6.2 V5NWKLE/CTRL/TI/PORT

5.2.6.2.1 V5NWKLE/CTRL/TI/PORT/TRANS

Refer to EN 300 324-1 [1], table 61 and subclause L.2.5.3.2.

Initial state of the IUT: CTRL_COM_INIT, CTRL_PORT_INIT

Preamble: CTRL_PSTN_LE20_10, CTRL_ISDNBA_LE20_10

Postamble: -

TP1621S2_01 Preamble:
On receipt of a PORT CONTROL message containing the control_function_element IE FE202 (unblock_req) the IUT shall send a PORT CONTROL ACK message containing the same control_function_element IE.

On receipt of a FE201 (unblock_ack) the IUT shall send a PORT CONTROL message containing the control_function_element IE FE201 (unblock_ack).

On time-out of timer T01 the IUT shall repeat sending the PORT CONTROL message N01 times.

- TP1621S2_02 Preamble:
 On receipt of a PORT CONTROL message containing the control_function_element IE FE202 (unblock_req) the IUT shall send a PORT CONTROL ACK message containing the same control_function_element IE.
- On receipt of a FE201 (unblock_ack) the IUT shall send a PORT CONTROL message containing the control_function_element IE FE201 (unblock_ack).
- On receipt of a PORT CONTROL ACK message containing not the same control_function_element IE the IUT shall ignore the message.
- On time-out of timer T01 the IUT shall repeat sending the PORT CONTROL message N01 times.

5.3 PSTN Protocol

The preamble before any test always begins with PSTN port blocking and unblocking to be sure that delayed or outstanding messages are discarded.

NOTE: This test group is only valid if PICS item M2 is set to "Yes" (see EN 300 324-2 [2]).

5.3.1 Basic interconnection tests (V5NWKLE/PSTN/IT)

Refer to EN 300 324-1 [1], table 30 and subclause L.2.4.

All messages sent by LT1 have to be valid PSTN messages.

Initial state of the IUT: CTRL_COM_INIT, CTRL_PORT_INIT, PSTN_INIT

Preamble: PSTN_LEx_6 & PSTN_LE6_1

Postamble: PSTN_LEx_6

- TP21__S1_01 On receipt of a DISCONNECT message the IUT shall send a DISCONNECT COMPLETE message.

5.3.2 Capability tests (V5NWKLE/PSTN/CA)

Refer to EN 300 324-1 [1], table 30 and subclause L.2.4.

All messages sent by LT1 have to be valid PSTN messages.

Initial state of the IUT: CTRL_COM_INIT, CTRL_PORT_INIT, PSTN_INIT

Preamble: PSTN_LEx_6 & PSTN_LE6_1

Postamble: PSTN_LEx_6

- TP22__SM_01 On receipt of a terminating call request(FE-establish_request) the IUT shall send an
 (*) ESTABLISH message.
- TP22__SM_02 On receipt of an ESTABLISH message the IUT shall send an ESTABLISH ACK message.
- On receipt of a DISCONNECT message the IUT shall send a DISCONNECT COMPLETE message.

5.3.3 Valid behaviour tests (V5NWKLE/PSTN/BV)

Refer to EN 300 324-1 [1], table 30 and subclause L.2.4.

All messages sent by LT1 have to be valid PSTN messages.

5.3.3.1 V5NWKLE/PSTN/BV/0

Initial state of the IUT: CTRL_COM_INIT, CTRL_PORT_INIT, PSTN_INIT

Preamble: PSTN_LEx_6 & PSTN_LE6_1 & PSTN_LE1_0

Postamble: PSTN_LE0_1 & PSTN_LEx_6

- TP23__S0_01 On receipt of a PORT CONTROL message containing the control_function_element IE FE204 (block_cmd) (the PSTN protocol receives MDU-CTRL (port_blocked) the IUT shall enter the new PSTN_path_state LE6 (Port blocked).
- TP23__S0_02 On receipt of a PORT CONTROL message containing the control_function_element IE FE202 (unblock_req) (the PSTN protocol receives MDU-CTRL port_unblocked) the IUT shall remain in the PSTN_path_state LE0 (Out of Service).
- TP23__S0_03 On receipt of a DISCONNECT COMPLETE message the IUT ignore the message and remain in the PSTN_path_state LE0 (Out of Service).

5.3.3.2 V5NWKLE/PSTN/BV/1

Initial state of the IUT: CTRL_COM_INIT, CTRL_PORT_INIT, PSTN_INIT

Preamble: PSTN_LEx_6 & PSTN_LE6_1

Postamble: PSTN_LEx_6

- TP23__S1_01 On receipt of a DISCONNECT message the IUT shall send a DISCONNECT COMPLETE message and remain in the PSTN_path_state LE1 (Null).
- TP23__S1_02 On receipt of a terminating call request (FE-establish_request) the IUT shall send the message ESTABLISH and enter the new PSTN_path_state LE2 (Path initiated by LE).
(*)
- TP23__S1_03 On receipt of the ESTABLISH message the IUT shall send the message ESTABLISH ACK and enter the new PSTN_path_state LE4 (Path active).
- TP23__S1_04 Refer to TP1324SM_08 in subclause 5.2.3.2.1.
- TP23__S1_05 On receipt of a COMMON CONTROL message containing the control_function_id IE "restart req" (the PSTN protocol receives MDU-CTRL restart_request) the IUT shall send a DISCONNECT COMPLETE message and a COMMON CONTROL message containing the control_function_id IE "restart complete". The IUT shall enter PSTN_path_state LE0 (Out of Service).
- On receipt of a COMMON CONTROL message containing the control_function_id IE "restart complete" (the PSTN protocol receives MDU-CTRL restart_complete) the IUT shall enter PSTN_path_state LE1 (Null).
- TP23__S1_06 On receipt of a PORT CONTROL message containing the control_function_element IE FE202 (unblock_req) (the PSTN protocol receives MDU-CTRL port_unblocked) the IUT shall remain in the PSTN_path_state LE1 (Null).

5.3.3.3 V5NWKLE/PSTN/BV/2

Initial state of the IUT: CTRL_COM_INIT, CTRL_PORT_INIT, PSTN_INIT

Preamble: PSTN_LEx_6 & PSTN_LE6_1 & PSTN_LE1_2

Postamble: PSTN_LEx_6

- TP23__S2_01 (*) On receipt of an ESTABLISH message the IUT shall send an ESTABLISH ACK message (if originating calls have priority) and enter the new PSTN_path_state LE4 (Path active).
The IUT shall stop timer T1 (IUT shall not repeat the ESTABLISH message).
For simulating the path establishment for a normal call, the ESTABLISH message shall not contain the line_information IE.
- TP23__S2_02 (*) On receipt of an ESTABLISH message the IUT shall ignore the message (send no ESTABLISH ACK message) and remain in the PSTN_path_state LE2, if terminating calls have priority.
For simulating the path establishment for a normal call, the ESTABLISH message shall not contain the line_information IE.
- TP23__S2_03 (*) On receipt of a DISCONNECT message the IUT shall send a DISCONNECT COMPLETE message and enter the new PSTN_path_state LE1 (Null).
The IUT shall stop timer T1 (IUT shall not repeat the ESTABLISH message).
- TP23__S2_04 (*) On receipt of a DISCONNECT COMPLETE message the IUT shall enter the new PSTN_path_state LE1 (Null).
The IUT shall stop timer T1 (IUT shall not repeat the ESTABLISH message).
- TP23__S2_05 (*) On receipt of an ESTABLISH ACK message the IUT shall enter the new PSTN_path_state LE4 (Path active).
The IUT shall stop timer T1 (IUT shall not repeat the ESTABLISH message).
- TP23__S2_06 (*) On receipt of a PORT CONTROL message containing the control_function_element IE FE204 (block_cmd) (the PSTN protocol receives MDU-CTRL port_blocked) the IUT shall send a DISCONNECT COMPLETE message and enter the new PSTN_path_state LE6 (Port blocked).
The IUT shall stop timer T1 (IUT shall not repeat the ESTABLISH message).
- TP23__S2_07 (*) On receipt of a COMMON CONTROL message containing the control_function_id IE "restart req" (the PSTN protocol receives MDU-CTRL restart_request) the IUT shall send a DISCONNECT COMPLETE message and a COMMON CONTROL message containing the control_function_id IE "restart complete". The IUT shall enter PSTN_path_state LE0 (Out of Service).
The IUT shall stop timer T1 (IUT shall not repeat the ESTABLISH message).
On receipt of a COMMON CONTROL message containing the control_function_id IE "restart complete" (the PSTN protocol receives MDU-CTRL restart_complete) the IUT shall enter PSTN_path_state LE1 (Null).
- TP23__S2_08 On receipt of a PORT CONTROL message containing the control_function_element IE FE202 (unblock_req) (the PSTN protocol receives MDU-CTRL port_unblocked) the IUT shall remain in the PSTN_path_state LE2 (Path initiated by LE).
- TP23__S2_09 (*) On receipt of an ESTABLISH message containing a line_information IE the IUT shall send a DISCONNECT COMPLETE and enter the new PSTN_path_state LE1 (Null).
(note)

NOTE: TP23__S2_09 is only applicable if PICS item U1.13 is set to "Yes" (see EN 300 324-2 [2]).

5.3.3.4 V5NWKLE/PSTN/BV/4

Initial state of the IUT: CTRL_COM_INIT, CTRL_PORT_INIT, PSTN_INIT

Preamble: PSTN_LEx_6 & PSTN_LE6_1 & PSTN_LE1_3_4

Postamble: PSTN_LEx_6

- TP23__S4_01 Verify that the IUT is able to acknowledge multiple SIGNAL messages.
- On receipt of a SIGNAL message and time-out of Tr the IUT shall send a SIGNAL ACK message and shall not restart timer Tr (IUT shall not send additional SIGNAL ACK messages).
- On receipt of two subsequent SIGNAL messages and time-out of Tr the IUT shall send a SIGNAL ACK message and remain in the PSTN_path_state LE4 (Path active). The IUT shall not restart timer Tr (IUT shall not send additional SIGNAL_ACK messages).
- TP23__S4_02 Verify that the IUT is able to handle multiple SIGNAL ACK messages.
- On receipt of a SIGNAL ACK message containing the correct sequence number IE after sending a SIGNAL message the IUT shall stop timer Tt (IUT shall not send a DISCONNECT message).
- On receipt of a SIGNAL ACK message containing the correct sequence number IE after sending two SIGNAL messages the IUT shall stop timer Tt (IUT shall not send a DISCONNECT message).
- On receipt of a SIGNAL ACK message acknowledging only one SIGNAL message after sending two SIGNAL messages the IUT shall restart Timer Tt.
- On receipt of a SIGNAL ACK message acknowledging the last outstanding SIGNAL message the IUT shall remain in the PSTN_path_state LE4 (Path active).
- The IUT shall stop timer Tt (IUT shall not send a DISCONNECT message).
- TP23__S4_03 On receipt of a SIGNAL message and a subsequent DISCONNECT message the IUT shall send a DISCONNECT COMPLETE message and enter the PSTN_path_state LE1 (Null).
- The IUT shall stop timer Tr (IUT shall not send additional SIGNAL ACK messages).
- TP23__S4_04 On receipt of a SIGNAL message and a subsequent DISCONNECT COMPLETE message the IUT shall enter the PSTN_path_state LE1 (Null).
- The IUT shall stop timer Tr (IUT shall not send additional SIGNAL ACK messages).
- TP23__S4_05 On receipt of a SIGNAL message and a subsequent PORT CONTROL message containing the control_function_element IE FE204 (block_cmd) (the PSTN protocol receives MDU-CTRL port_blocked) the IUT shall send a DISCONNECT COMPLETE message and enter the new PSTN_path_state LE6 (Port blocked).
- The IUT shall stop timer Tr (IUT shall not send additional SIGNAL ACK messages).
- TP23__S4_06 On receipt of a SIGNAL message and a subsequent COMMON CONTROL message containing the control_function_id IE "restart req" (the PSTN protocol receives MDU-CTRL restart_request) the IUT shall send a DISCONNECT COMPLETE message and a COMMON CONTROL message containing the control_function_id IE "restart complete". The IUT shall enter PSTN_path_state LE0 (Out of Service).
- The IUT shall stop timer Tr (IUT shall not send additional SIGNAL ACK messages).
- On receipt of a COMMON CONTROL message containing the control_function_id IE "restart complete" (the PSTN protocol receives MDU-CTRL restart_complete) the IUT shall enter PSTN_path_state LE1 (Null).

TP23__S4_07 On receipt of a PORT CONTROL message containing the control_function_element IE FE202 (unlock_req) (the PSTN protocol receives MDU-CTRL port_unblocked) the IUT shall remain in the PSTN_path_state LE4 (Path active).

5.3.3.5 V5NWKLE/PSTN/BV/5

Initial state of the IUT: CTRL_COM_INIT, CTRL_PORT_INIT, PSTN_INIT

Preamble: PSTN_LEx_6 & PSTN_LE6_1 & PSTN_LE1_3_4 & PSTN_LE4_5

Postamble: PSTN_LEx_6

- TP23__S5_01 On receipt of a DISCONNECT COMPLETE message the IUT shall enter the new PSTN_path_state LE1 (Null).

The IUT shall stop timer T3 (IUT shall not send additional DISCONNECT messages).
- TP23__S5_02 On receipt of a DISCONNECT message the IUT shall enter the new PSTN_path_state LE1 (Null).

The IUT shall stop timer T3 (IUT shall not send additional DISCONNECT messages).
- TP23__S5_03 On receipt of a PORT CONTROL message containing the control_function_element IE FE204 (block_cmd) (the PSTN protocol receives MDU-CTRL port_blocked) the IUT shall send a DISCONNECT COMPLETE message and enter the new PSTN_path_state LE6 (Port blocked).

The IUT shall stop timer T3 (IUT shall not send additional DISCONNECT messages).
- TP23__S5_04 On receipt of a COMMON CONTROL message containing the control_function_id IE "restart req" (the PSTN protocol receives MDU-CTRL restart_request) the IUT shall send a DISCONNECT COMPLETE message and a COMMON CONTROL message containing the control_function_id IE "restart complete". The IUT shall enter PSTN_path_state LE0 (Out of Service).

The IUT shall stop timer T3 (IUT shall not send additional DISCONNECT messages).

On receipt of a COMMON CONTROL message containing the control_function_id IE "restart complete" (the PSTN protocol receives MDU-CTRL restart_complete) the IUT shall enter PSTN_path_state LE1 (Null).
- TP23__S5_05 On receipt of an ESTABLISH message the IUT shall ignore the message and remain in the PSTN_path_state LE5 (Path Disconnect Request).
- TP23__S5_06 On receipt of an ESTABLISH ACK message the IUT shall ignore the message and remain in the PSTN_path_state LE5 (Path Disconnect Request).
- TP23__S5_07 On receipt of a SIGNAL message the IUT shall ignore the message and remain in the PSTN_path_state LE5 (Path Disconnect Request).
- TP23__S5_08 On receipt of a SIGNAL ACK message the IUT shall ignore the message and remain in the PSTN_path_state LE5 (Path Disconnect Request).
- TP23__S5_09 On receipt of a STATUS message the IUT shall ignore the message and remain in the PSTN_path_state LE5 (Path Disconnect Request).
- TP23__S5_10 On receipt of a PORT CONTROL message containing the control_function_element IE FE202 (unlock_req) (the PSTN protocol receives MDU-CTRL port_unblocked) the IUT shall remain in the PSTN_path_state LE5 (Path Disconnect Request).

5.3.3.6 V5NWKLE/PSTN/BV/6

Initial state of the IUT: CTRL_COM_INIT, CTRL_PORT_INIT, PSTN_INIT

Preamble: PSTN_LEx_6

Postamble: PSTN_LEx_6

TP23__S6_01 Refer to TP1324SM_08 in subclause 5.2.3.2.1.

TP23__S6_02 On receipt of a COMMON CONTROL message containing the control_function_id IE "restart req" (the PSTN protocol receives MDU-CTRL restart_request) the IUT shall send a COMMON CONTROL message containing the control_function_id IE "restart complete".

On receipt of a COMMON CONTROL message containing the control_function_id IE "restart complete" (the PSTN protocol receives MDU-CTRL restart_complete) the IUT shall remain in the PSTN_path_state LE6 (Port blocked).

TP23__S6_03 On receipt of a PORT CONTROL message containing the control_function_element IE FE204 (block_cmd) (the PSTN protocol receives MDU-CTRL port_blocked) the IUT shall remain in the PSTN_path_state LE6 (Port blocked).

TP23__S6_04 On receipt of a DISCONNECT COMPLETE message the IUT ignore the message and remain in the PSTN_path_state LE6 (Port blocked).

5.3.4 Inopportune behaviour tests (V5NWKLE/PSTN/BO)

Refer to EN 300 324-1 [1], table 27 and 30, and subclause L.2.4.

All messages sent by LT1 and IUT have to be valid PSTN messages.

5.3.4.1 V5NWKLE/PSTN/BO/0

Initial state of the IUT: CTRL_COM_INIT, CTRL_PORT_INIT, PSTN_INIT

Preamble: PSTN_LEx_6 & PSTN_LE6_1 & PSTN_LE1_0

Postamble: PSTN_LE0_1 & PSTN_LEx_6

TP24__S0_01 On receipt of an ESTABLISH message the IUT shall send a STATUS ENQUIRY message and remain in the PSTN_path_state LE0 (Out of Service).

On receipt of a STATUS message containing the cause_type "response to status enquiry" and the state AN0 the IUT shall remain in the PSTN_path_state LE0 (Out of Service).

TP24__S0_02 On receipt of an ESTABLISH ACK message the IUT shall send a STATUS ENQUIRY message and remain in the PSTN_path_state LE0 (Out of Service).

On receipt of a STATUS message containing the cause_type "response to status enquiry" and the state AN0 the IUT shall remain in the PSTN_path_state LE0 (Out of Service).

TP24__S0_03 On receipt of a SIGNAL message the IUT shall send a STATUS ENQUIRY message and remain in the PSTN_path_state LE0 (Out of Service).

On receipt of a STATUS message containing the cause_type "response to status enquiry" and the state AN0 the IUT shall remain in the PSTN_path_state LE0 (Out of Service).

TP24__S0_04 On receipt of a SIGNAL ACK message the IUT shall send a STATUS ENQUIRY message and remain in the PSTN_path_state LE0 (Out of Service).

On receipt of a STATUS message containing the cause_type "response to status enquiry" and the state AN0 the IUT shall remain in the PSTN_path_state LE0 (Out of Service).

- TP24__S0_05 On receipt of a DISCONNECT message the IUT shall send a STATUS ENQUIRY message and remain in the PSTN_path_state LE0 (Out of Service).
- On receipt of a STATUS message containing the cause_type "response to status enquiry" and the state AN0 the IUT shall remain in the PSTN_path_state LE0 (Out of Service).
- TP24__S0_07 On receipt of an unexpected message the IUT shall send a STATUS ENQUIRY message and remain in the PSTN_path_state LE0 (Out of Service).
- On receipt of a STATUS message containing the cause_type "response to status enquiry" and the state AN1 the IUT shall remain in the PSTN_path_state LE0 (Out of Service).
- TP24__S0_08 On receipt of an unexpected message the IUT shall send a STATUS ENQUIRY message and remain in the PSTN_path_state LE0 (Out of Service).
- On receipt of a STATUS message containing the cause_type "response to status enquiry" and the state AN2 the IUT shall remain in the PSTN_path_state LE0 (Out of Service).
- TP24__S0_09 On receipt of an unexpected message the IUT shall send a STATUS ENQUIRY message and remain in the PSTN_path_state LE0 (Out of Service).
- On receipt of a STATUS message containing the cause_type "response to status enquiry" and the state AN3 the IUT shall remain in the PSTN_path_state LE0 (Out of Service).
- TP24__S0_10 On receipt of an unexpected message the IUT shall send a STATUS ENQUIRY message and remain in the PSTN_path_state LE0 (Out of Service).
- On receipt of a STATUS message containing the cause_type "response to status enquiry" and the state AN4 the IUT shall remain in the PSTN_path_state LE0 (Out of Service).
- TP24__S0_11 On receipt of an unexpected message the IUT shall send a STATUS ENQUIRY message and remain in the PSTN_path_state LE0 (Out of Service).
- On receipt of a STATUS message containing the cause_type "response to status enquiry" and the state AN5 the IUT shall remain in the PSTN_path_state LE0 (Out of Service).
- TP24__S0_12 On receipt of an unexpected message the IUT shall send a STATUS ENQUIRY message and remain in the PSTN_path_state LE0 (Out of Service).
- On receipt of a STATUS message containing the cause_type "response to status enquiry" and the state AN6 the IUT shall remain in the PSTN_path_state LE0 (Out of Service).
- TP24__S0_13 On receipt of an unexpected message the IUT shall send a STATUS ENQUIRY message and remain in the PSTN_path_state LE0 (Out of Service).
- On receipt of a STATUS message containing the cause_type "response to status enquiry" and the state AN7 the IUT shall remain in the PSTN_path_state LE0 (Out of Service).

5.3.4.2 V5NWKLE/PSTN/BO/1

Initial state of the IUT: CTRL_COM_INIT, CTRL_PORT_INIT, PSTN_INIT

Preamble: PSTN_LEx_6 & PSTN_LE6_1

Postamble: PSTN_LEx_6

- TP24__S1_01 On receipt of an ESTABLISH ACK message the IUT shall send a STATUS ENQUIRY message.
- On receipt of a STATUS message containing the cause_type "response to status enquiry" and the state AN1 the IUT shall remain in the PSTN_path_state LE1 (Null).
- TP24__S1_02 On receipt of a SIGNAL message the IUT shall send a STATUS ENQUIRY message.
- On receipt of a STATUS message containing the cause_type "response to status enquiry" and the state AN1 the IUT shall remain in the PSTN_path_state LE1 (Null).
- TP24__S1_03 On receipt of a SIGNAL ACK message the IUT shall send a STATUS ENQUIRY message.
- On receipt of a STATUS message containing the cause_type "response to status enquiry" and the state AN1 the IUT shall remain in the PSTN_path_state LE1 (Null).
- TP24__S1_04 On receipt of a SIGNAL ACK message the IUT shall send a STATUS ENQUIRY message.
- On receipt of a STATUS message containing the cause_type "response to status enquiry" and the state AN2 the IUT shall remain in the PSTN_path_state LE1 (Null).
- TP24__S1_05 On receipt of a SIGNAL ACK message the IUT shall send a STATUS ENQUIRY message.
- On receipt of a STATUS message containing the cause_type "response to status enquiry" and the state AN3 the IUT shall remain in the PSTN_path_state LE1 (Null).
- TP24__S1_06 On receipt of a SIGNAL ACK message the IUT shall send a STATUS ENQUIRY message.
- On receipt of a STATUS message containing the cause_type "response to status enquiry" and the state AN4 the IUT shall remain in the PSTN_path_state LE1 (Null).
- TP24__S1_07 On receipt of a SIGNAL ACK message the IUT shall send a STATUS ENQUIRY message.
- On receipt of a STATUS message containing the cause_type "response to status enquiry" and the state AN5 the IUT shall send a DISCONNECT message and enter the new PSTN_path_state LE5 (Path disconnect request).
- TP24__S1_08 On receipt of a SIGNAL ACK message the IUT shall send a STATUS ENQUIRY message.
- On receipt of a STATUS message containing the cause_type "response to status enquiry" and the state AN6 the IUT shall remain in the PSTN_path_state LE1 (Null).
- TP24__S1_09 On receipt of a SIGNAL ACK message the IUT shall send a STATUS ENQUIRY message.
- On receipt of a STATUS message containing the cause_type "response to status enquiry" and the state AN7 the IUT shall remain in the PSTN_path_state LE1 (Null).
- TP24__S1_10 On receipt of a SIGNAL ACK message the IUT shall send a STATUS ENQUIRY message.
- On receipt of a STATUS message containing the cause_type "response to status enquiry" and the state AN0 the IUT shall remain in the PSTN_path_state LE1 (Null).
- TP24__S1_11 On receipt of a DISCONNECT COMPLETE message the IUT shall ignore the message and remain in the PSTN_path_state LE1 (Null).

5.3.4.3 V5NWKLE/PSTN/BO/2

Initial state of the IUT: CTRL_COM_INIT, CTRL_PORT_INIT, PSTN_INIT

Preamble: PSTN_LEx_6 & PSTN_LE6_1 & PSTN_LE1_2

Postamble: PSTN_LEx_6

- TP24__S2_01 On receipt of a SIGNAL message the IUT shall send a STATUS ENQUIRY message.
- On receipt of a STATUS message containing the cause_type "response to status enquiry" and the state AN1 the IUT shall remain in the PSTN_path_state LE2 (Path initiated by LE).
- TP24__S2_02 On receipt of a SIGNAL ACK message the IUT shall send a STATUS ENQUIRY message.
- On receipt of a STATUS message containing the cause_type "response to status enquiry" and the state AN1 the IUT shall remain in the PSTN_path_state LE2 (Path initiated by LE).
- TP24__S2_03 On receipt of a SIGNAL ACK message the IUT shall send a STATUS ENQUIRY message.
- On receipt of a STATUS message containing the cause_type "response to status enquiry" and the state AN2 the IUT shall remain in the PSTN_path_state LE2 (Path initiated by LE).
- TP24__S2_04 On receipt of a SIGNAL ACK message the IUT shall send a STATUS ENQUIRY message.
- On receipt of a STATUS message containing the cause_type "response to status enquiry" and the state AN3 the IUT shall send a DISCONNECT message and enter the new PSTN_path_state LE5 (Path disconnect request).
- TP24__S2_05 On receipt of a SIGNAL ACK message the IUT shall send a STATUS ENQUIRY message.
- On receipt of a STATUS message containing the cause_type "response to status enquiry" and the state AN4 the IUT shall send a DISCONNECT message and enter the new PSTN_path_state LE5 (Path disconnect request).
- TP24__S2_06 On receipt of a SIGNAL ACK message the IUT shall send a STATUS ENQUIRY message.
- On receipt of a STATUS message containing the cause_type "response to status enquiry" and the state AN5 the IUT shall send a DISCONNECT message and enter the new PSTN_path_state LE5 (Path disconnect request).
- TP24__S2_07 On receipt of a SIGNAL ACK message the IUT shall send a STATUS ENQUIRY message.
- On receipt of a STATUS message containing the cause_type "response to status enquiry" and the state AN6 the IUT shall remain in the PSTN_path_state LE2 (Path initiated by LE).
- TP24__S2_08 On receipt of a SIGNAL ACK message the IUT shall send a STATUS ENQUIRY message.
- On receipt of a STATUS message containing the cause_type "response to status enquiry" and the state AN7 the IUT shall remain in the PSTN_path_state LE2 (Path initiated by LE).
- TP24__S2_09 On receipt of a SIGNAL ACK message the IUT shall send a STATUS ENQUIRY message.
- On receipt of a STATUS message containing the cause_type "response to status enquiry" and the state AN0 the IUT shall remain in the PSTN_path_state LE2 (Path initiated by LE).

5.3.4.4 V5NWKLE/PSTN/BO/4

Initial state of the IUT: CTRL_COM_INIT, CTRL_PORT_INIT, PSTN_INIT

Preamble: PSTN_LEx_6 & PSTN_LE6_1 & PSTN_LE1_3_4

Postamble: PSTN_LEx_6

- TP24__S4_01 On receipt of an ESTABLISH message the IUT shall send a STATUS ENQUIRY message.
- On receipt of a STATUS message containing the cause_type "response to status enquiry" and the state AN1 the IUT shall send a DISCONNECT message and enter the new PSTN_path_state LE5 (Path disconnect request).
- TP24__S4_02 On receipt of an ESTABLISH ACK message the IUT shall send a STATUS ENQUIRY message.
- On receipt of a STATUS message containing the cause_type "response to status enquiry" and the state AN1 the IUT shall send a DISCONNECT message and enter the new PSTN_path_state LE5 (Path disconnect request).
- TP24__S4_03 On receipt of an ESTABLISH ACK message the IUT shall send a STATUS ENQUIRY message.
- On receipt of a STATUS message containing the cause_type "response to status enquiry" and the state AN2 the IUT shall send a DISCONNECT message and enter the new PSTN_path_state LE5 (Path disconnect request).
- TP24__S4_04 On receipt of an ESTABLISH ACK message the IUT shall send a STATUS ENQUIRY message.
- On receipt of a STATUS message containing the cause_type "response to status enquiry" and the state AN3 the IUT shall send a DISCONNECT message and enter the new PSTN_path_state LE5 (Path disconnect request).
- TP24__S4_05 On receipt of an ESTABLISH ACK message the IUT shall send a STATUS ENQUIRY message.
- On receipt of a STATUS message containing the cause_type "response to status enquiry" and the state AN4 the IUT shall send a DISCONNECT message and enter the new PSTN_path_state LE5 (Path disconnect request).
- TP24__S4_06 On receipt of an ESTABLISH ACK message the IUT shall send a STATUS ENQUIRY message.
- On receipt of a STATUS message containing the cause_type "response to status enquiry" and the state AN5 the IUT shall remain in the PSTN_path_state LE4 (Path active).
- TP24__S4_07 On receipt of an ESTABLISH ACK message the IUT shall send a STATUS ENQUIRY message.
- On receipt of a STATUS message containing the cause_type "response to status enquiry" and the state AN6 the IUT shall remain in the PSTN_path_state LE4 (Path active).
- TP24__S4_08 On receipt of an ESTABLISH ACK message the IUT shall send a STATUS ENQUIRY message.
- On receipt of a STATUS message containing the cause_type "response to status enquiry" and the state AN7 the IUT shall remain in the PSTN_path_state LE4 (Path active).
- TP24__S4_09 On receipt of an ESTABLISH ACK message the IUT shall send a STATUS ENQUIRY message.
- On receipt of a STATUS message containing the cause_type "response to status enquiry" and the state AN0 the IUT shall remain in the PSTN_path_state LE4 (Path active).

5.3.4.5 V5NWKLE/PSTN/BO/6

Initial state of the IUT: CTRL_COM_INIT, CTRL_PORT_INIT, PSTN_INIT

Preamble: PSTN_LEx_6

Postamble: PSTN_LEx_6

- TP24__S6_01 On receipt of an ESTABLISH message the IUT shall send a STATUS ENQUIRY message.
- On receipt of a STATUS message containing the cause_type "response to status enquiry" and the state AN6 the IUT shall remain in the PSTN_path_state LE6 (Port blocked).
- TP24__S6_02 On receipt of an ESTABLISH ACK message the IUT shall send a STATUS ENQUIRY message.
- On receipt of a STATUS message containing the cause_type "response to status enquiry" and the state AN6 the IUT shall remain in the PSTN_path_state LE6 (Port blocked).
- TP24__S6_03 On receipt of a SIGNAL message the IUT shall send a STATUS ENQUIRY message.
- On receipt of a STATUS message containing the cause_type "response to status enquiry" and the state AN6 the IUT shall remain in the PSTN_path_state LE6 (Port blocked).
- TP24__S6_04 On receipt of a SIGNAL ACK message the IUT shall send a STATUS ENQUIRY message.
- On receipt of a STATUS message containing the cause_type "response to status enquiry" and the state AN6 the IUT shall remain in the PSTN_path_state LE6 (Port blocked).
- TP24__S6_05 On receipt of a DISCONNECT message the IUT shall send a STATUS ENQUIRY message.
- On receipt of a STATUS message containing the cause_type "response to status enquiry" and the state AN6 the IUT shall remain in the PSTN_path_state LE6 (Port blocked).
- TP24__S6_06 On receipt of an unexpected message the IUT shall send a STATUS ENQUIRY message.
- On receipt of a STATUS message containing the cause_type "response to status enquiry" and the state AN0 the IUT shall remain in the PSTN_path_state LE6 (Port blocked).
- TP24__S6_07 On receipt of an unexpected message the IUT shall send a STATUS ENQUIRY message.
- On receipt of a STATUS message containing the cause_type "response to status enquiry" and the state AN1 the IUT shall remain in the PSTN_path_state LE6 (Port blocked).
- TP24__S6_08 On receipt of an unexpected message the IUT shall send a STATUS ENQUIRY message.
- On receipt of a STATUS message containing the cause_type "response to status enquiry" and the state AN2 the IUT shall remain in the PSTN_path_state LE6 (Port blocked).
- TP24__S6_09 On receipt of an unexpected message the IUT shall send a STATUS ENQUIRY message.
- On receipt of a STATUS message containing the cause_type "response to status enquiry" and the state AN3 the IUT shall remain in the PSTN_path_state LE6 (Port blocked).
- TP24__S6_10 On receipt of an unexpected message the IUT shall send a STATUS ENQUIRY message.
- On receipt of a STATUS message containing the cause_type "response to status enquiry" and the state AN4 the IUT shall remain in the PSTN_path_state LE6 (Port blocked).
- TP24__S6_11 On receipt of an unexpected message the IUT shall send a STATUS ENQUIRY message.
- On receipt of a STATUS message containing the cause_type "response to status enquiry" and the state AN5 the IUT shall remain in the PSTN_path_state LE6 (Port blocked).

- TP24__S6_13 On receipt of an unexpected message the IUT shall send a STATUS ENQUIRY message.
- On receipt of a STATUS message containing the cause_type "response to status enquiry" and the state AN7 the IUT shall remain in the PSTN_path_state LE6 (Port blocked).
- TP24__S6_14 On receipt of an ESTABLISH message the IUT shall send a STATUS ENQUIRY message.
- On receipt of a STATUS message containing the cause_type "response to status enquiry" and the state AN1 the IUT remain in the PSTN_path_state LE6 (Port blocked).

5.3.5 Invalid behaviour tests (V5NWKLE/PSTN/BI)

Refer to EN 300 324-1 [1], subclause 13.5.2.

5.3.5.1 V5NWKLE/PSTN/BI/1

Initial state of the IUT: CTRL_COM_INIT, CTRL_PORT_INIT, PSTN_INIT

Preamble: PSTN_LEx_6 & PSTN_LE6_1

Postamble: PSTN_LEx_6

- TP25__S1_01 Check that the IUT discards messages containing less than 4 octets and remains in the PSTN_path_state LE1 (Null).
- TP25__S1_02 (protocol discriminator error)
- Check that the IUT discards an ESTABLISH message (sends no ESTABLISH ACK message) containing an unspecified protocol_discriminator IE and remains in the PSTN_path_state LE1 (Null).
- TP25__S1_03 (L3addr error)
- Check that the IUT discards an ESTABLISH message (sends no ESTABLISH ACK message) containing an unprovisioned L3addr and remains in the PSTN_path_state LE1 (Null).
- TP25__S1_04 (message type error)
- Check that the IUT discards a message containing an unspecified message_type IE and remains in the PSTN_path_state LE1 (Null).
- TP25__S1_05 (repeated optional IEs)
- On receipt of an ESTABLISH message containing more than 3 repeated valid optional IEs the IUT shall send an ESTABLISH ACK message and enter the PSTN_path_state LE4 (Path active).
- TP25__S1_06 (unrecognized IE)
- On receipt of an ESTABLISH message containing one unspecified IE the IUT shall send an ESTABLISH ACK message and enter the PSTN_path_state LE4 (Path active).
- TP25__S1_07 (content error of optional IE)
- On receipt of an ESTABLISH message containing one incorrect conditional IE the IUT shall send an ESTABLISH ACK message and enter the PSTN_path_state LE4 (Path active).
- TP25__S1_08 (optional IE not allowed)
- Check that the IUT discards an ESTABLISH message (sends no ESTABLISH ACK message) containing two different valid conditional IEs and remains in the PSTN_path_state LE1 (Null).

5.3.5.2 V5NWKLE/PSTN/BI/4

Initial state of the IUT: CTRL_COM_INIT, CTRL_PORT_INIT, PSTN_INIT

Preamble: PSTN_LEx_6 & PSTN_LE6_1 & PSTN_LE1_3_4

Postamble: PSTN_LEx_6

- TP25__S4_01 (IE out of sequence)
- Check that the IUT discards a SIGNAL message (sends no SIGNAL ACK message) containing a valid conditional IE and the correct sequence_number IE out of sequence.
- TP25__S4_02 (repeated mandatory IEs)
- Check that the IUT discards a SIGNAL ACK message (sends no DISCONNECT message) containing two repeated sequence_number IEs (each containing invalid sequence numbers).
- TP25__S4_03 (mandatory IE missing)
- Check that the IUT discards a SIGNAL message (sends no SIGNAL ACK message) containing no sequence_number IE.
- TP25__S4_04 Check that the IUT discards a SIGNAL message (sends no SIGNAL ACK message) containing no conditional IE.
- TP25__S4_05 (content error of mandatory IE)
- Check that the IUT discards a SIGNAL message (sends no SIGNAL ACK message) containing an invalid length of the mandatory IE "sequence_number".
- TP25__S4_06 Check that the IUT discards a SIGNAL message (sends no SIGNAL ACK message) containing two conditional IEs.

5.3.6 Timer expiry and counter mismatch tests (V5NWKLE/PSTN/TI)

Refer to EN 300 324-1 [1], table 30 and subclause L.2.4.

5.3.6.1 V5NWKLE/PSTN/TI/0

Initial state of the IUT: CTRL_COM_INIT, CTRL_PORT_INIT, PSTN_INIT

Preamble: PSTN_LEx_6 & PSTN_LE6_1 & PSTN_LE1_0

Postamble: PSTN_LE0_1 & PSTN_LEx_6

- TP26__S0_01 On receipt of a SIGNAL ACK message the IUT shall send a STATUS ENQUIRY message.
- On time-out of timer T4 the IUT shall repeat sending the STATUS ENQUIRY message.
- On receipt of a STATUS message containing the cause_type "response to status enquiry" and the state IE AN0 after N4 repetitions of the STATUS ENQUIRY message the IUT shall remain in the PSTN_path_state LE0 (Out of Service).
- TP26__S0_02 On receipt of a SIGNAL ACK message the IUT shall send a STATUS ENQUIRY message.
- On time-out of timer T4 the IUT shall repeat sending the STATUS ENQUIRY message.
- On N4+1 time-outs of timer T4 the IUT shall stop repeating the STATUS ENQUIRY message and remain in the PSTN_path_state LE0 (Out of Service).

- TP26__S0_03 On receipt of a SIGNAL ACK message the IUT shall send a STATUS ENQUIRY message.
- On time-out of timer T4 after receiving a STATUS message containing not the cause_type "response to status enquiry" the IUT shall repeat sending the STATUS ENQUIRY message.
- On receipt of a STATUS message containing the cause_type "response to status enquiry" and the state AN0 the IUT shall remain in the PSTN_path_state LE0 (Out of Service).

5.3.6.2 V5NWKLE/PSTN/TI/1

Initial state of the IUT: CTRL_COM_INIT, CTRL_PORT_INIT, PSTN_INIT

Preamble: PSTN_LEx_6 & PSTN_LE6_1

Postamble: PSTN_LEx_6

- TP26__S1_01 On receipt of a SIGNAL ACK message the IUT shall send a STATUS ENQUIRY message.
- On time-out of timer T4 the IUT shall repeat sending the STATUS ENQUIRY message.
- On receipt of a STATUS message containing the cause_type "response to status enquiry" and the state IE AN1 after N4 repetitions of the STATUS ENQUIRY message the IUT shall remain in the PSTN_path_state LE1 (Null).
- TP26__S1_02 On receipt of a SIGNAL ACK message the IUT shall send a STATUS ENQUIRY message.
- On time-out of timer T4 the IUT shall repeat sending the STATUS ENQUIRY message.
- On N4+1 time-outs of timer T4 the IUT shall send a DISCONNECT message and enter the new PSTN_path_state LE5 (Path disconnect request).
- TP26__S1_03 On receipt of a SIGNAL ACK message the IUT shall send a STATUS ENQUIRY message.
- On time-out of timer T4 after receiving a STATUS message containing not the cause_type "response to status enquiry" the IUT shall repeat sending the STATUS ENQUIRY message.
- On receipt of a STATUS message containing the cause_type "response to status enquiry" and the state AN1 the IUT shall remain in the PSTN_path_state LE1 (Null).

5.3.6.3 V5NWKLE/PSTN/TI/2

Initial state of the IUT: CTRL_COM_INIT, CTRL_PORT_INIT, PSTN_INIT

Preamble: PSTN_LEx_6 & PSTN_LE6_1 & PSTN_LE1_2

Postamble: PSTN_LEx_6

- TP26__S2_01 On time-out of timer T1 the IUT shall repeat sending the ESTABLISH message.
(*)
- On receipt of an ESTABLISH ACK message after N1 repetitions of the ESTABLISH message the IUT shall enter the new PSTN_path_state LE4 (Path active).
- TP26__S2_02 On time-out of timer T1 the IUT shall repeat sending the ESTABLISH message.
(*)
- On N1+1 time-outs of timer T1 the IUT shall send a DISCONNECT message and enter the new PSTN_path_state LE5 (Path disconnect request).

5.3.6.4 V5NWKLE/PSTN/TI/4

Initial state of the IUT: CTRL_COM_INIT, CTRL_PORT_INIT, PSTN_INIT

Preamble: PSTN_LEx_6 & PSTN_LE6_1 & PSTN_LE1_3_4

Postamble: PSTN_LEx_6

- TP26__S4_01 Refer to TP23__S4_01 in subclause 5.3.3.3.
- TP26__S4_02 On time-out of timer Tt after sending a SIGNAL message the IUT shall send a DISCONNECT message and enter the new PSTN_path_state LE5 (Path disconnect request).
- TP26__S4_03 On reception of a SIGNAL ACK message acknowledging not all outstanding SIGNAL messages the IUT shall restart Timer Tt.
- On time-out of timer Tt the IUT shall send a DISCONNECT message and enter the new PSTN_path_state LE5 (Path disconnect request).
- TP26__S4_04 On receipt of a SIGNAL message containing a faulty sequence number the IUT shall send a DISCONNECT message and enter the new PSTN_path_state LE5 (Path disconnect request).
- TP26__S4_05 On receipt of a SIGNAL ACK message containing a faulty sequence number after sending a SIGNAL message the IUT shall send a DISCONNECT message and enter the new PSTN_path_state LE5 (Path disconnect request).
- TP26__S4_06 On receipt of an ESTABLISH ACK message the IUT shall send a STATUS ENQUIRY message.
- On time-out of timer T4 the IUT shall repeat sending the STATUS ENQUIRY message.
- On receipt of a STATUS message containing the cause_type "response to status enquiry" and the state IE AN5 after N4 repetitions of the STATUS ENQUIRY message the IUT shall remain in the PSTN_path_state LE4 (Path active).
- TP26__S4_07 On receipt of an ESTABLISH ACK message the IUT shall send a STATUS ENQUIRY message.
- On time-out of timer T4 the IUT shall repeat sending the STATUS ENQUIRY message.
- On N4+1 time-outs of timer T4 the IUT shall send a DISCONNECT message and enter the new PSTN_path_state LE5 (Path disconnect request).
- TP26__S4_08 On receipt of an ESTABLISH ACK message the IUT shall send a STATUS ENQUIRY message.
- On time-out of timer T4 after receiving a STATUS message containing not the cause_type "response to status enquiry" the IUT shall repeat sending the STATUS ENQUIRY message.
- On receipt of a STATUS message containing the cause_type "response to status enquiry" and the state AN5 the IUT shall remain in the PSTN_path_state LE4 (Path active).

5.3.6.5 V5NWKLE/PSTN/TI/5

Initial state of the IUT: CTRL_COM_INIT, CTRL_PORT_INIT, PSTN_INIT

Preamble: PSTN_LEx_6 & PSTN_LE6_1 & PSTN_LE1_3_4 & PSTN_LE4_5

Postamble: PSTN_LEx_6

TP26__S5_01 On time-out of timer T3 the IUT shall repeat sending the DISCONNECT message.

On receipt of a DISCONNECT COMPLETE message after N3 repetitions of the DISCONNECT message the IUT shall enter the new PSTN_path_state LE1 (Null).

TP26__S5_02 On time-out of timer T3 the IUT shall repeat sending the DISCONNECT message.

On N3+1 time-outs of timer T3 the IUT shall repeat sending the DISCONNECT message and remain in the PSTN_path_state LE5 (Path disconnect request).

On receipt of a DISCONNECT COMPLETE message after N3+2 repetitions of the DISCONNECT message the IUT shall enter the new PSTN_path_state LE1 (Null).

5.3.6.6 V5NWKLE/PSTN/TI/6

Initial state of the IUT: CTRL_COM_INIT, CTRL_PORT_INIT, PSTN_INIT

Preamble: -

Postamble: PSTN_LEx_6

TP26__S6_01 On receipt of a SIGNAL ACK message the IUT shall send a STATUS ENQUIRY message.

On time-out of timer T4 the IUT shall repeat sending the STATUS ENQUIRY message.

On receipt of a STATUS message containing the cause_type "response to status enquiry" and the state IE AN6 after N4 repetitions of the STATUS ENQUIRY message the IUT shall remain in the PSTN_path_state LE6 (Port blocked).

TP26__S6_02 On receipt of a SIGNAL ACK message the IUT shall send a STATUS ENQUIRY message.

On time-out of timer T4 the IUT shall repeat sending the STATUS ENQUIRY message.

On N4+1 time-outs of timer T4 the IUT shall stop repeating the STATUS ENQUIRY message and remain in the PSTN_path_state LE6 (Port blocked).

TP26__S6_03 On receipt of a SIGNAL ACK message the IUT shall send a STATUS ENQUIRY message.

On time-out of timer T4 after receiving a STATUS message containing not the cause_type "response to status enquiry" the IUT shall repeat sending the STATUS ENQUIRY message.

On receipt of a STATUS message containing the cause_type "response to status enquiry" and the state AN6 the IUT shall remain in the PSTN_path_state LE6 (Port blocked).

Bibliography

The following material, though not specifically referenced in the body of the present document (or not publicly available), gives supporting information.

- ETS 300 406: "Methods for Testing and Specification (MTS); Protocol and profile conformance testing specifications; Standardization methodology".

History

Document history		
Edition 1	October 1995	Publication as ETS 300 324-5
Edition 2	April 1999	Publication as ETS 300 324-5
V3.1.1	December 1999	Public Enquiry PE 200017: 1999-12-29 to 2000-04-28