

Final draft **ETSI EN 300 294** V1.4.1 (2002-12)

---

*European Standard (Telecommunications series)*

**Television systems;  
625-line television  
Wide Screen Signalling (WSS)**

---

European Broadcasting Union



Union Européenne de Radio-Télévision

EBU·UER



---

Reference

REN/JTC-WSS-3

---

Keywords

analogue, signalling, TV, wide screen

**ETSI**

650 Route des Lucioles  
F-06921 Sophia Antipolis Cedex - FRANCE

Tel.: +33 4 92 94 42 00 Fax: +33 4 93 65 47 16

Siret N° 348 623 562 00017 - NAF 742 C  
Association à but non lucratif enregistrée à la  
Sous-Préfecture de Grasse (06) N° 7803/88

---

**Important notice**

Individual copies of the present document can be downloaded from:

<http://www.etsi.org>

The present document may be made available in more than one electronic version or in print. In any case of existing or perceived difference in contents between such versions, the reference version is the Portable Document Format (PDF). In case of dispute, the reference shall be the printing on ETSI printers of the PDF version kept on a specific network drive within ETSI Secretariat.

Users of the present document should be aware that the document may be subject to revision or change of status. Information on the current status of this and other ETSI documents is available at

<http://portal.etsi.org/tb/status/status.asp>

---

**Copyright Notification**

No part may be reproduced except as authorized by written permission.  
The copyright and the foregoing restriction extend to reproduction in all media.

© European Telecommunications Standards Institute 2002.

© European Broadcasting Union 2002.

All rights reserved.

**DECT**<sup>TM</sup>, **PLUGTESTS**<sup>TM</sup> and **UMTS**<sup>TM</sup> are Trade Marks of ETSI registered for the benefit of its Members.  
**TIPHON**<sup>TM</sup> and the **TIPHON logo** are Trade Marks currently being registered by ETSI for the benefit of its Members.  
**3GPP**<sup>TM</sup> is a Trade Mark of ETSI registered for the benefit of its Members and of the 3GPP Organizational Partners.

# Contents

Intellectual Property Rights .....	4
Foreword.....	4
Introduction .....	4
1 Scope .....	5
2 References .....	5
3 Definition, symbols and abbreviations .....	5
3.1 Definition .....	5
3.2 Symbols.....	5
3.3 Abbreviations .....	6
4 Requirements.....	6
4.1 Line code .....	6
4.1.1 Position .....	6
4.1.2 Clock frequency .....	7
4.1.3 Pulse shape.....	7
4.1.4 Signal amplitude .....	7
4.1.5 Modulation coding.....	7
4.1.6 Preamble .....	8
4.1.7 Data bits .....	8
4.1.8 Odd parity bit.....	8
4.2 Information content of data bits .....	10
4.2.1 Data group 1 .....	10
4.2.1.1 Aspect ratio .....	10
4.2.2 Data group 2, enhanced services.....	11
4.2.2.1 Film bit.....	11
4.2.2.2 Colour coding bit .....	11
4.2.2.3 Helper bit .....	11
4.2.2.4 Bit b <sub>7</sub> .....	11
4.2.3 Data group 3, subtitles .....	12
4.2.3.1 Subtitles within Teletext bit .....	12
4.2.3.2 Subtitling mode .....	12
4.2.4 Data group 4, others.....	12
4.2.4.1 Surround sound bit .....	12
4.2.4.2 Copyright information.....	13
<b>Annex A (informative): Rules of operation .....</b>	<b>14</b>
A.1 Receiver display formats .....	14
A.2 Subtitling .....	14
A.3 Procedure in absence of signalling .....	15
<b>Annex B (informative): Recommendations .....</b>	<b>16</b>
B.1 Low pass pre-filtering .....	16
B.2 Response time on a change in the received signalling information .....	16
<b>Annex C (informative): Guidelines .....</b>	<b>17</b>
C.1 Copyright information.....	17
<b>Annex D (informative): Future use of bit 7 .....</b>	<b>18</b>
History .....	20

---

## Intellectual Property Rights

IPRs essential or potentially essential to the present document may have been declared to ETSI. The information pertaining to these essential IPRs, if any, is publicly available for **ETSI members and non-members**, and can be found in ETSI SR 000 314: "*Intellectual Property Rights (IPRs); Essential, or potentially Essential, IPRs notified to ETSI in respect of ETSI standards*", which is available from the ETSI Secretariat. Latest updates are available on the ETSI Web server (<http://webapp.etsi.org/IPR/home.asp>).

Pursuant to the ETSI IPR Policy, no investigation, including IPR searches, has been carried out by ETSI. No guarantee can be given as to the existence of other IPRs not referenced in ETSI SR 000 314 (or the updates on the ETSI Web server) which are, or may be, or may become, essential to the present document.

---

## Foreword

This European Standard (Telecommunications series) has been produced by Joint Technical Committee (JTC) Broadcast of the European Broadcasting Union (EBU), Comité Européen de Normalisation ELECTrotechnique (CENELEC) and the European Telecommunications Standards Institute (ETSI), and is now submitted for the ETSI standards One-step Approval Procedure.

**NOTE:** The EBU/ETSI JTC Broadcast was established in 1990 to co-ordinate the drafting of standards in the specific field of broadcasting and related fields. Since 1995 the JTC Broadcast became a tripartite body by including in the Memorandum of Understanding also CENELEC, which is responsible for the standardization of radio and television receivers. The EBU is a professional association of broadcasting organizations whose work includes the co-ordination of its members' activities in the technical, legal, programme-making and programme-exchange domains. The EBU has active members in about 60 countries in the European broadcasting area; its headquarters is in Geneva.

European Broadcasting Union  
CH-1218 GRAND SACONNEX (Geneva)  
Switzerland  
Tel: +41 22 717 21 11  
Fax: +41 22 717 24 81

<b>Proposed national transposition dates</b>	
Date of latest announcement of this EN (doa):	3 months after ETSI publication
Date of latest publication of new National Standard or endorsement of this EN (dop/e):	6 months after doa
Date of withdrawal of any conflicting National Standard (dow):	6 months after doa

---

## Introduction

For a smooth introduction of new television services with a 16:9 display aspect ratio in PAL and SECAM standards, it is necessary to signal the aspect ratio used together with some switching information to the television receiver. The receiver should be capable of reacting automatically to this information by displaying the video information in a specified aspect ratio. This signalling is to be considered separately from the type of system used, but it should allow transmission of system related switching information as well.

The present document permits the later allocation of additional switching information, related to the introduction of enhanced television services.

The present document is applicable for 625-line PAL and SECAM television systems, but there is potential to adopt it to other standards as well.

---

# 1 Scope

The present document is applicable to 625-line PAL and SECAM systems in use, in case, where wide screen signalling is required by the broadcasters.

It specifies the wide screen signalling information, the coding and the way of incorporating the coded information into a 625-line system.

The wide screen signalling information contains information on the aspect ratio range of the transmitted signal and its position, on the position of the subtitles and on the camera/film mode. Furthermore signalling for EDTV and for surround sound is included. Some bits are reserved for future use.

The present document specifies the transmitted signal. Annex A gives the rules of operation for the minimum requirements for receiver display formats as well as for subtitling. Annex B gives recommendations. Annex C gives a guideline for copyright information. Annex D describes how the one remaining unused bit can be used to convey multi-bit information.

---

# 2 References

The following documents contain provisions which, through reference in this text, constitute provisions of the present document.

- References are either specific (identified by date of publication and/or edition number or version number) or non-specific.
- For a specific reference, subsequent revisions do not apply.
- For a non-specific reference, the latest version applies.

[1] EBU Recommendation R62 (1998): "Recommended dominant field for 625-line 50-Hz video processing".

---

# 3 Definition, symbols and abbreviations

## 3.1 Definition

For the purposes of the present document, the following definition applies:

**letterbox operation:** use of a picture format with an aspect ratio greater than 1,33, in such a way that empty (black) lines are added to conform to a 4:3 transmission format

## 3.2 Symbols

For the purposes of the present document, the following symbols apply:

a	aspect ratio
$F_s$	clock frequency
$0_h$	falling sync edge
$T_d$	data bit period
$T_s$	sampling period

### 3.3 Abbreviations

For the purposes of the present document, the following abbreviations apply:

EDTV	Enhanced Definition TeleVision
LSB	Least Significant Bit
MSB	Most Significant Bit
NRZ	Non-Return-to-Zero
PAL	Phase Alternation Line (Colour TV-System)
SECAM	Sequentielle Couleur Avec Memoire (French Colour-TV System)
WSS	Wide Screen Signalling

## 4 Requirements

### 4.1 Line code

The following clauses specify the line code of the Wide Screen Signalling (WSS).

#### 4.1.1 Position

The signalling bits shall be transmitted as a data burst in the first part of line 23.

The position of the beginning of the Wide Screen Signalling bits shall be  $11,0 \pm 0,25 \mu\text{s}$  from 0h of the horizontal sync, as indicated in figure 1. This figure is intended to illustrate the position of the signalling bits in line 23. For the purpose of commonality between PAL and SECAM, the colour burst and chrominance sub-carrier are not shown.

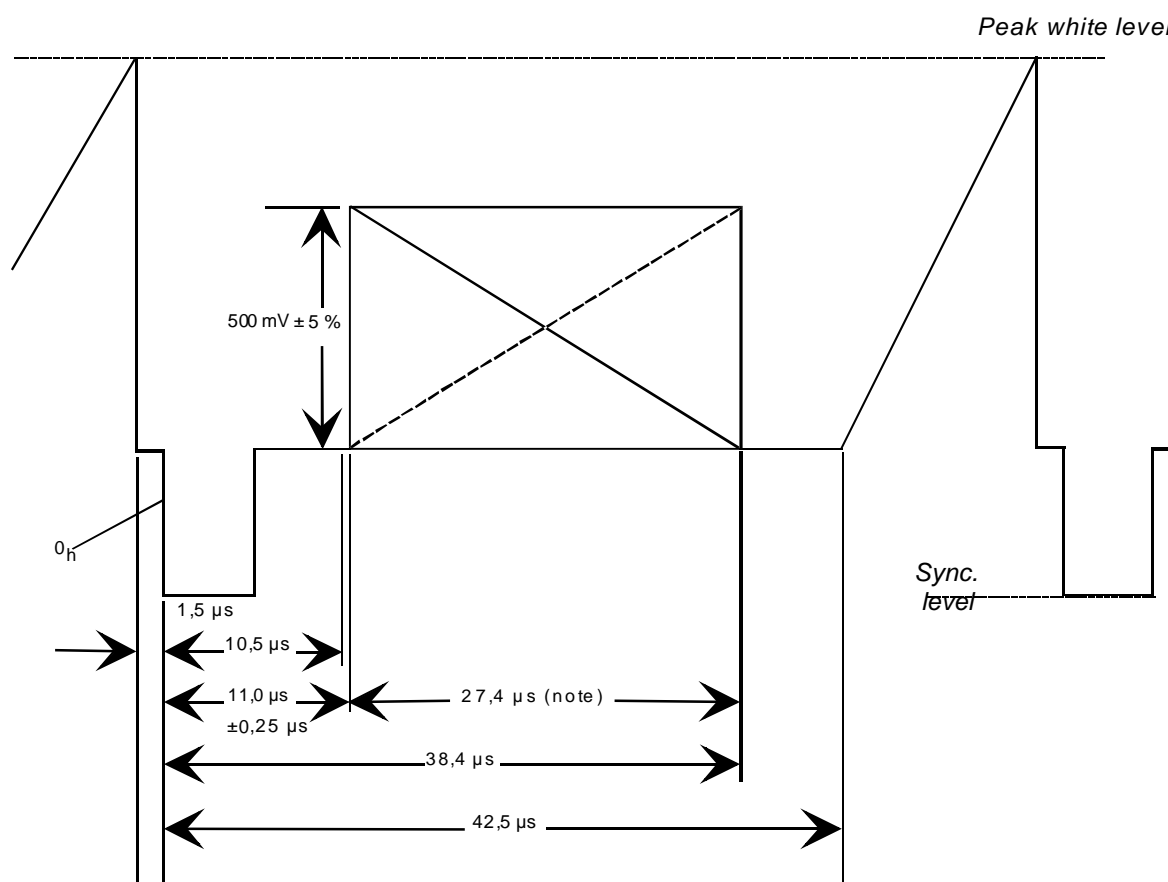

NOTE: For optimum decoder performance, it is recommended that this period is free from other signals.

Figure 1: Position of status bit signalling in line 23

In each frame line 23 shall be occupied with the WSS.

#### 4.1.2 Clock frequency

The clock frequency shall be:  $F_s = 5 \text{ MHz } (\pm 1 \times 10^{-4})$ ;

The period shall be:  $T_s = 200 \text{ ns}$ .

#### 4.1.3 Pulse shape

The pulse shaping function  $h(\tau)$  shall be approximately a sine square:

$$h(\tau) \approx \begin{cases} \frac{2}{T_s} \sin^2\left(\frac{\pi\tau}{2T_s} + \frac{\pi}{2}\right) & |\tau| \leq T_s \\ 0 & \textit{elsewhere} \end{cases}$$

The half amplitude pulse duration shall be:  $200 \text{ ns } \pm 10 \text{ ns}$ .

#### 4.1.4 Signal amplitude

The signal amplitude with respect to a maximum video signal amplitude of 700 mV shall be:

$$0,5 \text{ V } \pm 5 \%$$

#### 4.1.5 Modulation coding

Bi-phase coding shall be used in accordance with figure 2.

Duration of one data bit:  $T_d$

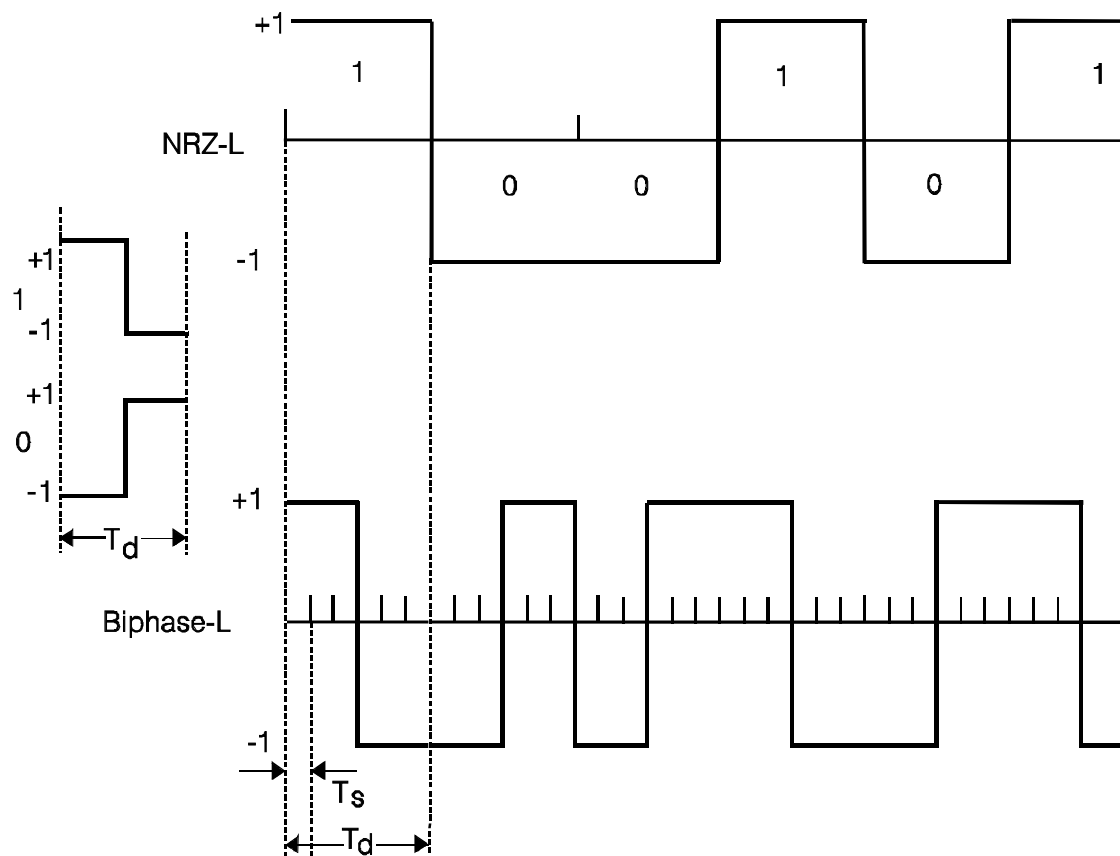

**Figure 2: Example of bi-phase-L coding**

The data bits shall be inserted in bi-phase-L, in which one data bit period equals  $2 \times 3$  clock periods, whereby:

$$T_d = 6T_s$$

#### 4.1.6 Preamble

The preamble contains a run-in and a start code. The preamble shall be in accordance with table 1.

#### 4.1.7 Data bits

There shall be 14 bits in total. 1 out of these 14 bits shall be allocated to the error detection code. There shall be 13 data-bits available for transmission of information. The data bits shall be grouped in 4 data groups, see table 1.

#### 4.1.8 Odd parity bit

For error detection, an odd parity bit has been introduced. The odd parity bit shall belong to the first 3 data bits only, see table 1.



Table 1: Status bits transmission scheme

<b>Status bits transmission</b>					
Insertion: First half of line 23    Coding: Bi-phase modulation coding    Clock: 5 MHz (Ts = 200 ns)					
Run-in	Start code	Group 1 Aspect Ratio	Group 2 Enhanced Services	Group 3 Subtitles	Group 4 Others
29 elements based on 5 MHz	24 elements based on 5 MHz	24 elements based on 5 MHz	24 elements based on 5 MHz	18 elements based on 5 MHz	18 elements based on 5 MHz
		bit numbering 0 1 2 3 LSB MSB per info bit (note) "0" = 000 111 "1" = 111 000	bit numbering 4 5 6 7 LSB MSB per info bit (note) "0" = 000 111 "1" = 111 000	bit numbering 8 9 10 LSB MSB per info bit (note) "0" = 000 111 "1" = 111 000	bit numbering 11 12 13 LSB MSB per info bit (note) "0" = 000 111 "1" = 111 000
MSB transmitted first	MSB transmitted first	LSB transmitted first	LSB transmitted first	LSB transmitted first	LSB transmitted first
0 × 1F1C 71C7 1 1111 0001 1100 0111 0001 1100 0111 MSB        LSB	0 × 1E 3C1F 0001 1110 0011 1100 0001 1111 MSB        LSB	0123 bit number 0001 full format 4:3 1000 box 14:9 Centre 0100 box 14:9 Top 1101 box 16:9 Centre 0010 box 16:9 Top 1011 box > 16:9 Centre 0111 full format 4:3 (shoot and protect 14:9 Centre)  1110 full format 16:9 (anamorphic)  b <sub>3</sub> = Odd Parity Bit	4 bit number 0 Camera mode 1 Film mode  5 bit number 0 standard coding 1 Motion Adaptive Colour Plus  6 bit number 0 no helper 1 modulated helper  b <sub>7</sub> = Reserved Should be set to "0"	8 bit number 0 no subtitles within Teletext  1 subtitles within Teletext  9 10 bit number 0 0 no open subtitles 1 0 subtitles in active image area  0 1 subtitles out of active image area  1 1 reserved	11 bit number 0 no surround sound information 1 surround sound mode  12 bit number  0 no copy right asserted or status unknown 1 copy right asserted  13 bit number  0 copying not restricted 1 copying restricted
NOTE: One info bit consists of 6 elements based on 5 MHz clock. Td = 6Ts (see clauses 3.2 and 4.1.5).					

## 4.2 Information content of data bits

The 13 data bits shall be grouped in 4 groups.

Group 1 shall contain 4 bits in which the first 3 bits carry data and the last bit shall denote the odd parity bit over the first three data bits. Group 2 shall contain 4 data bits, group 3 shall contain 3 data bits and group 4 shall contain 3 data bits.

The data bits shall be labelled  $b_0$  up to and including  $b_2$  combined with  $b_4$  up to and including  $b_{13}$ .  $b_3$  shall be the odd parity bit as is shown in tables 1 and 2. The index also indicates the order of transmission:  $b_0$  shall be the first transmitted bit.

### 4.2.1 Data group 1

#### 4.2.1.1 Aspect ratio

$b_0, b_1, b_2$ : shall denote the aspect ratio label, the letterbox format and position according to table 2.

$b_3$ : shall denote the odd parity of  $b_0, b_1, b_2, b_3$  according to table 2.

**Table 2: Aspect ratio label, letterbox and position code**

$b_0b_1b_2$	$b_3$	Aspect ratio label	Full format or Letterbox	Position	No. of active lines (note 1)
0 0 0	1	4:3	full format	not applicable	576
1 0 0	0	14:9	letterbox	centre	504
0 1 0	0	14:9	letterbox	top	504
1 1 0	1	16:9	letterbox	centre	430
0 0 1	0	16:9	letterbox	top	430
1 0 1	1	> 16:9	letterbox	centre	not defined
0 1 1	1	14:9	full format (note 2)	centre	576
1 1 1	0	16:9	full format (anamorphic)	not applicable	576

NOTE 1: The number of active lines is only an indication for the exact aspect ratio  $a = 1,33$ ,  $a = 1,57$  and  $a = 1,78$ .

NOTE 2: The actual transmitted aspect ratio is 4:3, but a 14:9 centre window should contain all the relevant picture content to encourage a wide screen display on a 16:9 television set.

The aspect ratio label indicates a range of possible aspect ratio. All aspect ratio's falling in these ranges shall be labelled by the same code. Table 3 indicates the aspect ratio ranges.

**Table 3: Aspect ratio ranges**

Aspect ratio label	Aspect ratio range	Active lines
4:3	$a \leq 1,46$	527 to 576
14:9	$1,46 < a \leq 1,66$	463 to 526
16:9	$1,66 < a \leq 1,90$	405 to 462
> 16:9	$a > 1,90$	< 405

## 4.2.2 Data group 2, enhanced services

### 4.2.2.1 Film bit

$b_4$ : shall denote the film bit in accordance with table 4.

**Table 4: Film bit**

$b_4$	Film bit
0	camera mode (note 1)
1	film mode (notes 2 and 3)
NOTE 1: Use "camera mode" as default mode.	
NOTE 2: The field dominance shall conform to the EBU Recommendation R62 [1].	
NOTE 3: It is recommended to use the "film mode" in case of still picture transmissions.	

### 4.2.2.2 Colour coding bit

$b_5$ : shall denote the colour coding bit in accordance with table 5.

**Table 5: Colour coding bit**

$b_5$	Colour coding bit
0	standard coding
1	Motion Adaptive Colour Plus (note)
NOTE: In film mode (bit $b_4 = 1$ ), Motion Adaptive Colour Plus is set to "fixed" Colour Plus operation, i.e. it is not motion adaptive.	

### 4.2.2.3 Helper bit

$b_6$ : shall denote the helper bit in accordance with table 6.

**Table 6: Helper bit**

$b_6$	Helper bit
0	No helper
1	Modulated helper (note)
NOTE: A helper signal may be present only when the aspect ratio label is either "16:9 letterbox centre" or "> 16:9 letterbox centre" and the number of active lines $\leq 430$ lines.	

### 4.2.2.4 Bit $b_7$

Bit  $b_7$ : reserved, should be set to "0" see annex D.

## 4.2.3 Data group 3, subtitles

### 4.2.3.1 Subtitles within Teletext bit

$b_8$ : shall denote the subtitles within Teletext bit in accordance with table 7.

**Table 7: Subtitles within Teletext bit**

$b_8$	Subtitles within Teletext bit
0	no subtitles within Teletext
1	subtitles within Teletext

### 4.2.3.2 Subtitling mode

$b_9, b_{10}$ : shall denote the mode of subtitling in accordance with table 8.

**Table 8: Subtitling mode**

$b_9 b_{10}$	subtitles in/out of active image area
0 0	no open subtitles
1 0	subtitles in active image area
0 1	subtitles out of active image area
1 1	reserved

NOTE: The "out of active image area" subtitling, which extends into the active image area shall be treated as "out of active image area".

Figure 3 indicates the meaning of the terms "in active image area" and "out of active image area".

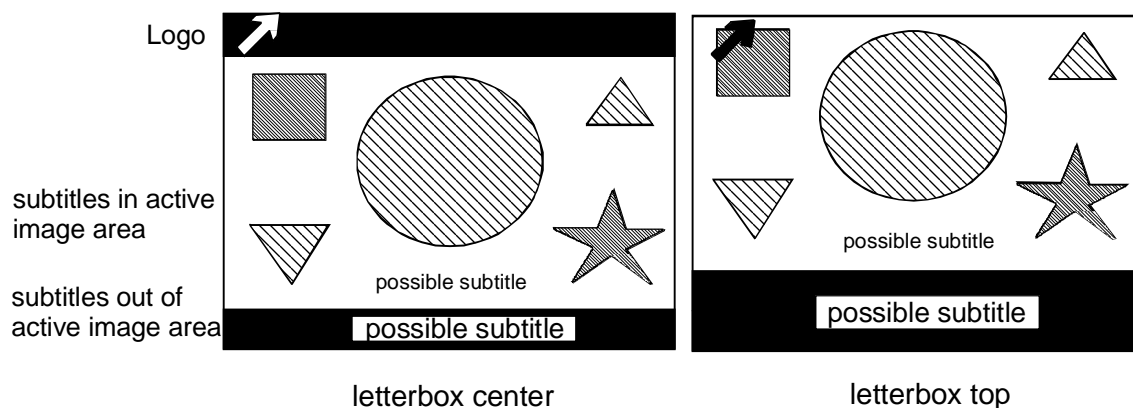

**Figure 3: Examples of letterbox signals with logos and subtitling**

## 4.2.4 Data group 4, others

### 4.2.4.1 Surround sound bit

$b_{11}$ : shall denote the surround sound bit in accordance with table 9.

**Table 9: Surround sound bit**

$b_{11}$	Surround sound bit
0	no surround sound information
1	surround sound mode

#### 4.2.4.2 Copyright information

$b_{12}$ ,  $b_{13}$ : shall denote the copyright bit and generation bit in accordance with table 10.

**Table 10: Copyright information**

<b><math>b_{12}</math></b>	<b>Copyright bit</b>
0	no copyright asserted or status unknown
1	copyright asserted
<b><math>b_{13}</math></b>	<b>Generation bit</b>
0	copying not restricted
1	copying restricted

---

## Annex A (informative): Rules of operation

### A.1 Receiver display formats

To ensure automatic selection of the most appropriate display mode, the receiver with a 16:9 display should comply with the following minimum requirements:

**Table A.1: Aspect ratio minimum requirements**

$b_0b_1b_2$	Aspect ratio label	Minimum requirements
0 0 0	4:3	case 1
1 0 0	14:9	case 2
0 1 0	14:9	case 2
1 1 0	16:9	case 3
0 0 1	16:9	case 3
1 0 1	> 16:9	case 4

- Case 1: 4:3 Full format: The 4:3 aspect ratio picture should be displayed centred with black bars at the left and right hand side of the display.
- Case 2: Letterbox signalled as 14:9: the 14:9 aspect ratio picture should be displayed using one of the following two methods:
- the 14:9 aspect ratio picture should be displayed centred with small bars at the left and right hand sides of the display;
  - the 14:9 picture may be displayed filling the full width of the visible screen by incorporating a small horizontal geometrical error, typically 8 %.
- Case 3: Letterbox signalled as 16:9: the 16:9 aspect ratio picture should be displayed using the full width of the screen.
- Case 4: Letterbox signalled as > 16:9: the > 16:9 aspect ratio picture should be displayed using one of the following two methods:
- as under case 3;
  - the > 16:9 picture may be displayed using the full height of the screen, by further zooming in.

It should be noted that the viewer should be free to override the automatically selected display condition.

The speed of the automatic change of aspect ratio is limited mainly by the response time of the deflection circuit.

---

### A.2 Subtitling

When the subtitling of letterboxed pictures is in, or partly in the "out-of active image area", the new 16:9 receivers will lose this information, unless they display the picture in the 4:3 mode. This would mean that on the 16:9 receiver, black bars would be present all around the active image content and this should be avoided.

To serve both the interests of the existing 4:3 and the new 16:9 viewers, it is of great importance, that:

- wide screen programmes should always have the subtitling (whether "in active image area" or "out of active image area") conveyed as well by means of the Teletext service;
- new 16:9 receivers, complying with the present document, should be equipped with a Teletext decoder and always have the possibility of detecting the Teletext presence bit  $b_8$ .

---

## A.3 Procedure in absence of signalling

In the absence of signalling bits, the receiver should go to a default mode.

---

## Annex B (informative): Recommendations

### B.1 Low pass pre-filtering

It is recommended that the received status bit is low pass filtered before decoding.

This low pass filter should preserve the main spectral energy of the status bits signal, which resides in the spectral domain of 0 MHz up to 1,67 MHz.

---

### B.2 Response time on a change in the received signalling information

The maximum response time on a change in the received status bits signalling information is recommended to be: 120 ms.



---

## Annex C (informative): Guidelines

### C.1 Copyright information

The setting of data bit  $b_{13}$  to "0" does not mean that there are no constraints on the use of the programme material if copied (as is the case in the absence of signalling bits).

[b12b13] = [00] is identical to the absence of signalling bits (see clause A3).

## Annex D (informative): Future use of bit 7

Bit 7 is labelled as "reserved", with the instruction to set it to "0". In the future this bit could be used to convey a single-bit Boolean entity. However, once allocated in this way, no further enhancements or extensions would be possible. This annex describes how this single bit can be used to convey multi-bit values.

### Principles

The multi-bit data to be transmitted is sent bit-by-bit using bit 7 in successive instances of the WSS signal. A receiver interprets successive bit 7's as a serial data stream. This is decoded according to the application. Some bits could be defined for specific purposes; others could be reserved for future use.

In order for the receiver to determine the start and finish of a message within the bit 7 bit stream, additional Framing Bits have to be added to the start of each message. The sequence used must be unique. To guard against the possibility that sequences of data bits may themselves match the chosen framing code sequence, additional Protocol Bits have to intersperse with the data bits of the message at regular intervals.

A generic sequence is shown in figure D.1. Here the message to be sent is divided into N equal parts, each separated by a single Protocol Bit.

Framing Bits	Message Bits (part 1)	Protocol Bit	Message Bits (part 2)	Protocol Bit		Message Bits (part N)	Protocol Bit
--------------	--------------------------	--------------	--------------------------	--------------	--	--------------------------	--------------

**Figure D.1: Generic message sequence**

Assuming that a single bit is used for a Protocol Bit, the number of bits required in the Framing Code is given by the formula:

$$\text{No. of Framing Code bits} = \text{No. of Message Bits per unit part} + 2$$

Protection Bits to enable a receiver to identify, and possibly correct, transmission path induced errors can be appended to the sequence as thought necessary. Protocol Bits have to be inserted within multi-bit values. The simplest approach is to provide a parity check. In figure D.2, the last Protocol Bit of the generic message shown in figure D.1 has become a parity flag for the Message Bits. Although the parity bit can take either value, no ambiguity is introduced as the Framing Code of the next sequence will follow.

Framing Bits	Message Bits (part 1)	Protocol Bit	Message Bits (part 2)	Protocol Bit		Protocol Bit	Message Bits (part N)	Parity Flag
--------------	--------------------------	--------------	--------------------------	--------------	--	--------------	--------------------------	-------------

**Figure D.2: Generic message sequence with a parity bit**

### Static data

A multi-bit value is conveyed when the value of bit 7 is constantly changing. An application can also assign a meaning to static data, i.e. where the bit remains at "0" or at "1" either indefinitely or for a certain period of time.

### EXAMPLES:

The coding to transmit a single 2-bit value without added protection is shown in figure D.3. A Framing Code value of 110 has been chosen. Protocol Bits are not required as the Framing Code is longer than the message. A complete message is broadcast in 200 ms.

Framing code	Message Bits
1 1 0	M0 M1

**Figure D.3: Coding to transmit a single 2-bit value**

The coding to transmit two 3-bit values (X and Y), one 2-bit value (Z) plus a parity protection bit (P) is shown in figure D.4. The message data is divided into 2-bit units and a single Protocol Bit is used. Thus the Framing Code is required to have four bits and a value of 1110 has been chosen. The Protocol Bit inserted after a Message Bit unit is set to 0 to prevent the Framing Code from occurring elsewhere in the total sequence. A complete message is broadcast in 640 ms.

Framing code	Message Bits	Protocol Bit	Message Bits	Protocol Bit	Message Bits	Protocol Bit	Message Bits	Protection Bit
1 1 1 0	X0 X1	0	X2 Y0	0	Y1 Y2	0	Z0 Z1	P

**Figure D.4: Coding to transmit two 3-bit and one 2-bit values with parity protection**

---

## History

<b>Document history</b>		
Edition 1	November 1994	Publication as ETS 300 294
Edition 2	May 1996	Publication as ETS 300 294
Edition 3	September 1997	Publication as ETS 300 294
V1.3.2	April 1998	Publication
V1.4.1	December 2002	One-step Approval Procedure      OAP 20030411: 2002-12-11 to 2003-04-11