

**Integrated Services Digital Network (ISDN);
Conference call, add-on (CONF) supplementary service;
Digital Subscriber Signalling System No. one (DSS1) protocol;
Part 6: Abstract Test Suite (ATS) and partial Protocol
Implementation eXtra Information for Testing (PIXIT)
proforma specification for the network**



Reference

REN/SPS-05166-6 (1ppi0j1c.PDF)

Keywords

ISDN, DSS1, supplementary service, CONF,
testing, ATS, PIXIT, network

ETSI

Postal address

F-06921 Sophia Antipolis Cedex - FRANCE

Office address

650 Route des Lucioles - Sophia Antipolis
Valbonne - FRANCE
Tel.: +33 4 92 94 42 00 Fax: +33 4 93 65 47 16
Siret N° 348 623 562 00017 - NAF 742 C
Association à but non lucratif enregistrée à la
Sous-Préfecture de Grasse (06) N° 7803/88

Internet

secretariat@etsi.fr
Individual copies of this ETSI deliverable
can be downloaded from
<http://www.etsi.org>

Copyright Notification

No part may be reproduced except as authorized by written permission.
The copyright and the foregoing restriction extend to reproduction in all media.

© European Telecommunications Standards Institute 1998.
All rights reserved.

Contents

Intellectual Property Rights.....	5
Foreword.....	5
1 Scope	5
2 References	6
3 Definitions and abbreviations	7
3.1 Definitions	7
3.2 Abbreviations	7
4 Abstract Test Method (ATM).....	8
4.1 Description of ATM used	8
4.1.1 Conventions for test components and PCOs	8
4.1.2 Conventions for variables and parameters	9
4.1.3 Special conventions for the CONF supplementary service.....	10
4.1.4 Conventions for the remote user group	10
4.2 Alternative ATM.....	11
5 Untestable test purposes	12
6 ATS conventions	12
6.1 Declarations part.....	12
6.1.1 Type definitions.....	12
6.1.1.1 Simple type definitions	12
6.1.1.2 Structured type definitions	12
6.1.1.2.1 TTCN structured type definitions.....	12
6.1.1.2.2 ASN.1 structured type definitions	12
6.1.1.3 ASP type definitions	13
6.1.1.3.1 TTCN ASP type definitions	13
6.1.1.3.2 ASN.1 ASP type definitions.....	14
6.1.1.4 PDU type definitions.....	14
6.1.1.4.1 TTCN PDU type definitions.....	14
6.1.1.4.2 ASN.1 PDU type definitions	14
6.1.2 Test suite constants.....	14
6.1.3 Test suite parameters.....	14
6.1.4 Variables	14
6.1.4.1 Test suite variables.....	14
6.1.4.2 Test case variables	14
6.1.5 Test suite operation definitions	14
6.2 Constraints part.....	15
6.2.1 Structured type constraint declaration	15
6.2.2 ASN.1 type constraint declaration.....	15
6.2.2.1 Specification of encoding rules	16
6.2.3 ASP type constraint declaration	17
6.2.3.1 ASN.1 ASP type constraint declaration.....	17
6.2.3.2 TTCN ASP type constraint declaration	17
6.2.4 PDU type constraint declaration.....	17
6.2.4.1 ASN.1 PDU type constraint declaration	17
6.2.4.2 TTCN PDU type constraint declaration.....	17
6.2.5 Chaining of constraints	17
6.2.5.1 Static chaining	17
6.2.5.2 Dynamic chaining	17
6.2.6 Derived constraints	18
6.2.7 Parameterized constraints.....	18
6.2.8 Value assignment.....	18
6.2.8.1 Specific values	18
6.2.8.2 Matching values.....	18
6.3 Dynamic part.....	18

6.3.1	Test cases	18
6.3.2	Test steps.....	18
6.3.2.1	PTC1_IN	18
6.3.2.2	PTC1_OUT.....	19
6.3.3	Defaults	19
7	ATS to TP map	19
8	PCTR conformance	19
9	PIXIT conformance.....	19
10	ATS conformance.....	20
Annex A (normative): Protocol Conformance Test Report (PCTR) proforma		21
A.1	Identification summary.....	21
A.1.1	Protocol conformance test report	21
A.1.2	IUT identification.....	21
A.1.3	Testing environment	22
A.1.4	Limits and reservations	22
A.1.5	Comments.....	22
A.2	IUT conformance status	22
A.3	Static conformance summary	22
A.4	Dynamic conformance summary	23
A.5	Static conformance review report.....	23
A.6	Test campaign report	24
A.7	Observations	25
Annex B (normative): Partial PIXIT proforma		26
B.1	Identification summary.....	26
B.2	Abstract test suite summary	26
B.3	Test laboratory.....	26
B.4	Client (of the test laboratory).....	27
B.5	System Under Test (SUT).....	27
B.6	Protocol information	28
B.6.1	Protocol identification	28
B.6.2	Parameter values.....	28
B.6.3	Codings of information elements.....	28
B.6.4	Configuration of IUT.....	29
B.6.5	Timer values	29
B.7	Basic call PIXIT items	29
B.7.1	Parameter values - information element codings.....	30
Annex C (normative): Abstract Test Suite (ATS).....		31
C.1	The TTCN Graphical form (TTCN.GR)	31
C.2	The TTCN Machine Processable form (TTCN.MP).....	31
Annex D (informative): General structure of ATS		32
Annex E (informative): Changes with respect to the previous ETS 300 185-6.....		33
History.....		34

Intellectual Property Rights

IPRs essential or potentially essential to the present document may have been declared to ETSI. The information pertaining to these essential IPRs, if any, is publicly available for **ETSI members and non-members**, and can be found in SR 000 314: "*Intellectual Property Rights (IPRs); Essential, or potentially Essential, IPRs notified to ETSI in respect of ETSI standards*", which is available **free of charge** from the ETSI Secretariat. Latest updates are available on the ETSI Web server (<http://www.etsi.org/ipr>).

Pursuant to the ETSI IPR Policy, no investigation, including IPR searches, has been carried out by ETSI. No guarantee can be given as to the existence of other IPRs not referenced in SR 000 314 (or the updates on the ETSI Web server) which are, or may be, or may become, essential to the present document.

Foreword

This European Standard (Telecommunications series) has been produced by ETSI Technical Committee Signalling Protocols and Switching (SPS), and is now submitted for the Public Enquiry phase of the ETSI standards Two-step Approval Procedure.

The present document is part 6 of a multi-part standard covering the Digital Subscriber Signalling System No. one (DSS1) protocol specification for the Integrated Services Digital Network (ISDN) Conference call, add-on (CONF) supplementary service, as described below:

- Part 1: "Protocol specification";
- Part 2: "Protocol Implementation Conformance Statement (PICS) proforma specification";
- Part 3: "Test Suite Structure and Test Purposes (TSS&TP) specification for the user";
- Part 4: "Abstract Test Suite (ATS) and partial Protocol Implementation eXtra Information for Testing (PIXIT) proforma specification for the user";
- Part 5: "Test Suite Structure and Test Purposes (TSS&TP) specification for the network";
- Part 6: "Abstract Test Suite (ATS) and partial Protocol Implementation eXtra Information for Testing (PIXIT) proforma specification for the network".**

The present version updates the references to the basic call specifications.

Proposed national transposition dates	
Date of latest announcement of this EN (doa):	3 months after ETSI publication
Date of latest publication of new National Standard or endorsement of this EN (dop/e):	6 months after doa
Date of withdrawal of any conflicting National Standard (dow):	6 months after doa

1 Scope

This sixth part of EN 300 185 specifies the Abstract Test Suite (ATS) and partial Protocol Implementation eXtra Information for Testing (PIXIT) proforma for the Network side of the T reference point or coincident S and T reference point (as defined in ITU-T Recommendation I.411 [11]) of implementations conforming to the stage three standard for the Conference call, add-on (CONF) supplementary service for the pan-European Integrated Services Digital Network (ISDN) by means of the Digital Subscriber Signalling System No. one (DSS1) protocol, EN 300 185-1 [2].

EN 300 185-5 [4] specifies the Test Suite Structure and Test Purposes (TSS&TP) related to this ATS and partial PIXIT proforma specification. Other parts specify the TSS&TP and the ATS and partial PIXIT proforma for the User side of the T reference point or coincident S and T reference point of implementations conforming to EN 300 185-1 [2].

2 References

The following documents contain provisions which, through reference in this text, constitute provisions of the present document.

- References are either specific (identified by date of publication, edition number, version number, etc.) or non-specific.
- For a specific reference, subsequent revisions do not apply.
- For a non-specific reference, the latest version applies.
- A non-specific reference to an ETS shall also be taken to refer to later versions published as an EN with the same number.

- [1] EN 300 403-1: "Integrated Services Digital Network (ISDN); Digital Subscriber Signalling System No. one (DSS1) protocol; Signalling network layer for circuit-mode basic call control; Part 1: Protocol specification [ITU-T Recommendation Q.931 (1993), modified]".
- [2] EN 300 185-1 (V1.2): "Integrated Services Digital Network (ISDN); Conference call, add-on (CONF) supplementary service; Digital Subscriber Signalling System No. one (DSS1) protocol; Part 1: Protocol specification".
- [3] EN 300 185-2 (V1.2): "Integrated Services Digital Network (ISDN); Conference call, add-on (CONF) supplementary service; Digital Subscriber Signalling System No. one (DSS1) protocol; Part 2: Protocol Implementation Conformance Statement (PICS) proforma specification".
- [4] EN 300 185-5 (V1.2): "Integrated Services Digital Network (ISDN); Conference call, add-on (CONF) supplementary service; Digital Subscriber Signalling System No. one (DSS1) protocol; Part 5: Test Suite Structure and Test Purposes (TSS&TP) specification for the network".
- [5] EN 300 196-1: "Integrated Services Digital Network (ISDN); Generic functional protocol for the support of supplementary services; Digital Subscriber Signalling System No. one (DSS1) protocol; Part 1: Protocol specification".
- [6] ISO/IEC 9646-1: "Information technology - Open Systems Interconnection - Conformance testing methodology and framework - Part 1: General concepts".
- [7] ISO/IEC 9646-2: "Information technology - Open Systems Interconnection - Conformance testing methodology and framework - Part 2: Abstract Test Suite specification".
- [8] ISO/IEC 9646-3: "Information technology - Open Systems Interconnection - Conformance testing methodology and framework - Part 3: The Tree and Tabular Combined Notation (TTCN)".
- [9] ISO/IEC 9646-4: "Information technology - Open Systems Interconnection - Conformance testing methodology and framework - Part 4: Test realization".
- [10] ISO/IEC 9646-5: "Information technology - Open Systems Interconnection - Conformance testing methodology and framework - Part 5: Requirements on test laboratories and clients for the conformance assessment process".
- [11] ITU-T Recommendation I.411 (1993): "ISDN user-network interfaces - Reference configurations".
- [12] CCITT Recommendation X.209 (1988): "Specification of Basic Encoding Rules for Abstract Syntax Notation One (ASN.1)".

3 Definitions and abbreviations

3.1 Definitions

For the purposes of the present document, the following definitions apply:

Abstract Test Suite (ATS): See ISO/IEC 9646-1 [6].

Implementation Under Test (IUT): See ISO/IEC 9646-1 [6].

Lower Tester (LT): See ISO/IEC 9646-1 [6].

Point of Control and Observation (PCO): See ISO/IEC 9646-1 [6].

Protocol Implementation Conformance Statement (PICS): See ISO/IEC 9646-1 [6].

PICS proforma: See ISO/IEC 9646-1 [6].

Protocol Implementation Extra Information for Testing (PIXIT): See ISO/IEC 9646-1 [6].

PIXIT proforma: See ISO/IEC 9646-1 [6].

System Under Test (SUT): See ISO/IEC 9646-1 [6].

Upper Tester (UT): See ISO/IEC 9646-1 [6].

3.2 Abbreviations

For the purposes of the present document, the following abbreviations apply:

ASP	Abstract Service Primitive
ATM	Abstract Test Method
ATS	Abstract Test Suite
BER	Basic Encoding Rules
CM	Co-ordination Message
CONF	Conference call, add-on
CP	Co-ordination Point
DSS1	Digital Subscriber Signalling System No. one
ExTS	Executable Test Suite
ISDN	Integrated Services Digital Network
IUT	Implementation Under Test
LT	Lower Tester
MOT	Means Of Testing
MTC	Main Test Component
PCO	Point of Control and Observation
PCTR	Protocol Conformance Test Report
PDU	Protocol Data Unit
PICS	Protocol Implementation Conformance Statement
PIXIT	Protocol Implementation eXtra Information for Testing
PTC	Parallel Test Component
SUT	System Under Test
TCP	Test Co-ordination Procedures
TP	Test Purpose
TSS&TP	Test Suite Structure and Test Purposes
TTCN	Tree and Tabular Combined Notation
UT	Upper Tester

4 Abstract Test Method (ATM)

4.1 Description of ATM used

The requirement for testing the network Implementation Under Test (IUT) is to focus on the behaviour of the network IUT at the user-network interface where a T reference point or coincident S and T reference point applies. Thus the IUT is the network DSS1 protocol entity at a particular user-network interface and is not the whole network.

It is possible to specify an ATS based on a Single party (remote) test method for such an IUT. However, it is considered that an ATS based on such an approach is of limited use as the only way to specify IUT generated PDUs is to use the "implicit send" statement. Many users of such an ATS would replace the "implicit send" statements with descriptions of the behaviour at other interfaces.

An ATS based on a multi-party test method is considered to be more useful in that it is closer to how a real test suite would be constructed. Such a test method specifies behaviour at multiple network interfaces. One very important limitation here is that tests are focused on one particular interface. Thus the test system is made up one Main Test Component (MTC) and one or more Parallel Test Components (PTC), see figure 1.

4.1.1 Conventions for test components and PCOs

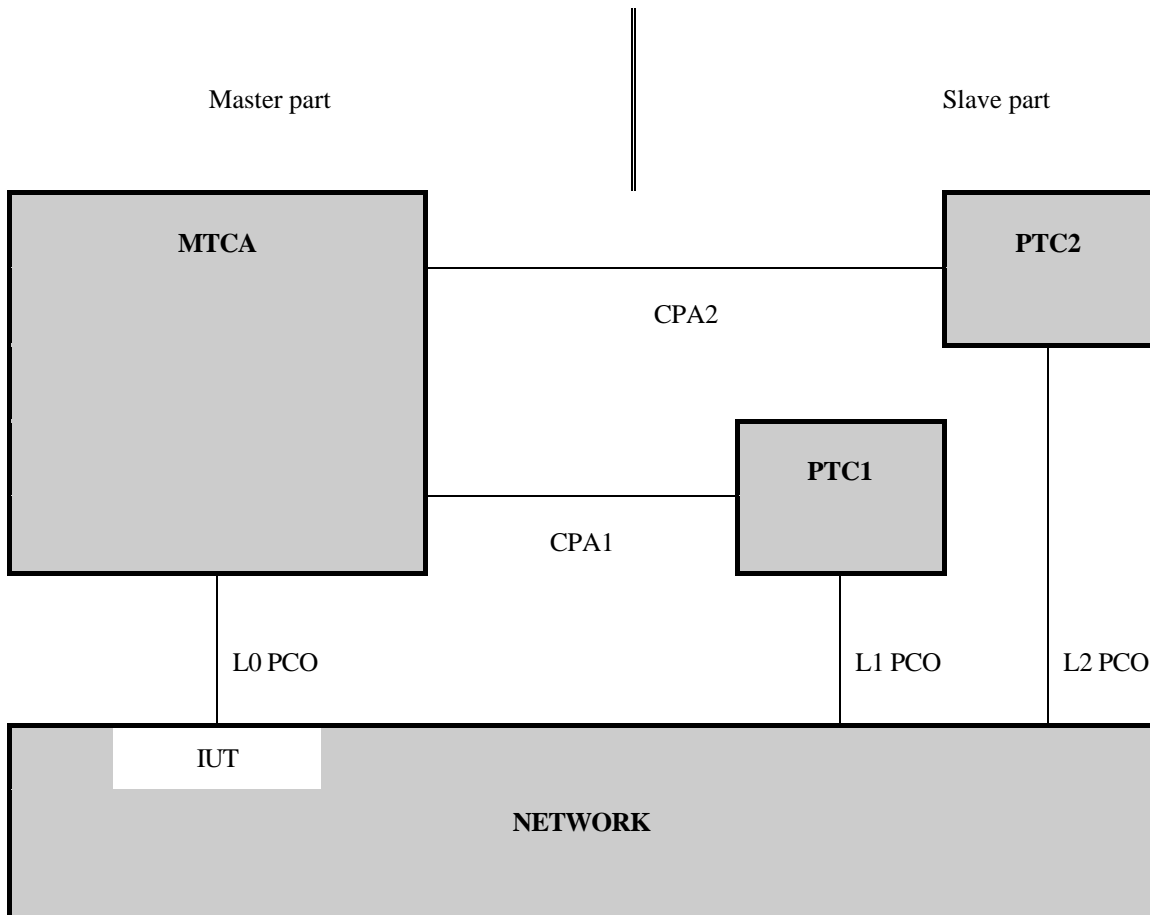

Figure 1: Multi-party test method

In a master/slave arrangement, the MTC is considered to be the master while the PTCs are the slaves. The "slave" testers are only an explicit description of how to deal with the "other" interfaces during the testing process, i.e. "how to make the IUT send the required message".

This means, in particular, that the verdict will only be assigned from the protocol aspects observed on the interface under test (i.e. by the "master" tester), as it would be observed by a terminal connected to this interface. A failure in the correlation between the protocol at the different interfaces to which the different testers are connected, i.e. in the

mechanism of the functional service itself, will not cause a FAIL verdict. For instance, if the IUT fails to send a message on the tested interface after another interface has received the proper stimulus, the verdict will be INCONCLUSIVE.

The MTC MTCA has two functions in this configuration. Firstly, it has the MTC function of controlling the one or more PTCs. Thus it is responsible for starting the PTCs and afterwards co-ordinates activities by exchanging Co-ordination Messages (CM) with the PTCs. Secondly it is responsible for the behaviour of the Lower Tester (LT) at Point of Control and Observation (PCO) L0.

A combination of the remote and multi-party test methods is applied. As can be seen from figure 1, several PCOs are used. All PCOs reside at the service access points between layers 2 and 3.

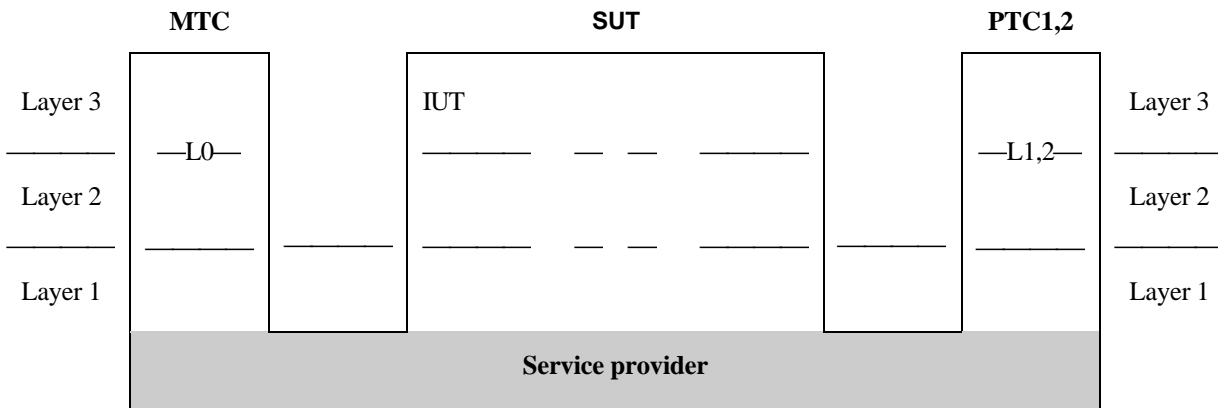

Figure 2: Combination of the remote and multi-party test methods

The MTC PCO is named "L0" ("L" for Lower). The L0 PCO is used to control and observe the behaviour of the IUT and test case verdicts are assigned depending on the behaviour observed at this PCO. The PTCs PTC1, PTC2 etc. use PCOs L1, L2 etc. These PCOs are used to control and, in a limited way, observe the behaviour of the network equipment at interfaces other than the one under test. No verdicts are assigned at these PCOs.

As stated in a previous paragraph, the non-receipt of network generated messages at L0, which are stimulated by events at the L1, L2 etc., will result in INCONCLUSIVE rather than FAIL verdicts being assigned.

4.1.2 Conventions for variables and parameters

MTCA

call reference	CREF1	(to PTC1)
B channel (basic)	bch_num1	
channel nr (primary)	CH_NUM1	

call reference	CREF2	(to PTC2)
B channel (basic)	bch_num2	
channel nr (primary)	CH_NUM2	

PCO L0	IPN0, LIPN0
--------	-------------

PTC1

call reference	P1CREF
B channel (basic)	P1_bch_num
channel nr (primary)	P1_CH_NUM

PCO L1	IPN1, LIPN1
--------	-------------

PTC2

call reference	P2CREF
B channel (basic)	P2_bch_num
channel nr (primary)	P2_CH_NUM

PCO L2	IPN2, LIPN2
--------	-------------

4.1.3 Special conventions for the CONF supplementary service

To begin a conference from the Null Call State, a remote user is not required. The CREF1 will be used without the PTC1. To add a party to the conference, a remote user with CREF2 using PTC2 is called.

Some remote user test cases use 2 parties. To do that the first party is added by using the CREF2 with PTC1. After the party has been added to the conference, CREF2 will be released. Then it is possible to add the second party by using CREF2 with PTC2.

4.1.4 Conventions for the remote user group

For this group, the side of the network which is being tested is where the conference remote user is connected. The most convenient approach here is to connect PTC1 to the IUT. The MTC is, as for the served user group test cases, connected at the served user side of the network. This approach allows the re-use of test steps developed for the served user group tests. This approach, representing a slight modification in the test method, is illustrated in figure 3. This shows that the part of the network considered to be the IUT is connected to PTC1 rather than MTC1.

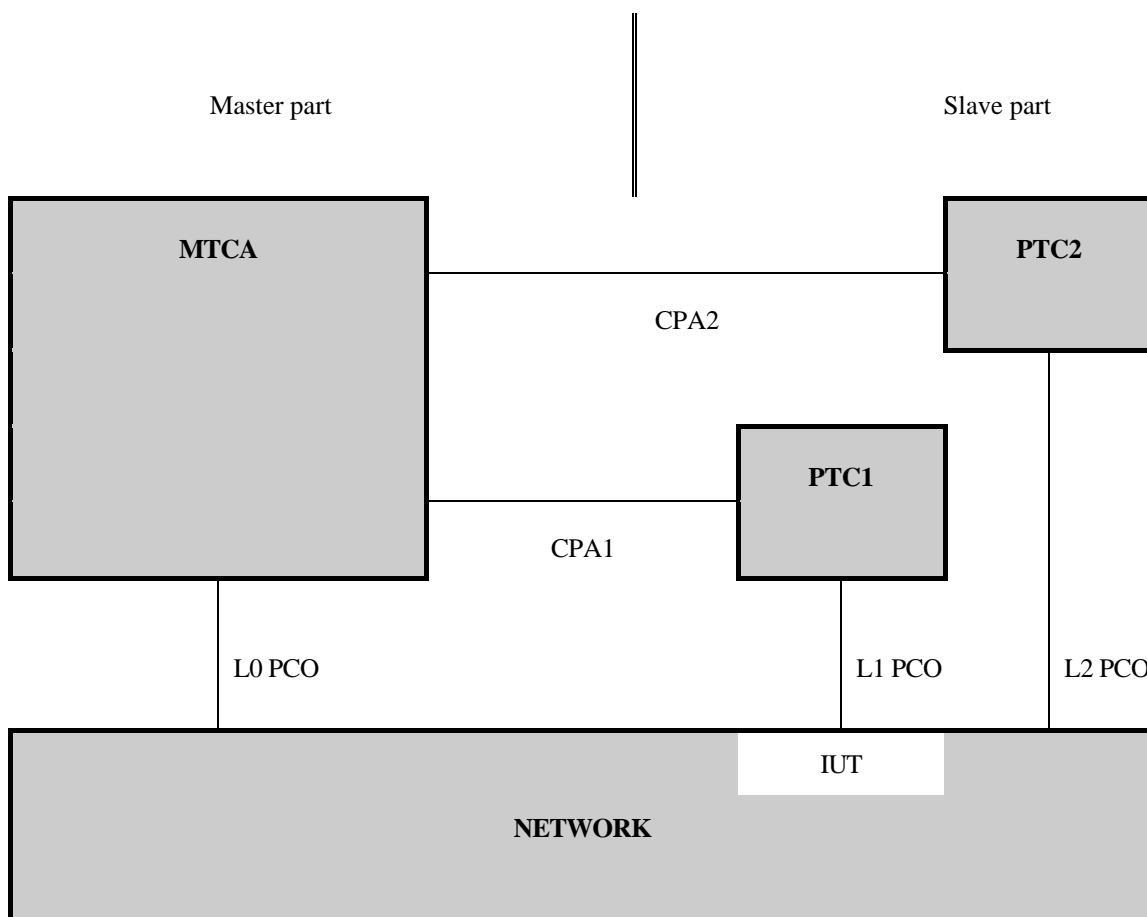

Figure 3: Multi-party test method - modified for remote user tests

The PTC1 is used to observe the notifications sent by the network. The test step PTC1_remoteUser_CR1 is used to check the receipt of the notification and depending on the result sends a CM back to the MTC. The MTC then issues a verdict depending on the CM received from the PTC1. This is done in order to maintain the convention that the MTC is only allowed to issue verdicts. However, one consequence of this is that any behaviour at the served user side which is non-conforming will result in a Fail verdict being issued even though the focus of the tests is at the remote user side. This constraint is viewed as acceptable given the fact that in any case the network shall provide a conforming served user interface as well as one or more conforming remote user interfaces.

4.2 Alternative ATM

As stated in subclause 4.1, an ATS based on a single-party (remote) ATM is possible. Such an ATS may be generated from the one specified in the present document. The following general steps should be taken:

- 1) remove all PTC behaviour;
- 2) remove all CREATE statements;
- 3) replace CMs which are used to provoke PDUs at the MTC, with implicit send statements.

An example, showing the difference between the multi-party ATM and single-party ATM for a single test case, is given in tables 1 and 2.

Table 1: Test case dynamic behaviour table using multi-party ATM

TEST CASE DYNAMIC BEHAVIOUR				
Test Case Name	HOLD_N04_001			
Group	RemoteUser_ST_OR_T/Holding/			
Purpose	Ensure that the IUT, while in the Active call state N10, to notify the non-served user that the call is held			
Default Configuration	DF69901(1)			
Comments	9.2.1 valid optional			
Nr	Label	BEHAVIOUR DESCRIPTION	CREF	V
1	CREATE (PTC1: PTC1_IN_servedUser)			
2	+PR31002			preamble N10
3	CPA1!CP_M START TWAIT	S_HL		
4	L0?NOTIFYr	A_NO20(CREF1,hold_NID)	(P)	check N10
5	+CS59901(10,1)			
6	?TIMEOUT TWAIT		(I)	
7	+PO49901(1)			postamble N0
DETAILED COMMENTS:				

Table 2: Test case dynamic behaviour table using single-party ATM

TEST CASE DYNAMIC BEHAVIOUR				
Test Case Name	HOLD_N04_001			
Group	RemoteUser_ST_OR_T/Holding/			
Purpose	Ensure that the IUT, while in the Active call state N10, to notify the non-served user that the call is held			
Default Configuration	DF69901(1)			
Comments	9.2.1 valid optional			
Nr	Label	BEHAVIOUR DESCRIPTION	CREF	V
1	+PR31002			preamble N10
2	<IUT!NOTIFY>	NO20(CREF1,hold_NID)		
3	L0?NOTIFYr	A_NO20(CREF1,hold_NID)	(P)	check N10
4	+CS59901(10,1)			
5	?TIMEOUT TWAIT		(I)	
6	+PO49901(1)			postamble N0
DETAILED COMMENTS:				

5 Untestable test purposes

There are no untestable test cases associated with this ATS and ATM.

6 ATS conventions

This clause is structured similarly to the structure of a Tree and Tabular Combined Notation (TTCN) ATS. However, the names of the subclauses are arranged in a way more suitable to the present document.

6.1 Declarations part

6.1.1 Type definitions

6.1.1.1 Simple type definitions

Where appropriate, simple types have a length, a value list or a range restriction attached.

Simple types defined as being of some string type (e.g. BIT STRING, OCTET STRING), have a length restriction or a value list attached.

Simple types, defined as being of INTEGER type, have a value list or a range restriction attached.

6.1.1.2 Structured type definitions

6.1.1.2.1 TTCN structured type definitions

All structured type definitions are provided with a full name.

All elements in every structured type definition, defined as being of some string type (e.g. BIT STRING, OCTET STRING), have a length restriction attached.

If an element in a structured type definition is defined as being of a referenced type, the (possible) restriction is defined in that referenced type.

For information elements the identifier, which is unique for each element, has its type defined as a simple type where the value list is restricted to the single value which is the identifier itself. This has the advantage that it allows a test system derived from this ATS to easily identify information elements embedded in messages. An ATS where information element identifiers are represented as unrestricted types can present difficulties for a derived test system in the case where it needs to find one information element embedded in a number of others and the constraints for the other elements have the any-or-omit value. In such a case the test system cannot easily find the beginning of each information element.

6.1.1.2.2 ASN.1 structured type definitions

ASN.1 has been used for three major reasons. First, types defined in ASN.1 can model problems that "pure" TTCN cannot. For instance, data structures modelling ordered or unordered sequences of data are preferably defined in ASN.1. Second, ASN.1 provides a better restriction mechanism for type definitions by using sub-type definitions. Third, it is necessary to use ASN.1 to reproduce the type definitions for remote operation components as specified in the base standards.

The fact that ASN.1 provides a better restriction mechanism for type definitions is used for the purpose of achieving type-compatibility.

Tables 3 and 4 show the typical use of ASN.1. The FIE type in table 3 is written in ASN.1 to permit the use of the SET OF construction in the components field. Constraints of the FIE type can therefore be written using the SUPERSET function which allows to match a single component which may be delivered together with a set of other components. Table 4 shows the reject component type which is defined following the ASN.1 declaration in EN 300 196-1 [5].

Table 3: ASN.1 type definition FIE

ASN.1 Type Definition	
Type Name :	FIE
Comments :	Facility information element taken from EN 300 196; 11.2.2.1. Specified here for both send & receive event.
Type Definition	
SEQUENCE {	
informationElementIdentifier	FIE_I,
length	FIE_LengthType,
extBit	BIT STRING (SIZE (1)),
spareBits	BIT STRING (SIZE (2)),
protocolProfile	BIT STRING (SIZE (5)),
components	SET OF Component }

Table 4: ASN.1 type definition RejectComponent

ASN.1 Type Definition	
Type Name :	RejectComponent
Comments :	Reject Component is not specific to any particular operation. The invokeID may be used to identify a specific operation.
Type Definition	
SEQUENCE {	
invokeID CHOICE {	
invokeID	InvokeIDType,
null	NULL },
problem CHOICE {	
generalProblem	[0] IMPLICIT GeneralProblem,
invokeProblem	[1] IMPLICIT InvokeProblem,
returnResultProblem	[2] IMPLICIT ReturnResultProblem,
returnErrorProblem	[3] IMPLICIT ReturnErrorProblem }

Table 5 shows an example of how ASN.1 can be used to model unordered sequences.

Table 5: ASN.1 type definition FIES

ASN.1 Type Definition	
Type Name :	FIES
Comments :	
Type Definition	
SET OF FIE	

The possibility to use TTCN and ASN.1 in combination is used, i.e. referring to an ASN.1 type from a TTCN type.

6.1.1.3 ASP type definitions

6.1.1.3.1 TTCN ASP type definitions

TTCN Abstract Service Primitive (ASP) type definitions only contain one Protocol Data Unit (PDU) or no PDU at all. The relationship between an ASP type and a PDU type is one-to-one. That is, there exists one ASP type definition for each PDU type definition (if that ASP type contains a PDU).

All TTCN ASP type definitions are provided with a full identifier.

Some ASPs are not parameterized as shown in the example in table 6. Such ASPs are only used for requesting or receiving service from the lower layer.

Table 6: TTCN ASP type definition DL_REL_IN

TTCN ASP Type Definition		
ASP NAME : DL_REL_IN(DL_RELEASE_INDICATION)		
PCO Type : SAP		
Comments :		
Parameter Name	Parameter Type	Comments
Detailed Comments :		

Table 7 shows an example of a parameterized ASP. All ASPs containing PDUs contain only that PDU and no other parameters.

Table 7: TTCN ASP type definition DL_DATA_RQ_ALERT

TTCN ASP Type Definition		
ASP NAME : DL_DATA_RQ_ALERT(DL_DATA_REQUEST)		
PCO Type : SAP		
Comments :		
Parameter Name	Parameter Type	Comments
mun (MessageUnit)	ALERT_PDU	
Detailed Comments :		

6.1.1.3.2 ASN.1 ASP type definitions

There are no ASN.1 ASP type definitions in the ATS.

6.1.1.4 PDU type definitions

6.1.1.4.1 TTCN PDU type definitions

The TTCN PDU type reflects the actual data being transferred or received. All PDUs are embedded in ASPs.

If a specific PDU type definition contains elements defined in terms of a pre-defined type, that element has a restriction attached to it.

6.1.1.4.2 ASN.1 PDU type definitions

There are no ASN.1 PDU type definitions in the ATS.

6.1.2 Test suite constants

No test suite constants are used or defined in this ATS.

6.1.3 Test suite parameters

Each test suite parameter is defined in terms of a predefined type or a referenced type. A referenced type is used when it is necessary to attach restrictions to these type definitions (it is not allowed to include restrictions directly in the test suite parameter table). The referenced type can have a length or value restriction attached to it in its declaration table.

6.1.4 Variables

6.1.4.1 Test suite variables

No test suite variables are used or defined in this ATS.

6.1.4.2 Test case variables

Each test case variable is defined in terms of a predefined type or a referenced type. A referenced type is used when it is necessary to attach restrictions to these type definitions (it is not allowed to include restrictions directly in the test case variable table). The referenced type can have a length or value restriction attached to it in its declaration table.

Where test case variables are used in constraints, they are passed as formal parameters.

6.1.5 Test suite operation definitions

The description part of a test suite operation definition uses either natural language or meta C.

Table 8: Test suite operation definition ASSIGN_CHI

Test Suite Operation Definition	
Operation Name	: ASSIGN_CHI(basic, primary : CHI; basic_flag : BOOLEAN)
Result Type	: CHI
Comments	: This operation is used to assign a correct Channel identification information element to PDUs dependent on the type of access that is tested.
Description	
<pre> { if(basic_flag) return basic; else return primary } </pre>	
Detailed comments	:

The test suite operation definition shown in table 8 is used in the constraints part when assigning an element of type CHI a value. As previously described, the CHI type can be defined in two ways depending on whether the ATS is testing basic or primary rate access. This operation is used to assign a value to an element of CHI type. It takes three parameters:

```

primary:   a constraint of type CHI valid for primary rate access;
basic:     a constraint of type CHI valid for basic access;
basic_flag: a Boolean value: TRUE if basic access is applicable, FALSE otherwise.

```

This operation returns the correct constraint according to the Boolean flag basic_flag. That constraint will then be assigned to the specific element of type CHI.

6.2 Constraints part

6.2.1 Structured type constraint declaration

For every structured type definition there exists one or more structured type constraint.

6.2.2 ASN.1 type constraint declaration

Constraints of this type are used to assign the corresponding type a specific value. These constraints are used for the purpose of modelling unordered data or specific types that cannot be expressed in TTCN.

A value assigned to an element of type SET OF differs depending on whether it is a send or receive constraint.

Table 9: ASN.1 type constraint declaration FIEs (send constraint)

ASN.1 Type Constraint Declaration	
Constraint Name	: FIEs(comp : Component)
ASN.1 Type	: FIE
Derivation Path	:
Comments	: Send FIE which will contain one component "comp".
Description	
<pre> { informationElementIdentifier '00011100'B, length CALC_FIE_LENGTH(comp), extBit '1'B, spareBits '00'B, protocolProfile '10001'B, components {comp} } </pre>	
Detailed comments	:

NOTE: The last element in the constraint, *components*, is of type *SET OF Component* where *Component* is structured data of some type.

If the constraint is a send constraint (as in table 9) the value for the component element is stated as "{comp}" where comp is an argument received as a parameter. The "{" and "}" turns the value into a SET OF value which is correct according to that element's type definition.

Table 10: ASN.1 type constraint declaration fIEr (receive constraint)

ASN.1 Type Constraint Declaration	
Constraint Name	: fIEr(comp : Component)
ASN.1 Type	: FIE
Derivation Path	:
Comments	: A received FIE which can contain several components, but which contains at least "comp".
Description	
{	
informationElementIdentifier	'00011100'B,
length	'???????'B,
extBit	'1'B,
spareBits	'00'B,
protocolProfile	'10001'B,
components	SUPERSET({comp})
}	
Detailed comments	:

NOTE: The last element in the constraint, named *components*, is of type *SET OF Component* where *Component* is structured data of some type.

If the constraint is a receive constraint (as in table 10) the corresponding matching value is assigned by using SUPERSET. The key-word SUPERSET has an argument that is type compatible with the type definition of that field. In table 10, the element named *components* is defined as "SET OF Component" and this implies that the argument to SUPERSET should be of type SET OF Component. This is achieved the same way as for send constraints, enclosing the value in curly brackets.

The semantic of SUPERSET is stated in ISO/IEC 9646-3 [8], subclause 11.6.4.7. In short it defines the semantic as follows: "A value that uses SUPERSET matches the incoming value if, and only if, the incoming value contains **at least all of the elements** defined within the SUPERSET, and **may contain more elements**." This is exactly the semantic definition used in this ATS.

6.2.2.1 Specification of encoding rules

At the time of specifying this ATS the mechanisms related to encoding of ASN.1 types, specified in DAM-2 of ISO/IEC 9646-3 [8], were not yet stable. Nevertheless as there is a variation in the encoding rules as applied to ASN.1 types and constraints specified in this ATS, a mechanism is used to differentiate the different encoding rules. Given the non-finalized status of DAM-2, a solution which is broadly in the spirit of DAM-2 has been created. Comment fields have been used as a means of including the encoding rules.

For ASN.1 used in this ATS, two variations of encoding rules are used. One is the commonly known Basic Encoding Rules (BER) as specified in CCITT Recommendation X.209 [12]. In the second case the encoding is according to ISDN, i.e. the ASN.1 data types are a representation of structures contained within the ISDN specification (basic call, Generic functional protocol or individual supplementary service). For example, if octets of an information element are specified in ASN.1 as a SEQUENCE then this should be encoded in an Executable Test Suite (ExTS) as any other ISDN information element specified using tabular TTCN. This ISDN encoding variation is the default encoding rule for this ATS. This means that all ASN.1 constraint tables are encoded using ISDN (non-BER) encoding unless stated otherwise. BER encoding should never be applied to an ASN.1 constraint where BER encoding has not been specified.

For BER encoding, an indication is given in the comments field of the table header. For this ATS such indications appear in the ASN.1 type constraint declaration tables only. In the first line of the table header comment field, the notation "ASN1_Encoding: *BER*" is used.

Note that within BER, there are a number of variations for the encoding of lengths of fields. According to EN 300 196-1 [5], an IUT should be able to interpret all length forms within BER for received PDUs. When sending PDUs containing BER encoding, EN 300 196-1 [5] gives guidelines but makes no restrictions on the length forms within BER which an IUT may apply.

In relation to components sent by the tester to the IUT, implementors of this ATS shall use a variety of length forms such that at least one of each of the length forms is sent to the IUT during a test campaign. The variations of length forms to be used are indefinite, short definite and long definite.

In this particular ATS all ASN.1 type constraints which are of type "Component" are to be encoded using BER.

Table 11: ASN.1 type constraint declaration showing use of encoding variation

ASN.1 Type Constraint Declaration	
Constraint Name :	Beg3PTYinv
ASN.1 Type :	Component
Derivation Path :	
Comments :	ASN1_Encoding: BER Receive component: Begin3PTY invoke component
Description	
begin3PTY_Components begin3PTY_InvokeComp { invokeID ? , operation_value localValue 4 }	
Detailed comments :	

6.2.3 ASP type constraint declaration

6.2.3.1 ASN.1 ASP type constraint declaration

No ASN.1 ASP type constraint declaration exists in this ATS.

6.2.3.2 TTCN ASP type constraint declaration

For TTCN ASP constraint declarations there is a one-to-one relationship between its type and the constraint. That is, there is only one constraint for each TTCN ASP Type Declaration. The reason for this is that the ASPs are used only for carrying a specific PDU value. The many ASP constraints (and types) could have been avoided by using the meta type **PDU**, but that was not suitable as values inside a specific PDU have to be referenced. To reference elements inside a value of meta type **PDU** is not allowed according to ISO/IEC 9646-3 [8], so each ASP has to be defined as having a parameter of a specific PDU type.

In all ASP constraints the embedded PDU constraint is either chained static or "semi-dynamic". That is, the PDU constraint is always fixed to a specific ASP constraint but it (the PDU) may be parameterized.

All ASP constraints have a specific value for its parameter. No matching symbols are used in ASPs.

6.2.4 PDU type constraint declaration

6.2.4.1 ASN.1 PDU type constraint declaration

No ASN.1 PDU type constraint declaration exists in this ATS.

6.2.4.2 TTCN PDU type constraint declaration

PDU constraints are used for assigning values or patterns to the data being sent or received.

6.2.5 Chaining of constraints

6.2.5.1 Static chaining

Static chaining, that is a fixed reference to a specific constraint, is used in this ATS. The static chaining is used for static binding of both variables and sub-structures.

6.2.5.2 Dynamic chaining

Dynamic chaining is achieved when having a reference to a value which is unknown. The only thing known (before run-time) is the type of that reference. The reference is passed as a parameter. Strict dynamic chaining is not used in this ATS. What is used is something that is called "semi-dynamic chaining". The definition of semi-dynamic chaining is that the fixed reference is parameterized with an unknown value. That value is received as a parameter.

Table 12: TTCN ASP constraint declaration A_RST1

TTCN ASP Constraint Declaration		
Constraint Name : A_RST1 (FLAG : INTEGER)		
ASN.1 Type : DL_DAT_IN_RESTARTr		
Derivation Path :		
Comments :		
Parameter Name	Parameter Value	Comments
mun	RST1 (FLAG)	RST1 (FLAG)
Detailed comments :		

Table 12 is an example of semi-dynamic chaining. The TTCN ASP constraint is parameterized with an INTEGER value named FLAG. That value is passed further down in the structure as a parameter to a static named PDU constraint reference.

6.2.6 Derived constraints

No derivation of any constraint is used. All constraints are considered to be base constraints.

6.2.7 Parameterized constraints

Parameterized constraints are used in this ATS.

6.2.8 Value assignment

6.2.8.1 Specific values

For specific value assignment both explicit values and references to explicit values are used.

6.2.8.2 Matching values

As matching values the following mechanisms are used:

Instead of Value:

AnyOrOmit	"*"
AnyValue	"?"
Omit	"_"

Inside value:

AnyOne	"?"
AnyOrNone	"*"

6.3 Dynamic part

6.3.1 Test cases

Each test case contains the test purpose text from EN 300 185-5 [4]. To be able to read and understand the test case dynamic behaviour it is recommended that the test steps are understood first.

6.3.2 Test steps

6.3.2.1 PTC1_IN

This test step describes the behaviour of the PTC1 for support of an incoming call at the MTC (served user side). Thus PTC1 is the originator of the call. The PTC1 receives a CM from the MTC in order to send the SETUP message which begins the call establishment. The test step is terminated by receipt of a RELEASE message or by appropriate CM from the MTC.

6.3.2.2 PTC1_OUT

This test step describes the behaviour of the PTC1 for support of an outgoing call at the MTC (served user side). Thus PTC1 is at the destination side of the call. The test step is terminated by receipt of a RELEASE message or by appropriate CM from the MTC.

The behaviour is regulated from the MTC by means of CMs sent via CPA1 co-ordination point. Thus if the PTC is expected to receive a message it receives a CM beforehand telling it what message to expect. On the other hand if the MTC wishes to receive a message from the IUT it may do this by first sending a CM to PTC1. Depending on the contents of the CM PTC1 may then send a message to the IUT eventually provoking the IUT to send a message at the side of the MTC.

6.3.3 Defaults

Note the use of the RETURN statement which is defined in DAM1 of ISO/IEC 9646-3 [8]. This allows valid background behaviour to be handled in the default tree with a possibility to return to the original set of alternatives in the test case.

7 ATS to TP map

The identifiers used for the TPs are re-used as test case names. Thus there is a straightforward one-to-one mapping.

8 PCTR conformance

A test laboratory, when requested by a client to produce a PCTR, is required, as specified in ISO/IEC 9646-5 [10], to produce a PCTR conformant with the PCTR template given in annex B of ISO/IEC 9646-5 [10].

Furthermore, a test laboratory, offering testing for the ATS specification contained in annex C, when requested by a client to produce a PCTR, is required to produce a PCTR conformant with the PCTR proforma contained in annex A of the present document.

A PCTR which conforms to this PCTR proforma specification shall preserve the content and ordering of the clauses contained in annex A. Clause A.6 of the PCTR may contain additional columns. If included, these shall be placed to the right of the existing columns. Text in italics may be retained by the test laboratory.

9 PIXIT conformance

A test realizer, producing an executable test suite for the ATS specification contained in annex C, is required, as specified in ISO/IEC 9646-4 [9], to produce an augmented partial PIXIT proforma conformant with this partial PIXIT proforma specification.

An augmented partial PIXIT proforma which conforms to this partial PIXIT proforma specification shall, as a minimum, have contents which are technically equivalent to annex B. The augmented partial PIXIT proforma may contain additional questions that need to be answered in order to prepare the Means Of Testing (MOT) for a particular IUT.

A test laboratory, offering testing for the ATS specification contained in annex C, is required, as specified in ISO/IEC 9646-5 [10], to further augment the augmented partial PIXIT proforma to produce a PIXIT proforma conformant with this partial PIXIT proforma specification.

A PIXIT proforma which conforms to this partial PIXIT proforma specification shall, as a minimum, have contents which are technically equivalent to annex B. The PIXIT proforma may contain additional questions that need to be answered in order to prepare the test laboratory for a particular IUT.

10 ATS conformance

The test realizer, producing MOT and ExTS for this ATS specification, shall comply with the requirements of ISO/IEC 9646-4 [9]. In particular, these concern the realization of an ExTS based on each ATS. The test realizer shall provide a statement of conformance of the MOT to this ATS specification.

An ExTS which conforms to this ATS specification shall contain test groups and test cases which are technically equivalent to those contained in the ATS in annex C. All sequences of test events comprising an abstract test case shall be capable of being realized in the executable test case. Any further checking which the test system might be capable of performing is outside the scope of this ATS specification and shall not contribute to the verdict assignment for each test case.

Test laboratories running conformance test services using this ATS shall comply with ISO/IEC 9646-5 [10].

A test laboratory which claims to conform to this ATS specification shall use an MOT which conforms to this ATS.

Annex A (normative): Protocol Conformance Test Report (PCTR) proforma

Notwithstanding the provisions of the copyright clause related to the text of the present document, ETSI grants that users of the present document may freely reproduce the PCTR proforma in this annex so that it can be used for its intended purposes and may further publish the completed PCTR.

A.1 Identification summary

A.1.1 Protocol conformance test report

PCTR number:	
PCTR date:	
Corresponding SCTR number:	
Corresponding SCTR date:	
Test laboratory identification:	
Test laboratory manager:	
Signature:	

A.1.2 IUT identification

Name:	
Version:	
Protocol specification:	EN 300 185-1
PICS:	
Previous PCTRs (if any):	

A.1.3 Testing environment

PIXIT Reference number:	
ATS Specification:	EN 300 185-6
Abstract Test Method:	Multi-party test method (see ISO/IEC 9646-2)
Means of Testing identification:	
Dates of testing:	
Conformance log reference(s):	
Retention date for log reference(s):	

A.1.4 Limits and reservations

Additional information relevant to the technical contents or further use of the test report, or to the rights and obligations of the test laboratory and the client, may be given here. Such information may include restriction on the publication of the report.

.....

.....

.....

.....

A.1.5 Comments

Additional comments may be given by either the client or the test laboratory on any of the contents of the PCTR, for example, to note disagreement between the two parties.

.....

.....

.....

.....

A.2 IUT conformance status

This IUT has / has not been shown by conformance assessment to be non-conforming to the specified protocol specification.

Strike the appropriate words in this sentence. If the PICS for this IUT is consistent with the static conformance requirements (as specified in clause A.3 of this report) and there are no "FAIL" verdicts to be recorded (in clause A.6) strike the word "has", otherwise strike the words "has not".

A.3 Static conformance summary

The PICS for this IUT is / is not consistent with the static conformance requirements in the specified protocol.

Strike the appropriate words in this sentence.

A.4 Dynamic conformance summary

The test campaign did / did not reveal errors in the IUT.

Strike the appropriate words in this sentence. If there are no "FAIL" verdicts to be recorded (in clause A.6 of this report) strike the word "did", otherwise strike the words "did not".

Summary of the results of groups of tests:

.....
.....
.....
.....

A.5 Static conformance review report

If clause A.3 indicates non-conformance, this clause itemizes the mismatches between the PICS and the static conformance requirements of the specified protocol specification.

.....
.....
.....
.....
.....
.....
.....

A.6 Test campaign report

ATS reference	Selected? (Y/N)	Run? (Y/N)	Verdict	Observations
CONF_N01_001				
CONF_N01_002				
CONF_N01_003				
CONF_N01_004				
CONF_N01_005				
CONF_N01_006				
CONF_N02_001				
CONF_N02_002				
CONF_N02_003				
CONF_N02_004				
CONF_N02_005				
CONF_N02_006				
CONF_N02_007				
CONF_N02_008				
CONF_N02_009				
CONF_N02_010				
CONF_N02_011				
CONF_N02_012				
CONF_N02_013				
CONF_N03_001				
CONF_N03_002				
CONF_N03_003				
CONF_N03_004				
CONF_N03_005				
CONF_N03_006				
CONF_N03_007				
CONF_N03_008				
CONF_N03_009				
CONF_N03_010				
CONF_N03_011				
CONF_N03_012				
CONF_N03_013				
CONF_N03_014				

(continued)

Annex B (normative): Partial PIXIT proforma

Notwithstanding the provisions of the copyright clause related to the text of the present document, ETSI grants that users of the present document may freely reproduce the partial PIXIT proforma in this annex so that it can be used for its intended purposes and may further publish the completed PIXIT.

B.1 Identification summary

PIXIT number:

.....

Test laboratory name:

.....

Date of issue:

.....

Issued to:

.....

B.2 Abstract test suite summary

Protocol specification: EN 300 185-1

ATS specification: EN 300 185-6

Abstract test method: Multi-party test method (see ISO/IEC 9646-2)

B.3 Test laboratory

Test laboratory identification:

.....

Accreditation status of the test service:

.....

Accreditation reference:

.....

Test laboratory manager:

.....

Test laboratory contact:

.....

Means of testing:

.....

Test laboratory instructions for completion:

.....

B.4 Client (of the test laboratory)

Client identification:

.....

Client test manager:

.....

Client contact:

.....

Test facilities required:

.....

B.5 System Under Test (SUT)

Name:

.....

Version:

.....

SCS reference:

.....

Machine configuration:

.....

Operating system identification:

.....

IUT identification:

.....

PICS (all layers):

.....

.....

Limitations of the SUT:

.....

Environmental conditions:

.....

B.6 Protocol information

B.6.1 Protocol identification

Specification reference: EN 300 185-1

Protocol version:

PICS reference:

NOTE: The PICS reference should reference a completed PICS which is conformant with the PICS proforma contained in EN 300 185-2.

B.6.2 Parameter values

Table B.1: Parameter values

Item	Question	Supported? (Y/N)	Allowed values	Value
1.1	Does the IUT support Basic Access?		N/A	N/A
1.2	What length of Call Reference value is used?		1, 2	
1.3	What is the maximum conference size supported by the network?		0 to 127	
1.4	Does the IUT allow the release and re-establishment of the layer 2 multiple frame established operation at the start of each test case? (NOTE)		N/A	N/A
NOTE:	This procedure is used to re-initialize all layer 2 counters before starting a test case. The value of this PIXIT item can be set to "No" for accesses where the layer 2 multiple frame established operation release and re-establishment may cause problems.			

B.6.3 Codings of information elements

Table B.2: Codings of information elements

Item	Information element: provide, if possible, ...	Supported? (Y/N)	Value
2.1	a coding of a Bearer Capability information element, which the IUT is NOT compatible with for the purpose of CONF (i.e. non-speech capability)		

B.6.4 Configuration of IUT

Table B.3: Actions required to configure the IUT

Item	Action: What actions, if possible, have to be taken to configure the IUT ...	Supported? (Y/N)	Stimulus (action taken)
3.1	for access subscribed to CONF supplementary service		
3.2	for access NOT subscribed to CONF supplementary service		
3.3	for lack of conference bridge or other resources		
3.4	so that the addition of a new remote user will be in violation of Closed User Group rules		
3.5	so that it transmits a "notActive" return error component in response to Isolate, Reattach or DropCONF invoke components		

B.6.5 Timer values

Table B.4: Timer values

Item	Timer: Give a value for the timer that is used to ...	Value (in seconds)
4.1	wait for the test operator to perform an implicit send action or to wait for a PTC to react (TWAIT)	
4.2	wait for the IUT to respond to a stimulus sent by the tester (TAC)	
4.3	control that the IUT does not respond to a stimulus sent by the tester (TNOAC)	
NOTE: The IUT provider may fill in a value range rather than a fixed value for the test management timers. During test execution the test laboratory will choose specific values for the timers dependant on the means of testing used. These specific values may even be beyond the range given by the IUT provider, if this is necessary for achieving satisfactory test results.		

B.7 Basic call PIXIT items

B.7.1 Parameter values - information element codings

Table B.5: Codings of information elements

Item	Information element: provide, if possible, ...	Supported? (Y/N)	Value
N1.1	a coding of a Bearer Capability information element, which the IUT is compatible with, for the purpose of accepting received SETUP messages and which may be used in SETUP messages to be transmitted		
N1.2	a coding of a High layer compatibility information element, which the IUT is compatible with, for the purpose of accepting received SETUP messages and which may be used in SETUP messages to be transmitted		
N1.3	a coding of a Low layer compatibility information element, which the IUT is compatible with, for the purpose of accepting received SETUP messages and which may be used in SETUP messages to be transmitted		
N1.4	a Called party number information element, which the IUT is compatible with, for ...		
N1.4.1	served user access		
N1.4.2	first remote user access		
N1.4.3	second remote user access		
N1.4.4	third remote user access		
N1.5	preferred channel number to be used for the purpose of accepting received SETUP messages, for ... (note 1)		
N1.5.1	single call at served user side		
N1.5.2	second call at served user side		
N1.5.3	first call at remote user side		
N1.5.4	second call at remote user side		
N1.5.5	third call at remote user side		
NOTE 1: Items N1.5.1 to N1.5.5 are applicable for primary rate access only.			
NOTE 2: As this is a general table used for all supplementary services, all items N1.4.1 to N1.4.4, and N1.5.1 to N1.5.5 (if primary rate access is supported), are not always required, but should be supplied if possible.			

Annex C (normative): Abstract Test Suite (ATS)

This ATS has been produced using the Tree and Tabular Combined Notation (TTCN) according to ISO/IEC 9646-3 [8].

The ATS was developed on a separate TTCN software tool and therefore the TTCN tables are not completely referenced in the table contents. The ATS itself contains a test suite overview part which provides additional information and references (see also annex D).

C.1 The TTCN Graphical form (TTCN.GR)

The TTCN.GR representation of this ATS is contained in an Adobe Portable Document Format™ file (CONF_N15.PDF contained in archive 1ppi0j1c.ZIP) which accompanies the present document.

C.2 The TTCN Machine Processable form (TTCN.MP)

The TTCN.MP representation corresponding to this ATS is contained in an ASCII file (CONF_N15.MP contained in archive 1ppi0j1c.ZIP) which accompanies the present document.

NOTE: According to ISO/IEC 9646-3 [8], in case of a conflict in interpretation of the operational semantics of TTCN.GR and TTCN.MP, the operational semantics of the TTCN.GR representation takes precedence.

Annex D (informative): General structure of ATS

This annex gives a simple listing of the order of types of tables which appear in a typical supplementary service ATS. This is intended as an aid in helping readers find particular sections quickly.

Test Suite Overview

Test Suite Structure

Test Case Index

Test Step Index

Default Index

Declarations Part

Simple Type Definitions

Structured Type Definitions

ASN.1 Type Definitions

Test Suite Operation Definitions

Test Suite Parameter Declarations

Test Case Selection Expression Definitions

Test Suite Constant Declarations

Test Case Variable Declarations

PCO Declarations

Co-ordination Point Declarations

Timer Declarations

Test Component Declarations

Test Components Configuration Declarations

TTCN ASP Type Definition

TTCN PDU Type Definition

TTCN CM Type Definition

Alias Definitions

Constraints Part

Structured Type Constraint Declarations

ASN.1 Type Constraint Declarations

TTCN ASP Constraint Declarations

TTCN PDU Constraint Declarations

TTCN CM Constraint Declarations

Dynamic Part

Test Case Dynamic Behaviour

Test Step Dynamic Behaviour

Default Dynamic Behaviour

Annex E (informative): Changes with respect to the previous ETS 300 185-6

The following changes have been done:

- conversion to EN layout;
- replacement of references to ETS 300 102 with EN 300 403-1 [1];
- substitution of non-specific references to basic standards where the intention is to refer to the latest version.

History

Document history		
Edition 1	October 1996	Publication as ETS 300 185-6
V1.3.2	December 1998	Public Enquiry PE 9917: 1998-12-25 to 1999-04-23