

ETSI EN 300 175-8 V2.2.1 (2009-02)

European Standard (Telecommunications series)

Digital Enhanced Cordless Telecommunications (DECT); Common Interface (CI); Part 8: Speech and audio coding and transmission



Reference

REN/DECT-000248-8

Keywords

7 kHz, audio, broadband, codec, DECT,
handsfree, IMT-2000, loudspeaking, mobility,
narrowband, quality, radio, speech, TDD, TDMA,
telephony, terminal

ETSI

650 Route des Lucioles
F-06921 Sophia Antipolis Cedex - FRANCE

Tel.: +33 4 92 94 42 00 Fax: +33 4 93 65 47 16

Siret N° 348 623 562 00017 - NAF 742 C
Association à but non lucratif enregistrée à la
Sous-Préfecture de Grasse (06) N° 7803/88

Important notice

Individual copies of the present document can be downloaded from:

<http://www.etsi.org>

The present document may be made available in more than one electronic version or in print. In any case of existing or perceived difference in contents between such versions, the reference version is the Portable Document Format (PDF). In case of dispute, the reference shall be the printing on ETSI printers of the PDF version kept on a specific network drive within ETSI Secretariat.

Users of the present document should be aware that the document may be subject to revision or change of status. Information on the current status of this and other ETSI documents is available at

<http://portal.etsi.org/tb/status/status.asp>

If you find errors in the present document, please send your comment to one of the following services:

http://portal.etsi.org/chaicor/ETSI_support.asp

Copyright Notification

No part may be reproduced except as authorized by written permission.
The copyright and the foregoing restriction extend to reproduction in all media.

© European Telecommunications Standards Institute 2009.
All rights reserved.

DECT™, **PLUGTESTS™**, **UMTS™**, **TIPHON™**, the TIPHON logo and the ETSI logo are Trade Marks of ETSI registered for the benefit of its Members.

3GPP™ is a Trade Mark of ETSI registered for the benefit of its Members and of the 3GPP Organizational Partners.

LTE™ is a Trade Mark of ETSI currently being registered

for the benefit of its Members and of the 3GPP Organizational Partners.

GSM® and the GSM logo are Trade Marks registered and owned by the GSM Association.

Contents

Intellectual Property Rights	11
Foreword.....	11
1 Scope	12
2 References	12
2.1 Normative references	13
2.2 Informative references.....	14
3 Definitions, symbols and abbreviations	15
3.1 Definitions.....	15
3.2 Symbols and abbreviations.....	17
4 Configurations.....	18
4.1 Reference configuration	18
4.1.1 Basic configuration	18
4.1.2 Portable Part (PP)	19
4.1.2.1 Functional organization.....	19
4.1.2.2 Volume control	20
4.1.3 Fixed Part (FP).....	20
4.1.3.1 Digital interface.....	20
4.1.3.2 Analog interface	22
4.1.3.3 FP adaptive volume control	22
4.2 Test configurations	22
5 Encoding.....	22
5.1 32 kbit/s full term (ADPCM) G.726.....	22
5.1.1 Algorithm.....	22
5.1.2 Bit sequence.....	23
5.1.3 Characteristics of G.726 ADPCM codec	23
5.2 64 kbit/s PCM G.711.....	23
5.2.1 Algorithm.....	23
5.2.2 Bit sequence.....	23
5.2.3 Characteristics of G.711 PCM codec.....	24
5.2.4 Automatic detection of FAX/modem tone and switch to G.711	24
5.3 Wideband speech codec G.722 at 64 kbit/s.....	24
5.3.1 Algorithm.....	24
5.3.2 Bit sequence.....	24
5.3.3 Characteristics of G.722 wideband codec.....	24
5.3.4 Optional Packet Loss Concealment algorithm (PLC).....	25
5.4 Wideband speech codec G.729.1 up to 32 kbit/s.....	25
5.4.1 Algorithm.....	25
5.4.2 Bit sequence.....	25
5.4.3 Characteristics of G.729.1 codec	25
5.4.4 Packet Loss Concealment algorithm (PLC).....	26
5.4.5 Supported bit rate in DECT	26
5.5 Super-wideband MPEG-4 speech and audio coding	26
5.5.1 Algorithm.....	26
5.5.2 64 kbit/s, MPEG-4 ER AAC-LD codec.....	27
5.5.3 32 kbit/s, MPEG-4 ER AAC-LD codec.....	27
5.6 Other codings	27
6 Transmission aspects.....	28
6.1 Relative level.....	28
6.2 Acoustic reference level	28
6.3 Volume control.....	28
7 Audio specifications	28
7.1 Overall description	28
7.1.1 Introduction to DECT audio specifications	28
7.1.2 Introduction to the audio types	28

7.1.3	List of Audio types	29
7.1.4	Audio types for Portable Parts	30
7.1.5	Audio types for Fixed Parts	31
7.1.6	Complete DECT system	31
7.1.7	Structure of the specification of the audio types	31
7.1.8	Audio Types and codecs	37
7.1.9	Audio Types and physical interfaces	37
7.2	Audio types applicable to Portable Parts	37
7.2.1	Performance levels of DECT Portable Parts (handsets).....	37
7.2.2	Type 0: Reference PP (RePP).....	38
7.2.3	PP Type 1a: "Classic" GAP narrowband handset	38
7.2.3.1	Introduction.....	38
7.2.3.2	Compatible services and codecs.....	39
7.2.3.3	Specification.....	39
7.2.4	PP Type 1b: "Improved" GAP narrowband handset.....	39
7.2.4.1	Introduction.....	39
7.2.4.2	Compatible services and codecs.....	39
7.2.4.3	Specification.....	39
7.2.5	PP Type 1c: HATS-tested "standard" narrowband handset	39
7.2.5.1	Introduction.....	39
7.2.5.2	Compatible services and codecs.....	40
7.2.5.3	Specification.....	40
7.2.6	PP Type 1d: HATS-tested "improved" narrowband handset.....	40
7.2.6.1	Introduction.....	40
7.2.6.2	Compatible services and codecs.....	40
7.2.6.3	Specification.....	40
7.2.7	PP Type 3a: HATS tested narrowband "standard" loudspeaking handsfree	40
7.2.7.1	Introduction.....	40
7.2.7.2	Compatible services and codecs.....	41
7.2.7.3	Specification.....	41
7.2.8	PP Type 3b: HATS tested narrowband "improved" loudspeaking handsfree.....	41
7.2.8.1	Introduction.....	41
7.2.8.2	Compatible services and codecs.....	41
7.2.8.3	Specification.....	41
7.2.9	PP Type 2a: P.311-tested wideband handset.....	41
7.2.9.1	Introduction.....	41
7.2.9.2	Compatible services and codecs.....	41
7.2.9.3	Specification.....	42
7.2.10	PP Type 2b: HATS-tested "standard" wideband handset or headset	42
7.2.10.1	Introduction.....	42
7.2.10.2	Compatible services and codecs.....	42
7.2.10.3	Specification.....	42
7.2.11	PP Type 2c: HATS tested "improved" wideband handset or headset	42
7.2.11.1	Introduction.....	42
7.2.11.2	Compatible services and codecs.....	42
7.2.11.3	Specification.....	43
7.2.12	PP Type 4a: HATS tested wideband "standard" loudspeaking handsfree	43
7.2.12.1	Introduction.....	43
7.2.12.2	Compatible services and codecs.....	43
7.2.12.3	Specification.....	43
7.2.13	PP Type 4b: HATS tested wideband "improved" loudspeaking and handsfree.....	43
7.2.13.1	Introduction.....	43
7.2.13.2	Compatible services and codecs.....	44
7.2.13.3	Specification.....	44
7.2.14	PP Type 5a: super-wideband 14 kHz handset.....	44
7.2.14.1	Introduction.....	44
7.2.14.2	Compatible services and codecs.....	44
7.2.14.3	Specification.....	44
7.2.15	PP Type 5b: super-wideband 14 kHz loudspeaking handsfree	44
7.2.15.1	Introduction.....	44
7.2.15.2	Compatible services and codecs.....	44
7.2.15.3	Specification.....	44

7.2.16	PP Type 6: PPs with external 2 wire, 3,1 kHz telephony interface.....	44
7.2.16.1	Introduction.....	44
7.2.16.2	Compatible services and codecs.....	44
7.2.16.3	Specification.....	45
7.3	Audio transmission types applicable to Fixed Parts.....	45
7.3.1	FP Type 0: Reference FP (ReFP).....	45
7.3.2	FP Type 1a: "classical" Fixed Part for ISDN Network.....	46
7.3.2.1	Introduction.....	46
7.3.2.2	Compatible services and codecs.....	46
7.3.2.3	Specifications.....	46
7.3.2.3.1	Transcoding and equalization.....	46
7.3.2.3.2	PP type detection.....	47
7.3.2.3.3	Activation of audio processing functions.....	47
7.3.2.3.4	Transmission specification.....	47
7.3.3	FP Type 1b: "new" Fixed Part for ISDN Network.....	47
7.3.3.1	Introduction.....	47
7.3.3.2	Compatible services and codecs.....	47
7.3.3.3	Specification.....	48
7.3.3.3.1	Transcoding and equalization.....	48
7.3.3.3.2	PP type detection.....	48
7.3.3.3.3	Activation of audio processing functions.....	48
7.3.3.3.4	Transmission specification.....	49
7.3.4	FP Type 2: FP with analog 2-wire interface, 3,1 kHz service.....	49
7.3.4.1	Introduction.....	49
7.3.4.2	Compatible services, physical interfaces and codecs.....	49
7.3.4.3	Specification.....	49
7.3.4.3.1	Transcoding, equalization and conversion.....	49
7.3.4.3.2	PP type detection and activation of audio processing functions.....	49
7.3.4.3.3	Transmission specification.....	50
7.3.5	FP Type 3: VoIP narrowband Fixed Part.....	50
7.3.5.1	Introduction.....	50
7.3.5.2	Compatible services, physical interfaces and codecs.....	50
7.3.5.3	Specification.....	51
7.3.5.3.1	Transcoding and equalization.....	51
7.3.5.3.2	PP type detection.....	51
7.3.5.3.3	Activation of audio processing functions.....	51
7.3.5.3.4	Transmission specification.....	52
7.3.6	FP Type 4: ISDN wideband Fixed Part.....	52
7.3.6.1	Introduction.....	52
7.3.6.2	Compatible services and codecs.....	52
7.3.6.3	Specification.....	52
7.3.6.3.1	Transcoding and equalization.....	52
7.3.6.3.2	PP type detection.....	52
7.3.6.3.3	Activation of audio processing functions.....	53
7.3.6.3.4	Transmission specification.....	53
7.3.7	FP Type 5: VoIP wideband Fixed Part.....	53
7.3.7.1	Introduction.....	53
7.3.7.2	Compatible services, physical interfaces and codecs.....	53
7.3.7.3	Specification.....	54
7.3.7.3.1	Transcoding and equalization.....	54
7.3.7.3.2	PP type detection.....	54
7.3.7.3.3	Activation of audio processing functions.....	54
7.3.7.3.4	Transmission specification.....	55
7.3.8	FP Type 6a: FP handling an Internal call inside a DECT FP (any service).....	55
7.3.8.1	Introduction.....	55
7.3.8.2	Compatible services, physical interfaces and codecs.....	55
7.3.8.3	Specification.....	55
7.3.9	FP Type 6b: FP handling an n-party conference inside a DECT FP (any service).....	55
7.3.9.1	Introduction.....	55
7.3.9.2	Compatible services, physical interfaces and codecs.....	56
7.3.9.3	Specification for the conference bridge.....	56
7.3.10	FP Type 7: DECT Repeater part (REP).....	56

7.3.10.1	Introduction.....	56
7.3.10.2	Compatible services, physical interfaces and codecs.....	56
7.3.10.3	Specification.....	56
7.4	Additional features.....	56
7.4.1	Introduction.....	56
7.4.2	Echo canceller in Fixed Part.....	57
7.4.3	Echo suppressor in Fixed Part.....	57
7.5	Transmission characteristics for Portable Parts.....	58
7.5.1	Transmission characteristics for Portable Part type 1a ("Classic GAP" handset).....	58
7.5.1.1	PP frequency responses.....	58
7.5.1.1.1	Sending.....	58
7.5.1.1.2	Receiving.....	59
7.5.1.2	PP sending and receiving loudness ratings.....	59
7.5.1.2.1	Nominal values.....	59
7.5.1.2.2	User-controlled volume control in PP.....	59
7.5.1.2.3	PP adaptive volume control.....	60
7.5.1.3	Sidetone.....	60
7.5.1.3.1	Talker sidetone.....	60
7.5.1.3.2	Listener sidetone.....	60
7.5.1.4	Terminal coupling loss.....	61
7.5.1.4.1	Weighted Terminal Coupling Loss (TCLw).....	61
7.5.1.4.2	Stability loss.....	61
7.5.1.5	Distortion.....	61
7.5.1.5.1	Sending.....	61
7.5.1.5.2	Receiving.....	61
7.5.1.5.3	Sidetone.....	62
7.5.1.6	Out of band signals.....	62
7.5.1.6.1	Sending (discrimination against out of band input signals).....	62
7.5.1.6.2	Receiving (spurious out of band signals).....	62
7.5.1.7	Noise.....	62
7.5.1.7.1	Sending.....	62
7.5.1.7.2	Band-limited noise.....	62
7.5.1.7.3	Receiving.....	62
7.5.1.7.4	Level of sampling frequency (receiving).....	62
7.5.1.8	Acoustic shock.....	63
7.5.1.8.1	Continuous signal.....	63
7.5.1.8.2	Peak signal.....	63
7.5.1.9	PP Delay.....	63
7.5.1.10	PP ambient noise rejection.....	63
7.5.2	Additional requirements for PP type 1b ("improved GAP" handset).....	63
7.5.2.1	Terminal coupling loss.....	63
7.5.2.1.1	Weighted Terminal Coupling Loss (TCLw).....	63
7.5.2.2	Attenuation Range in Sending Direction during Double Talk $A_{H,S,dt}$	63
7.5.2.3	Attenuation Range in Receiving Direction during Double Talk $A_{H,R,dt}$	64
7.5.2.4	Activation in Sending Direction.....	64
7.5.2.5	Activation in Receiving Direction.....	65
7.5.3	Transmission characteristics for PP types 1c and 1d (HATS tested, narrowband telephony handsets).....	65
7.5.3.1	PP frequency responses.....	65
7.5.3.1.1	Sending.....	65
7.5.3.1.2	Receiving.....	66
7.5.3.2	PP sending and receiving loudness ratings.....	68
7.5.3.2.1	Nominal values.....	68
7.5.3.2.2	User-controlled volume control in PP.....	69
7.5.3.2.3	PP adaptive volume control.....	69
7.5.3.3	Sidetone.....	70
7.5.3.3.1	Talker sidetone.....	70
7.5.3.3.2	D Factor.....	70
7.5.3.3.3	Sidetone delay.....	70
7.5.3.4	Terminal coupling loss.....	70
7.5.3.4.1	TCLw of Portable Part.....	70
7.5.3.4.2	Stability loss.....	71
7.5.3.5	Distortion.....	71

7.5.3.5.1	Sending Distortion.....	71
7.5.3.5.2	Receiving Distortion.....	71
7.5.3.6	Out of band signals.....	72
7.5.3.6.1	Out-of-Band Signals in Send direction.....	72
7.5.3.6.2	Out-of-band signals in receiving direction	72
7.5.3.7	Noise	72
7.5.3.7.1	Sending.....	72
7.5.3.7.2	Receiving.....	72
7.5.3.8	Acoustic shock	73
7.5.3.8.1	Continuous signal	73
7.5.3.8.2	Peak signal.....	73
7.5.3.9	Delay.....	73
7.5.3.10	Variation of gain with input level-sending	73
7.5.3.11	Double Talk Performance	74
7.5.3.11.1	Attenuation Range in Sending Direction during Double Talk $A_{H,S,dt}$	74
7.5.3.11.2	Attenuation Range in Receiving Direction during Double Talk $A_{H,S,dt}$	74
7.5.3.11.3	Detection of Echo Components during Double Talk.....	75
7.5.3.11.4	Minimum activation level and sensitivity of double talk detection	75
7.5.3.12	Switching characteristics.....	75
7.5.3.12.1	Activation in Sending Direction	75
7.5.3.12.2	Activation in Receiving Direction	76
7.5.3.12.3	Silence Suppression and Comfort Noise Generation.....	76
7.5.3.12.4	Performance in sending direction in the presence of background noise	76
7.5.3.12.5	Speech Quality in the Presence of Background Noise.....	76
7.5.3.12.6	Quality of Background Noise Transmission (with Far End Speech).....	77
7.5.3.12.7	Quality of background noise transmission (with Near End Speech)	77
7.5.3.13	Quality of echo cancellation.....	77
7.5.3.13.1	Temporal echo effects	77
7.5.3.13.2	Spectral Echo Attenuation.....	77
7.5.4	Transmission characteristics for PP types 3a and 3b (narrowband loudspeaking and handsfree devices).....	78
7.5.4.1	Sending sensitivity/frequency response	78
7.5.4.2	Receive sensitivity/frequency response.....	78
7.5.4.3	Sending loudness rating	81
7.5.4.4	Receive loudness rating.....	81
7.5.4.5	Sending distortion	82
7.5.4.6	Receiving distortion	82
7.5.4.7	Out-of-band signals in sending direction	83
7.5.4.8	Out-of-band signals in receiving direction.....	83
7.5.4.9	Sending noise	83
7.5.4.10	Receiving noise	83
7.5.4.11	Terminal Coupling Loss of PP.....	84
7.5.4.12	Stability Loss of PP.....	84
7.5.4.13	Double Talk Performance	84
7.5.4.13.1	Attenuation Range in Sending Direction during Double Talk $A_{H,S,dt}$	84
7.5.4.13.2	Attenuation Range in Receiving Direction during Double Talk $A_{H,R,dt}$	85
7.5.4.13.3	Detection of Echo Components during Double Talk.....	85
7.5.4.13.4	Minimum activation level and sensitivity of double talk detection	86
7.5.4.14	Switching characteristics.....	86
7.5.4.14.1	Activation in Sending Direction	86
7.5.4.14.2	Activation in Receiving Direction	86
7.5.4.14.3	Silence Suppression and Comfort Noise Generation.....	86
7.5.4.14.4	Performance in sending direction in the presence of background noise	87
7.5.4.14.5	Speech Quality in the Presence of Background Noise.....	87
7.5.4.14.6	Quality of Background Noise Transmission (with Far End Speech).....	87
7.5.4.14.7	Quality of background noise transmission (with Near End Speech)	87
7.5.4.15	Quality of echo cancellation.....	87
7.5.4.15.1	Temporal echo effects	88
7.5.4.15.2	Spectral Echo Attenuation.....	88
7.5.5	Transmission characteristics for PP type 2a (P.311 tested, wideband handset).....	88
7.5.5.1	Sending characteristics.....	88
7.5.5.1.1	Loudness rating	88

7.5.5.1.2	Sensitivity/frequency characteristics	88
7.5.5.1.3	Noise.....	89
7.5.5.1.4	Distortion.....	89
7.5.5.1.5	Discrimination against out-of-band input signals	89
7.5.5.2	Receiving characteristics.....	89
7.5.5.2.1	Loudness rating	89
7.5.5.2.2	Sensitivity/frequency characteristics	89
7.5.5.2.3	Noise.....	89
7.5.5.2.4	Distortion.....	90
7.5.5.2.5	Spurious out-of-band receiving signals	90
7.5.5.3	Sidetone characteristics.....	90
7.5.5.3.1	Talker sidetone	90
7.5.5.3.2	Sidetone distortion.....	90
7.5.5.4	Echo path loss characteristics.....	90
7.5.5.4.1	Weighted terminal coupling loss	90
7.5.5.4.2	Stability loss	91
7.5.6	Transmission characteristics for PP type 2b and 2c (HATS tested wideband handsets)	91
7.5.6.1	PP frequency responses.....	91
7.5.6.1.1	Sending.....	91
7.5.6.1.2	Receiving.....	92
7.5.6.2	PP send and receive loudness ratings	94
7.5.6.2.1	Nominal values.....	94
7.5.6.2.2	User-controlled volume control in PP	95
7.5.6.2.3	PP adaptive volume control.....	95
7.5.6.3	Sidetone.....	95
7.5.6.3.1	Talker sidetone	95
7.5.6.3.2	D Factor	96
7.5.6.3.3	Sidetone delay	96
7.5.6.4	Terminal coupling loss.....	96
7.5.6.4.1	Weighted Terminal Coupling Loss (TCLw).....	96
7.5.6.4.2	Stability loss	96
7.5.6.5	Distortion	97
7.5.6.5.1	Sending Distortion.....	97
7.5.6.5.2	Receiving Distortion.....	97
7.5.6.6	Noise	97
7.5.6.6.1	Sending.....	97
7.5.6.6.2	Receiving.....	98
7.5.6.7	Acoustic shock.....	98
7.5.6.7.1	Continuous signal	98
7.5.6.7.2	Peak signal.....	98
7.5.6.8	Delay	98
7.5.6.9	Variation of gain with input level-sending.....	98
7.5.6.10	Double talk Performance.....	99
7.5.6.10.1	Attenuation Range in Sending Direction during Double Talk $A_{H,S,dt}$	99
7.5.6.10.2	Attenuation Range in Receiving Direction during Double Talk $A_{H,R,dt}$	100
7.5.6.10.3	Detection of Echo Components during Double Talk.....	100
7.5.6.10.4	Minimum activation level and sensitivity of double talk detection.....	100
7.5.6.11	Switching characteristics.....	100
7.5.6.11.1	Activation in Sending Direction	101
7.5.6.11.2	Activation in Receiving Direction	101
7.5.6.11.3	Silence Suppression and Comfort Noise Generation.....	101
7.5.6.11.4	Performance in Sending in the Presence of Background Noise.....	101
7.5.6.11.5	Speech Quality in the Presence of Background Noise.....	102
7.5.6.11.6	Quality of Background Noise Transmission (with Far End Speech).....	102
7.5.6.11.7	Quality of background noise transmission (with Near End Speech)	102
7.5.6.12	Quality of echo cancellation.....	102
7.5.6.12.1	Temporal echo effects	102
7.5.6.12.2	Spectral Echo Attenuation.....	103
7.5.7	Transmission characteristics for PP types 4a and 4b (HATS Tested wideband loudspeaking and handsfree devices).....	103
7.5.7.1	Sending sensitivity/frequency response	103
7.5.7.2	Receive sensitivity/frequency response.....	104

7.5.7.3	Sending loudness rating	107
7.5.7.4	Receive loudness rating.....	107
7.5.7.5	Sending distortion	108
7.5.7.6	Receiving distortion	108
7.5.7.7	Out-of-band signals in sending direction	109
7.5.7.8	Out-of-band signals in receiving direction	109
7.5.7.9	Sending noise	109
7.5.7.10	Receiving noise	109
7.5.7.11	Terminal Coupling Loss.....	110
7.5.7.12	Stability Loss.....	110
7.5.7.13	Double Talk Performance	110
7.5.7.13.1	Attenuation Range in Sending Direction during Double Talk $A_{H,S,dt}$	111
7.5.7.13.2	Attenuation Range in Receiving Direction during Double Talk $A_{H,R,dt}$	111
7.5.7.13.3	Detection of Echo Components during Double Talk.....	111
7.5.7.13.4	Minimum activation level and sensitivity of double talk detection	112
7.5.7.14	Switching characteristics.....	112
7.5.7.14.1	Activation in Sending Direction	112
7.5.7.14.2	Activation in Receiving Direction	112
7.5.7.14.3	Silence Suppression and Comfort Noise Generation.....	113
7.5.7.14.4	Performance in sending direction in the presence of background noise	113
7.5.7.14.5	Speech Quality in the Presence of Background Noise.....	113
7.5.7.14.6	Quality of Background Noise Transmission (with Far End Speech).....	113
7.5.7.14.7	Quality of background noise transmission (with Near End Speech)	113
7.5.7.15	Quality of echo cancellation.....	114
7.5.7.15.1	Temporal echo effects	114
7.5.7.15.2	Spectral Echo Attenuation.....	114
7.6	Transmission characteristics for Fixed Parts	114
7.6.1	Transmission characteristics for FP type 1a ("Classic" Fixed Part with ISDN Network interface, 3,1 kHz service)	114
7.6.1.1	Reduction of echo from PP	114
7.6.1.2	FP Network echo control	115
7.6.1.3	FP adaptive volume control	116
7.6.1.4	FP Delay.....	116
7.6.2	Transmission characteristics for FP type 1b ("new" Fixed Part with ISDN Network interface, 3,1 kHz service)	116
7.6.2.1	FP Network echo control	116
7.6.2.2	FP adaptive volume control	116
7.6.2.3	FP Delay.....	117
7.6.3	Transmission characteristics for FP type 2 (Fixed Part with analog 2-wire interface, 3,1 kHz service)... 117	
7.6.3.1	FP adaptive volume control	117
7.6.3.2	Network echo control	117
7.6.3.3	Additional requirements for DECT FP provided with a 2-wire PSTN interface.....	118
7.6.3.3.1	General	118
7.6.3.3.2	Speech performance characteristics.....	118
7.6.3.4	FP Delay.....	119
7.6.4	Transmission characteristics for FP type 3 (Fixed Part with VoIP interface, 3,1 kHz service)..... 119	
7.6.4.1	Send delay	119
7.6.4.2	Receive delay	119
7.6.4.3	Adaptive volume control.....	120
7.6.5	Transmission characteristics for FP type 4 (Fixed Part with ISDN network interface, wideband service).....	120
7.6.5.1	FP adaptive volume control	120
7.6.5.2	FP Delay.....	120
7.6.6	Transmission characteristics for FP type 5 (Fixed Part with VoIP interface, wideband service)	120
7.6.6.1	Send Delay	120
7.6.6.2	Receive delay	121
7.6.6.3	FP adaptive volume control	121
8	Additional features	121
8.1	Loudspeaking hands-free and headset facilities	121
8.1.1	Loudspeaking hands-free facility.....	121
8.1.2	Headset facility	121

8.2	Tandem with mobile radio network.....	121
8.2.1	Tandem with GSM	122
8.2.1.1	Network echo control.....	122
8.2.1.2	Terminal coupling loss.....	122
8.2.1.3	The GSM mobile transmitter operates in continuous mode.....	122
8.2.1.4	The GSM mobile transmitter operates in discontinuous mode, DTX.....	122
8.3	DECT connected to the GSM fixed network.....	122
8.3.1	Network echo control.....	123
8.3.2	Terminal coupling loss.....	123
8.4	Wireless Relay Stations (WRS).....	123
8.4.1	Modified FP network echo control requirements for implementation of 2 and 3 CRFP links in cascade.....	124
Annex A (informative): Description of "reference" echo control devices.....		125
A.1	Handset echo	125
A.1.1	Overview	125
A.1.1.1	Connection to the PSTN/ISDN.....	125
A.1.1.1.1	Local and national calls.....	125
A.1.1.1.2	Long distance connections with echo control devices in the PSTN/ISDN, e.g. calls via satellites.....	125
A.1.1.2	Connection to the GSM network	126
A.1.2	Implementation of the FP echo control function	126
A.1.2.1	Suppression threshold.....	127
A.1.2.2	Static characteristics of activation control	127
A.1.2.3	Dynamic characteristics of activation control.....	127
A.2	Network echo	127
A.2.1	Soft suppressor implementation of requirement 2.....	128
A.2.1.1	Static characteristics	129
A.2.1.2	Dynamic characteristics	129
A.2.2	Additional echo control for a 2-wire interface of requirement 1	129
A.2.3	Echo canceller used for both requirements 1 and 2.....	130
Annex B (informative): Local loop application		131
B.1	DECT tethered local loop replacement with 2-wire PP end system.....	131
B.1.1	TCLw requirements.....	131
B.1.2	Network echo	132
Annex C (informative): GSM Discontinuous Transmission (DTX), and Voice Activity Detection (VAD).....		133
Annex D (informative): Speech levels in relation to ambient room noise and examples of adaptive volume control settings		134
Annex E (informative): Echo related topics.....		135
E.1	Summary table on echo parameters for PPs and FPs	135
E.2	General information about Delay-Echo interaction for DECT terminals.....	139
Annex F (informative): Guidelines on specific requirements.....		142
F.1	Delay requirements for FPs with VoIP interface	142
F.1.1	Delay requirements for FP type 3 (Fixed Part with VoIP interface, 3,1 kHz service).....	142
F.1.1.1	Send delay.....	142
F.1.1.2	Receive delay.....	143
F.1.2	Delay requirements for FP type 5 (Fixed Part with VoIP interface, wideband service).....	144
F.1.2.1	Send Delay.....	144
F.1.2.2	Receive delay.....	145
Annex G (informative): Bibliography.....		147
Annex H (informative): Change history		148
History		149

Intellectual Property Rights

IPRs essential or potentially essential to the present document may have been declared to ETSI. The information pertaining to these essential IPRs, if any, is publicly available for **ETSI members and non-members**, and can be found in ETSI SR 000 314: "*Intellectual Property Rights (IPRs); Essential, or potentially Essential, IPRs notified to ETSI in respect of ETSI standards*", which is available from the ETSI Secretariat. Latest updates are available on the ETSI Web server (<http://webapp.etsi.org/IPR/home.asp>).

Pursuant to the ETSI IPR Policy, no investigation, including IPR searches, has been carried out by ETSI. No guarantee can be given as to the existence of other IPRs not referenced in ETSI SR 000 314 (or the updates on the ETSI Web server) which are, or may be, or may become, essential to the present document.

Foreword

This European Standard (Telecommunications series) has been produced by ETSI Project Digital Enhanced Cordless Telecommunications (DECT).

The present document is part 8 of a multi-part deliverable. Full details of the entire series can be found in part 1 [1].

Further details of the DECT system may be found in TR 101 178 [i.6] and ETR 043 [i.7].

National transposition dates	
Date of adoption of this EN:	21 January 2009
Date of latest announcement of this EN (doa):	30 April 2009
Date of latest publication of new National Standard or endorsement of this EN (dop/e):	31 October 2009
Date of withdrawal of any conflicting National Standard (dow):	31 October 2009

1 Scope

The present document is one of the parts of the specification of the Digital Enhanced Cordless Telecommunications (DECT) Common Interface (CI) [1] to [7].

This part of the DECT CI specifies the speech and audio coding and transmission requirements.

In order to ensure satisfactory interworking of different portable and fixed units, it is necessary to specify the transmission performance of the analog information over the digital link. This requires not only use of a common speech algorithm, but also standardization of frequency responses, reference speech levels (or loudness) at the air interface and various other parameters.

The present document applies to DECT equipment which includes all the necessary functions to provide real-time two-way speech conversation. Several speech services are defined in the present document, including conventional 3,1 kHz telephony, wideband 7 kHz voice transmission and super-wideband 14 kHz service. DECT Fixed part providing such services may be connected to the public circuit switched (PSTN/ISDN) network, to private networks or to the Internet.

Tethered fixed point local loop applications are not required to comply with the requirements of the present document.

For the DECT systems which connect to the Public Switched Telephone Network (PSTN) via an analog interface, the additional requirements, which are implemented in the FP, have as much as possible been aligned with TBR 038 [29].

A summary of the control and the use of the DECT echo control functions, to guide on need for options to manufacturers and installers, is found in annex A.

Information concerning test methods can be found in EN 300 176-1 [9] and EN 300 176-2 [10]. The test methods take into account that DECT is a digital system.

The present document includes New Generation DECT, a further development of the DECT standard introducing wideband speech, improved data services, new slot types and other technical enhancements.

2 References

References are either specific (identified by date of publication and/or edition number or version number) or non-specific.

- For a specific reference, subsequent revisions do not apply.
- Non-specific reference may be made only to a complete document or a part thereof and only in the following cases:
 - if it is accepted that it will be possible to use all future changes of the referenced document for the purposes of the referring document;
 - for informative references.

Referenced documents which are not found to be publicly available in the expected location might be found at <http://docbox.etsi.org/Reference>.

NOTE: While any hyperlinks included in this clause were valid at the time of publication ETSI cannot guarantee their long term validity.

2.1 Normative references

The following referenced documents are indispensable for the application of the present document. For dated references, only the edition cited applies. For non-specific references, the latest edition of the referenced document (including any amendments) applies.

- [1] ETSI EN 300 175-1: "Digital Enhanced Cordless Telecommunications (DECT); Common Interface (CI); Part 1: Overview".
- [2] ETSI EN 300 175-2: "Digital Enhanced Cordless Telecommunications (DECT); Common Interface (CI); Part 2: Physical Layer (PHL)".
- [3] ETSI EN 300 175-3: "Digital Enhanced Cordless Telecommunications (DECT); Common Interface (CI); Part 3: Medium Access Control (MAC) layer".
- [4] ETSI EN 300 175-4: "Digital Enhanced Cordless Telecommunications (DECT); Common Interface (CI); Part 4: Data Link Control (DLC) layer".
- [5] ETSI EN 300 175-5: "Digital Enhanced Cordless Telecommunications (DECT); Common Interface (CI); Part 5: Network (NWK) layer".
- [6] ETSI EN 300 175-6: "Digital Enhanced Cordless Telecommunications (DECT); Common Interface (CI); Part 6: Identities and addressing".
- [7] ETSI EN 300 175-7: "Digital Enhanced Cordless Telecommunications (DECT); Common Interface (CI); Part 7: Security features".
- [8] Void.
- [9] ETSI EN 300 176-1: "Digital Enhanced Cordless Telecommunications (DECT); Test specification; Part 1: Radio".
- [10] ETSI EN 300 176-2: "Digital Enhanced Cordless Telecommunications (DECT); Test specification; Part 2: Speech".
- [11] ITU-T Recommendation G.701: "Vocabulary of digital transmission and multiplexing, and pulse code modulation (PCM) terms".
- [12] ITU-T Recommendation G.726: "40, 32, 24, 16 kbit/s Adaptive Differential Pulse Code Modulation (ADPCM)".
- [13] ITU-T Recommendation G.711 (1988): "Pulse Code Modulation (PCM) of voice frequencies".
- [14] ITU-T Recommendation G.722 (1988): "7 kHz audio-coding within 64 kbit/s".
- [15] ITU-T Recommendation G.722 Appendix III: "A high quality packet loss concealment algorithm for G.722".
- [16] ITU-T Recommendation G.722 Appendix IV: "A low-complexity algorithm for packet loss concealment with G.722".
- [17] ITU-T Recommendation G.729.1 (2006): "G.729 based Embedded Variable bit-rate coder: An 8-32 kbit/s scalable wideband coder bitstream interoperable with G.729".
- [18] ISO/IEC JTC1/SC29/WG11 (MPEG): International Standard ISO/IEC 14496-3: 2005/AMD 1:2007: "Information Technology - Coding of audio-visual objects - Part 3: Audio; AMENDMENT 1: Low Delay AAC profile".
- [19] ISO/IEC JTC1/SC29/WG11 (MPEG): International Standard ISO/IEC 14496-3:2005: "Information Technology - Coding of audio-visual objects - Part 3: Audio".
- [20] ITU-T Recommendation P.311 (2005): "Transmission characteristics for wideband (150-7000 Hz) digital handset telephones".
- [21] ITU-T Recommendation P.10: "Vocabulary for performance and quality of service".

- [22] ITU-T Recommendation P.340: "Transmission characteristics and speech quality parameters of hands-free terminals".
- [23] ITU-T Recommendation P.58: "Head and torso simulator for telephony".
- [24] ITU-T Recommendation G.111: "Loudness Ratings (LRs) in an international connection".
- [25] ITU-T Recommendation G.1020: "Performance parameter definitions for quality of speech and other voiceband applications utilizing IP networks".
- [26] ITU-T Recommendation P.57: "Artificial ears".
- [27] ITU-T Recommendation P.502: "Objective test methods for speech communication systems using complex test signals".
- [28] ITU-T Recommendation P.51: "Artificial mouth".
- [29] ETSI TBR 038: "Public Switched Telephone Network (PSTN); Attachment requirements for a terminal equipment incorporating an analogue handset function capable of supporting the justified case service when connected to the analogue interface of the PSTN in Europe".
- [30] ITU-T Recommendation G.131: "Talker echo and its control".
- [31] ETSI ETS 300 540: "Digital cellular telecommunications system (Phase 2) (GSM); Transmission planning aspects of the speech service in the GSM Public Land Mobile Network (PLMN) system (GSM 03.50)".
- [32] ITU-T Recommendation O.41: "Psophometer for use on telephone-type circuits".
- [33] ITU-T Recommendation P.360: "Efficiency of devices for preventing the occurrence of excessive acoustic pressure by telephone receivers and assessment of daily noise exposure of telephone users".

2.2 Informative references

The following referenced documents are not essential to the use of the present document but they assist the user with regard to a particular subject area. For non-specific references, the latest version of the referenced document (including any amendments) applies.

- [i.1] IETF RFC 791 (STD 5): "Internet Protocol".
- [i.2] IETF RFC 768 (STD 6): "User Datagram Protocol".
- [i.3] IETF RFC 3550: "RTP: A Transport Protocol for Real-Time Applications".
- [i.4] ETSI TBR 008 (1998): "Integrated Services Digital Network (ISDN); Telephony 3,1 kHz teleservice; Attachment requirements for handset terminals".
- [i.5] ETSI TBR 010: "Digital Enhanced Cordless Telecommunications (DECT); General terminal attachment requirements: Telephony applications".
- [i.6] ETSI TR 101 178: "Digital Enhanced Cordless Telecommunications (DECT); A High Level Guide to the DECT Standardization".
- [i.7] ETSI ETR 043: "Digital Enhanced Cordless Telecommunications (DECT); Common Interface (CI); Services and facilities requirements specification".
- [i.8] ETSI ES 202 737: "Speech Processing, Transmission and Quality Aspects (STQ); Transmission requirements for narrowband VoIP terminals (handset and headset) from a QoS perspective as perceived by the user".
- [i.9] ETSI ES 202 738: "Speech Processing, Transmission and Quality Aspects (STQ); Transmission requirements for narrowband VoIP loudspeaking and handsfree terminals from a QoS perspective as perceived by the user".

- [i.10] ETSI ES 202 739: "Speech Processing, Transmission and Quality Aspects (STQ); Transmission requirements for wideband VoIP terminals (handset and headset) from a QoS perspective as perceived by the user".
- [i.11] ETSI ES 202 740: "Speech Processing, Transmission and Quality Aspects (STQ); Transmission requirements for wideband VoIP loudspeaking and handsfree terminals from a QoS perspective as perceived by the user".
- [i.12] ETSI I-ETS 300 245-6: "Integrated Services Digital Network (ISDN); Technical characteristics of telephony terminals; Part 6: Wideband (7 kHz), loudspeaking and hands free telephony".
- [i.13] ITU-T Recommendation G.113 (2007): "Transmission impairments due to speech processing".
- [i.14] ITU-T Recommendation G.107 (2005): "The E-model, a computational model for use in transmission planning".
- [i.15] ITU-T Recommendation G.108 (1999): "Application of the E-model: A planning guide".
- [i.16] ITU-T Recommendation G.109 (1999): "Definition of categories of speech transmission quality".
- [i.17] ITU-T Recommendation G.729: "Coding of speech at 8 kbit/s using conjugate-structure algebraic-code-excited linear prediction (CS-ACELP)".
- [i.18] ITU-T Recommendation G.101 (2003): "The transmission plan".
- [i.19] ITU-T Recommendation G.164 (1988): "Echo suppressors".
- [i.20] ITU-T Recommendation G.165 (1993): "Echo cancellers".
- [i.21] ITU-T Recommendation G.168 (2007): "Digital network echo cancellers".
- [i.22] ETSI EG 202 396-1: "Speech Processing, Transmission and Quality Aspects (STQ); Speech quality performance in the presence of background noise; Part 1: Background noise simulation technique and background noise database".
- [i.23] IEEE 802.11: "Standard for Information Technology - Telecommunications and Information Exchange Between Systems - Local and Metropolitan Area Networks - Specific Requirements - Part 11: Wireless LAN Medium Access Control (MAC) and Physical Layer (PHY) Specifications".
- [i.24] IEEE 802.3: "Standard for Information Technology - Telecommunications and Information Exchange Between Systems - Local and Metropolitan Area Networks - Specific Requirements - Part 3: Carrier Sense Multiple Access with Collision Detection (CSMA/CD) Access Method and Physical Layer Specifications".
- [i.25] ITU-T Recommendation Y.1541: "Network performance objectives for IP-based services".

3 Definitions, symbols and abbreviations

3.1 Definitions

For the purposes of the present document, the following terms and definitions apply:

2-wire interface: in the context of the present document, it means the telephony analog interface over 2-wires used in the local loop

4-wire interface: in the context of the present document, 4-wire interface means any digital or analog interface with separate channels for both directions, irrespective of the physical transmission technology

NOTE: In most cases it refers to ISDN digital interface.

artificial ear: device for the calibration of earphones incorporating an acoustic coupler and a calibrated microphone for the measurement of the sound pressure and having an overall acoustic impedance similar to that of the median adult human ear over a given frequency band

artificial mouth: device consisting of a loudspeaker mounted in an enclosure and having a directivity and radiation pattern similar to those of the average human mouth

artificial head: equipment including artificial ear(s) and artificial mouth

NOTE: Practical implementations are defined as HATS and LRGP (see the respective definitions).

audio types: sets of specifications defining the acoustic and audio transmission behaviour of any DECT device (i.e. PP or FP) involved in an audio service, for a given application scenario and desired performance level. Each audio type specifies the transmission levels, equalization, echo suppression and any other relevant acoustic and audio transmission parameters

codec: combination of an analog-to-digital encoder and a digital-to-analog decoder operating in opposite directions of transmission in the same equipment

diffuse field frequency response of HATS (sound pick-up): Difference, in dB, between the third-octave spectrum level of the acoustic pressure at the ear-Drum Reference Point (DRP) and the third-octave spectrum level of the acoustic pressure at the HATS Reference Point (HRP) in a diffuse sound field with the HATS absent

E-model: transmission planning tool that provides a prediction of the expected voice quality, as perceived by a typical telephone user, for a complete end-to-end (i.e. mouth-to-ear) telephone connection under conversational conditions (see ITU-T Recommendation G.107 [i.14])

ear-Drum Reference Point (DRP): point located at the end of the ear canal, corresponding to the ear-drum position

echo canceller: voice operated device placed in the 4-wire portion of a circuit and used for reducing the cancelled end echo present on the send path by subtracting an estimation of that echo from the cancelled end

echo suppressor: (sometimes "acoustic echo suppressor") telecommunications device used to reduce the echo. Echo suppressors work by detecting if there is a voice signal going in one direction on a circuit, and then inserting a great deal of loss in the other direction

freefield reference point: point located in the free sound field, at least in 1,5 m distance from a sound source radiating in free air (in case of a head and torso simulator (HATS) in the center of the artificial head with no artificial head present)

freefield equalization: artificial head is equalized in such a way that for frontal sound incidence in anechoic conditions the frequency response of the artificial head is flat

NOTE: This equalization is specific to the HATS methodology.

Head And Torso Simulator (HATS) for telephonometry: manikin extending downward from the top of the head to the waist, designed to simulate the sound pick-up characteristics and the acoustic diffraction produced by a median human adult and to reproduce the acoustic field generated by the human mouth

Loudness Rating Guard-ring Position (LRGP): position of handset relative to guard-ring of artificial ear for loudness rating measurement

Mouth Reference Point (MRP): is located on axis and 25 mm in front of the lip plane of a mouth simulator

nominal setting of the volume control: when a receive volume control is provided, the setting which is closest to the nominal RLR of 2 dB

super-wideband speech: voice service with enhanced quality compared to PCM G.711 [13] and allowing the transmission of a maximum vocal frequency of at least 14 kHz

Talker's Echo Loudness Rating: loss of the speaker's voice sound reaching his ear as a delayed echo

uniform PCM: linear uniform Pulse Code Modulations with the necessary bit rate and resolution (number of bits) to handle the audio signals in each case according to the signal bandwidth, codec and audio requirements. It is used for definition of reference points.

NOTE: It does not mean 8 kHz x 8 bit (G.711) PCM.

wideband speech: voice service with enhanced quality compared to PCM G.711 [13] and allowing the transmission of a vocal frequency range of at least 150 Hz to 7 kHz

3.2 Symbols and abbreviations

For the purposes of the present document, the symbols and abbreviations given in ITU-T Recommendations P.10 [21], G.701 [11], EN 300 175-1 [1] and the following apply:

A/D	Analog/Digital
AAC	Advanced Audio Coding (MPEG)
ADPCM	Adaptive Differential Pulse Code Modulation
AH,R,dt	Attenuation Range in receiving direction during Double Talk
AH,S,dt	Attenuation Range in sending direction during Double Talk
BSS	Base Station Sub-system
CI	Common Interface
CLRR	Circuit Loudness Rating, Receiving
CLRS	Circuit Loudness Rating, Sending
CRFP	Cordless Radio Fixed Part
CSS	Composite Source Signal
D	D-value of terminal
D/A	Digital/Analog
dBm	absolute power level relative to 1 milliwatt, expressed in dB
dBm0	absolute power level in dBm referred to a point of zero relative level (0 dB point)
dBm0p	weighted dBm0, according to ITU-T Recommendation O.41 [32]
dBPa	sound pressure level relative to 1 Pa, expressed in dB
dBPa(A)	a-weighted sound pressure level relative to 1 Pa, expressed in dB
dBr	relative power level of a signal in a transmission path referred to the level at a reference point on the path (0 dBr point)
DECT	Digital Enhanced Cordless Telecommunications
DRP	ear Drum Reference Point
DTX	Discontinuous Transmission
e.m.f.	electromotive force
ER	Error Resilient (MPEG)
ERP	Ear Reference Point
ES	End System
EUT	Equipment Under Test
FP	Fixed Part
FT	Fixed radio Termination
GAP	Generic Access Profile
GSM	Global System for Mobile communications
HATS	Head And Torso Simulator
HFT	Hands-free Termin
IC	Integrated Circuit
I_e	equipment Impairment factor
ISDN	Integrated Services Digital Network
LD	Low Delay (MPEG)
LL_e	Local echo Loss
LRGP	Loudness Rating Guard-ring Position
$L_{S,min}$	minimum activation level (Sending Direction)
LSTR	Listener SideTone Rating
MIPS	Million of Instructions per Second
MOS	Mean Opinion Score
MPEG	Moving Picture Expert Group
MRP	Mouth Reference Point
MSB	Most Significant Bit

MSC	Mobile Switching Centre
N	Newton
NG-DECT	New Generation DECT
NLP	Non-Linear Processor
NWK	NetWorK
PABX	Private (Automatic) Branch eXchange
PCM	Pulse Code Modulation
PLC	Packet Loss Concealment
POI	Point Of Interconnect
PP	Portable Part
PSTN	Public Switched Telephone Network
PT	Portable radio Termination
ReFP	Reference Fixed Part
REP	REpeater Part
RePP	Reference Portable Part
RF	Radio Frequency
RFP	Radio Fixed Part
RLR	Receiving Loudness Rating
RLR _H	Receiving Loudness Rating of the Handset
rms	root mean square
SL	Linear input Signal, see ITU-T Recommendation G.726 [12]
SLR	Sending Loudness Rating
SLR _H	Sending Loudness Rating of the Handset
STM _R	SideTone Masking Rating
T	Delay
TA	Terminal Adaptors
TCL	Terminal Coupling Loss
TCL _w	weighted Terminal Coupling Loss
TDMA	Time Division Multiple Access
TELR	Talker's Echo Loudness Rating
Tr,S,min	built-up time (Sending Direction)
VAD	Voice Activity Detection
VoIP	Voice over Internet Protocol
WMOPS	Weighted Millions of Operations Per Second
WRS	Wireless Relay Station

4 Configurations

4.1 Reference configuration

4.1.1 Basic configuration

The basic reference configuration for voice transmission over DECT is shown in figure 4.1.

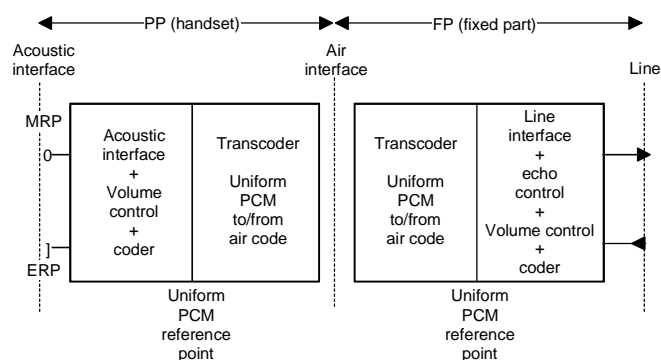

Figure 4.1: Basic reference configuration

The PP and the FP are delimited by physical interfaces:

- Acoustic: from the PP towards the speaker-listener, with the Ear and Mouth Reference Points (ERP and MRP).
- Air(RF): the interface between PP and FP.
- Line: the interface from the FP towards the network.

Uniform PCM reference points shall be introduced in both the PP and the FP to materialize the limits of the transmission segment which is affected by the air interface coding scheme. This allows the transmission requirements to be specified independently from the coding at the air interface. The various transcoding algorithms are level-transparent, i.e. with an encoder and decoder connected in tandem, the "levels" of the digital signals at the uniform PCM input of the encoder and output from the decoder are identical.

NOTE 1: The uniform PCM reference points are elements of the descriptive model and may physically exist in a particular implementation or not. For example A/D conversion, transcoding or signal processing without PCM conversion may be used or the reference points may be embedded within an IC, and thus will not be physically accessible.

NOTE 2: Uniform PCM in the context of the present document means linear PCM with the necessary bit rate and resolution (number of bits) to handle the audio signal according to the codec bandwidth and the audio requirements specified in the present document. It does not mean 8 kHz x 8 bit (ITU-T Recommendation G.711 [13]) PCM. Note that the present document provides specification for wideband and super-wideband services.

Each of the three sections thus delimited deals with distinct functions:

- the PP electro-acoustic section (between acoustic interface and PP uniform PCM reference point) which includes the acoustic interface, the volume control and the analog to digital conversion;
- the air-code section (between PP and FP uniform PCM reference points) considers the transcoding between uniform PCM and the air-code, as well as the transmission over the air interface;
- the FP line interface section (between FP uniform PCM reference point and line interface) comprises the interface to the line, digital or analog, and the FP voice processing, e.g. echo control.

Typically, the transmission features conform to TBR 008 [i.4] for the PP electro-acoustic section, and the line interface section in the case of digital line interface. In the case of analog interface, the FP performs the digital/analog conversion and the adaptation to the 2-wire analog line interface according to the requirements described in clauses 7.3.4 and 7.6.3 of the present document.

4.1.2 Portable Part (PP)

4.1.2.1 Functional organization

Figure 4.2 represents the basic functional organization of a PP from the voice transmission point of view.

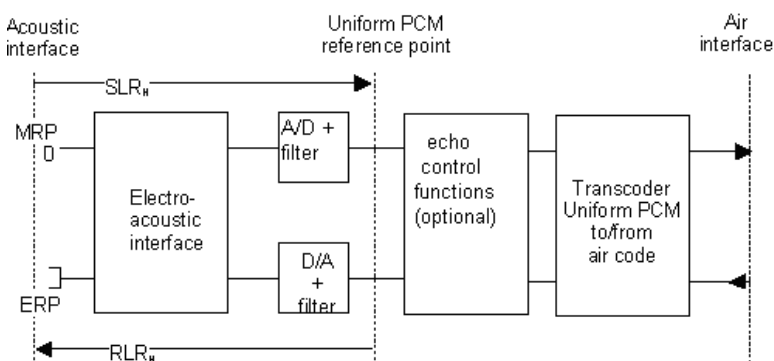

Figure 4.2: PP functional organization

The various functions represented in figure 4.2 are:

- a) the electro-acoustic function, which performs the interface to the transducers and the volume control. The Handset Loudness Ratings (SLR_H) and (RLR_H) are defined between the acoustic interface and the uniform PCM reference point;
- b) the analog to digital and digital to analog coding to the uniform PCM reference point;
- c) optional echo control functions may be implemented between the PCM reference point and the transcoder, if needed, in order to fulfil the TCLw requirements described in the present document;
- d) the transcoder between uniform PCM and air-code.

NOTE 1: For high echo loss, the implementation of an echo control function could be necessary in order to process the acoustic echo produced by handsets (mechanical and/or acoustical coupling) with low TCLw requirements (PP types 1a or 2a, see clause 7).

NOTE 2: See also notes 1 and 2 of clause 4.1.1.

4.1.2.2 Volume control

The volume control facility is optional, and can be implemented in a number of different ways:

- 1) in the simplest implementation, it affects only the receiving level and is under the manual control of the PP user;
- 2) the volume adjustment may also be adaptive, e.g. taking into account the average level of ambient noise at the MRP;
- 3) the volume control may affect both receiving and sending levels in opposite directions. This has the advantage of reducing the influence on the terminal coupling loss when the receive volume is increased. Such an implementation would fit a noisy environment, as the need for an increased receiving volume is likely to come from a loud ambient noise, and it is then combined with a loud speech level.

4.1.3 Fixed Part (FP)

4.1.3.1 Digital interface

Figure 4.3 shows the functional model of a FP with a digital interface.

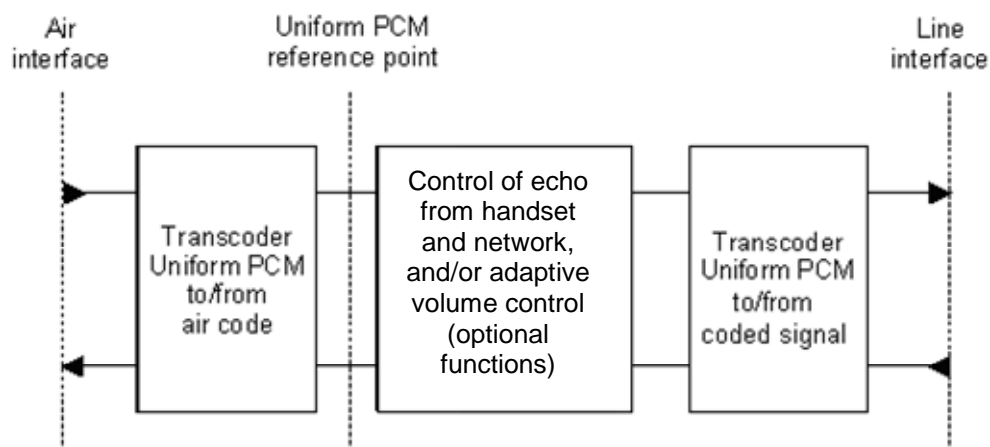

Figure 4.3: FP functional model including optional functions (echo control and/or adaptive volume control)

The various functions represented in figure 4.3 are:

- a) transcoder between air-code and uniform PCM;
- b) optional echo control functions which process echoes coming back from both the handset and/or from the network;
- c) optional adaptive volume control function;
- d) transcoder from uniform PCM to the coded signal used in the line interface.

NOTE 1: See also notes 1 and 2 of clause 4.1.1.

NOTE 2: For codec G.711 over the line interface, the transcoder (from uniform PCM to line interface) consist only on the application of A or μ laws.

Figure 4.4 shows a simplified functional model of a FP when:

- 1) no echo control or adaptive volume control are used; and
- 2) there is no need to refer to the internal PCM reference point.

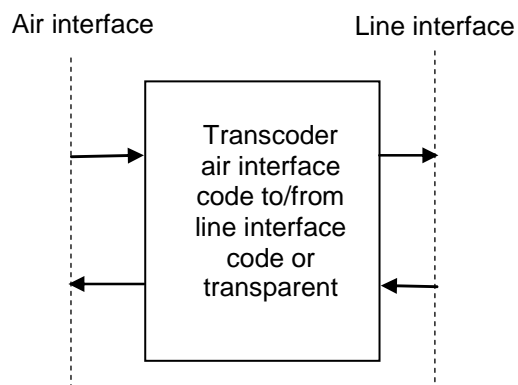

Figure 4.4: FP simplified functional model without optional functions

The various functions represented in figure 4.4 are:

- a) transcoder between air-code and uniform PCM;
- b) transcoder from uniform PCM to coded signal towards the line interface.

NOTE 3: See also notes 1 and 2 of clause 4.1.1.

NOTE 4: In the particular case when air interface and line interface codes are identical, no transcoding is necessary, and this simplified model becomes transparent.

4.1.3.2 Analog interface

The implementation of a FP with an analog interface is shown in figure 4.5.

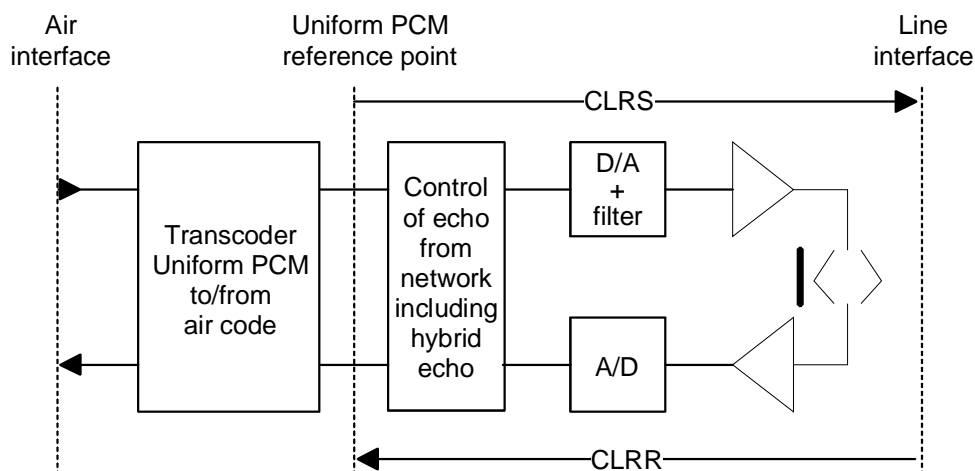

Figure 4.5: FP with an analog interface

The various functions represented in figure 4.5 are:

- the line interface comprises the digital to analog coder-decoder and the adaptation to the line, that can be either 2- or 4-wire. The Circuit Loudness Ratings (CLRR and CLRS) are defined between uniform PCM reference point and the line interface;
- in the case of a 2-wire line, the network echo controller deals both with the local hybrid echo and the far end network echo.

4.1.3.3 FP adaptive volume control

An adaptive dual volume adjustment, as described in clause 4.1.2.2, may optionally be implemented into the FP, for base stations where the associated PPs may be used in a noisy environment (e.g. public access).

4.2 Test configurations

A complete DECT system comprises a FP and a PP. It is a requirement that either the complete system or each of the two separate parts shall be capable of being tested (see EN 300 176-2 [10]).

5 Encoding

This clause describes the different speech and audio codecs supported by DECT.

5.1 32 kbit/s full term (ADPCM) G.726

5.1.1 Algorithm

The speech coding algorithm shall conform to ITU-T Recommendation G.726 [12] for 32 kbit/s Adaptive Differential Pulse Code Modulation (ADPCM).

The A-law companding and synchronous tandem adjustment may be omitted in FPs with an analog line interface and in PPs.

NOTE: ITU-T Recommendation G.726 [12] 32 kbit/s ADPCM codecs support the use of the voice channel for telefax of group 2 and group 3. For group 3 the data speed, which is automatically negotiated, is in practice normally limited to 9,6 kbit/s.

5.1.2 Bit sequence

The ADPCM words comprised in each burst shall be transmitted in chronological order, and with the most significant bit transmitted first within each word.

5.1.3 Characteristics of G.726 ADPCM codec

The characteristics of G.726 [12] ADPCM codec are summarized in table 5.1.

Table 5.1: ITU-T Recommendation G.726 [12] ADPCM Speech codec

Standard	G.726 [12]
	ADPCM
Date	1990
Bandwidth	300 Hz to 3,4 kHz
Sampling rate	8 kHz
Bit rate (kbit/s)	32
Embedded Scalability	No
Type	ADPCM
Frame size	0,125 ms
Algorithmic Delay	0,125 ms
Complexity	≈ 12 MIPS
RAM (KB)	≈ 0,3

5.2 64 kbit/s PCM G.711

5.2.1 Algorithm

ITU-T Recommendation G.711 [13] for 64 kbit/s Pulse Code Modulation (PCM) Narrow Band codec may be optionally implemented in DECT devices in order to improve quality of narrowband communications: slightly higher intrinsic voice quality and no transcoding for PSTN calls.

The two variants of G.711 [13], A-law and μ -law may be supported.

NOTE: G.711 [13] 64 kbit/s PCM codec support the use of the voice channel for any telefax or modem service, including 56 kbit/s modems.

5.2.2 Bit sequence

The same rules for bitstream ordering as for G.726 (clause 5.1.2) apply: chronological order and Most Significant Bit (MSB) first.

5.2.3 Characteristics of G.711 PCM codec

The characteristics of G.711 PCM codec are summarized in table 5.2.

Table 5.2: ITU-T Recommendation G.711 [13] PCM Speech codec

Standard	G.711 [13]
	PCM
Date	1972
Bandwidth	300 Hz to 3,4 kHz
Sampling rate	8 kHz
Bit rate (kbit/s)	64
Embedded Scalability	No
Type	LOG PCM
Frame size	0,125 ms
Algorithmic Delay	0,125 ms
Complexity	≈ 0,01 MIPS
RAM (KB)	≈ 0

5.2.4 Automatic detection of FAX/modem tone and switch to G.711

Systems implementing G.711 [13] and other codecs, could implement the detection of the 1 100 Hz (fax Calling Tone), 1 300 Hz (modem) and 2 100 Hz (fax/modem answer) audio tones and the in-call switching between the other codec and G.711.

5.3 Wideband speech codec G.722 at 64 kbit/s

ITU-T Recommendation G.722 codec [14] is chosen as mandatory wideband codec for New Generation DECT in order to greatly increase the voice quality by extending the bandwidth from narrowband to wideband. G.722 provides a high wideband quality at bit rate of 64 kbit/s with low complexity and very low delay.

5.3.1 Algorithm

DECT devices supporting wideband voice (16 kHz frequency sampling) shall comply with ITU-T Recommendation G.722 [14] speech coding recommendation at 64 kbit/s.

ITU-T Recommendation G.722 [14] supports a frequency range of 50 Hz to 7 kHz. The extension of the bandwidth from narrowband 300 Hz to 3,4 kHz to wideband 50 Hz to 7 kHz greatly increases the voice quality.

5.3.2 Bit sequence

The same rules for bitstream ordering as for G.726 (see clause 5.1.2) apply: chronological order and Most Significant Bit (MSB) first.

5.3.3 Characteristics of G.722 wideband codec

G.722 [14] provides a high wideband quality at bit rate of 64 kbit/s with limited complexity and very low delay. The characteristics of G.722 wideband codec are summarized in table 5.3.

Table 5.3: ITU-T Recommendation G.722 [14] Wideband Speech codec

Standard	G.722 [14] SB-ADPCM
Date	1988
Bandwidth	50 Hz - 7 kHz
Sampling rate	16 kHz
Bit rate (kbit/s)	64, 56, 48 (see note)
Embedded Scalability	Yes
Type	Sub-Band ADPCM
Frame size	0,125 ms
Algorithmic Delay	1,625 ms
Complexity	≈ 10 MIPS
RAM (KB)	1
NOTE: Bit rate of 64 kbit/s shall be used for NG-DECT.	

5.3.4 Optional Packet Loss Concealment algorithm (PLC)

ITU-T Recommendation G.722 Appendix III [15] and Appendix IV [16] are optional packet loss concealment (PLC) solutions extending G.722 decoder [14]. They may be implemented to improve voice quality in degraded transmission conditions where packets/frames may be lost (in IP network or on DECT air interface).

Appendices III and IV meet the same quality requirements but with two different quality/complexity trade offs:

- Appendix III [15] aims at maximizing the robustness at a price of additional complexity.
- Appendix IV [16] offers an optimized complexity/quality trade off with almost no additional complexity compared with G.722 normal decoding (+0,07 WMOPS).

ITU-T formal subjective tests have demonstrated that both Appendices provide an important quality improvement compared with a basic PLC reference solution (frame repeat based): in 1 %, 3 % and 6 % Frame Error Rate conditions (bursty or random), quality is increased by 0,5 MOS to 0,7 MOS.

Since G.722 does not incorporate any mechanism to cope with lost frames/packets, use of a PLC algorithm is strongly recommended to avoid annoying effects in case of packet/frame losses.

5.4 Wideband speech codec G.729.1 up to 32 kbit/s

5.4.1 Algorithm

ITU-T Recommendation G.729.1 [17] ("G.729EV") codec operating up to 32 kbit/s bit rate, is supported as an optional codec for wideband speech in order to provide similar wideband quality at half the bit rate of G.722 [14]. This allows a better transport efficiency on network side and DECT air interface (fits in one DECT full slot). Further bandwidth saving is possible since the codec is scalable and can operate at much lower bit rates by simple truncation of the bitstream, however with reduction of quality. In addition, G.729.1 [17] allows seamless interoperability with largely deployed VoIP networks and terminals implementing ITU-T Recommendation G.729 [17] narrowband codec.

On the other hand, this codec requires more processing power and adds more delay than 64 kbit/s G.722.

5.4.2 Bit sequence

The bitstream ordering shall comply with the order defined in ITU-T Recommendation G.729.1 [17]. MSB is transmitted first.

5.4.3 Characteristics of G.729.1 codec

G.729.1 [17] encodes signals in frames of 20 ms at bitrates of 8 kbit/s, and from 12 kbit/s to 32 kbit/s per steps of 2 kbit/s, both in narrowband or in wideband from 14 kbit/s. The supported bit rate in DECT is 30 kbit/s in wideband mode.

The codec is scalable and delivers an embedded bitstream that can be truncated at any point of the transmission path to dynamically reduce the bit rate and further optimize the bandwidth usage (down to 8 kbit/s for narrowband and 14 kbit/s for wideband with 12 possible intermediate bit rates).

At the bit rate of 8 kbit/s G.729.1 [17] is fully bitstream compliant with ITU-T Recommendation G.729 [17]. As a consequence it can fully interoperate with largely deployed VoIP networks and terminals implementing G.729/G.729AB narrowband codecs [i.17].

G.729.1 [17] can either operate in wideband (16 kHz frequency sampling input/output signals) or in narrowband (8 kHz frequency sampling input/output signals).

Table 5.4: ITU-T Recommendation G.729.1 [17] Wideband Speech codec

Standard	G.729.1 [17]
Date	2006
Bandwidth	50 Hz to 4 kHz 50 Hz to 7 kHz (bit rates \geq 14 kbit/s)
Sampling rate	8 kHz / 16 kHz
Bit rate (kbit/s)	8, 12, 14, 16, 18, 20, 22, 24, 26, 28, 30, 32
Embedded Scalability	Yes (interoperable at 8 kbit/s with G.729)
Type	EV-CELP Time Domain Bandwidth Extension (TDBWE) Transform Coding (MDCT)
Frame size	20 ms
Algorithmic Delay	48,9375 ms
Complexity	35,8 WMOPS based on new STL2005 (34,7 WMOPS based on STL2000)
RAM (KB)	17,4

5.4.4 Packet Loss Concealment algorithm (PLC)

ITU T Recommendation G.729.1 [17] incorporates a high efficiency packet loss concealment mechanism.

5.4.5 Supported bit rate in DECT

The nominal supported bit rate of codec G.729.1 [17] over DECT is 30 kbit/s when transported used in combination with DLC service LU12, encapsulated as clause E.1 (see EN 300 175-4 [4]). The resulting LU12 frames are transported over 32 kbit/s DECT channels.

Under some circumstances the codec may produce less bit rate than the 30 kbit/s. This is also supported by the LU12 encapsulation mechanism (see EN 300 175-4 [4], clause E.1).

Other bitrates and transports are for further study.

5.5 Super-wideband MPEG-4 speech and audio coding

5.5.1 Algorithm

MPEG-4 ER AAC-LD operating at sampling rates of 48 kHz or 24 kHz is supported as optional codec for wideband and super-wideband speech. MPEG-4 ER AAC-LD is designed for high quality communication application including all kind of audio signals e.g. speech and music. It provides an audio bandwidth around 14 kHz at a bit rate of 64 kbit/s.

On the other hand, this codec requires more processing power and adds more delay than G.722 [14].

MPEG 4 ER AAC-LD (Error Resilient, Low Delay AAC profile) is standardized as an audio profile [18] of MPEG-4 (ISO/IEC 14496-3 [19]).

DECT will support two modes: 64 kbit/s and 32 kbit/s with characteristics defined in clauses 5.5.2 and 5.5.3. The DECT configuration shall follow the limitations defined in [18].

5.5.2 64 kbit/s, MPEG-4 ER AAC-LD codec

MPEG-4 ER AAC-LD at 64 kbit/s is designed for high quality communication applications including all kind of audio signals e.g. speech and music. It provides an audio bandwidth of about 14 kHz at this bit rate of 64 kbit/s and a subjective quality close to FM radio. The packet size shall be 10 ms and algorithmic delay is 20 ms.

Table 5.5: 64 kbit/s, 14 kHz MPEG-4 ER AAC-LD Audio codec

Standard	MPEG-4 ER AAC-LD 64 kbit/s
Date	2000/2006
Recommended Bandwidth	14 kHz
Sampling rate	48 kHz
Bit rate (kbit/s)	64
Embedded Scalability	no
Type	perceptual audio codec
Frame size	10 ms (480 samples)
Algorithmic Delay	20 ms
Example Complexity	~25 MIPS (encoder) ~10 MIPS (decoder)
Example RAM (KB)	~28 KB (encoder) ~13 KB (decoder) IO Buffer not included

5.5.3 32 kbit/s, MPEG-4 ER AAC-LD codec

MPEG-4 ER AAC-LD may also be optionally used in 32 kbit/s mode. It provides a bandwidth of about 11,5 kHz. The packet size shall be 20 ms and the algorithmic delay is 40 ms.

Table 5.6: 32 kbit/s, 11,5 kHz MPEG-4 ER AAC-LD Audio codec

Standard	MPEG-4 ER AAC-LD 32 kbit/s
Date	2000/2006
Recommended Bandwidth	11,5 kHz
Sampling rate	24 kHz
Bit rate (kbit/s)	32
Embedded Scalability	No
Type	Perceptual audio codec
Frame size	20 ms (480 samples)
Algorithmic Delay	40 ms
Example Complexity	~13 MIPS (encoder) ~5 MIPS (decoder)
Example RAM (KB)	~28 KB (encoder) ~13 KB (decoder) IO Buffer not included

5.6 Other codings

Other narrow-band or wide-band codecs could be added in the future. When introducing a new coding the following speech performance characteristics shall be reviewed:

- frequency response;
- distortion;
- delay; and
- if the latter is widely affected, terminal coupling loss and network echo control.

6 Transmission aspects

6.1 Relative level

The digital line interface is a 0 dBr point according to ITU-T Recommendation G.101 [i.18]. As the various digital transcoding algorithms are essentially loss-less, the relative level is constant over the whole digital path in the PP and the FP.

6.2 Acoustic reference level

The acoustic reference level is defined as the acoustic level which corresponds to a level of -10 dBm0 at the digital interface.

6.3 Volume control

Unless stated otherwise, if a user-controlled volume control is provided at the PP, the requirements apply for nominal position of the volume control, and the compliance tests shall be carried out at the nominal setting of this volume control.

7 Audio specifications

7.1 Overall description

7.1.1 Introduction to DECT audio specifications

The purpose of the Audio specifications is defining precisely the acoustic behaviour of any DECT device, in order to ensure:

- Homogeneous end-user perception regarding acoustic levels and equalization between devices of different manufacturers.
- A minimum level of acoustic quality is guaranteed for all devices compliant to a DECT specification.
- Complete interoperability between DECT devices of different manufacturers.
- Control of the acoustic quality and behaviour in the conformance test process.

7.1.2 Introduction to the audio types

Due to the different parts and multiple application scenarios of DECT systems, the DECT Audio specifications have been implemented by means of the definition of models called "audio types". Each audio type is a complete set of detailed audio specifications for a given DECT component (i.e. PP or FP), application scenario and desired performance level.

The Audio types are sets of specifications defining the acoustic and audio transmission behaviour of any DECT device involved in an audio service. Each type specifies the transmission levels, equalization, echo suppression and any other relevant acoustic and audio transmission parameters.

The current audio types are listed in clause 7.1.3.

In order to specify the acoustic behaviour of any DECT component or system, one or more audio types may be referred. This can be done in the individual specification of products, or in DECT Application Profile specifications. The audio types are features for the Application Profiles.

This specification model is easily expandable in the future without disturbing the specification of existing systems. This may be done by creating new audio types.

The Audio Features are applicable to all DECT devices involved in audio services. It includes:

- DECT handsets (PPs), with acoustic interface.
- DECT handsets (PPs) with acoustic interface operating in handsfree mode.
- DECT PPs with external electrical audio interface.
- Speaker handsfree or headset accessories connected to a PP.
- DECT RFPs, with any network interface.
- DECT RFPs operating an internal call or conference between two or more DECT PPs.
- DECT repeaters (REP).

The Audio types for devices with acoustic interface (handsets, handsfree and headsets) are acoustic specifications with an acoustic air interface at the user side. These are defined and tested using the classic artificial head methodology (see ITU-T Recommendation P.57 [26]) or the HATS methodology (see ITU-T Recommendation P.58 [24]).

The Audio types for devices without acoustic interfaces (all DECT RFP, repeaters, etc.) are electrical transmission specifications introducing features like equalization, echo suppression or artificial echo insertion.

All Audio types include a detailed test specification that allows the conformance test of any device declaring compliance with it. Test specifications are described in EN 300 176-2 [10].

A DECT physical device may implement several Audio types. This is the case, for instance of a wideband (7 kHz) device that also supports narrowband (3,1 kHz) service.

7.1.3 List of Audio types

Table 7.1 summarizes the list Audio transmission Types defined in the present document.

Table 7.1: List of Audio types

Applicable to:	Type nr.	Type name	Clause	Remarks
PP	0	Reference PP (RePP) narrowband	7.2.2	For test purposes
	1a	"Classic" GAP handset narrowband	7.2.3	This type could produce echo issues in combination with VoIP or "long delay" networks.
	1b	"Improved" GAP handset narrowband	7.2.4	
	1c	HATS tested, "standard" narrowband handset	7.2.5	
	1d	HATS tested, "improved" narrowband handset	7.2.6	
	3a	HATS tested, "standard" narrowband loudspeaking and handsfree feature	7.2.7	
	3b	HATS tested, "improved" narrowband loudspeaking and handsfree feature	7.2.8	
	2a	ITU-T P.311 [20] tested, wideband handset or headset	7.2.9	Type 2a could produce echo issues in combination with VoIP or long delay networks
	2b	HATS tested, "standard" wideband handset or headset	7.2.10	
	2c	HATS tested, "improved" wideband handset or headset	7.2.11	
	4a	HATS tested, "standard" wideband loudspeaking and handsfree feature	7.2.12	
	4b	HATS tested, "improved" wideband loudspeaking and handsfree feature	7.2.13	
	5a	Super-wideband 14 kHz handset or headset	7.2.14	
	5b	Super-wideband 14 kHz handsfree	7.2.15	

Applicable to:	Type nr.	Type name	Clause	Remarks
	6	PPs with external 2 wire, 3,1 kHz telephony interface	7.2.16	See also annex B
FP	0	Reference FP (ReFP)	7.3.1	For test purposes
	1a	"classic" Fixed Part for ISDN network	7.3.2	
	1b	"new" Fixed Part for ISDN Network	7.3.3	
	2	FP with analog 2-wire interface, 3,1 kHz service	7.3.4	
	3	VoIP narrowband Fixed Part	7.3.5	
	4	ISDN wideband Fixed Part	7.3.6	
	5	VoIP wideband Fixed Part	7.3.7	
	6a	FP handling an Internal call inside a DECT FP (any service)	7.3.8	Internal call
	6b	FP handling an n-party conference inside a DECT FP (any service)	7.3.9	Internal conference bridge
REP	7	DECT Repeater part (REP)	7.3.10	

7.1.4 Audio types for Portable Parts

The **type 1a** configuration is a general purpose 3,1 kHz telephony audio feature. This was the only audio specification for narrowband PPs until the standard revision performed in 2008. It provides 3,1 kHz (300 Hz to 3,4 kHz) telephony service with a subjective quality comparable to fixed phones, when connected via PSTN/ISDN network.

The increasing use of internet and VoIP technologies in the networks forced to a revision of the specification, increasing the value of the TCLw parameter in order to avoid echo issues when used over long delay networks. Types 1b, 1c and 1d were created.

Type 1b is identical to type 1a, except for an increased value of TCLw and parameters ensuring full duplex working which allows perfect operation even over long delay networks, like VoIP.

Types 1c and 1d (respectively standard and improved) correspond to narrowband handset and headset developed with new methods of measurement using HATS instead of artificial head. Requirements take into account specificities of VoIP network.

Types 3a and 3b (respectively standard and improved) concerning narrowband loudspeaking and handsfree function.

Type 2a introduces wideband (7 kHz) voice using ITU-T Recommendation P.311 [20] for requirements and testing.

Types 2b and 2c (respectively standard and improved) correspond to wideband handset and headset developed with new methods of measurement using HATS instead of artificial head. Requirements take into account specificities of VoIP networks.

Types 4a and 4b (respectively standard and improved) concerning loudspeaking and handsfree function for 7 kHz (wideband) telephony service.

Types 5a and 5b concerning respectively handset or headsets (5a) and loudspeaking handsfree function (5b) for 14 kHz superwideband audio service.

Type 6 is a PP with external 2-wire analog interface providing 3,1 kHz (narrowband) telephony service. It intended for Wireless local Loop applications,

NOTE 1: Type 1a could produce echo issues in combination with VoIP or long delay networks. Types 1b, 1c or 1d are recommended for this scenario.

NOTE 2: Type 2a may produce echo issues in combination with VoIP or long delay networks. Types 2b and 2c are recommended for this scenario.

For handsfree devices (types 3a, 3b, 4a and 4b) there is distinction depending of if it is a desktop or a handheld handsfree device.

7.1.5 Audio types for Fixed Parts

The FP **type 1a** defines the audio transmission behaviour of a general purpose 3,1 kHz telephony Fixed Part with ISDN (or digital network) interface. This type is the classic specification of DECT FPs with ISDN interface that was the only one until the standard revision performed in 2008. It provides 3,1 kHz (300 Hz to 3,4 kHz) telephony service with a subjective quality comparable to fixed phones, when connected via ISDN network.

The increasing use of internet and VoIP technologies in the networks forced to a revision of the present document. It was identified that echo control architecture in type 1a may decrease quality in some scenarios. Consequently, the FP type 1b "new ISDN (narrowband) FP" was created. The modification compared to type 1a consists on a new strategy of PP echo control.

Type 2 audio type is for FPs with PSTN interface providing general purpose 3,1 kHz telephony.

Type 3 audio type is for FPs with VoIP interface providing 3,1 kHz telephony.

Type 4 audio type is for FPs with ISDN interface providing wideband 7 kHz communication.

Type 5 audio type is for FPs with VoIP interface providing wideband 7 kHz communication.

Type 6a configuration is for internal call inside a DECT FP or a DECT system without any external interface.

Type 6b configuration is for the case of 3 or multi-party conference inside a DECT FP or a DECT system with or without an external interface.

Type 7 configuration is for the DECT Repeater Part (REP) if used in a DECT system.

7.1.6 Complete DECT system

For a complete DECT system (PP + FP), at least one PP audio type and one FP audio type should be specified. It is possible, however, to support more than one type at each part.

7.1.7 Structure of the specification of the audio types

Each audio type consists on a top-level description and series of specific technical requirements described in detail in separate clauses. All audio types are introduced and top-level described in clauses 7.2 (types for Portable Parts) and 7.3 (types for Fixed Parts). The overall description describes the applicability scenario (codecs, interfaces, etc.) and contains references to specific sub-clauses in clauses 7.4, 7.5 and 7.6 where the detailed specification of each technical requirement may be found.

Table 7.2 summarizes the specification structure. It includes the list of specific technical requirements that are included within each audio type. This table contains the following information and columns:

- **Audio type name:** in the header of each section in the table;
- **CH (Change History):** this column is included for traceability reasons. An "X" indicates that the requirement is new or that there have been any modification compared with the previous audio specification (the present document);
- **Clause number:** indicates the clause that contains the detailed specification of the requirement;
- **Requirement:** it is the requirement name. It matches with the title of the clause describing it;
- **M/O (mandatory/optional) column:** indicates the status of the requirement:
 - M: means that this requirement is always part of the type;
 - O: indicates that this requirement is an optional requirement that may be included with the type (compatible) or not;
- **S/I:** indicates that there is a difference between standard and improved types (applies only to HATS defined PP types);
- **Comments:** for additional comments when needed.

In application profiles a reference in an status table to an audio type means automatically the support of all "M" requirements (unless an exception is specifically noted). On the other hand "O" requirements should be specifically listed in the status table or referred in the description text, where the application profile may set the status for them.

For FP audio types, the type of the network is implicit in the type name.

For PP audio types, the type of network is irrelevant since the interface is always the DECT air interface. There is no restriction: all DECT PP types are compatible with all FP types of the same audio service.

NOTE 1: However, there can be some performance restrictions in some combinations.

Note that there are three audio services: narrowband (3,1 kHz), wideband (7 kHz) and super-wideband (14 kHz).

NOTE 2: The super-wideband specifications are listed but not developed in this revision.

Table 7.2: Detailed requirements included within each audio type (PPs)

CH	Clause Number	Requirement	M/O	S/I	Comments
Portable Part					
PP type 1a: "Classic GAP" handset					
	7.2.3.3	General specification	M		
	7.5.1.1.1	Sending frequency response	M		
	7.5.1.1.2	Receiving frequency response	M		
	7.5.1.2.1	Nominal values for loudness ratings	M		
	7.5.1.2.2	User-controlled volume control in PP	M		
	7.5.1.2.3	PP adaptive volume control	O		
	7.5.1.3.1	Talker sidetone	M		
	7.5.1.3.2	Listener sidetone	M		
	7.5.1.4.1	Weighted Terminal Coupling Loss (TCLw)	M		
	7.5.1.4.2	Stability loss	M		
	7.5.1.5.1	Sending distortion	M		
	7.5.1.5.2	Receiving distortion	M		
	7.5.1.6.1	Out of band signals for sending	M		
	7.5.1.6.2	Out of band signals for receiving	M		
	7.5.1.7.1	Sending noise	M		
	7.5.1.7.2	Sending narrowband noise	M		
	7.5.1.7.3	Receiving noise	M		
	7.5.1.7.4	Level of sampling frequency (receiving)	M		
	7.5.1.8.1	Acoustic shock: continuous signal	M		
	7.5.1.8.2	Acoustic shock: peak signal	M		
	7.5.1.9	PP Delay	M		
	7.5.1.10	PP ambient noise rejection	O		
PP type 1b: Improved GAP handset					
X	7.2.4.3	General specification	M		
	7.5.1	All specs of type 1a also apply	M/O		See type 1a
X	7.5.2.1	Terminal coupling loss	M		
X	7.5.2.2	Attenuation Range in Sending Direction during Double Talk AH,S,dt	M		
X	7.5.2.3	Attenuation Range in Receiving Direction during Double Talk AH,S,dt	M		
X	7.5.2.4	Activation in Sending Direction	M		
X	7.5.2.5	Activation in Receiving Direction	M		

CH	Clause Number	Requirement	M/O	S/I	Comments
Portable Part					
PP type 1c and 1d: HATS-tested narrowband handset					
X	7.2.5.3/7.2.6.3	General specification	M	X	
X	7.5.3.1	PP frequency response	M	X	
X	7.5.3.2.1	PP sending and receiving loudness ratings: nominal values	M		
	7.5.3.2.2	User controlled volume control in PP	M		
	7.5.3.2.3	PP adaptive volume control	O		
X	7.5.3.3.1	Talker sidetone	M		
X	7.5.3.3.2	D Factor	M		
X	7.5.3.3.3	Sidetone delay	M		
X	7.5.3.4.1	TCLw of Portable Part	M		
	7.5.3.4.2	Stability loss	M		
X	7.5.3.5	Distortion	M		
	7.5.3.6	Out of band signals	M		
X	7.5.3.7	Noise	M		
	7.5.3.8	Acoustic shock	M		
	7.5.3.9	Delay:	M		
	7.5.3.10	Variation of gain with input level-sending	M		
X	7.5.3.11	Double Talk Performance	O		Strongly recommended for improved class
X	7.5.3.12	Switching characteristics	O		Strongly recommended for improved class
X	7.5.3.13	Quality of echo cancellation	O		Strongly recommended for improved class
PP types 3a and 3b: narrowband loudspeaking and hand free device					
X	7.2.7.3/7.2.8.3	General specification	M	X	
X	7.5.4.1	Sending sensitivity/frequency response	M	X	
X	7.5.4.2	Receive sensitivity/frequency response	M	X	
X	7.5.4.3	Sending loudness rating	M		
X	7.5.4.4	Receive loudness rating	M	X	
X	7.5.4.5	Sending distortion	M		
X	7.5.4.6	Receiving distortion	M		
X	7.5.4.7	Out-of-band signals in sending direction	M		
X	7.5.4.8	Out-of-band signals in receiving direction	M		
X	7.5.4.9	Sending noise	M		
X	7.5.4.10	Receiving noise	M		
X	7.5.4.11	Terminal Coupling Loss of PP	M	X	
X	7.5.4.12	Stability Loss of PP	M		
X	7.5.4.13	Double Talk Performance			
X	7.5.4.13.1	Attenuation Range in Sending Direction during Double Talk $A_{H,S,dt}$	M	X	
X	7.5.4.13.2	Attenuation Range in Receiving Direction during Double Talk $A_{H,S,dt}$	M	X	
X	7.5.4.13.3	Detection of Echo Components during Double Talk	O		
X	7.5.4.13.4	Minimum activation level and sensitivity of double talk detection	O		
X	7.5.4.14	Switching characteristics			
X	7.5.4.14.1	Activation in Sending Direction	M		
X	7.5.4.14.2	Activation in Receiving Direction	M		
X	7.5.4.14.3	Silence Suppression and Comfort Noise Generation	O		
X	7.5.4.14.4	Performance in sending direction in the presence of background noise	O		

CH	Clause Number	Requirement	M/O	S/I	Comments
Portable Part					
X	7.5.4.14.5	Speech Quality in the Presence of Background Noise	O		
X	7.5.4.14.6	Quality of Background Noise Transmission (with Far End Speech)	O		
X	7.5.4.14.7	Quality of background noise transmission (with Near End Speech)	O		
X	7.5.4.15	Quality of echo cancellation			
X	7.5.4.15.1	Temporal echo effects	O		
X	7.5.4.15.2	Spectral Echo Attenuation	O		
PP type 2a: ITU-T P.311 [20] tested wideband handset					
	7.2.9.3	General specification	M		
	7.5.5.1.1	Sending loudness rating	M		
	7.5.5.1.2	Sending sensitivity/frequency characteristics	M		
	7.5.5.1.3	Sending noise	M		
	7.5.5.1.4	Sending distortion	M		
	7.5.5.1.5	Discrimination against out-of-band input signals	M		
	7.5.5.2.1	Receiving loudness rating	M		
	7.5.5.2.2	Receiving sensitivity/frequency characteristics	M		
	7.5.5.2.3	Receiving noise	M		
	7.5.5.2.4	Receiving distortion	M		
	7.5.5.2.5	Spurious out-of-band receiving signals	M		
	7.5.5.3.1	Talker sidetone	M		
X	7.5.5.3.2	Sidetone distortion	M		
	7.5.5.4.1	Weighted terminal coupling loss	M		
	7.5.5.4.2	Stability loss	M		
PP types 2b and 2c: wideband handset					
X	7.5.10.3/ 7.5.11.3	General specification	M	X	
X	7.5.6.1	PP frequency responses	M	X	
X	7.5.6.2.1	PP sending and receiving loudness ratings: nominal values	M		
X	7.5.6.2.2	User controlled volume control in PP	M		
X	7.5.6.2.3	PP adaptive volume control	O		
X	7.5.6.3.1	Talker sidetone	M		
X	7.5.6.3.2	D Factor	M		
X	7.5.6.3.3	Sidetone delay	M		
X	7.5.6.4.1	Weighted Terminal Coupling Loss (TCLw):PP	M		
X	7.5.6.4.2	Stability loss	M		
X	7.5.6.5	Distortion	M		
X	7.5.6.6	Noise	M		
X	7.5.6.7	Acoustic shock	M		
X	7.5.6.8	Delay: PP	M		
X	7.5.6.9	Variation of gain with input level-sending	M		
X	7.5.6.10	Double Talk Performance	O		Strongly recommended for improved class
X	7.5.6.11	Switching characteristics	O		Strongly recommended for improved class
X	7.5.6.12	Quality of echo cancellation	O		Strongly recommended for improved class

CH	Clause Number	Requirement	M/O	S/I	Comments
Portable Part					
PP type 4a and 4b: wideband loudspeaking and handsfree device					
X	7.2.12.3/ 7.2.13.3	General specification	M	X	
X	7.5.7.1	Sending sensitivity/frequency response	M		
X	7.5.7.2	Receive sensitivity/frequency response	M	X	
X	7.5.7.3	Sending loudness rating	M		
X	7.5.7.4	Receive loudness rating	M	X	
X	7.5.7.5	Sending distortion	M		
X	7.5.7.6	Receiving distortion	M		
X	7.5.7.7	Out-of-band signals in sending direction	M		
X	7.5.7.8	Out-of-band signals in receiving direction	M		
X	7.5.7.9	Sending noise	M		
X	7.5.7.10	Receiving noise	M		
X	7.5.7.11	Terminal Coupling Loss of PP	M	X	
X	7.5.7.12	Stability Loss of PP	M		
X	7.5.7.13	Double Talk Performance			
X	7.5.7.13.1	Attenuation Range in Sending Direction during Double Talk $A_{H,S,dt}$	M	X	
X	7.5.7.13.2	Attenuation Range in Receiving Direction during Double Talk $A_{H,S,dt}$	M	X	
X	7.5.7.13.3	Detection of Echo Components during Double Talk	O	X	
X	7.5.7.13.4	Minimum activation level and sensitivity of double talk detection	O		
X	7.5.7.13.5	Minimum activation level and sensitivity of double talk detection	O		
X	7.5.7.14	Switching characteristics			
X	7.5.7.14.1	Activation in Sending Direction	M		
X	7.5.7.14.2	Activation in Receiving Direction	M		
X	7.5.7.14.3	Silence Suppression and Comfort Noise Generation	O		
X	7.5.7.14.4	Performance in sending direction in the presence of background noise	O		
X	7.5.7.14.5	Speech Quality in the Presence of Background Noise	O		
X	7.5.7.14.6	Quality of Background Noise Transmission (with Far End Speech)	O		
X	7.5.7.14.7	Quality of background noise transmission (with Near End Speech)	O		
X	7.5.7.15	Quality of echo cancellation			
X	7.5.7.15.1	Temporal echo effects	O		
X	7.5.7.15.2	Spectral Echo Attenuation	O		
PP type 5a: super-wideband 14 kHz handset					
X	7.2.14.3	General specification	M		Guidelines only. This type is for further study
PP type 5b: super-wideband 14 kHz handsfree device					
X	7.2.15.3	General specification	M		Guidelines only. This type is for further study
PP type 6: PPs with external 2 wire, 3,1 kHz telephony interface					
	Annex B	2-wire PP end system (informative)	M		Detailed specification informative only

Table 7.3: Detailed requirements included within each audio type (FPs)

C H	Clause Number	Requirement	M/O	S/I	Comments (see also table in clause E.1)
Fixed Part					
FP type 1a: "classic" Fixed Part with ISDN interface, narrowband service					
	7.3.2.3.1	Transcoding and equalization	M		
	7.3.2.3.2	PP type detection	M		
	7.3.2.3.4	Activation of audio processing functions	M		
	7.6.1.1	Reduction of echo from PP	M		
	7.6.1.2	FP Network echo control	O		
	7.6.1.3	FP adaptive volume control	O		
	7.6.1.4	FP Delay	M		
FP type 1b: "new" Fixed Part with ISDN interface, narrowband service					
	7.3.3.3.1	Transcoding and equalization	M		
X	7.3.3.3.2	PP type detection	O		
X	7.3.3.3.3	Activation of audio processing functions	O		
	7.6.2.1	FP Network echo control	O		
X	7.4.2	Echo canceller for PP	O		
X	7.4.3	Echo suppressor for PP	O		
	7.6.2.2	FP adaptive volume control	O		
X	7.6.2.3	FP Delay	M		
FP type 2: Fixed Part with analog PSTN interface, narrowband service					
	7.3.4.3.1	Transcoding, equalization and conversion	M		
	7.6.3.1	FP adaptive volume control	O		
	7.6.3.2	Network echo control	M		
	7.6.3.3	Additional requirements for DECT FP provided with a 2-wire PSTN interface	M		
	7.6.3.4.	FP Delay	M		
FP type 3: Fixed Part with VoIP interface, narrowband service					
X	7.3.5.3.1	Transcoding and equalization	M		
X	7.3.5.3.2	PP type detection	O		
X	7.3.5.3.3	Activation of audio processing functions	O		
X	7.6.4.3	Adaptive volume control	O		
X	7.4.2	Echo canceller for PP	O		
X	7.4.3	Echo suppressor for PP	O		
X	7.6.4.1	Send delay	M		
X	7.6.4.2	Receive delay	M		
FP type 4: Fixed Part with ISDN interface, wideband service					
X	7.3.6.3.1	Transcoding and equalization	M		
X	7.3.6.3.2	PP type detection	O		
X	7.3.6.3.3	Activation of audio processing functions			
X	7.4.2	Echo canceller for PP	O		
X	7.4.3	Echo suppressor for PP	O		
X	7.6.5.1	FP adaptive volume control	O		
X	7.6.2.2	FP Delay	M		
FP type 5: Fixed Part with VoIP interface, wideband service					
X	7.3.7.3.1	Transcoding and equalization	M		
X	7.3.7.3.2	PP type detection	O		
X	7.3.7.3.3	Activation of audio processing functions	O		
X	7.6.6.3	FP adaptive volume control	O		
X	7.4.2	Echo canceller for PP	O		
X	7.4.3	Echo suppressor for PP	O		
X	7.6.6.1	Send delay	M		
X	7.6.6.2	Receive delay	M		

C H	Clause Number	Requirement	M/O	S/I	Comments (see also table in clause E.1)
Fixed Part					
FP type 6a: Internal call inside a DECT FP (any service)					
X	7.3.8.3	Specification (transparent)	M		
FP type 6b: n-party conference inside a DECT FP (any service)					
X	7.3.9.3	Specification (informative)	M		
FP type 7: DECT Repeater part (REP)					
X	7.3.10.3	Specification (transparent)	M		

7.1.8 Audio Types and codecs

Audio types may be used with the different codecs listed as compatible in the definition of each type. As general rule, the audio specifications defined in the type should be fulfilled using all compatible codecs. This is true for the main requirements like the equalization mask or the echo cancellation (TCLw). However, some specific requirements may be influenced by the codec in use. An example is the delay.

When this happens, a table of parameters is provided with the difference values depending on the coded. When there is no specific mention the provided figure should be understood as applicable for codecs G.726 (Narrow-band) [12] and G.722 (Wide-band) [14].

7.1.9 Audio Types and physical interfaces

In the case of DECT FPs able to operate with different physical interfaces, the audio type is, in general, compatible with all of them. However some specific requirements may be influenced by the physical interface. A typical example is the delay in FPs with VoIP interfaces (depending on the interface and its data rate, the delay may change).

In this case, the detailed description of the requirement shall describe the interface for which the delay figure is correct.

7.2 Audio types applicable to Portable Parts

This clause specifies the Audio types applicable to DECT Portable Parts (PPs). All types except the type 0 (test) and type 6 (external i/f) include an acoustic air interface. There are three audio services: 3,1 kHz narrowband telephony, 7 kHz wideband telephony and 14 kHz super-wideband audio (this last one, for further study), and two specification methodologies: artificial ear, according to ITU-T Recommendation P.57 [26], used in types 1a, 1b and 2a and HATS according to ITU-T Recommendation P.58 [24], used in types 1c, 1d, 2b, 2c, 3a, 3b, 4a and 4b.

7.2.1 Performance levels of DECT Portable Parts (handsets)

ETSI standards for VoIP terminals (ES 202 737 [i.8], ES 202 738 [i.9], ES 202 739 [i.10], ES 202 740 [i.11]) have been written in order to specify equipment requirements which enable manufacturers and service providers to enable good quality end-to-end speech performance.

In some cases those requirements will be too severe for the market needs and cost target and more relaxed specifications would be necessary.

Considering this, specifications for several levels or target performance have been created. This will allow to cover a wide range of applications, markets and performance/cost targets:

For narrowband (3,1 kHz service):

- PP Type 1a: "Classic GAP" handset narrowband. This is the classic audio specification of the existing DECT GAP handsets (the only specification until revision V2.1.1 of the present document). It provides a satisfactory level of performance, similar to fixed lines, when connected to PSTN/ISDN networks.
- PP Type 1b: "Improved" GAP handset narrowband. This type adds a more demanding requirement of TCLw (better echo control) with the result of better satisfactory level of performance, even over VoIP or long delay networks.

- PP type 1c: "standard" narrowband HATS-tested DECT PP, with characteristics achievable by DECT devices at low/medium cost with performances tested with HATS methodology.
- PP type 1d: "improved" narrowband HATS-tested DECT PP, with better characteristics, closer to ES 202 737 [i.8] and ES 202 738 [i.9] standard requirements for VoIP terminals, corresponding to devices with enhanced capabilities, with performances tested with HATS methodology.

For wideband (7 kHz service):

- PP Type 2a: P.311-tested wideband handset introducing wideband with performances tested according ITU-T Recommendation P.311 [20].
- PP type 2b: "standard" wideband HATS-tested DECT PP with characteristics achievable by DECT devices at low/medium cost with performances tested with HATS methodology.
- PP type 2c: "improved" wideband HATS-tested DECT PP with better characteristics, closer to ES 202 739 [i.10] and ES 202 740 [i.11] standard requirements for VoIP terminals, corresponding to devices with enhanced capabilities, with performances tested with HATS methodology.

7.2.2 Type 0: Reference PP (RePP)

This type is only used for testing purposes. The functional model is described in figure 7.1.

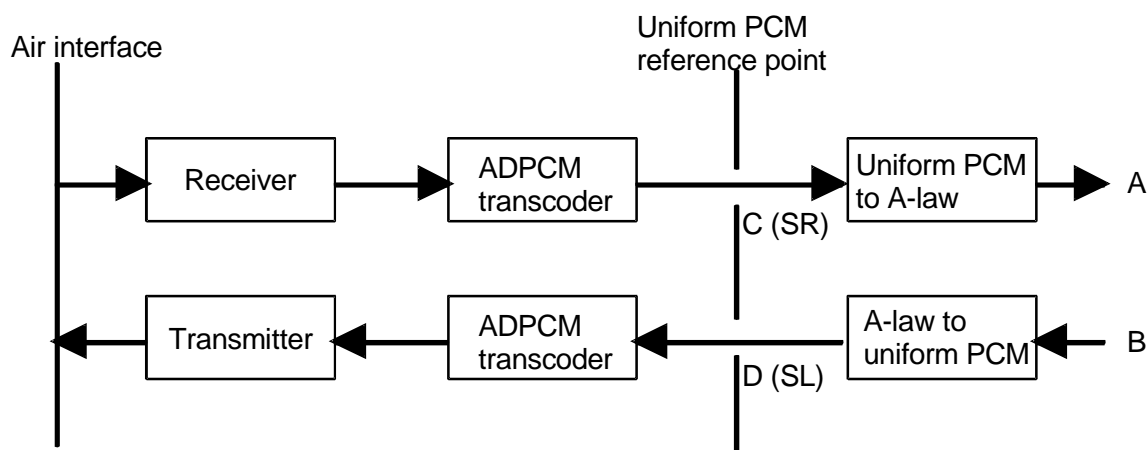

Figure 7.1: Reference PP (narrowband)

The RePP incorporates the specified transcoder algorithm as described in ITU-T Recommendation G.726 [12] at 32 kbit/s.

The Reference PP shall have the ability to loopback the ADPCM signal with a 5 ms delay.

NOTE: This 5 ms delay corresponds to the delay between the receive and transmit timeslots of a duplex bearer.

The reference PP shall have a value of TCLw of $36 \text{ dB} \pm 2 \text{ dB}$.

The uniform PCM reference points, points C and D in figure 7.1, are those designated SR and SL in ITU-T Recommendation G.726 [12] at 32 kbit/s.

7.2.3 PP Type 1a: "Classic" GAP narrowband handset

7.2.3.1 Introduction

The type 1a configuration is a general purpose 3,1 kHz telephony audio feature. This was the only type of narrowband DECT PP until the standard revision performed in 2008. It provides 3,1 kHz (300 Hz to 3,4 kHz) telephony service with a subjective quality comparable to fixed phones, when connected via PSTN/ISDN network.

Type 1a could produce echo issues in combination with VoIP or "long delay" networks. For this scenario, types 1b, 1c or 1d are recommended.

7.2.3.2 Compatible services and codecs

Type 1a provides telephony 3,1 kHz service and is compatible with codecs G.726 [12] and G.711 [13].

7.2.3.3 Specification

The PP shall fulfil the detailed audio specification for type 1a as described in clause 7.5.1. Transmission measurement shall be performed using artificial head. The artificial mouth shall conform to ITU-T Recommendation P.51 [28]. The artificial ear shall conform to ITU-T Recommendation P.57 [26].

The PP shall set the flags "echo parameters" in the IE <Terminal capability> (octet 3b) according to its TCLw capabilities (see EN 300 175-5 [5], clause 7.7.41). See table available in clause E.1.

7.2.4 PP Type 1b: "Improved" GAP narrowband handset

7.2.4.1 Introduction

The increasing use of internet and VoIP technologies in the networks forced a revision of the specification, increasing the value of the TCLw parameter in order to avoid echo issues when used over long delay networks.

Type 1b is identical to type 1a, except for an increased value of TCLw and parameters ensuring full duplex working which allows perfect operation even over long delay networks, like VoIP.

This applies to either:

- 1) DECT equipment connected to VoIP networks; or
- 2) VoIP technology used by network operators.

7.2.4.2 Compatible services and codecs

Type 1b provides telephony 3,1 kHz service and is compatible with codecs G.726 [12] and G.711 [13].

7.2.4.3 Specification

PP type 1b shall fulfil all requirements for type 1a described in clause 7.5.1 and the additional requirements as described in clause 7.5.2. Transmission measurements are performed using LRGP position of artificial head. The artificial mouth shall conform to ITU-T Recommendation P.51 [28]. The artificial ear shall conform to ITU-T Recommendation P.57 [26].

This PP type has always a TCLw value > 55 dB by type specification.

The PP shall set the flags "echo parameters" in the IE <Terminal capability> (bits 5 and 6 in octet 3b) always to "11", (TCLw > 55 dB, see EN 300 175-5 [5], clause 7.7.41).

7.2.5 PP Type 1c: HATS-tested "standard" narrowband handset

7.2.5.1 Introduction

Type 1c (HATS-tested "standard" narrowband) corresponds to narrowband handset developed with new methods of measurement using HATS instead of artificial head. This type of methodology is used for wideband equipment and is supposed to be more accurate than the classic model based on artificial head.

Type 1c provides an audio feature with improved acoustic parameters over type 1b. It includes strong echo suppression (TCLw) requirements and takes into account specificities of VoIP network.

This specification is also applicable to headsets.

7.2.5.2 Compatible services and codecs

Type 1c provides telephony 3,1 kHz service and is compatible with codecs G.726 [12] and G.711 [13].

7.2.5.3 Specification

The complete specification of PP type 1c is described in clause 7.5.3. PP type 1c shall fulfil all requirements described in clause 7.5.3 with the values given for "standard" quality devices.

This PP type has always a TCLw value > 55 dB by type specification.

The PP shall set the flags "echo parameters" in the IE <Terminal capability> (bits 5 and 6 in octet 3b) always to "11", (TCLw > 55 dB, see EN 300 175-5 [5], clause 7.7.41).

7.2.6 PP Type 1d: HATS-tested "improved" narrowband handset

7.2.6.1 Introduction

Type 1d (HATS-tested "improved" narrowband) corresponds to narrow band handset and headset developed with new methods of measurement using HATS instead of artificial head. This type of methodology is used for wideband equipment and is supposed to be more accurate than the classic model based on artificial head. HATS is becoming the new standard for audio test methodology.

The type 1d is a variation of type 1c with a more demanding acoustic specification, providing superior subjective quality. In practice, this means better electro-acoustic components (speaker, microphone), electronics and signal processing.

As Type 1c PP, Type 1d PP is intended to operate properly over VoIP networks.

This specification is also applicable to headsets.

7.2.6.2 Compatible services and codecs

Type 1d provides telephony 3,1 kHz service and is compatible with codecs G.726 [12] and G.711 [13].

7.2.6.3 Specification

The complete specification of PP type 1d is described in clause 7.5.3. PP type 1d shall fulfil all requirements described in clause 7.5.3 with the values given for "improved" quality devices.

This PP type has always a TCLw value > 55 dB by type specification.

The PP shall set the flags "echo parameters" in the IE <Terminal capability> (bits 5 and 6 in octet 3b) always to "11", (TCLw > 55 dB, see EN 300 175-5 [5], clause 7.7.41).

7.2.7 PP Type 3a: HATS tested narrowband "standard" loudspeaking handsfree

7.2.7.1 Introduction

The type 3a (HATS-tested "standard" narrowband handsfree) applies to narrowband handsfree and loudspeaking devices. This feature applies to either:

- 1) specific PPs designed to operate in handsfree mode;
- 2) standard handsets implementing audio types 1a, 1b, 1c or 1d, but with the option to operate in handsfree or loudspeaking mode; and
- 3) handsfree accessory devices connected to a handset by wired interfaces.

As the physical interface between handset and handsfree is not defined, the system has to be approved by manufacturer.

In case of headset or handsfree device connected by wireless interface, it is recommended that performances are in conformance with this specification.

Type 3a device provides narrowband 3,1 kHz telephony (300 Hz to 3,4 kHz) frequency range.

The type 3a loudspeaking and handsfree specifications is based on HATS methodology. It includes strong echo suppression requirements and is compatible with VoIP networks.

7.2.7.2 Compatible services and codecs

Type 3a provides telephony 3,1 kHz service and is compatible with codecs G.726 [12] and G.711 [13].

7.2.7.3 Specification

The complete specification of handsfree type 3a is described in clause 7.5.4. The values for "standard" quality devices shall be used.

There is a difference in specification parameters depending if the handsfree is a desktop or a handheld device.

7.2.8 PP Type 3b: HATS tested narrowband "improved" loudspeaking handsfree

7.2.8.1 Introduction

The type 3b (HATS-tested "improved" narrowband handsfree) is a variation of type 3a with a more demanding acoustic specification, providing superior subjective quality. In practice, this means better electro-acoustic components (speaker, microphone), electronics and signal processing.

As type 3a, type 3b is adapted to all networks including VoIP.

7.2.8.2 Compatible services and codecs

Type 3b provides telephony 3,1 kHz service and is compatible with codecs G.726 [12] and G.711 [13].

7.2.8.3 Specification

The complete specification of handsfree type 3b is described in clause 7.5.4. The values for "improved" quality devices shall be used.

There is a difference in specification parameters depending if the handsfree is a desktop or a handheld device.

7.2.9 PP Type 2a: P.311-tested wideband handset

7.2.9.1 Introduction

Type 2a introduces wideband handset function using ITU-T Recommendation P.311 [20] for requirements and testing.

7.2.9.2 Compatible services and codecs

Type 2a provides wideband telephony 7 kHz service and is compatible with codecs G.722 [14], G.729.1 [17] and MPEG-4 ER ACC-LD [18] operating at 32 kbit/s.

7.2.9.3 Specification

DECT type 2a PPs shall comply with all requirements of ITU-T Recommendation P.311 [20] as defined and with the exceptions given in clause 7.5.5.

PPs type 2a shall implement a TCLw value better than 42 dB.

NOTE: The requirement of TCLw defined in ITU-T Recommendation P.311 [20] is 35 dB.

The PP shall set the flag "echo parameters" in the IE <Terminal capability> (bits 5 and 6 in octet 3b) (see EN 300 175-5 [5], clause 7.7.4.1) according to its real TCLw value.

For PPs implementing narrowband and wideband modes, it is strongly recommended to implement similar values of TCLw for both modes. In case of differences, the bit setting shall be done as for the narrowband mode.

7.2.10 PP Type 2b: HATS-tested "standard" wideband handset or headset

7.2.10.1 Introduction

Type 2b (HATS-tested "standard" wideband) corresponds to wideband handset and headset developed with new methods of measurement using HATS instead of artificial head.

This specification provides more control, subjective quality and testability than the type 2a.

Type 2b includes strong echo suppression (TCLw) requirements and is specifically developed for operation over VoIP and long delay networks.

7.2.10.2 Compatible services and codecs

Type 2b provides wideband telephony 7 kHz service and is compatible with codecs G.722 [14], G.729.1 [17] and MPEG-4 ER ACC-LD [18] operating at 32 kbit/s.

7.2.10.3 Specification

The complete specification of PP type 2b is described in clause 7.5.6. The values for "standard" quality devices shall be used.

This PP type has always a TCLw value > 55 dB by type specification.

The PP shall set the flags "echo parameters" in the IE <Terminal capability> (bits 5 and 6 in octet 3b) always to "11", (TCLw > 55 dB, see EN 300 175-5 [5], clause 7.7.41).

For PPs implementing narrowband and wideband modes, it is strongly recommended to implement similar values of TCLw for both modes. In case of differences, the bit setting shall be done as for the narrowband mode.

7.2.11 PP Type 2c: HATS tested "improved" wideband handset or headset

7.2.11.1 Introduction

The type 2c (HATS-tested "improved" wideband) is a variation of type 2b with a more demanding acoustic specification, providing higher subjective quality. In practice, this means better electro-acoustic components (speaker, microphone), electronics and signal processing.

7.2.11.2 Compatible services and codecs

Type 2c provides wideband telephony 7 kHz service and is compatible with codecs G.722 [14], G.729.1 [17] and MPEG-4 ER ACC-LD [18] operating at 32 kbit/s.

7.2.11.3 Specification

The complete specification of PP type 2c is described in clause 7.5.6. The values for "improved" quality devices shall be used.

This PP type has always a TCLw value > 55 dB by type specification.

The PP shall set the flags "echo parameters" in the IE <Terminal capability> (bits 5 and 6 in octet 3b) always to "11", (TCLw > 55 dB, see EN 300 175-5 [5], clause 7.7.41).

For PPs implementing narrowband and wideband modes, it is strongly recommended to implement similar values of TCLw for both modes. In case of differences, the bit setting shall be done as for the narrowband mode.

7.2.12 PP Type 4a: HATS tested wideband "standard" loudspeaking handsfree

7.2.12.1 Introduction

The type 4a (HATS-tested "standard" wideband handsfree) applies to wideband handsfree and loudspeaking devices. The feature applies to either:

- 1) specific PPs designed to operate in handsfree mode;
- 2) standard handset implementing types 1 or 2, but with the option to operate in handsfree or loudspeaking mode; and
- 3) handsfree accessory devices connected to a handset by wired interfaces.

As the physical interface between handset and handsfree is not defined, the system has to be approved by manufacturer.

In case of headset or handsfree device connected by wireless interface, it is recommended that performances be in conformance with the present document.

Type 4a device provides wideband 7 kHz (150 Hz to 7 kHz) frequency range.

The type 4a loudspeaking and handsfree specifications are based on HATS methodology. They include strong echo suppression requirements and are compatible with VoIP networks.

7.2.12.2 Compatible services and codecs

Type 4a provides wideband telephony 7 kHz service and is compatible with codecs G.722 [14], G.729.1 [17] and MPEG-4 ER ACC-LD [18] operating at 32 kbit/s.

7.2.12.3 Specification

The complete specification of handsfree type 4a is described in clause 7.5.7. The values for "standard" quality devices shall be used.

There is a difference in specification parameters depending if the handsfree is a desktop or a handheld device.

7.2.13 PP Type 4b: HATS tested wideband "improved" loudspeaking and handsfree

7.2.13.1 Introduction

The type 4b (HATS-tested "improved" wideband handsfree) is a variation of type 4a with a more demanding acoustic specification, providing superior subjective quality. In practice, this means better electro-acoustic components (speaker, microphone), electronics and signal processing.

As type 4a, the type 4b loudspeaking and handsfree specifications are based on HATS methodology. They include strong echo suppression requirements and are compatible with VoIP networks.

7.2.13.2 Compatible services and codecs

Type 4b provides wideband telephony 7 kHz service and is compatible with codecs G.722 [14], G.729.1 [17] and MPEG-4 ER ACC-LD [18], [19] operating at 32 kbit/s.

7.2.13.3 Specification

The complete specification of handsfree type 4b is described in clause 7.5.7. The values for "improved" quality devices shall be used.

There is a difference in specification parameters depending if the handsfree is a desktop or a handheld device.

7.2.14 PP Type 5a: super-wideband 14 kHz handset

7.2.14.1 Introduction

The type 5a is reserved for the specification of super-wideband handsets providing 14 kHz frequency range.

This type also applies to headset devices.

7.2.14.2 Compatible services and codecs

It is compatible with MPEG-4 ER ACC-LD [18], [19] operating at 64 kbit/s.

7.2.14.3 Specification

The specification of type 5a, super-wideband handset is for further study.

As guideline, it is recommended to fulfil at least the specification for type 2c, wideband 7 kHz handset.

7.2.15 PP Type 5b: super-wideband 14 kHz loudspeaking handsfree

7.2.15.1 Introduction

The type 5b is reserved for the specification of super-wideband handsfree providing 14 kHz frequency range.

7.2.15.2 Compatible services and codecs

It is compatible with MPEG-4 ER ACC-LD [18], [19] operating at 64 kbit/s.

7.2.15.3 Specification

The specification of type 5b, super-wideband handsfree is for further study.

As guideline, it is recommended to fulfil at least the specification for type 4a, wideband 7 kHz handsfree.

7.2.16 PP Type 6: PPs with external 2 wire, 3,1 kHz telephony interface

7.2.16.1 Introduction

The type 6 applies to PP with external 2 wire 3,1 kHz telephony interfaces, in order to connect a traditional phone. Such devices are used in Wireless local Loop systems.

See annex B.

7.2.16.2 Compatible services and codecs

Type 6 provides telephony 3,1 kHz service and is compatible with codecs G.726 [12] and G.711 [13].

7.2.16.3 Specification

The detailed specification for PPs type 6 is described in annex B.

7.3 Audio transmission types applicable to Fixed Parts

This clause specifies the Audio Transmission Types applicable to DECT Fixed Parts (FPs). All FP types are electrical specifications and do not include any acoustic interface. In many cases, the feature is a transparent audio transmission with or without transcoding. In other cases, analog interfaces or signal processing are included.

When possible, a single feature may be used with multiple codecs and frequency ranges. In other cases, the specification applies only to one telephony service.

DECT FPs handling internal calls between DECT devices or multipart conferences, as well as DECT repeaters (REP) have dedicated audio types for these cases.

The reference interfaces for the FP audio types described in this clause are:

- The DECT air interface.
- The FP or system interface to the external public or private network.

In residential systems (stand-alone FPs with external interface to a public network) "FP" in this clause means the DECT residential FP device with its external interface.

In business systems (PABX with DECT terminals), "FP" in this clause means the complete path between the DECT air interface and the external interface of the PABX system towards the public or private network. The Audio type specifies the audio model between these two reference points.

NOTE: In business systems, the internal interface between base stations and the PABX is in most cases an intra-system proprietary interface.

In the case of FPs with VoIP interfaces (FP types 3 and 5), there is a potential large number of physical interfaces at the network port (IEEE 802.11 [i.23], ADSL, WIFI, USB, etc.). An informative table lists the most usual cases. Most detailed requirements are independent on the physical interface, however some of them (mainly the delay) depend or are influenced by this interface. When this happens, it is noted in the detailed specification text.

7.3.1 FP Type 0: Reference FP (ReFP)

A ReFP is shown in figure 7.2 and they incorporate the specified transcoder algorithm as described in ITU-T Recommendation G.726 [12] at 32 kbit/s.

The Reference FP shall have the ability to loopback the ADPCM signal with a 5 ms delay.

NOTE: This 5 ms delay corresponds to the delay between the receive and transmit timeslots of a duplex bearer.

The uniform PCM reference points, points C and D in figure 7.2, are those designated SR and SL in ITU-T Recommendation G.726 [12] at 32 kbit/s.

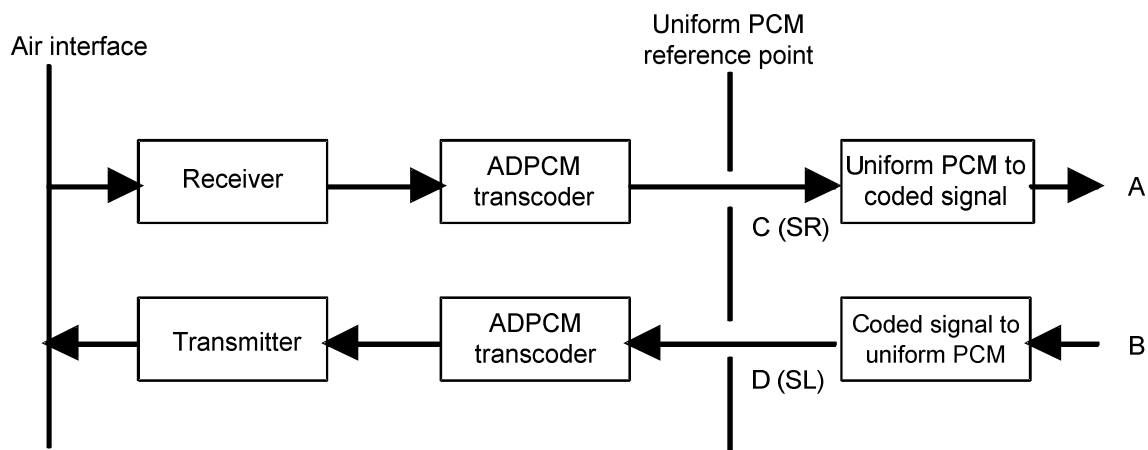

Figure 7.2: Reference FP

7.3.2 FP Type 1a: "classical" Fixed Part for ISDN Network

7.3.2.1 Introduction

The FP type 1a is a FP with ISDN (or other digital circuit-switched) interface providing 3,1 kHz telephony service. This was the only type of DECT FP with ISDN interface until the standard revision performed in 2008. It provides 3,1 kHz (300 Hz to 3,4 kHz) telephony service with a subjective quality comparable to fixed phones, when connected via ISDN network.

7.3.2.2 Compatible services and codecs

Type 1a provides telephony 3,1 kHz service and is compatible with codecs G.726 [12] and G.711 [13] over air interface. Codec over line interface is usually G.711 [13] (ISDN interface). In some cases, it could also be G.726 [12].

7.3.2.3 Specifications

7.3.2.3.1 Transcoding and equalization

FP shall perform transparent transcoding to/from ADPCM G.726 [12] from/to PCM G.711 [13] A-law or μ -law.

- Exception 1: no transcoding is needed if the air interface is using G.711 [13] codec.
- Exception 2: in some systems (usually PABX systems) it is allowed to use G.726 codec over 32 kbit/s channels on the external i/f. In such a case, no transcoding is needed if air interface is G.726 and features from clauses 7.6.1.3 and 7.3.2.4 are not used.

FP shall be transparent regarding audio levels unless the features 7.6.1.3 or 7.3.2.4 are activated.

NOTE: There is no practical difference between A-law and μ -law.

7.3.2.3.1.1 Equipment Impairment value for end-to-end transmission planning

According to ITU-T Recommendation G.113 [i.13], the PCM to ADPCM to PCM transcoding incurs an Equipment Impairment Factor of I.e.=7 for ADPCM at 32 kbit/s.

For further information see ITU-T Recommendations G.107 [i.14], G.108 [i.15] and G.109 [i.16].

7.3.2.3.2 PP type detection

FP shall observe the value of the flag "TCLw > 46 dB" (bit 6) of "echo parameters" (octet 3b) in the IE <Terminal capability>, supplied by the PP at registration (see EN 300 175-5 [5], clause 7.7.41). According to the value of this flag, the PP may be of two types:

- PP with 34 dB < TCLw < 46 dB.
- PP with TCLw > 46 dB.

NOTE: FPs type 1a does not need to distinguish if the PP has TCLw > 55 dB, since the processing is the same as for PPs with TCLw > 46 dB.

7.3.2.3.3 Activation of audio processing functions

If the PP has TCLw < 46 dB, the FP shall activate the function of reduction of echo from PP described in clause 7.6.1.1 (either artificial echo loss or echo control device).

If the PP has TCLw > 46 dB, the FP may activate the function of reduction of echo from PP described in clause 7.6.1.1 (either artificial echo loss or echo control device).

In any case, the FP shall perform the transcoding described in clause 7.3.2.3.1 and may include the adaptive volume control described in clause 7.6.1.3.

NOTE: The implementation of the feature reduction of echo from PP (see clause 7.6.1.1) is mandatory in a type 1a FP.

The FP shall implement the function "echo suppression for echo coming from the network" and shall activate it as described in clause 7.6.1.2.

7.3.2.3.4 Transmission specification

The FP shall fulfil the transmission requirements described in the following clauses:

- 7.6.1.1 Reduction of echo from PP.
- 7.6.1.2 FP Network echo control.
- 7.6.1.4 FP delay.

The FP may implement the following feature:

- 7.6.1.3 Adaptive volume control.

If implemented, the FP shall fulfil the requirements described in the associated clause.

7.3.3 FP Type 1b: "new" Fixed Part for ISDN Network

7.3.3.1 Introduction

The increasing use of internet and VoIP technologies in the networks forced a revision of this specification. It was identified that echo control architecture in type 1a may decrease quality in some scenarios. Consequently, the FP type 1b "new ISDN (narrowband) FP" was created. The modification compared to type 1a consists of a new strategy of PP echo control. In most cases the FP will be transparent, and optional echo cancellation suppression features may be activated only if the PP is identified as type 1a or 2a.

7.3.3.2 Compatible services and codecs

Type 1b provides telephony 3,1 kHz service and is compatible with codecs G.726 [12] and G.711 [13] over air interface. Codec over line interface is usually G.711 [13] (ISDN interface). In some cases, it could also be G.726 [12].

7.3.3.3 Specification

7.3.3.3.1 Transcoding and equalization

FP shall perform transparent transcoding to/from ADPCM G.726 [12] from/to PCM G.711 [13] A-law or μ -law.

- Exception 1: no transcoding is needed if the air interface is using G.711 [13] codec.
- Exception 2: in some systems (usually PABX systems) it is allowed to use G.726 codec over 32 kbit/s channels on the external i/f. In such a case, no transcoding is needed if air interface is G.726 and features 7.6.2.2, 7.4.2 or 7.4.3 are not used.

FP shall be transparent regarding audio levels unless the features 7.6.2.2 or 7.4.3 are activated.

NOTE: There is no practical difference between A-law and μ -law.

7.3.3.3.1.1 Equipment Impairment value for end-to-end transmission planning

According to ITU-T Recommendation G.113 [i.13], the PCM to ADPCM to PCM transcoding incurs an Equipment Impairment Factor of $I.e.=7$ for ADPCM at 32 kbit/s.

For further information see ITU-T Recommendations G.107 [i.14], G.108 [i.15] and G.109 [i.16].

7.3.3.3.2 PP type detection

FP shall observe the value of the flags "echo parameters" in the octet 3b of the IE <Terminal capability>, supplied by the PP at registration (see EN 300 175-5 [5], clause 7.7.41). According to the value of the bit, the PP may be of three types:

- PP with $34 \text{ dB} < \text{TCLw} < 46 \text{ dB}$.
- PP with $\text{TCLw} > 46 \text{ dB}$ (Full TCLw).
- PP with $\text{TCLw} > 55 \text{ dB}$ (TCLw compatible with VoIP).

If the FP does not implement any echo optional suppression facility for echo coming from the PP, then it can skip the PP type detection.

7.3.3.3.3 Activation of audio processing functions

The PP may implement echo control facilities. There are two options:

- PP echo canceller (described in clause 7.4.2).
- PP echo suppressor (described in clause 7.4.3).

If the FP does implement any optional echo control facility for echo coming from the PP, then it shall perform the PP type detection and shall act as follows:

- If the PP has a $\text{TCLw} > 55 \text{ dB}$, THEN, The FP SHALL NOT activate any echo cancellation or suppression facility for echo coming from the PP (clause 7.4).
- If the PP has $46 \text{ dB} < \text{TCLw} < 55 \text{ dB}$, THEN the FP may activate the echo control facility only if it is of the type "echo cancellation" (see clause 7.4.2).
- If the PP has $34 \text{ dB} < \text{TCLw} < 46 \text{ dB}$, THEN, the FP SHALL activate the echo cancellation (clause 7.4.2) or suppression facility (clause 7.4.3).

In any case, the PP shall perform the transcoding described in clause 7.3.3.3.1 and may include the adaptive volume control described in clause 7.6.2.1.

NOTE: The FP should never introduce the feature "artificial echo loss" (described in clause 7.6.1.1) in any case.

7.3.3.3.4 Transmission specification

The FP shall fulfil the transmission requirements described in the following clauses:

- 7.6.2.1 FP Network echo control.
- 7.6.2.3 FP delay.

The FP may implement the following features:

- 7.6.2.2 Adaptive volume control.
- 7.4.2 PP Echo canceller.
- 7.4.3 PP echo suppressor.

If implemented, the FP shall fulfil the requirements described in the listed clauses.

7.3.4 FP Type 2: FP with analog 2-wire interface, 3,1 kHz service

7.3.4.1 Introduction

Type 2 configuration is a general purpose 3,1 kHz telephony audio feature for PSTN interface.

NOTE: The present document introduces no modification for this type of FP.

When connecting a "classic GAP" (1a) or "improved GAP" (1b) Portable Part to this type of FP, system will present for network characteristics of a corded terminal in conformance with TBR 038 [29] requirement.

7.3.4.2 Compatible services, physical interfaces and codecs

FP type 2 provides a telephony 2-wire analog interface with 300 Hz to 3 400 Hz bandwidth.

It is compatible with codecs G.726 [12] and G.711 [13] over air interface.

7.3.4.3 Specification

7.3.4.3.1 Transcoding, equalization and conversion

FP shall perform conversion to analog 2-wire telephone interface from ADPCM G.726 [12] or PCM G.711 [13] air interface codec signal.

The equalization over the analog line is described in the additional requirements given in clause 7.6.3.3.

7.3.4.3.1.1 Equipment Impairment value for end-to-end transmission planning

According to ITU-T Recommendation G.113 [i.13], the PCM to ADPCM to PCM transcoding incurs an Equipment Impairment Factor of I.e.=7 for ADPCM at 32 kbit/s.

The introduced D/A and A/D converters will incur small quantization errors, which often could be neglected for practical planning purposes. For further information see ITU-T Recommendations G.107 [i.14], G.108 [i.15] and G.109 [i.16].

According to ITU-T Recommendation G.113 [i.13], the PCM to ADPCM to PCM transcoding incurs an Equipment Impairment Factor of I.e.=7 for ADPCM at 32 kbit/s.

7.3.4.3.2 PP type detection and activation of audio processing functions

There is no need for PP type detection and activation of conditional audio processing functions.

7.3.4.3.3 Transmission specification

The FP shall fulfil the transmission requirements described in the following clauses:

- 7.6.3.2 Network echo control.
- 7.6.3.3 Additional requirements for DECT FP provided with a 2-wire PSTN interface.
- 7.6.3.4 FP delay.

The FP may implement the following feature:

- 7.6.3.1 Adaptive volume control.

If implemented, the FP shall fulfil the requirements described in the noted clause.

7.3.5 FP Type 3: VoIP narrowband Fixed Part

7.3.5.1 Introduction

The FP type 3 applies to DECT FP with a packet-data interface based on Internet Protocol and supporting the 3,1 kHz service.

7.3.5.2 Compatible services, physical interfaces and codecs

Type 3 provides telephony 3,1 kHz service and is compatible with codecs G.726 [12] and G.711 [13] over air interface.

Physical interfaces shall be any digital interface supporting an IP stack of VoIP (voice over IP).

Codec over VoIP interface is usually G.711 [13]. G.726 [12] is also allowed.

An example of protocol stack is RTP [i.3] over UDP [i.2] over IP [i.1]. Other stacks may be allowed (i.e. with TCP). Any transport below IP is allowed.

Typical physical interfaces are:

- IEEE 802.3 [i.24].
- ADSL/VDSL over a phone line.
- Wifi or WiMAX radio i/f.
- USB.

There are several possible stacks on top of these physical interfaces. This specification applies to all of them. Examples of widely used stacks are the following.

Table 7.4: Examples of stacks for VoIP narrowband interface

Example 1	Example 2	Example 3
Voice G.711	Voice G.711	Voice G.711
RTP	RTP	RTP
UDP	UDP	UDP
IP	IP	IP
IEEE 802.3 [i.24]	IEEE 802.3 [i.24]	ATM AAL5
	ATM AAL5	ADSL
	ADSL	

The case of Packet Voice transported directly over ATM/ADSL (AAL1 or AAL2) is also supported by this audio type.

7.3.5.3 Specification

7.3.5.3.1 Transcoding and equalization

FP shall perform transparent transcoding to/from ADPCM G.726 [12] from/to PCM G.711 [13] A-law or μ -law.

- Exception 1: no transcoding is needed if the air interface is using G.711 [13] codec.
- Exception 2: in some cases, codec G.726 is used on the external i/f. In such a case, no transcoding is needed if air interface is G.726 and features 7.6.4.3, 7.4.2 or 7.4.3 are not used.

FP shall be transparent regarding audio levels unless the features 7.6.4.3 or 7.4.3 are activated.

NOTE: There is no practical difference between A-law and μ -law.

7.3.5.3.1.1 Equipment Impairment value for end-to-end transmission planning

According to ITU-T Recommendation G.113 [i.13], the PCM to ADPCM to PCM transcoding incurs an Equipment Impairment Factor of I.e.=7 for ADPCM at 32 kbit/s.

For further information see ITU-T Recommendations G.107 [i.14], G.108 [i.15] and G.109 [i.16].

7.3.5.3.2 PP type detection

FP shall observe the value of the flags "echo parameters" in the octet 3b of the IE <Terminal capability>, supplied by the PP at registration (see EN 300 175-5 [5], clause 7.7.41). According to the value of the bit, the PP may be of three types:

- PP with $34 \text{ dB} < \text{TCLw} < 46 \text{ dB}$.
- PP with $\text{TCLw} > 46 \text{ dB}$ (Full TCLw).
- PP with $\text{TCLw} > 55 \text{ dB}$ (TCLw compatible with VoIP).

If the FP does not implement any echo optional suppression facility for echo coming from the PP, then it can skip the PP type detection.

7.3.5.3.3 Activation of audio processing functions

The PP may implement echo control facilities. There are two options:

- PP echo canceller (described in clause 7.4.2).
- PP echo suppressor (described in clause 7.4.3).

If the FP does implement any optional echo control facility for echo coming from the PP, then it shall perform the PP type detection and shall act as follows:

- If the PP has a $\text{TCLw} > 55 \text{ dB}$, THEN, The FP SHALL NOT activate any echo cancellation or suppression facility for echo coming from the PP (clause 7.4).
- If the PP has $46 \text{ dB} < \text{TCLw} < 55 \text{ dB}$, THEN the FP may activate the echo control facility only if it is of the type "echo cancellation" (see clause 7.4.2).
- If the PP has $34 \text{ dB} < \text{TCLw} < 46 \text{ dB}$, THEN, the FP SHALL activate the echo cancellation (clause 7.4.2) or suppression facility (clause 7.4.3).

In any case, the PP shall perform the transcoding described in clause 7.3.5.3.1 and may include the adaptive volume control described in clause 7.6.4.3.

NOTE: The FP should never introduce the feature "artificial echo loss" (described in clause 7.6.1.1) in any case.

7.3.5.3.4 Transmission specification

The FP shall fulfil the transmission requirements described in the following clauses:

- 7.6.4.1 Send delay.
- 7.6.4.2 Receive delay.

The FP may implement the following feature:

- 7.6.4.3 Adaptive volume control.
- 7.4.2 PP Echo canceller.
- 7.4.3 PP echo suppressor.

If implemented, the FP shall fulfil the requirements described in the listed clauses.

7.3.6 FP Type 4: ISDN wideband Fixed Part

7.3.6.1 Introduction

Type 4 is a Fixed part providing wideband (7 kHz) or super-wideband (14 kHz) services with a 64 kbit/s circuit switched network interface, usually ISDN.

7.3.6.2 Compatible services and codecs

G.722 [14], G.729.1 [17] and MPEG-4 ER AAC-LD [18], [19] compatible with FP type 4.

The provided service depends on the codec type.

Physical interfaces may be any circuit mode digital interface over 64 kbit/s channels including:

- ISDN BRA (U or S/T physical i/f);
- ISDN PRA over E1 or T1 links (used by PABX systems).

Any other digital interface toward the public telephone network.

NOTE: If ISDN is used, the wideband audio signal is transported as "digital unrestricted" over the ISDN bearer.

7.3.6.3 Specification

7.3.6.3.1 Transcoding and equalization

In general, no transcoding is used in wideband FPs. Air interface codec is equal to line interface codec. However, the transcoding to other line codec supporting wideband is, in theory, possible.

In all cases, FP shall be transparent regarding audio levels.

7.3.6.3.2 PP type detection

This clause is applicable only if the FP implements any optional PP echo control function.

FP shall observe the value of the flags "echo parameters" in the octet 3b of the IE <Terminal capability>, supplied by the PP at registration (see EN 300 175-5 [5], clause 7.7.41). According to the value of the bit, the PP may be of three types:

- PP with 42 dB (see note) < TCLw < 46 dB.

- PP with $TCLw > 46$ dB (Full $TCLw$).
- PP with $TCLw > 55$ dB ($TCLw$ compatible with VoIP).

NOTE: In wideband mode, cases 1 and 2 may only happen with PPs type 2a, and $TCLw$ should be always > 42 dB.

If the FP does not implement any echo optional suppression facility for echo coming from the PP, then it can skip the PP type detection.

7.3.6.3.3 Activation of audio processing functions

If the FP does not implement any echo optional suppression facility for echo coming from the PP, then it can skip the operations described in this clause.

If the FP does implement any echo optional suppression facility for echo coming from the PP, then it shall perform the PP type detection and shall act as follows:

- If the PP has a $TCLw > 55$ dB, THEN, The FP SHALL NOT activate any echo cancellation or suppression facility for echo coming from the PP (clause 7.4.2 or 7.4.3).
- If the PP has $46 \text{ dB} < TCLw < 55$ dB, THEN the FP MAY activate the echo cancellation facility only if it is of the type "echo cancellation" (see clause 7.4.2).
- If the PP has $TCLw 42 \text{ dB} < TCLw < 46$ dB, THEN, the FP SHALL activate the echo cancellation (clause 7.4.2) or suppression facility (clause 7.4.3).

7.3.6.3.4 Transmission specification

The FP shall fulfil the transmission requirements described in the following clauses:

- 7.6.5.2 FP delay.

The FP may implement the following features:

- 7.6.5.1 Adaptive volume control.
- 7.4.2 PP Echo canceller.
- 7.4.3 PP echo suppressor.

If implemented, the FP shall fulfil the requirements described in the listed clauses.

7.3.7 FP Type 5: VoIP wideband Fixed Part

7.3.7.1 Introduction

The FP type 5 applies to DECT FP with a packet-data interface based on Internet Protocol and supporting the 7 kHz (wideband) or 14 kHz (super-wideband) services.

The FP type 5 is identical to type 3, but with any wideband codec on top of the VoIP interface.

7.3.7.2 Compatible services, physical interfaces and codecs

G.722 [14], G.729.1 [17] and MPEG-4 ER AAC-LD [19], [18] are compatible with FP type 5.

The provided service depends on the codec type.

Physical interfaces shall be any digital interface supporting an IP stack of VoIP (voice over IP).

An example of protocol stack is RTP [i.3] over UDP [i.2] over IP [i.1]. Other stacks may be allowed (i.e. with TCP). Any transport below IP is allowed.

Typical physical interfaces are:

- IEEE 802.3 [i.24].
- ADSL/VDSL over a phone line.
- Wifi or WiMAX radio i/f.
- USB.

There are several possible stacks on top of these physical interfaces. This specification applies to all of them. Examples of widely used stacks are the following.

Table 7.5: Examples of stacks for VoIP wideband interface

Example 1	Example 2	Example 3
Voice G.722, G.729.1 or MPEG	Voice G.722, G.729.1 or MPEG	Voice G.722, G.729.1 or MPEG
RTP	RTP	RTP
UDP	UDP	UDP
IP	IP	IP
IEEE 802.3 [i.24]	IEEE 802.3 [i.24]	ATM AAL5
	ATM AAL5	ADSL
	ADSL	

7.3.7.3 Specification

7.3.7.3.1 Transcoding and equalization

In general, no transcoding is used in wideband FPs. Air interface codec is equal to line interface codec. However, the transcoding to other line codec supporting wideband is, in theory, possible.

In all cases, FP shall be transparent regarding audio levels.

7.3.7.3.2 PP type detection

This clause is applicable only if the FP implements any optional PP echo control function.

FP shall observe the value of the flags "echo parameters" in the octet 3b of the IE <Terminal capability>, supplied by the PP at registration (see EN 300 175-5 [5], clause 7.7.41). According to the value of the bit, the PP may be of three types:

- PP with 42 dB (see note) < TCLw < 46 dB.
- PP with TCLw > 46 dB (Full TCLw).
- PP with TCLw > 55 dB (TCLw compatible with VoIP).

NOTE: In wideband mode, cases 1 and 2 may only happen with PPs type 2a, and TCLw should be always > 42 dB.

If the FP does not implement any echo optional suppression facility for echo coming from the PP, then it can skip the PP type detection.

7.3.7.3.3 Activation of audio processing functions

If the FP does not implement any echo optional suppression facility for echo coming from the PP, then it can skip the operations described in this clause.

If the FP does implement any echo optional suppression facility for echo coming from the PP, then it shall perform the PP type detection and shall act as follows:

- If the PP has a TCLw > 55 dB, THEN, The FP SHALL NOT activate any echo cancellation or suppression facility for echo coming from the PP (clause 7.4.2 or 7.4.3).

- If the PP has $46 \text{ dB} < \text{TCLw} < 55 \text{ dB}$, THEN the FP MAY activate the echo cancellation facility only if it is of the type "echo cancellation" (see clause 7.4.2).
- If the PP has $\text{TCLw} 42 \text{ dB} < \text{TCLw} < 46 \text{ dB}$, THEN, the FP SHALL activate the echo cancellation or suppression facility. (clause 7.4.2).

7.3.7.3.4 Transmission specification

The FP shall fulfil the transmission requirements described in the following clauses:

- 7.6.6.1 Send delay.
- 7.6.6.2 Receive delay.

The FP may implement the following features:

- 7.6.6.3 Adaptive volume control.
- 7.4.2 PP Echo canceller.
- 7.4.3 PP echo suppressor.

If implemented, the FP shall fulfil the requirements described in the listed clauses.

7.3.8 FP Type 6a: FP handling an Internal call inside a DECT FP (any service)

7.3.8.1 Introduction

The type 6a applies to the case of internal call inside a DECT FP or a DECT system without any external interface.

This type applies to any service.

7.3.8.2 Compatible services, physical interfaces and codecs

Any air interface codec can be used with this FP type.

The same codec should be used by the two peers involved in the internal call.

There is no external interface, by definition.

7.3.8.3 Specification

Type 6a FP shall perform a transparent translation between both air interfaces without any signal processing or equalization.

7.3.9 FP Type 6b: FP handling an n-party conference inside a DECT FP (any service)

7.3.9.1 Introduction

The type 6b applies to the case of 3 or multi-party conference inside a DECT FP or a DECT system with or without an external interface.

This type applies to any service.

7.3.9.2 Compatible services, physical interfaces and codecs

Any air interface codec can be used with this RFP feature.

The same codec should be used by all DECT PPs involved in the internal call.

The reference model between two DECT PPs connected in conference shall be as described in clause 7.3.9.3.

If the conference involves one or more users connected via the network interface, then the reference model for this branch shall also include the functions described for the FP audio type according to service and the network interface.

NOTE: This means for instance: that in 3,1 kHz service, the echo suppression functions from network side and PP side (if implemented and active) described in the FP type should be active in the branch to the external user(s).

7.3.9.3 Specification for the conference bridge

This specification is for further study.

The guideline is performing a linear addition of the signals with the option to perform any level compensation reducing the level of the signal from no reduction to 3 dB reduction per party. The volume control for the parties connected via the external interface is free to the implementer.

7.3.10 FP Type 7: DECT Repeater part (REP)

7.3.10.1 Introduction

This type applies to the DECT Repeater Part (REP) if used in a DECT system.

7.3.10.2 Compatible services, physical interfaces and codecs

Any air interface codec can be used with this feature.

7.3.10.3 Specification

The DECT Repeater (REP) shall be transparent on regard to the audio signal.

7.4 Additional features

7.4.1 Introduction

The "classic" DECT was designed based on the traditional PSTN infrastructure working in environments with well controlled transmission delays and TCL requirements:

- When using a DECT system in analog connections the echo loss provided by the DECT system is mainly determined by the hybrid echo. Echo cancellation was needed only in connections to the mobile networks or in international calls. In both cases echo cancellers either installed in the mobile network or in international switching centers took care of the hybrid echo as well as of the additional (acoustic) echo produced by the portable part.
- When using the DECT system in digital connections two approaches were taken: either inserting an artificial echo loss or providing a PP with $TCL_w > 46$ dB. When inserting the artificial echo loss the network echo cancellers took care of any echo cancellation needed (as for analog terminals), when providing $TCL_w > 46$ dB there was no or only a low risk of echo for mostly all of the connections.

When moving to VoIP networks, the transmission delays are higher, time variant and unpredictable. No echo cancellation is provided by the network. Any terminal or gateway connected to the IP-network has to provide sufficient echo loss even for the worst case situation (high transmission delay). The same applies to any DECT system connected to VoIP networks or other digital networks. Therefore any DECT PP connected to a New Generation Network would have to provide an echo loss of at least 55 dB which cannot be achieved with classic GAP PPs. As a consequence echo control has to be provided by those FPs which allow the connection of classic GAP PPs. When providing this solution the following points have to be considered:

- For classic GAP DECT PPs (type 1a), additional echo loss is required since in the worst case the echo loss provided by a classic DECT PP is 34 dB. The only way to provide additional echo loss is to implement additional echo loss in the NG-DECT FP. It is required to provide at least 21 dB echo loss in addition to the echo loss provided by the classic DECT PP. Care has to be taken when implementing additional echo loss in the FP. Either echo suppression or echo cancellation can be used. Echo cancellation is the preferred solution since in principle it provides a better speech quality. The following points have to be considered when providing high quality echo cancellation in the FP:
 - Non linear echo path due e.g. to ADPCM Coding and other signal processing in the PP.
 - Low but (depending on delay) annoying echo signals from the classic DECT PP.
 - No additional switching should be detectable.
 - Echo loss during double talk needs to be maintained.
 - Sufficient echo loss needs to be provided in background noise situations.
- PP type 2a (wideband handset, P.311 based specification), may also have $TCLw < 55$ dB and may also require echo reduction at the FP. However, only 13 dB are required in the worst case, since PPs type 2a always have a $TCLw > 42$ dB by type definition (see clauses 7.2.9.3 and 7.5.5).

7.4.2 Echo canceller in Fixed Part

In the context of this specification, the term "echo canceller" means an echo reduction feature based on signal processing and placed in the 4-wire portion of the circuit, that works by estimating and echo signal and subtracting such estimation (with the proper phase), from the signal coming from the end which echo is to be cancelled (see [i.20] and [i.21]).

In the context of this clause, the echo is produced by the PP and comes from the air interface. In case of connection with PP type 1a ("classic" GAP) an echo canceller may be used with constraints as described in clause 7.4.1. The required level of echo cancellation depends on the PP $TCLw$ value, that is transmitted to the FP at registration by means of the flags "echo parameters" in the octet 3b of the IE <Terminal capability>. For low $TCLw$ PPs (not "Full $TCLw$ ") echo cancellation has to be more than 21 dB. For a "Full $TCLw$ " PP an echo cancellation of 9 dB is sufficient. The feature should be disabled if the PP indicates "VoIP compatible" PP ($TCLw > 55$ dB).

The feature is also applicable to PP type 2a (wideband handset, P.311 based specification). In such a case the echo canceller should be able to operate over the wideband frequency range.

NOTE: The only PP types that may require this echo cancellation feature are the types 1a and 2a. The feature should never be activated for other PP handset types, since they all have $TCLw > 55$ dB.

This feature is applicable for FP Types 1b, 2, 3, 4 and 5.

7.4.3 Echo suppressor in Fixed Part

In the context of this specification, the term "echo suppressor" means an echo reduction feature, also based on signal processing but simpler than the "echo canceller", that works by detecting if there is a voice signal going in one direction on a circuit, and then inserting a great deal of loss in the other direction (see [i.19]).

A cheaper solution can be implemented with an echo suppressor instead of echo cancellation. This kind of devices will decrease the perceived quality but the result may be better than clearly audible echo due to the combination of low $TCLw$ PPs with long delay (VoIP) networks.

Echo suppression is only recommended for type 1a PPs (Classic GAP handsets) with $TCL_w < 46$ dB ("not Full TCL_w "). For "Full TCL_w " PPs ($TCL_w > 46$ dB), echo suppression is not recommended since it is considered that it does not worth introducing the quality issues of this type of echo reduction to cancel a moderate echo.

The echo suppression shall be disabled for PPs reporting a $TCL_w > 46$ dB.

The feature may be used also for type 2a PPs with $42 < TCL_w < 46$ dB. In such a case the echo suppressor should be able to operate over the wideband frequency range.

The echo suppressor should be implemented taken into account the constraints described in clause 7.4.1.

NOTE: The only PP types that may require this echo suppression feature are the types 1a and 2a. The feature should never be activated for other PP handset types, since they all have $TCL_w > 55$ dB.

This feature is applicable for FP Types 1b, 2, 3, 4 and 5.

7.5 Transmission characteristics for Portable Parts

7.5.1 Transmission characteristics for Portable Part type 1a ("Classic GAP" handset)

7.5.1.1 PP frequency responses

7.5.1.1.1 Sending

The sending sensitivity-frequency response (from MRP to the digital interface) shall be within a mask as defined in table 7.6.

Table 7.6: Sending sensitivity-frequency mask

Frequency (Hz)	Upper limit (dB)	Lower limit (dB)
100	-9	
200	0	
300	0	-14
800	0	-10
2 000	4	-8
3 400	4	-11
4 000	4	
8 000	-13	
NOTE 1: The limits at intermediate frequencies lie on a straight line drawn between the given values on a log (frequency) - linear (dB) scale.		
NOTE 2: All dB levels are on an arbitrary scale.		

7.5.1.1.2 Receiving

The receiving sensitivity-frequency response (from the digital interface to the ERP) shall be within a mask as defined in table 7.7.

Table 7.7: Receiving sensitivity-frequency mask

Frequency (Hz)	Upper limit (dB)	Lower limit (dB)
100	-10	
200	2	
300	2	-9
1 000	2	-7
3 400	2	-12
4 000	2	
8 000	-15	
NOTE 1: The limits at intermediate frequencies lie on a straight line drawn between the given values on a log (frequency) - linear (dB) scale.		
NOTE 2: All dB levels are on an arbitrary scale.		

7.5.1.2 PP sending and receiving loudness ratings

7.5.1.2.1 Nominal values

The nominal values are:

- Sending Loudness Rating (SLR_H) = 8 dB; and
- Receiving Loudness Rating (RLR_H) = 2 dB.

There is a manufacturing tolerance of $\pm 3,5$ dB on both RLR_H and SLR_H .

NOTE: ITU-T test methods on loudness ratings are valid only for codecs that can transmit sinusoids without excessive distortion.

7.5.1.2.2 User-controlled volume control in PP

A user-controlled volume control shall be provided in all PP equipment, except where an adaptive volume control is incorporated in the PP.

When adjusting the volume control from nominal setting (where RLR_H is closest to its nominal value) to maximum setting, the decrease in RLR_H shall be not less than 6 dB.

A user-controlled volume control can be implemented either as a receiving volume control (where RLR_H is changed) or as a "joint-acting" volume control (where SLR_H and RLR_H are simultaneously changed in opposite directions). For both types of volume control RLR_H and SLR_H shall simultaneously meet the values given in clause 7.5.1 (including the tolerances) for at least one setting of the volume control.

The RLR_H and SLR_H shall not exceed the limits given in tables 7.8 and 7.9.

Table 7.8: Absolute limits for "joint-acting" volume control

Volume setting	Maximum	Minimum
RLR_H	-13 dB	19 dB
SLR_H	17 dB	3 dB

Table 7.9: Absolute limits for a receiving volume control

Volume setting	Maximum	Minimum
RLR_H	-13 dB	19 dB

NOTE 1: Minimum setting: The setting where the RLR has its maximum value.

Maximum setting: The setting where the RLR has its minimum value.

NOTE 2: A user-controlled volume control should include an automatic reset function that ensures that the default setting for each new call is no louder than the nominal setting.

NOTE 3: The basic DECT requirements (echo control, signal levels for A/D converters, etc.) are optimized for digital (ISDN) transmission characteristics. Analog networks (see TBR 038 [29]) require higher receive levels (lower RLR) than digital networks (ISDN). This is to compensate for old long lossy analog lines that still exist in many PSTNs. Most of the calls do not have lossy lines. Analog transmissions over a modern network (from equipment using TBR 038 [29] values of SLR and RLR) will thus often provide higher receive levels than a digital (ISDN) connection would. This gives an interworking problem between analog networks and terminals that use digital codecs as in DECT systems and ISDN terminals, which could cause distortion in the A/D converters and also lower the margin for the wanted terminal echo loss. Therefore, considering that DECT PPs have a volume control with at least 6 dB gain to compensate for lossy connections, it should be allowed to design DECT FP equipment with a receive gain providing typical 4 dB to 6 dB higher nominal RLR (for FP + PP) than specified in relevant attachment requirements to the PSTN (see TBR 038 [29]).

7.5.1.2.3 PP adaptive volume control

The PP shall inform the FP if an adaptive volume control is implemented in the PP. Clause 7.7.41 in EN 300 175-5 [5] describes how this shall be done.

7.5.1.3 Sidetone

7.5.1.3.1 Talker sidetone

The sidetone path shall be implemented in the PP.

The nominal value of the Sidetone Masking Rating (STMR) shall be 13 dB. There is a manufacturing tolerance of -3 dB to +5 dB. The requirement shall be met with SLR_H and RLR_H corrected to the nominal values of SLR_H and RLR_H .

NOTE: It is recommended that the sidetone level is independent of the receiving volume control.

7.5.1.3.2 Listener sidetone

There are no mandatory requirements on Listener Sidetone Rating, LSTR and the weighted average D.

NOTE 1: It is recommended that the value of the LSTR is not less than 10 dB referred to the nominal values of SLR_H and RLR_H .

Alternatively it is recommended that the value of the weighted average D of the difference of the send sensitivities between diffuse and direct sound should be measured and should not be less than -5 dB.

For PPs with noise rejection capability as declared by the applicant, the value of the LSTR shall not be less than 15 dB referred to the nominal values of SLR_H and RLR_H . Alternatively the value of the weighted average D of the difference of the send sensitivities between diffuse and direct sound shall be measured and shall not be less than 0 dB.

NOTE 2: The noise rejection capability option is recommended for PPs used in noisy environments.

PPs with declared noise rejection capability option shall indicate this to the FP before or at call set-up by including this information in the <<TERMINAL CAPABILITY>> information element. See EN 300 175-5 [5], clause 7.7.41.

7.5.1.4 Terminal coupling loss

7.5.1.4.1 Weighted Terminal Coupling Loss (TCLw)

The weighted Terminal Coupling Loss (TCLw) defined from the PP digital input to the PP digital output shall meet one of the following options:

- a) $TCLw > 46$ dB at nominal setting of the volume control corrected to the nominal values of RLR_H and SLR_H .
For all positions of volume control the TCLw shall not be less than 35 dB.

NOTE 1: This is the recommended option.

- b) $TCLw > 34$ dB.

NOTE 2: Since there is no statement for option b) on volume control settings, the conditions in clause 6.3 apply.

If the PP is of type a) then it shall send this information "Full TCL" to the FP as defined in EN 300 175-5 [5], clause 7.7.41 (Terminal Capability) before or at call set-up.

If the FP receives no information concerning the TCLw value of the PP, the FP shall default to the assumption that the PP is of type b).

7.5.1.4.1.1 Test conditions

The PP shall be suspended in free air.

7.5.1.4.2 Stability loss

7.5.1.4.2.1 Requirement

In the test conditions described below the attenuation from the digital input to the digital output shall be at least 6 dB at all frequencies in the range of 200 Hz to 4 000 Hz.

7.5.1.4.2.2 Test conditions

7.5.1.4.2.2.1 Fixed geometry PP

The handset shall be lying on, and the transducers facing, a hard surface.

7.5.1.4.2.2.2 Variable geometry PP

The equipment shall be capable of meeting the requirement in at least one of the two following conditions:

- a) if it is possible to position the earpiece in front of the mouthpiece with a distance of 150 mm between the front planes of each, the requirement shall be met in this relative position and in the just off-hook position;
- b) if the relative movement and orientation of the acoustic and electro-magnetic elements are limited by means of a hinge or similar mechanism, the requirement shall be met in any relative position and orientation that can be achieved whilst the PP is in active condition, i.e. a communication is established over the air interface.

7.5.1.5 Distortion

7.5.1.5.1 Sending

The ratio of signal to total distortion (harmonic and quantizing) measured at the line interface shall not be less than 35 dB.

7.5.1.5.2 Receiving

The ratio of signal to total distortion (harmonic and quantizing) measured at the ERP shall not be less than 33 dB.

7.5.1.5.3 Sidetone

The third harmonic distortion generated by the PP shall not be greater than 10 %.

7.5.1.6 Out of band signals

7.5.1.6.1 Sending (discrimination against out of band input signals)

With any sine-wave signal above 4,6 kHz and up to 8 kHz applied at the MRP at a level of -4,7 dBPa, the level of any image frequency produced at the digital interface shall be below a reference level obtained at 1 kHz (-4,7 dBPa at MRP) by at least the amount in dB specified in table 7.10.

Table 7.10: Discrimination levels - sending

Applied sine wave frequency	Limit (minimum)
4,6 kHz	30 dB
8,0 kHz	40 dB

The limits at intermediate frequencies lie on a straight line drawn between the given values on a log (frequency) - linear (dB) scale.

7.5.1.6.2 Receiving (spurious out of band signals)

With a digitally-simulated sine-wave signal in the frequency range of 300 Hz to 3 400 Hz at a level of -10 dBm0 applied at the digital interface, the level of spurious out-of-band image signals in the frequency range of 4,6 kHz to 8 kHz measured selectively at the ERP shall be lower than the in-band acoustic level produced by a digital signal at 1 kHz set at the level specified in table 7.11.

Table 7.11: Discrimination levels - receiving

Image signal frequency	Equivalent input level
4,6 kHz	-35 dBm0
8,0 kHz	-45 dBm0

The limits at intermediate frequencies lie on a straight line drawn between the given values on a log (frequency) - linear (dB) scale.

7.5.1.7 Noise

7.5.1.7.1 Sending

The noise produced by the apparatus in the sending direction shall not exceed -64 dBm0p.

7.5.1.7.2 Band-limited noise

The narrow-band noise (due to TDMA) produced by the apparatus in the sending direction, and contained within any 10 Hz bandwidth between the frequency limits 300 Hz to 3 400 Hz, shall not exceed -73 dBm0.

7.5.1.7.3 Receiving

If no user-controlled receiving volume control is provided, or if it is provided, at the setting where the RLR_H is equal to the nominal value, the noise produced by the apparatus and measured at the ERP shall not exceed -54 dBPa(A).

7.5.1.7.4 Level of sampling frequency (receiving)

The level of the 8 kHz measured selectively at the ERP shall be less than -70 dBPa.

7.5.1.8 Acoustic shock

In order to fulfil the acoustic shock requirements, it is recommended to follow the guidelines of ITU-T Recommendation P.360 [33]. If needed the PP may have to implement some kind of hardware limiter.

7.5.1.8.1 Continuous signal

With a digitally encoded signal representing the maximum possible signal level at the digital interface, the sound pressure level at the ERP shall not exceed 24 dBPa (rms unweighted).

7.5.1.8.2 Peak signal

The receiving equipment shall limit the peak sound pressure at the ERP to less than 36 dBPa under any continuous or transient condition.

7.5.1.9 PP Delay

The sum of the delays from the MRP to the air interface and from the air interface to the ERP (round-trip delay) shall not exceed 19,5 ms. This value includes the 5 ms delay of the reference FP looping back the ADPCM digital signal towards the PP.

7.5.1.10 PP ambient noise rejection

The PP ambient noise rejection performance is defined by the D value as described in ITU-T Recommendation G.111 [24]. The D value is not measured, but a value is required for insertion in the FP adaptive volume control algorithm. The D value is derived from the STMR and LSTR specifications.

The FP adaptive volume control shall use the following values:

- D = -3 for PPs without declared noise rejection capability;
- D = 2 for PPs with declared noise rejection capability.

7.5.2 Additional requirements for PP type 1b ("improved GAP" handset)

All requirements defined for type 1a (clause 7.5.1) apply with the following differences.

7.5.2.1 Terminal coupling loss

7.5.2.1.1 Weighted Terminal Coupling Loss (TCLw)

Requirement:

The TCLw defined from the PP digital input to the PP digital output shall be ≥ 55 dB.

With the volume control set to maximum TCLw shall be ≥ 46 dB. It is recommended to set back the volume control to nominal level at the establishment of each new call, if the TCLw does not reach 55 dB at the selected volume control.

Test conditions:

The PP shall be suspended in free air.

Measurement method:

See EN 300 176-2 [10].

7.5.2.2 Attenuation Range in Sending Direction during Double Talk $A_{H,S,dt}$

Requirement:

Based on the level variation in sending direction during double talk $A_{H,S,dt}$ the behavior of the terminal can be classified according to table 7.12.

Table 7.12: Category regarding "duplex capability" depending on $A_{H,S,dt}$

Category (according to ITU-T P.340 [22])	1	2a	2b	2c	3
	Full Duplex Capability	Partial Duplex Capability			No Duplex Capability
$A_{H,S,dt}$ [dB]	≤ 3	≤ 6	≤ 9	≤ 12	> 12

In general this table provides a quality classification of terminals regarding double talk performance. However, this does not mean that a terminal which is category 1 based on the double talk performance is of high quality concerning the overall quality as well.

Measurement method:

See EN 300 176-2 [10].

7.5.2.3 Attenuation Range in Receiving Direction during Double Talk $A_{H,R,dt}$ **Requirement:**

Based on the level variation in receiving direction during double talk $A_{H,R,dt}$ the behavior of the terminal can be according to table 7.13.

Table 7.13: Category regarding "duplex capability" depending on $A_{H,R,dt}$

Category (according to ITU-T P.340 [22])	1	2a	2b	2c	3
	Full Duplex Capability	Partial Duplex Capability			No Duplex Capability
$A_{H,R,dt}$ [dB]	≤ 3	≤ 5	≤ 8	≤ 10	> 10

In general this table provides a quality classification of terminals regarding double talk performance. However, this does not mean that a terminal which is category 1 based on the double talk performance is of high quality concerning the overall quality as well.

Measurement method:

See EN 300 176-2 [10].

7.5.2.4 Activation in Sending Direction

The activation in sending direction is mainly determined by the built-up time $T_{r,S,min}$ and the minimum activation level ($L_{S,min}$). The minimum activation level is the level required to remove the inserted attenuation in sending direction during idle mode. The built-up time is determined for the test signal burst which is applied with the minimum activation level.

The activation level described in the following is always referred to the test signal level at the Mouth Reference Point (MRP).

Requirements:

The minimum activation level $L_{S,min}$ shall be ≤ -20 dBPa.

The built-up time $T_{r,S,min}$ (measured with minimum activation level) should be ≤ 15 ms.

Measurement method:

See EN 300 176-2 [10].

7.5.2.5 Activation in Receiving Direction

The activation in sending direction is mainly determined by the built-up time $T_{r,R,min}$ and the minimum activation level ($L_{R,min}$). The minimum activation level is the level required to remove the inserted attenuation in receiving direction during idle mode. The built-up time is determined for the test signal burst which is applied with the minimum activation level.

The activation level described in the following is always referred to the test signal level at the electrical reference point (POI).

Requirements:

The minimum activation level $L_{R,min}$ shall be $\leq -35,7$ dBm0 (measured during the active signal part).

The built-up time $T_{r,R,min}$ (measured with minimum activation level) shall be ≤ 15 ms.

Measurement method:

See EN 300 176-2 [10].

7.5.3 Transmission characteristics for PP types 1c and 1d (HATS tested, narrowband telephony handsets)

7.5.3.1 PP frequency responses

7.5.3.1.1 Sending

Requirement:

The send frequency response of the handset or the headset shall be within a mask as defined in table 7.14 and shown in figure 7.3. This mask shall be applicable for all types of handsets and headsets.

Table 7.14: Sending frequency response

Send frequency response		
Frequency	Upper Limit	Lower Limit
100 Hz	-5	
300 Hz	5	- ∞
300 Hz	5	-5
3 400 Hz	5	-5
3 400 Hz	5	- ∞
3 758 Hz	5	
4 000 Hz	5	

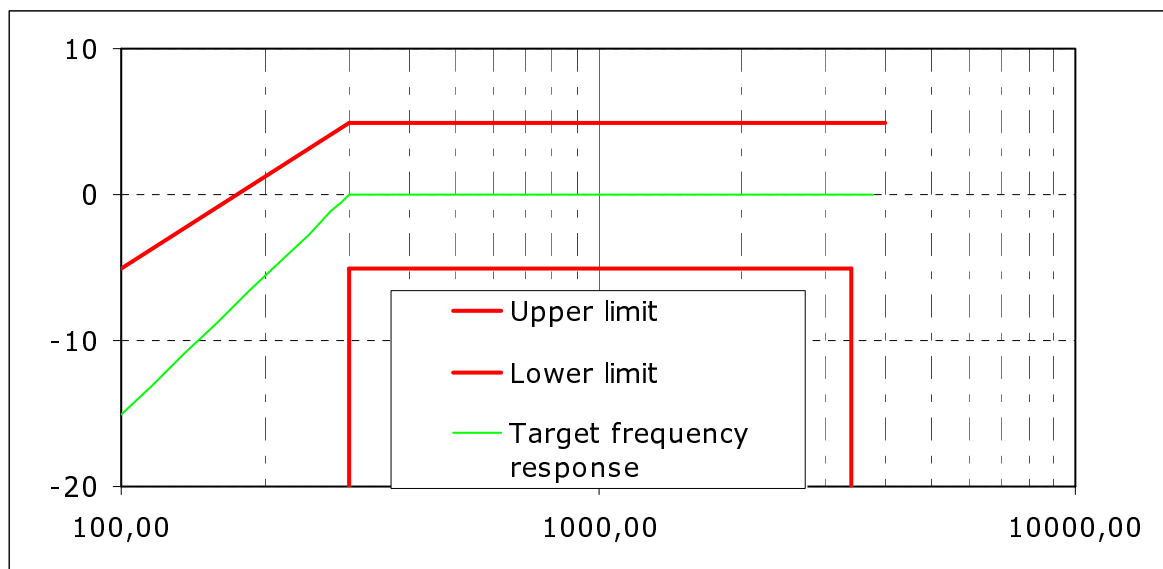

Figure 7.3: Send frequency response mask for PP types 1c and 1d

NOTE: The basis for the target frequency responses in sending and receiving is the orthotelephonic reference response which is measured between 2 subjects in 1 m distance under free field conditions and is assuming an ideal receive characteristic. Under these conditions the overall frequency response shows a rising slope. In opposite to other standards the present document no longer uses the ERP as the reference point for receiving but the diffuse-field. With the concept of diffuse-field based receive measurements a rising slope for the overall frequency response is achieved by a flat target frequency response in sending and a diffuse field based receiving frequency response.

The limit curves shall be determined by straight lines joining successive co-ordinates given in the table, where frequency response is plotted on a linear dB scale against frequency on a logarithmic scale as a floating or "best fit" mask.

Measurement method:

See EN 300 176-2 [10].

7.5.3.1.2 Receiving

Requirement:

The receive frequency response of the handset or the headset shall be within a mask as defined in table 7.15 and shown in figures 7.4, 7.5 and 7.6. The application force for handsets is 2N, 8N and 13N. This mask defined for 8 N application force shall be applicable for all types of headsets.

Table 7.15: Receiving frequency response

Frequency (Hz)	Upper Limit 8N applicable to Receive Frequency Response Mask standard and improved	Lower Limit 8N applicable to standard and improved	Upper Limit 13N applicable only to improved	Lower Limit 13N applicable only to improved	Upper Limit 2N applicable only to improved	Lower Limit 2N applicable only to improved
100	4		6		11	
300	4	-4	6	-6	11	-11
1 500	4	-4	6	-6	11	-11
3 000	4	-4	6	-6	11	-8
3 400	4	-4	6	-6	11	-8
4 000	4		6		11	

NOTE: The basis for the target frequency responses in sending and receiving is the orthotelephonic reference response which is measured between 2 subjects in 1 m distance under free field conditions and is assuming an ideal receive characteristic. Under these conditions the overall frequency response shows a rising slope. In opposite to other standards the present document no longer uses the ERP as the reference point for receiving but the diffuse-field. With the concept of diffuse-field based receive measurements a rising slope for the overall frequency response is achieved by a flat target frequency response in sending and a diffuse field based receiving frequency response.

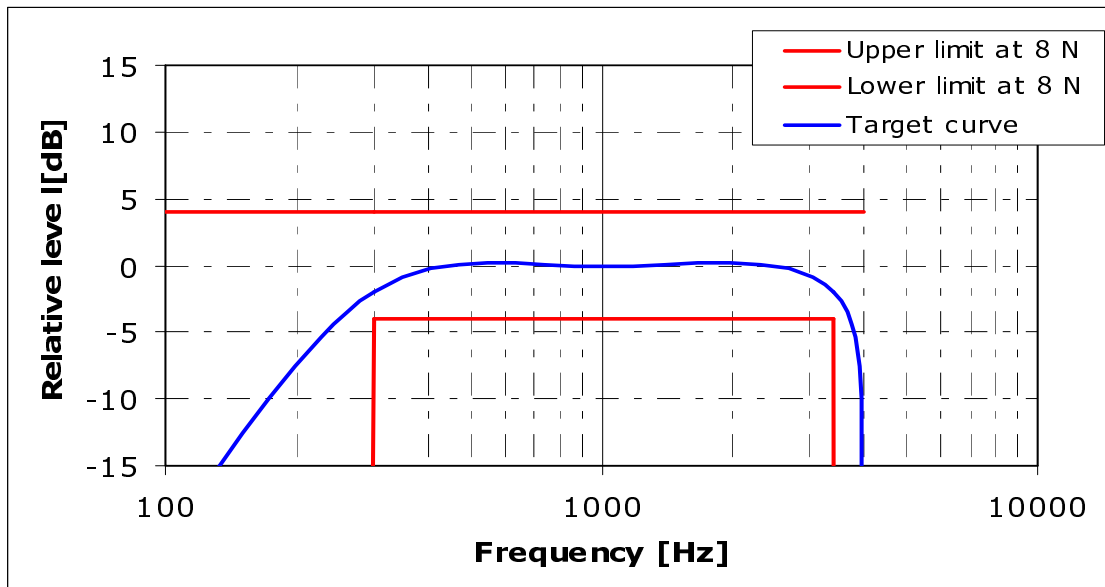

Figure 7.4: Receive frequency response mask for 8N application force

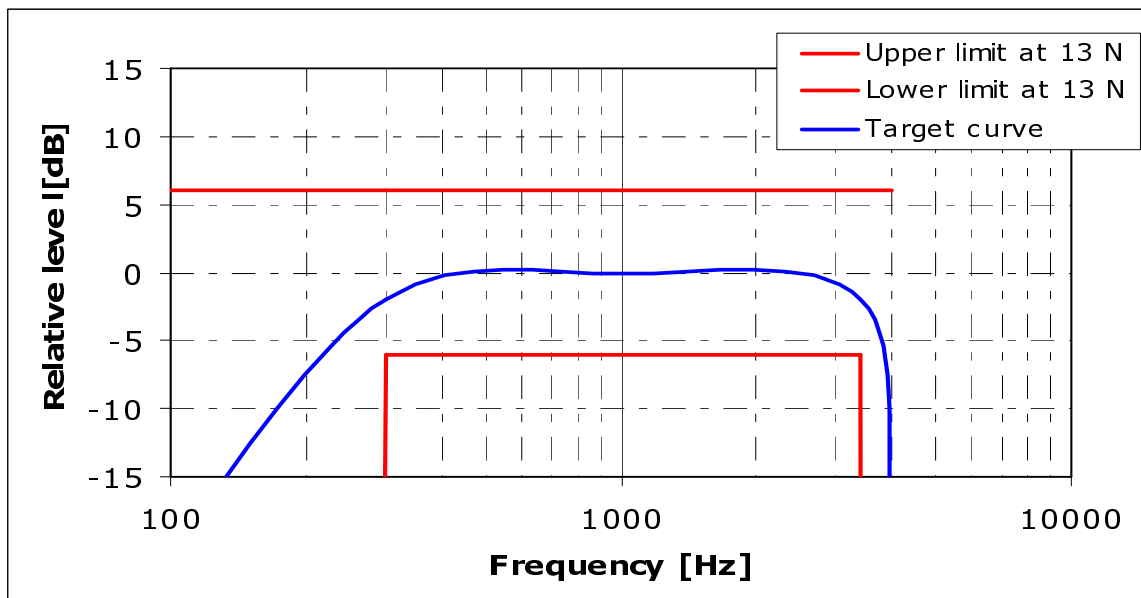

Figure 7.5: Receive frequency response mask for 13N application force

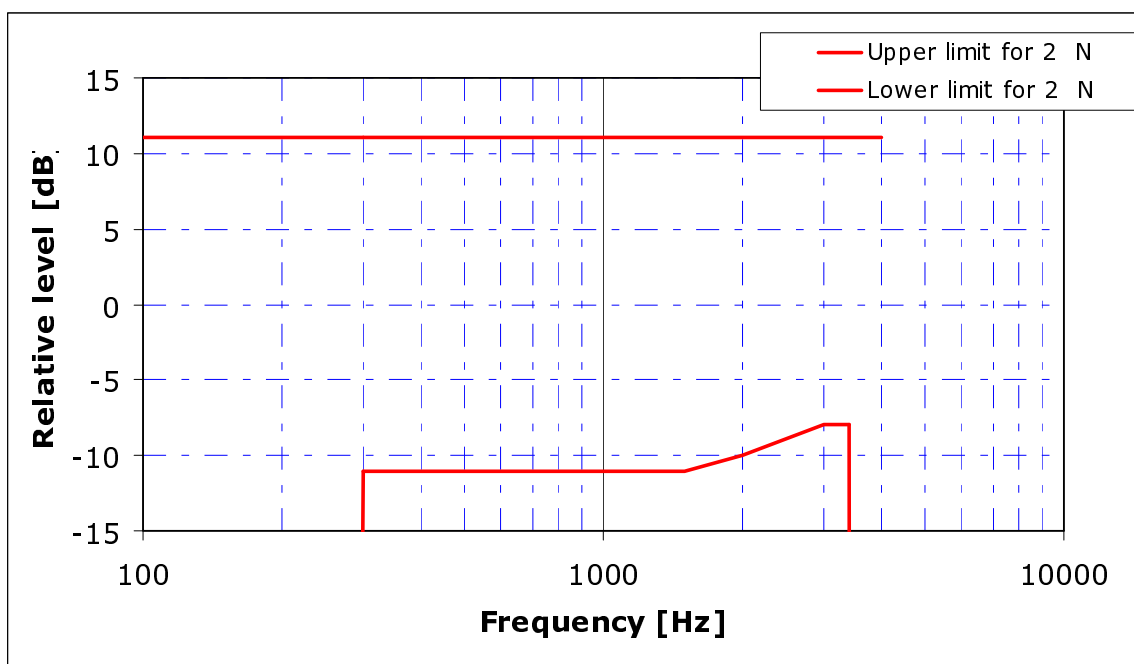

Figure 7.6: Receive frequency response mask for 2 N application force

The limit curves shall be determined by straight lines joining successive co-ordinates given in the table, where frequency response is plotted on a linear dB scale against frequency on a logarithmic scale as a floating or "best fit" mask.

Measurement method:

See EN 300 176-2 [10].

7.5.3.2 PP sending and receiving loudness ratings

7.5.3.2.1 Nominal values

7.5.3.2.1.1 Sending Loudness Rating

Requirement:

The nominal value of Send Loudness Rating (SLR) shall be:

$$\text{SLR}(\text{set}) = 8 \text{ dB} \pm 3,5 \text{ dB.}$$

Measurement method:

See EN 300 176-2 [10].

7.5.3.2.1.2 Receive Loudness Rating

Requirement:

The nominal value of Receive Loudness Rating (RLR) shall be:

$$\text{RLR}(\text{set}) = 2 \text{ dB} \pm 3,5 \text{ dB.}$$

RLR (binaural headset) = 8 dB \pm 3,5 dB for each earphone.

Measurement method:

See EN 300 176-2 [10].

7.5.3.2.2 User-controlled volume control in PP

Requirement:

A user-controlled volume control shall be provided in all PP equipment, except where an adaptive volume control is incorporated in the PP.

When adjusting the volume control from nominal setting (where RLR_H is closest to its nominal value) to maximum setting, the decrease in RLR_H shall be not less than 6 dB.

A user-controlled volume control can be implemented either as a receiving volume control (where RLR_H is changed) or as a "joint-acting" volume control (where SLR_H and RLR_H are simultaneously changed in opposite directions). For both types of volume control RLR_H and SLR_H shall simultaneously meet the values given in clause 7.5.3.2.1 (including the tolerances) for at least one setting of the volume control. Joint acting volume could be useful for noisy environment where user increase his voice level (Lombard effect) when using volume control for RLR at maximum setting (see table 7.16). In this case this system ensures a reduction in transmitted noise, compared to voice.

The RLR_H and SLR_H shall not exceed the limits given in tables 7.16 and 7.17.

Table 7.16: Absolute limits for "joint-acting" volume control

Volume setting	Maximum	Minimum
RLR_H	-13 dB	19 dB
SLR_H	17 dB	3 dB

Table 7.17: Absolute limits for a receiving volume control

Volume setting	Maximum	Minimum
RLR_H	-13 dB	19 dB

NOTE 1: Minimum setting: The setting where the RLR has its maximum value.
Maximum setting: The setting where the RLR has its minimum value.

NOTE 2: A user-controlled volume control should include an automatic reset function that ensures that the default setting for each new call is no louder than the nominal setting.

NOTE 3: The basic DECT requirements (echo control, signal levels for A/D converters, etc.) are optimized for digital (ISDN) transmission characteristics. Analog networks (see TBR 038 [29]) require higher receive levels (lower RLR) than digital networks (ISDN). This is to compensate for old long lossy analog lines that still exist in many PSTNs. Most of the calls do not have lossy lines. Analog transmissions over a modern network (from equipment using TBR 038 [29] values of SLR and RLR) will thus often provide higher receive levels than a digital (ISDN) connection would. This gives an interworking problem between analog networks and terminals that use digital codecs as in DECT systems and ISDN terminals, which could cause distortion in the A/D converters and also lower the margin for the wanted terminal echo loss. Therefore, noting that DECT PPs have a volume control with at least 6 dB gain to compensate for lossy connections, it should be allowed to design DECT FP equipment with a receive gain providing typical 4 dB to 6 dB higher nominal RLR (for FP + PP) than specified in relevant attachment requirements to the PSTN (see TBR 038 [29]).

Measurement method:

See EN 300 176-2 [10].

7.5.3.2.3 PP adaptive volume control

Requirement:

The PP shall inform the FP if an adaptive volume control is implemented in the PP. Clause 7.7.41 in EN 300 175-5 [5] shall be done.

Measurement method:

See EN 300 176-2 [10].

7.5.3.3 Sidetone

7.5.3.3.1 Talker sidetone

Requirement:

The STMR shall be 16 dB \pm 4 dB for nominal setting of the volume control.

For all other positions of the volume control, the STMR must not be below 8 dB.

NOTE: It is preferable to have a constant STMR independent of the volume control setting.

Measurement method:

See EN 300 176-2 [10].

7.5.3.3.2 D Factor

Requirement:

The D Factor shall be:

D Factor \geq -5 dB.

For PPs with noise rejection capability as declared by the applicant:

D Factor \geq 2 dB.

NOTE 1: The noise rejection capability option is recommended for PPs used in noisy environments.

PPs with declared noise rejection capability option shall indicate this to the FP before or at call set-up by including this information in the <<TERMINAL CAPABILITY>> information element. See EN 300 175-5 [5], clause 7.7.41.

NOTE 2: It should be checked that noise rejection capability does not create impairments on speech signal.

Measurement method:

See EN 300 176-2 [10].

7.5.3.3.3 Sidetone delay

Requirement:

The maximum sidetone-round-trip delay shall be \leq 5 ms.

Measurement method:

See EN 300 176-2 [10].

7.5.3.4 Terminal coupling loss

7.5.3.4.1 TCLw of Portable Part

Requirement:

The TCLw shall be \geq 55 dB.

With the volume control set to maximum TCLw shall be \geq 46 dB.

It is recommended to set back the volume control to nominal level at the establishment of each new call, if TCLw does not reach 55 dB at the selected volume control.

Measurement method:

See EN 300 176-2 [10].

7.5.3.4.2 Stability loss

Requirement:

With the handset lying on and the transducers facing a hard surface, the attenuation from the digital input to the digital output shall be at least 6 dB at all frequencies in the range of 200 Hz to 4 kHz. In case of headsets the requirement applies for the closest possible position between microphone and headset receiver.

NOTE: Depending on the type of headset it may be necessary to repeat the measurement in different positions.

Measurement method:

See EN 300 176-2 [10].

7.5.3.5 Distortion

7.5.3.5.1 Sending Distortion

Requirement:

The ratio of signal to harmonic distortion shall be above the following mask.

Table 7.18: Mask for signal to harmonic distortion (sending)

Frequency	Ratio
315 Hz	26 dB
400 Hz	30 dB
1 kHz	30 dB

Limits at intermediate frequencies lie on a straight line drawn between the given values on a linear (dB ratio) - logarithmic (frequency) scale.

Measurement method:

See EN 300 176-2 [10].

7.5.3.5.2 Receiving Distortion

Requirement:

The ratio of signal to harmonic distortion shall be above the following mask.

Table 7.19: Mask for signal to harmonic distortion (receiving)

Frequency	Signal to distortion ratio limit, receiving
315 Hz	26 dB
400 Hz	30 dB
500 Hz	30 dB
800 Hz	30 dB
1 kHz	30 dB

Limits at intermediate frequencies lie on a straight line drawn between the given values on a linear (dB ratio) - logarithmic (frequency) scale.

Measurement method:

See EN 300 176-2 [10].

7.5.3.6 Out of band signals

7.5.3.6.1 Out-of-Band Signals in Send direction

Requirement:

With any signal above 4,6 kHz and up to 8 kHz applied at the MRP at a level of -4,7 dBPa, the level of any image frequency shall be below the level obtained for the reference signal by at least the amount (in dB) specified in table 7.20.

Table 7.20: Out-of-band signal limit, sending

Frequency (kHz)	Signal limit (dB)
4,6	30
8	40
NOTE: The limits for intermediate frequencies lie on a straight line drawn between the given values on a linear (dB) - logarithmic (kHz) scale.	

Measurement method:

See EN 300 176-2 [10].

7.5.3.6.2 Out-of-band signals in receiving direction

Requirement:

With a digitally-simulated sine-wave signal in the frequency range of 300 Hz to 3 400 Hz at a level of -10 dBm0 applied at the digital interface, the level of spurious out-of-band image signals in the frequency range of 4,6 kHz to 8 kHz measured selectively at the ERP shall be lower than the in-band acoustic level produced by a digital signal at 1 kHz set at the level specified in table 7.21.

Table 7.21: Discrimination levels - receiving

Image signal frequency	Equivalent input level
4,6 kHz	-35 dBm0
8,0 kHz	-45 dBm0

The limits at intermediate frequencies lie on a straight line drawn between the given values on a log (frequency) - linear (dB) scale.

Measurement method:

See EN 300 176-2 [10].

7.5.3.7 Noise

7.5.3.7.1 Sending

Requirement:

The maximum noise level produced by the VoIP terminal at the POI under silent conditions in the sending direction shall not exceed -64 dBm0p.

No peaks in the frequency domain higher than 10 dB above the average noise spectrum shall occur.

Measurement method:

See EN 300 176-2 [10].

7.5.3.7.2 Receiving

Requirement:

Telephone sets with adjustable receive levels shall be adjusted so that the RLR is as close as possible to the nominal RLR.

The receive noise shall be less than -54 dBPa(A).

It is recommended that noise does not exceed -57 dBPa(A) at nominal setting of volume control, when provided, and that the measured noise shall not be greater than -54 dBPa(A) at the maximum setting of the volume control.

Measurement method:

See EN 300 176-2 [10].

7.5.3.8 Acoustic shock

In order to fulfil the acoustic shock requirements, it is recommended to follow the guidelines of ITU-T Recommendation P.360 [33]. If needed the PP may have to implement some kind of hardware limiter.

7.5.3.8.1 Continuous signal

Requirement:

With a digitally encoded signal representing the maximum possible signal level at the digital interface, the sound pressure level at the ERP shall not exceed 24 dBPa (rms unweighted).

Measurement method:

See EN 300 176-2 [10].

7.5.3.8.2 Peak signal

Requirement:

The receiving equipment shall limit the peak sound pressure at the ERP to less than 36 dBPa under any continuous or transient condition.

Measurement method:

See EN 300 176-2 [10].

7.5.3.9 Delay

The sum of the delays from the MRP to the air interface and from the air interface to the ERP (round-trip delay) shall not exceed 19,5 ms. This value includes the 5 ms delay of the reference FP looping back the ADPCM digital signal towards the PP.

NOTE: For other codecs some information about the extra delay added may be found in clause F.1.

7.5.3.10 Variation of gain with input level-sending

Requirement:

The sensitivity determined with input sound pressure levels between -24,7 dBPa and 5,3 dBPa shall not differ by more than ± 2 dB from the sensitivity determined with an input sound pressure level of -4,7 dBPa. For the input sound pressure level of 5,3 dBPa a limit of +4/-2 dB applies.

Table 7.22: Linearity range of SLR: $\Delta SLR = SLR - SLR@-4,7$ dBPa

Input Level	Target ΔSLR	Upper limit	Lower limit
-24,7 dBPa	0	2,00 dB	-2 dB
-19,7 dBPa	0	2,00 dB	-2 dB
-14,7 dBPa	0	2,00 dB	-2 dB
-9,7 dBPa	0	2,00 dB	-2 dB
-4,9 dBPa	0	2,00 dB	-2 dB
-4,7 dBPa	0	0 dB	0,00 dB
-4,5 dBPa	0	2,00 dB	-2,00 dB
0,3 dBPa	0	2,00 dB	-2,00 dB
5,3 dBPa	0	4,00 dB	-4,00 dB

NOTE: It is assumed that the variation of gain is mostly codec independent. In case codec specific requirements are needed this is found in the codec specific section.

Measurement method:

See EN 300 176-2 [10].

7.5.3.11 Double Talk Performance

NOTE: Those parameters are optional, but are strongly recommended for improved class.

During double talk the speech is mainly determined by 2 parameters: impairment caused by echo during double talk and level variation between single and double talk (attenuation range).

In order to guarantee sufficient quality under double talk conditions the Talker Echo Loudness Rating (TELR) should be high and the attenuation inserted should be as low as possible. Terminals which do not allow double talk in any case should provide a good echo attenuation which is realized by a high attenuation range in this case.

The most important parameters determining the speech quality during double talk are (see ITU-T Recommendations P.340 [22] and P.502 [27]):

- Attenuation range in sending direction during double talk $A_{H,S,dt}$.
- Attenuation range in receiving direction during double talk $A_{H,R,dt}$.
- Echo attenuation during double talk.

7.5.3.11.1 Attenuation Range in Sending Direction during Double Talk $A_{H,S,dt}$ **Requirement:**

Based on the level variation in sending direction during double talk $A_{H,S,dt}$ the behavior of the terminal can be classified according to table 7.23.

Table 7.23: Category regarding "duplex capability" depending on $A_{H,S,dt}$

Category (according to ITU-T P.340 [22])	1	2a	2b	2c	3
	Full Duplex Capability	Partial Duplex Capability			No Duplex Capability
$A_{H,S,dt}$ [dB]	≤ 3	≤ 6	≤ 9	≤ 12	> 12

In general this table provides a quality classification of terminals regarding double talk performance. However, this does not mean that a terminal which is category 1 based on the double talk performance is of high quality concerning the overall quality as well.

Measurement method:

See EN 300 176-2 [10].

7.5.3.11.2 Attenuation Range in Receiving Direction during Double Talk $A_{H,R,dt}$ **Requirement:**

Based on the level variation in receiving direction during double talk $A_{H,R,dt}$ the behavior of the terminal can be according to table 7.24.

Table 7.24: Category regarding "duplex capability" depending on $A_{H,R,dt}$

Category (according to ITU-T P.340 [22])	1	2a	2b	2c	3
	Full Duplex Capability	Partial Duplex Capability			No Duplex Capability
$A_{H,R,dt}$ [dB]	≤ 3	≤ 5	≤ 8	≤ 10	> 10

In general this table provides a quality classification of terminals regarding double talk performance. However, this does not mean that a terminal which is category 1 based on the double talk performance is of high quality concerning the overall quality as well.

Measurement method:

See EN 300 176-2 [10].

7.5.3.11.3 Detection of Echo Components during Double Talk

Requirement:

Echo Loss during double talk is the echo suppression provided by the terminal during double talk measured at the electrical reference point.

NOTE: The echo attenuation during double talk is based on the parameter Talker Echo Loudness Rating (TELRdt). It is assumed that the terminal at the opposite end of the connection provides nominal Loudness Rating (SLR + RLR = 10 dB).

Under these conditions the requirements given in the table below are applicable (more information can be found in annex A of the ITU-T Recommendation P.340 [22]).

Table 7.25: Category regarding "duplex capability" depending on $A_{H,R,dt}$

Category (according to ITU-T P.340 [22])	1	2a	2b	2c	3
	Full Duplex Capability	Partial Duplex Capability			No Duplex Capability
Echo Loss [dB]	≥ 27	≥ 23	≥ 17	≥ 11	< 11

Measurement method:

See EN 300 176-2 [10].

7.5.3.11.4 Minimum activation level and sensitivity of double talk detection

For further study.

7.5.3.12 Switching characteristics

NOTE 1: Those parameters are optional, but are strongly recommended for improved class.

NOTE 2: Additional requirements may be needed in order to further investigate the effect of NLP implementations on the users perception of speech quality.

7.5.3.12.1 Activation in Sending Direction

The activation in sending direction is mainly determined by the built-up time $T_{r,S,min}$ and the minimum activation level ($L_{S,min}$). The minimum activation level is the level required to remove the inserted attenuation in sending direction during idle mode. The built-up time is determined for the test signal burst which is applied with the minimum activation level.

The activation level described in the following is always referred to the test signal level at the mouth reference point (MRP).

Requirements:

The minimum activation level $L_{S,min}$ shall be ≤ -20 dBPa.

The built-up time $T_{r,S,min}$ (measured with minimum activation level) should be ≤ 15 ms.

Measurement method:

See EN 300 176-2 [10].

7.5.3.12.2 Activation in Receiving Direction

The activation in sending direction is mainly determined by the built-up time $T_{r,R,min}$ and the minimum activation level ($L_{R,min}$). The minimum activation level is the level required to remove the inserted attenuation in receiving direction during idle mode. The built-up time is determined for the test signal burst which is applied with the minimum activation level.

The activation level described in the following is always referred to the test signal level at the electrical reference point (POI).

Requirements:

The minimum activation level $L_{R,min}$ shall be $\leq -35,7$ dBm0 (measured during the active signal part).

The built-up time $T_{r,R,min}$ (measured with minimum activation level) shall be ≤ 15 ms.

Measurement method:

See EN 300 176-2 [10].

7.5.3.12.3 Silence Suppression and Comfort Noise Generation

For further study.

7.5.3.12.4 Performance in sending direction in the presence of background noise

Requirement:

The level of comfort noise, if implemented, shall be within a range of +2 dB and -5 dB compared to the original (transmitted) background noise. The noise level is calculated with psophometric weighting.

NOTE 1: It is advisable that the comfort noise matches the original signal as good as possible (from a perceptual point of view).

NOTE 2: Input for further specification necessary (e.g. on temporal matching).

The spectral difference between comfort noise and original (transmitted) background noise shall be within the mask given through straight lines between the breaking points on a logarithmic (frequency) - linear (dB sensitivity) scale as given in table 7.26.

Table 7.26: Mask for requirements for Spectral Adjustment of Comfort Noise

Frequency (Hz)	Upper Limit	Lower Limit
200	12	-12
800	12	-12
800	10	-10
2 000	10	-10
2 000	6	-6
4 000	6	-6
NOTE: All sensitivity values are expressed in dB on an arbitrary scale.		

Measurement method:

See EN 300 176-2 [10].

7.5.3.12.5 Speech Quality in the Presence of Background Noise

For further study.

7.5.3.12.6 Quality of Background Noise Transmission (with Far End Speech)

Requirement:

The test is carried out applying the Composite Source Signal in receiving direction. During and after the end of Composite Source Signal bursts (representing the end of far end speech simulation) the signal level in sending direction should not vary more than 10 dB (during transition to transmission of background noise without far end speech).

Measurement method:

See EN 300 176-2 [10].

7.5.3.12.7 Quality of background noise transmission (with Near End Speech)

Requirement:

The test is carried out applying a simulated speech signal in sending direction. During and after the end of the simulated speech signal (Composite Source Signal bursts) the signal level in sending direction should not vary more than 10 dB.

Measurement method:

See EN 300 176-2 [10].

7.5.3.13 Quality of echo cancellation

NOTE: Those parameters are optional, but are strongly recommended for improved class.

7.5.3.13.1 Temporal echo effects

Requirement:

This test is intended to verify that the system will maintain sufficient echo attenuation during single talk. The measured echo attenuation during single talk should not decrease by more than 6 dB from the maximum measured during the TCLw test.

Measurement method:

See EN 300 176-2 [10].

7.5.3.13.2 Spectral Echo Attenuation

Requirement:

The echo attenuation vs. frequency shall be below the tolerance mask given in table 7.27.

Table 7.27: Mask for echo attenuation vs. frequency

Frequency (Hz)	Upper Limit
100	-20
200	-30
300	-38
800	-34
1 500	-33
2 600	-24
4 000	-24

NOTE 1: All sensitivity values are expressed in dB on an arbitrary scale.
 NOTE 2: The limit at intermediate frequencies lies on a straight line drawn between the given values on a log (frequency) - linear (dB) scale.

During the measurement it should be ensured that the measured signal is really the echo signal and not the comfort noise which possibly may be inserted in sending direction in order to mask the echo signal.

Measurement method:

See EN 300 176-2 [10].

7.5.4 Transmission characteristics for PP types 3a and 3b (narrowband loudspeaking and handsfree devices)

7.5.4.1 Sending sensitivity/frequency response

Requirement:

The sending sensitivity/frequency response shall be within the limits given in table 7.28.

Table 7.28: Sending frequency response

Frequency (Hz)	Upper limit (dB)	Lower limit (dB)
100	5	-
200	5	-
250	5	-
315	5	-∞
315	5	-9
400	5	-8
500	5	-7
630	5	-6
800	5	-4
1 000	5	-3
1 300	7	-3
1 600	8	-3
2 000	9	-3
2 500	9	-3
3 100	9	-3
4 000	5	-∞

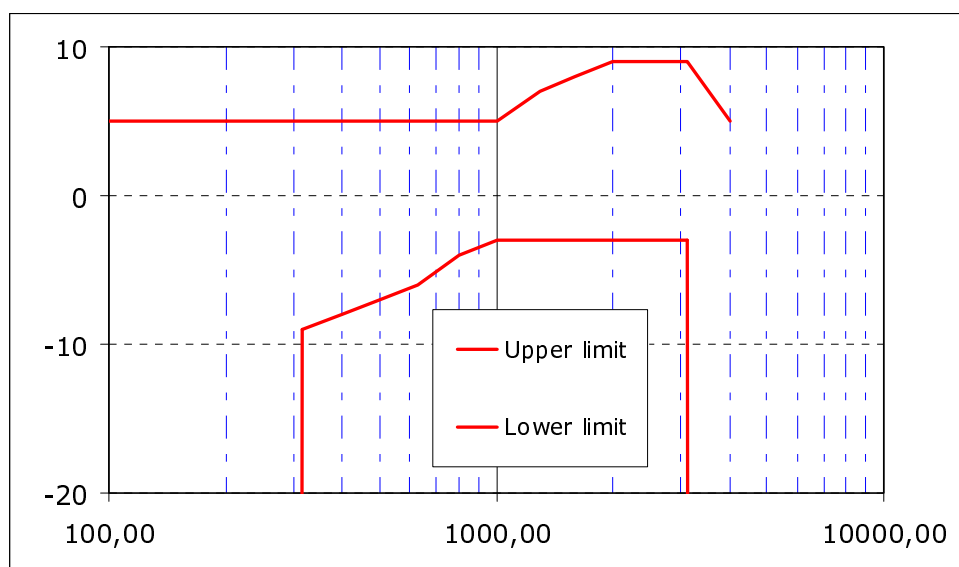

Figure 7.7: Sending sensitivity/frequency mask for HFT

Measurement method:

See EN 300 176-2 [10].

7.5.4.2 Receive sensitivity/frequency response

Requirement:

The following masks are required for handsfree and loudspeaking terminals. The mask is drawn as straight lines between the breaking points in the table on a logarithmic (frequency) - linear (dB sensitivity) scale.

- Desktop operated PP.

Table 7.29: Receiving frequency response desktop handsfree PP

Frequency (Hz)	Upper limit (dB)	Lower limit (dB)
100	6	-
200	6	-
250	6	-
315	6	-∞
315	6	-9
400	6	-6
500	6	-6
630	6	-6
800	6	-6
1 000	6	-6
1 300	6	-6
1 600	6	-6
2 000	6	-6
2 500	6	-6
3 100	6	-6
3 100	6	-∞
4 000	6	-

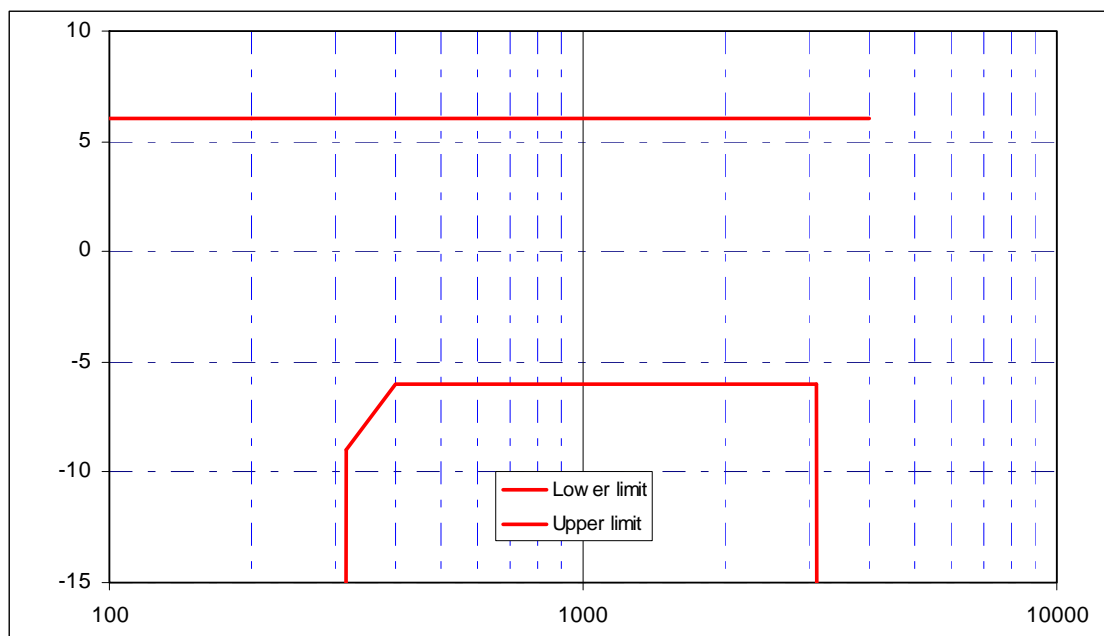
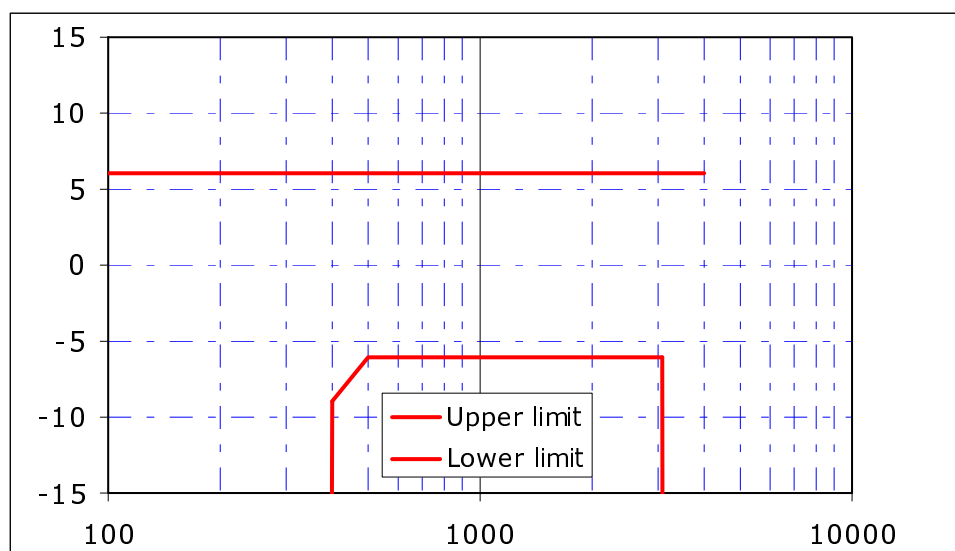

Figure 7.8: Receiving sensitivity/frequency mask for Desktop hands free PP

- Handheld operated PP:
 - Improved class.

Table 7.30: Receiving frequency response handheld handsfree PP improved

Frequency (Hz)	Upper limit (dB)	Lower limit (dB)
100	6	-
200	6	-
400	6	-∞
400	6	-9
500	6	-6
630	6	-6
800	6	-6
1 000	6	-6
1 300	6	-6
1 600	6	-6
2 000	6	-6
2 500	6	-6
3 100	6	-6
3 100	6	-∞
4 000	6	-

**Figure 7.9: Receiving sensitivity/frequency mask for Hand-held "improved" class PP**

- standard class.

Table 7.31: Receiving frequency response handheld handsfree PP standard

Frequency (Hz)	Upper limit (dB)	Lower limit (dB)
100	6	-
200	6	-
400	6	-
500	6	-∞
500	6	-9
630	6	-6
800	6	-6
1 000	6	-6
1 300	6	-6
1 600	6	-6
2 000	6	-6
2 500	6	-6
3 100	6	-6
3 100	6	-∞
4 000	6	-

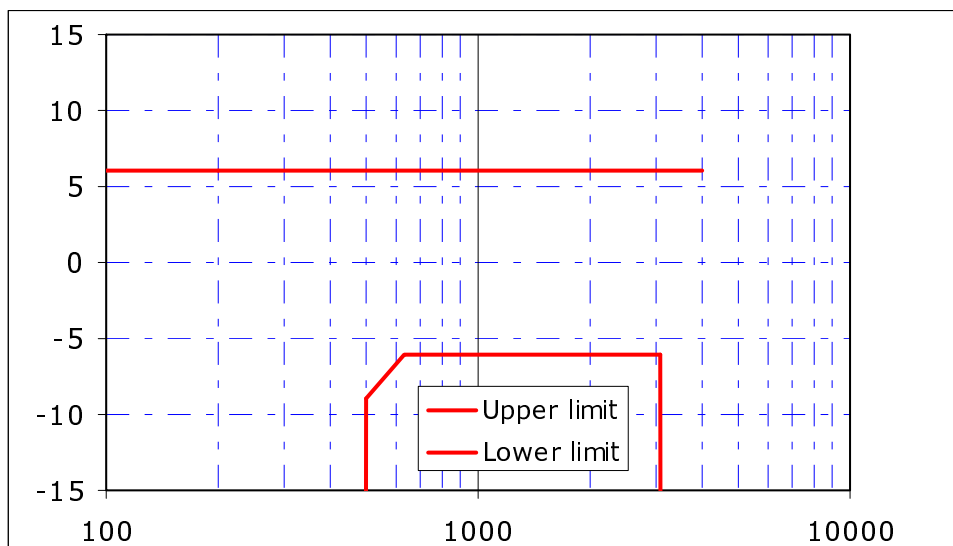

Figure 7.10: Receiving sensitivity/frequency mask for Hand-held "standard" class PP

Measurement method:

See EN 300 176-2 [10].

7.5.4.3 Sending loudness rating

Requirement:

The value of SLR shall be $+13 \text{ dB} \pm 3 \text{ dB}$.

This value is derived from Handset SLR. According to ITU-T Recommendation P.340 [22] the SLR of a hands-free telephone should be about 5 dB higher than the SLR of the corresponding handset telephone.

Measurement method:

See EN 300 176-2 [10].

7.5.4.4 Receive loudness rating

Requirement:

Desktop operated PP

Nominal value of RLR = $+5 \pm 3 \text{ dB}$. This value has to be fulfilled for one position of volume range.

Value of RLR at upper part of volume range must be less than (louder) or equal to -2 dB: $\text{RLR max} \leq -2 \text{ dB}$.

Range of volume control must be equal or exceed 15 dB: $(\text{RLR min} - \text{RLRmax}) \geq 15 \text{ dB}$.

Handheld operated PP

Improved class

Nominal value of RLR = $+9 \pm 3 \text{ dB}$. This value has to be fulfilled for one position of volume range.

Value of RLR at upper part of volume range must be less than (louder) or equal to 4 dB: $\text{RLR max} \leq +4 \text{ dB}$.

Recommended value is $\text{RLR max} \leq +2 \text{ dB}$.

Range of volume control must be equal or exceed 15 dB: $(\text{RLR min} - \text{RLR max}) \geq 15 \text{ dB}$.

Standard class

Nominal value of RLR = $+9 \pm 3$ dB. This value has to be fulfilled for one position of volume range.

Value of RLR at upper part of volume range must be less than (louder) or equal to 8 dB: $\text{RLR max} \leq +8$ dB

Recommended value is $\text{RLR max} \leq +6$ dB.

Range of volume control must be equal or exceed 15 dB: $(\text{RLR min} - \text{RLR max}) \geq 15$ dB.

Measurement method:

See EN 300 176-2 [10].

7.5.4.5 Sending distortion

Requirement:

The ratio of signal to harmonic distortion shall be above the following mask.

Table 7.32: Ratio of signal to harmonic distortion (sending)

Frequency	Ratio
315 Hz	26 dB
400 Hz	30 dB
1 kHz	30 dB

Limits at intermediate frequencies lie on a straight line drawn between the given values on a linear (dB ratio) - logarithmic (frequency) scale.

Measurement method:

See EN 300 176-2 [10].

7.5.4.6 Receiving distortion

Requirement:

The ratio of signal to harmonic distortion shall be above the following mask.

Table 7.33: Ratio of signal to harmonic distortion (receiving)

Frequency	Signal to distortion ratio limit, receiving for desktop PP at nominal volume	Signal to distortion ratio limit, receiving for improved handheld PP at nominal volume	Signal to distortion ratio limit, receiving for standard handheld PP at nominal volume	Signal to distortion ratio limit, receiving for all PP at maximum volume
315 Hz	26 dB			
400 Hz	30 dB	20 dB		
500 Hz	30 dB	20 dB	20 dB	
800 Hz	30 dB	30 dB	30 dB	20 dB
1 kHz	30 dB	30 dB	30 dB	

Limits at intermediate frequencies lie on a straight line drawn between the given values on a linear (dB ratio) - logarithmic (frequency) scale.

The ratio of signal to harmonic distortion is given in the previous table.

Limits at intermediate frequencies lie on a straight line drawn between the given values on a linear (dB ratio) - logarithmic (frequency) scale.

Measurement method:

See EN 300 176-2 [10].

7.5.4.7 Out-of-band signals in sending direction

Requirement:

With any signal above 4,6 kHz and up to 8 kHz applied at the MRP at a level of -4,7 dBPa, the level of any image frequency shall be below the level obtained for the reference signal by at least the amount (in dB) specified in table 7.34.

Table 7.34: Out-of-band signal limit (sending)

Frequency (kHz)	Signal limit (dB)
4,6	30
8	40
NOTE: The limits for intermediate frequencies lie on a straight line drawn between the given values on a linear (dB) - logarithmic (kHz) scale.	

Measurement method:

See EN 300 176-2 [10].

7.5.4.8 Out-of-band signals in receiving direction

Requirement:

Any spurious out-of-band image signals in the frequency range from 4,6 kHz to 8 kHz measured selectively shall be lower than the in-band level measured with a reference signal. The minimum level difference between the reference signal level and the out-of-band image signal level shall be as given in table 7.35.

Table 7.35: Out-of-band signal limit (receiving)

Frequency (kHz)	Signal limit (dB)
4,6	35
8	45
NOTE: The limits for intermediate frequencies lie on a straight line drawn between the given values on a linear (dB) - logarithmic (kHz) scale.	

Measurement method:

See EN 300 176-2 [10].

7.5.4.9 Sending noise

Requirement:

The limit for the maximum sending noise level shall be -64 dBm0p.

No peaks in the frequency domain higher than 10 dB above the average noise spectrum shall occur.

Measurement method:

See EN 300 176-2 [10].

7.5.4.10 Receiving noise

Requirement:

A-weighted

The noise level shall not exceed -54 dBPa(A) at **nominal setting of the volume control**.

Octave band spectrum

The level in any 1/3-octave band, between 100 Hz and 10 kHz shall not exceed a value of -64 dBPa.

NOTE: No peaks in the frequency domain higher than 10 dB above the average noise spectrum should occur.

Measurement method:

See EN 300 176-2 [10].

7.5.4.11 Terminal Coupling Loss of PP

Requirement:

Improved class

In order to meet the G.131 [30] talker echo objective requirements, the recommended weighted terminal coupling loss during single talk (TCLwst) should be greater than 55 dB when measured under free field conditions at nominal setting of volume control.

A TCLw greater than 46 dB is considered as acceptable.

TCLwst shall be not less than 40 dB for the higher gain settings above the nominal setting of the volume control.

Standard class

TCLw shall be greater than 40 dB when measured under free field conditions at nominal setting of volume control.

TCLwst shall be not less than 34 dB for the higher gain settings above the nominal setting of the volume control.

Measurement method:

See EN 300 176-2 [10].

7.5.4.12 Stability Loss of PP

Requirement:

For the calculation the averaged measured echo level at each frequency band is referred to the averaged test signal level measured in each frequency band. It shall not exceed 6 dB for all frequencies and for all settings of volume control.

Measurement method:

See EN 300 176-2 [10].

7.5.4.13 Double Talk Performance

NOTE: When those parameters are optional, they are strongly recommended for improved class.

During double talk the speech is mainly determined by 2 parameters: impairment caused by echo during double talk and level variation between single and double talk (attenuation range).

In order to guarantee sufficient quality under double talk conditions the Talker Echo Loudness Rating should be high and the attenuation inserted should be as low as possible. Terminals which do not allow double talk in any case should provide a good echo attenuation which is realized by a high attenuation range in this case.

The most important parameters determining the speech quality during double talk are (see ITU-T Recommendations P.340 [22] and P.502 [27]):

- Attenuation range in sending direction during double talk $A_{H,S,dt}$
- Attenuation range in receiving direction during double talk $A_{H,R,dt}$.
- Echo attenuation during double talk.

7.5.4.13.1 Attenuation Range in Sending Direction during Double Talk $A_{H,S,dt}$

Requirement:

Based on the level variation in sending direction during double talk $A_{H,S,dt}$ the behavior of the terminal can be classified according to table 7.36.

Table 7.36: Category regarding "duplex capability" depending on $A_{H,S,dt}$

Category (according to ITU-T P.340 [22])	1	2a	2b	2c	3
	Full Duplex Capability	Partial Duplex Capability			No Duplex Capability
$A_{H,S,dt}$ [dB]	≤ 3	≤ 6	≤ 9	≤ 12	> 12

In general this table provides a quality classification of terminals regarding double talk performance. However, this does not mean that a terminal which is category 1 or 2 based on the double talk performance is of high quality concerning the overall quality as well.

Improved PP has to be in category between 1 to 2.

Measurement method:

See EN 300 176-2 [10].

7.5.4.13.2 Attenuation Range in Receiving Direction during Double Talk $A_{H,R,dt}$ **Requirement:**

Based on the level variation in receiving direction during double talk $A_{H,R,dt}$ the behavior of the terminal can be classified according to table 7.37.

Table 7.37: Category regarding "duplex capability" depending on $A_{H,R,dt}$

Category (according to ITU-T P.340 [22])	1	2a	2b	2c	3
	Full Duplex Capability	Partial Duplex Capability			No Duplex Capability
$A_{H,R,dt}$ [dB]	≤ 3	≤ 5	≤ 8	≤ 10	> 10

In general this table provides a quality classification of terminals regarding double talk performance. However, this does not mean that a terminal which is category 1 or 2 based on the double talk performance is of high quality concerning the overall quality as well.

Improved PP has to be in category between 1 to 2.

Measurement method:

See EN 300 176-2 [10].

7.5.4.13.3 Detection of Echo Components during Double Talk**Requirement:**

"Echo Loss" is the echo suppression provided by the terminal measured at the electrical reference point. Under these conditions the requirements given in table 7.38 are applicable (more information can be found in annex A of the ITU-T Recommendation P.340 [22]).

Table 7.38: Category regarding "duplex capability" depending on Echo Loss

Category (according to ITU-T P.340 [22])	1	2a	2b	2c	3
	Full Duplex Capability	Partial Duplex Capability			No Duplex Capability
Echo Loss [dB]	≥ 27	≥ 23	≥ 17	≥ 11	< 11

NOTE: The echo attenuation during double talk is based on the parameter Talker Echo Loudness Rating ($TEL_{R_{dt}}$). It is assumed that the terminal at the opposite end of the connection provides nominal Loudness Rating ($SLR + RLR = 10$ dB).

Improved PP has to be in category between 1 to 2.

Measurement method:

See EN 300 176-2 [10].

7.5.4.13.4 Minimum activation level and sensitivity of double talk detection

For further study.

7.5.4.14 Switching characteristics

NOTE 1: When those parameters are optional, they are strongly recommended for improved class.

NOTE 2: Additional requirements may be needed in order to further investigate the effect of NLP implementations on the users perception of speech quality.

7.5.4.14.1 Activation in Sending Direction

The activation in sending direction is mainly determined by the built-up time $T_{r,S,min}$ and the minimum activation level ($L_{S,min}$). The minimum activation level is the level required to remove the inserted attenuation in sending direction during idle mode. The built-up time is determined for the test signal burst which is applied with the minimum activation level.

The activation level described in the following is always referred to the test signal level at the mouth reference point (MRP).

Requirements:

The minimum activation level $L_{s,min}$ shall be ≤ -20 dBPa.

The built-up time $T_{r,S,min}$ (measured with minimum activation level) should be ≤ 15 ms.

Measurement method:

See EN 300 176-2 [10].

7.5.4.14.2 Activation in Receiving Direction

The activation in receiving direction is mainly determined by the built-up time $T_{r,R,min}$ and the minimum activation level ($L_{R,min}$). The minimum activation level is the level required to remove the inserted attenuation in receiving direction during idle mode. The built-up time is determined for the test signal burst which is applied with the minimum activation level.

The activation level described in the following is always referred to the test signal level at the electrical reference point (POI).

Requirements:

The minimum activation level $L_{R,min}$ shall be $\leq -35,7$ dBm0 (measured during the active signal part).

The built-up time $T_{r,R,min}$ (measured with minimum activation level) shall be ≤ 15 ms.

Measurement method:

See EN 300 176-2 [10].

7.5.4.14.3 Silence Suppression and Comfort Noise Generation

For further study.

7.5.4.14.4 Performance in sending direction in the presence of background noise

Requirement:

The level of comfort noise, if implemented, shall be within a range of +2 dB and -5 dB compared to the original (transmitted) background noise. The noise level is calculated with psophometric weighting.

NOTE 1: It is advisable that the comfort noise matches the original signal as good as possible (from a perceptual point of view).

NOTE 2: Input for further specification necessary (e.g. on temporal matching).

The spectral difference between comfort noise and original (transmitted) background noise shall be within the mask given through straight lines between the breaking points on a logarithmic (frequency) - linear (dB sensitivity) scale as given in table 7.39.

Table 7.39: Mask for requirements for Spectral Adjustment of Comfort Noise

Frequency (Hz)	Upper Limit	Lower Limit
200	12	-12
800	12	-12
800	10	-10
2 000	10	-10
2 000	6	-6
4 000	6	-6

NOTE: All sensitivity values are expressed in dB on an arbitrary scale.

Measurement method:

See EN 300 176-2 [10].

7.5.4.14.5 Speech Quality in the Presence of Background Noise

For further study.

7.5.4.14.6 Quality of Background Noise Transmission (with Far End Speech)

Requirement:

The test is carried out applying the Composite Source Signal (CSS) in receiving direction. During and after the end of Composite Source Signal (CSS) bursts (representing the end of far end speech simulation) the signal level in sending direction should not vary more than 10 dB (during transition to transmission of background noise without far end speech). The measurement is conducted for all types of background noise as defined in the measurement method.

Measurement method:

See EN 300 176-2 [10].

7.5.4.14.7 Quality of background noise transmission (with Near End Speech)

Requirement:

The test is carried out applying a simulated speech signal in sending direction. During and after the end of the simulated speech signal (Composite Source Signal (CSS) bursts) the signal level in sending direction should not vary more than 10 dB.

Measurement method:

See EN 300 176-2 [10].

7.5.4.15 Quality of echo cancellation

NOTE: Those parameters are optional, but are strongly recommended for improved class.

7.5.4.15.1 Temporal echo effects

Requirement:

This test is intended to verify that the system will maintain sufficient echo attenuation during single talk. The measured echo attenuation during single talk should not decrease by more than 6 dB from the maximum measured during the TCLw test.

Measurement method:

See EN 300 176-2 [10].

7.5.4.15.2 Spectral Echo Attenuation

Requirement:

The echo attenuation vs. frequency shall be below the tolerance mask given in table 7.40.

Table 7.40: Mask for echo attenuation vs. frequency

Frequency (Hz)	Upper Limit (dB)
100	-20
200	-30
300	-38
800	-34
1 500	-33
2 600	-24
4 000	-24
NOTE 1: All sensitivity values are expressed in dB on an arbitrary scale.	
NOTE 2: The limit at intermediate frequencies lies on a straight line drawn between the given values on a log (frequency) - linear (dB) scale.	

During the measurement it should be ensured that the measured signal is really the echo signal and not the comfort noise which possibly may be inserted in sending direction in order to mask the echo signal.

Measurement method:

See EN 300 176-2 [10].

7.5.5 Transmission characteristics for PP type 2a (P.311 tested, wideband handset)

The requirements defined in this clause are based on ITU-T Recommendation P.311 [20]. They complete or replace the corresponding parameters of P 311 Recommendation when necessary.

NOTE: When using Type 3.2 artificial ear, the Type 3.2 artificial ear with a high -grade leak is recommended.

7.5.5.1 Sending characteristics

7.5.5.1.1 Loudness rating

See ITU-T Recommendation P.311 [20], clause 4.1.

The tolerance for SLR shall be $\pm 3,5$ dB.

Measurement method:

See ITU-T Recommendation P.311 [20], clause A.4.1.

7.5.5.1.2 Sensitivity/frequency characteristics

See ITU-T Recommendation P.311 [20], clause 4.2.

Measurement method:

See ITU-T Recommendation P.311 [20], clause A.4.2.

7.5.5.1.3 Noise

See ITU-T Recommendation P.311 [20], clause 4.3.

The limit for sending noise shall be -64 dBm0(A).

Measurement method:

See ITU-T Recommendation P.311 [20], clause A.4.3.

7.5.5.1.4 Distortion

See ITU-T Recommendation P.311 [20], clause 4.4.

The measurement shall be done in the level range from -10 dB to +5 dB re ARL.

Measurement method:

See ITU-T Recommendation P.311 [20], clause A.4.4.

7.5.5.1.5 Discrimination against out-of-band input signals

See ITU-T Recommendation P.311 [20], clause 4.5.

Measurement method:

See ITU-T Recommendation P.311 [20], clause A.4.5.

7.5.5.2 Receiving characteristics

7.5.5.2.1 Loudness rating

See ITU-T Recommendation P.311 [20], clause 5.1.

The tolerance for RLR shall be $\pm 3,5$ dB.

Measurement method:

See ITU-T Recommendation P.311 [20], clause A.5.1.

7.5.5.2.2 Sensitivity/frequency characteristics

See ITU-T Recommendation P.311 [20], clause 5.2.

Measurement method:

See ITU-T Recommendation P.311 [20], clause A.5.2.

7.5.5.2.3 Noise

See ITU-T Recommendation P.311 [20], clause 5.3.

Measurement method:

See ITU-T Recommendation P.311 [20], clause A.5.3.

7.5.5.2.4 Distortion

See ITU-T Recommendation P.311 [20], clause 5.4.

The measurements shall be done in the level range from +5 dBm0 to -20 dBm0 and the limits shall be:

Table 7.41: Mask for signal to distortion ratio

Receiving Level at the digital interface (dBm0)	Signal-to-distortion ratio limit (dB)		
	200 Hz	1 kHz	6 kHz
+5	0	35,0	29,0
+0 to -10	29,0	35,0	29,0
-20	27,0	27	0

NOTE 1: Limits at intermediate frequencies lie on a straight line drawn between the given values on a linear (dB ratio) - logarithmic (frequency) scale.

NOTE 2: The value given here are the limits of the mask for distortion at a given receiving level.

Measurement method:

See ITU-T Recommendation P.311 [20], clause A.5.4.

7.5.5.2.5 Spurious out-of-band receiving signals

See ITU-T Recommendation P.311 [20], clause 5.5.

Measurement method:

See ITU-T Recommendation P.311 [20], clause A.5.5.

7.5.5.3 Sidetone characteristics

7.5.5.3.1 Talker sidetone

See ITU-T Recommendation P.311 [20], clause 6.1.

Measurement method:

See ITU-T Recommendation P.311 [20], clause A.6.1.

7.5.5.3.2 Sidetone distortion

See ITU-T Recommendation P.311 [20], clause 6.2.

Measurement method:

See ITU-T Recommendation P.311 [20], clause A.6.2.

7.5.5.4 Echo path loss characteristics

7.5.5.4.1 Weighted terminal coupling loss

The requirements of ITU-T Recommendation P.311 [20], clause 7.1 shall apply with the following difference:

- The limit for TCLw shall be at least 42 dB.

This value differs from P 311 requirement (35 dB) in order to ensure better compatibility with long delay networks.

Measurement method:

See ITU-T Recommendation P.311 [20], clause A.7.1.

7.5.5.4.2 Stability loss

See ITU-T Recommendation P.311 [20], clause 7.2.

Measurement method:

See ITU-T Recommendation P.311 [20], clause A.7.2.

7.5.6 Transmission characteristics for PP type 2b and 2c (HATS tested wideband handsets)

7.5.6.1 PP frequency responses

7.5.6.1.1 Sending

Requirement:

The send frequency response of the handset or the headset shall be within a mask as defined in table 7.42 and shown in figure 7.11. This mask shall be applicable for all types of handsets and headsets.

Table 7.42: Send frequency response

Frequency (Hz)	Upper Limit	Lower Limit
100	0	
200	5	-5
5 000	5	-5
6 300	5	-10
8 000	5	

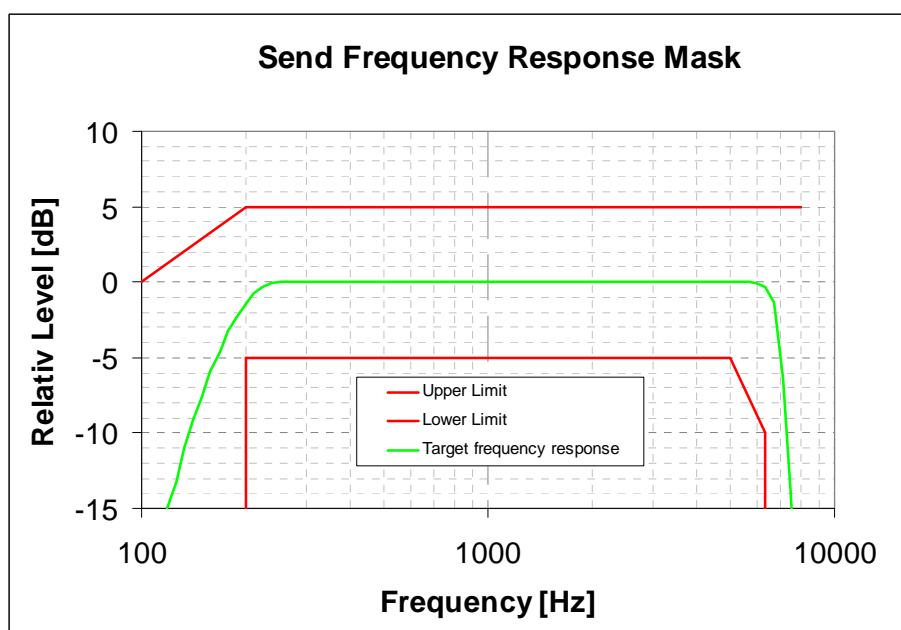

Figure 7.11: Send frequency response mask

NOTE 1: The basis for the target frequency responses in sending and receiving is the orthotelephonic reference response which is measured between 2 subjects in 1 m distance under free field conditions and is assuming an ideal receive characteristic. Under these conditions the overall frequency response shows a rising slope. In opposite to other standards the present document no longer uses the ERP as the reference point for receiving but the diffuse-field. With the concept of diffuse-field based receive measurements a rising slope for the overall frequency response is achieved by a flat target frequency response in sending and a diffuse-field based receiving frequency response.

NOTE 2: A "balanced" frequency response is preferable from the perception point of view. If frequency components in the low frequency domain are attenuated in a similar way frequency components in the high frequency domain should be attenuated.

The limit curves shall be determined by straight lines joining successive co-ordinates given in the table, where frequency response is plotted on a linear dB scale against frequency on a logarithmic scale. is a floating or "best fit" mask.

Measurement method:

See EN 300 176-2 [10].

7.5.6.1.2 Receiving

Requirement:

The receive frequency response of the handset or the headset shall be within a mask as defined in table 7.43 and shown in figures 7.12 and 7.13. The application force for handsets is 2N, 8N and 13N. This mask defined for 8 N and 13 N application forces shall be applicable for all types of headsets.

Table 7.43: Receive Frequency Response Mask

Frequency (Hz)	Upper Limit 8N applicable to standard and improved	Lower Limit 8N applicable to standard and improved	Upper Limit 13N applicable to standard and improved	Lower Limit 13N applicable to standard and improved	Upper Limit 2N applicable only to improved	Lower Limit 2N applicable only to improved
120	3		3		11	
200	3	-8	3	-8	11	-15
300	3	-3	3	-3	11	-11
400	3	-3	3	-3	11	-11
900	4,7	-3	5,5	-3	11	-11
1 200	5,7	-8	6,4	-8	11	-11
1 500	6,3	-8	7,1	-8	11	-11
1 600	6,4	-7,1	7,3	-7,1	11	-11
2 000	7	-4	8	-4	11	-9
3 000	7	-4	8	-4	11	-6
3 500	7	-4	8	-5,3	11	-6
4 250	7	-4	8	-7,1	11	-6
5 000	7	-6,7	8	-8,5	11	-6
6 300	7	-10,5	8	-10,5	11	
7 000	7		8			
8 000	7		8			

NOTE 1: The basis for the target frequency responses in sending and receiving is the orthotelephonic reference response which is measured between 2 subjects in 1 m distance under free field conditions and is assuming an ideal receive characteristic. Under these conditions the overall frequency response shows a rising slope. In opposite to other standards the present document no longer uses the ERP as the reference point for receiving but the diffuse-field. With the concept of diffuse-field based receive measurements a rising slope for the overall frequency response is achieved by a flat target frequency response in sending and a diffuse based receiving frequency response.

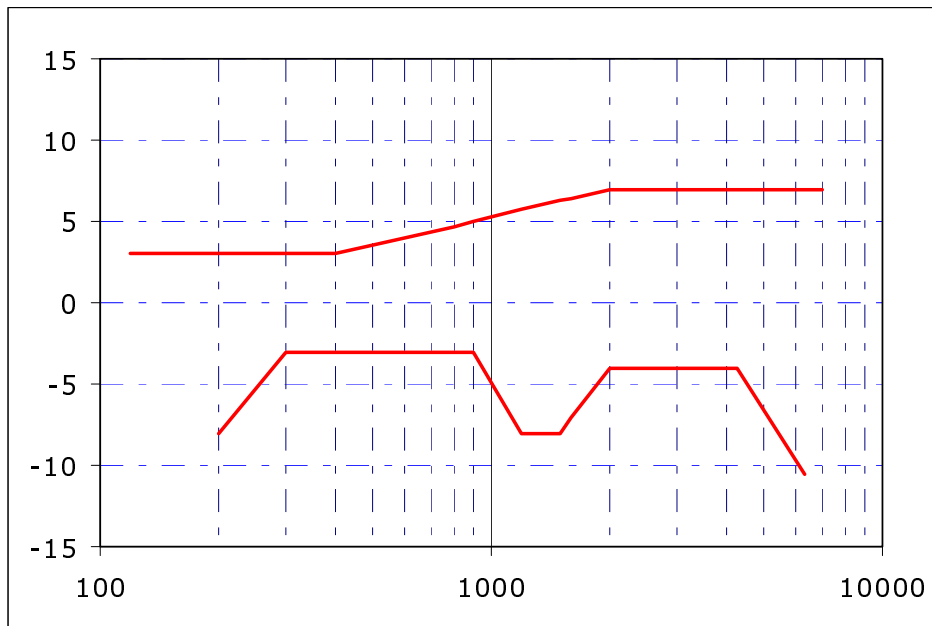

Figure 7.12: Receive frequency response mask for 8N application force

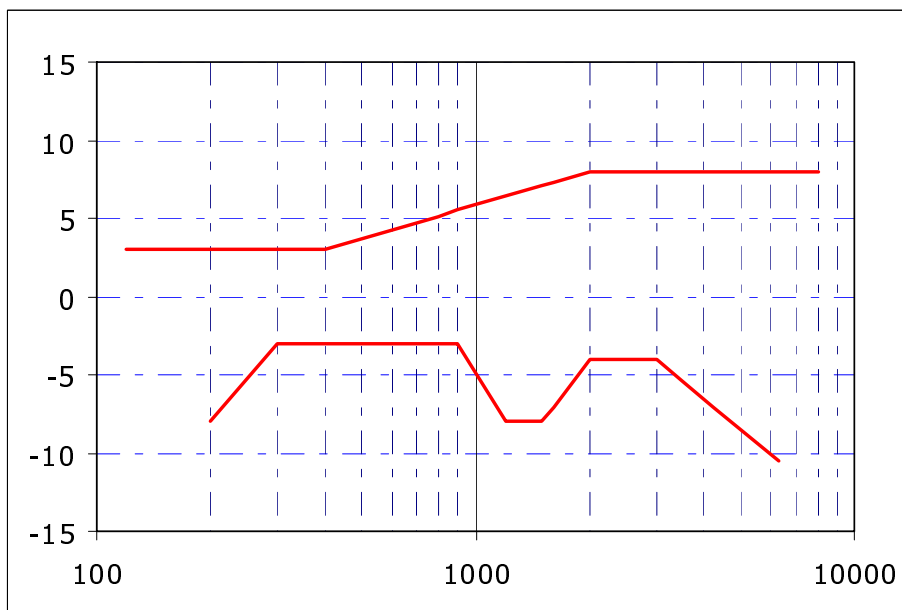

Figure 7.13: Receive frequency response mask for 13N application force

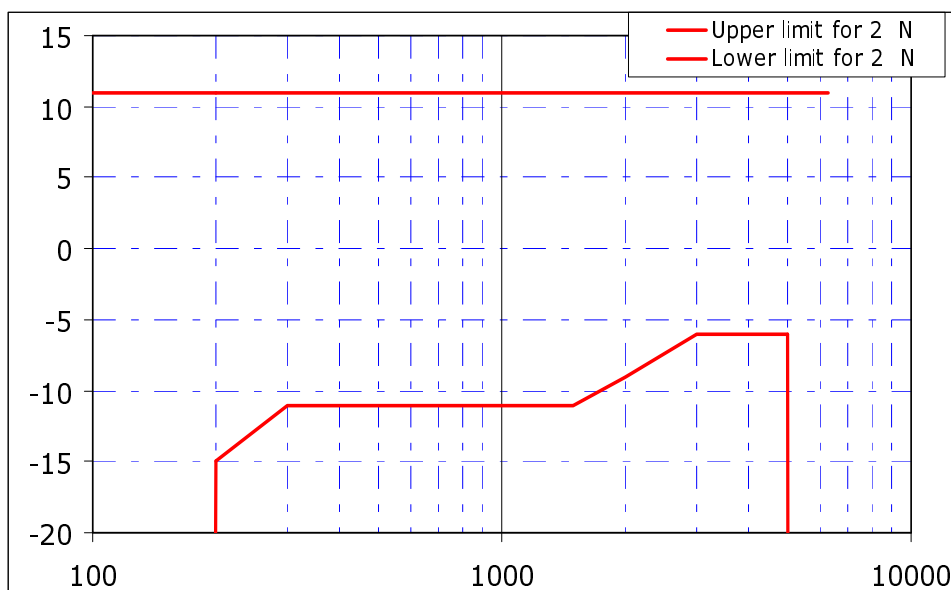

Figure 7.14: Receive frequency response mask for 2 N application force

NOTE 2: A "balanced" frequency response is preferable from the perception point of view. If frequency components in the low frequency domain are attenuated in a similar way frequency components in the high frequency domain should be attenuated.

The limit curves shall be determined by straight lines joining successive co-ordinates given in the table, where frequency response is plotted on a linear dB scale against frequency on a logarithmic scale. is a floating or "best fit" mask.

Measurement method:

See EN 300 176-2 [10].

7.5.6.2 PP send and receive loudness ratings

7.5.6.2.1 Nominal values

7.5.6.2.1.1 Send Loudness Rating

Requirement:

The nominal value of Send Loudness Rating (SLR) shall be:

$$\text{SLR}(\text{set}) = +8 \text{ dB} \pm 3 \text{ dB}.$$

Measurement method:

See EN 300 176-2 [10].

7.5.6.2.1.2 Receive Loudness Rating

Requirement:

The nominal value of Receive Loudness Rating (RLR) shall be:

$$\text{RLR}(\text{set}) = +2 \text{ dB} \pm 3 \text{ dB}.$$

RLR (binaural headset) = +8 dB \pm 3 dB for each earphone.

Measurement method:

See EN 300 176-2 [10].

7.5.6.2.2 User-controlled volume control in PP

Requirement:

A user-controlled volume control shall be provided in all PP equipment, except where an adaptive volume control is incorporated in the PP.

When adjusting the volume control from nominal setting (where RLR_H is closest to its nominal value) to maximum setting, the decrease in RLR_H shall be not less than 6 dB.

A user-controlled volume control can be implemented either as a receiving volume control (where RLR_H is changed) or as a "joint-acting" volume control (where SLR_H and RLR_H are simultaneously changed in opposite directions). For both types of volume control RLR_H and SLR_H shall simultaneously meet the values given in clause 7.2.1 (including the tolerances) for at least one setting of the volume control.

The RLR_H and SLR_H shall not exceed the limits given in tables 7.44 and 7.45.

Table 7.44: Absolute limits for "joint-acting" volume control

Volume setting	Maximum	Minimum
RLR_H	-13 dB	19 dB
SLR_H	17 dB	3 dB

Table 7.45: Absolute limits for a receiving volume control

Volume setting	Maximum	Minimum
RLR_H	-13 dB	19 dB

NOTE 1: Minimum setting: The setting where the RLR has its maximum value.
Maximum setting: The setting where the RLR has its minimum value.

NOTE 2: A user-controlled volume control should include an automatic reset function that ensures that the default setting for each new call is no louder than the nominal setting.

Measurement method:

See EN 300 176-2 [10].

7.5.6.2.3 PP adaptive volume control

Requirement:

The PP shall inform the FP if an adaptive volume control is implemented in the PP. Clause 7.7.41 in EN 300 175-5 [5] describes how this shall be done.

Measurement method:

See EN 300 176-2 [10].

7.5.6.3 Sidetone

7.5.6.3.1 Talker sidetone

Requirement:

The STMR shall be $+16 \text{ dB} \pm 4 \text{ dB}$ for nominal setting of the volume control.

For all other positions of the volume control, the STMR must not be below $+8 \text{ dB}$.

NOTE: It is preferable to have a constant STMR independent of the volume control setting.

Measurement method:

See EN 300 176-2 [10].

7.5.6.3.2 D Factor

Requirement:

The D Factor shall be:

D Factor \geq -5 dB.

For PPs with noise rejection capability as declared by the applicant:

D Factor \geq 2 dB.

NOTE 1: The noise rejection capability option is recommended for PPs used in noisy environments.

PPs with declared noise rejection capability option shall indicate this to the FP before or at call set-up by including this information in the <<TERMINAL CAPABILITY>> information element. See EN 300 175-5 [5], clause 7.7.41.

NOTE 2: It should be checked that noise rejection capability does not create impairments on speech signal.

Measurement method:

See EN 300 176-2 [10].

7.5.6.3.3 Sidetone delay

Requirement:

The maximum sidetone-round-trip delay shall be \leq 5 ms.

Measurement method:

See EN 300 176-2 [10].

7.5.6.4 Terminal coupling loss

7.5.6.4.1 Weighted Terminal Coupling Loss (TCLw)

Requirement:

The TCLw shall be \geq 55 dB.

With the volume control set to maximum TCLw shall be \geq 46 dB.

It is recommended to set back the volume control to nominal level at the establishment of each new call, if TCLw does not reach 55 dB at the selected volume control.

Measurement method:

See EN 300 176-2 [10].

7.5.6.4.2 Stability loss

Requirement:

With the handset lying on and the transducers facing a hard surface, the attenuation from the digital input to the digital output shall be at least 6 dB at all frequencies in the range of 100 Hz to 8 kHz. In case of headsets the requirement applies for the closest possible position between microphone and headset receiver.

NOTE: Depending on the type of headset it may be necessary to repeat the measurement in different positions.

Measurement method:

See EN 300 176-2 [10].

7.5.6.5 Distortion

7.5.6.5.1 Sending Distortion

Requirement:

The ratio of signal to harmonic distortion shall be above the following mask.

Table 7.46: Ratio of signal to harmonic distortion (sending)

Frequency	Ratio
315 Hz	26 dB
400 Hz	30 dB
1 kHz	30 dB
2 kHz	30 dB

Limits at intermediate frequencies lie on a straight line drawn between the given values on a linear (dB ratio) - logarithmic (frequency) scale.

Measurement method:

See EN 300 176-2 [10].

7.5.6.5.2 Receiving Distortion

Requirement:

The ratio of signal to harmonic distortion shall be above the following mask.

Table 7.47: Ratio of signal to harmonic distortion (receiving)

Frequency	Signal to distortion ratio limit, receiving
315 Hz	26 dB
400 Hz	30 dB
500 Hz	30 dB
800 Hz	30 dB
1 kHz	30 dB
2 kHz	30 dB

Limits at intermediate frequencies lie on a straight line drawn between the given values on a linear (dB ratio) - logarithmic (frequency) scale.

Measurement method:

See EN 300 176-2 [10].

7.5.6.6 Noise

7.5.6.6.1 Sending

Requirement:

The maximum noise level produced by the PP at the POI under silent conditions in the sending direction shall not exceed -68 dBm0(A).

No peaks in the frequency domain higher than 10 dB above the average noise spectrum shall occur.

Measurement method:

See EN 300 176-2 [10].

7.5.6.6.2 Receiving

Requirement:

Telephone sets with adjustable receive levels shall be adjusted so that the RLR is as close as possible to the nominal RLR.

The receive noise shall be less than -57 dBPa(A).

Where a volume control is provided, the measured noise shall not be greater than -54 dBPa(A) at the maximum setting of the volume control.

Measurement method:

See EN 300 176-2 [10].

7.5.6.7 Acoustic shock

In order to fulfil the acoustic shock requirements, it is recommended to follow the guidelines of ITU-T Recommendation P.360 [33]. If needed the PP may have to implement some kind of hardware limiter.

7.5.6.7.1 Continuous signal

Requirement:

With a digitally encoded signal representing the maximum possible signal level at the digital interface, the sound pressure level at the ERP shall not exceed 24 dBPa (rms unweighted).

Measurement method:

See EN 300 176-2 [10].

7.5.6.7.2 Peak signal

Requirement:

The receiving equipment shall limit the peak sound pressure at the ERP to less than 36 dBPa under any continuous or transient condition.

7.5.6.8 Delay

The sum of the delays from the MRP to the air interface and from the air interface to the ERP (round-trip delay) shall not exceed 20 ms.

Measurement method:

See EN 300 176-2 [10].

7.5.6.9 Variation of gain with input level-sending

Requirement:

The sensitivity determined with input sound pressure levels between -24,7 dBPa and 5,3 dBPa shall not differ by more than ± 2 dB from the sensitivity determined with an input sound pressure level of -4,7 dBPa. For the input sound pressure level of 5,3 dBPa a limit of +4/-2 dB applies.

Table 7.48: Variation of sending gain vs input level

Linearity range of SLR: $\Delta\text{SLR} = \text{SLR} - \text{SLR}@-4,7 \text{ dBPa}$			
Input Level in dBPa	Target ΔSLR	Upper limit (dB)	Lower limit (dB)
-24,7	0	2	-2
-19,7	0	2	-2
-14,7	0	2	-2
-9,7	0	2	-2
-4,9	0	2	-2
-4,7	0	0	0
-4,5	0	2	-2
0,3	0	2	-2
5,3	0	4	-4

Measurement method:

See EN 300 176-2 [10].

7.5.6.10 Double talk Performance

NOTE: Those parameters are optional, but are strongly recommended for improved class.

During double talk the speech is mainly determined by 2 parameters: impairment caused by echo during double talk and level variation between single and double talk (attenuation range).

In order to guarantee sufficient quality under double talk conditions the Talker Echo Loudness Rating should be high and the attenuation inserted should be as low as possible. Terminals which do not allow double talk in any case should provide a good echo attenuation which is realized by a high attenuation range in this case.

The most important parameters determining the speech quality during double talk are (see ITU-T Recommendations P.340 [22] and P.502 [27]):

- Attenuation range in sending direction during double talk $A_{H,S,dt}$.
- Attenuation range in receiving direction during double talk $A_{H,R,dt}$.
- Echo attenuation during double talk.

7.5.6.10.1 Attenuation Range in Sending Direction during Double Talk $A_{H,S,dt}$ **Requirement:**

Based on the level variation in sending direction during double talk $A_{H,S,dt}$ the behavior of the terminal can be classified according to table 7.49.

Table 7.49: Category regarding "duplex capability" depending on $A_{H,S,dt}$

Category (according to ITU-T P.340 [22])	1	2a	2b	2c	3
	Full Duplex Capability	Partial Duplex Capability			No Duplex Capability
$A_{H,S,dt}$ [dB]	≤ 3	≤ 6	≤ 9	≤ 12	> 12

In general this table provides a quality classification of terminals regarding double talk performance. However, this does not mean that a terminal which is category 1 based on the double talk performance is of high quality concerning the overall quality as well.

Measurement method:

See EN 300 176-2 [10].

7.5.6.10.2 Attenuation Range in Receiving Direction during Double Talk $A_{H,R,dt}$

Requirement:

Based on the level variation in receiving direction during double talk $A_{H,R,dt}$ the behavior of the terminal can be classified according to table 7.50.

Table 7.50: Category regarding "duplex capability" depending on $A_{H,R,dt}$

Category (according to ITU-T P.340 [22])	1	2a	2b	2c	3
	Full Duplex Capability	Partial Duplex Capability			No Duplex Capability
$A_{H,R,dt}$ [dB]	≤ 3	≤ 5	≤ 8	≤ 10	> 10

In general this table provides a quality classification of terminals regarding double talk performance. However, this does not mean that a terminal which is category 1 based on the double talk performance is of high quality concerning the overall quality as well.

Measurement method:

See EN 300 176-2 [10].

7.5.6.10.3 Detection of Echo Components during Double Talk

Requirement:

Echo Loss during double talk is the echo suppression provided by the terminal during double talk measured at the electrical reference point.

NOTE: The echo attenuation during double talk is based on the parameter Talker Echo Loudness Rating (TELRdt). It is assumed that the terminal at the opposite end of the connection provides nominal Loudness Rating (SLR + RLR = 10 dB).

Under these conditions the requirements given in the table below are applicable (more information can be found in annex A of the ITU-T Recommendation P.340 [22]).

Table 7.51: Category regarding "duplex capability" depending on Echo Loss

Category (according to ITU-T P.340 [22])	1	2a	2b	2c	3
	Full Duplex Capability	Partial Duplex Capability			No Duplex Capability
Echo Loss [dB]	≥ 27	≥ 23	≥ 17	≥ 11	< 11

Measurement method:

See EN 300 176-2 [10].

7.5.6.10.4 Minimum activation level and sensitivity of double talk detection

For further study.

7.5.6.11 Switching characteristics

NOTE 1: Those parameters are optional, but are strongly recommended for improved class.

NOTE 2: Additional requirements may be needed in order to further investigate the effect of NLP implementations on the users perception of speech quality.

7.5.6.11.1 Activation in Sending Direction

The activation in sending direction is mainly determined by the built-up time $T_{r,S,min}$ and the minimum activation level ($L_{S,min}$). The minimum activation level is the level required to remove the inserted attenuation in sending direction during idle mode. The built-up time is determined for the test signal burst which is applied with the minimum activation level.

The activation level described in the following is always referred to the test signal level at the mouth reference point (MRP).

Requirement:

The minimum activation level $L_{s,min}$ shall be ≤ -20 dBPa.

The built-up time $T_{r,S,min}$ (measured with minimum activation level) should be ≤ 15 ms.

Measurement method:

See EN 300 176-2 [10].

7.5.6.11.2 Activation in Receiving Direction

The activation in sending direction is mainly determined by the built-up time $T_{r,R,min}$ and the minimum activation level ($L_{R,min}$). The minimum activation level is the level required to remove the inserted attenuation in receiving direction during idle mode. The built-up time is determined for the test signal burst which is applied with the minimum activation level.

The activation level described in the following is always referred to the test signal level at the electrical reference point (POI).

Requirements:

The minimum activation level $L_{R,min}$ shall be $\leq -35,7$ dBm0 (measured during the active signal part).

The built-up time $T_{r,R,min}$ (measured with minimum activation level) shall be ≤ 15 ms.

Measurement method:

See EN 300 176-2 [10].

7.5.6.11.3 Silence Suppression and Comfort Noise Generation

For further study.

7.5.6.11.4 Performance in Sending in the Presence of Background Noise

Requirement:

The level of comfort noise shall be within in a range of +2 dB and -5 dB compared to the original (transmitted) background noise. The noise level is calculated with psophometric weighting.

NOTE 1: It is advisable that the comfort noise matches the original signal as good as possible (from a perceptual point of view).

NOTE 2: Input for further specification necessary (e.g. on temporal matching).

The spectral difference between comfort noise and original (transmitted) background noise shall be within the mask given through straight lines between the breaking points on a logarithmic (frequency) - linear (dB sensitivity) scale as given in table 7.52.

Table 7.52: Requirements for Spectral Adjustment of Comfort Noise (Mask)

Frequency (Hz)	Upper Limit	Lower Limit
200	12	-12
800	12	-12
800	10	-10
2 000	10	-10
2 000	6	-6
4 000	6	-6
8 000	6	-6

NOTE: All sensitivity values are expressed in dB on an arbitrary scale.

Measurement method:

See EN 300 176-2 [10].

7.5.6.11.5 Speech Quality in the Presence of Background Noise

For further study.

7.5.6.11.6 Quality of Background Noise Transmission (with Far End Speech)

Requirement:

The test is carried out applying the Composite Source Signal (CSS) in receiving direction. During and after the end of Composite Source Signal (CSS) bursts (representing the end of far end speech simulation) the signal level in sending direction should not vary more than 10 dB (during transition to transmission of background noise without far end speech). The measurement is conducted for all types of background noise as defined in the measurement method.

Measurement method:

See EN 300 176-2 [10].

7.5.6.11.7 Quality of background noise transmission (with Near End Speech)

Requirement:

The test is carried out applying a simulated speech signal in sending direction. During and after the end of the simulated speech signal (Composite Source Signal (CSS) bursts) the signal level in sending direction should not vary more than 10 dB.

Measurement method:

See EN 300 176-2 [10].

7.5.6.12 Quality of echo cancellation

NOTE: Those parameters are optional, but are strongly recommended for improved class.

7.5.6.12.1 Temporal echo effects

Requirement:

This test is intended to verify that the system will maintain sufficient echo attenuation during single talk. The measured echo attenuation during single talk should not decrease by more than 6 dB from the maximum measured during the TCLw test.

Measurement method:

See EN 300 176-2 [10].

7.5.6.12.2 Spectral Echo Attenuation

Requirement:

The echo attenuation vs. frequency shall be below the tolerance mask given in table 7.53.

Table 7.53: Spectral echo loss limits

Frequency (Hz)	Upper Limit
100	-20
200	-30
300	-38
800	-34
1 500	-33
2 600	-24
4 000	-24
8 000	-24

NOTE 1: All sensitivity values are expressed in dB on an arbitrary scale.
 NOTE 2: The limit at intermediate frequencies lies on a straight line drawn between the given values on a log (frequency) - linear (dB) scale.

During the measurement it should be ensured that the measured signal is really the echo signal and not the comfort noise which possibly may be inserted in sending direction in order to mask the echo signal.

Measurement method:

See EN 300 176-2 [10].

7.5.7 Transmission characteristics for PP types 4a and 4b (HATS Tested wideband loudspeaking and handsfree devices)

7.5.7.1 Sending sensitivity/frequency response

Requirement:

The sending sensitivity/frequency response shall be within the limits given in table 7.54.

Table 7.54: Sending frequency response

Frequency (Hz)	Upper limit (dB)	Lower limit (dB)
100	4	-∞
125	4	-10
200	4	-4
1 000	4	-4
5 000	(note)	-4
6 300	9	-7
8 000	9	-∞

NOTE: The limits for intermediate frequencies lie on a straight line drawn between the given values on a linear (dB) - logarithmic (Hz) scale.

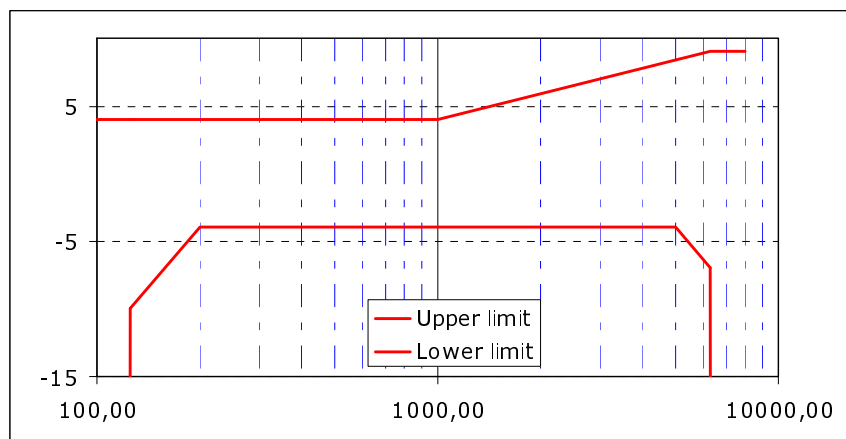

Figure 7.15: Sending sensitivity/frequency mask for HFT

NOTE 1: Level at 125 Hz can be reduced (low limit at -10 dB), it can be useful for reduction of transmitted noise and obtaining a more well balanced response curve relative to high frequencies (see note 2).

NOTE 2: A "well balanced" frequency response is preferable from the perception point of view. If frequency components in the low frequency domain are attenuated in a similar way frequency components in the high frequency domain should be attenuated.

Measurement method:

See EN 300 176-2 [10].

7.5.7.2 Receive sensitivity/frequency response

Requirement:

The following masks are required for handsfree and loudspeaking terminals. The mask is drawn as straight lines between the breaking points in the table on a logarithmic (frequency) - linear (dB sensitivity) scale.

Desktop operated PP

Table 7.55: Receiving frequency response desktop handsfree PP

Frequency (Hz)	Upper limit (dB)	Lower limit (dB)
100	8	-
125	8	-
160	8	-
200	8	-∞
200	8	-12
250	8	-9
315	7	-6
400	6	-6
500	6	-6
630	6	-6
800	6	-6
1 000	6	-6
1 300	6	-6
1 600	6	-6
2 000	6	-6
2 500	6	-6
3 100	6	-6
4 000	6	-6
5 000	6	-6
6 300	6	-9
6 300	6	-∞
7 000	6	-
8 000	6	-

NOTE 1: Referring to I-ETS 300 245-6 [i.12], lower limit has been modified: no requirement at 160 Hz, -12 dB at 200 Hz and -9 dB at 250 Hz instead of -15 dB, -9 dB and -6 dB. This results in a better balanced response curve and avoids necessity in most case to introduce "bass boost" for amplification.

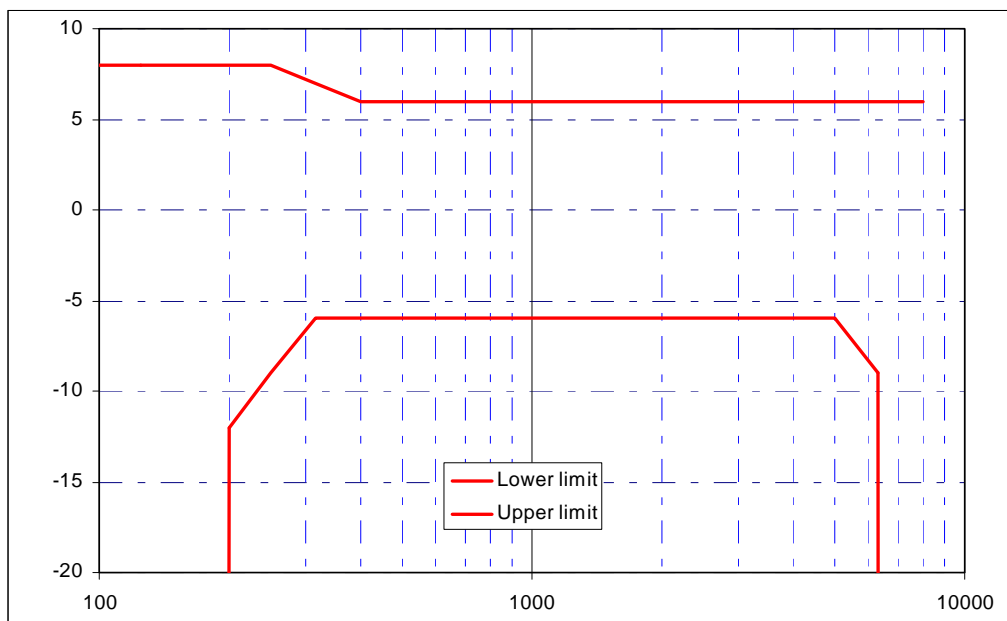

Figure 7.16: Receiving sensitivity/frequency mask for Desktop handsfree PP

Handheld operated PP

Improved class

Table 7.56: Receiving frequency response handheld handsfree PP improved

Frequency (Hz)	Upper limit (dB)	Lower limit (dB)
100	6	-
200	6	-
250	6	-
315	6	-∞
315	6	-12
400	6	-6
500	6	-6
630	6	-6
800	6	-6
1 000	6	-6
1 300	6	-6
1 600	6	-6
2 000	6	-6
2 500	6	-6
3 100	6	-6
4 000	6	-6
5 000	6	-9
6 300	6	-12
6 300	6	-∞
7 000	6	-
8 000	6	-

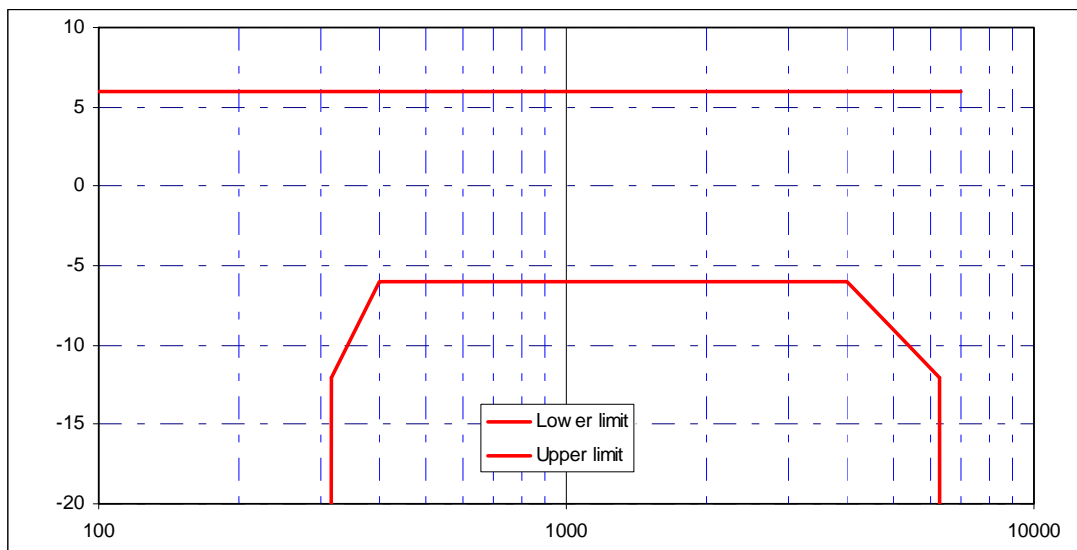

Figure 7.17: Receiving sensitivity/frequency mask for improved handheld PP

NOTE 2: At high frequencies, lower limit is relaxed. It is necessary to take into account that in most case measurement will be made facing to the opposite side of output of loudspeaker.

standard class

Table 7.57: Receiving frequency response handheld handsfree PP standard

Frequency (Hz)	Upper limit (dB)	Lower limit (dB)
100	6	-
200	6	-
250	6	-
315	6	-
400	6	-∞
400	6	-12
500	6	-6
630	6	-6
800	6	-6
1 000	6	-6
1 300	6	-6
1 600	6	-6
2 000	6	-6
2 500	6	-6
3 100	6	-6
4 000	6	-6
5 000	6	-9
6 300	6	-12
6 300	6	-∞
7 000	6	-
8 000	6	-

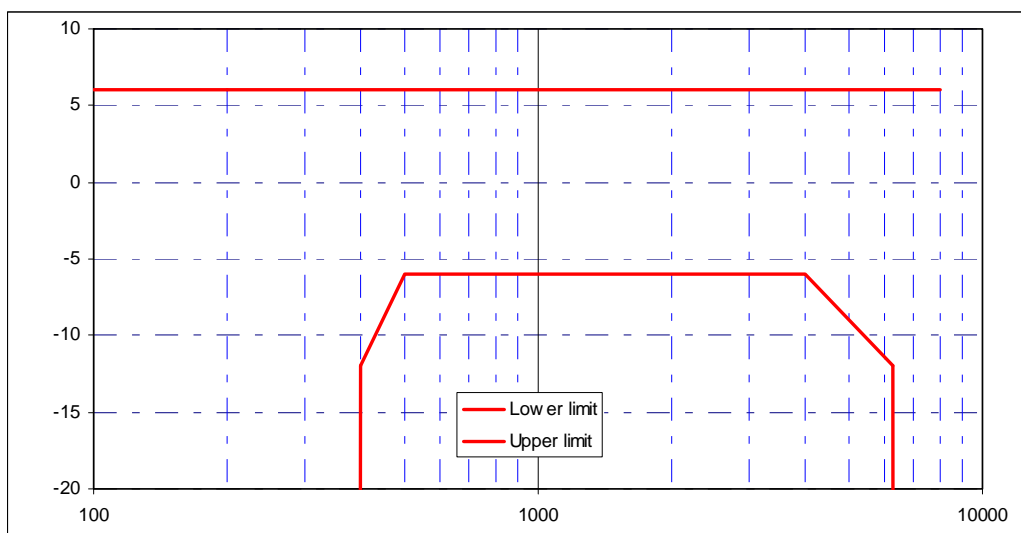

Figure 7.18: Receiving sensitivity/frequency mask for standard hand-held PP

NOTE 3: At high frequencies, lower limit is relaxed. It is necessary to take into account that in most case measurement will be made facing to the opposite side of output of loudspeaker.

Measurement method:

See EN 300 176-2 [10].

7.5.7.3 Sending loudness rating

Requirement:

The value of SLR shall be $+13 \text{ dB} \pm 3 \text{ dB}$.

This value is derived from Handset SLR. According to ITU-T Recommendation P.340 [22] the SLR of a hands-free telephone should be about 5 dB higher than the SLR of the corresponding handset telephone.

This value will be identical for all type of terminal (desktop, handheld, etc.) difference in efficiency will be given by conditions for measurement.

Measurement method:

See EN 300 176-2 [10].

7.5.7.4 Receive loudness rating

Requirement:

Desktop operated PP

Nominal value of RLR = $+5 \pm 3 \text{ dB}$. This value has to be fulfilled for one position of volume range.

Value of RLR at upper part of volume range must be less than (louder) or equal to -2 dB: $\text{RLR max} \leq -2 \text{ dB}$.

Range of volume control must be equal or exceed 15 dB: $(\text{RLR min} - \text{RLRmax}) \geq 15 \text{ dB}$.

Handheld operated PP

Improved class

Nominal value of RLR = $+9 \pm 3 \text{ dB}$. This value has to be fulfilled for one position of volume range.

Value of RLR at upper part of volume range must be less than (louder) or equal to 4 dB: $\text{RLR max} \leq +4 \text{ dB}$.

Recommended value is $\text{RLR max} \leq +2 \text{ dB}$.

Range of volume control must be equal or exceed 15 dB: $(\text{RLR min} - \text{RLRmax}) \geq 15 \text{ dB}$.

Standard class

Nominal value of RLR = $+9 \pm 3$ dB. This value has to be fulfilled for one position of volume range.

Value of RLR at upper part of volume range must be less than (louder) or equal to 8 dB: $\text{RLR max} \leq +8$ dB.

Recommended value is $\text{RLR max} \leq +6$ dB.

Range of volume control must be equal or exceed 15 dB: $(\text{RLR min} - \text{RLRmax}) \geq 15$ dB.

Measurement method:

See EN 300 176-2 [10].

7.5.7.5 Sending distortion**Requirement:**

The ratio of signal to harmonic distortion shall be above the following mask.

Table 7.58: Ratio of signal to harmonic distortion (sending)

Frequency	Ratio
200 Hz	25 dB
315 Hz	26 dB
400 Hz	30 dB
1 kHz	30 dB
3 kHz	30 dB

Limits at intermediate frequencies lie on a straight line drawn between the given values on a linear (dB ratio) - logarithmic (frequency) scale.

Measurement method:

See EN 300 176-2 [10].

7.5.7.6 Receiving distortion**Requirement:****Desktop and Handheld terminals**

The ratio of signal to harmonic distortion shall be above the following mask.

Table 7.59: Ratio of signal to harmonic distortion (receiving)

Frequency	Signal to distortion ratio limit, receiving for desktop terminal (dB)	Signal to distortion ratio limit, receiving for improved handheld terminal (dB)	Signal to distortion ratio limit, receiving for standard handheld terminal (dB)	Signal to distortion ratio limit, receiving for all terminals at maximum volume (dB)
315 Hz	26 dB			
400 Hz	30 dB			
500 Hz	30 dB	30 dB		
800 Hz	30 dB	30 dB	30 dB	20 dB
1 kHz	30 dB	30 dB	30 dB	
2 kHz	30 dB	30 dB	30 dB	
3 kHz	30 dB	30 dB	30 dB	
6 kHz	29 dB	29 dB	29 dB	

Limits at intermediate frequencies lie on a straight line drawn between the given values on a linear (dB ratio) - logarithmic (frequency) scale.

Measurement method:

See EN 300 176-2 [10].

7.5.7.7 Out-of-band signals in sending direction

Requirement:

Any spurious out-of-band image signals in the frequency range from 9 kHz to 16 kHz measured selectively shall be lower than the in-band level measured with a reference signal. The minimum level difference between the reference signal level and the out-of-band image signal level shall be as given in table 7.60.

Table 7.60: Out-of-band signals (sending)

Frequency	Signal limit
9 kHz	50 dB
16 kHz	60 dB
NOTE: The limits for intermediate frequencies lie on a straight line drawn between the given values on a linear (dB) - logarithmic (kHz) scale.	

Measurement method:

See EN 300 176-2 [10].

7.5.7.8 Out-of-band signals in receiving direction

Requirement:

Any spurious out-of-band image signals in the frequency range from 9 kHz to 16 kHz measured selectively shall be lower than the in-band level measured with a reference signal. The minimum level difference between the reference signal level and the out-of-band image signal level shall be as given in table 7.61.

Table 7.61: Out-of-band signals (receiving)

Frequency (kHz)	Signal limit (dB)
9	50
16	60
NOTE: The limits for intermediate frequencies lie on a straight line drawn between the given values on a linear (dB) - logarithmic (kHz) scale.	

Measurement method:

See EN 300 176-2 [10].

7.5.7.9 Sending noise

Requirement:

The limit for the maximum sending noise level shall be -64 dBm0(A).

No peaks in the frequency domain higher than 10 dB above the average noise spectrum shall occur.

Measurement method:

See EN 300 176-2 [10].

7.5.7.10 Receiving noise

Requirement:

A-weighted

The noise level shall not exceed -54 dBPa(A) at **nominal setting of the volume control**.

Octave band spectrum

The level in any 1/3-octave band, between 100 Hz and 10 kHz shall not exceed a value of -64 dBPa.

NOTE: No peaks in the frequency domain higher than 10 dB above the average noise spectrum should occur.

Measurement method:

See EN 300 176-2 [10].

7.5.7.11 Terminal Coupling Loss

Requirement:

Improved class

In order to meet the G.131 [30] talker echo objective requirements, the recommended weighted terminal coupling loss during single talk (TCL_{wst}) should be greater than 55 dB when measured under free field conditions. at **nominal setting of the volume control**.

A TCL_w greater than 46 dB is considered as acceptable.

For terminals fitted with a volume control the TCL_{wst} shall be not less than 40 dB for the higher gain settings above the nominal setting of the volume control.

Standard class

TCL_w shall be greater than 40 dB when measured under free field conditions at nominal setting of volume control.

TCL_{wst} shall be not less than 34 dB for the higher gain settings above the nominal setting of the volume control.

Measurement method:

See EN 300 176-2 [10].

7.5.7.12 Stability Loss

Requirement

For the calculation the averaged measured echo level at each frequency band is referred to the averaged test signal level measured in each frequency band. It must not exceed 6 dB for all frequencies and for all settings of volume control.

Measurement method:

See EN 300 176-2 [10].

7.5.7.13 Double Talk Performance

NOTE: When those parameters are optional, they are strongly recommended for improved class.

During double talk the speech is mainly determined by 2 parameters: impairment caused by echo during double talk and level variation between single and double talk (attenuation range).

In order to guarantee sufficient quality under double talk conditions the Talker Echo Loudness Rating should be high and the attenuation inserted should be as low as possible. Terminals which do not allow double talk in any case should provide a good echo attenuation which is realized by a high attenuation range in this case.

The most important parameters determining the speech quality during double talk are (see ITU-T Recommendations P.340 [22] and P.502 [27]):

- Attenuation range in sending direction during double talk $A_{H,S,dt}$.
- Attenuation range in receiving direction during double talk $A_{H,R,dt}$.
- Echo attenuation during double talk.

7.5.7.13.1 Attenuation Range in Sending Direction during Double Talk $A_{H,S,dt}$

Requirement:

Based on the level variation in sending direction during double talk $A_{H,S,dt}$ the behavior of the terminal can be classified according to table 7.62.

Table 7.62: Category regarding "duplex capability" depending on $A_{H,S,dt}$

Category (according to ITU-T P.340 [22])	1	2a	2b	2c	3
	Full Duplex Capability	Partial Duplex Capability			No Duplex Capability
$A_{H,S,dt}$ [dB]	≤ 3	≤ 6	≤ 9	≤ 12	> 12

In general this table provides a quality classification of terminals regarding double talk performance. However, this does not mean that a terminal which is category 1 or 2 based on the double talk performance is of high quality concerning the overall quality as well.

Improved PP has to be in a category between 1 and 2.

Measurement method:

See EN 300 176-2 [10].

7.5.7.13.2 Attenuation Range in Receiving Direction during Double Talk $A_{H,R,dt}$

Requirement:

Based on the level variation in receiving direction during double talk $A_{H,R,dt}$ the behavior of the terminal can be classified according to table 7.63.

Table 7.63: Category regarding "duplex capability" depending on $A_{H,R,dt}$

Category (according to ITU-T P.340 [22])	1	2a	2b	2c	3
	Full Duplex Capability	Partial Duplex Capability			No Duplex Capability
$A_{H,R,dt}$ [dB]	≤ 3	≤ 5	≤ 8	≤ 10	> 10

In general this table provides a quality classification of terminals regarding double talk performance. However, this does not mean that a terminal which is category 1 or 2 based on the double talk performance is of high quality concerning the overall quality as well.

Improved PP has to be in a category between 1 and 2.

Measurement method:

See EN 300 176-2 [10].

7.5.7.13.3 Detection of Echo Components during Double Talk

Requirement:

"Echo Loss" is the echo suppression provided by the terminal measured at the electrical reference point. Under these conditions the requirements given in the table below are applicable (more information can be found in annex A of the ITU-T Recommendation P.340 [22]).

Table 7.64: Category regarding "duplex capability" depending on Echo Loss

Category (according to ITU-T P.340 [22])	1	2a	2b	2c	3
	Full Duplex Capability	Partial Duplex Capability			No Duplex Capability
Echo Loss [dB]	≥ 27	≥ 23	≥ 17	≥ 11	< 11

NOTE: The echo attenuation during double talk is based on the parameter Talker Echo Loudness Rating ($TELR_{dt}$). It is assumed that the terminal at the opposite end of the connection provides nominal Loudness Rating ($SLR + RLR = 10$ dB).

Measurement method:

See EN 300 176-2 [10].

7.5.7.13.4 Minimum activation level and sensitivity of double talk detection

For further study.

7.5.7.14 Switching characteristics

NOTE 1: When those parameters are optional, they are strongly recommended for improved class.

NOTE 2: Additional requirements may be needed in order to further investigate the effect of NLP implementations on the users perception of speech quality.

7.5.7.14.1 Activation in Sending Direction

The activation in sending direction is mainly determined by the built-up time $T_{r,S,min}$ and the minimum activation level ($L_{S,min}$). The minimum activation level is the level required to remove the inserted attenuation in sending direction during idle mode. The built-up time is determined for the test signal burst which is applied with the minimum activation level.

The activation level described in the following is always referred to the test signal level at the mouth reference point (MRP).

Requirement:

The minimum activation level $L_{s,min}$ shall be ≤ -20 dBPa.

The built-up time $T_{r,S,min}$ (measured with minimum activation level) should be ≤ 15 ms.

Measurement method:

See EN 300 176-2 [10].

7.5.7.14.2 Activation in Receiving Direction

The activation in receiving direction is mainly determined by the built-up time $T_{r,R,min}$ and the minimum activation level ($L_{R,min}$). The minimum activation level is the level required to remove the inserted attenuation in receiving direction during idle mode. The built-up time is determined for the test signal burst which is applied with the minimum activation level.

The activation level described in the following is always referred to the test signal level at the electrical reference point (POI).

Requirements:

The minimum activation level $L_{R,min}$ shall be $\leq -35,7$ dBm0 (measured during the active signal part).

The built-up time $T_{r,R,min}$ (measured with minimum activation level) shall be ≤ 15 ms.

Measurement method:

See EN 300 176-2 [10].

7.5.7.14.3 Silence Suppression and Comfort Noise Generation

For further study.

7.5.7.14.4 Performance in sending direction in the presence of background noise

Requirement:

The level of comfort noise, if implemented, shall be within a range of +2 dB and -5 dB compared to the original (transmitted) background noise. The noise level is calculated with psophometric weighting.

NOTE 1: It is advisable that the comfort noise matches the original signal as good as possible (from a perceptual point of view).

NOTE 2: Input for further specification necessary (e.g. on temporal matching).

The spectral difference between comfort noise and original (transmitted) background noise shall be within the mask given through straight lines between the breaking points on a logarithmic (frequency) - linear (dB sensitivity) scale as given in table 7.65.

Table 7.65: Mask for requirements for Spectral Adjustment of Comfort Noise

Frequency (Hz)	Upper Limit	Lower Limit
200	12	-12
800	12	-12
800	10	-10
2 000	10	-10
2 000	6	-6
4 000	6	-6
8 000	6	-6

NOTE: All sensitivity values are expressed in dB on an arbitrary scale.

Measurement method:

See EN 300 176-2 [10].

7.5.7.14.5 Speech Quality in the Presence of Background Noise

For further study.

7.5.7.14.6 Quality of Background Noise Transmission (with Far End Speech)

Requirement:

The test is carried out applying the Composite Source Signal (CSS) in receiving direction. During and after the end of Composite Source Signal (CSS) bursts (representing the end of far end speech simulation) the signal level in sending direction should not vary more than 10 dB (during transition to transmission of background noise without far end speech). The measurement is conducted for all types of background noise as defined in EN 300 176-2 [10].

Measurement method:

See EN 300 176-2 [10].

7.5.7.14.7 Quality of background noise transmission (with Near End Speech)

Requirement:

The test is carried out applying a simulated speech signal in sending direction. During and after the end of the simulated speech signal (Composite Source Signal bursts) the signal level in sending direction should not vary more than 10 dB.

Measurement method:

See EN 300 176-2 [10].

7.5.7.15 Quality of echo cancellation

7.5.7.15.1 Temporal echo effects

Requirement:

This test is intended to verify that the system will maintain sufficient echo attenuation during single talk. The measured echo attenuation during single talk should not decrease by more than 6 dB from the maximum measured during the TCLw test.

Measurement method:

See EN 300 176-2 [10].

7.5.7.15.2 Spectral Echo Attenuation

Requirement:

The echo attenuation vs. frequency shall be below the tolerance mask given in table 7.66.

Table 7.66: Spectral echo loss limits

Frequency (Hz)	Upper Limit
100	-20
200	-30
300	-38
800	-34
1 500	-33
2 600	-24
4 000	-24
8 000	-24

NOTE 1: All sensitivity values are expressed in dB on an arbitrary scale.
 NOTE 2: The limit at intermediate frequencies lies on a straight line drawn between the given values on a log (frequency) - linear (dB) scale.

During the measurement it should be ensured that the measured signal is really the echo signal and not the comfort noise which possibly may be inserted in sending direction in order to mask the echo signal.

Measurement method:

See EN 300 176-2 [10].

7.6 Transmission characteristics for Fixed Parts

7.6.1 Transmission characteristics for FP type 1a ("Classic" Fixed Part with ISDN Network interface, 3,1 kHz service)

7.6.1.1 Reduction of echo from PP

The FP echo control functions described below shall be connected or disabled depending on a message from the PP or depending on call routing information and on type of service. It is recommended to disable them when it is known that the one-way delay of the connection is less than 25 ms excluding the DECT delay (e.g. internal Private Automatic Branch eXchange (PABX) connections). They may be disabled if the PP has $TCLw \geq 46$ dB.

A FP with a 4-wire interface (analog or digital) shall meet at least one of the two following requirements:

- a) artificial echo loss:
 - an artificial echo path shall be implemented into the FP between the line input and the line output, as shown in figure 7.19. The loss of that echo path shall be $24 \text{ dB} \pm 2 \text{ dB}$.

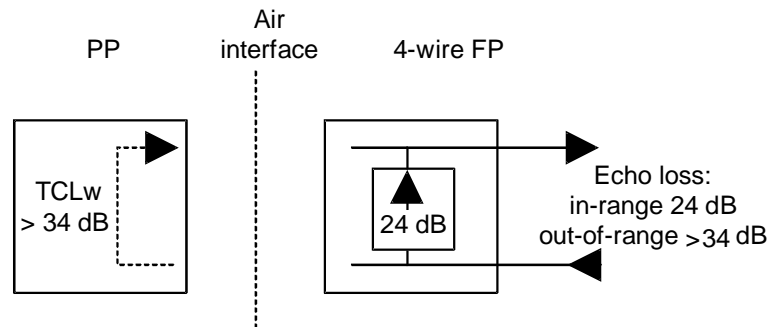

NOTE: The artificial echo simulates the echo from a very good analog 2-wire telephone. When a public network operator uses an echo canceller in the network (for a connection with long delay e.g. for a satellite link), the artificial echo loss path provides an in-range echo to ensure that the echo canceller and its Non-Linear Processor (NLP) is active. The NLP cancels the 34 dB DECT handset echo. See clause A.2.1. In some countries the echo cancellers in the public network do not depend on the artificial echo path to activate the NLP. Installations in such countries could have the artificial echo path permanently disabled.

Figure 7.19: Artificial echo path in a 4-wire FP

b) echo control device:

- an echo control device shall be implemented into the FP. The weighted Terminal Coupling Loss (TCLw) of the DECT system, defined from the FP line input to the FP line output, shall be at least 46 dB.

NOTE 1: Option a) is the option normally used for connections to the PSTN/ISDN. Option b) is needed, e.g. for tandem connection with GSM, clauses 8.2.1 and 8.3.2. Clause A.1.2 provides, for guidance and illustration, the description of a NLP implementation of option b). The control range for an echo canceller and hangover time for an NLP should be greater than or equal to 40 ms. A soft suppressor implementation is not recommended.

NOTE 2: The connect/disable function for options a) and b) is required for approval testing under EN 300 176-1 [9] and EN 300 176-2 [10]. Messages from the PP with control information are defined in EN 300 175-5 [5].

Measurement method:

See EN 300 176-2 [10].

7.6.1.2 FP Network echo control

In the most of the cases, there is no need for such an implementation (e.g. connections within a PABX, or a 4-wire connection via the PSTN/ISDN to an ISDN terminal).

However in some exceptional case FP Network echo control is implemented. In such a case the following requirements shall apply:

Requirement:

The network echo shall be controlled by inserting into the receiving speech path of the FP an echo loss meeting an extra echo loss ≥ 9 dB.

NOTE: The connect/disable function is required for approval testing (see EN 300 176-2 [10]). Messages from the PP with control information are defined in EN 300 175-5 [5], clause 7.7.16.

Measurement method:

See EN 300 176-2 [10].

7.6.1.3 FP adaptive volume control

Requirement:

An adaptive volume control, depending on the level of environmental noise at the PP, may be implemented into the FP. The gain variation shall be symmetrical, i.e. the increase in the receiving direction shall be equal to the decrease in the sending direction.

If the PP adaptive volume control feature is implemented then the FP adaptive volume control feature shall be disabled.

See annex D for further information.

Measurement method:

See EN 300 176-2 [10].

7.6.1.4 FP Delay

Requirement:

The sum of the delays from the digital line interface to the air interface and from the air interface to the digital line interface (round-trip delay) shall not exceed 20 ms. This value includes the 5 ms delay of the reference PP looping back the ADPCM digital signal towards the FP.

Measurement method:

See EN 300 176-2 [10].

7.6.2 Transmission characteristics for FP type 1b ("new" Fixed Part with ISDN Network interface, 3,1 kHz service)

NOTE: This clause is also applicable for FP type 4.

7.6.2.1 FP Network echo control

In the most of the cases, there is no need for such an implementation (e.g. connections within a PABX, or a 4-wire connection via the PSTN/ISDN to an ISDN terminal).

However in some exceptional cases FP Network echo control is implemented. In such a case the following requirements shall apply:

Requirement:

The network echo shall be controlled by inserting into the receiving speech path of the FP an echo control device inserting an extra echo loss ≥ 9 dB.

NOTE: The connect/disable function is required for approval testing (see EN 300 176-1[9] and EN 300 176-2 [10]). Messages from the PP with control information are defined in EN 300 175-5 [5], clause 7.7.16.

Measurement method:

See EN 300 176-2 [10].

7.6.2.2 FP adaptive volume control

Requirement:

An adaptive volume control, depending on the level of environmental noise at the PP, may be implemented into the FP. The gain variation shall be symmetrical, i.e. the increase in the receiving direction shall be equal to the decrease in the sending direction.

If the PP adaptive volume control feature is implemented then the FP adaptive volume control feature shall be disabled.

See annex D for further information.

Measurement method:

See EN 300 176-2 [10].

7.6.2.3 FP Delay

Requirement:

The sum of the delays from the digital line interface to the air interface and from the air interface to the digital line interface (round-trip delay) shall not exceed 20 ms. This value includes the 5 ms delay of the reference PP looping back the ADPCM digital signal towards the FP.

Measurement method:

See EN 300 176-2 [10].

7.6.3 Transmission characteristics for FP type 2 (Fixed Part with analog 2-wire interface, 3,1 kHz service)

7.6.3.1 FP adaptive volume control

Requirement:

An adaptive volume control, depending on the level of environmental noise at the PP, may be implemented into the FP. The gain variation shall be symmetrical, i.e. the increase in the receiving direction shall be equal to the decrease in the sending direction.

If the PP adaptive volume control feature is implemented then the FP adaptive volume control feature shall be disabled.

NOTE: For an FP with an analog interface, problems of saturation may occur depending on national RLR values.

See annex D for further information.

Measurement method:

See EN 300 176-2 [10].

7.6.3.2 Network echo control

Requirement:

The network echo shall be controlled by inserting into the receiving speech path of the FP an echo loss meeting the requirements as defined in table 7.67.

Table 7.67: Network echo control requirements

Echo path delay (2-way)		
Requirement 1: 0 ms to 4 ms	TELR	≥ 24 dB
Requirement 2: 0 ms to 60 ms	Extra echo loss	≥ 9 dB

Requirement 1 applies only to FP with an analog 2-wire line interface. Requirement 2 applies for both 2-wire and 4-wire line interfaces. If the echo control device in the FP contains a soft suppressor, it is recommended to not suppress more than 12 dB.

The 24 dB TELR limit applies for a PP with nominal values for SLR_H and RLR_H ($SLR_H = 8$ dB, $RLR_H = 2$ dB) and it corresponds to $LL_e = 24 - 8 - 2 = 14$ dB at the uniform PCM reference point of the FP. This requirement shall be met when the FP is terminated with the three terminating impedances, a, b and c, defined in TBR 038 [29], clause A.2.3. No recommendation is made for any particular implementation of the echo control device. For guidance and illustration, a reference soft suppressor that meets requirement 2 is described in clause A.3.1, and a reference echo canceller that meets requirement 1, is described in clause A.3.2.

Depending on routing information and on type of service, it shall be possible to connect and disable each of the echo control functions which perform the respective requirements 1 and 2.

The echo device implemented to meet requirement 2 may be disabled, or its loss may be reduced, in accordance with optionally available routing information, e.g. connections within a PABX, or a 4-wire connection via the PSTN/ISDN to an ISDN terminal.

NOTE: The connect/disable function for requirements 1 and 2 is required for approval testing (see EN 300 176-1[9] and EN 300 176-2 [10]). Messages from the PP with control information are defined in EN 300 175-5 [5], clause 7.7.16.

Measurement method:

See EN 300 176-2 [10].

7.6.3.3 Additional requirements for DECT FP provided with a 2-wire PSTN interface

These additional requirements and test methods are based on TBR 038 [29] with necessary deviations justified the following:

- any additional provision to meet these additional requirements shall be accommodated within the FP;
- mandatory tests already performed at the 4-wire uniform PCM reference point interface;
- requirements justified by the basic principles of the DECT standard including the digital radio link, the additional delay introduced and the use of small light weight portable handsets.

The tests shall be carried out on the EUT FP in conjunction with a reference PP, RePP, meeting the applicable speech performance characteristics. The RePP shall have nominal values of SLR_H and RLR_H ($SLR_H = 8$ dB, $RLR_H = 2$ dB), or else, the acceptance criteria of the requirements below shall be adjusted according to the deviations from nominal values. RePP has to support audio feature 1a or 1b.

7.6.3.3.1 General

7.6.3.3.1.1 Polarity independence

The requirements and associated test methods of clause 4.1.1 of TBR 038 [29] shall apply.

7.6.3.3.1.2 Feed Conditions

The requirements and associated test methods of clause 4.1.2 of TBR 038 [29] shall apply.

7.6.3.3.1.3 Power supply

The requirements and associated test methods of clause 4.1.3 of TBR 038 [29] shall apply.

7.6.3.3.2 Speech performance characteristics

The test laboratory shall perform the tests in such a way, that the results are not affected by the delay in the DECT radio interface, or by improper activation of the DECT echo control functions. The DECT echo control functions may be disabled during the tests.

7.6.3.3.2.1 Sensitivity/frequency response

Requirements:

The sensitivity masks from clause 7.5.1.1 shall be used.

Test method:

The test methods of clause 4.2.1 of TBR 038 [29] shall apply.

7.6.3.3.2.2 Sending and Receiving Loudness Ratings (SLR and RLR)

The requirements and associated test methods of clause 4.2.2 of TBR 038 [29] shall apply, except that the RLR acceptance criteria shall be -8 dB +/-4 dB for feeding resistance R_f set to 2 800 Ω , 1 000 Ω and 500 Ω .

NOTE: The basic DECT requirements (echo control, signal levels for A/D converters, etc.) are optimized for digital (ISDN) transmission characteristics. Analog transmissions over a modern network (from equipment using TBR 038 [29] values of SLR and RLR) often provide higher receive levels than a digital (ISDN) connection would. Therefore, noting that DECT PPs have a volume control with at least 6 dB gain, it should be allowed to design DECT FP equipment with a receive gain providing typical nominal RLR around -4 dB. This implies for this example that the gain from the 2-wire interface to the EUT FP uniform PCM reference point interface should be 3 dB - (-4 dB) = 7 dB.

7.6.3.3.2.3 Distortion

The requirements and associated test methods of clause 4.2.4 of TBR 038 [29] shall apply, except that the test with input e.m.f. of 0 dBV in clause 4.2.4.2 of TBR 038 [29] shall be deleted.

NOTE: The 0 dBV level is too high and is not applicable to a digital system like DECT.

7.6.3.3.2.4 Noise

The requirements and associated test methods of clause 4.2.6 of TBR 038 [29] shall apply, except in the test of clause 4.2.6.1 of TBR 038 [29], where the noise acceptance criteria shall be -60 dBVp for feeding resistance R_f set to 2 800 Ω , 1 000 Ω and 500 Ω .

7.6.3.3.2.5 Echo Return Loss

The requirements and associated test methods of clause 4.2.8 of TBR 038[29] shall apply.

7.6.3.4 FP Delay

Requirement:

The sum of the delays from the line interface to the air interface and from the air interface to the line interface (round-trip delay) shall not exceed 20,5 ms including the A/D and D/A converters at the interface to the external network. This value includes the 5 ms delay of the reference PP looping back the ADPCM digital signal towards the FP.

7.6.4 Transmission characteristics for FP type 3 (Fixed Part with VoIP interface, 3,1 kHz service)

7.6.4.1 Send delay

For a VoIP Fixed Part, send delay is defined as the one-way delay from the air interface of this VoIP Fixed Part to its interface to the packet-based network.

It is desirable that the FP keeps this delay as low as possible.

An informative guideline for this requirement is provided in clause F.1.1.1.

7.6.4.2 Receive delay

For a VoIP Fixed Part, receive delay is defined as the one-way delay from the interface to the packet based network of this VoIP terminal to its air interface.

It is desirable that the FP keeps this delay as low as possible.

An informative guideline for this requirement is provided in clause F.1.1.2.

7.6.4.3 Adaptive volume control

Requirement:

An adaptive volume control, depending on the level of environmental noise at the PP, may be implemented into the FP. The gain variation shall be symmetrical, i.e. the increase in the receiving direction shall be equal to the decrease in the sending direction.

If the PP adaptive volume control feature is implemented then the FP adaptive volume control feature shall be disabled.

See annex D for further information.

Measurement method:

See EN 300 176-2 [10].

7.6.5 Transmission characteristics for FP type 4 (Fixed Part with ISDN network interface, wideband service)

7.6.5.1 FP adaptive volume control

Requirement:

An adaptive volume control, depending on the level of environmental noise at the PP, may be implemented into the FP. The gain variation shall be symmetrical, i.e. the increase in the receiving direction shall be equal to the decrease in the sending direction.

If the PP adaptive volume control feature is implemented then the FP adaptive volume control feature shall be disabled.

See annex D for further information.

Measurement method:

See EN 300 176-2 [10].

7.6.5.2 FP Delay

Requirement:

The sum of the delays from the digital line interface to the air interface and from the air interface to the digital line interface (round-trip delay) shall not exceed 20 ms. This value includes the 5 ms delay of the reference PP looping back the ADPCM digital signal towards the FP.

NOTE: Some extra delay due to optional features can exist.

Measurement method:

See EN 300 176-2 [10].

7.6.6 Transmission characteristics for FP type 5 (Fixed Part with VoIP interface, wideband service)

7.6.6.1 Send Delay

For a VoIP Fixed Part, send delay is defined as the one-way delay from the air interface of this VoIP Fixed Part to its interface to the packet-based network.

It is desirable that the FP keeps this delay as low as possible.

An informative guideline for this requirement is provided in clause F.1.2.1.

7.6.6.2 Receive delay

For a VoIP fixed part, receive delay is defined as the one-way delay from the interface to the packet based network of this VoIP terminal to its air interface.

It is desirable that the FP keeps this delay as low as possible.

An informative guideline for this requirement is provided in clause F.1.2.2.

7.6.6.3 FP adaptive volume control

Requirement:

An adaptive volume control, depending on the level of environmental noise at the PP, may be implemented into the FP. The gain variation shall be symmetrical, i.e. the increase in the receiving direction shall be equal to the decrease in the sending direction.

If the PP adaptive volume control feature is implemented then the FP adaptive volume control feature shall be disabled.

See annex D for further information.

Measurement method:

See EN 300 176-2 [10].

8 Additional features

8.1 Loudspeaking hands-free and headset facilities

8.1.1 Loudspeaking hands-free facility

Loudspeaking handsfree facility may be provided by means of the PP audio types 3a, 3b, 4a or 4b described in clause 7.2.

These audio types are applicable to either: 1) specific PPs designed to operate in handsfree mode, 2) standard handset implementing audio types 1 or 2, but with the option to operate in handsfree mode, and 3) handsfree accessory devices connected to a handset by any wired or wireless technology.

If loudspeaking and/or handsfree telephony is implemented in a handset, this device when operating in normal handset mode shall fulfil any of the audio types for handsets (types 1 or 2 of clause 7.2).

8.1.2 Headset facility

Headset accessory devices connected to a DECT PP by any wired or wireless technology are considered handsets from audio profile point of view. The sub-system composed by the DECT PP (muted), the wire or wireless link and the headset speaker-microphone set, shall fulfil any of the profile types for handsets (types 1 and 2 of clause 7.2).

8.2 Tandem with mobile radio network

A tandem of DECT with a mobile radio network shall provide a radio link between the DECT FP and a network, e.g. the PSTN/ISDN.

A speech path shall be provided by connecting a PCM 0 dBr reference point at the line side of the RFP, with a PCM 0 dBr speech reference point of a mobile radio transceiver.

For tandeming with analog mobile communication networks, national planning rules shall be applied. Tandeming with GSM is specified in clause 8.1.1.

8.2.1 Tandem with GSM

The FP is interfaced via its uniform PCM interface point to the 0 dB_r PCM X-interface point of a GSM mobile radio. See figure 8.1.

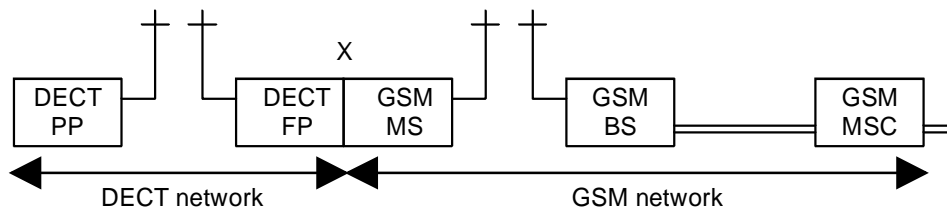

Figure 8.1: DECT in tandem with the GSM mobile network

8.2.1.1 Network echo control

The network echo control devices inserted in the FP to meet the extra echo loss requirements described in clauses 7.6.1.2, 7.6.2.1 and 7.6.3.2 are not required for tandem connections with GSM. If they are implemented in the FP, they shall be disabled.

NOTE: The echo from the GSM network is controlled by the Mobile Switching Centre (MSC) echo canceller in the GSM fixed network, as stated in ETS 300 540 [31].

8.2.1.2 Terminal coupling loss

There are two cases depending upon the mode of the GSM mobile transmitter operation. The mode may change from call to call.

8.2.1.3 The GSM mobile transmitter operates in continuous mode

An echo control device shall be implemented at the FP or the GSM side of the PCM reference point. It shall meet the requirement b) of clause 7.6.1.1. If the PP has $TCL_w > 46$ dB, the echo device shall be disabled.

8.2.1.4 The GSM mobile transmitter operates in discontinuous mode, DTX

The echo device described in clause 7.6.1.1 shall be disabled.

The GSM mobile transmitter shall not be activated (double-talk state) by a sending speech signal with a level of less than 30 dB below the receiving speech level.

The mobile combination of a DECT FP and a GSM mobile is a specially designed unit. This unit shall meet the 30 dB requirement irrespectively of whether the GSM DTX design itself meets this requirement or not. See annex C for information on GSM, DTX.

8.3 DECT connected to the GSM fixed network

In this application DECT provides a Base Station Sub-system, BSS, to the GSM network. Neither the GSM radio link nor the GSM codec is involved.

The FP is interfaced via its uniform PCM interface point to the 0 dB_r PCM A-interface point of a GSM Network (MSC). See figure 8.2.

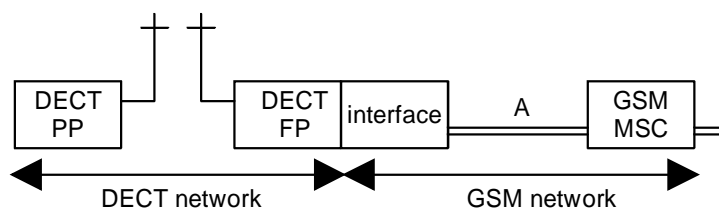

Figure 8.2: DECT in tandem with the GSM fixed network

8.3.1 Network echo control

The network echo control devices inserted in the FP to meet the extra echo loss requirements described in clauses 7.6.1.2, 7.6.2.1 and 7.6.3.2 are not required for tandem connections with GSM. If they are implemented in the FP they shall be disabled.

NOTE: The echo from the GSM network is controlled by the Mobile Switching Centre (MSC) echo canceller in the GSM fixed network, as stated in ETS 300 540 [31].

8.3.2 Terminal coupling loss

An echo control device shall be implemented at the FP or the GSM side of the PCM reference point. It shall meet the requirement b) of clause 7.6.1.1. The echo device may be disabled in accordance with optionally available routing information. If the PP has $TCL_w > 46$ dB, the echo device shall be disabled.

8.4 Wireless Relay Stations (WRS)

The connection between the FT and the WRS is wireless via the closest RFP. A WRS is locked to the closest RFP, or closest WRS when cascading WRSs is allowed. An RFP and a WRS, appear equal to a PP. See figure 8.3.

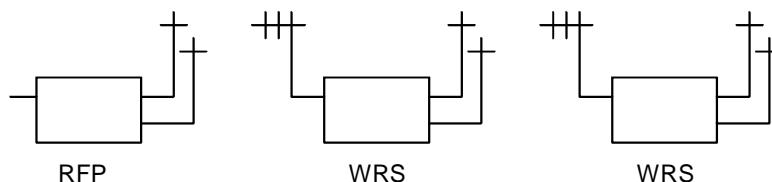

NOTE: A WRS is locked to the closest RFP, or closest WRS when cascaded WRSs are allowed. An RFP and WRS, appear equal to a PP.

Figure 8.3: FT connection to WRSs

Due to the wireless link, a PP connection to a WRS introduces an incremental delay in relation to a connection to an RFP. The incremental average 1-way delay for speech is 5 ms per cascaded CRFP and maximum 2,5 ms for any chain of cascaded REPs.

This incremental delay causes no fundamental limitation for the speech services.

The DECT speech quality requirements are met with the general DECT echo control requirements for the cases: one CRFP link and any chain of cascaded REP links.

NOTE: Compared to an RFP, a WRS may introduce capacity restrictions and higher blocking rate to the services offered. The restrictions may increase with the number of cascaded WRS links, especially for REPs. This will in practice limit a REP chain to three links.

When 2 or 3 CRFP links are cascaded, the FP network echo control requirements (see clauses 7.6.1.2, 7.6.2.1 and 7.6.3.2) may need to be modified depending on the characteristics of the specific network to which the FP is connected.

8.4.1 Modified FP network echo control requirements for implementation of 2 and 3 CRFP links in cascade

These modifications refer to the Requirement of clauses 7.6.1.2 and 7.6.2.1 and to the Requirement 1 and Requirement 2 of clause 7.6.3.2.

- RFP with 4-wire digital interfaces (type 1a or 1b)

Modification refers to the requirement of clauses 7.6.1.2 or 7.6.2.1.

Number of cascaded CRFP links:	2	3
Inserted echo loss:	> 11 dB	> 12 dB

- RFP with 2-wire analog interfaces (type 2)

Modification refers to the requirements 1 and 2 of clause 7.6.3.2.

Number of cascaded CRFP links:	2	3
Requirement 1 (0-4 ms TELR):	> 27 dB	> 29 dB
Requirement 2 (4-60 ms Extra echo loss):	> 11 dB	> 12 dB

Requirement 1 does not apply when the FP has a 4-wire through connection to the PSTN/ISDN. Nor do the requirements 1 or 2 apply when the FP is connected to a GSM network, because the corresponding echo control function shall be disabled if implemented.

NOTE: A general solution for the modified Requirements 1 and 2 is to apply an echo canceller for TELR 29 dB and 0 ms to 60 ms control range.

Annex A (informative): Description of "reference" echo control devices

The present annex describes reference echo control devices based upon concepts that are as simple as possible but include a sufficient number of features to give guidance for a wide range of possible implementations. The use of the term "reference" denotes an implementation given for guidance and illustration only. It does not exclude other implementations nor does it imply that the described devices are necessarily the most appropriate realization on any technical, operational or economic grounds. See ITU-T Recommendation G.168 [i.21].

A.1 Handset echo

This clause only applies to FP type 1a and FP type 2.

A.1.1 Overview

A.1.1.1 Connection to the PSTN/ISDN

FPs with 4-wire connection should provide the artificial echo specified in clause 7.6. It should be disabled if the PP meets the requirements of clause 7.6 $TCLw > 46$ dB, and may be disabled on available call routing information.

The combined handset and hybrid echo from analog telephones is considerably higher than the DECT 34 dB $TCLw$ echo. Therefore the international planning rules demand provision of echo control devices in the public network, depending on the one-way network echo delay and the Talker Echo Loudness (TEL_R) according to ITU-T Recommendation G.131 [30].

A.1.1.1.1 Local and national calls

The 34 dB $TCLw$ for a DECT system will give the far-end user a TEL_R of about 44 dB. According to the "acceptable" curve of figure 1 in ITU-T Recommendation G.131 [30], a mean one-way transmission time of 70 ms could be accepted. The delay requirements will be met for the majority of national connections with DECT system at one end, at both ends of the connection and also with a DECT tethered local loop replacement in the public network.

A.1.1.1.2 Long distance connections with echo control devices in the PSTN/ISDN, e.g. calls via satellites

Echo control devices are provided in the public network according to the guidelines of ITU-T Recommendation G.131 [30]. It is nowadays recommended only to deploy echo cancellers that conform to ITU-T Recommendation G.168 [i.21]. Older echo canceller equipment conforms to G.165 [i.20]. Older echo suppressor devices according to G.164 [i.19] may also be in use.

The echo path delay capabilities of modern echo cancellers are often 64 ms (or more). These echo cancellers will eliminate echoes with less than 30 ms one-way delay.

However, as long as these devices are active, they will also eliminate the DECT acoustic echo. The 34 dB attenuated echo is low enough not to be detected as break-in speech during single talk condition during speech from the far-end. The DECT echo will therefore be eliminated by an echo suppressor or by the Non-Linear Processor (centre clipper), NLP, of an echo canceller, whichever device is used. Both the suppressor and the NLP have hangover times which will prevent the delayed DECT echo to be heard even at the end of a speech sentence.

The artificial echo, clause 7.6 simulates the echo from a very good analog 2-wire telephone. When an echo canceller is used in the network, the artificial echo loss path provides an echo, that is guaranteed in-range for the linear echo estimation process. This will ensure that the echo canceller and its NLP are active. The artificial echo is principally not needed to keep echo suppressors nor all types of echo cancellers active, but it does not hurt either.

A.1.1.2 Connection to the GSM network

When a DECT system is connected in tandem with a GSM mobile network (see clause 8.1.1) or a GSM fixed network (see clause 8.1) the FP provides the echo control function specified in clause 7.6.1 It should be disabled if the PP meets the requirement $TCL_w > 46$ dB, and for the case of Discontinuous, DTX, specified in clause 8.1.1.4.

Echo control function specified in clause 7.6 should be disabled.

A.1.2 Implementation of the FP echo control function

The FP echo control function is described in clause 7.6.

The needed extra echo loss can preferably be implemented by using a Non-Linear Processor (NLP) that, when active, clips all sending signals lower than the suppression threshold. See figure A.1.

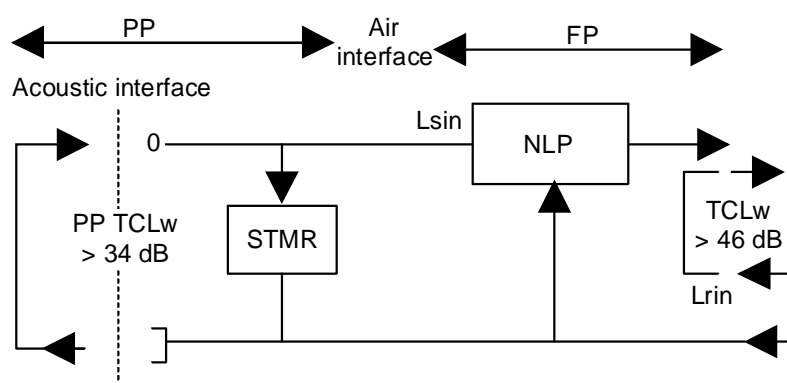

Figure A.1: Implementation of the handset echo control

Such a NLP is described in ITU-T Recommendation G.168 [i.21], annex B. Two variants are included, both based on an analog centre clipper having the transfer function illustrated in figure A.2.

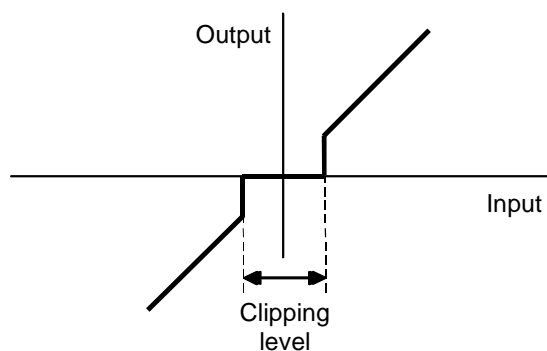

Figure A.2: Transfer function of non-linear processor

In the first case the suppression threshold level is adaptive, adaptation being by reference to L_{rin} . In the second variant the suppression level is fixed.

A.1.2.1 Suppression threshold

The value of the suppression threshold depends on the handset acoustic TCL, below called PTCL:

Fixed: $V_{sup} = (-PTCL) \text{ dBm0}$;

Adaptive: $V_{sup} = (L_{rin} - PTCL + 6) \text{ dBm0}$.

6 dB is the operation margin that prevents the possible ambient noise to pass through the activated NLP. If the noise is high enough to pass through, it will also be high enough to mask the echo.

PTCL is $> 34 \text{ dB}$.

If for example PTCL is set to 30 dB then:

$V_{sup} = -30 \text{ dBm0}$; or

$V_{sup} = L_{rin} - 24 \text{ dB}$.

A.1.2.2 Static characteristics of activation control

In annex B of ITU-T Recommendation G.168 [i.21], the activation control is defined by reference to L_{rin} . The NLP is active when the level of signal in the sending direction L_{sin} is lower than the activation threshold V_{act} :

Fixed: $V_{act} = (L_{rin} - 6) \text{ dBm0}$;

Adaptive: $V_{act} = (L_{rin} - PTCL + 6) \text{ dBm0}$.

As we are dealing here with acoustic echo in a terminal equipment instead of electric echo in the network, a simplification seems reasonable and V_{act} can be fixed:

$V_{act} = -31 \text{ dBm0}$.

A.1.2.3 Dynamic characteristics of activation control

Table A.1: Non-linear processor hangover times

Switch from	V_{sup} variant	Recommended values
active to inactive	fixed	15 ms to 64 ms
	Adaptive	2 ms (echo path delay)
inactive to active	fixed	20 ms to 120 ms
	Adaptive	30 ms to 50 ms

A.2 Network echo

This clause only applies to FP types 1a, 1b and 2.

The requirement on network echo control (see clause 7.6) can be met with the following implementation, depending on the type of line interface:

- 1) for digital circuit switched (4-wire) interface (FP types 1a and 1b), a soft suppressor (see figure A.3);
- 2) for analog (2-wire) interface (FP type 2), a soft suppressor and an echo canceller (see figure A.4).

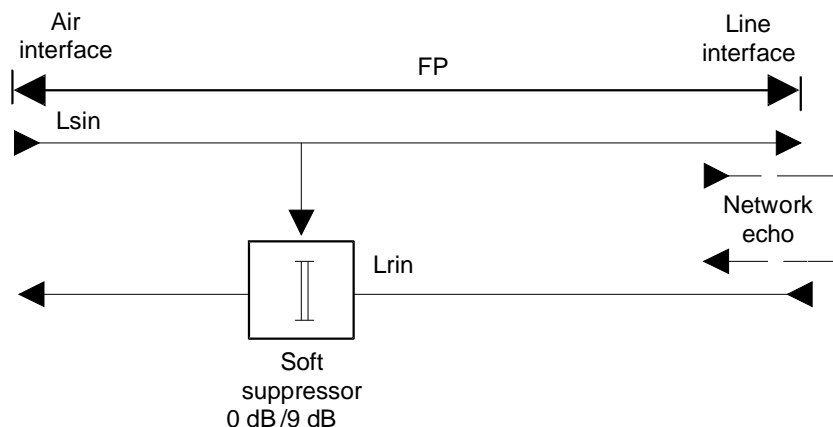

Figure A.3: Implementation of the network echo control 4-wire line interface

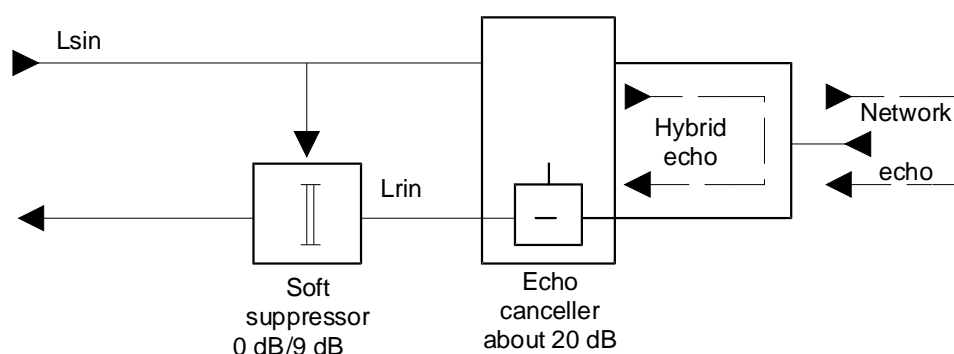

Figure A.4: Implementation of the network echo control 2-wire line interface

A.2.1 Soft suppressor implementation of requirement 2

A 9 dB soft echo suppressor meets the whole requirement for 4-wire connection and a part of the requirement for the 2-wire connection. The principle of operation is similar to the one described in ITU-T Recommendation G.164 [i.19]. Therefore the same operational parameters can be used.

The 9 dB to 12 dB loss for requirement 2 is intended to cover different foreseen connection cases. It is also a compromise between reduction of echoes from badly matched far-end national hybrids, and low noise contrast requirements.

In most applications the majority of calls will not need any extra echo suppression, and therefore optimization should be made to minimize the noise contrast. Thus the lower 9 dB value is recommended.

The 9 dB to 12 dB loss is required when no routing information is available. When suitable routing information is available, the operator is allowed to disconnect or reduce the loss below 9 dB to optimize it for specific connections or applications.

This parameter of requirement 2 only affects the DECT user and not the general network planning rules.

A.2.1.1 Static characteristics

The echo suppressor is active if the speech level in the sending direction L_{sin} is greater than the suppression threshold:

$$V_{sup} = -31 \text{ dBm0.}$$

The suppressor becomes inactive if the speech level falls under the release threshold:

$$V_{rel} = V_{sup} (+0 \text{ dB}, -3 \text{ dB}).$$

A.2.1.2 Dynamic characteristics

The switching characteristics are taken from ITU-T Recommendation P.340 [22], that relates to terminal equipment and seems more appropriate than ITU-T Recommendation G.164 [i.19], that relates to network echo suppressor ($T_r \leq 2 \text{ ms}$ and $T_h = 24 \text{ ms}$ to 36 ms).

- 1) Build-up time: $T_r < 15 \text{ ms}$, preferably $< 10 \text{ ms}$.
- 2) Hang-over time: $T_h > 100 \text{ ms}$, preferably between 150 ms and 250 ms .

The soft suppressor may pass a 6 dB state at the switch on and switch off of the 9 dB to 12 dB attenuation. The 6 dB state should be of less than 15 ms duration.

A.2.2 Additional echo control for a 2-wire interface of requirement 1

For the 2-wire case a Talker's Echo Loudness Rating (TELR) of 24 dB is required for the delayed sidetone from the FP's 2-wire interface. This can be performed in some cases by hybrid matching, or more generally by means of an echo canceller.

In order to meet the requirement of $TELR = 24 \text{ dB}$ for the three terminating impedances according to clause 7.6.3.2, around 20 dB extra loss is estimated to be required for the worst cases of mismatch. This implies that for normal cases, $TELR > 30 \text{ dB}$ is expected for the delayed sidetone.

$TELR = 24 \text{ dB}$ equates to $LL_e = 14 \text{ dB}$ at the PCM reference point of the FP.

NOTE: The solution using an adaptive soft suppressor with up to 20 dB attenuation is not recommended.

Such an echo canceller should be rather simple to implement since the control range is limited to 4 ms. But it is peculiar in the sense that the near-end echo may be equal or even higher than the far-end signal.

The echo canceller is operating on the uniform PCM speech signals. It makes a linear estimate A_{canc} of the echo path A_{echo} (see figure A.5), and subtracts this estimate at the subtractor. The residual echo level after the subtractor is L_{res} . L_{fes} is the level of the far-end speech.

$$L_{res} = L_{sin} - A_{echo} - A_{canc} \text{ (in power);}$$

$$L_{rout} = L_{res} + L_{fes}.$$

Since the worst case A_{echo} is -1 dB, the required A_{canc} is about $15 - A$ dB. Therefore no NLP is needed to further reduce L_{rout} . A is the attenuation of the soft suppressor for requirement 2. If the soft suppressor can be disabled (e.g. for local PABX calls), A is set to zero during type approval testing (see EN 300 176-2 [10]).

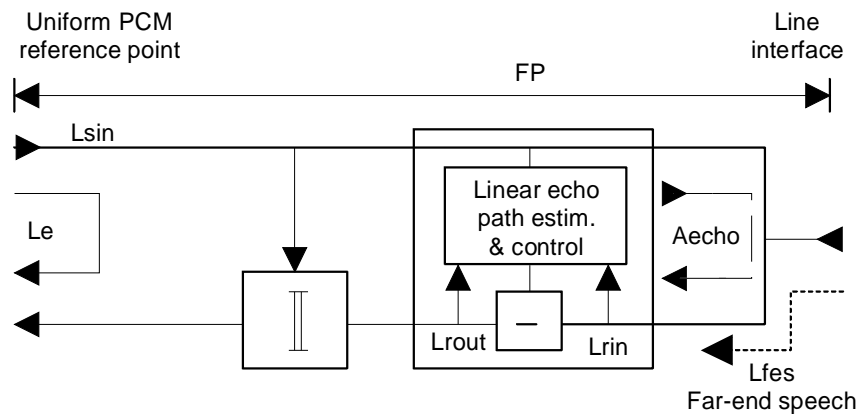

Figure A.5: Echo canceller implementation

Speech detection for e.g. double talk, cannot be made before the subtractor (L_{rin}), as in ITU-T Recommendation G.168 [i.21], because the level of the hybrid echo can be larger than the level of the far-end signal.

Detection of the far-end speech has to be made after the subtractor (L_{rout}), and detection is only possible when the near end echo is cancelled to a certain degree.

Thus at the start (adaptation coefficients = 0), the FES detector is switched off. It is switched on once L_{rout} is below a certain threshold. This will only happen when L_{fes} is very low and the filter adaptation is satisfying (L_{res} low).

At detected double talk, the adaptation cannot be completely switched off, but the adaptation speed should be reduced by a factor of e.g. 4. This allows adaptation during conversation if the echo path suddenly is changed.

A.2.3 Echo canceller used for both requirements 1 and 2

An alternative to implementing a soft suppressor, is to use an echo canceller as described in clause A.2.2 with the control range prolonged to 70 ms. This solution may be more expensive, but will give better performance for PP reception on a noisy connection.

Annex B (informative): Local loop application

The present annex relates to public local loop applications.

A PP is a physical grouping that contains all elements between the user and the DECT air interface. A PP is a generic term that may describe one or several physical pieces.

A PP is logically divided into one PT plus zero or more Terminal Adaptors (TA) plus one or more End Systems (ESs).

The ES can thus be implemented in a handset, or be e.g. a standard ISDN terminal, a standard 2-wire telephone or even a cordless telephone system, tethered to a TA via a standard subscriber's telephone socket.

Below, guidance is given for the case when the ES is connected via a standard 2-wire socket, e.g. in a public local loop evolutionary application.

B.1 DECT tethered local loop replacement with 2-wire PP end system

Below we consider the case when a public operator uses DECT for a local loop replacement.

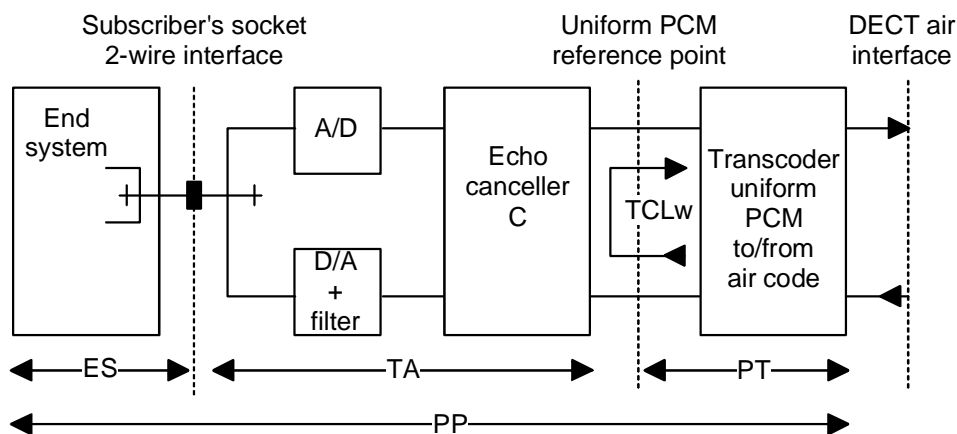

Figure B.1: PP in tethered local loop application

B.1.1 TCLw requirements

If the public operator plans the control range of his echo cancellers at the international gateways to include the hybrid at the subscriber's socket interface and a standard telephone end system, then no extra echo canceller C is needed.

If the hybrid in figure B.1 is outside the control range of the echo cancellers at the international gateways, then the hybrid's echo return loss LL_e has to be > 34 dB. If this is not met, an echo canceller C, with about 20 dB extra echo attenuation and with a 4 ms control range, of the same type as described in clause A.2.2 (without the soft suppressor) is needed in the PP TA.

The echo control device may in principle for some installation cases, alternatively be implemented at the FP with a control range of 20 ms to 28 ms (or more if Wireless Base Stations (WBSs) are implemented). At the FP some trunking gain can be provided on needed number of simultaneous echo control functions.

If the ES has higher loop delay than a standard telephone (2 ms), e.g. a residential DECT system, this system has to meet the normal TCLw requirements of clause 7.5.1.4.1. See clauses A.1.1.1.1 and A.1.1.1.2.

B.1.2 Network echo

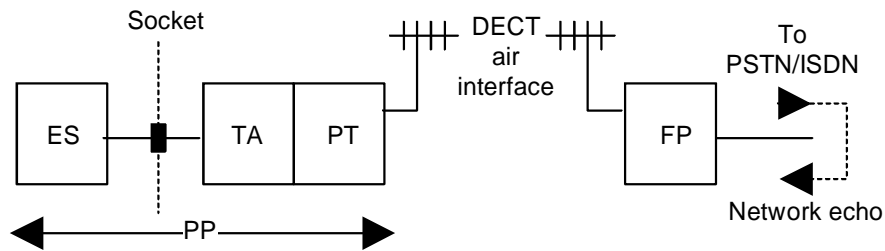

Figure B.2: DECT local loop replacement

The FP of figure B.2 has to meet the normal echo control requirements 1 and 2 of clause 7.6.3.2.

If the ES is a (residential) DECT system, each FP will meet the requirement of clause 7.6.3.2 and take care of its own network echo.

It is however recommended that requirement 2 is realized with an echo canceller, or a soft suppressor with reduced echo loss if the operator has a modern network, see clause A.2.1.

This recommendation is to minimize the noise contrast for the case when the ES is a DECT residential system, also implementing requirement 2.

It is allowed to disconnect or reduce requirement 2, when suitable routing information is available. This may be the case for FPs under control of one operator in a local loop application. For instance, if an operator has a modern network where the far-end hybrids have $LL_e > 20$ dB, a reduction to 6 dB could be suitable if the loss in the FP in figure B.2 is implemented as a soft suppressor and not as an echo canceller.

Annex C (informative): GSM Discontinuous Transmission (DTX), and Voice Activity Detection (VAD)

Discontinuous Transmission (DTX) and Voice Activity Detection (VAD) are mandatory features in a GSM mobile, but not in a GSM base station. A GSM mobile has to be able to operate in both modes.

Without DTX and VAD in the up-link, TCL 34 dB and NLP in the FP meet the requirements.

If VAD and DTX is implemented the DECT TCL echo path is broken except for double talk. At double talk TCL 34 dB should be enough, since the echo level will be 34 dB below the (annoying) double talk and is masked by the double talk. Furthermore double talk occupies only a small fraction of the speech time.

The 34 dB attenuated echo is not interpreted as a speech break-in signal. When DTX is implemented, the normal background speech or music in a public environment should not eliminate the DTX function. For example, in ITU-T Recommendations G.164 [i.19], G.165 [i.20] and G.168 [i.21] double talk state occurs only if the "sending speech" level is higher than the "receiving speech" level - 6 dB.

The VAD is extracting noise parameters in speech pauses in the signal from the microphone (sending speech). The VAD might need to detect speech pauses at -40 dBm0 to -45 dBm0 levels, in order to deliver clean noise parameters to the GSM base station, for noise insertion in DTX pauses. But these low levels need not be related to levels required to prevent background speech or an acoustic echo to eliminate the DTX function. The VAD is specially designed for traffic and motor noise in a car, and not optimized for an environment with background speech and music.

Therefore it is stated in clause 8.2.1.4 "that the GSM mobile transmitter shall not be activated (double-talk state) by a sending speech signal with a level of less than 30 dB below receiving speech level". If ITU-T Recommendations G.164 [i.19], G.165 [i.20] and G.168 [i.21] are used as guidance for an upper level, a threshold may be implemented somewhere in the range 6 dB to 30 dB below the level of the speech received from the far-end.

Annex D (informative): Speech levels in relation to ambient room noise and examples of adaptive volume control settings

When room noise is present a higher received speech signal level (lower RLR_H) is required to give the best possible receiving speech quality and intelligibility. The increase in the receiving level is a function of increasing room noise level.

When room noise is present people raise their voice level (talk louder) and the sending speech level will be higher than the optimum level. By decreasing the sending sensitivity (higher SLR_H) the sending level to the line will be around optimum and at the same time the absolute level of the transmitted noise will decrease.

The increase in receiving sensitivity and the decrease in sending sensitivity is approximately linearly related to increasing room noise level. For every dB increase in room noise level there is a corresponding increase in receiver sensitivity and decrease in sending sensitivity of about 0,5 dB.

Table D.1 presents - for guidance and illustration only - three examples of volume control characteristics.

Table D.1: Examples of FP adaptive volume control

Ambient noise		Volume variation receiving (sending)	
Single threshold	Between 50 dBA and 55 dBA	8 dB gain	(attenuation)
Double threshold	50 dBA 60 dBA	5 dB gain 10 dB gain	(attenuation) (attenuation)
Continuous variation	from 30 dBA to 50 dBA From 50 dBA to 70 dBA	3 dB increase 8 dB increase	(decrease) (decrease)

Annex E (informative): Echo related topics

E.1 Summary table on echo parameters for PPs and FPs

The following table summarizes the requirements for PPs and FPs and the consequences for implementations.

NOTE 1: The value of TCLw given in this table is for nominal setting of volume control.

NOTE 2: Handsfree or loudspeaking audio feature is not analysed in this table., because flag is send during registration which is negotiated with "base" function handset. TCLw being different (generally lower) during handsfree or loudspeaking mode, there can be some echo problems in case of long delay networks.

Table E.1: Summary on echo parameters for narrowband PP types

Table for Narrowband PP types									
Applicable to:	Type nr.	Audio type name	Clause	TCLw Requirement for type (dB)	TCLw Real Value (dB)	Setting of flags "echo parameter" (bits 5 and 6 in octet 3b) of IE <TC>	Action for FP type 1a	Action for FP type 1b or 3	Action for FP type 2
PP	1a	Classic GAP handset narrowband	7.2.3 7.5.4.1	> 34	> 34	01	Mandatory insertion of "PP echo control" (any of the alternatives described in 7.6.1.1)	Optional insertion of echo canceller (7.4.2) or echo suppressor (7.4.3) if implemented	Nothing (transparent)
				> 34	> 46	10	Insertion of "PP echo control" (any of the alternatives described in 7.6.1.1) is NOT recommended. (However, it is allowed by the standard)	Optional insertion of echo canceller (7.4.2) if implemented. Echo suppressor should not be inserted.	Nothing (transparent)
				> 34	> 55	11	Insertion of "PP echo control" (any of the alternatives described in 7.6.1.1) is NOT recommended. (However, it is allowed by the standard)	Nothing (transparent)	Nothing (transparent)

Table for Narrowband PP types									
Applicable to:	Type nr.	Audio type name	Clause	TCLw Requirement for type (dB)	TCLw Real Value (dB)	Setting of flags "echo parameter" (bits 5 and 6 in octet 3b) of IE <TC>	Action for FP type 1a	Action for FP type 1b or 3	Action for FP type 2
	1b	Improved GAP handset narrowband	7.2.4 7.5.2.1	> 55	> 55	11	Insertion of "PP echo control" (any of the alternatives described in 7.6.1.1) is NOT recommended. (However, it is allowed by the standard)	Nothing (transparent)	Nothing (transparent)
	1c	HATS tested, "standard" narrowband handset	7.2.5 7.5.3.4	> 55	> 55	11	Insertion of "PP echo control" (any of the alternatives described in 7.6.1.1) is NOT recommended. (However, it is allowed by the standard)	Nothing (transparent)	Nothing (transparent)
	1d	HATS tested, "improved" narrow band handset	7.2.6 7.5.3.4	> 55	> 55	11	Insertion of "PP echo control" (any of the alternatives described in 7.6.1.1) is NOT recommended. (However, it is allowed by the standard)	Nothing (transparent)	Nothing (transparent)

Table E.2: Summary on echo parameters for wideband PP types

Table for Wideband PP types									
Applicable to:	Type nr.	Audio type name	Clause	TCLw Requirement for type (dB)	TCLw Real Value (dB)	Setting of flags "echo parameter" (bits 5 and 6 in octet 3b) of IE <TC>	Action for FP type 4 or 5		
	2a	ITU-T P.311 [20] tested, wideband handset	7.2.9 7.5.5.4.1	> 42	> 42	01	Optional insertion of echo canceller (7.4.2) or echo suppressor (7.4.3) if implemented		
				> 42	> 46	10	Optional insertion of echo canceller (7.4.2) if implemented. Echo suppressor should not be inserted.		
				> 42	> 55	11	Nothing (transparent)		
	2b	HATS tested, "standard" wideband handset	7.2.10 7.5.6.4.1	> 55	> 55	11	Nothing (transparent)		
	2c	HATS tested, "improved" wideband handset	7.2.11 7.5.6.4.1	> 55	> 55	11	Nothing (transparent)		

Table E.3: Summary on echo parameters for FPs types

Table for FPs								
Applicable to:	Type nr.	Audio type name	Clause	TCLw Requirement for type (dB)	TCLw Real Value (dB)	Flag "echo parameter" (bits 5 and 6 in octet 3b of Terminal Capability)	Action	Clause (echo handling)
FP	1a	"classic" Fixed Part with ISDN interface, narrowband service	7.3.2			(if PP = 01)	Mandatory insertion of "PP echo control" (any of the alternatives described in 7.6.1.1)	7.6.1.1, see also A.1
						(if PP = 10)	Insertion of "PP echo control" (any of the alternatives described in 7.6.1.1) is NOT recommended. (However, it is allowed by the standard)	7.6.1.1, see also A.1
						(if PP = 11)	FP type 1a does not need to distinguish PP = 11. Action is as for PP = 10 Insertion of "PP echo control" (any of the alternatives described in 7.6.1.1) is NOT recommended. (However, it is allowed by the standard)	7.6.1.1, see also A.1
	1b	"new" Fixed Part with ISDN interface, narrowband service	7.3.3			(If PP = 01)	Optional insertion of echo canceller (7.4.2) or echo suppressor (7.4.3) if implemented	7.4.2, 7.4.3
						(If PP = 10)	Optional insertion of echo canceller (7.4.2) if implemented. Echo suppressor should not be inserted.	7.4.2
						(If PP = 11)	Nothing (transparent). FP will not insert echo canceller or suppressor	7.4
	2	Fixed Part with analog 2-wire interface, narrowband service	7.3.4				Nothing.	See A.1
	3	Fixed Part with VoIP interface, narrowband service	7.3.5			(If PP = 01)	Optional insertion of echo canceller (7.4.2) or echo suppressor (7.4.3) if implemented	7.4
						(If PP = 10)	Optional insertion of echo canceller (7.4.2) if implemented. Echo suppressor should not be inserted.	7.4.2
						(If PP = 11)	Nothing (transparent). FP will not insert echo canceller or suppressor	7.4

Table for FPs								
Applicable to:	Type nr.	Audio type name	Clause	TCLw Requirement for type (dB)	TCLw Real Value (dB)	Flag "echo parameter" (bits 5 and 6 in octet 3b of Terminal Capability)	Action	Clause (echo handling)
	4	Fixed Part with ISDN interface, wideband service	7.3.6			(If PP = 01)	Optional insertion of echo canceller (7.4.2) or echo suppressor (7.4.3) if implemented	7.4
						(If PP = 10)	Optional insertion of echo canceller (7.4.2) if implemented. Echo suppressor should not be inserted.	7.4.2
						(If PP = 11)	Nothing (transparent). FP will not insert echo canceller or suppressor	7.4
	5	Fixed Part with VoIP interface, wideband service	7.3.7			(If PP = 01)	Optional insertion of echo canceller (7.4.2) or echo suppressor (7.4.3) if implemented	7.4
						(If PP = 10)	Optional insertion of echo canceller (7.4.2) if implemented. Echo suppressor should not be inserted.	7.4.2
						(If PP = 11)	Nothing (transparent). FP will not insert echo canceller or suppressor	7.4

E.2 General information about Delay-Echo interaction for DECT terminals

The E-model of ITU-T Recommendation G.107 [i.14] gives a widely recognized tool to look into the impacts of various transmission and terminal parameters. The following diagram provides results of E-model calculations with Talker Echo Loudness Rating (TELR) and one-way delay as variables; all other parameters are left at their default values.

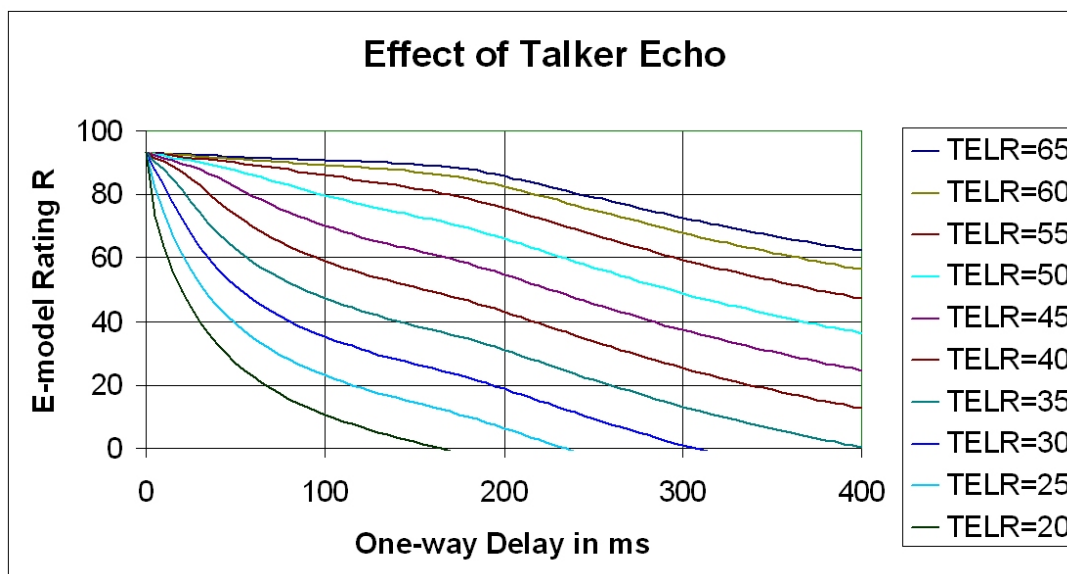

Figure E.1: E-model rating versus delay and TELR

For fully digital connections between terminals it can be simplified that:

TELR (perceived at talker's side) = (SLR + RLR) (at talker's side) + TCLw (at receiver's side).

With standard phones that leads to a further simplified formula:

$$\text{TCLw} = \text{TELR} - 10 \text{ dB}$$

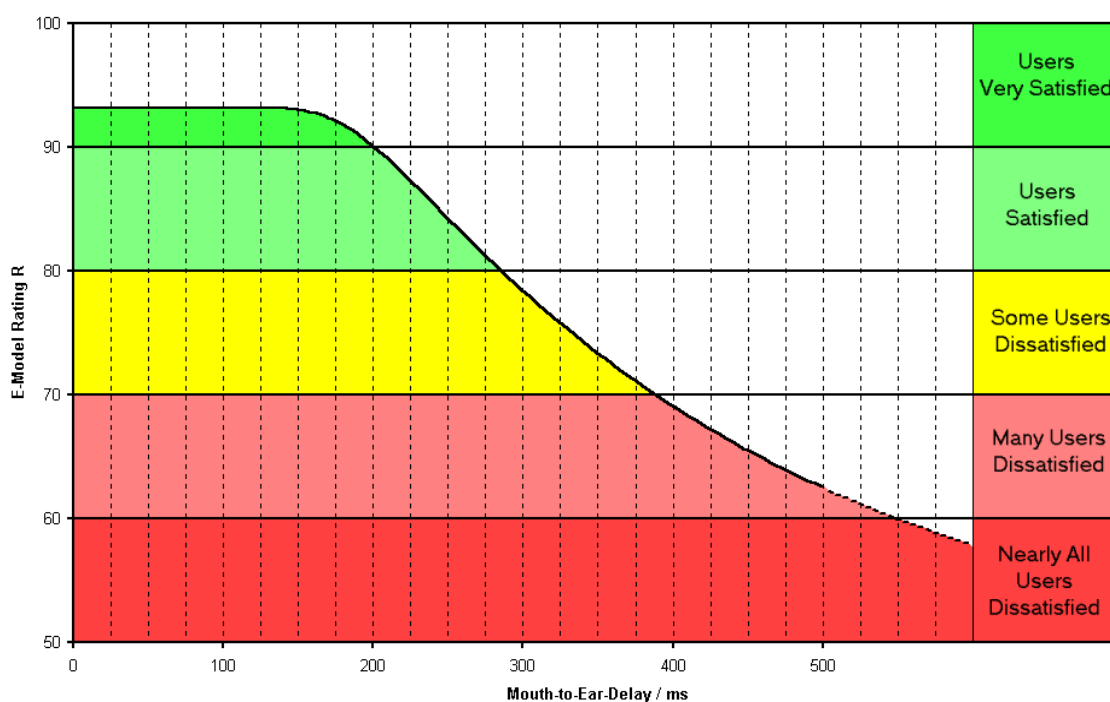

Figure E.2: Subjective rating versus E-model rating and round-trip delay

The result of an E-model calculation is an estimation of average user satisfaction which can according to ITU-T Recommendation G.109 [i.16] be interpreted as depicted above.

For the purpose of this short tutorial, four simple connection scenarios have been assumed. The delay of Next Generation Networks (NGN) has been assumed to be 150 ms in accordance with ITU-T Recommendation Y.1541 [i.25], class 0; the delay of the DECT system has been assumed to be 10 ms each.

EXAMPLE 1: DECT phone -> digital i/f -> NGN -> digital i/f -> DECT phone
T= 170 ms, TCLw = 34.

This example constitutes a case with an "classic" DECT GAP PP using the low TCLw option.

The resulting quality is **R=60**;

which translates into **"Many Users Dissatisfied/Nearly All Users Dissatisfied"**.

EXAMPLE 2: DECT phone -> digital i/f -> NGN -> digital i/f -> DECT phone
T= 170 ms, TCLw = 46.

This example constitutes a case with an "classic" DECT GAP PP using the high TCLw option.

The resulting quality is **R=80**;

which translates into **"Users Satisfied/Some Users Dissatisfied"**.

EXAMPLE 3: DECT phone -> digital i/f -> NGN -> digital i/f -> DECT phone
T= 170 ms, TCLw = 55.

This example constitutes a case with "improved" DECT GAP PP over an NGN.

The resulting quality is **R=88**;

which translates into **"Users Satisfied"**.

EXAMPLE 4: DECT phone -> digital i/f -> no network -> digital i/f -> DECT phone
T= 20 ms, TCLw = 34.

This example constitutes a case with an "classic" DECT GAP PP using the low TCLw option but no network delay involved.

The resulting quality is **R=89**;

which translates into **"Users Satisfied"**.

Annex F (informative): Guidelines on specific requirements

F.1 Delay requirements for FPs with VoIP interface

F.1.1 Delay requirements for FP type 3 (Fixed Part with VoIP interface, 3,1 kHz service)

The delay data provided assumes an IEEE 802.3 [i.24] (100 Mbit/s or faster) physical network interface. There can be differences in the delay figures if other interfaces are used.

F.1.1.1 Send delay

For a VoIP Fixed Part, send delay is defined as the one-way delay from the air interface of this VoIP Fixed Part to its interface to the packet-based network. The total send delay is the upper bound on the mean delay and takes into account the delay contributions of all of the elements shown in figure 2 of G.1020 [25] and in figure A.1 of G.1020 [25], respectively.

The sending delay $T(s)$ is defined as follows:

$$T(s) = T(ps) + T(ead) + T(aif) + T(asp) + T(tra)$$

Where:

$T(ps)$ = packet size = $N * T(fs)$;

N = number of frames per packet;

$T(fs)$ = frame size of encoder;

$T(ead)$ = additional encoder algorithmic delay (look-ahead filtering);

$T(aif)$ = air interface framing;

$T(asp)$ = allowance for signal processing;

$T(tra)$ = allowance for transcoding.

The additional delay required for IP packet assembly and presentation to the underlying link layer will depend on the link layer. When the link layer is a LAN (e.g. Ethernet), this additional time will usually be quite small. For the purposes of the present document it is assumed that in the test setup this delay can be neglected.

NOTE 1: The size of $T(aif)$ is for further study.

Informative values:

In order to use the formula it is needed to use a table such as provided below.

The allowance for signal processing should be $T(asp) < T(ps)$.

NOTE 2: With the knowledge of the codec specific values for $T(fs)$ the values for send delay for any type of coder and any packet size $T(ps)$ can easily be calculated by formula above. Table F.1 provides values calculated accordingly for frequently used codecs and packet sizes.

Table F.1: Example of the composition of the delay values

Codec over air i/f (DECT)	Codec over line i/f (VoIP)	N	T(fs) in ms	T(ps) in ms	T(ead) in ms	T(aif) in ms	T(asp) in ms	T (tra) in ms	T(s) Value in ms
G.726 [12]	G.711 [13]	80	0,125	10	0	0	10	< 1	< 21
		160	0,125	20	0	0	10	< 1	< 31
G.726 [12]	G.726 [12]	80	0,125	10	0	0	10		< 20
		160	0,125	20	0	0	10		< 30
G.711 [13]	G.711 [13]	80	0,125	10	0	0	10		< 20
		160	0,125	20	0	0	10		< 30

NOTE 3: There may be some extra delay due to optional features.

F.1.1.2 Receive delay

For a VoIP Fixed Part, receive delay is defined as the one-way delay from the interface to the packet based network of this VoIP terminal to its air interface. The total receive delay is the upper bound on the mean delay and takes into account the delay contributions of all of the elements shown in figure 3 of G.1020 [25] and in figure A.2 of G.1020 [25], respectively.

The receiving delay T(r) is defined as follows:

$$T(r) = T(fs) + T(dad) + T(aif) + T(jb) + T(plc) + T(asp) + T(tra)$$

Where:

T(fs) = frame size of decoder (=frame size of encoder);

T(aif) = air interface framing;

T(dad) = decoder algorithmic delay (filtering,...);

T(jb) = jitter buffer size;

T(plc) = PLC buffer size;

T(asp) = allowance for signal processing;

T(tra) = allowance for transcoding.

The additional delay required for IP packet dis-assembly and presentation from the underlying link layer will depend on the link layer. When the link layer is a LAN (e.g. Ethernet), this additional time will usually be quite small. For the purposes of the present document it is assumed that in the test setup this delay can be neglected.

NOTE 1: The size of T(aif) is for further study.

Informative values:

In order to use the formula it is needed to use a table such as provided below.

The allowance for signal processing by decoder should be $T(asp) < \max(T(plc), T(fs))$.

The additional delay introduced by the jitter buffer should be $T(jb) \leq 3 * T(ps)$.

For codecs without integrated PLC the additional PLC buffer size should be $T(plc) < 10$ ms.

For codecs with integrated PLC the additional PLC buffer size should be $T(plc) = 0$ ms.

NOTE 2: With the knowledge of the codec specific values for T(fs) the values for receive delay for any type of codec and any packet size T(ps) can easily be calculated by formula above. Table F.2 provides values calculated accordingly for some frequently used codecs and packet sizes as an example.

Table F.2: Example of the composition of the delay values

Codec over air i/f (DECT)	Codec over line i/f (VoIP)	N	T(fs) in ms	T(aif) in ms	T(dad) In ms	T(jb) in ms	T(plc) in ms	T(asp) in ms	T(tra) in ms	T(r) Value in ms
G.726 [12]	G.711 [13]	80	0,125	0	0	< 30	10	10	< 1	< 51,125
		160	0,125	0	0	< 60	10	10	< 1	< 81,125
G.726 [12]	G.726 [12]	80	0,125	0	0	< 30	10	10		< 50,125
		160	0,125	0	0	< 60	10	10		< 80,125
G.711 [13]	G.711 [13]	80	0,125	0	0	< 30	10	10		< 50,125
		160	0,125	0	0	< 60	10	10		< 80,125

$T(ps) = \text{packet size} = N * T(fs)$

N = number of frames per packet

NOTE 3: These values are based on the lowest possible delay values which can be expected under ideal network conditions. Caution must be exercised to ensure that the terminal is operated under optimum conditions in order to avoid adverse effects, e.g. network conditions, settings and memory effects of the terminal jitter buffer.

NOTE 4: There may be some extra delay due to optional features.

F.1.2 Delay requirements for FP type 5 (Fixed Part with VoIP interface, wideband service)

The delay data provided assumes an IEEE 802.3 [i.24] (100 Mbit/s or faster) physical network interface. There can be differences in the delay figures if other interfaces are used.

F.1.2.1 Send Delay

For a VoIP Fixed Part, send delay is defined as the one-way delay from the air interface of this VoIP Fixed Part to its interface to the packet-based network. The total send delay is the upper bound on the mean delay and takes into account the delay contributions of all of the elements shown in figure 2 of G.1020 [25] and in figure A.1 of G.1020 [25], respectively.

The sending delay $T(s)$ is defined as follows:

$$T(s) = T(ps) + T(ead) + T(aif) + T(asp)$$

Where:

$T(ps) = \text{packet size} = N * T(fs)$;

N = number of frames per packet;

$T(fs) = \text{frame size of encoder}$;

$T(ead) = \text{additional encoder algorithmic delay (look-ahead, filtering)}$;

$T(aif) = \text{air interface framing}$;

$T(asp) = \text{allowance for signal processing}$.

The additional delay required for IP packet assembly and presentation to the underlying link layer will depend on the link layer. When the link layer is a LAN (e.g. Ethernet), this additional time will usually be quite small. For the purposes of the present document it is assumed that in the test setup this delay can be neglected.

NOTE 1: The size of $T(aif)$ is for further study.

Informative values:

In order to use the formula it is needed to use a table such as provided below (table F.3).

The allowance for signal processing by the encoder should be $T(\text{asp}) < T(\text{ps})$.

NOTE 2: With the knowledge of the codec specific values for $T(\text{fs})$ the values for send delay for any type of coder and any packet size $T(\text{ps})$ can easily be calculated by formula above. Table F.3 provides values calculated accordingly for frequently used codecs and packet sizes.

Table F.3: Example of the composition of the delay values

Codec over air i/f (DECT)	Codec over line i/f (VoIP)	N	T(fs) in ms	T(ps) in ms	T(ead) in ms	T(aif) in ms	T(asp) in ms	T(s) Value in ms
G.722 [14]	G.722 [14]	160	0,0625	10	0	0	10	< 20
		320	0,0625	20	0	0	10	< 30
G.729.1 [17]	G.729.1 [17]	1	20	20	26,97	0	20	< 66,97
MPEG-4 ER ACC-LD [18], [19]	MPEG-4 ER ACC-LD [18], [19]	For further study						

NOTE 3: In the case of G 729.1 with lower rate (down to 8 kbit/s), the value for delay should be identical.

NOTE 4: There may be some extra delay due to optional features.

F.1.2.2 Receive delay

For a VoIP fixed part, receive delay is defined as the one-way delay from the interface to the packet based network of this VoIP terminal to its air interface. The total receive delay is the upper bound on the mean delay and takes into account the delay contributions of all of the elements shown in figure 3 of G.1020 [25] and in figure A.2 of G.1020 [25], respectively.

The receiving delay $T(\text{r})$ is defined as follows:

$$T(\text{r}) = T(\text{fs}) + T(\text{dad}) + T(\text{aif}) + T(\text{jb}) + T(\text{plc}) + T(\text{asp})$$

Where:

$T(\text{fs})$ = frame size of decoder (= frame size of encoder);

$T(\text{aif})$ = air interface framing;

$T(\text{dad})$ = decoder algorithmic delay (filtering,...);

$T(\text{jb})$ = jitter buffer size;

$T(\text{plc})$ = PLC buffer size;

$T(\text{asp})$ = allowance for signal processing.

The additional delay required for IP packet dis-assembly and presentation from the underlying link layer will depend on the link layer. When the link layer is a LAN (e.g. Ethernet), this additional time will usually be quite small. For the purposes of the present document it is assumed that in the test setup this delay can be neglected.

NOTE 1: The size of $T(\text{aif})$ is for further study.

Informative values:

In order to use the formula it is needed to use a table such as provided below (table F.4).

The allowance for signal processing should be $T(\text{asp}) < \max(T(\text{plc}), T(\text{fs}))$.

The additional delay introduced by the jitter buffer should be $T(\text{jb}) \leq 3 * T(\text{ps})$.

For codecs without integrated PLC the additional PLC buffer size should be $T(\text{plc}) < 10$ ms.

For codecs with integrated PLC the additional PLC buffer size should be $T(\text{plc}) = 0$ ms.

NOTE 2: With the knowledge of the codec specific values for $T(fs)$ the values for receive delay for any type of coder and any packet size $T(ps)$ can easily be calculated by formula above. Table F.4 provides values calculated accordingly for some frequently used codecs and packet sizes as an example.

Table F.4: Example of the composition of the delay values

Codec over air i/f (DECT)	Codec over line i/f (VoIP)	N	T(fs) in ms	T(dad) in ms	T(aif) in ms	T(jb) in ms	T(plc) in ms	T(asp) in ms	T(r) Value in ms
G.722 [14]	G.722 [14]	160	0,0625	0	0	< 30	10	10	< 50,0625
		320	0,0625	0	0	< 60	10	10	< 80,0625
G.729.1 [17]	G.729.1 [17]	1	20	1,97	0	< 60	0	20	< 101,97
MPEG-4 ER ACC-LD [18], [19]	MPEG-4 ER ACC-LD [18], [19]	For further study							

$T(ps) = \text{packet size} = N * T(fs)$.

N = number of frames per packet.

NOTE 3: These values are based on the lowest possible delay values which can be expected under ideal network conditions. Caution must be exercised to ensure that the terminal is operated under optimum conditions in order to avoid adverse effects, e.g. network conditions, settings and memory effects of the terminal jitter buffer.

NOTE 4: There may be some extra delay due to optional features.

Annex G (informative): Bibliography

- ETSI TR 101 310: "Digital Enhanced Cordless Telecommunications (DECT); Traffic capacity and spectrum requirements for multi-system and multi-service DECT applications co-existing in a common frequency band".
- ETSI EN 300 444: "Digital Enhanced Cordless Telecommunications (DECT); Generic Access Profile (GAP)".
- ITU-T Recommendation I.241 (1988): "Teleservices supported by an ISDN".
- ISO 3 (1973): "Preferred numbers - Series of preferred numbers".
- ITU-T Recommendation G.122: "Influence of national systems on stability and talker echo in international connections".
- ETSI TR 102 648-1: "Speech Processing, Transmission and Quality Aspects (STQ); Test Methodologies for ETSI Test Events and Results; Part 1: VoIP Speech Quality Testing".
- ETSI EG 202 425: "Speech Processing, Transmission and Quality Aspects (STQ); Definition and implementation of VoIP reference point".
- ETSI EG 202 518: "Speech Processing, Transmission and Quality Aspects (STQ); Acoustic Output of Terminal Equipment; Maximum Levels and Test Methodology for Various Applications".
- ITU-T Recommendation P.341 (2005): "Transmission characteristics for wideband (150-7000 Hz) digital hands free telephony terminals".

Annex H (informative): Change history

The following table presents main changes from a published version to the next version (published or to be published).

Subject/Comment	Old	New
The enhancement of the DECT base standard to support higher data rates includes the 16 QAM/64 QAM modulation option and the Channel Coding based on the Turbo Code Principle.	1.6.1	1.7.1
No changes - just compatible versions alignment with the other parts.	1.7.1	1.8.1
Aligned with the ITU-T Recommendations to use Equipment Impairment Factor according to the E-Model instead of Quantization distortion and the new more flexible application rules for echo cancelling. Also the sending and receiving loudness rating of the portable part have been aligned with other standards for wireless terminals.	1.8.1	1.9.1
New Generation DECT: A major review of the DECT base standard introducing wideband speech, improved data services, new slot types and other technical enhancements.	1.9.1	2.1.1
Major review of the audio specifications introducing the following improvements: 1) definition of different audio models for different PPs and FPs applications; 2) more detailed technical specification for all types; 3) improvement in TCLw parameter taking into account the increasing use of VoIP in networks; 4) introduction of HATS defined audio specifications; 5) introduction of audio specification for handsfree (loudspeaking) devices; 6) new echo cancellation strategy in FPs; 7) Informative annex describing the echo scenarios and subjective effects depending on network delays and terminal TCLw. This major review has been performed in a back-compatible way, by keeping existing (V2.1.1) specifications as specific types: type 1a (classic DECT narrowband PP specification) and 2a (wideband PP specification introduced in V2.1.1) for PPs and types 1a (FP with ISDN interface) and 2 (FP with analog 2-wire interface) for FPs.	2.1.1	2.2.1

History

Document history			
Edition 1	October 1992	Publication as ETS 300 175-8 (Historical)	
Edition 2	September 1996	Publication as ETS 300 175-8 (Historical)	
V1.4.2	June 1999	Publication	
V1.5.1	February 2001	Publication	
V1.6.1	January 2002	Publication	
V1.7.1	July 2003	Publication	
V1.8.1	November 2004	Publication	
V1.9.1	September 2005	Publication	
V2.1.1	August 2007	Publication	
V2.1.2	June 2008	Public Enquiry	PE 20081017: 2008-06-18 to 2008-10-17
V2.2.0	November 2008	Vote	V 20090121: 2008-11-22 to 2009-01-21
V2.2.1	February 2009	Publication	