

ETSI EN 300 175-8 V1.5.1 (2001-02)

European Standard (Telecommunications series)

Digital Enhanced Cordless Telecommunications (DECT); Common Interface (CI); Part 8: Speech coding and transmission



Reference

REN/DECT-000157-8

Keywords

DECT, radio, speech

ETSI

650 Route des Lucioles
F-06921 Sophia Antipolis Cedex - FRANCE

Tel.: +33 4 92 94 42 00 Fax: +33 4 93 65 47 16

Siret N° 348 623 562 00017 - NAF 742 C
Association à but non lucratif enregistrée à la
Sous-Préfecture de Grasse (06) N° 7803/88

Important notice

Individual copies of the present document can be downloaded from:

<http://www.etsi.org>

The present document may be made available in more than one electronic version or in print. In any case of existing or perceived difference in contents between such versions, the reference version is the Portable Document Format (PDF). In case of dispute, the reference shall be the printing on ETSI printers of the PDF version kept on a specific network drive within ETSI Secretariat.

Users of the present document should be aware that the document may be subject to revision or change of status. Information on the current status of this and other ETSI documents is available at <http://www.etsi.org/tb/status/>

If you find errors in the present document, send your comment to:
editor@etsi.fr

Copyright Notification

No part may be reproduced except as authorized by written permission.
The copyright and the foregoing restriction extend to reproduction in all media.

© European Telecommunications Standards Institute 2001.
All rights reserved.

Contents

Intellectual Property Rights	6
Foreword.....	6
1 Scope.....	7
2 References.....	7
3 Definitions and abbreviations.....	8
3.1 Definitions.....	8
3.2 Abbreviations.....	9
4 Configurations.....	10
4.1 Reference configuration.....	10
4.1.1 Basic configuration.....	10
4.1.2 Portable Part (PP).....	11
4.1.2.1 Functional organization.....	11
4.1.2.2 Volume control.....	12
4.1.3 Fixed Part (FP).....	12
4.1.3.1 Digital interface.....	12
4.1.3.2 Analogue interface.....	13
4.1.3.3 FP adaptive volume control.....	13
4.2 Test configurations.....	13
5 Encoding.....	13
5.1 32 kbit/s full term (ADPCM).....	13
5.1.1 Algorithm.....	13
5.1.2 Bit sequence.....	14
5.2 Other codings.....	14
6 Transmission aspects.....	14
6.1 Relative level.....	14
6.2 Acoustic reference level.....	14
6.3 Volume control.....	14
7 Speech performance characteristics.....	15
7.1 PP frequency responses.....	15
7.1.1 Sending.....	15
7.1.2 Receiving.....	15
7.2 PP sending and receiving loudness ratings.....	15
7.2.1 Nominal values.....	15
7.2.2 User-controlled volume control in PP.....	16
7.2.3 PP adaptive volume control.....	16
7.2.4 FP adaptive volume control.....	17
7.3 Sidetone.....	17
7.3.1 Talker sidetone.....	17
7.3.2 Listener sidetone.....	17
7.4 Terminal coupling loss.....	18
7.4.1 Weighted Terminal Coupling Loss (TLC _w).....	18
7.4.1.1 PP for the 3,1 kHz service (PSTN or ISDN).....	18
7.4.1.2 FP with 4-wire interface.....	18
7.4.1.3 FP with analogue 2-wire interface.....	19
7.4.1.4 PP for unrestricted 64 kbit/s service.....	19
7.4.2 Stability loss.....	19
7.4.2.1 Requirement.....	19
7.4.2.2 Test conditions.....	19
7.4.2.3 Fixed geometry PP.....	19
7.4.2.4 Variable geometry PP.....	19
7.5 Distortion.....	19
7.5.1 Sending.....	19

7.5.2	Receiving.....	19
7.5.3	Sidetone.....	20
7.5.4	Recommended value for network planning.....	20
7.6	Out of band signals.....	20
7.6.1	Sending (discrimination against out of band input signals).....	20
7.6.2	Receiving (spurious out of band signals).....	20
7.7	Noise.....	20
7.7.1	Sending.....	20
7.7.2	Narrow-band noise.....	20
7.7.3	Receiving.....	21
7.7.4	Level of sampling frequency (receiving).....	21
7.8	Acoustic shock.....	21
7.8.1	Continuous signal.....	21
7.8.2	Peak signal.....	21
7.9	Delay.....	21
7.9.1	DECT network.....	21
7.9.2	PP.....	21
7.9.3	FP.....	21
7.10	Network echo control.....	22
7.11	PP ambient noise rejection.....	22
7.12	Additional requirements for DECT systems provided with a 2-wire PSTN interface.....	22
7.12.1	General.....	23
7.12.1.1	Polarity independence.....	23
7.12.1.2	Feed Conditions.....	23
7.12.1.3	Power supply.....	23
7.12.2	Speech performance characteristics.....	23
7.12.2.1	Sensitivity/frequency response.....	23
7.12.2.2	Sending and Receiving Loudness Ratings (SLR and RLR).....	23
7.12.2.3	Distortion.....	23
7.12.2.4	Noise.....	24
7.12.2.5	Echo Return Loss.....	24
8	Additional features.....	24
8.1	Loudspeaking and hand-free facilities.....	24
8.2	Tandem with mobile radio network.....	24
8.2.1	Tandem with GSM.....	24
8.2.1.1	Network echo control.....	24
8.2.1.2	Terminal coupling loss.....	25
8.2.1.3	The GSM mobile transmitter operates in continuous mode.....	25
8.2.1.4	The GSM mobile transmitter operates in discontinuous mode, DTX.....	25
8.3	DECT connected to the GSM fixed network.....	25
8.3.1	Network echo control.....	25
8.3.2	Terminal coupling loss.....	25
8.4	Wireless Relay Stations (WRS).....	26
8.4.1	Modified FP network echo control requirements for implementation of 2 and 3 CRFP links in cascade.....	26
Annex A (informative): Description of "reference" echo control devices.....		27
A.1	Handset echo.....	27
A.1.1	Overview.....	27
A.1.1.1	Connection to the PSTN/ISDN.....	27
A.1.1.1.1	Local and national calls.....	27
A.1.1.1.2	Long distance connections with echo control devices in the PSTN/ISDN, e.g. calls via satellites.....	27
A.1.1.2	Connection to the GSM network.....	28
A.1.2	Implementation of the FP echo control function.....	28
A.1.2.1	Suppression threshold.....	29
A.1.2.2	Static characteristics of activation control.....	29
A.1.2.3	Dynamic characteristics of activation control.....	29
A.2	Network echo.....	30
A.2.1	Soft suppressor implementation of requirement 2.....	30
A.2.1.1	Static characteristics.....	31

A.2.1.2	Dynamic characteristics	31
A.2.2	Additional echo control for a 2-wire interface of requirement 1	31
A.2.3	Echo canceller used for both requirements 1 and 2.....	32
Annex B (informative):	Local loop application.....	33
B.1	DECT tethered local loop replacement with 2-wire PP end system	33
B.1.1	TCLw requirements.....	33
B.1.2	Network echo.....	34
B.2	Quantization distortion considerations.....	34
Annex C (informative):	GSM Discontinuous Transmission (DTX), and Voice Activity Detection (VAD).....	35
Annex D (informative):	Speech levels in relation to ambient room noise and examples of adaptive volume control settings	36
Annex E (informative):	Bibliography.....	37
History		38

Intellectual Property Rights

IPRs essential or potentially essential to the present document may have been declared to ETSI. The information pertaining to these essential IPRs, if any, is publicly available for **ETSI members and non-members**, and can be found in ETSI SR 000 314: "*Intellectual Property Rights (IPRs); Essential, or potentially Essential, IPRs notified to ETSI in respect of ETSI standards*", which is available from the ETSI Secretariat. Latest updates are available on the ETSI Web server (<http://www.etsi.org/ipr>).

Pursuant to the ETSI IPR Policy, no investigation, including IPR searches, has been carried out by ETSI. No guarantee can be given as to the existence of other IPRs not referenced in ETSI SR 000 314 (or the updates on the ETSI Web server) which are, or may be, or may become, essential to the present document.

Foreword

This European Standard (Telecommunications series) has been produced by ETSI Project Digital Enhanced Cordless Telecommunications (DECT).

The present document is part 8 of a multi-part EN covering the Common Interface (CI) for the Digital Enhanced Cordless Telecommunications (DECT), as identified below:

- Part 1: "Overview";
- Part 2: "Physical Layer (PHL)";
- Part 3: "Medium Access Control (MAC) layer";
- Part 4: "Data Link Control (DLC) layer";
- Part 5: "Network (NWK) layer";
- Part 6: "Identities and addressing";
- Part 7: "Security features";
- Part 8: "Speech coding and transmission".**

Further details of the DECT system may be found in TR 101 178 [18] and ETR 043 [19].

National transposition dates	
Date of adoption of this EN:	16 February 2001
Date of latest announcement of this EN (doa):	31 May 2001
Date of latest publication of new National Standard or endorsement of this EN (dop/e):	30 November 2001
Date of withdrawal of any conflicting National Standard (dow):	30 November 2001

1 Scope

The present document gives an introduction and overview of the complete Digital Enhanced Cordless Telecommunications (DECT) Common Interface (CI).

This part of the DECT CI specifies the speech coding and transmission requirements.

In order to ensure satisfactory interworking of different portable and fixed units, it is necessary to specify the transmission performance of the analogue information over the digital link. This requires not only use of a common speech algorithm, but also standardization of frequency responses, reference speech levels (or loudness) at the air interface and various other parameters.

The present document applies to DECT equipment which includes all the necessary functions to provide real-time two-way speech conversation. A 3,1 kHz telephony teleservice conveyed over a DECT link (including Fixed Part (FP) and Portable Part (PP)) which is capable of being connected (directly or indirectly) to the public network access point has to comply with the requirements in the present document.

Tethered fixed point local loop applications are not required to comply with the requirements of the present document.

The speech performance characteristics defined in the present document typically conform to TBR 8 [13], which specifies the overall performance between the handset acoustic interface and a 64 kbit/s A-law Pulse Code Modulated (PCM) digital network interface. The deviations from TBR 8 [13] are mainly due to the consequences of non-PCM coding and transmission delay.

The additional features described in clause 8 are those which are not included in TBR 8 [13], but which are likely to occur in a DECT system: analogue interface, loudspeaking and hand-free facilities, tandeming with a mobile radio network. Headsets are not covered by the present specifications.

For the DECT systems which connect to the Public Switched Telephone Network (PSTN) via an analogue interface, the additional requirements, which have to be implemented in the FP, have as much as possible been aligned with TBR 38 [17].

ETSI/STC TM5 has prepared a technical report, ETR 041 [20], to be used as a guide for network planning.

A summary of the control and the use of the DECT echo control functions, to guide on need for options to manufacturers and installers, is found in annex A.

Information concerning test methods can be found in EN 300 176 [3]. The test methods take into account that DECT is a digital system.

2 References

The following documents contain provisions which, through reference in this text, constitute provisions of the present document.

- References are either specific (identified by date of publication, edition number, version number, etc.) or non-specific.
- For a specific reference, subsequent revisions do not apply.
- For a non-specific reference, the latest version applies.

[1] ETSI EN 300 175-1: "Digital Enhanced Cordless Telecommunications (DECT); Common Interface (CI); Part 1: Overview".

[2] ETSI EN 300 175-5: "Digital Enhanced Cordless Telecommunications (DECT); Common Interface (CI); Part 5: Network (NWK) layer".

[3] ETSI EN 300 176 (all parts): "Digital Enhanced Cordless Telecommunications (DECT); Approval test specification".

- [4] ITU-T Recommendation G.101 (1996): "The transmission plan".
- [5] ITU-T Recommendation G.131 (1996): "Control of talker echo".
- [6] ITU-T Recommendation G.164 (1988): "Echo suppressors".
- [7] ITU-T Recommendation G.165 (1993): "Echo cancellers".
- [8] ITU-T Recommendation G.701 (1993): "Vocabulary of digital transmission and multiplexing, and pulse code modulation (PCM) terms".
- [9] ITU-T Recommendation G.726 (1990): "40, 32, 24, 16 kbit/s Adaptive Differential Pulse Code Modulation (ADPCM)".
- [10] ITU-T Recommendation I.241 (1988): "Teleservices supported by an ISDN".
- [11] ITU-T Recommendation P.10 (1993): "Vocabulary of terms on telephone transmission quality and telephone sets".
- [12] ITU-T Recommendation P.340 (1996): "Transmission characteristics of hands-free telephones".
- [13] ETSI TBR 008 (1998): "Integrated Services Digital Network (ISDN); Telephony 3,1 kHz telesevice; Attachment requirements for handset terminals".
- [14] ITU-T Recommendation G.113 (1996): "Transmission impairments".
- [15] ITU-T Recommendation G.111 (1993): "Loudness ratings (LRs) in an international connection".
- [16] ETSI ETS 300 540: "Digital cellular telecommunications system (Phase 2); Transmission planning aspects of the speech service in the GSM Public Land Mobile Network (PLMN) system (GSM 03.50 version 4.6.1)".
- [17] ETSI TBR 38 (1998): "Public Switched Telephone Network (PSTN); Attachment requirements for a terminal equipment incorporating an analogue handset function capable of supporting the justified case service when connected to the analogue interface of the PSTN in Europe".
- [18] ETSI TR 101 178: "Digital Enhanced Cordless Telecommunications (DECT); A High Level Guide to the DECT Standardization".
- [19] ETSI ETR 043: "Digital Enhanced Cordless Telecommunications (DECT); Common Interface (CI); Services and facilities requirements specification".
- [20] ETSI ETR 041: "Transmission and Multiplexing (TM); Digital European Cordless Telecommunications (DECT); Transmission aspects 3,1 kHz telephony Interworking with other networks".

3 Definitions and abbreviations

3.1 Definitions

For the purposes of the present document, the relevant terms and definitions defined in ITU-T Recommendations P.10 [11], G.701 [8] and the following apply:

Cordless Radio Fixed Part (CRFP): see EN 300 175-1 [1]

double duplex bearer: see EN 300 175-1 [1]

End System (ES): see EN 300 175-1 [1]

fixed geometry Portable Part (PP): see EN 300 175-1 [1]

Fixed Part (DECT Fixed Part) (FP): see EN 300 175-1 [1]

Fixed radio Termination (FT): see EN 300 175-1 [1]

Generic Access Profile (GAP): see EN 300 175-1 [1]

handset echo: see EN 300 175-1 [1]

network (telecommunication network): see EN 300 175-1 [1]

network echo: see EN 300 175-1 [1]

operator (DECT operator): see EN 300 175-1 [1]

Portable Part (DECT Portable Part) (PP): see EN 300 175-1 [1]

Portable radio Termination (PT): see EN 300 175-1 [1]

public: see EN 300 175-1 [1]

public access service: see EN 300 175-1 [1]

Radio Fixed Part (RFP): see EN 300 175-1 [1]

Repeater Part (REP): see EN 300 175-1 [1]

service provider (telecommunications service provider): see EN 300 175-1 [1]

telephony service: see ITU-T Recommendation I.241 [10]

user (of a telecommunication network): see EN 300 175-1 [1]

variable geometry PP: see EN 300 175-1 [1]

Wireless Relay Station (WRS): see EN 300 175-1 [1]

3.2 Abbreviations

For the purposes of the present document, the relevant abbreviations defined in ITU-T Recommendations P.10 [11], G.701 [8] and the following apply:

ADPCM	Adaptive Differential Pulse Code Modulation
CI	Common Interface
CFRP	Cordless Radio Fixed Part
CLRR	Circuit Loudness Rating, Receiving
CLRS	Circuit Loudness Rating, Sending
CRFP	Cordless Radio Fixed Part
dBm	The absolute power level relative to 1 milliwatt, expressed in dB
dBm0	The absolute power level in dBm referred to a point of zero relative level (0 dBr point)
dBm0p	Psophometrically weighted absolute power level expressed in dBm referred to a point of zero relative level (0 dBr point)
dBPa	Sound pressure level relative to 1 Pa, expressed in dB
dBPa(A)	A-weighted sound pressure level relative to 1 Pa, expressed in dB
dBr	The relative power level of a signal in a transmission path referred to the level at a reference point on the path (0 dBr point)
DECT	Digital Enhanced Cordless Telecommunications
ERP	Ear Reference Point
ES	End System
EUT	Equipment Under Test
FP	Fixed Part
FT	Fixed radio Termination ⁷
GAP	Generic Access Profile
ISDN	Integrated Services Digital Network
LLe	Local Echo Loss
LSTR	Listener Sidetone Rating
MRP	Mouth Reference Point
NLP	Non-Linear Processor
NWK	Network

OLR	Overall Loudness Rating
P(A)BX	Private (Automatic) Branch Exchange
PCM	Pulse Code Modulated
PP	Portable Part
PSTN	Public Switched Telephone Network
PT	Portable radio Termination
ReFP	Reference Fixed Part
RePP	Reference Portable Part
REP	REpeater Part
RFP	Radio Fixed Part
RLR _H	Receiving Loudness Rating of the Handset
SLR _H	Sending Loudness Rating of the Handset
TCL _w	weighted Terminal Coupling Loss
TDMA	Time Division Multiple Access
TELR	Talker's Echo Loudness Rating
STMR	Sidetone Masking Rating
QDU	Quantization Distortion Unit
WRS	Wireless Relay Station

4 Configurations

4.1 Reference configuration

4.1.1 Basic configuration

The basic reference configuration for voice transmission over DECT is shown in figure 1.

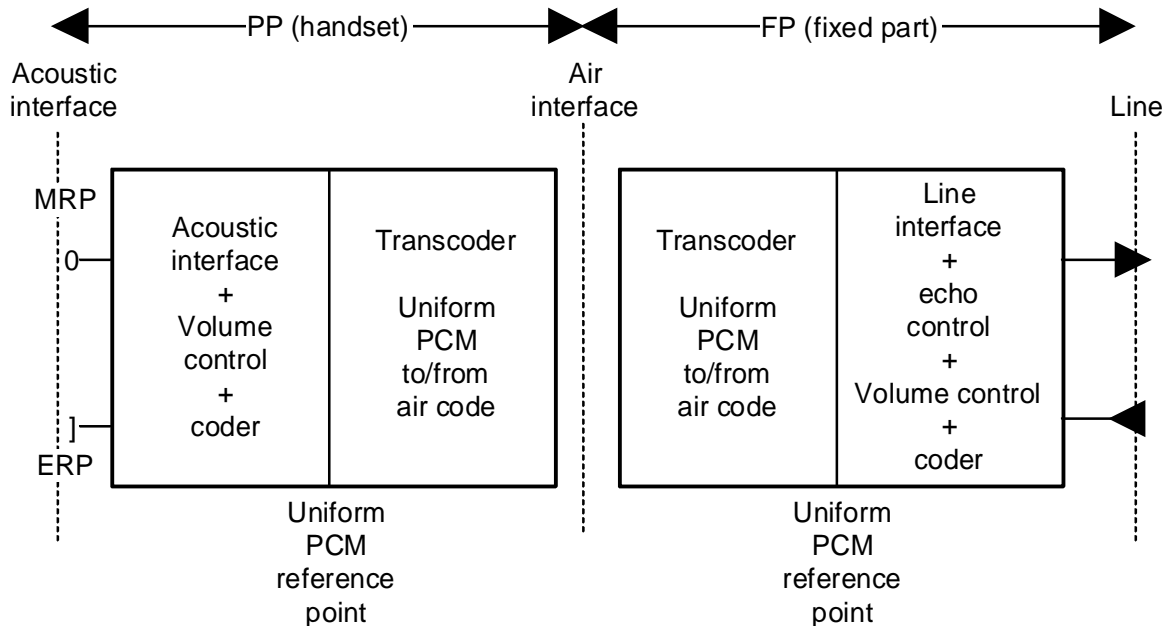

Figure 1: Basic reference configuration

The PP and the FP are delimited by physical interfaces:

- Acoustic: from the PP towards the speaker-listener, with the Ear and Mouth Reference Points (ERP and MRP).
- Air(RF): the interface between PP and FP.
- Line: the interface from the FP towards the network.

Uniform PCM reference points shall be introduced in both the PP and the FP to materialize the limits of the transmission segment which is affected by the air interface coding scheme. This allows the transmission requirements to be specified independently from the coding at the air interface. The various transcoding algorithms are level-transparent, i.e. with an encoder and decoder connected in tandem, the "levels" of the digital signals at the uniform PCM input of the encoder and output from the decoder are identical. In a particular implementation, the reference points may be embedded within an IC, and thus will not be physically accessible.

Each of the three sections thus delimited deals with distinct functions:

- the PP electro-acoustic section (between acoustic interface and PP uniform PCM reference point) which includes the acoustic interface, the volume control and the analogue to digital conversion;
- the air-code section (between PP and FP uniform PCM reference points) considers the transcoding between uniform PCM and the air-code, as well as the transmission over the air interface;
- the FP line interface section (between FP uniform PCM reference point and line interface) comprises the interface to the line, digital or analogue, and the FP voice processing, e.g. echo control.

Typically, the transmission features shall conform to TBR 8 [13] for the PP electro-acoustic section, and the line interface section in the case of digital interface. In the case of analogue interface, the line interface section realizes in the FP the adaptation to clause 7.12 and to the relevant attachment requirements.

4.1.2 Portable Part (PP)

4.1.2.1 Functional organization

Figure 2 represents the basic functional organization of a PP from the voice transmission point of view:

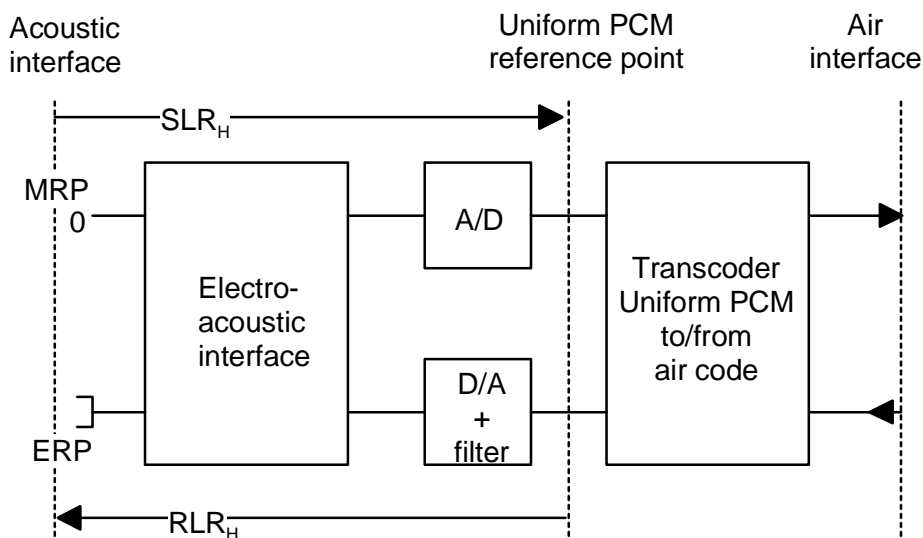

Figure 2: PP functional organization

The various functions represented in figure 2 are:

- the electro-acoustic function, which performs the interface to the transducers and the volume control. The Handset Loudness Ratings (SLR_H) and (RLR_H) are defined between the acoustic interface and the uniform PCM reference point;
- the analogue to digital and digital to analogue coding to the uniform PCM reference point;
- the transcoder between uniform PCM and air-code.

4.1.2.2 Volume control

The volume control facility is optional, and can be implemented in a number of different ways:

- 1) in the simplest implementation, it affects only the receiving level and is under the manual control of the PP user;
- 2) the volume adjustment may also be adaptive, e.g. taking into account the average level of ambient noise at the MRP;
- 3) the volume control may affect both receiving and sending levels in opposite directions. This has the advantage of reducing the influence on the terminal coupling loss when the receive volume is increased. Such an implementation would fit a noisy environment, as the need for an increased receiving volume is likely to come from a loud ambient noise, and it is then combined with a loud speech level.

4.1.3 Fixed Part (FP)

4.1.3.1 Digital interface

Figure 3 shows the functional organization of a FP with a digital interface:

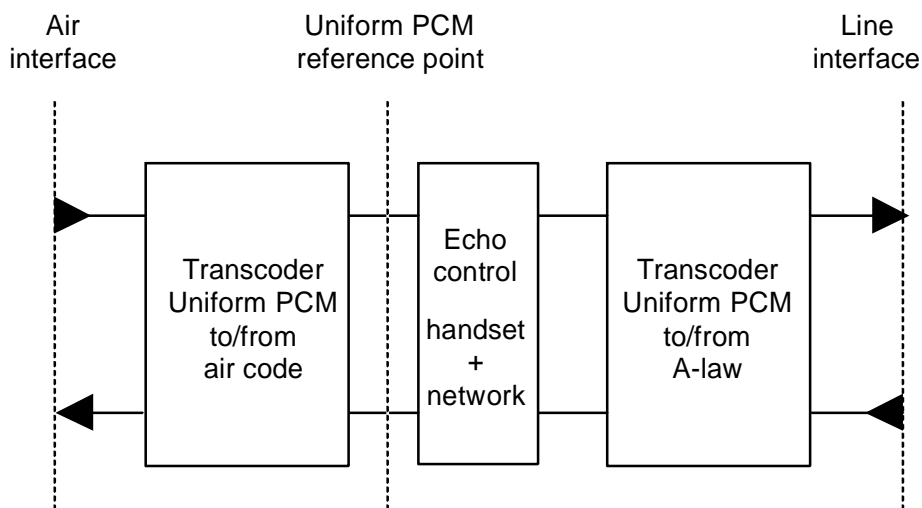

Figure 3: FP functional organization

The various functions represented in figure 3 are:

- a) a transcoder between air-code and uniform PCM;
- b) an echo control function which processes echoes coming back from both the handset and the network. It provides additional losses that compensate for the increased length of the echo path due to the DECT transmission delay over the air interface;
- c) a transcoder from uniform PCM to A-law PCM towards the line interface.

4.1.3.2 Analogue interface

The implementation of a FP with an analogue interface is shown in figure 4.

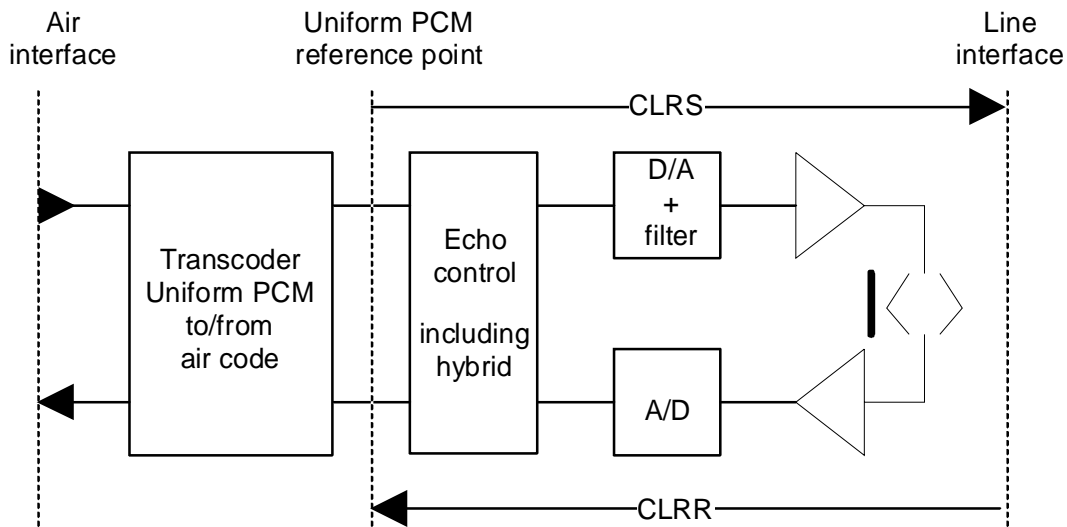

Figure 4: FP with an analogue interface

The various functions represented in figure 4 are:

- a) the line interface comprises the digital to analogue coder-decoder and the adaptation to the line, that can be either 2- or 4-wire. The Circuit Loudness Ratings (CLRR and CLRS) are defined between uniform PCM reference point and the line interface;
- b) in the case of a 2-wire line, the network echo controller deals both with the local hybrid echo and the far end network echo.

4.1.3.3 FP adaptive volume control

An adaptive dual volume adjustment, as described in clause 4.1.2.2, may optionally be implemented into the FP, for base stations where the associated PPs may be used in a noisy environment (e.g. public access).

4.2 Test configurations

A DECT system comprises a FP and a PP. As these parts are not always purchased together, it is a requirement that either the complete system or each of the two separate parts shall be capable of being tested (see EN 300 176 [3]).

5 Encoding

5.1 32 kbit/s full term (ADPCM)

5.1.1 Algorithm

The speech coding algorithm shall conform to ITU-T Recommendation G.726 [9] for 32 kbit/s Adaptive Differential Pulse Code Modulation (ADPCM).

The A-law companding and synchronous tandem adjustment may be omitted in FPs with an analogue line interface and in PPs.

NOTE: ITU-T Recommendation G.726 [9] 32 kbit/s ADPCM codecs support the use of the voice channel for telefax of group 2 and group 3. For group 3 the data speed, which is automatically negotiated, is in practice normally limited to 9,6 kbit/s.

5.1.2 Bit sequence

The ADPCM words comprised in each burst shall be transmitted in chronological order, and with the most significant bit transmitted first within each word.

5.2 Other codings

No other coding scheme is permitted at this time. When introducing a new coding the following speech performance characteristics shall be reviewed:

- frequency response;
- distortion;
- delay; and
- if the latter is widely affected, terminal coupling loss and network echo control.

6 Transmission aspects

6.1 Relative level

The digital line interface is a 0 dBr point according to ITU-T Recommendation G.101 [4]. As the various digital transcoding algorithms are essentially loss-less, the relative level is constant over the whole digital path in the PP and the FP.

6.2 Acoustic reference level

The acoustic reference level is defined as the acoustic level which corresponds to a level of -10 dBm₀ at the digital interface.

6.3 Volume control

Unless stated otherwise, if a user-controlled volume control is provided at the PP, the requirements apply for all positions of the volume control, and the compliance tests shall be carried out at the maximum setting of this volume control.

NOTE: The testing of a PP with a dual or an adaptive volume control requires further study.

7 Speech performance characteristics

7.1 PP frequency responses

7.1.1 Sending

The sending sensitivity-frequency response (from MRP to the digital interface) shall be within a mask as defined in table 1.

Table 1: Sending sensitivity-frequency mask

Frequency (Hz)	Upper limit (dB)	Lower limit (dB)
100	- 9	
200	0	
300	0	- 14
800	0	-10
2 000	4	- 8
3 400	4	- 11
4 000	4	
8 000	-13	

NOTE 1: The limits at intermediate frequencies lie on a straight line drawn between the given values on a log (frequency) - linear (dB) scale.
NOTE 2: All dB levels are on an arbitrary scale.

7.1.2 Receiving

The receiving sensitivity-frequency response (from the digital interface to the ERP) shall be within a mask as defined in table 2.

Table 2: Receiving sensitivity-frequency mask

Frequency (Hz)	Upper limit (dB)	Lower limit (dB)
100	- 10	
200	2	
300	2	- 9
1 000	2	- 7
3 400	2	- 12
4 000	2	
8 000	-15	

NOTE 1: The limits at intermediate frequencies lie on a straight line drawn between the given values on a log (frequency) - linear (dB) scale.
NOTE 2: All dB levels are on an arbitrary scale.

7.2 PP sending and receiving loudness ratings

7.2.1 Nominal values

The nominal values are:

Sending Loudness Rating (SLR_H) = 7 dB; and

Receiving Loudness Rating (RLR_H) = 3 dB.

There is a manufacturing tolerance of $\pm 3,5$ dB on both RLR_H and SLR_H .

NOTE: ITU-T test methods on loudness ratings are valid only for codecs that can transmit sinusoids without excessive distortion.

7.2.2 User-controlled volume control in PP

A user-controlled volume control shall be provided in all PP equipment, except where an adaptive volume control is incorporated in the PP.

When adjusting the volume control from nominal setting (where RLR_H is closest to its nominal value) to maximum setting, the decrease in RLR_H shall be not less than 6 dB.

A user-controlled volume control can be implemented either as a receiving volume control (where RLR_H is changed) or as a "joint-acting volume control (where SLR_H and RLR_H are simultaneously changed in opposite directions). For both types of volume control RLR_H and SLR_H shall simultaneously meet the values given in clause 7.2.1 (including the tolerances) for at least one setting of the volume control.

The RLR_H and SLR_H shall not exceed the limits given in tables 3 and 4.

Table 3: Absolute limits for "joint-acting" volume control

Volume setting	Maximum	Minimum
RLR_H	- 13 dB	19 dB
SLR_H	17 dB	3 dB

Table 4: Absolute limits for a receiving volume control

Volume setting	Maximum	Minimum
RLR_H	- 13 dB	19 dB

NOTE 1: Minimum setting: The setting where the RLR has its maximum value.

Maximum setting: The setting where the RLR has its minimum value.

NOTE 2: A user-controlled volume control should include an automatic reset function that ensures that the default setting for each new call is no louder than the nominal setting.

NOTE 3: The basic DECT requirements (echo control, signal levels for A/D converters etc.) are optimized for digital (ISDN) transmission characteristics. Analogue networks [17] require higher receive levels (lower RLR) than digital networks (ISDN). This is to compensate for old long lossy analogue lines that still exist in many PSTNs. Most of the calls do not have lossy lines. Analogue transmissions over a modern network (from equipment using TBR 38 [17] values of SLR and RLR) will thus often provide higher receive levels than a digital (ISDN) connection would. This gives an interworking problem between analogue networks and terminals that use digital codecs as in DECT systems and ISDN terminals, which could cause distortion in the A/D converters and also lower the margin for the wanted terminal echo loss. Therefore, noting that DECT PPs have a volume control with at least 6 dB gain to compensate for lossy connections, it should be allowed to design DECT FP equipment with a receive gain providing typical 4 to 6 dB higher nominal RLR (for FP + PP) than specified in relevant attachment requirements to the PSTN [17]. See clause 7.12.2.2. Some administrations have already implemented this principle.

7.2.3 PP adaptive volume control

The PP shall inform the FP if an adaptive volume control is implemented in the PP. Clause 7.7.41 in EN 300 175-5 [2] describes how this shall be done.

This function is for further study and may follow GSM, or other, specifications when available.

7.2.4 FP adaptive volume control

An adaptive volume control, depending on the level of environmental noise at the PP, may be implemented into the FP. The gain variation shall be symmetrical, i.e. the increase in the receiving direction shall be equal to the decrease in the sending direction.

If the PP adaptive volume control feature is implemented then the FP adaptive volume control feature shall be disabled.

NOTE 1: The PP ambient noise level is calculated in the FP based upon the minimum ambient noise rejection requirement as specified in clause 7.11.

NOTE 2: For an FP with an analogue interface, problems of saturation may occur depending on national RLR values.

See annex D for further information.

7.3 Sidetone

7.3.1 Talker sidetone

The sidetone path shall be implemented in the PP.

The nominal value of the Sidetone Masking Rating (STMR) shall be 13 dB. There is a manufacturing tolerance of -3 dB to +5 dB. The requirement shall be met with SLR_H and RLR_H corrected to the nominal values of SLR_H and RLR_H .

NOTE: It is recommended that the sidetone level is independent of the receiving volume control.

7.3.2 Listener sidetone

There are no mandatory requirements on Listener Sidetone Rating, LSTR and the weighted average D.

NOTE 1: It is recommended that the value of the LSTR is not less than 10 dB referred to the nominal values of SLR_H and RLR_H .

Alternatively it is recommended that the value of the weighted average D of the difference of the send sensitivities between diffuse and direct sound should be measured and should not be less than -5 dB.

For PPs with noise rejection capability as declared by the applicant, the value of the LSTR shall not be less than 15 dB referred to the nominal values of SLR_H and RLR_H . Alternatively the value of the weighted average D of the difference of the send sensitivities between diffuse and direct sound shall be measured and shall not be less than +0 dB.

NOTE 2: The noise rejection capability option is recommended for PPs used in noisy environments.

PPs with declared noise rejection capability option shall indicate this to the FP before or at call set-up by including this information in the <<TERMINAL CAPABILITY>> information element. See EN 300 175-5 [2] clause 7.7.41.

7.4 Terminal coupling loss

The PP shall be suspended in free air.

7.4.1 Weighted Terminal Coupling Loss (TCLw)

7.4.1.1 PP for the 3,1 kHz service (PSTN or ISDN)

For a PP that is designed to provide the 3,1 kHz service, either on ISDN or PSTN, the weighted Terminal Coupling Loss (TCLw) defined from the PP digital input to the PP digital output shall meet one of the following options:

- a) $TCLw > 46$ dB at nominal setting of the volume control corrected to the nominal values of RLR_H and SLR_H . For all positions of volume control the TCLw shall not be less than 35 dB.

NOTE 1: This is the recommended option.

- b) $TCLw > 34$ dB.

NOTE 2: Since there is no statement for option b) on volume control settings, the conditions in 6.3 apply.

If the PP is of type a) then it shall send this information "Full TCL" to the FP as defined in EN 300 175-5 [2], clause 7.7.41 before or at call set-up.

If the FP receives no information concerning the TCLw value of the PP, the FP shall default to the assumption that the PP is of type b).

7.4.1.2 FP with 4-wire interface

The FP echo control functions described below shall be connected or disabled depending on a message from the PP or depending on call routing information and on type of service. It is recommended to disable them when it is known that the one-way delay of the connection is less than 25 ms excluding the DECT delay (e.g. internal Private Automatic Branch eXchange (PABX) connections). They may be disabled if the PP has $TCLw > 46$ dB.

A FP with a 4-wire interface (analogue or digital) shall meet at least one of the two following requirements:

- a) artificial echo loss:
- an artificial echo path shall be implemented into the FP between the line input and the line output, as shown in figure 5. The loss of that echo path shall be $24 \text{ dB} \pm 2 \text{ dB}$.

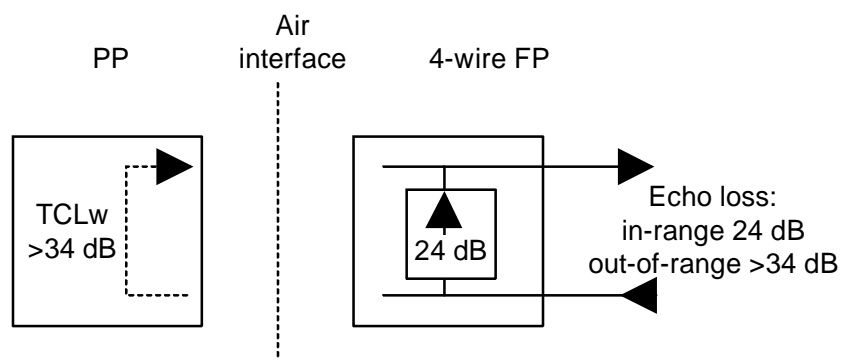

NOTE: The artificial echo simulates the echo from a very good analog 2-wire telephone. When a public network operator uses an echo canceller in the network (e.g. for a satellite link), the artificial echo loss path provides an in-range echo to ensure that the echo canceller and its Non-Linear Processor (NLP) is active. The NLP cancels the 34 dB DECT handset echo. See annex A, clause A.1.1. In some countries the echo cancellers in the public network do not depend on the artificial echo path to activate the NLP. Installations in such countries could have the artificial echo path permanently disabled.

Figure 5: Artificial echo path in a 4-wire FP

b) echo control device:

- an echo control device shall be implemented into the FP. The weighted Terminal Coupling Loss (TCLw) of the DECT system, defined from the FP line input to the FP line output, shall be at least 46 dB.

NOTE 1: Option a) is the option normally used for connections to the PSTN/ISDN. Option b) is needed, e.g. for tandem connection with GSM, clauses 8.2.1 and 8.3.2. Clause A.1.2 provides, for guidance and illustration, the description of a NLP implementation of option b). The control range for an echo canceller and hangover time for an NLP should be greater than or equal to 40 ms. A soft suppressor implementation is not recommended.

NOTE 2: The connect/disable function for options a) and b) is required for approval testing under EN 300 176 [3]. Messages from the PP with control information are defined in EN 300 175-5 [2] clause 7.7.16.

7.4.1.3 FP with analogue 2-wire interface

There is no specific requirement on a FP with an analogue 2-wire interface to the PSTN/ISDN, except those specified in clause 7.12.

7.4.1.4 PP for unrestricted 64 kbit/s service

The unrestricted 64 kbit/s service is outside the scope of the present document.

7.4.2 Stability loss

7.4.2.1 Requirement

In the test conditions described below the attenuation from the digital input to the digital output shall be at least 6 dB at all frequencies in the range of 200 Hz to 4 000 Hz.

7.4.2.2 Test conditions

7.4.2.3 Fixed geometry PP

The handset shall be lying on, and the transducers facing, a hard surface.

7.4.2.4 Variable geometry PP

The equipment shall be capable of meeting the requirement in at least one of the two following conditions:

- a) if it is possible to position the earpiece in front of the mouthpiece with a distance of 150 mm between the front planes of each, the requirement shall be met in this relative position and in the just off-hook position;
- b) if the relative movement and orientation of the acoustic and electro-magnetic elements are limited by means of a hinge or similar mechanism, the requirement shall be met in any relative position and orientation that can be achieved whilst the PP is in active condition, i.e. a communication is established over the air interface.

7.5 Distortion

7.5.1 Sending

The ratio of signal to total distortion (harmonic and quantizing) measured at the line interface shall not be less than 35 dB.

7.5.2 Receiving

The ratio of signal to total distortion (harmonic and quantizing) measured at the ERP shall not be less than 33 dB.

7.5.3 Sidetone

The third harmonic distortion generated by the PP shall not be greater than 10 %.

7.5.4 Recommended value for network planning

According to ITU-T Recommendation G.113 [14], the PCM-to-ADPCM-to-PCM transcoding introduces 2,5 QDU (Quantizing Distortion Units). Therefore, the following values shall be taken into account for network planning purpose:

- 3 QDU if the FP interfaces to a digital line, or 3,5 QDU if the FP interfaces to an analogue line. For further information see ETR 041 [20].

7.6 Out of band signals

7.6.1 Sending (discrimination against out of band input signals)

With any sine-wave signal above 4,6 kHz and up to 8 kHz applied at the MRP at a level of -4,7 dBPa, the level of any image frequency produced at the digital interface shall be below a reference level obtained at 1 kHz (- 4,7 dBPa at MRP) by at least the amount in dB specified in table 5.

Table 5: Discrimination levels - sending

Applied sine wave frequency	Limit (minimum)
4,6 kHz	30 dB
8,0 kHz	40 dB

The limits at intermediate frequencies lie on a straight line drawn between the given values on a log (frequency) - linear (dB) scale.

7.6.2 Receiving (spurious out of band signals)

With a digitally-simulated sine-wave signal in the frequency range of 300 Hz to 3 400 Hz at a level of -10 dBm0 applied at the digital interface, the level of spurious out-of-band image signals in the frequency range of 4,6 kHz to 8 kHz measured selectively at the ERP shall be lower than the in-band acoustic level produced by a digital signal at 1 kHz set at the level specified in table 6.

Table 6: Discrimination levels - receiving

Image signal frequency	Equivalent input level
4,6 kHz	-35 dBm0
8,0 kHz	-45 dBm0

The limits at intermediate frequencies lie on a straight line drawn between the given values on a log (frequency) - linear (dB) scale.

7.7 Noise

7.7.1 Sending

The noise produced by the apparatus in the sending direction shall not exceed -64 dBm0.

7.7.2 Narrow-band noise

The narrow-band noise (due to TDMA) produced by the apparatus in the sending direction, and contained within any 10 Hz bandwidth between the frequency limits 300 Hz to 3 400 Hz, shall not exceed -73 dBm0.

7.7.3 Receiving

If no user-controlled receiving volume control is provided, or if it is provided, at the setting where the RLR_H is equal to the nominal value, the noise produced by the apparatus and measured at the ERP shall not exceed -54 dBPa (A).

7.7.4 Level of sampling frequency (receiving)

The level of the 8 kHz measured selectively at the ERP shall be less than -70 dBPa.

7.8 Acoustic shock

7.8.1 Continuous signal

With a digitally encoded signal representing the maximum possible signal level at the digital interface, the sound pressure level at the ERP shall not exceed 24 dBPa (rms unweighted).

7.8.2 Peak signal

The receiving equipment shall limit the peak sound pressure at the ERP to less than 36 dBPa under any continuous or transient condition.

7.9 Delay

7.9.1 DECT network

The sum of the delays from the MRP to the digital line interface and from the digital line interface to the ERP (round-trip delay) shall not exceed 28,5 ms. If an analogue line interface is provided, the delay shall not exceed 29 ms including the A/D and D/A converters at the interface to the external network.

7.9.2 PP

The sum of the delays from the MRP to the air interface and from the air interface to the ERP (round-trip delay) shall not exceed 19,5 ms. This value includes the 5 ms delay of the reference FP looping back the ADPCM digital signal towards the PP.

7.9.3 FP

The sum of the delays from the digital line interface to the air interface and from the air interface to the digital line interface (round-trip delay) shall not exceed 20 ms. This value includes the 5 ms delay of the reference PP looping back the ADPCM digital signal towards the FP. If an analogue line interface is provided, the delay shall not exceed 20.5 ms including the A/D and D/A converters at the interface to the external network.

7.10 Network echo control

The network echo shall be controlled by inserting into the receiving speech path of the FP an echo loss meeting the requirements as defined in table 7.

Table 7: Network echo control requirements

Echo path delay (2-way)		
Requirement 1: 0 to 4 ms	TELR	≥ 24 dB
Requirement 2: 0 to 60 ms	Extra echo loss	≥ 9 dB

Requirement 1 applies only to FP with an analogue 2-wire line interface. Requirement 2 applies for both 2-wire and 4-wire line interfaces. If the echo control device in the FP contains a soft suppressor, it is recommended to not suppress more than 12 dB.

The 24 dB TELR limit applies for a PP with nominal values for SLR_H and RLR_H ($SLR_H=7$ dB, $RLR_H=3$ dB) and it corresponds to $LLe = 24-7-3= 14$ dB at the uniform PCM reference point of the FP. This requirement shall be met when the FP is terminated with the three terminating impedances, a, b and c, defined in TBR 38 [17] clause A.2.3. No recommendation is made for any particular implementation of the echo control device. For guidance and illustration, a reference soft suppressor that meets requirement 2 is described in clause A.2.1, and a reference echo canceller that meets requirement 1, is described in clause A.2.2.

Depending on routing information and on type of service, it shall be possible to connect and disable each of the echo control functions which perform the respective requirements 1 and 2.

The echo device implemented to meet requirement 2 may be disabled, or its loss may be reduced, in accordance with optionally available routing information, e.g. connections within a PABX, or a 4-wire connection via the PSTN/ISDN to an ISDN terminal.

NOTE: The connect/disable function for requirements 1 and 2 is required for approval testing (see EN 300 176 [3]). Messages from the PP with control information are defined in EN 300 175-5 [2], clause 7.7.16.

7.11 PP ambient noise rejection

The PP ambient noise rejection performance is defined by the D value as described in ITU-T Recommendation G.111 [15]. The D value is not measured, but a value is required for insertion in the FP adaptive volume control algorithm. The D value is derived from the STMR and LSTR specifications.

The FP adaptive volume control shall use the following values:

D = -3 for PPs without declared noise rejection capability;

D = 2 for PPs with declared noise rejection capability.

7.12 Additional requirements for DECT systems provided with a 2-wire PSTN interface

The following additional requirements and test principles apply for complete systems or for a separate FP, when the DECT FP is provided with a 2-wire PSTN interface.

These additional requirements and test methods are to based on TBR 38 [17] with necessary deviations justified the following:

- Any additional provision to meet these additional requirements shall be accommodated within the FP.
- Mandatory tests already performed at the 4-wire uniform PCM reference point interface.
- Requirements justified by the basic principles of the DECT standard including the digital radio link, the additional delay introduced and the use of small lightweight portable handsets.

When testing a separate FP, the tests shall be carried out on the EUT FP in conjunction with a reference PP, RePP, meeting the applicable speech performance characteristics. The RePP shall have nominal values of SLR_H and RLR_H ($SLR_H=7$ dB, $RLR_H=3$ dB), or else, the acceptance criteria of the requirements below shall be adjusted according to the deviations from nominal values.

When testing a complete DECT system, the user-controlled volume control provided at the PP, shall be set as close as possible to the nominal value of SLR_H and RLR_H , unless otherwise stated.

7.12.1 General

7.12.1.1 Polarity independence

The requirements and associated test methods of clause 4.1.1 of TBR 38 [17] shall apply.

7.12.1.2 Feed Conditions

The requirements and associated test methods of clause 4.1.2 of TBR 38 [17] shall apply.

7.12.1.3 Power supply

The requirements and associated test methods of clause 4.1.3 of TBR 38 [17] shall apply.

7.12.2 Speech performance characteristics

The test laboratory shall perform the tests in such a way, that the results are not affected by the delay in the DECT radio interface, or by improper activation of the DECT echo control functions. The DECT echo control functions may be disabled during the tests.

7.12.2.1 Sensitivity/frequency response

The test methods of clause 4.2.1 of TBR 38 [17] shall apply.

The sensitivity masks from clauses 7.1.1 and 7.1.2 above shall be used.

7.12.2.2 Sending and Receiving Loudness Ratings (SLR and RLR)

The requirements and associated test methods of clause 4.2.2 of TBR 38 [17] shall apply, except that the RLR acceptance criteria shall be -8 dB +7/-4 dB for feeding resistance R_f set to 2 800 Ω , 1 000 Ω and 500 Ω .

NOTE: The basic DECT requirements (echo control, signal levels for A/D converters etc.) are optimized for digital (ISDN) transmission characteristics. Analogue transmissions over a modern network (from equipment using TBR 38 [17] values of SLR and RLR) often provide higher receive levels than a digital (ISDN) connection would. Therefore, noting that DECT PPs have a volume control with at least 6 dB gain, it should be allowed to design DECT FP equipment with a receive gain providing typical nominal RLR around -4 dB. This implies for this example that the gain from the 2-wire interface to the EUT FP uniform PCM reference point interface should be $3\text{dB} - (-4\text{ dB}) = 7\text{ dB}$.

7.12.2.3 Distortion

The requirements and associated test methods of clause 4.2.4 of TBR 38 [17] shall apply, except that the test with input e.m.f. of 0 dBV in clause 4.2.4.2 of TBR 38 [17] shall be deleted.

NOTE: The 0 dBV level is too high and is not applicable to a digital system like DECT.

7.12.2.4 Noise

The requirements and associated test methods of clause 4.2.6 of TBR 38 [17] shall apply, except in the test of clause 4.2.6.1 of TBR 38 [17], where the noise acceptance criteria shall be -60 dBVp for feeding resistance R_f set to $2\ 800\ \Omega$, $1\ 000\ \Omega$ and $500\ \Omega$.

NOTE: The requirement has to be consistent with the requirement of clause 7.7 for a digital system like DECT.

7.12.2.5 Echo Return Loss

The requirements and associated test methods of clause 4.2.8 of TBR 38 [17] shall apply.

8 Additional features

8.1 Loudspeaking and hand-free facilities

Loudspeaking and handsfree telephony may each optionally be provided. Speech performance requirements for these additional facilities are outside the scope of the present document.

If loudspeaking and/or handsfree telephony is implemented in telephony 3,1 kHz terminals, the terminals in handset mode shall fulfil the speech transmission requirements of clause 7.

8.2 Tandem with mobile radio network

A tandem of DECT with a mobile radio network shall provide a radio link between the DECT FP and a network, e.g. the PSTN/ISDN.

A speech path shall be provided by connecting a PCM 0dB_r reference point at the line side of the RFP, with a PCM 0dB_r speech reference point of a mobile radio transceiver.

For tandeming with analogue mobile communication networks, national planning rules shall be applied. Tandeming with GSM is specified in clause 8.2.1.

8.2.1 Tandem with GSM

The FP (see figure 3) is interfaced via its uniform PCM interface point to the 0dB_r PCM X-interface point of a GSM mobile radio. See figure 6.

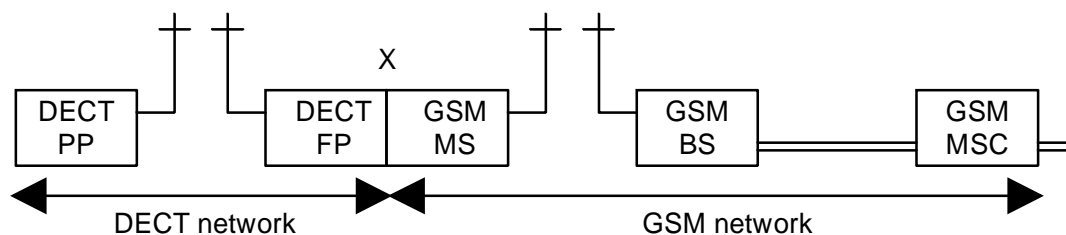

Figure 6: DECT in tandem with the GSM mobile network

8.2.1.1 Network echo control

The network echo control devices inserted in the FP to meet the extra echo loss requirements of clause 7.10 are not required for tandem connections with GSM. If they are implemented in the FP, they shall be disabled.

NOTE: The echo from the GSM network is controlled by the Mobile Switching Centre (MSC) echo canceller in the GSM fixed network, as stated in ETS 300 540 [16] (GSM 03.50).

8.2.1.2 Terminal coupling loss

There are two cases depending upon the mode of the GSM mobile transmitter operation. The mode may change from call to call.

8.2.1.3 The GSM mobile transmitter operates in continuous mode

An echo device shall be implemented at the FP or the GSM side of the PCM reference point. It shall meet the requirements of clause 7.4.1.2 b). If the PP has TCLw 46 dB, the echo device shall be disabled.

8.2.1.4 The GSM mobile transmitter operates in discontinuous mode, DTX

The echo device described in clause 7.4.1.2 shall be disabled.

The GSM mobile transmitter shall not be activated (double-talk state) by a sending speech signal with a level of less than 30 dB below the receiving speech level.

The mobile combination of a DECT FP and a GSM mobile is a specially designed unit. This unit shall meet the 30 dB requirement irrespectively of whether the GSM DTX design itself meets this requirement or not. See annex C for information on GSM, DTX.

8.3 DECT connected to the GSM fixed network

In this application DECT provides a base station sub-system, BSS, to the GSM network. Neither the GSM radio link nor the GSM codec is involved.

The FP, figure 3, is interfaced via its uniform PCM interface point to the 0dB PCM A-interface point of a GSM Network (MSC). See figure 7.

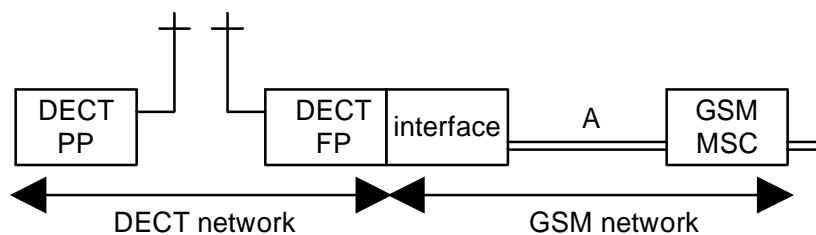

Figure 7: DECT in tandem with the GSM fixed network

8.3.1 Network echo control

The network echo devices inserted in the FP to meet the extra echo loss requirements of clause 7.10 are not required for tandem connections with GSM. If they are implemented in the FP they shall be disabled.

NOTE: The echo from the GSM network is controlled by the Mobile Switching Centre (MSC) echo canceller in the GSM fixed network, as stated in ETS 300 540 [16] (GSM 03.50).

8.3.2 Terminal coupling loss

An echo device shall be implemented at the FP or the GSM side of the PCM reference point. It shall meet the requirements of clause 7.4.1.2 b). The echo device may be disabled in accordance with optionally available routing information. If the PP has TCLw 46 dB, the echo device shall be disabled.

8.4 Wireless Relay Stations (WRS)

The connection between the FT and the WRS is wireless via the closest RFP. A WRS is locked to the closest RFP, or closest WRS when cascading WRSs is allowed. An RFP and a WRS, appear equal to a PP. See figure 8.

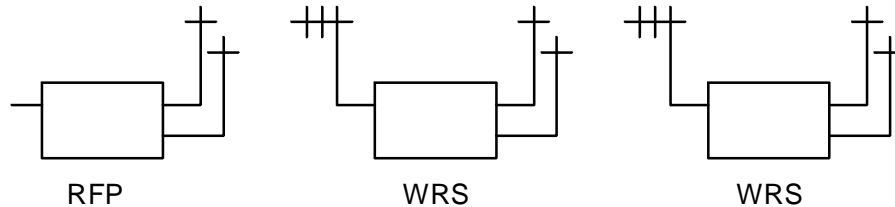

NOTE: A WRS is locked to the closest RFP, or closest WRS when cascaded WRSs are allowed. An RFP and WRS, appear equal to a PP.

Figure 8: FT connection to WRSs

Due to the wireless link, a PP connection to a WRS introduces an incremental delay in relation to a connection to an RFP. The incremental average 1-way delay for speech is 5 ms per cascaded CRFP and maximum 2,5 ms for any chain of cascaded REPs.

This incremental delay causes no fundamental limitation for the speech services.

The DECT speech quality requirements are met with the general DECT echo control requirements for the cases: one CRFP link and any chain of cascaded REP links.

NOTE 1: Compared to an RFP, a WRS may introduce capacity restrictions and higher blocking rate to the services offered. The restrictions may increase with the number of cascaded WRS links, especially for REPs. This will in practice limit a REP chain to three links.

When 2 or 3 CRFP links are cascaded, the FP network echo control requirements (see clause 7.10) may need to be modified depending on the characteristics of the specific network to which the FP is connected. See below.

8.4.1 Modified FP network echo control requirements for implementation of 2 and 3 CRFP links in cascade

These modifications refer to Requirement 1 and Requirement 2 of clause 7.10.

Number of cascaded CRFP links:	2	3
Req. 1- 0-4 ms TELR:	> 27 dB	> 29 dB
Req. 2- 4-60 ms Extra echo loss:	> 11 dB	> 12 dB

Requirement 1 does not apply when the FP has a 4-wire through connection to the PSTN/ISDN. Nor do the requirements 1 or 2 apply when the FP is connected to a GSM network, because the corresponding echo control function shall be disabled if implemented. See clauses 8.2.1.1 and 8.3.1.

NOTE: A general solution for the modified Requirements 1 and 2 is to apply an echo canceller for TELR 29 dB and 0 - 60 ms control range.

Annex A (informative): Description of "reference" echo control devices

This annex describes reference echo control devices based upon concepts that are as simple as possible but include a sufficient number of features to give guidance for a wide range of possible implementations. The use of the term "reference" denotes an implementation given for guidance and illustration only. It does not exclude other implementations nor does it imply that the described devices are necessarily the most appropriate realization on any technical, operational or economic grounds. See ITU-T Recommendation G.165 [7].

A.1 Handset echo

A.1.1 Overview

A.1.1.1 Connection to the PSTN/ISDN

FPs with 4-wire connection should provide the artificial echo specified in clause 7.4.1.2 a). It should be disabled if the PP meets the requirements of clause 7.4.1.1 a), $TCLW > 46$ dB, and may be disabled on available call routing information.

The combined handset and hybrid echo from analogue telephones is considerably higher than the DECT 34 dB TCLW echo. Therefore the international planning rules demand provision of echo control devices in the public network, if the one-way network echo delay exceeds 25 ms. See ITU-T Recommendation G.131 [5], clause 4.1.

A.1.1.1.1 Local and national calls

The 34 dB TCLW for a DECT system will give the far-end user a TELR of about 44 dB. This will meet the echo requirements with good margin for connections with one-way delay (excluding DECT) less than 25 ms. See the "acceptable" curve of figure 2 in ITU-T Recommendation G.131 [5]. The requirement is met for DECT systems at both ends of the connection also with a DECT tethered local loop replacement in the public network.

A.1.1.1.2 Long distance connections with echo control devices in the PSTN/ISDN, e.g. calls via satellites

Echo control devices are provided in the public network for connections with more than 25 ms one-way network delay. Older devices are of echo suppressor type ITU-T Recommendation G.164 [6]. Most used are echo cancellers ITU-T Recommendation G.165 [7].

These devices are designed to eliminate echoes from analogue telephones when the one-way delay of the national network is less than 12 ms. The echo path delay capabilities of modern echo cancellers is often 64 ms (or more). These echo cancellers will eliminate echoes with less than 30 ms one-way delay.

However, as long as these devices are active, they will also eliminate the DECT acoustic echo. The 34 dB attenuated echo is low enough not to be detected as break-in speech during single talk condition during speech from the far-end. The DECT echo will therefore be eliminated by an echo suppressor or by the Non-Linear Processor (centre clipper), NLP, of an echo canceller, whichever device is used. Both the suppressor and the NLP have hangover times which will prevent the delayed DECT echo to be heard even at the end of a speech sentence.

The artificial echo, clause 7.4.1.2 option a) simulates the echo from a very good analog 2-wire telephone. When an echo canceller is used in the network, the artificial echo loss path provides an echo, that is guaranteed in-range for the linear echo estimation process. This will ensure that the echo canceller and its NLP are active. The artificial echo is principally not needed to keep echo suppressors nor all types of echo cancellers active, but it does not hurt either.

A.1.1.2 Connection to the GSM network

When a DECT system is connected in tandem with a GSM mobile network (see clause 8.2.1) or a GSM fixed network (see clause 8.3) the FP provides the echo control function specified in clause 7.4.1.2 b). It should be disabled if the PP meets the requirements of clause 7.4.1.1 a), $TCL_w > 46$ dB, and for the case of Discontinuous, DTX, specified in clause 8.2.1.4.

Echo control function specified in clause 7.10 should be disabled.

A.1.2 Implementation of the FP echo control function

The FP echo control function is described in clause 7.4.1.2, item b).

The needed extra echo loss can preferably be implemented by using a Non-Linear Processor (NLP) that, when active, clips all sending signals lower than the suppression threshold. See figure A.1.

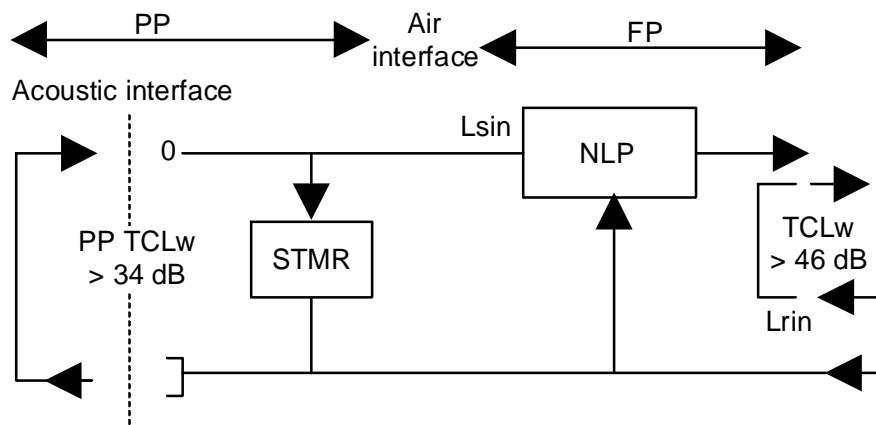

Figure A.1: Implementation of the handset echo control

Such a NLP is described in ITU-T Recommendation G.165 [7], annex C. Two variants are included, both based on an analogue centre clipper having the transfer function illustrated in figure A.2.

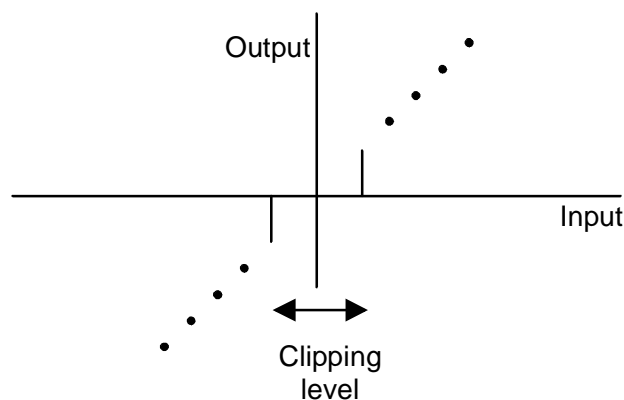

Figure A.2: Transfer function of non-linear processor

In the first case the suppression threshold level is adaptive, adaptation being by reference to L_{rin} . In the second variant the suppression level is fixed.

A.1.2.1 Suppression threshold

The value of the suppression threshold depends on the handset acoustic TCL, below called PTCL:

Fixed: $V_{sup} = (-PTCL) \text{ dBm0}$;

Adaptive: $V_{sup} = (L_{rin} - PTCL + 6) \text{ dBm0}$.

6 dB is the operation margin that prevents the possible ambient noise to pass through the activated NLP. If the noise is high enough to pass through, it will also be high enough to mask the echo.

PTCL is $> 34 \text{ dB}$.

If for example PTCL is set to 30 dB; then

$V_{sup} = -30 \text{ dBm0}$; or

$V_{sup} = L_{rin} - 24 \text{ dB}$.

A.1.2.2 Static characteristics of activation control

In ITU-T Recommendation G.165 [7], annex C, the activation control is defined by reference to L_{rin} . The NLP is active when the level of signal in the sending direction L_{sin} is lower than the activation threshold V_{act} :

Fixed: $V_{act} = (L_{rin} - 6) \text{ dBm0}$;

Adaptive: $V_{act} = (L_{rin} - PTCL + 6) \text{ dBm0}$.

As we are dealing here with acoustic echo in a terminal equipment instead of electric echo in the network, a simplification seems reasonable and V_{act} can be fixed:

$V_{act} = -31 \text{ dBm0}$.

A.1.2.3 Dynamic characteristics of activation control

Table A.1: Non-linear processor hangover times

Switch from	V_{sup} variant	Recommended values
active to inactive	fixed	15 - 64 ms
	adaptive	2 ms (echo path delay)
inactive to active	fixed	20 - 120 ms
	adaptive	30 - 50 ms

A.2 Network echo

The requirement on network echo control (see clause 7.10) can be met with the following implementation, depending on the type of line interface:

- 1) for 4-wire interface, a soft suppressor (see figure A.3);
- 2) for 2-wire interface, a soft suppressor and an echo canceller (see figure A.4).

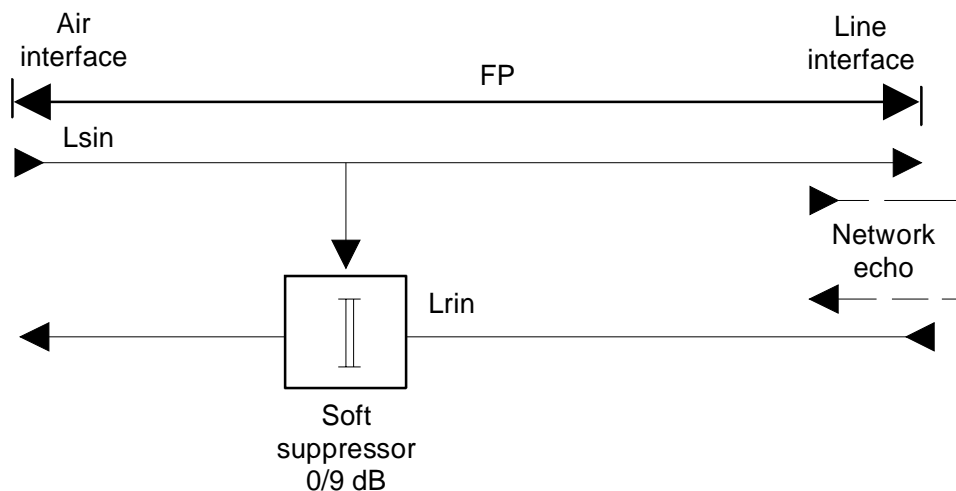

Figure A.3: Implementation of the network echo control 4-wire line interface

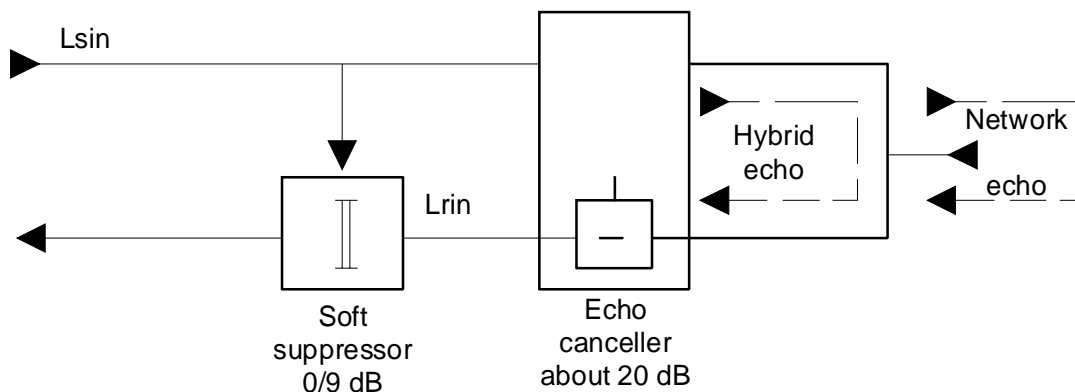

Figure A.4: Implementation of the network echo control 2-wire line interface

A.2.1 Soft suppressor implementation of requirement 2

Soft suppressor requirement 2 is described in clause 7.10.

A 9 dB soft echo suppressor meets the whole requirement for 4-wire connection and a part of the requirement for the 2-wire connection. The principle of operation is similar to the one described in ITU-T Recommendation G.164 [6]. Therefore the same operational parameters can be used.

The 9 - 12 dB loss for requirement 2 is intended to cover different foreseen connection cases. It is also a compromise between reduction of echoes from badly matched far-end national hybrids, and low noise contrast requirements.

In most applications the majority of calls will not need any extra echo suppression, and therefore optimization should be made to minimize the noise contrast. Thus the lower 9 dB value is recommended.

The 9 - 12 dB loss is required when no routing information is available. When suitable routing information is available, the operator is allowed to disconnect or reduce the loss below 9 dB to optimize it for specific connections or applications.

This parameter of requirement 2 only effects the DECT user and not the general network planning rules.

A.2.1.1 Static characteristics

The echo suppressor is active if the speech level in the sending direction L_{sin} is greater than the suppression threshold:

$$V_{sup} = -31 \text{ dBm0.}$$

The suppressor becomes inactive if the speech level falls under the release threshold:

$$V_{rel} = V_{sup} (+0 \text{ dB, } -3 \text{ dB}).$$

A.2.1.2 Dynamic characteristics

The switching characteristics are taken from ITU-T Recommendation P.340 [12], that relates to terminal equipment and seems more appropriate than ITU-T Recommendation G.164 [6], that relates to network echo suppressor ($T_r \leq 2 \text{ ms}$ and $T_h = 24 \text{ to } 36 \text{ ms}$).

- 1) Build-up time: $T_r < 15 \text{ ms}$, preferably $< 10 \text{ ms}$.
- 2) Hang-over time: $T_h > 100 \text{ ms}$, preferably between 150 and 250 ms.

The soft suppressor may pass a 6 dB state at the switch on and switch off of the 9 to 12 dB attenuation. The 6 dB state should be of less than 15 ms duration.

A.2.2 Additional echo control for a 2-wire interface of requirement 1

Additional echo control for a 2-wire interface of requirement 1 is described in clause 7.10.

For the 2-wire case a Talker's Echo Loudness Rating (TELR) of 24 dB is required for the delayed sidetone from the FP's 2-wire interface. This can be performed in some cases by hybrid matching, or more generally by means of an echo canceller.

In order to meet the requirement of TELR = 24 dB for the three terminating impedances according to clause 7.10, around 20 dB extra loss is estimated to be required for the worst cases of mismatch. This implies that for normal cases, TELR > 30 dB is expected for the delayed sidetone.

TELR = 24 dB equates to $L_{Le} = 14 \text{ dB}$ at the PCM reference point of the FP.

NOTE: The solution using an adaptive soft suppressor with up to 20 dB attenuation is not recommended.

Such an echo canceller should be rather simple to implement since the control range is limited to 4 ms. But it is peculiar in the sense that the near-end echo may be equal or even higher than the far-end signal.

The echo canceller is operating on the uniform PCM speech signals. It makes a linear estimate A_{canc} of the echo path A_{echo} (see figure A.5), and subtract this estimate at the subtractor. The residual echo level after the subtractor is L_{res} . L_{fes} is the level of the far-end speech.

$$L_{res} = L_{sin} - A_{echo} - A_{canc} \quad (\text{in power});$$

$$L_{rout} = L_{res} + L_{fes}.$$

Since the worst case A_{echo} is -1 dB, the required A_{canc} is about 15 - A dB. Therefore no NLP is needed to further reduce L_{rout} . A is the attenuation of the soft suppressor for requirement 2. If the soft suppressor can be disabled (e.g. for local PABX calls), A is set to zero during type approval testing EN 300 176 [3].

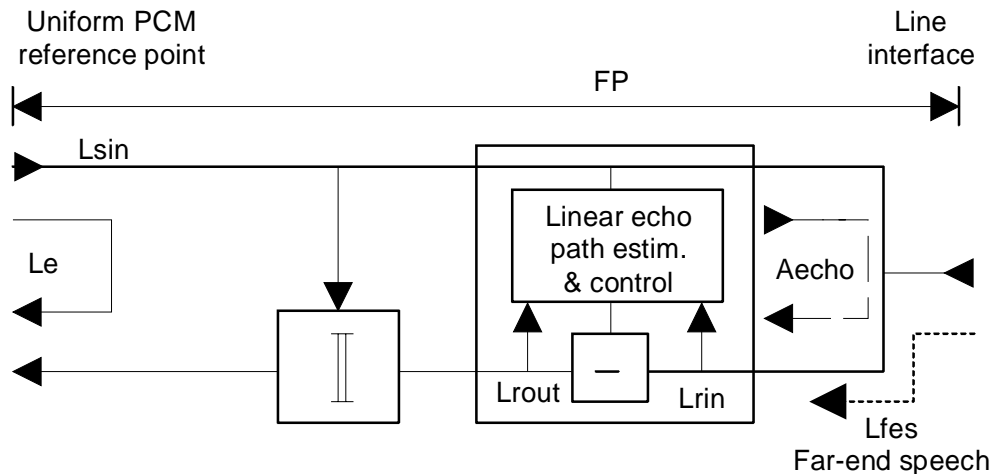

Figure A.5: Echo canceller implementation

Speech detection for e.g. double talk, cannot be made before the subtractor (L_{rin}), as in ITU-T Recommendation G.165 [7], because the level of the hybrid echo can be larger than the level of the far-end signal.

Detection of the far-end speech has to be made after the subtractor (L_{rout}), and detection is only possible when the near end echo is cancelled to a certain degree.

Thus at the start (adaptation coefficients = 0), the FES detector is switched off. It is switched on once L_{rout} is below a certain threshold. This will only happen when L_{fes} is very low and the filter adaptation is satisfying (L_{res} low).

At detected double talk, the adaptation cannot be completely switched off, but the adaptation speed should be reduced by a factor of e.g. 4. This allows adaptation during conversation if the echo path suddenly is changed.

A.2.3 Echo canceller used for both requirements 1 and 2

An alternative to implementing a soft suppressor, is to use an echo canceller as described in clause A.2.2 with the control range prolonged to 70 ms. This solution may be more expensive, but will give better performance for PP reception on a noisy connection.

Annex B (informative): Local loop application

This annex relates to public local loop applications.

A PP is a physical grouping that contains all elements between the user and the DECT air interface. A PP is a generic term that may describe one or several physical pieces.

A PP is logically divided into one PT plus zero or more Terminal Adaptors (TA) plus one or more End Systems (ESs).

The ES can thus be implemented in a handset, or be e.g. a standard ISDN terminal, a standard 2-wire telephone or even a cordless telephone system, tethered to a TA via a standard subscriber's telephone socket.

Below, guidance is given for the case when the ES is connected via a standard 2-wire socket, e.g. in a public local loop evolutionary application.

B.1 DECT tethered local loop replacement with 2-wire PP end system

Below we consider the case when a public operator uses DECT for a local loop replacement.

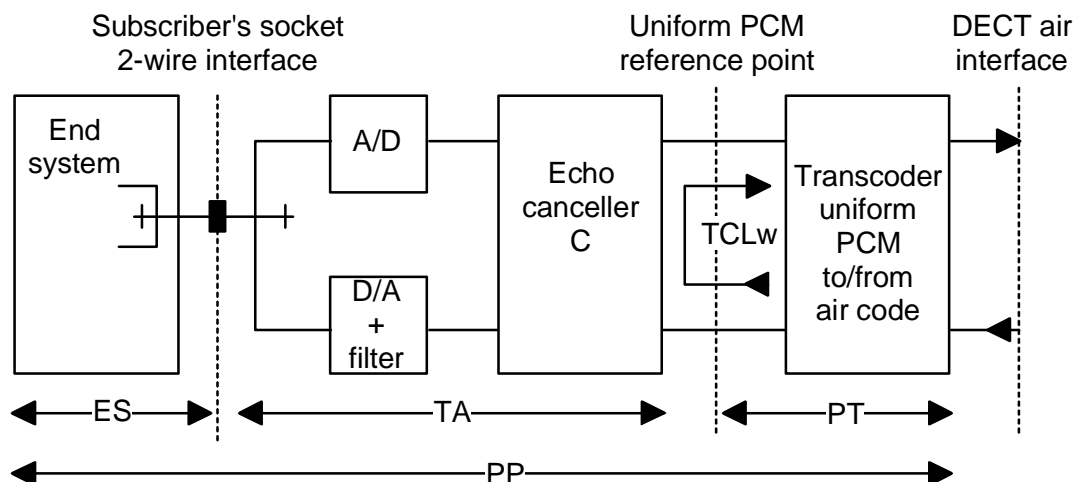

Figure B.1: PP in tethered local loop application

B.1.1 TCLw requirements

If the public operator plans the control range of his echo cancellers at the international gateways to include the hybrids at the subscriber's socket interface and a standard telephone end system, then no extra echo canceller C is needed.

If the hybrids in figure B.1 are outside the control range of the echo cancellers at the international gateways, then the hybrid's echo return loss LL_{eh} has to be > 34 dB. If this is not met, an echo canceller C, with about 20 dB extra echo attenuation and with a 4 ms control range, of the same type as described in clause A.2.2 (without the soft suppressor) is needed in the PP TA.

The echo control device may in principle for some installation cases, alternatively be implemented at the FP with a control range of 20 to 28 ms (or more if Wireless Base Stations (WBSs) are implemented). At the FP some trunking gain can be provided on needed number of simultaneous echo control functions.

If the ES has higher loop delay than a standard telephone (2 ms), e.g. a residential DECT system, this system has to meet the normal TCLw requirements of clause 7.4.1.1. See clauses A.1.1.1.1 and A.1.1.1.2.

B.1.2 Network echo

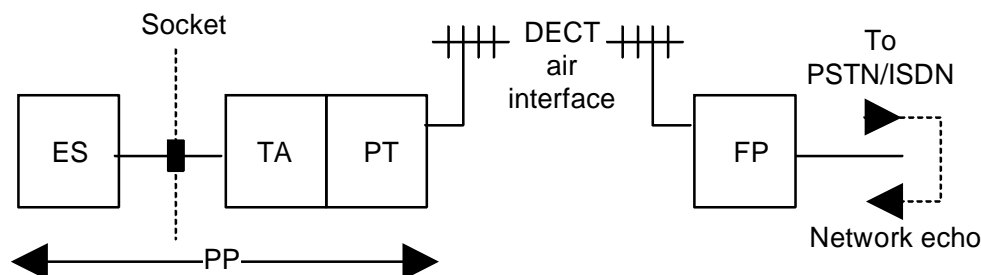

Figure B.2: DECT local loop replacement

The FP of figure B.2 has to meet the normal echo control requirements 1 and 2 of clause 7.10.

If the ES is a (residential) DECT system, each FP will meet the requirement of clause 7.11 and take care of its own network echo.

It is however recommended that requirement 2 is realized with an echo canceller, or a soft suppressor with reduced echo loss if the operator has a modern network, see clause A.2.1.

This recommendation is to minimize the noise contrast for the case when the ES is a DECT residential system, also implementing requirement 2.

It is allowed to disconnect or reduce requirement 2, when suitable routing information is available. This may be the case for FPs under control of one operator in a local loop application. For instance, if an operator has a modern network where the far-end hybrids have $LL_e > 20$ dB, a reduction to 6 dB could be suitable if the loss in the FP in figure B.2 is implemented as a soft suppressor and not as an echo canceller.

B.2 Quantization distortion considerations

The number of Quantization Distortion Units (QDUs) accumulated by a connection could potentially exceed the recommended limits for transmission planning, see ETR 041 [20]. A 32 kbit/s ADPCM codec introduces about 3 QDUs.

If analogue 2-wire connections are provided in the customers' premises, the operator has the options to choose a 32 kbit/s ADPCM bearer or a 64 kbit/s PCM bearer in the DECT local loop link. Choosing the 32 kbit/s ADPCM bearer is more frequency efficient, choosing a 64 kbit/s PCM bearer avoids the potential risk of adding QDUs from two ADPCM codecs when the customer uses a DECT system in his premises.

If only digital 4-wire connections are provided in the customers premises the DECT FP of the customer will incorporate synchronous coding adjustment. Hence the second ADPCM codec on the DECT local loop link will not introduce any additional QDUs. Synchronous coding adjustment should also be implemented in the local loop link if further ADPCM stages are used in the national network.

Annex C (informative): GSM Discontinuous Transmission (DTX), and Voice Activity Detection (VAD)

Discontinuous Transmission (DTX) and Voice Activity Detection (VAD) are mandatory features in a GSM mobile, but not in a GSM base station. A GSM mobile has to be able to operate in both modes.

Without DTX and VAD in the up-link, TCL 34 dB and NLP in the FP meet the requirements.

If VAD and DTX is implemented the DECT TCL echo path is broken except for double talk. At double talk TCL 34 dB should be enough, since the echo level will be 34 dB below the (annoying) double talk and is masked by the double talk. Furthermore double talk occupies only a small fraction of the speech time.

The 34 dB attenuated echo is not interpreted as a speech break-in signal. When DTX is implemented, the normal background speech or music in a public environment should not eliminate the DTX function. For example, in ITU-T Recommendations G.164 [6] and G.165 [7] double talk state occurs only if the "sending speech" level is higher than the "receiving speech" level -6 dB.

The VAD is extracting noise parameters in speech pauses in the signal from the microphone (sending speech). The VAD might need to detect speech pauses at 40 - 45 dBmO levels, in order to deliver clean noise parameters to the GSM base station, for noise insertion in DTX pauses. But these low levels need not be related to levels required to prevent background speech or an acoustic echo to eliminate the DTX function. The VAD is specially designed for traffic and motor noise in a car, and not optimized for an environment with background speech and music.

Therefore it is stated in clause 8.2.1.2 "that the GSM mobile transmitter shall not be activated (double-talk state) by a sending speech signal with a level of less than 30 dB below receiving speech level". If ITU-T Recommendation G.164 [6] and ITU-T Recommendation G.165 [7] are used as guidance for an upper level, a threshold may be implemented somewhere in the range - 6 dB to - 30 dB below the level of the speech received from the far-end.

Annex D (informative): Speech levels in relation to ambient room noise and examples of adaptive volume control settings

When room noise is present a higher received speech signal level (lower RLR_H) is required to give the best possible receiving speech quality and intelligibility. The increase in the receiving level is a function of increasing room noise level.

When room noise is present people raise their voice level (talk louder) and the sending speech level will be higher than the optimum level. By decreasing the sending sensitivity (higher SLR_H) the sending level to the line will be around optimum and at the same time the absolute level of the transmitted noise will decrease.

The increase in receiving sensitivity and the decrease in sending sensitivity is approximately linearly related to increasing room noise level. For every dB increase in room noise level there is a corresponding increase in receiver sensitivity and decrease in sending sensitivity of about 0,5 dB.

Table D.1 presents - for guidance and illustration only - three examples of volume control characteristics.

Table D.1: Examples of FP adaptive volume control

Ambient noise		Volume variation receiving (sending)	
Single threshold	between 50 and 55 dBA	8 dB gain	(attenuation)
Double threshold	50 dBA 60 dBA	5 dB gain 10 dB gain	(attenuation) (attenuation)
Continuous variation	from 30 to 50 dBA from 50 to 70 dBA	3 dB increase 8 dB increase	(decrease) (decrease)

Annex E (informative): Bibliography

ETSI TR 101 310: "Digital Enhanced Cordless Telecommunications (DECT); Traffic Capacity and Spectrum Requirements for Multi-System and Multi-Service DECT Applications Co-existing in a Common Frequency Band."

ETSI EN 300 175-2: "Digital Enhanced Cordless Telecommunications (DECT); Common Interface (CI); Part 2: Physical Layer (PHL)".

ETSI EN 300 175-3: "Digital Enhanced Cordless Telecommunications (DECT); Common Interface (CI); Part 3: Medium Access Control (MAC) layer".

ETSI EN 300 175-4: "Digital Enhanced Cordless Telecommunications (DECT); Common Interface (CI); Part 4: Data Link Control (DLC) layer".

ETSI EN 300 175-6: "Digital Enhanced Cordless Telecommunications (DECT); Common Interface (CI); Part 6: Identities and addressing".

ETSI EN 300 175-7: "Digital Enhanced Cordless Telecommunications (DECT); Common Interface (CI); Part 7: Security features".

ETSI EN 300 444: "Digital Enhanced Cordless Telecommunications (DECT); Generic Access Profile (GAP)".

History

Document history		
Edition 1	October 1992	Publication as ETS 300 175-8
Edition 2	September 1996	Publication as ETS 300 175-8
V1.4.2	June 1999	Publication
V1.5.0	October 2000	One-step Approval Procedure OAP 20010216: 2000-10-18 to 2001-02-16
V1.5.1	February 2001	Publication