

ETSI EN 300 175-3 V2.5.0 (2013-04)



**Digital Enhanced Cordless Telecommunications (DECT);
Common Interface (CI);
Part 3: Medium Access Control (MAC) layer**

Reference

REN/DECT-000268-3

Keywords

DECT, IMT-2000, MAC, mobility, radio, TDD,
TDMA

ETSI

650 Route des Lucioles
F-06921 Sophia Antipolis Cedex - FRANCE

Tel.: +33 4 92 94 42 00 Fax: +33 4 93 65 47 16

Siret N° 348 623 562 00017 - NAF 742 C
Association à but non lucratif enregistrée à la
Sous-Préfecture de Grasse (06) N° 7803/88

Important notice

Individual copies of the present document can be downloaded from:

<http://www.etsi.org>

The present document may be made available in more than one electronic version or in print. In any case of existing or perceived difference in contents between such versions, the reference version is the Portable Document Format (PDF). In case of dispute, the reference shall be the printing on ETSI printers of the PDF version kept on a specific network drive within ETSI Secretariat.

Users of the present document should be aware that the document may be subject to revision or change of status. Information on the current status of this and other ETSI documents is available at

<http://portal.etsi.org/tb/status/status.asp>

If you find errors in the present document, please send your comment to one of the following services:

http://portal.etsi.org/chaicor/ETSI_support.asp

Copyright Notification

No part may be reproduced except as authorized by written permission.
The copyright and the foregoing restriction extend to reproduction in all media.

© European Telecommunications Standards Institute 2013.
All rights reserved.

DECT™, **PLUGTESTS™**, **UMTS™** and the ETSI logo are Trade Marks of ETSI registered for the benefit of its Members.
3GPP™ and **LTE™** are Trade Marks of ETSI registered for the benefit of its Members and
of the 3GPP Organizational Partners.
GSM® and the GSM logo are Trade Marks registered and owned by the GSM Association.

Contents

Intellectual Property Rights	14
Foreword.....	14
1 Scope	15
2 References	15
2.1 Normative references	15
2.2 Informative references.....	16
3 Definitions, symbols and abbreviations	17
3.1 Definitions.....	17
3.2 Symbols and abbreviations.....	17
4 Description of the MAC layer	20
4.1 MAC layer reference model	20
4.1.1 General.....	21
4.1.2 Cluster Control Function (CCF)	21
4.1.3 Cell Site Functions (CSF).....	21
4.1.4 Relationship to physical layer elements.....	21
4.2 Frame and multiframe structures.....	22
4.2.1 General.....	22
4.2.2 Frame structure	22
4.2.3 Multiframe structure	24
4.3 State definitions.....	24
4.3.1 PP states	24
4.3.2 RFP states	25
5 Overview of MAC layer services.....	26
5.1 General	26
5.1.1 Broadcast Message Control (BMC).....	26
5.1.2 Connectionless Message Control (CMC)	26
5.1.3 Multi-Bearer Control	26
5.2 Service descriptions.....	26
5.2.1 Common functions.....	26
5.2.2 BMC service	27
5.2.3 CMC service	27
5.2.4 MBC services.....	27
5.3 Logical channels.....	28
5.3.1 MBC connection endpoints (MC-SAP logical channels)	28
5.3.1.1 The higher layer C-plane channels, C	28
5.3.1.2 The higher layer U-Plane channels, I	29
5.3.1.3 The higher layer U-Plane control channels, G_F and G_{FA}	29
5.3.1.4 The higher layer U-Plane channel in E+U type slots, I_{PF}	29
5.3.2 CMC endpoints (MB-SAP logical channels).....	30
5.3.2.1 The connectionless C-Plane channels, CL	30
5.3.2.2 The connectionless U-Plane channels, SI_N and SI_P	30
5.3.2.3 The connectionless U-Plane channel in E+U type slots, SI_{PF}	30
5.3.3 BMC endpoint (MA-SAP logical channel).....	30
5.3.3.1 The slow broadcast channel, B_S	30
5.3.3.2 The ULE broadcast channel, B_U	31
5.3.4 Internal MAC control channels.....	31
5.3.4.1 The system information channel, Q	31
5.3.4.2 Identities channel, N.....	31
5.3.4.3 The MAC control channel, M	31
5.3.4.4 MAC paging channel, P	32
5.3.4.5 The Compound System Information Channel, Q_C	32
5.3.4.6 The Split Identities Channel, N_S	32
5.3.4.7 The ULE MAC Control Channel, M_U	32

5.3.4.8	The ULE Paging Channel, P _U	32
5.4	SAP definitions	32
5.4.1	MA SAP	33
5.4.2	MB SAP	33
5.4.3	MC SAP	33
5.4.4	ME SAP	34
5.4.5	Order of transmission.....	34
5.5	Bearer.....	34
5.5.1	Bearer types	34
5.5.2	Bearer operation.....	35
5.6	Connection oriented services.....	35
5.6.1	Connection types	35
5.6.1.1	Basic connections.....	36
5.6.1.2	Advanced connections	36
5.6.1.2.1	Rules for ECN selection in advanced connections	36
5.6.1.2.2	Expedited operations in advanced connections	37
5.6.1.3	Connection identifiers	37
5.6.1.4	Complementary connections	37
5.6.2	Symmetric and asymmetric connections.....	37
5.6.2.1	Symmetric connections	38
5.6.2.2	Asymmetric connections	43
5.7	Broadcast and connectionless services	54
5.7.1	The broadcast services	54
5.7.1.1	The continuous broadcast service	54
5.7.1.2	The non-continuous broadcast service	55
5.7.2	The connectionless services	55
5.7.2.1	Connectionless downlink services	55
5.7.2.2	Connectionless uplink services	55
5.8	ULE Broadcast services	56
5.8.1	The continuous ULE broadcast service.....	56
6	Multiplexing	56
6.1	CCF multiplexing functions	56
6.2	CSF multiplexing functions.....	57
6.2.1	Bit Mappings (MAP).....	62
6.2.1.1	D-field mapping (D-MAP).....	62
6.2.1.1.1	D-field mapping for the double slot structure (physical packet P80)	63
6.2.1.1.2	D-field mapping for the full slot structure (physical packet P32).....	64
6.2.1.1.3	D-field mapping for the short slot structure (physical packet P00)	64
6.2.1.1.4	D-field mapping for the variable slot structure (physical packet P00j)	65
6.2.1.2	A-field Mapping (A-MAP)	66
6.2.1.3	B-field Mapping (B-MAP).....	67
6.2.1.3.1	Unprotected format.....	67
6.2.1.3.2	Encoded protected format.....	69
6.2.1.3.3	Multisubfield protected format	69
6.2.1.3.4	Singlesubfield protected format switches	72
6.2.1.3.5	Constant-size subfield protected format	73
6.2.2	Time multiplexers	76
6.2.2.1	Tail MULTipleXer (T-MUX)	76
6.2.2.1.1	T-MUX algorithm for RFP transmissions	76
6.2.2.1.2	T-MUX algorithm for PT transmissions.....	78
6.2.2.2	B-field control multiplexer (E/U-MUX)	78
6.2.2.3	B-field mode multiplexer E-type and E+U-type modes	80
6.2.2.3.1	E-type and E+U-type modes for slots with more than one subfield	80
6.2.2.3.2	Half slot (j=80) modes for 2-level modulation	94
6.2.2.4	Priority scheme in E or E+U mode	95
6.2.3	MAC Encryption	96
6.2.4	Scrambling	96
6.2.5	Error control.....	98
6.2.5.1	R-CRC overview	98
6.2.5.2	R-CRC generation and checking	99
6.2.5.3	X-CRC overview.....	99

6.2.5.4	X-CRC generation and checking.....	99
6.2.5.5	B-CRC generation and checking.....	102
6.2.6	Broadcast controller.....	102
7	Medium access layer messages	102
7.1	Header field.....	103
7.1.1	Overview/formatting.....	103
7.1.2	Tail identification, TA, bits a_0 to a_2	103
7.1.3	The "Q1/BCK" bit, bit a_3	103
7.1.4	B-field identification, BA, bits a_4 to a_6	104
7.1.5	The "Q2" bit, bit a_7	105
7.2	Messages in the tail field.....	105
7.2.1	Overview	105
7.2.2	Identities information (N_T).....	106
7.2.3	System information and multiframe marker (Q_T).....	106
7.2.3.1	General.....	106
7.2.3.2	Static system information.....	107
7.2.3.2.1	General, $Q_H = 0, 1$ (hex).....	107
7.2.3.2.2	Q_H and Normal-Reverse (NR).....	107
7.2.3.2.3	Slot Number (SN).....	107
7.2.3.2.4	Start Position (SP).....	108
7.2.3.2.5	ESCAPE bit (ESC).....	108
7.2.3.2.6	Number of transceivers.....	108
7.2.3.2.7	Extended RF carrier information available (M_c).....	109
7.2.3.2.8	RF carriers available (RF-cars).....	109
7.2.3.2.9	Spare bits (SPR).....	109
7.2.3.2.10	Carrier number.....	109
7.2.3.2.11	Extended static system information available (Ext-System-Info) and spare bit.....	110
7.2.3.2.12	Primary receiver Scan Carrier Number (PSCN).....	110
7.2.3.3	Extended RF carrier information part 1	110
7.2.3.3.1	General, $Q_H = 2$ (hex).....	110
7.2.3.3.2	Further RF carrier extensions	111
7.2.3.3.3	Number of RF carriers.....	111
7.2.3.4	Fixed part capabilities	111
7.2.3.4.1	General, $Q_H = 3$ (hex).....	111
7.2.3.4.2	Standard capabilities.....	111
7.2.3.5	Extended fixed part capabilities	113
7.2.3.5.1	General, $Q_H = 4$ (hex).....	113
7.2.3.5.2	Extended Physical and MAC layer capabilities.....	113
7.2.3.5.3	Extended higher layer capabilities.....	114
7.2.3.6	Secondary access rights identities	114
7.2.3.6.1	General, $Q_H = 5$ (hex).....	114
7.2.3.6.2	SARI message	114
7.2.3.7	Multiframe number	115
7.2.3.7.1	General, $Q_H = 6$ (hex).....	115
7.2.3.7.2	Multiframe number.....	115
7.2.3.8	Escape	115
7.2.3.8.1	General, $Q_H = 7$ (hex).....	115
7.2.3.8.2	Escape information.....	115
7.2.3.9	Extended RF carrier information part 2	115
7.2.3.9.1	General, $Q_H = 9$ (hex).....	115
7.2.3.10	Transmit information	116
7.2.3.10.1	General, $Q_H = B$ (hex).....	116
7.2.3.11	Extended fixed part capabilities (part 2)	117
7.2.3.11.1	General, $Q_H = C$ (hex).....	117
7.2.3.11.2	Extended Physical and MAC layer capabilities (part 2).....	117
7.2.3.11.3	Extended higher layer capabilities (part 2).....	118
7.2.3.12	Extended static system information	118
7.2.3.12.1	General, $Q_H = D$ (hex).....	118
7.2.3.12.2	Spare bits (Spare).....	118
7.2.3.12.3	RFP slot scheme info.....	118
7.2.4	Paging Tail (P_T).....	119

7.2.4.1	General format	119
7.2.4.1.1	P _T format for full and long page messages	119
7.2.4.1.2	P _T format for short page messages	119
7.2.4.1.3	P _T format for zero length page messages.....	119
7.2.4.1.4	P _T format for MAC_Resume_and_Control_page message	119
7.2.4.2	P _T header format.....	120
7.2.4.2.1	General format.....	120
7.2.4.2.2	Bit a ₈ is the extend flag.....	120
7.2.4.2.3	B _S SDU length indication	120
7.2.4.3	MAC layer information for PT.....	121
7.2.4.3.1	Information type	121
7.2.4.3.2	Fill bits / Blind long slot (j=640 / j=672) information	121
7.2.4.3.3	Blind full slot information	122
7.2.4.3.4	Bearer description.....	122
7.2.4.3.5	Escape.....	123
7.2.4.3.6	Dummy or connectionless downlink bearer marker	123
7.2.4.3.7	Bearer handover/replacement and no-emission mode information	123
7.2.4.3.8	RFP status and modulation types.....	124
7.2.4.3.9	Active carriers	125
7.2.4.3.10	RFP power level	125
7.2.4.3.11	Blind double slot/RFP-FP interface resource information.....	126
7.2.4.3.12	Extended modulation types	126
7.2.5	MAC control (M _T)	127
7.2.5.1	General format and contents	127
7.2.5.2	Basic connection control	127
7.2.5.2.1	General	127
7.2.5.2.2	Format for most messages	128
7.2.5.2.3	WAIT	128
7.2.5.2.4	ATTRIBUTES_T_{Req;Cfm}	128
7.2.5.3	Advanced connection control.....	129
7.2.5.3.1	General	129
7.2.5.3.2	ACCESS_REQUEST	129
7.2.5.3.3	BEARER_HANDOVER_REQUEST	129
7.2.5.3.4	CONNECTION_HANDOVER_REQUEST	129
7.2.5.3.5	UNCONFIRMED_ACCESS_REQUEST	130
7.2.5.3.6	BEARER_CONFIRM	130
7.2.5.3.7	WAIT	130
7.2.5.3.8	ATTRIBUTES_T_{Req;Cfm}	130
7.2.5.3.9	BANDWIDTH_T_{Req;Cfm}	133
7.2.5.3.10	Channel_list	133
7.2.5.3.11	Unconfirmed_dummy.....	134
7.2.5.3.12	Unconfirmed_handover	134
7.2.5.3.13	RELEASE	134
7.2.5.4	MAC layer test messages	135
7.2.5.4.1	Basic format	135
7.2.5.4.2	FORCE_TRANSMIT	136
7.2.5.4.3	LOOPBACK_DATA	136
7.2.5.4.4	DEFEAT_ANTENNA_DIVERSITY.....	137
7.2.5.4.5	ESCAPE	138
7.2.5.4.6	NETWORK_TEST.....	138
7.2.5.4.7	CLEAR_TEST_MODES.....	138
7.2.5.4.8	CHANGE_MODULATION_SCHEME	138
7.2.5.5	Quality control	139
7.2.5.5.1	Prolonged preamble diversity	140
7.2.5.6	Broadcast and connectionless services.....	141
7.2.5.7	Encryption control.....	141
7.2.5.8	B-field setup, first PT transmission.....	142
7.2.5.9	Escape	143
7.2.5.10	TARI message.....	143
7.2.5.11	REP connection control.....	143
7.2.5.11.1	General	143
7.2.5.11.2	Format for most messages	143

7.2.5.11.3	REP CHANNEL MAP REQUEST	144
7.2.5.11.4	REP CHANNEL MAP CONFIRM	144
7.2.5.12	Advanced connection control part 2.....	144
7.2.5.12.1	General	144
7.2.5.12.1	Short description of the advanced connection control part 2 messages.....	144
7.2.5.12.3	Format for most advanced connection control part 2 messages	145
7.2.5.12.4	Format for "ready for release with G _{FA} " and "expedited release with G _{FA} " messages.....	145
7.2.5.12.5	Reason codes in "ready for release with G _{FA} " and "expedited release with G _{FA} " messages	146
7.2.5.12.6	Format for "Null or GFACHannel transmission" message	148
7.3	Messages in the B-field	148
7.3.1	Overview	148
7.3.2	Advanced connection control	150
7.3.2.1	General format	150
7.3.2.2	BEARER_REQUEST	150
7.3.2.3	BEARER_CONFIRM.....	151
7.3.2.4	WAIT	151
7.3.2.5	ATTRIBUTES_B_{Req;Cfm}	151
7.3.2.6	BANDWIDTH_B_{Req;Cfm}	152
7.3.2.7	CHANNEL_LIST	153
7.3.2.8	UNCONFIRMED_DUMMY	153
7.3.2.9	UNCONFIRMED_HANDOVER	153
7.3.2.10	RELEASE	153
7.3.3	Null or I _{PF} segmentation info	155
7.3.3.1	Spare or I _{PF} segmentation info	156
7.3.3.2	Extended NCF bits	156
7.3.4	Quality control	157
7.3.4.1	General format	157
7.3.4.2	Bearer and connection control.....	157
7.3.4.3	RESET	159
7.3.4.4	Bearer quality in an asymmetric connection	159
7.3.5	Extended system information	160
7.3.5.1	General format	160
7.3.5.2	TARI messages	160
7.3.5.3	"no-emission" mode sync information or ULE Dummy Bearer subfield 2.....	160
7.3.5.3.1	"no-emission" mode sync information for dummy bearer	160
7.3.5.3.2	ULE Dummy Bearer subfield 2	161
7.3.5.4	ULE Dummy Bearer subfield 3	161
7.3.5.5	ULE Dummy Bearer subfield 0	161
7.3.5.6	ULE Dummy Bearer subfield 1	162
7.3.6	G _F channel data packet.....	162
7.3.7	Escape.....	163
8	Medium access layer primitives	163
8.1	Connection oriented service primitives	163
8.1.1	Connection setup: MAC_CON {req;ind;cfm}	163
8.1.2	Connection modification: MAC_MOD {req;ind;cfm}	165
8.1.3	CO data transmit ready: MAC_CO_DTR {ind}	166
8.1.4	CO data transfer: MAC_CO_DATA {req;ind}	166
8.1.5	Restart DLC: MAC_RES_DLC {ind}	166
8.1.6	Connection release: MAC_DIS {req;ind}	167
8.1.7	MAC bandwidth: MAC_BW {ind;res}	167
8.1.8	Encryption.....	167
8.1.8.1	Load encryption key: MAC_ENC_KEY {req}.....	167
8.1.8.2	Enable/disable encryption: MAC_ENC_EKS {req;ind;cfm}	168
8.1.9	C-plane switching procedure	168
8.1.9.1	C-plane switching procedure: MAC_C _S C _F {req, cfm, ind, res}.....	168
8.1.9.2	C-plane switching procedure: MAC_C _S C _F _END {ind}	168
8.2	Connectionless and broadcast service primitives	169
8.2.1	Paging: MAC_PAGE {req;ind}.....	169
8.2.2	Downlink connectionless: MAC_DOWN_CON {req;ind}	169
8.2.3	Uplink connectionless: MAC_UP_CON {req;ind;cfm}	170

8.2.4	"no-emission" mode.....	170
8.3	Management primitives.....	170
8.3.1	Connection control.....	170
8.3.1.1	Connection setup: MAC_ME_CON {ind}.....	170
8.3.1.2	Connection setup allowed: MAC_ME_CON_ALL {req}.....	170
8.3.1.3	Bearer release: MAC_ME_REL {req}.....	170
8.3.1.4	MBC release report: MAC_ME_REL_REP {ind}.....	171
8.3.2	System information and identities.....	171
8.3.2.1	FP information preloading: MAC_ME_RFP_PRELOAD {req}.....	171
8.3.2.2	PT information preloading: MAC_ME_PT_PRELOAD {req}.....	171
8.3.2.3	System information output: MAC_ME_INFO {ind;res}.....	171
8.3.2.4	Extended system info: MAC_ME_EXT.{req;ind;res;cfm}.....	171
8.3.3	Channel map: MAC_ME_CHANMAP {ind;res}.....	171
8.3.4	Status reports: MAC_ME_STATUS {req;ind;res;cfm}.....	172
8.3.5	Error reports: MAC_ME_ERROR {ind;res}.....	172
8.4	Flow control.....	172
8.4.1	MA SAP flow control.....	172
8.4.2	MB SAP flow control.....	172
8.4.3	MC SAP flow control.....	172
9	Broadcast and connectionless procedures.....	175
9.1	Downlink broadcast and connectionless procedures.....	175
9.1.1	Downlink broadcast procedure.....	175
9.1.1.1	Broadcast information.....	175
9.1.1.2	Channel selection for downlink broadcast services.....	175
9.1.1.3	Downlink broadcast procedure description.....	177
9.1.2	Downlink connectionless procedure.....	177
9.1.2.1	Channel selection at the RFP.....	177
9.1.2.2	Downlink connectionless procedure description.....	177
9.1.3	Paging broadcast procedure.....	177
9.1.3.1	RFP paging broadcasts.....	178
9.1.3.2	PP paging procedures.....	180
9.1.3.2.1	PP paging detection.....	180
9.1.3.2.2	PP paging processing.....	180
9.2	Uplink connectionless procedures.....	180
9.2.1	General.....	180
9.2.2	Bearer selection for the connectionless uplink.....	181
9.2.3	Procedure for the connectionless uplink.....	181
9.2.3.1	Predicates.....	181
9.2.3.2	PT D-field construction.....	181
9.2.3.3	PT transmission sequence.....	182
9.2.3.4	FT procedure.....	182
9.3	Non-continuous broadcast procedure.....	183
9.3.1	Request for specific Q channel information.....	183
9.3.1.1	A-field procedure.....	183
9.3.1.2	B-field procedure.....	183
9.3.2	Request for a new dummy bearer.....	184
9.4	"No-emission" mode procedures.....	184
9.4.1	Initiation of the "no-emission" mode.....	184
9.4.1.1	Successful activation (countdown to zero).....	184
9.4.1.2	Multiframe countdown stopped by FT.....	185
9.4.1.3	Multiframe countdown stopped by PT.....	185
9.4.1.4	PT does not receive multiframe countdown "zero".....	186
9.4.2	Behaviour during power-down-mode.....	186
9.4.3	Waking up, FT initiated.....	186
9.4.4	Waking up, PT initiated.....	190
9.5	Ultra Low Energy (ULE) Mode Procedures.....	191
9.5.1	Initiation of the ULE Mode.....	191
9.5.1.1	ULE Dummy Bearer Subfield 0.....	192
9.5.1.2	ULE Dummy Bearer Subfield 1.....	192
9.5.1.3	ULE Dummy Bearer Subfield 2.....	193
9.5.1.3.1	M _U Channel Info 1 coding.....	194

9.5.1.3.2	M _U Channel Info 2 coding	194
9.5.1.4	ULE Dummy Bearer Subfield 3	194
9.5.1.5	Broadcast/Paging Channels	195
10	Connection oriented service procedures	196
10.1	Overview	196
10.2	C/O connection setup	196
10.2.1	General	196
10.2.2	Initiation of a basic and a normal connection setup	197
10.2.3	Initiation of a fast connection setup	197
10.2.4	Connection setup procedure description	197
10.2.4.1	Creation of MBCs	197
10.2.4.2	Establishment of a single bearer duplex connection of a known service type	199
10.2.4.3	Establishment of multi-bearer connections and connections needing service negotiation	200
10.2.4.3.1	Symmetric connection	202
10.2.4.3.2	Asymmetric uplink connection	202
10.2.4.3.3	Asymmetric downlink connection	202
10.2.4.3.4	Connection established	203
10.2.5	Expedited connections	203
10.3	C/O connection modification	203
10.3.1	Advanced connection: bandwidth modification	203
10.3.1.1	Suspend and resume	205
10.3.1.1.1	Expedited suspend and resume	205
10.3.1.2	MAC resume paging	205
10.3.1.3	ULE resume paging	206
10.3.2	Advanced connection: service type or slot type modification	206
10.3.2.1	Procedure for service type modification	206
10.3.2.2	Procedures for slot type modification	207
10.3.2.2.1	Procedure for slot type modification full to double	207
10.3.2.2.2	Procedure for slot type modification double to full	208
10.3.2.2.3	Procedures for slot type modification to/from long	208
10.3.2.2.4	Procedure for slot type modification in multibearer connections	208
10.3.2.3	Procedure for ECN number modification in an advanced connection	209
10.3.3	Connection type modification	209
10.3.3.1	Procedure for connection type modification basic to advanced	210
10.3.3.1.1	General procedure	210
10.3.3.1.2	Procedure for connection type modification basic to advanced plus slot type modification full to double	210
10.3.3.1.3	Procedure for connection type modification basic to advanced plus slot type modification full to long	211
10.3.3.2	Procedure for connection type modification advanced to basic	211
10.3.4	Modulation type modification	211
10.3.4.1	Adaptive code rate	213
10.4	C/O connection release	213
10.4.1	General	213
10.4.1.1	C/O connection release in packet mode connections	214
10.4.2	Procedure description	214
10.5	C/O bearer setup	214
10.5.1	Single bearer setup procedures	214
10.5.1.1	Basic bearer setup procedure	215
10.5.1.2	A-field advanced single bearer setup procedure	217
10.5.1.2.1	PT initiated	217
10.5.1.2.2	FT initiated	220
10.5.1.3	B-field single bearer setup procedure	221
10.5.1.3.1	PT initiated	221
10.5.1.3.2	FT initiated	223
10.5.1.4	Double simplex setup procedure	223
10.5.1.4.1	Terminology and Predicates	223
10.5.1.4.2	General description	224
10.5.1.4.3	Channel selection procedure for circuit mode connections	225
10.5.1.4.4	Channel selection procedure for packet mode connections	225
10.5.1.4.5	Indirect setup procedure	226

10.5.1.4.6	Direct setup procedure.....	227
10.5.1.4.7	Handling of encrypted connections	230
10.5.1.5	Complementary connection bearer setup	231
10.5.1.6	Double duplex bearer setup procedure: Mapping procedure.....	232
10.5.1.7	Usage of TA special code "111" and M _T message "B-field setup, first PT transmission"	233
10.5.1.7.1	Default rules for TA code "111"	233
10.5.1.7.2	Default rules for M _T message "B-field setup, first transmission"	234
10.5.1.8	Expedited bearer setup procedures.....	234
10.5.1.8.1	General	234
10.5.1.8.2	Procedure for Single-burst setup and release.....	235
10.5.1.8.3	Procedure for Multi burst setup.....	236
10.5.1.8.4	Announcement "Ready for Release"	238
10.5.1.8.5	Indirect FT initiated expedited bearer setup procedure	239
10.5.1.8.6	Insertion of U-plane in "Expedited access request" messages.....	239
10.5.1.8.7	Connected state (TBC) in expedited bearer setup.....	239
10.5.1.8.8	Encryption synchronization in expedited bearer setup	240
10.5.1.8.9	Use of short slots in expedited connections.....	240
10.5.2	Channel list procedures.....	241
10.5.2.1	General	241
10.5.2.2	Description of the channel list messages.....	241
10.5.2.3	Usage of the channel list messages	242
10.6	C/O bearer handover	243
10.6.1	General.....	243
10.6.2	Duplex bearer handover procedure	244
10.6.3	Double simplex bearer handover	244
10.6.4	Bearer replacement	245
10.6.4.1	General bearer replacement.....	245
10.6.4.2	Frequency replacement	245
10.7	C/O bearer release	247
10.7.1	General.....	247
10.7.2	Bearer release procedure description	247
10.7.2.1	Unacknowledged release procedure.....	247
10.7.2.1.1	Crossed bearer release procedure	248
10.7.2.2	Acknowledged release procedure.....	248
10.7.2.3	Fast release procedure	248
10.7.2.4	REP relayed bearer release.....	249
10.7.3	Expedited bearer release procedures.....	249
10.7.3.2	General Expedited Release procedure.....	249
10.7.3.2.1	Procedure description	249
10.7.3.2.2	Exceptional cases and error handling	250
10.7.3.3	Special cases of expedited release procedures	251
10.7.3.3.1	Single-message expedited release procedure.....	251
10.7.3.3.2	Abnormal expedited release procedure.....	251
10.8	C/O data transfer	251
10.8.1	Higher layer associated signalling (C).....	251
10.8.1.1	C _S channel data	251
10.8.1.1.1	Transmission principle	252
10.8.1.1.2	Numbering principle.....	252
10.8.1.2	C _F channel data	252
10.8.1.2.1	Transmission principle	253
10.8.1.2.2	Numbering principle.....	253
10.8.1.3	Q1 and Q2 bit settings for all services except I _{p_error_correct}	253
10.8.1.3.1	Q1 and Q2 bit settings for MAC service I _N	253
10.8.1.3.2	Q1 and Q2 bit settings for MAC service I _{p_error_detect}	254
10.8.1.3.3	Q2 bit settings.....	254
10.8.1.3.4	Q1 bit settings.....	255
10.8.1.3.5	Q1 and Q2 settings when B-field is in E-mux modes.....	256
10.8.1.3.6	Q1 and Q2 settings when B-field is in "no-B-field" mode	257
10.8.1.3.7	Q1, Q2 and BCK settings when there are transitions in the coding rules or when the rules applicable to both directions are not the same	258
10.8.1.3.8	Q1 and Q2 settings when B-field mode is unknown	258

10.8.2	MOD-2 protected I channel operation (I_P).....	258
10.8.2.1	General.....	258
10.8.2.1.1	Use of selective reception.....	259
10.8.2.2	Limiting the lifetime of packets.....	259
10.8.2.2.1	Lifetime setting and management.....	259
10.8.2.3	A-field shall always be correct.....	261
10.8.2.4	Use of the acknowledge bits.....	261
10.8.2.4.1	Q2 and BCK bit setting for I_P _error_correction services.....	261
10.8.2.4.2	BCK bit setting.....	262
10.8.2.5	Data jump procedures.....	262
10.8.2.5.1	New MOD-2 numbering in case of Bearer replacement.....	262
10.8.2.5.2	Unilateral jump.....	262
10.8.2.5.3	MAC I_P bearer reset.....	264
10.8.2.6	Bearer handover and bearer replacement procedures.....	264
10.8.2.6.1	General.....	264
10.8.2.6.2	Bearer handover in a MOD-2 protected I channel.....	264
10.8.2.6.3	Bearer replacement in a MOD-2 protected I channel.....	265
10.8.2.7	Exchange of data from/to higher layers.....	265
10.8.2.7.1	Operation if I_{PF} channel is supported.....	266
10.8.3	Higher layer unprotected information (I_N) and MAC_error_detection services (I_P).....	266
10.8.3.1	I_N _minimum_delay service (I_{NA}).....	266
10.8.3.2	I_N _normal_delay service (I_{NB}).....	266
10.8.3.3	I_P _error_detection service.....	267
10.8.3.3.1	Operation if I_{PF} channel is supported.....	267
10.8.3.4	I_P _encoded_protected service (I_{PX}).....	267
10.8.4	Higher layer U-plane channel (I_{PF}) in E+U type mux.....	267
10.8.4.1	Purpose of the I_{PF} channel.....	267
10.8.4.2	Activation of the E+U type mux mode.....	268
10.8.4.3	I_{PF} procedures.....	268
10.8.4.3.1	I_{PF} basic procedures.....	268
10.8.4.3.2	I_{PF} advanced procedures.....	269
10.8.4.3.3	Special case: slots not multiple of 64 bits.....	269
10.8.4.4	I_{PF} Mod-2 protected operation.....	270
10.8.4.5	I_{PF} _error_detect operation.....	270
10.8.4.6	I_{PF} _operation with I_N service.....	270
10.8.4.7	Backcompatibility rule.....	271
10.9	C/O procedures for FT connections with CRFP.....	271
10.9.1	Dual C/O bearer setup.....	271
10.9.2	C/O connection release of connection with CRFP.....	271
10.9.3	C/O connection suspend and resume.....	271
11	Medium access layer management procedures.....	272
11.1	Broadcasting.....	272
11.1.1	RFP transmission.....	272
11.1.2	PP reception.....	272
11.2	Extended system information.....	272
11.2.1	PP requests.....	272
11.2.2	RFP response.....	272
11.3	PP states and state transitions.....	272
11.3.1	Actions in Idle_Unlocked and Active_Unlocked states.....	272
11.3.2	Entry into the Idle_Locked state.....	273
11.3.3	Actions in the Idle_Locked state.....	273
11.3.3.1	Page detection in Idle_Locked state.....	273
11.3.3.2	Setup detection in Idle_Locked state.....	274
11.3.4	Idle_Locked and Active_Locked state transitions.....	275
11.4	Physical channel selection.....	275
11.4.1	The channel selection lists.....	275
11.4.2	Physical channel and RFP selection at the PP.....	277
11.4.3	Physical channel selection at the RFP.....	278
11.4.4	Hand over criteria due to in-connection base identification.....	280
11.4.5	Handover criteria due to interference.....	280

11.4.6	Exception in channel selection rules for Ultra Low Energy devices	281
11.5	In-connection quality control	281
11.5.1	RFPI handshake	281
11.5.2	Frequency control	281
11.5.2.1	RFP measurement of frequency error	281
11.5.2.2	PT frequency correction	281
11.6	Maximum allowed system load at RFPs	281
11.7	PMID and FMID definitions	281
11.7.1	FMID definition	281
11.7.2	PMID definition	282
11.7.2.1	'X'PMID definition	282
11.8	RFP idle receiver scan sequence	282
11.9	PT receiver scan sequence	283
11.10	Management of connections associated with Broadband data links	283
11.11	Management procedures for "no-emission" mode	283
11.11.1	Behaviour during "no-emission" mode	284
11.12	Physical channel selection procedures for DECT Ultra Low Energy (ULE)	284
11.12.1	General	284
11.12.2	Overall architecture of ULE channel selection processes	284
11.12.3	Process M0 (RFP side pre-selection process)	285
11.12.4	Broadcast mechanism	285
11.12.5	Process M1 (PP side channel selection process)	286
11.12.6	Setup attempt and evaluation of responses	287
11.12.7	Process M2 (collision handling/collision avoidance process)	288
11.12.7.1	Equations	289
11.12.7.2	Algorithm	289
12	Medium access layer test message procedure	289
12.1	Introduction	289
12.2	General	290
12.2.1	Portable part testing	291
12.2.2	Fixed part testing	291
12.2.3	Applicability of test messages	291
12.3	FORCE_TRANSMIT	292
12.3.1	Portable part	292
12.3.2	Fixed part	292
12.4	LOOPBACK_DATA	293
12.4.1	Portable part	293
12.4.2	Fixed Part	293
12.4.2.1	IUTs implementing the DECT scrambler	293
12.4.2.2	IUTs implementing a proprietary scrambler	293
12.5	DEFEAT_ANTENNA_DIVERSITY	293
12.6	NETWORK_TEST	294
12.7	ESCAPE	294
12.8	CLEAR_TEST_MODES	294
12.9	CHANGE_MODULATION_SCHEME	294
Annex A (normative):	MAC layer timers and constants	295
A.1	Timers and Time Windows	295
A.2	Constants	295
A.2.1	Constants for the ULE channel selection algorithms	296
Annex B (informative):	Construction of the CRC polynomial and error detecting performance	297
Annex C (informative):	MAC relationship to other layers	298
Annex D (informative):	Synchronization	299
Annex E (normative):	Scrambling patterns	300

Annex F (informative):	Seamless handover operation	301
F.1	I channel data flow for I _N _minimum_delay service	301
Annex G (normative):	Requirements for PPs with direct PP to PP communication mode.....	302
G.1	Description of operation in direct PP to PP communication mode	302
G.2	Requirements.....	303
G.2.1	Setting the PP in direct communications mode	303
G.2.2	Specific Alternative 1 requirements	303
G.2.2.1	When the PP has not initiated a call.....	303
G.2.2.2	When the PP initiates a call	303
G.2.3	Specific Alternative 2 Requirements.....	304
Annex H (normative):	Requirements for FPs with Wireless FT to FT (W-FT2FT) communication mode.....	305
H.1	Introduction	305
H.2	Description of operation in W-FT2FT communication mode.....	306
Annex I (normative):	Channel coding and Modulation	307
I.1	Channel coding.....	308
I.1.1	The parallel Turbo Code Principle	308
I.1.2	The FOCTC implementation.....	308
I.1.2.1	The FOCTC concept.....	308
I.1.2.2	The FOCTC structure and the component code.....	309
I.1.2.3	The FOCTC Inner interleaving algorithm	311
I.1.2.4	FOCTC Inner interleaving size adaptation to all Physical Packet Formats	312
I.2	Adaptive coding and Modulation Embodiment.....	314
I.2.1	Adaptive code rates	314
I.2.1.1	Adaptive code rates for the double slot structure (physical packet P80)	315
I.2.1.2	Adaptive code rates for the full slot structure (physical packet P32).....	316
I.2.1.3	Adaptive code rates for the half slot structure (physical packet P00j with j=80).....	316
I.2.2	Puncturing patterns.....	317
I.2.3	Channel Capacity for the B-field map configurations	318
I.2.3.1	Double Slot Structure.....	318
I.2.3.2	Full Slot Structure.....	319
I.2.3.3	Half Slot Structure	320
I.3	Change Modulation Scheme	320
I.4	B-Field Binary Interleaving.....	320
I.4.1	General description.....	320
I.4.2	Mathematical Description	322
I.4.2.1	L(k) Expression	322
I.4.2.2	Interleaving Spreading $\Delta L(s)$ Expression	323
I.4.3	B-field binary interleaving parameters	324
I.4.3.1	Physical packet Format P80 (double slot structure).....	324
I.4.3.2	Physical packet Format P32 (full slot structure).....	325
I.4.3.3	Physical packet Format P00j with j=80 (Half-Slot structure).....	325
Annex J (informative):	Channel decoding.....	326
Annex K (informative):	Additional information on MAC messages.....	327
K.1	Historic use of some MAC service codes.....	327
Annex L (informative):	Bibliography.....	328
Annex M (informative):	Change history	329
History		330

Intellectual Property Rights

IPRs essential or potentially essential to the present document may have been declared to ETSI. The information pertaining to these essential IPRs, if any, is publicly available for **ETSI members and non-members**, and can be found in ETSI SR 000 314: "*Intellectual Property Rights (IPRs); Essential, or potentially Essential, IPRs notified to ETSI in respect of ETSI standards*", which is available from the ETSI Secretariat. Latest updates are available on the ETSI Web server (<http://ipr.etsi.org>).

Pursuant to the ETSI IPR Policy, no investigation, including IPR searches, has been carried out by ETSI. No guarantee can be given as to the existence of other IPRs not referenced in ETSI SR 000 314 (or the updates on the ETSI Web server) which are, or may be, or may become, essential to the present document.

Foreword

This draft European Standard (EN) has been produced by ETSI Technical Committee Digital Enhanced Cordless Telecommunications (DECT), and is now submitted for the combined Public Enquiry and Vote phase of the ETSI standards EN Approval Procedure.

The present document is part 3 of a multi-part deliverable ([1] to [8]). Full details of the entire series can be found in part 1 [1].

Further details of the DECT system may be found in TR 101 178 [i.1] and ETR 043 [i.2].

Proposed national transposition dates	
Date of latest announcement of this EN (doa):	3 months after ETSI publication
Date of latest publication of new National Standard or endorsement of this EN (dop/e):	6 months after doa
Date of withdrawal of any conflicting National Standard (dow):	6 months after doa

1 Scope

The present document is one of the parts of the specification of the Digital Enhanced Cordless Telecommunications (DECT) Common Interface (CI).

The present document specifies the Medium Access Control (MAC) layer. The MAC layer is part 3 of the DECT Common Interface standard and layer 2a of the DECT protocol stack.

It specifies three groups of MAC services:

- the broadcast message control service;
- the connectionless message control service; and
- the multi-bearer control service.

It also specifies the logical channels that are used by the above mentioned services, and how they are multiplexed and mapped into the Service Data Units (SDUs) that are exchanged with the Physical Layer (PHL).

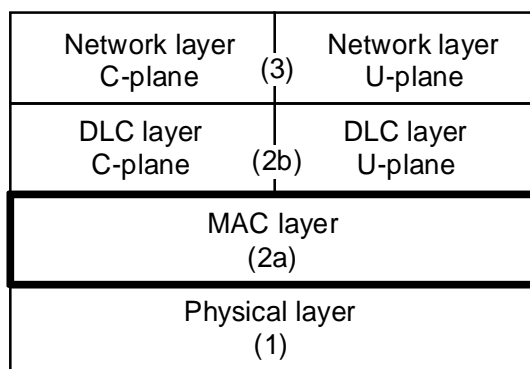

Figure 1.1: The DECT protocol stack

The present document includes New Generation DECT, a further development of the DECT standard introducing wideband speech, improved data services, new slot types and other technical enhancements.

2 References

References are either specific (identified by date of publication and/or edition number or version number) or non-specific. For specific references, only the cited version applies. For non-specific references, the latest version of the reference document (including any amendments) applies.

Referenced documents which are not found to be publicly available in the expected location might be found at <http://docbox.etsi.org/Reference>.

NOTE: While any hyperlinks included in this clause were valid at the time of publication ETSI cannot guarantee their long term validity.

2.1 Normative references

The following referenced documents are necessary for the application of the present document.

- [1] ETSI EN 300 175-1: "Digital Enhanced Cordless Telecommunications (DECT); Common Interface (CI); Part 1: Overview".
- [2] ETSI EN 300 175-2: "Digital Enhanced Cordless Telecommunications (DECT); Common Interface (CI); Part 2: Physical Layer (PHL)".

- [3] Void.
- [4] ETSI EN 300 175-4: "Digital Enhanced Cordless Telecommunications (DECT); Common Interface (CI); Part 4: Data Link Control (DLC) layer".
- [5] ETSI EN 300 175-5: "Digital Enhanced Cordless Telecommunications (DECT); Common Interface (CI); Part 5: Network (NWK) layer".
- [6] ETSI EN 300 175-6: "Digital Enhanced Cordless Telecommunications (DECT); Common Interface (CI); Part 6: Identities and addressing".
- [7] ETSI EN 300 175-7: "Digital Enhanced Cordless Telecommunications (DECT); Common Interface (CI); Part 7: Security features".
- [8] ETSI EN 300 175-8: "Digital Enhanced Cordless Telecommunications (DECT); Common Interface (CI); Part 8: Speech and audio coding and transmission".
- [9] ETSI EN 301 649: "Digital Enhanced Cordless Telecommunications (DECT); DECT Packet Radio Service (DPRS)".
- [10] ETSI EN 300 176-1: "Digital Enhanced Cordless Telecommunications (DECT); Test specification; Part 1: Radio".

2.2 Informative references

The following referenced documents are not necessary for the application of the present document but they assist the user with regard to a particular subject area.

- [i.1] ETSI TR 101 178: "Digital Enhanced Cordless Telecommunications (DECT); A High Level Guide to the DECT Standardization".
- [i.2] ETSI ETR 043: "Digital Enhanced Cordless Telecommunications (DECT); Common Interface (CI); Services and facilities requirements specification".
- [i.3] W.W. Peterson and E.J. Weldon (1972, 2nd edition): "Error Correcting Codes" (MIT Press, Cambridge, MA).
- [i.4] Berrou, Glavieux and Thitimajshima: "Near Shannon limit error-correcting coding and decoding: Turbo Codes", Proceedings of the ICC conference, May 1993.
- [i.5] Berrou and Jézéquel: "Frame-oriented convolutional turbo codes", Electronic Letters, Vol. 32, N 15, pp. 1362-1364, July 1996.
- [i.6] P. Robertson, P. Hoeher and E. Villebrun: "Optimal and sub-optimal maximum a posteriori algorithms suitable for turbo decoding", European Trans. Commun., Vol. 8, N 2, pp. 119-125, March-April 1997.
- [i.7] I. Siaud: "On COFDM performance of Digital Radio Systems in AM and HF bands over multipath ionospheric channels", Nordic HF'01 Conference, 14-16 August 2001, Fåro.
- [i.8] ETSI EN 300 444: "Digital Enhanced Cordless Telecommunications (DECT); Generic Access Profile (GAP)".
- [i.9] Siaud, I., Ulmer-Moll A.M.: "Turbo-like Processing for Scalable Interleaving Pattern Generation: application to 60 GHz UWB-OFDM systems", ICUWB'07, Singapore, September 2007.
- [i.10] ETSI TS 102 939-1: "Digital Enhanced Cordless Telecommunications (DECT); Ultra Low Energy (ULE); Machine to Machine Communications; Part 1: Home Automation Network (phase 1)".
- [i.11] ETSI TS 102 527-4: "Digital Enhanced Cordless Telecommunications (DECT); New Generation DECT; Part 4: Light Data Services; Software Update Over The Air (SUOTA), content downloading and HTTP based applications".

3 Definitions, symbols and abbreviations

3.1 Definitions

For the purposes of the present document, the terms and definitions given in EN 300 175-1 [1] apply.

3.2 Symbols and abbreviations

For the purposes of the present document, the symbols and abbreviations given in EN 300 175-1 [1] and the following apply:

A-MAP	A-field MAP
ARI	Access Rights Identity
ARQ	Automatic Repeat reQuest
B-MAP	B-field MAP
BMC	Broadcast Message Control
B _S	slow Broadcast channel
B _U	ULE Broadcast channel
C	higher layer control Channel (see C _S and C _F)
CBC-MAC	Cipher Block Chaining Message Authentication Code
C/L	ConnectionLess
C/O	Connection Oriented
CBC	Connectionless Bearer Control
CCF	Cluster Control Function
CCM	Counter with CBC-MAC (see EN 300 175-7 [7])
C _F	higher layer signalling Channel (fast)
CI	Common Interface (standard)
CL	higher layer Connectionless channel (protected; see CL _S and CL _F)
CL _F	higher layer Connectionless channel (fast)
CL _S	higher layer Connectionless channel (slow)
CMC	Connectionless Message Control
CN	Carrier Number
C-plane	Control plane
CRC	Cyclic Redundancy Check
CRFP	Cordless Radio Fixed Part
C _S	higher layer signalling Channel (slow)
CSF	Cell Site Functions
C _T	one C _S or CL _S channel segment
CTA	Cordless Terminal Adapter
DBC	Dummy Bearer Control
DLC	Data Link Control
D-MAP	D-field MAP
DPRS	DECT Packet Radio Service
DQPSK	Differential Quaternary Phase Shift Keying
E type	B-field multiplexer mode when the slot carries signalling only (channels C _F , G _F and M)
E/U-mux	B-field multiplexer (switching between E, U or E+U modes)
E+U type	B-field multiplexer mode when the slot carries U-plane data (channel I _{PF}) AND signalling (channels G _F and M)
ECN	Exchanged Connection Number
EUT	Equipment Under Test
FMID	Fixed part MAC IDentity
FOCTC	Frame Oriented Convolutional Turbo-code
FP	Fixed Part
FT	Fixed radio Termination
GAP	Generic Access Profile
G _F	higher layer information control channel (fast), (a logical channel to the MAC layer)

G _{FA}	higher layer information control channel (slow), (a logical channel to the MAC layer)
HD	Handover Disable
HLM	High Level Modulation
I	higher layer Information channel (see I _N and I _P) in general
I _N	higher layer Information channel unprotected (in general, any variant)
I _{NA}	higher layer Information channel unprotected, minimum delay operation
I _{NB}	higher layer Information channel unprotected, normal delay operation
I _P	higher layer Information channel protected (in general, any variant)
I _{PF}	higher layer Information channel protected, transported multiplexed with signalling in the E+U type slots
I _{PK}	higher layer Information channel protected, with constant-size subfield format
I _{PKR}	higher layer Information channel protected, with constant-size subfield format and error correction
I _{PM}	higher layer Information channel protected, with multi subfield format
I _{PMR}	higher layer Information channel protected, with multi subfield format and error correction using MOD-2 retransmission mechanism
I _{PQ}	higher layer Information channel protected, with single subfield format
I _{PQR}	higher layer Information channel protected, with single subfield format and error correction using MOD-2 retransmission mechanism
I _{PX}	higher layer Information channel, encoded protected, minimum delay operation
IRC	Idle Receiver Control
IUT	Implementation Under Test
KSG	Key Stream Generator
LBN	Logical Bearer Number
LLME	Lower Layer Management Entity
LSB	Least Significant Bit
LT	Lower Tester
M	MAC control channel in general (on A-tail or B fields)
M0	RFP channel pre-selection algorithm for ULE
M1	PP channel selection algorithm for ULE
M2	PP collision handling and avoidance algorithm for ULE
MAC	Medium Access Control layer
MAP	bit MAPpings
MBC	Multi-Bearer Control
MCEI	MAC Connection Endpoint Identification
ME	Management Entity
MSB	Most Significant Bit
M _T	MAC control channel on A-tail field, or one message on such channel
M _U	MAC control channel on B-field for ULE
MUX	time MULTipleXors
N	identities channel
N _S	Split identities channel on B-field for ULE
N _T	identities information, one N channel message
P	Paging channel
PHL	PHysical Layer
PMID	Portable part MAC IDentity
PP	Portable Part
PSCN	Primary Receiver Scan Carrier Number
P _T	one P channel message
PT	Portable radio Termination
P _U	ULE Paging channel on B-field
Q	system information channel
Q _C	Compound System Information Channel of B-field for ULE
Q _T	system information and multiframe marker
REP	REpeater Part
RFP	Radio Fixed Part
RFPI	Radio Fixed Part Identity
RPN	Radio fixed Part Number

RSC	Recursive Systematic Convolutional (code)
SAP	Service Access Point
SDU	Service Data Unit
SI _N	higher layer connectionless channel (Unprotected)
SI _P	higher layer connectionless channel (Protected)
SI _{PF}	higher layer connectionless channel (protected) transported multiplexed with signalling in the E+U type slots
SN	Slot Number
TBC	Traffic Bearer Control
TDM	Time Division Multiplex
TDMA	Time Division Multiple Access
T-MUX	Tail-MUX
U type	B-field multiplexer mode when the slot carries U-plane data only (channels I _N or I _P)
U-plane	User plane
ULE	Ultra Low Energy
WRS	Wireless Relay Station

4 Description of the MAC layer

4.1 MAC layer reference model

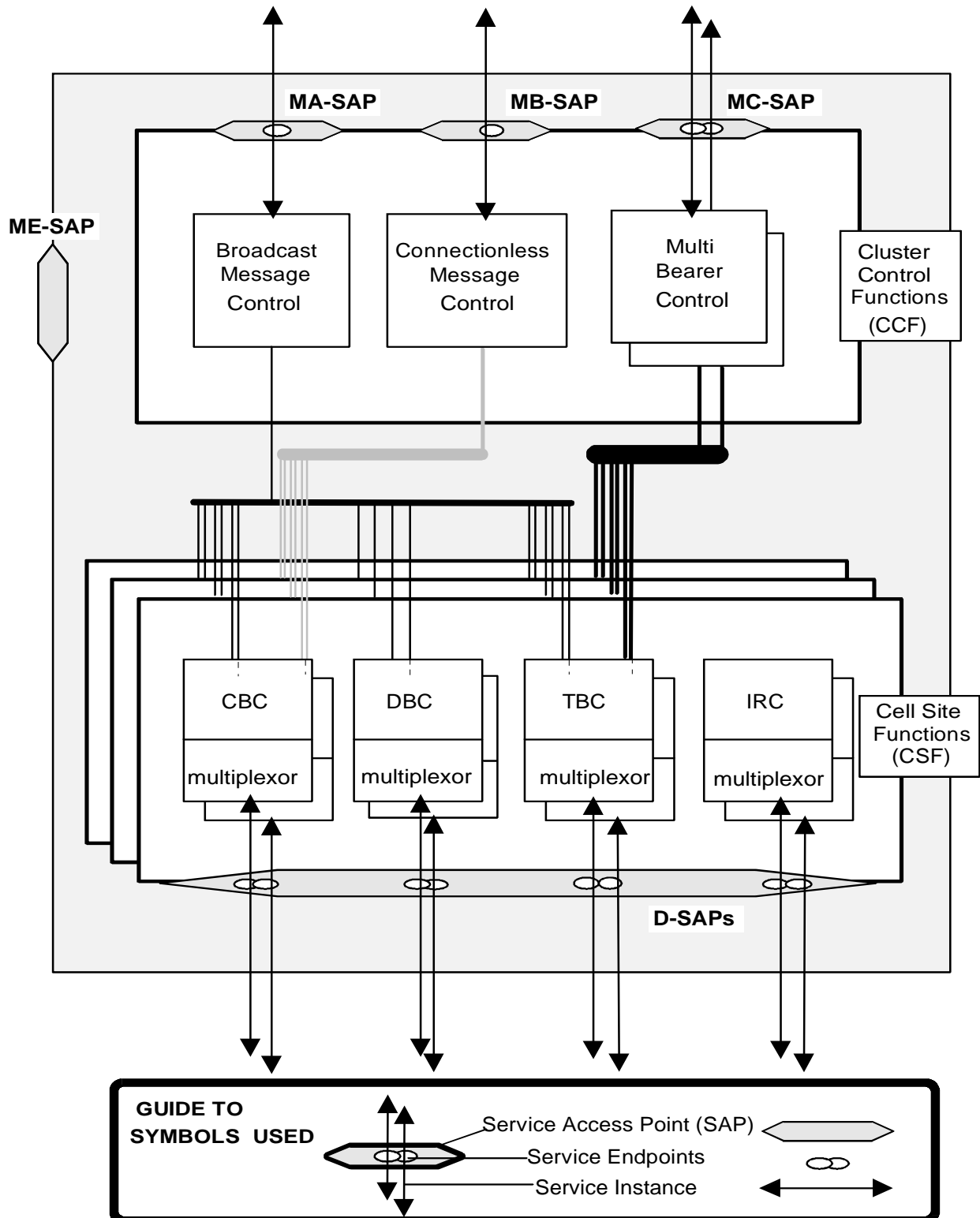

NOTE: MA, MB, MC and D are Service Access Points (SAPs) between the adjacent layers. Each line through these SAPs represents an independent service instance. ME is a SAP to the management entity.

Figure 4.1: MAC reference model

4.1.1 General

As far as possible, the present document avoids defining specific physical architectures, and uses the MAC reference model shown in figure 4.1. This reference model architecture applies equally to both the FT and the PT.

NOTE: The terms "FT" and "PT" used throughout the present document apply also for implementations that combine FT and PT protocol elements, e.g. terminals that support PT-to-PT, distributed or FT2FT communication. Consequently, in every particular situation the used term should be understood as to refer to a terminal that exercises the particular behaviour.

There is always a single instance of cluster control function that controls all instances of the cell site functions. In the FT, multiple cells would require multiple instances of CSFs (one per cell). Each of these instances connects to an independent physical layer via an independent D-SAP.

The multiplexor shown at the bottom of all CSFs is described in clause 6.

4.1.2 Cluster Control Function (CCF)

This includes all the MAC functions that are used to control more than one cell. A cluster contains only one CCF. The CCF contains the following functional elements:

- **BMC (Broadcast Message Control):** the functions that control and distribute the cluster's broadcast information to/from all CBCs, TBCs and DBCs. There is only one BMC per CCF.
- **CMC (Connectionless Message Control):** the functions that control and distribute the information of all connectionless services to one or more CBCs (see clause 5.7 for a description of connectionless services). There is at most one CMC per CCF.
- **MBC (Multi-Bearer Control):** the functions that control the multiplexing and management of all the data directly associated with a MAC connection between one FT and one PT. For single bearer connections (when not performing bearer handover) an MBC only manages one TBC, for multi-bearer connections an MBC will manage several TBCs. There is always only one MBC per connection, and therefore a CCF can contain multiple instances of MBCs (see clauses 5.5 and 5.6 for a description of bearers and connections).

4.1.3 Cell Site Functions (CSF)

This includes all the functions that are concerned with only one cell. Each CSF contains the following functional elements:

- **Connectionless Bearer Control (CBC):** the functions that control a connectionless bearer. Each CSF may contain multiple instances of CBC (see clauses 5.7 and 5.7.2.1).
- **Dummy Bearer Control (DBC):** the functions that control one dummy bearer. There is a maximum of two DBCs per CSF (see clause 5.7).
- **Traffic Bearer Control (TBC):** the functions that control one traffic bearer. Each CSF may contain multiple instances of TBC.
- **Idle Receiver Control (IRC):** the functions that control the receiver when not involved with a bearer. Each CSF may contain multiple instances of IRC.

Refer to clause 5.5.2 for descriptions of dummy bearer, traffic bearer, and connectionless bearer.

4.1.4 Relationship to physical layer elements

A TBC controls one duplex bearer or one double simplex bearer. It, therefore, controls two physical channels.

A DBC controls one simplex bearer and, therefore, controls one physical channel.

A CBC controls either a simplex or a duplex bearer and, therefore, may control one or two physical channels.

The IRC may control all of the radio transceivers (for one cell) on any of the available physical channels that are not being used by the other entities (TBC, DBC or CBC). This provides various scanning functions defined in clauses 11.3.2, 11.4.1 and 11.8.

Each instance of the cell site functions relates to one physical cell, and thereby to a single PHL instance, as shown in figure 4.2.

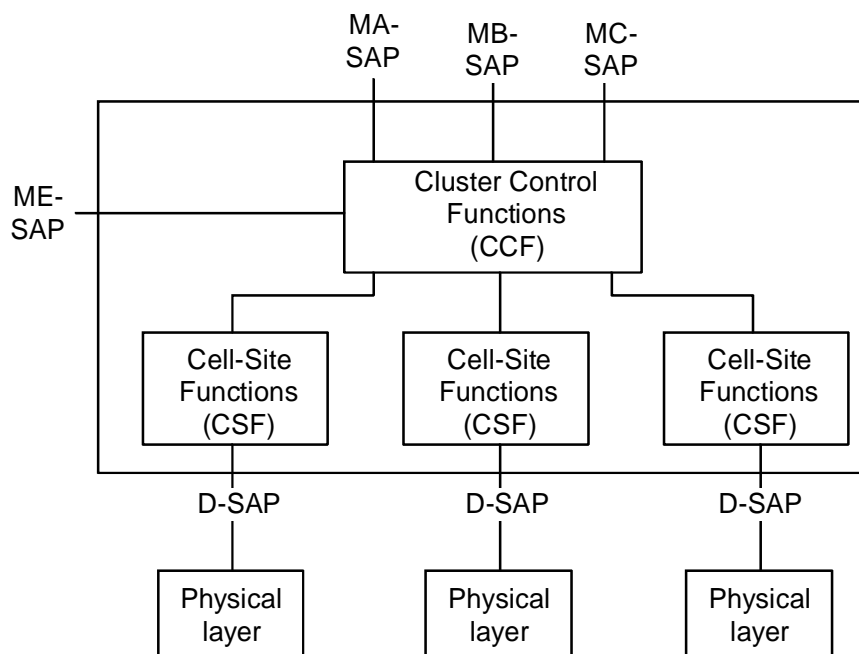

Figure 4.2: One MAC cluster

This expanded architecture is only significant for the FT. However, the physical groupings of any particular FT implementation may not correspond to these functional groupings, and the MAC architecture is arranged to allow many alternative implementations. For example, manufacturers may choose to implement a single cluster or multiple clusters. In both cases they may choose to distribute everything, to centralize just the cluster control functions or to centralize both the CCF and the CSF. Intermediate physical groupings may be possible for some implementations.

4.2 Frame and multiframe structures

4.2.1 General

There are two hierarchical levels of time division multiplexing:

- frame: a time division multiplex of slots;
- multiframe: a time division multiplex of frames.

Timing is defined by the FP transmissions, and the PP is required to slave all of its transmissions to these timings.

Detailed frame timing is defined by the PHL, but slot numbering is defined by the MAC layer.

Multiframe timing is wholly defined by the MAC layer.

4.2.2 Frame structure

A regular Time Division Multiple Access (TDMA) structure is created by the PHL (see EN 300 175-2 [2]). This frame defines 24 full-slot positions. Alternatively, each full-slot may be further divided into two half-slots, or two consecutive full slots may be used together as a double slot (see figures 4.3, 4.4 and 4.5), or as a long slot.

NOTE: Long slot uses variable capacity physical packet P00j with $j=640/672$ (see EN 300 175-2 [2], clause 4.4.3).

The MAC layer controls the transmission and/or reception of data for every double, full or half slot, by issuing primitives to the PHL. Each primitive specifies the operation for one slot position. Continuous operation on a given physical channel requires a regular series of primitives.

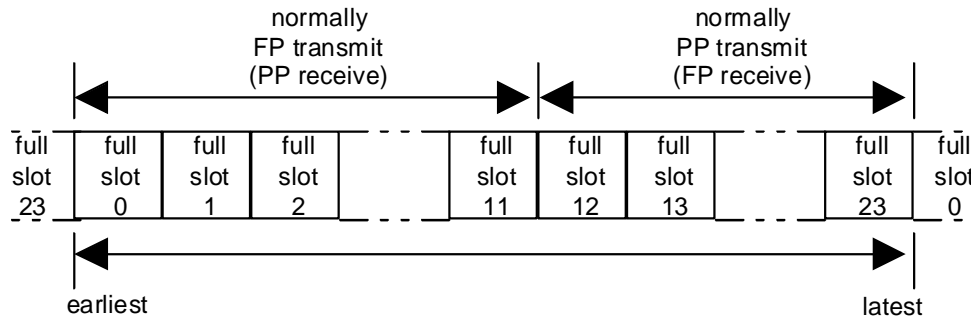

Figure 4.3: Full Slots

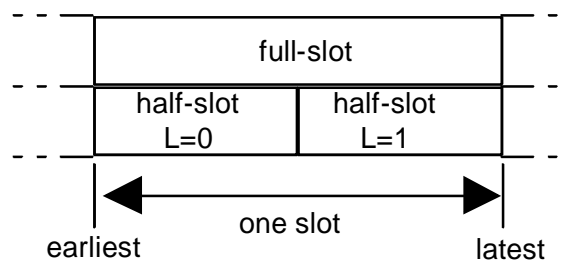

Figure 4.4: Half Slots

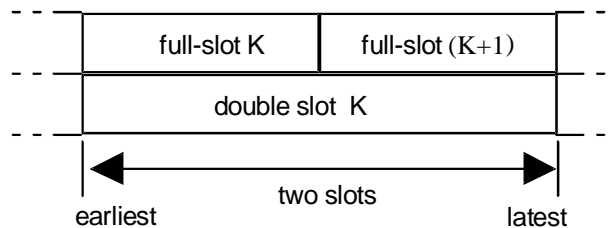

Figure 4.5: Double Slots

Full-slots are numbered from $K = 0$ to 23, and half-slots are numbered $L = 0$ or 1, where half-slot 0 occurs earlier than half-slot 1. Double slots are numbered from $K = 0$ to 22; there is no $K = 11$.

Normally full slots $K = 0$ to 11 are used in the FP to PP direction, and slots $K = 12$ to 23 in the PP to FP direction. Normally double slots $K = 0$ to 10 are used in the FP to PP direction, and double slots $K = 12$ to 22 in the PP to FP direction.

Slot numbers (frame timing) are not included in every slot transmission. Slot numbers are only defined in a special (Q channel) message that is transmitted at a low rate by all FPs. This message defines the actual slot number for that transmission (see clause 7.2.3).

This also applies to a PP acting as the RFP in PP-to-PP direct communication mode.

4.2.3 Multiframe structure

The MAC layer superimposes a multiframe structure on the TDMA frame structure. This is a Time Division Multiplex (TDM) of 16 frames. The multiframe starts and ends on a frame boundary, as shown in figure 4.6.

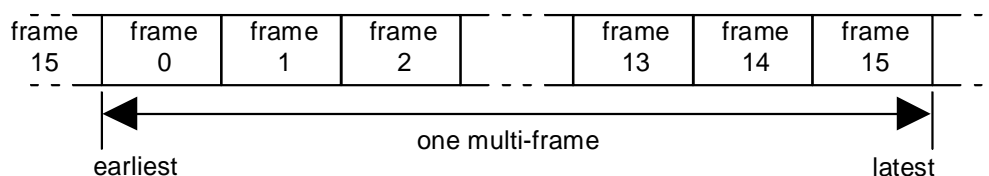

Figure 4.6: Multiframe

The multiframe numbering is defined in the same way for the FP and the PP. A multiframe normally starts with FP transmissions (first half of frame 0) and ends with PP transmissions (last half of frame 15).

Frame numbers (multi-frame timing) are never included in a transmission. Frame numbers shall be interpolated from the multiframe marker that is included in all FP transmissions. This marker appears once per multiframe (in frame 8) (see clauses 6.2.2.1 and 7.2.3).

When encryption is provided, an explicit multiframe number is also defined using a similar technique to slot numbering:

- a special (Q channel) message is transmitted at a low rate by the FP. This message defines the actual multiframe number for that transmission (see clause 7.2.3).

4.3 State definitions

4.3.1 PP states

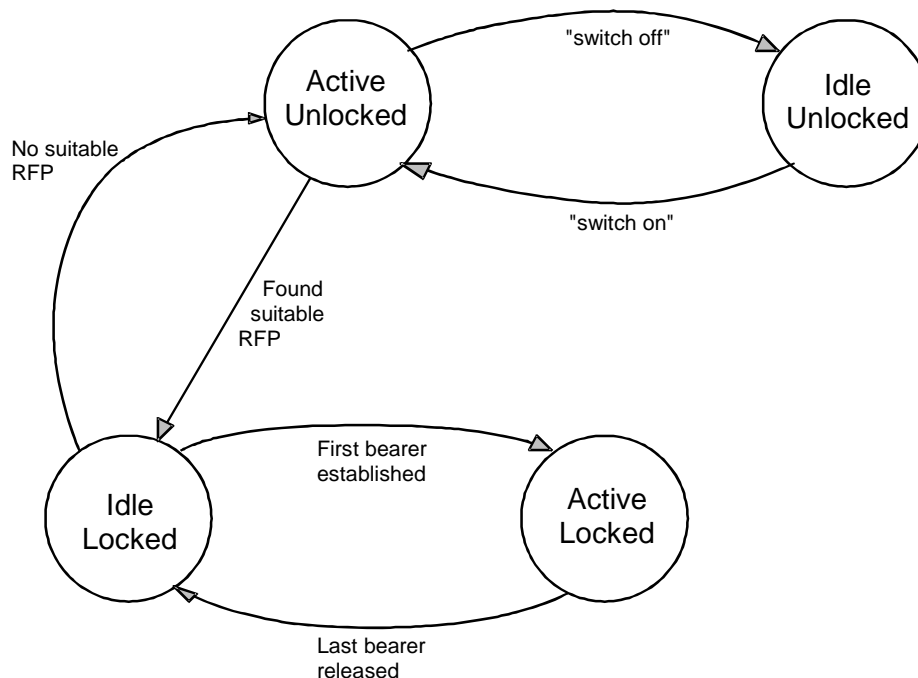

Figure 4.7: PP state diagram

A PP can exist in one of four major states at the MAC layer:

- 1) **Active_Locked:** where the PP is synchronized to at least one RFP transmission and has one or more connections in progress.

- 2) **Idle_Locked:** where the PP is synchronized to at least one RFP transmission. It is able to make or receive connections, but has no connections in progress.
- 3) **Active_Unlocked:** where the PP is not synchronized to any RFP transmissions, and is unable to make or receive connections. The PP makes occasional attempts to detect a suitable RFP and enter the Idle_Locked state.
- 4) **Idle_Unlocked:** the PP is not synchronized to any RFP and does not attempt to detect RFPs.

Several different modes of operation exist in the Idle_Locked state:

- a) **scanning mode:** where the PP's receiver scan sequence is synchronized with that of the RFP.
- b) **high duty cycle Idle_Locked mode:** where the PP receives 6 times per multiframe.
- c) **normal Idle_Locked mode:** where the PP typically receives once per multiframe.
- d) **low duty cycle Idle_Locked mode:** where the PP typically receives less than once per multiframe.

4.3.2 RFP states

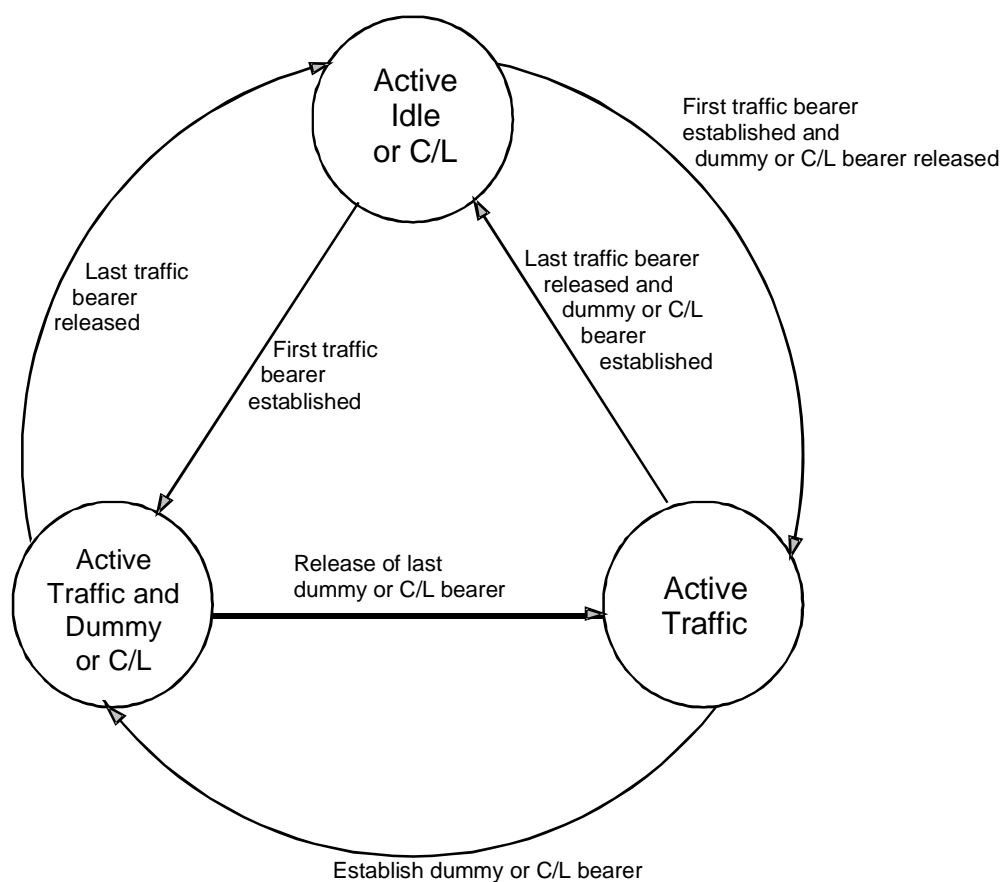

Figure 4.8: RFP state diagram

An RFP can exist in one of four major states at the MAC layer:

- 1) **Inactive:** where the RFP is not receiving or transmitting.

NOTE: The inactive state is not shown in the state diagram of figure 4.8.

- 2) **Active_Idle or C/L:** where the RFP has either at least one dummy bearer or at least one connectionless downlink bearer, and a receiver that is scanning the physical channels in a known sequence.
- 3) **Active_Traffic:** where the RFP has at least one traffic bearer, but does not have a dummy or a connectionless downlink bearer.

- 4) **Active_Traffic_and_Dummy or C/L:** where the RFP has at least one traffic bearer and is also maintaining one dummy or connectionless downlink bearer.

5 Overview of MAC layer services

5.1 General

The MAC layer offers three groups of services to the upper layers and to the management entity. These service groupings are related to the functional groupings in the cluster control functions:

- broadcast message control;
- connectionless message control;
- multi-bearer control.

Each individual service is accessed via an independent service endpoint, and these endpoints are grouped into three Service Access Points (SAPs). Each service endpoint contains one or more logical channels. A fourth group of logical channels is provided for internal (peer-to-peer) MAC control information. The logical channels are described in clause 5.3 and the SAPs are described in clause 5.4.

5.1.1 Broadcast Message Control (BMC)

The BMC provides a set of continuous point-to-multipoint connectionless services. These are used to carry internal logical channels, and are also offered to the higher layers via the MA-SAP. These services operate in the direction FT to PT, and are available to all PTs within range.

The BMC services may appear alone, but they also appear combined with any of the other services, thereby producing bearers that contain data from two services (i.e. a single physical packet contains fields carrying information from two services).

5.1.2 Connectionless Message Control (CMC)

The CMC provides connectionless point-to-point or point-to-multipoint services to the higher layers via the MB-SAP. These services may operate in both directions between one specific FT and one or more PTs.

5.1.3 Multi-Bearer Control

Each instance of MBC provides one of a set of connection oriented point-to-point services to the higher layers via the MC-SAP. These services may operate in both directions or in one direction between one specific FT and one specific PT. Each service instance provides a connection (a connection oriented service) between one FT and one PT.

An MBC service may use more than one bearer to provide a single service. In this event, these multiple bearers may be used to carry duplicated data (to provide redundancy) and/or distributed data (to provide increased bandwidth).

5.2 Service descriptions

5.2.1 Common functions

All the services provide the following functions:

- a) the means to monitor signal quality;
- b) the means to provide error control for some data.

5.2.2 BMC service

The BMC service provides two types of broadcast information in the direction FT to PT:

- permanent broadcasts containing the two MAC control channels, Q and N (see clauses 5.3.4.1 and 5.3.4.2);
- transient broadcasts containing the MAC paging channel, B_S (see clause 5.3.3.1).

The BMC service provides the following additional functions to the PT:

- a) the means to acquire and maintain frame and multiframe synchronism between transmitters and receivers;
- b) the means to obtain primary and secondary access right identities;
- c) the means to supply paging messages to the higher layers.

5.2.3 CMC service

The CMC service provides two alternative services:

- higher layer connectionless C-plane information, using the CL_S and CL_F channels (see clause 5.3.2.1);
- higher layer connectionless U-plane information, using the SI_N and the SI_P channels (see clause 5.3.2.2).

A single CCF may contain one single CMC instance. This CMC instance cannot be combined with an MBC connection service.

The CMC service provides the following additional function:

- the means to multiplex more than one logical channel onto each MAC bearer of the broadcast, with defined priorities.

5.2.4 MBC services

Each MBC instance can provide two separate connection oriented services to the higher layer:

- higher layer C-plane information, contained in the C channels (see clause 5.3.1.1);
- higher layer U-plane information contained in the I and G_F channels (see clauses 5.3.1.2 and 5.3.1.3).

These two services are independent, and may be provided in combination or separately as part of a given MBC service. The overall service may be bidirectional, or unidirectional (in either direction). The chosen service type(s) and the service directions are defined during MBC connection establishment.

Each MBC service provides the following additional functions:

- a) the means to set-up, maintain and clear down a variety of different connections using one or more bearers (duplex bearers and/or double simplex bearers);
- b) the ability to preserve connection quality by performing individual "bearer handover" or "bearer replacement" of any duplex or double simplex bearers;
- c) the means to multiplex more than one logical channel onto each MAC bearer of the connection, with defined priorities;
- d) the means to encrypt optionally all higher layer data.

5.3 Logical channels

The following logical channels are defined:

- a) MBC connection endpoints (MC-SAP logical channels):
 - C channels: C_S and C_F ;
 - I channels: I_N and I_P ;
 - G_F and G_{FA} channels.
- b) CMC service endpoint (MB-SAP logical channels):
 - CL channels: CL_S and CL_F ;
 - SI_N channel and SI_P channel.
- c) BMC broadcast endpoint (MA-SAP logical channel):
 - B_U channel;
 - B_S channel.
- d) Internal MAC control channels:
 - Q channel;
 - N channel;
 - M channel;
 - P channel;
 - Q_C channel;
 - N_S channel;
 - M_U channel;
 - P_U channel.

5.3.1 MBC connection endpoints (MC-SAP logical channels)

5.3.1.1 The higher layer C-plane channels, C

Higher layer information from the DLC C-plane uses the C channels, these are two independent channels, the C_S channel and the C_F channel.

The C_S channel is a slow duplex channel for higher layer information. It offers a low capacity which can be used by the higher layers with virtually no restriction. The transmission of C_S channel data reduces the throughput of the logical N channel.

The C_F channel is a fast duplex channel for higher layer information with a higher capacity than the C_S channel. Transmissions of C_F channel data may reduce the throughput of, or interrupt, the logical I channel.

All C channel information is protected by MAC layer error control which uses error correction based on an Automatic Repeat reQuest (ARQ).

5.3.1.2 The higher layer U-Plane channels, I

Higher layer information from the DLC U-plane uses the I channels. These are the I_N channel and the I_P channel, and they have different MAC layer protection schemes. The higher layers choose one of the two channels, the I_N and I_P channels shall not be used in parallel for the same connection.

The I_N information is protected by limited MAC layer error detection (X-field) and may include a minimum delay mode for coded speech transmission. Depending on the physical packet size the MAC layer processes I_N channel data in fields of different length.

The I_P information is protected by MAC layer procedures, either error correction based on a modulo 2 retransmission scheme or just error detection based on 16 bits or 32 bits CRCs or error correction with Turbo Code. Four B-field formats for I_P channel data are available:

- the Encoded protected format (MAC service I_{PX});
- the Multisubfield protected format (MAC services I_{PM} and I_{PMR});
- the Singlesubfield protected format (MAC services I_{PQ} and I_{PQR}); and
- the Constant-size subfield protected format (MAC services I_{PK} and I_{PKR}).

The DLC layer requests a service type, maximum allowed transmission time, and target and minimum acceptable numbers of uplink and downlink bearers which the MAC layer tries to provide.

The I_{PF} channel (see clause 5.3.1.4) can also be used for transporting U-plane information, in slots carrying at the same time channels G_F and M.

5.3.1.3 The higher layer U-Plane control channels, G_F and G_{FA}

Higher layer U-plane control from the DLC may use the G_F or G_{FA} channels.

The G_F channel is a fast simplex channel that is used to provide control of U-plane entities. For example, it is used to carry DLC acknowledgements (generally for asymmetric connections).

The G_{FA} channel is a slow simplex channel that is used to provide control of U-plane entities. It is used to carry DLC acknowledgements.

All G_F channel information is protected by a MAC layer error control which allows error detection.

G_F channel information is protected by B-field CRC.

G_{FA} channel information is protected by A-field CRC.

5.3.1.4 The higher layer U-Plane channel in E+U type slots, I_{PF}

The channel I_{PF} is used to carry U-plane information in slots where the B-field multiplexer is in E+U type mode (see clause 6.2.2). In E+U type, the B-field carries C-plane signalling (channels G_F and M) in some of the subfields and U-plane data in the other subfields. The number of subfields used for U-plane data and C-plane signalling varies depending on modulation, slot type, and amount of signalling to be transported. The possible combinations are defined in clause 6.2.2.3.1.

At least one subfield carrying C-plane signalling should exist. Subfields with U-plane data are always at the end of the slot.

I_{PF} channel could be used either if the regular I service is I_P or I_{PQ} , and either if the service is provided with error correction ($I_{P_error_correct}$) or error detection only ($I_{P_error_detect}$).

Due to the variable number of subfields allocated for U-plane data, and the different size of the U-plane bits per slot, compared to normal I_P or I_{PQ} size, a segmentation mechanism is required to split regular I_P or I_{PQ} packets for transporting by the I_{PF} channel. This mechanism uses the MAC message "Null or segmentation information" (see clause 7.3.3) and the NCF header of G_F channel message (see clause 7.3.6) in order to exchange segmentation information.

I_{PF} channel operation is described in clause 10.8.4.

I_{PF} channel is protected by MAC layer CRC (16 bits CRC for each subfield) and can be used with and without MAC ARQ.

5.3.2 CMC endpoints (MB-SAP logical channels)

5.3.2.1 The connectionless C-Plane channels, CL

Higher layer connectionless information from the DLC C-plane uses the CL channels, these are two independent channels, the CL_S channel and the CL_F channel.

The CL_S channel is a slow simplex channel for higher layer information. It offers a low capacity which can be used by the higher layers with virtually no restriction. The transmission of CL_S channel data reduces the throughput of the logical N channel.

The CL_F channel is a fast simplex channel for higher layer information with a higher capacity than the CL_S channel.

All CL channel information is protected by MAC layer error control which allows error detection.

5.3.2.2 The connectionless U-Plane channels, SI_N and SI_P

Higher layer connectionless information from the DLC U-plane uses the SI_N and SI_P channels.

The SI_N information is protected by limited MAC layer error detection (X-field) and can be used for coded speech transmission. Depending on the physical packet size the MAC layer processes SI_N channel data in fields of different length.

The SI_P information is protected by MAC layer error detection procedures based on 16 bit CRCs.

5.3.2.3 The connectionless U-Plane channel in E+U type slots, SI_{PF}

The equivalent of the I_{PF} channel for connectionless message control is the channel SI_{PF} . The SI_{PF} channel allows the transmission of reduced rate connectionless U-plane data multiplexed with connectionless MAC signalling broadcast.

SI_{PF} inherits all capabilities and procedures of I_{PF} , however with the following limitations:

- SI_{PF} can only operate in error_detection mode.
- There is no G_F channel in connectionless bearers.

A system can only support SI_{PF} channel if it also supports channel SI_P and channel I_{PF} .

5.3.3 BMC endpoint (MA-SAP logical channel)

5.3.3.1 The slow broadcast channel, B_S

The slow broadcast channel, B_S , is a simplex data channel in the direction FT to PTs. It is used to broadcast transient information from RFPs to all PTs that are listening. B_S channel data is transmitted by RFPs on traffic, connectionless, and dummy bearers. B_S channel information is available to Idle_Locked and Active_Locked PTs.

The transmission of B_S channel data reduces the throughput of the logical N channel.

All B_S channel information is protected by MAC layer error control which allows error detection.

NOTE: A typical use for the B_S channel is to broadcast call set-up requests; however, other uses are allowed.

5.3.3.2 The ULE broadcast channel, B_U

The ULE broadcast channel, B_U , is a simplex data channel in the direction FT to PTs. It is used to broadcast transient information from RFPs to all PTs that are listening to the ULE dummy bearer. B_U channel data is only transmitted by RFPs on ULE dummy bearers.

All B_U channel information is protected by MAC layer error control which allows error detection.

NOTE: A typical use for the B_U channel is to broadcast ULE set-up requests; however, other uses are allowed.

5.3.4 Internal MAC control channels

5.3.4.1 The system information channel, Q

The system information channel, Q, is a simplex data channel used to supply PTs with information about the DECT FP. Most Q channel data is transmitted as repeated broadcasts on traffic, connectionless and dummy bearers. Q channel data may also be transmitted on request.

Some Q channel information is needed by a PT to change from the Active_Unlocked state to the Idle_Locked state.

All Q channel information is protected by MAC layer error control which allows error detection.

5.3.4.2 Identities channel, N

The identities channel, N, is used for repeated transmissions of a system identity. N channel data is transmitted by RFPs on traffic, connectionless and dummy bearers, and by PTs on traffic bearers.

The identities channel N has two purposes:

- for Active_Unlocked PPs the N channel has a similar function as the Q channel. Here the N channel can be considered as a simplex channel in the RFP to PP direction. The broadcast identity helps active unlocked PPs to find a system which offers the desired service and to which they have access rights;
- for Active_Locked PPs the N channel is received on all FP to PP bearers and echoed on all PP to FP bearers to provide a MAC layer handshake.

All N channel information is protected by MAC layer error control which allows error detection.

5.3.4.3 The MAC control channel, M

The M channel is used to carry MAC layer information. This information appears in three different positions:

- MAC control in all header fields (see clause 6.2.1.2);
- MAC control in a tail field (see clause 6.2.2.1);
- MAC control in any B-subfield (see clause 6.2.2.3).

MAC control forms an integral part of all three services. When used on a duplex bearer (as part of the MBC service) it conveys point-to-point MAC control. On all services it is also used to broadcast MAC layer status information.

All M channel information is protected by MAC layer error control which allows error detection.

5.3.4.4 MAC paging channel, P

The P channel is used to carry paging messages. Each of these messages may contain one segment of data from the B_S logical channel.

The P channel appears as a part of all bearers transmitting in the direction FT to PT. The P channel is normally the only channel that is received by a PT in the Idle_Locked state.

All P channel information is protected by a MAC layer error control which allows error detection.

5.3.4.5 The Compound System Information Channel, Q_C

The extended system information channel, Q_C , is a simplex data channel used to supply PTs with information about the DECT FP. Q_C channel data is transmitted as repeated broadcasts on ULE dummy bearers. The Q_C channel and Q channel share some data.

The Q_C channel information is needed by a ULE PT to change from the Active_Unlocked state to the Idle_Locked state without having to collect multiple messages from the Q channel.

All Q_C channel information is protected by MAC layer error control which allows error detection.

5.3.4.6 The Split Identities Channel, N_S

The split identities channel, N_S , is a simplex data channel used to supply PTs with information about the identity of the DECT FP. N_S channel data is transmitted as repeated broadcasts on ULE dummy bearers. The N_S channel and the N_t channel share some data.

The N_S channel information is used by a ULE PT to check the identity of the RFP to ensure that this is a system to which it has access rights.

All N_S channel information is protected by MAC layer error control which allows error detection.

5.3.4.7 The ULE MAC Control Channel, M_U

The reduced MAC control channel, M_U channel is used to carry ULE MAC layer information. M_U channel data is transmitted as repeated broadcasts on ULE dummy bearer. The M_U channel information is specific to this channel.

The M_U channel information is used by a ULE PT when attempting to set up a connection to the FP.

All M_U channel information is protected by MAC layer error control which allows error detection.

5.3.4.8 The ULE Paging Channel, P_U

The ULE control channel, P_U , is used to carry paging messages and broadcast messages from the RFP to the PTs. The P_U channel is transmitted as repeated messages on ULE dummy bearers. The P_U channel information is specific to this channel. The P_U channel is used to send data from the B_U logical channel.

All P_U channel information is protected by a MAC layer error control which allows error detection.

5.4 SAP definitions

The MAC layer communicates with the DLC layer through 3 SAPs. These SAPs are the MA SAP, the MB SAP and the MC SAP.

The MAC layer communicates with the management entity through the ME SAP.

The MAC layer communicates with each PHL instance through an independent D SAP. The D SAP is defined in EN 300 175-2 [2].

5.4.1 MA SAP

This is a SAP between the MAC and DLC layers. The SAP contains a single broadcast endpoint, containing one logical channel, the B_S channel. The primitives passed through the MA SAP are used to:

- carry B_S channel data; and
- control the data flow of the B_S channel data.

The B_S channel provides a connectionless simplex (broadcast) service in the direction FT to PT.

The permitted SDU lengths in primitives carrying B_S channel data are 0 bit, 20 bits, 36 bits, 72 bits, 108 bits, 144 bits, 180 bits or 216 bits.

5.4.2 MB SAP

This is a SAP between the MAC and the DLC layer. The MB SAP contains one service endpoint with four logical channels, the CL_F , CL_S , SI_N and SI_P channels.

The CL_S and CL_F channels provide connectionless services in both directions, FT to PT and PT to FT. In direction FT to PTs the connectionless service is continuous, in direction PT to FT the service is discontinuous.

The permitted SDU length in primitives containing CL_S channel data is 40 bits (= 1 CL_S segment).

The permitted SDU length in primitives containing CL_F channel data is an integer multiple of the CL_F data segment length, which is 64 bits.

The SI_N channel offers one unprotected simplex service to the higher layers (FT to PT only).

The SI_P channel offers one protected simplex service to the higher layers (FT to PT only).

For the SI_N service the SDU length corresponds to the size of the SI_N data fields in the U-type multiplexes (see clause 6.2.2.2).

For the SI_P service, the SDU length corresponds to the size of the SI_P data fields in the U-type multiplexes (see clause 6.2.2.2).

5.4.3 MC SAP

This is a SAP between the MAC and DLC layers. The SAP may contain multiple connection endpoints, and six logical channels are associated with each endpoint; C_S , C_F , G_F , G_{FA} , I_N and I_P channels. Primitives transferred through this SAP are used to:

- control the MAC processes to establish, maintain and release connections;
- carry C_S , C_F , G_F , G_{FA} , I_N and I_P channel data; and
- control the data flow of the C_S , C_F , G_F , G_{FA} , I_N and I_P channel data.

The C_S and the C_F channel offer two independent connection-oriented duplex services.

For one connection the maximum throughput of C_S channel data is 2 kbit/s. The SDU length of primitives carrying C_S channel data is equal to the C_S data segment length of 40 bits.

The maximum throughput of C_F channel data is 6,4 kbit/s for half slot connections, 25,6 kbit/s for full slot connections, 51,2 kbit/s for long slot ($j=640/672$) connections and 64 kbit/s for double slot connections. For C_F channel data the SDU length is an integer multiple of the C_F data segment length, which is 64 bits.

NOTE: DECT capacity on the air interface, when indicated in bits, often reflects the DECT 2-level modulation option. The I_P and I_N channels offer two independent connection orientated duplex services to the higher layers. One service uses either the logical I_N or the logical I_P channel.

For all data services the SDU length is an integer multiple of the I channel data segment length. The segment length need not be the same for every service and corresponds to the size of the I_N and I_P data fields in the U-type multiplexes (see clause 6.2.2.2).

The G_F channel offers a connection oriented simplex service. The G_F SDU length is 56 bits.

The G_{FA} channel offers a simplex service. The G_{FA} SDU length is 10 or 8 bits, depending on the carrying message.

5.4.4 ME SAP

This is a SAP between the MAC layer and the management entity. There is no formal definition for this interface, i.e. no endpoints and no logical channels are defined.

The following information is transferred:

- control of certain MAC processes (e.g. encryption);
- transfer of certain broadcast data (e.g. FP identities);
- carry B_U channel data; and
- control the data flow of the B_U channel data.

5.4.5 Order of transmission

Certain primitives exchanged between the MAC layer and the DLC layer may have a SDU containing peer-to-peer messages. The SDU data is arranged as a list of octets or part octets, starting with octet 1. The bits within one octet are numbered from 1 to 8 where the most significant bit has number 8. The MAC layer transmits these octets in ascending order, starting with octet 1. Valid bits within one octet are transmitted in descending order.

5.5 Bearers

MAC bearers are the elements that are created by each cell site function. Each bearer corresponds to a single service instance to one PHL. Duplex and double-simplex bearers may be combined by the MBC to provide complete MAC connections to provide a co-ordinated connection oriented service (see clause 5.6).

5.5.1 Bearer types

Four types of bearer are defined:

- 1) **Simplex bearer:** a simplex bearer is created by allocating one physical channel for transmissions in one direction. Two types of simplex bearers exist, short and long simplex bearers. The short simplex bearers only contain the A-field whereas long simplex bearers contain the A-field and the B-field (see clause 6.2.1). One simplex bearer is created by one dummy bearer controller or by one connectionless bearer controller. A DBC shall always control a short simplex bearer.
- 2) **Duplex bearer:** a duplex bearer is created by a pair of simplex bearers, operating in opposite directions on two physical channels. These pairs of channels shall always use the same RF carrier and shall always use evenly spaced time slots (i.e. the starting points of the time slots are separated by 0,5 frame). One duplex bearer is created by one traffic bearer controller or one connectionless bearer controller. A duplex bearer controlled by a TBC always contains the A-field and the B-field in both directions (see clause 6.2.1).

- 3) **Double simplex:** a double simplex bearer is created by a pair of long simplex bearers operating in the same direction on two physical channels. These pairs of channels shall always use the same RF carrier and shall always use evenly spaced time slots (i.e. the starting points of the time slots are separated by 0,5 frame). Double simplex bearers shall only exist as part of a multi-bearer connection. One double simplex bearer is created by one traffic bearer controller.
- 4) **Double duplex bearer:** a double duplex bearer is composed by a pair of duplex bearers referring to the same MAC connection. Each duplex bearer is created by one TBC and the pair is controlled by the same MBC. The duplex bearers share their simplex bearers for the information flow.

Transmission on a bearer uses the PL_TX primitive, where the SDU in each PL_TX-req primitive contains the data for one slot (for one transmission).

Reception on a bearer uses the PL_RX primitive, where the SDU in each PL_RX-cfm primitive contains the data for one slot (for one reception).

5.5.2 Bearer operation

A bearer can exist in one of three operational states:

- 1) **Dummy bearer:** where there are normally continuous transmissions (i.e. one transmission in every frame, refer to clause 5.7). These transmissions never contain data related to the MC or the MB SAP. A dummy bearer only supports BMC services. A dummy bearer is a short simplex bearer.
- 2) **Traffic bearer:** where there are continuous point-to-point transmissions that usually contain MC SAP data but never contain data related to the MB SAP. A traffic bearer supports both, BMC and MBC services. A traffic bearer is a duplex bearer or a double simplex bearer or a double duplex bearer.
- 3) **Connectionless bearer:** where there are transmissions that may contain MB SAP data but never contain data related to the MC SAP. A connectionless bearer supports both BMC and CMC services. In the direction FT to PTs a connectionless bearer is either duplex if the RFP also supports the connectionless uplink service, or simplex if it does not support the connectionless uplink service. For a PT, a connectionless bearer is either a simplex or a duplex bearer.

"Logical bearer" defines the effective service available from one traffic bearer. During bearer handover two identical duplex or double simplex bearers may exist to provide the service of one logical bearer. At all other times each logical bearer corresponds to one duplex or double simplex bearer.

5.6 Connection oriented services

Each MBC instance creates one MAC connection, and provides an independent service to the higher (DLC) layer. A MAC connection is wholly contained within one cluster, using the services of one or more TBCs within that cluster.

Each MAC connection may use the services of one or more bearers. A single-bearer connection shall use a single duplex bearer. A multi-bearer connection shall use one duplex bearer plus one or more additional duplex and/or double simplex bearers.

5.6.1 Connection types

The MAC provides C channel and I channel services to the DLC layer by setting up and maintaining MAC connections.

All RFPs of a cluster shall provide the same capabilities to transmit higher layer control (in particular, the C_F and G_F channel capabilities shall be the same).

Three type of connections are defined:

- basic connections;
- advanced connections;
- complementary connections.

5.6.1.1 Basic connections

Basic connections have no common connection number (common is defined to mean the same connection number is known at both PT and FT). Therefore, only one basic connection may exist between a PT (identified by its PMID) and one particular FT (identified by the ARI).

Exception: During connection handover two basic connections may exist, serving the same DLC link.

Basic connections only provide one full slot duplex bearer for the $I_{N_minimum_delay}$ service. Suspension from B-field transmission can be allowed (i.e. the use of short bearers) in the direction PT to FT, once the bearer has been established. The use of a short bearer shall be signalled by the no B-field BA bits code (see clause 7.1.4); in this case, if the connection is ciphered, the two key stream segments of the D.32 field still apply of which only the first 40 bits are used (see EN 300 175-7 [7], clause 6.4.2).

Because basic connections are always single bearer connections no Logical Bearer Number (LBN) is assigned to the bearer for these connections.

Basic connections shall not support C_F , G_F and I_P channels and shall not send MAC extended control in the B-field.

NOTE: It is allowed to have a basic connection plus additional advanced connections with ECN different from zero between the same PT-FT pair. However basic connections are not compatible with advanced connections with ECN=0. If there is an already established advanced connection with ECN=0 it is not possible to set up a basic connection between the same PT-FT pair. However, there is the possibility of changing first the ECN number of the advanced connection using the procedure described in clause 10.3.2.3.

5.6.1.2 Advanced connections

Advanced connections have a common connection number, called Exchanged Connection Number (ECN) which is assigned by the LLME. Therefore, more than one advanced connection may exist between a PT and one FT. Advanced connections may provide any service listed in clauses 5.6.2.1 and 5.6.2.2.

Advanced connections may use any ECN value from 0 to 15, however the value ECN=0 can only be used if:

- 1) there is no a basic connection between the same PT-FT pair; and
- 2) the connection attributes are different of: full slot, MAC service $I_{N_minimum_delay}$ and no C_F .

If ECN=0 is chosen, then the connection will automatically switch to basic when the attributes are set to full slot, MAC service $I_{N_minimum_delay}$ and no C_F (see clause 10.3.3.2).

Bearers of advanced connections are labelled by the MAC with LBNs (common parameters). The LBN enables the MAC to distinguish between different bearers in the same connection.

Advanced connections may support the C_F channel.

5.6.1.2.1 Rules for ECN selection in advanced connections

The Advanced connection initiating side may choose any unused value of ECN with the following rules:

- a) If there is not an already established basic connection or advanced connection with ECN=0 between the PT-FT pair, THEN the initiating should select ECN=0 for an advanced connection only IF:
 - 1) the connection is not fullslot, $I_{N_minimum_delay}$, no C_F ; and
 - 2) the desired behaviour is that the connection is automatically turned to basic if attributes are set to fullslot, $I_{N_minimum_delay}$, no C_F .

Otherwise, the PT should select any other value (different from 0) for the ECN.

- b) If there is already an advanced connection with ECN = 0, OR a basic connection between the PT-FT pair, THEN the ECN for a new advanced connection shall be different from zero (ECN > 0).

5.6.1.2.2 Expedited operations in advanced connections

A set of messages from the advanced connection control part 2 (see clause 7.2.5.12) are intended for optimized handling of packet mode connections with maximum efficiency and minimum energy consumption. The procedures describing the operations with such expedited messages are described in clauses 10.5.1.8 and 10.7.3. Expedited operations are optimized for low power consumption and are used by DECT ULE (see TS 102 939-1 [i.10]).

Only one instance of advanced connection may use expedited procedures. Such instance is identified by a given value of the ECN number.

NOTE: The recommended ECN number for expedited connections is ECN=7 and this is the value used in TS 102 939-1 [i.10].

If a system supports services using expedited and other advanced (non-expedited) connections, the ECN value reserved for the expedited procedures (typically ECN = 7) should not be used by the regular advanced connections.

5.6.1.3 Connection identifiers

Locally each connection (each instance of an MBC) is always identified by a MAC Connection Endpoint Identification (MCEI). This MCEI allows the DLC to select one particular connection. In the PT the MCEI is assigned by the LLME and is unique within that PT. In the FT the MCEI is assigned by the LLME and is unique within that FT identified by its ARI. In general the MCEIs will be different in the PT and the FT for any given connection.

For advanced connections, a further common identifier, the ECN, is transmitted between PT and FT. The full identifier consists of ARI + PMID + ECN. PMID and ARI identify the PT and the FT. The ECN allows different advanced connections between the same PT and FT to be distinguished. The DLC and MAC at both ends know this common identifier.

5.6.1.4 Complementary connections

Complementary connections only provide one duplex bearer without referring to a particular service.

Complementary connections do not require the opening of a DLC link and can be identified at the MAC layer by the PMID.

A duplex bearer of a complementary connection can be linked to a duplex bearer of a basic or an advanced connection by a mapping procedure (see clause 10.5.1.6); after the mapping, it shall acquire the same properties of the linked channel and shall be referred to the same connection. The two linked bearers constitute a double duplex bearer.

5.6.2 Symmetric and asymmetric connections

The different connection oriented service types are divided into two categories, symmetric and asymmetric connections:

- **Symmetric connections** will always have the same number of simplex bearers in both transmission directions. Moreover the service characteristics (see clause 5.6.2.1) and their bandwidths are the same for both directions.
- **Asymmetric connections** have a different number of logical simplex bearers for both transmission directions. Typically, there are only one or two bearers in the "reverse" direction. Although the services in both directions have the same characteristics the bandwidth of the services will differ.
- **Multibearer connections** exist only in full slot, long slot ($j=640$ and $j=672$) and double slot transmission mode. This means that multibearer asymmetric and symmetric connections are not permitted in half slot transmission mode. All bearers of a multibearer connection shall be from the same slot type, i.e. either full slot, long slot or double slot.

In all connections, the DLC gives the MAC a "target number of bearers" and a "minimum acceptable number of bearers" to establish. When the connection has been established (or set-up has failed), the MAC tells the DLC the "actual number of bearers" that have been established. In many cases the "target number of bearers" equals the "minimum acceptable number of bearers".

5.6.2.1 Symmetric connections

A DECT symmetric connection has the same number of bearers in both directions and is composed of duplex bearers only.

The five symmetric service types are distinguished by their I channel data protection and their throughput:

- type 1: $I_{N_minimum_delay}$ (I_{NA}): limited error protection, minimum delay, fixed throughput;
- type 2: $I_{N_normal_delay}$ (I_{NB}): limited error protection, half-frame synchronization, fixed delay, fixed throughput;
- type 3: $I_{P_error_detection}$: error detection capability, minimum delay, fixed throughput; The type 3, $I_{P_error_detection}$ service may be:
 - type 3a: (I_{PM}); $I_{P_error_detection}$ using multi-subfield protected B-field format (as clause 6.2.1.3.3);
 - type 3b: (I_{PQ}); $I_{P_error_detection}$ using single subfield protected B-field format (as clause 6.2.1.3.4);
 - type 3c: (I_{PK}); $I_{P_error_detection}$ using constant-size subfield protected B-field format (as clause 6.2.1.3.5);
- type 4: $I_{P_error_correction}$: error correction, variable throughput; The type 4, $I_{P_error_correction}$ service may be:
 - type 4a: (I_{PMR}); $I_{P_error_correction}$ using multi-subfield protected B-field format (as clause 6.2.1.3.3);
 - type 4b: (I_{PQR}); $I_{P_error_correction}$ using single subfield protected B-field format (as clause 6.2.1.3.4);
 - type 4c: (I_{PKR}); $I_{P_error_correction}$ using constant-size subfield protected B-field format (as clause 6.2.1.3.5);
- type 5: $I_{P_encoded_protected}$ (I_{PX}).

NOTE 1: $I_{N_minimum_delay}$ (I_{NA}) and $I_{N_normal_delay}$ (I_{NB}) services have different I channel flow control (see clauses 10.3 and 8.4).

NOTE 2: The throughput of service types 2 and 3 can vary if the MAC layer changes the number of bearers assigned to that connection.

NOTE 3: The bearers of a symmetric connection are normally in U-type multiplexer mode. However, from time to time, they can be switched to E or E+U type mode to exchange signalling messages (channels M, G_F or C_F). During the time the bearer is in E or E+U type mode it cannot carry I_N , I_P , I_{PQ} channel data. However, if they are in E+U type mode, they can carry I_{PF} channel data.

The most important parameters of the five symmetric services are listed in tables 5.1, 5.2 and 5.3.

Table 5.1: Symmetric services (2-level modulation)

ST	I channel capacity (kbit/s)	B-field multiplex schemes	NP	Err det.	Error correction		Max. C _F (kbit/s)	Delay (ms)		
					ARQ	Channel coding		DECT transm. time (note 4)	Practical delay for applications:	
									voice (note 5)	data (note 6)
1d2	k x 80	(U80a,E80)	I _{NA}	No	No	No	64,0	0,781	≈ 10	≈ 5,781
1l2 (j=640)	k x 64	(U64a,E64)	I _{NA}	No	No	No	51,2	0,642	≈ 10	≈ 5,642
1l2 (j=672)	k x 67,2	(U67a,E67)	I _{NA}	No	No	No	51,2	0,670	≈ 10	≈ 5,670
1f2	k x 32	(U32a,E32)	I _{NA}	No	No	No	25,6	0,365	≈ 10	≈ 5,365
1h2	8 + j/10	(U08a,E08)	I _{NA}	No	No	No	6,4	0,156	≈ 10	≈ 5,156
2d2	k x 80	(U80a,E80)	I _{NB}	No	No	No	64,0	5	15	10
2l2 (j=640)	k x 64	(U64a,E64)	I _{NB}	No	No	No	51,2	5	15	10
2l2 (j=672)	k x 67,2	(U67a,E67)	I _{NB}	No	No	No	51,2	5	15	10
2f2	k x 32	(U32a,E32)	I _{NB}	No	No	No	25,6	5	15	10
2h2	8 + j/10	(U08a,E08)	I _{NB}	No	No	No	6,4	5	15	10
3d2	k x 64,0	(U80b,E80)	I _{PM}	Yes	No	No	64,0	0,781	≈ 10	≈ 5,781
3l2 (j=640)	k x 51,2	(U64b,E64)	I _{PM}	Yes	No	No	51,2	0,642	≈ 10	≈ 5,642
3l2 (j=672)	k x 51,2	(U67b,E67)	I _{PM}	Yes	No	No	51,2	0,670	≈ 10	≈ 5,670
3f2	k x 25,6	(U32b,E32)	I _{PM}	Yes	No	No	25,6	0,365	≈ 10	≈ 5,365
3h2	6,4	(U08b,E08)	I _{PM}	Yes	No	No	6,4	0,156	≈ 10	≈ 5,156
4d2	≤ k x 64,0	(U80b,E80)	I _{PMR}	Yes	Yes	No	64,0	Variable (see note 8)		
4l2 (j=640)	≤ k x 51,2	(U64b,E64)	I _{PMR}	Yes	Yes	No	51,2	Variable (see note 8)		
4l2 (j=672)	≤ k x 51,2	(U67b,E67)	I _{PMR}	Yes	Yes	No	51,2	Variable (see note 8)		
4f2	≤ k x 25,6	(U32b,E32)	I _{PMR}	Yes	Yes	No	25,6	Variable (see note 8)		
4h2	≤ 6,4	(U08b,E08)	I _{PMR}	Yes	Yes	No	6,4	Variable (see note 8)		
3d2ssub	k x 76,8	U80c	I _{PQ}	Yes	No	No	64,0	0,781	≈ 10	≈ 5,781
3l2ssub (j=640)	k x 60,8	U64c	I _{PQ}	Yes	No	No	51,2	0,642	≈ 10	≈ 5,642
3l2ssub (j=672)	k x 64,0	U67c	I _{PQ}	Yes	No	No	51,2	0,670	≈ 10	≈ 5,670
3f2ssub	k x 30,4	U32c	I _{PQ}	Yes	No	No	25,6	0,365	≈ 10	≈ 5,365
4d2ssub	≤ k x 76,8	U80c	I _{PQR}	Yes	Yes	No	64,0	Variable (see note 8)		
4l2ssub (j=640)	k x 60,8	U64c	I _{PQR}	Yes	Yes	No	51,2	Variable (see note 8)		
4l2ssub (j=672)	k x 64,0	U67c	I _{PQR}	Yes	Yes	No	51,2	Variable (see note 8)		
4f2ssub	≤ k x 30,4	U32c	I _{PQR}	Yes	Yes	No	25,6	Variable (see note 8)		
3d2csub	k x 76,8	U80d	I _{PK}	Yes	No	No	64,0	0,781	≈ 10	≈ 5,781
3l2csub (j=640)	k x 60,8	U64d	I _{PK}	Yes	No	No	51,2	0,642	≈ 10	≈ 5,642
3l2csub (j=672)	k x 64,0	U67d	I _{PK}	Yes	No	No	51,2	0,670	≈ 10	≈ 5,670
3f2csub	k x 30,4	U32d	I _{PK}	Yes	No	No	25,6	0,365	≈ 10	≈ 5,365
4d2csub	≤ k x 76,8	U80d	I _{PKR}	Yes	Yes	No	64,0	Variable (see note 8)		
4l2csub (j=640)	k x 60,8	U64d	I _{PKR}	Yes	Yes	No	51,2	Variable (see note 8)		
4l2csub (j=672)	k x 64,0	U67d	I _{PKR}	Yes	Yes	No	51,2	Variable (see note 8)		
4f2csub	≤ k x 30,4	U32d	I _{PKR}	Yes	Yes	No	25,6	Variable (see note 8)		

ST	I channel capacity (kbit/s)	B-field multiplex schemes	NP	Err det.	Error correction		Max. C_F (kbit/s)	Delay (ms)		
					ARQ	Channel coding		DECT transm. time (note 4)	Practical delay for applications:	
									voice (note 5)	data (note 6)
5d2encoded	$k \times (80,0) \times r$	(U80e, E80)	I_{PX}	lim	No	Yes	64,0	0,781	≈ 10	$\approx 5,781$
5l2encoded (j=640)	$k \times (64,0) \times r$	(U64e, E64)	I_{PX}	lim	No	Yes	51,2	0,642	≈ 10	$\approx 5,642$
5f2encoded	$k \times (32,0) \times r$	(U32e, E32)	I_{PX}	lim	No	Yes	25,6	0,365	≈ 10	$\approx 5,365$
5h2encoded	$k \times (8,0) \times r$	(U08e, E08)	I_{PX}	lim	No	Yes	6,4	0,156	≈ 10	$\approx 5,156$

ST: Service Type:
x dy = type x double slot, modulation y levels;
x ly = type x long slot (j=640 or j=672), modulation y levels;
x fy = type x full slot, modulation y levels;
x hy = type x half slot, modulation y levels;
ssub = single subfield protected B-field format.
csub = constant-size subfield protected B-field format.
encoded: Encoded protected B-field format; The I channel capacity varies in function of the adaptive code rate r.
NP: Name of the U-plane channel.
err. det.: error detection capability.
err. corr.: error correction capability (ARQ or channel coding).
max. C_F : maximum C_F channel throughput.
delay: approximate delay incurred by I channel data in ms.
k: the actual number of duplex bearers; $w \leq k \leq t$.
lim: limited capacity. See note 9 below the table.

NOTE: Refer to clause 6.2.2.2 for details of B-field multiplex schemes. All references to notes refers to notes in this clause.

NOTE 4: This is the transmission delay of the DECT MAC layer. In I_{N_normal} delay service (I_{NB}), it is synchronized with DECT half frame (5 ms). For other services it is equal to the slot time.

NOTE 5: Practical overall delay for voice applications (single bearer). It applies also for the transmission of a continuous stream of unstructured data (single bearer) when the DECT system may decide how to packet the data in the bearers (packet boundaries). The delay consist on 10 ms (1 DECT frame) = basic packetization delay plus transmission delay (or not, if the packetization continues during the transmission time). In minimum delay services, there would be loss of data or duplication if the slot position changes (due to a handover).

NOTE 6: Practical transmission delay for packet data applications. It is the time that the DECT system requires for transmission of a data packet provided by a higher layer or by an external system, from one side to another. The delay consist of 5 ms = average delay due to the time difference between packet arrival and DECT slot, plus DECT MAC transmission delay. Note that it does not include the packetization delay (that has been done by other layers) and that it is an average value (in the worst case of packet arrival / slot position, delay may be 5 ms longer).

NOTE 7: In multibearer connections, the delay may be reduced compared to the figures indicated. Reduction depends on service, number of slots and slot positions in use.

NOTE 8: The delay for $I_{p_error_correct}$ services is variable and equal to the $I_{p_error_detect}$ service ($\approx 5,365$ ms to $\approx 5,781$ ms) if there is no retransmission of the packet. If there are retransmissions, the delay increases by 10 additional ms for each retransmission (up to the limit defined by MAC lifetime).

NOTE 9: The error detection capability for the $I_{p_encoded}$ protected (I_{pX}) service is limited. There is no error detection capability when r parameter is equal to 1.

NOTE 10: The error correction capability for the $I_{p_encoded}$ protected service (I_{pX}) depends on r rate. There is no error correction capability when r parameter is equal to 1.

Table 5.2: Symmetric services (4-level and 8-level modulation)

ST	I channel capacity (kbit/s)	B-field multiplex schemes	NP	Err det.	Err corr. ARQ	Err corr. coding	max. C _F (kbit/s)	dly (ms)
1d4	160	(U160a, E160)	I _{NA}	No	No	No	128,0	≈10
1d8	240	(U240a, E240)	I _{NA}	No	No	No	192,0	≈10
1l4 (j=640)	128	(U128a, E128)	I _{NA}	No	No	No	102,4	≈10
1l8 (j=640)	192	(U192a, E192)	I _{NA}	No	No	No	153,6	≈10
1f4	64	(U64a, E64)	I _{NA}	No	No	No	51,2	≈10
1f8	96	(U96a, E96)	I _{NA}	No	No	No	76,8	≈10
1h4	16 + j/10	(U16a, E16)	I _{NA}	No	No	No	12,8	≈10
1h8	24 + j/10	(U24a, E24)	I _{NA}	No	No	No	19,2	≈10
2d4	k x 160	(U160a, E160)	I _{NB}	No	No	No	128,0	15
2d8	k x 240	(U240a, E240)	I _{NB}	No	No	No	192,0	15
2l4 (j=640)	k x 128	(U128a, E128)	I _{NB}	No	No	No	102,4	15
2l8 (j=640)	k x 192	(U192a, E192)	I _{NB}	No	No	No	153,6	15
2l4 (j=672)	k x 134,4	(U134a, E134)	I _{NB}	No	No	No	102,4	15
2l8 (j=672)	k x 201,6	(U201a, E201)	I _{NB}	No	No	No	153,6	15
2f4	k x 64	(U64a, E64)	I _{NB}	No	No	No	51,2	15
2f8	k x 96	(U96a, E96)	I _{NB}	No	No	No	76,8	15
2h4	16 + j/10	(U16a, E16)	I _{NB}	No	No	No	12,8	15
2h8	24 + j/10	(U24a, E24)	I _{NB}	No	No	No	19,2	15
3d4	k x 128	(U160b, E160)	I _{PM}	Yes	No	No	128,0	15
3d8	k x 192	(U240b, E240)	I _{PM}	Yes	No	No	192,0	15
3l4 (j=640)	k x 102,4	(U128b, E128)	I _{PM}	Yes	No	No	102,4	15
3l8 (j=640)	k x 153,6	(U192b, E192)	I _{PM}	Yes	No	No	153,6	15
3l4 (j=672)	k x 102,4	(U134b, E134)	I _{PM}	Yes	No	No	102,4	15
3l8 (j=672)	k x 153,6	(U201b, E201)	I _{PM}	Yes	No	No	153,6	15
3f4	k x 51,2	(U64b, E64)	I _{PM}	Yes	No	No	51,2	15
3f8	k x 76,8	(U96b, E96)	I _{PM}	Yes	No	No	76,8	15
3h4	12,8	(U16b, E16)	I _{PM}	Yes	No	No	12,8	15
3h8	19,2	(U24b, E24)	I _{PM}	Yes	No	No	19,2	15
4d4	≤ k x 128	(U160b, E160)	I _{PMR}	Yes	Yes	No	128,0	var
4d8	≤ k x 192	(U240b, E240)	I _{PMR}	Yes	Yes	No	192,0	var
4l4 (j=640)	≤ k x 102,4	(U128b, E128)	I _{PMR}	Yes	Yes	No	102,4	var
4l8 (j=640)	≤ k x 153,6	(U192b, E192)	I _{PMR}	Yes	Yes	No	153,6	var
4l4 (j=672)	≤ k x 102,4	(U134b, E134)	I _{PMR}	Yes	Yes	No	102,4	var
4l8 (j=672)	≤ k x 153,6	(U201b, E201)	I _{PMR}	Yes	Yes	No	153,6	var
4f4	≤ k x 51,2	(U64b, E64)	I _{PMR}	Yes	Yes	No	51,2	var
4f8	≤ k x 76,8	(U96b, E96)	I _{PMR}	Yes	Yes	No	76,8	var
4h4	≤ 12,8	(U16b, E16)	I _{PMR}	Yes	Yes	No	12,8	var
4h8	≤ 19,2	(U24b, E24)	I _{PMR}	Yes	Yes	No	19,2	var
3d4ssub	k x 156,8	U160c	I _{PQ}	Yes	No	No	-	15
3d8ssub	k x 236,8	U240c	I _{PQ}	Yes	No	No	-	15
3l4ssub (j=640)	k x 124,8	U128c	I _{PQ}	Yes	No	No	-	15
3l8ssub (j=640)	k x 188,8	U192c	I _{PQ}	Yes	No	No	-	15
3l4ssub (j=672)	k x 131,2	U134c	I _{PQ}	Yes	No	No	-	15
3l8ssub (j=672)	k x 198,4	U201c	I _{PQ}	Yes	No	No	-	15
3f4ssub	k x 60,8	U64c	I _{PQ}	Yes	No	No	-	15
3f8ssub	k x 92,8	U96c	I _{PQ}	Yes	No	No	-	15
4d4ssub	≤ k x 156,8	U160c	I _{PQR}	Yes	Yes	No	-	var
4d8ssub	≤ k x 236,8	U240c	I _{PQR}	Yes	Yes	No	-	var
3l4ssub (j=640)	≤ k x 124,8	U128c	I _{PQR}	Yes	Yes	No	-	var
3l8ssub (j=640)	≤ k x 188,8	U192c	I _{PQR}	Yes	Yes	No	-	var

ST	I channel capacity (kbit/s)	B-field multiplex schemes	NP	Err det.	Err corr. ARQ	Err corr. coding	max. C _F (kbit/s)	dly (ms)
3l4ssub (j=672)	≤ k x 131,2	U134c	I _{PQR}	Yes	Yes	No	-	var
3l8ssub (j=672)	≤ k x 198,4	U201c	I _{PQR}	Yes	Yes	No	-	var
4f4ssub	≤ k x 60,8	U64c	I _{PQR}	Yes	Yes	No	-	var
4f8ssub	≤ k x 92,8	U96c	I _{PQR}	Yes	Yes	No	-	var
3d4csub	k x 153,6	U160d	I _{PK}	Yes	No	No	-	15
3d8csub	k x 230,4	U240d	I _{PK}	Yes	No	No	-	15
3l4csub (j=640)	k x 121,6	U128d	I _{PK}	Yes	No	No	-	15
3l8csub (j=640)	k x 182,4	U192d	I _{PK}	Yes	No	No	-	15
3l4csub (j=672)	k x 128,0	U134d	I _{PK}	Yes	No	No	-	15
3l8csub (j=672)	k x 192,0	U201d	I _{PK}	Yes	No	No	-	15
3f4csub	k x 60,8	U64d	I _{PK}	Yes	No	No	-	15
3f8csub	k x 91,2	U96d	I _{PK}	Yes	No	No	-	15
4d4csub	≤ k x 153,6	U160d	I _{PKR}	Yes	Yes	No	-	var
4d8csub	≤ k x 230,4	U240d	I _{PKR}	Yes	Yes	No	-	var
3l4csub (j=640)	≤ k x 121,6	U128d	I _{PKR}	Yes	Yes	No	-	var
3l8csub (j=640)	≤ k x 182,4	U192d	I _{PKR}	Yes	Yes	No	-	var
3l4csub (j=672)	≤ k x 128,0	U134d	I _{PKR}	Yes	Yes	No	-	var
3l8csub (j=672)	≤ k x 192,0	U201d	I _{PKR}	Yes	Yes	No	-	var
4f4csub	≤ k x 60,8	U64d	I _{PKR}	Yes	Yes	No	-	var
4f8csub	≤ k x 91,2	U96d	I _{PKR}	Yes	Yes	No	-	var
5d4encoded	k x (80,0/96,0/120,0/ 128,0/160,0)	(U160e, E160)	I _{PX}	lim	No	Yes	128,0	15
5d8encoded	k x (120,0/144,0/ 180,0/192,0)	(U240e, E240)	I _{PX}	lim	No	Yes	192,0	15
5l4encoded (j=640)	k x (64,0/76,8/96,0/ 102,4/128,0)	(U128e, E128)	I _{PX}	lim	No	Yes	102,4	15
5l8encoded (j=640)	k x (96,0/115,2/ 144,0/153,6)	(U192e, E192)	I _{PX}	lim	No	Yes	153,6	15
5f4encoded	k x (32,0/38,4/48,0/ 51,2/64,0)	(U64e, E64)	I _{PX}	lim	No	Yes	51,2	15
5f8encoded	k x (48,0/57,6/ 72,0/76,8)	(U96e, E96)	I _{PX}	lim	No	Yes	76,8	15
5h4encoded	k x (8,0/9,6/12,0/ 12,8/16,0)	(U16e, E16)	I _{PX}	lim	No	Yes	12,8	15
5h8encoded	k x (12,0/14,4/ 18,0/19,2)	(U24e, E24)	I _{PX}	lim	No	Yes	19,2	15

ST: Service Type:
 xdy = type x double slot, modulation y levels;
 xly = type x long slot (j=640 or j=672), modulation y levels;
 xfy = type x full slot, modulation y levels;
 xhy = type x half slot, modulation y levels;
 f = 0 for 2-level modulation in A field;
 f = 64 for 4-level modulation in A field;
 f = 128 for 8-level modulation in A field;
 ssub = single subfield protected B-field format.
 csup = constant-size subfield protected B-field format.
 encoded: Encoded protected B-field format; the I channel capacity varies in function of the adaptive code rate r.
 NP: I_N channel or I_P channel.
 Err. det.: error detection capability.
 Err. corr.: error correction capability (based on channel coding for I_{PX} (see note 10), ARQ for all others).
 max. C_F: maximum C_F channel throughput.
 dly: approximate delay incurred by I channel data in ms. "var" is variable.
 t: the target number of duplex bearers; w ≤ t.
 k: the actual number of duplex bearers; w ≤ k ≤ t.
 lim: limited capacity. See note 9 in this clause.

NOTE: Refer to clause 6.2.2.2 for details of B-field multiplex schemes.

Table 5.3: Symmetric services (16-level and 64-level modulation)

ST	I channel capacity (kbit/s)	B-field multiplex schemes	NP	Err det.	Err corr.	max. C_F (kbit/s)	dly (ms)
5d16encoded	k x (128,0/160,0/ 192,0/240,0/ 256,0)	(U320e, E320)	I_{PX}	lim	Yes, code	256,0	15
5d64encoded	k x (160,0/192,0/ 240,0/288,0/ 360,0/384,0)	(U480e, E480)	I_{PX}	lim	Yes, code	384,0	15
5l16encoded (j=640)	k x (102,4/128,0/ 153,6/192,0/ 204,8)	(U256e, E256)	I_{PX}	lim	Yes, code	204,8	15
5l64encoded (j=640)	k x (128,0/153,6/ 192,0/230,4/ 288,0/307,2)	(U384e, E384)	I_{PX}	lim	Yes, code	307,2	15
5f16encoded	k x (51,2/64,0/ 76,8/96,0/102,4)	(U128e, E128)	I_{PX}	lim	Yes, code	102,4	15
5f64encoded	k x (64,0/76,8/96,0/ 115,2/144,0/ 153,6)	(U192e, E192)	I_{PX}	lim	Yes, code	153,6	15
5h16encoded	k x (12,8/16,0/19,2/ 24,0/25,6)	(U32e, E320)	I_{PX}	lim	Yes, code	25,6	15
5h64encoded	k x (16,0/19,2/24,0/ 28,8/36,0/38,4)	(U48e, E48)	I_{PX}	lim	Yes, code	38,4	15
<p>ST: Service Type: x dy = type x double slot, modulation y levels; x ly = type x long slot (j=640 or j=672), modulation y levels; x fy = type x full slot, modulation y levels; x hy = type x half slot, modulation y levels; f = 0 for 2-level modulation in A field; f = 64 for 4-level modulation in A field; f = 128 for 8-level modulation in A field; ssub = single subfield protected B-field format. Encoded = Encoded protected B-field format; the I channel capacity varies in function of the adaptive code rate r.</p> <p>NP: I_N channel or I_P channel.</p> <p>Err. det.: error detection capability.</p> <p>Err. corr.: error correction capability (based on channel coding (see note 10)).</p> <p>max. C_F: maximum C_F channel throughput</p> <p>dly: approximate delay incurred by I channel data in ms. "var" is variable.</p> <p>t: the target number of duplex bearers; $w \leq t$.</p> <p>k: the actual number of duplex bearers; $w \leq k \leq t$.</p> <p>lim: limited capacity. See note 9 in this clause.</p> <p>NOTE: Refer to clause 6.2.2.2 for details of B-field multiplex schemes.</p>							

5.6.2.2 Asymmetric connections

A DECT connection is called asymmetric if it includes double simplex bearers and, as consequence of it, has different number of bearers in both directions.

NOTE 1: Simplex bearers are always allocated in pairs. A pair of simplex bearers in opposite directions is called "duplex bearer". A pair of simplex bearers in the same direction is called "double simplex bearer". In both cases, pairs of simplex bearers are one half TDMA frame apart.

General principles:

- an asymmetric connection is composed of d duplex bearers plus s double simplex bearers, with both $d \geq 1$, $s \geq 1$;
- all double-simplex bearers shall go in the same direction. The direction of the double-simplex bearers is, by definition, called the "forward direction" of the connection. The opposite one is the "backward direction";

- c) there exist k simplex bearers in the forward direction, being $k = d + 2*s$;
- d) there exist $m + n$ simplex bearers in the backward direction being $m + n = d$;

NOTE 2: $k \geq m + n \geq 1$ in all cases.

- e) the n simplex bearers in the reverse direction are called "special" bearers. These bearers shall be in E-type or E+U-type multiplexer mode (see clause 6.2.2.2) and shall carry the "Bearer quality in an asymmetric connection" message in subfield B0. They are used to report reception quality on the double simplex bearers in the forward data direction and to carry G_F channel data. These special bearers shall not carry I_N or I_P , channel data, however, if the mode is E+U type, they can carry I_{PF} channel data, and if the mode is E-type, they can carry C_F channel signalling;

NOTE 3: A special bearer is, by definition, a reverse bearer carrying the "Bearer quality report in an asymmetric connection" message.

- f) the number of special bearers shall be $n \geq 1$. However, some profiles could allow, by negotiation, to drop the number of n bearers to $n = 0$ in some cases. In such situation the n bearer becomes an m bearer. In all cases $(n + m) \geq 1$;

NOTE 4: It should be assumed that the most usual case will be $n=1$ (one special bearer).

NOTE 5: The suppression of the "Bearer quality in an asymmetric connection" ($n=0$) deactivates the DECT basic quality feedback mechanism (bits Q1/Q2), and should only be used under very good and steady radio quality conditions (i.e.: very short range links). In case of incidental air interface errors, the message "Bearer and connection control" could be used by the receiver side to request handover or antenna switch. However, this mechanism has slower response time and a limited control capability and will not handle properly the case of simultaneous loss of quality on several bearers.

- g) the m simplex bearers in the reverse direction shall be normally in U-type multiplexer mode and carry I_N , or I_P channel data. However, it is allowed to switch occasionally them to E or E+U type mode to exchange signalling messages (channels M, G_F or C_F) if the capacity of the n bearers is not enough. During the time the bearer is in E or E+U type mode it cannot carry I_N or I_P . If the mode is E+U type, they can carry I_{PF} channel data;

NOTE 6: The number of m bearers can be zero, however $n + m \geq 1$.

- h) all the k simplex bearers in the forward direction shall be normally in U-type multiplexer mode. However, from time to time, some of them can be switched to E or E+U type mode to exchange signalling messages (channels M, G_F or C_F). During the time the bearer is in E or E+U type mode it cannot carry I_N or I_P channel data. However, if the mode is E+U type, they can carry I_{PF} channel data.

NOTE 7: Only the bearers that are part of a duplex bearer can be switched to E-type or E+U-type mux mode.

NOTE 8: It is not recommended to switch forward bearers to E or E+U type mux only to carry G_F channel. Instead of it, the alternative mechanisms provided by some LU services (i.e. LU10) may be used.

The four asymmetric service types are distinguished by their I channel data protection and their throughput:

- type 6: $I_{N_normal_delay}$ (I_{NB}): limited error protection, half-frame synchronization, fixed delay, fixed throughput;
- type 7: $I_{P_error_detection}$: error detection capability, minimum delay, fixed throughput; The type 7, $I_{P_error_detection}$ service may be:
- type 7a: (IPM); $I_{P_error_detection}$ using multi-subfield protected B-field format (as clause 6.2.1.3.3);
 - type 7b: (IPQ); $I_{P_error_detection}$ using single subfield protected B-field format (as clause 6.2.1.3.4);
 - type 7c: (IPK); $I_{P_error_detection}$ using constant-size subfield protected B-field format (as clause 6.2.1.3.5);

- type 8: $I_{p_error_correction}$: error correction, variable throughput; The type 8, $I_{p_error_correction}$ service may be:
- type 8a: (IPMR); $I_{p_error_correction}$ using multi-subfield protected B-field format (as clause 6.2.1.3.3);
 - type 8b: (IPQR); $I_{p_error_correction}$ using single subfield protected B-field format (as clause 6.2.1.3.4);
 - type 8c: (IPKR); $I_{p_error_correction}$ using constant-size subfield protected B-field format (as clause 6.2.1.3.5);
- type 9: $I_{p_encoded_protected}$ (I_{pX}).

Tables 5.4 to 5.6 show the most important parameters for asymmetric connections. The first line in each description defines the forward data direction. The second and third line describe the reverse direction on normal bearers (m) and on special (n) bearers. The total throughput in backward direction is the sum of lines 2 and 3.

NOTE 9: In the channel capacity calculations, it is assumed that the all bearers of the forward channel are in U-type mux mode, since the switch to E-type or E+U-type only happens occasionally.

NOTE 10: In the MAC service IN_normal_delay (INB), the MAC layer guarantees a constant delay that only depends of the timing between arrival of external data and the position of the DECT frame boundary. The MAC layer also guarantees the sequencing of packets in Multibearer connections, and the repetition of same data in both bearers during the bearer handover.

NOTE 11: In all other MAC services ($IN_minimum_delay$, IP_error_detect , $IP_error_correct$, $IP_encoded_protected$) there can be variations in the actual delay as result of changes in the slot position(s) used in the link (that may change due to bearer handovers and replacements). Depending on the application and the operation of higher layers, this variation could be irrelevant, or may produce packet duplication or loss during the bearer changes.

Table 5.4: Asymmetric services (2-level modulation)

ST	I channel capacity (kbit/s) Forward channel Backward channel m bearers backward channel n bearers	B-field multiplex schemes	NP	Err det.	Err corr.	max. C_F (kbit/s)
6d2	k x 80 m x 80 variable: 0 to (n x 6,4 x 9)	(U80a,E80) (U80a,E80) (E80)	I_{NB} I_{NB} I_{PF}	No No Yes	No No No	d x 64,0 m x 64,0 n x 57,6 (note 1)
6l2 (j=640)	k x 64 m x 64 variable: 0 to (n x 6,4 x 7)	(U64a,E64) (U64a,E64) (E64)	I_{NB} I_{NB} I_{PF}	No No Yes	No No No	d x 51,2 m x 51,2 n x 44,8 (note 1)
6l2 (j=672)	k x 67,2 m x 67,2 variable: 0 to (n x 6,4 x 7)	(U67a, E67) (U67a, E67) (E67)	I_{NB} I_{NB} I_{PF}	No No Yes	No No No	d x 51,2 m x 51,2 n x 44,8 (note 1)
6f2	k x 32 m x 32 variable: 0 to (n x 6,4 x 3)	(U32a,E32) (U32a,E32) (E32)	I_{NB} I_{NB} I_{PF}	No No Yes	No No No	d x 25,6 m x 25,6 n x 19,2 (note 1)
7d2	k x 64 m x 64 variable: 0 to (n x 6,4 x 9)	(U80b,E80) (U80b,E80) (E80)	I_{PM} I_{PM} I_{PF}	Yes Yes Yes	No No No	d x 64,0 m x 64,0 n x 57,6 (note 1)
7l2 (j=640)	k x 51,2 m x 51,2 variable: 0 to (n x 6,4 x 7)	(U64b,E64) (U64b,E64) (E64)	I_{PM} I_{PM} I_{PF}	Yes Yes Yes	No No No	d x 51,2 m x 51,2 n x 44,8 (note 1)
7l2 (j=672)	k x 51,2 m x 51,2 variable: 0 to (n x 6,4 x 7)	(U67b,E67) (U67b,E67) (E67)	I_{PM} I_{PM} I_{PF}	Yes Yes Yes	No No No	d x 51,2 m x 51,2 n x 44,8 (note 1)

ST	I channel capacity (kbit/s) Forward channel Backward channel m bearers backward channel n bearers	B-field multiplex schemes	NP	Err det.	Err corr.	max. C _F (kbit/s)
7f2	k x 25,6 m x 25,6 variable: 0 to (n x 6,4 x 3)	(U32b,E32) (U32b,E32) (E32)	I _{PM} I _{PM} I _{PF}	Yes Yes Yes	No No No	d x 25,6 m x 25,6 n x 19,2 (note 1)
7d2ssub	k x 76,8 m x 76,8 variable: 0 to (n x 6,4 x 9)	(U80c) (U80c) (E80)	I _{PQ} I _{PQ} I _{PF}	Yes Yes Yes	No No No	d x 64,0 m x 64,0 n x 57,6 (note 1)
7l2ssub (j=640)	k x 60,8 m x 60,8 variable: 0 to (n x 6,4 x 7)	(U64c) (U64c) (E64)	I _{PQ} I _{PQ} I _{PF}	Yes Yes Yes	No No No	d x 51,2 m x 51,2 n x 44,8 (note 1)
7l2ssub (j=672)	k x 64 m x 64 variable: 0 to (n x 6,4 x 7)	(U67c) (U67c) (E67)	I _{PQ} I _{PQ} I _{PF}	Yes Yes Yes	No No No	d x 51,2 m x 51,2 n x 44,8 (note 1)
7f2ssub	k x 30,4 m x 30,4 variable: 0 to (n x 6,4 x 3)	(U32c) (U32c) (E32)	I _{PQ} I _{PQ} I _{PF}	Yes Yes Yes	No No No	d x 25,6 m x 25,6 n x 19,2 (note 1)
7d2csub	k x 76,8 m x 76,8 variable: 0 to (n x 6,4 x 9)	(U80d) (U80d) (E80)	I _{PK} I _{PK} I _{PF}	Yes Yes Yes	No No No	d x 64,0 m x 64,0 n x 57,6 (note 1)
7l2csub (j=640)	k x 60,8 m x 60,8 variable: 0 to (n x 6,4 x 7)	(U64d) (U64d) (E64)	I _{PK} I _{PK} I _{PF}	Yes Yes Yes	No No No	d x 51,2 m x 51,2 n x 44,8 (note 1)
7l2csub (j=672)	k x 64 m x 64 variable: 0 to (n x 6,4 x 7)	(U67d) (U67d) (E67)	I _{PK} I _{PK} I _{PF}	Yes Yes Yes	No No No	d x 51,2 m x 51,2 n x 44,8 (note 1)
7f2csub	k x 30,4 m x 30,4 variable: 0 to (n x 6,4 x 3)	(U32d) (U32d) (E32)	I _{PK} I _{PK} I _{PF}	Yes Yes Yes	No No No	d x 25,6 m x 25,6 n x 19,2 (note 1)
8d2	≤ k x 64 ≤ m x 64 variable: 0 to (n x 6,4 x 9)	(U80b,E80) (U80b,E80) (E80)	I _{PMR} I _{PMR} I _{PF}	Yes Yes Yes	Yes, ARQ Yes, ARQ Yes, ARQ	d x 64,0 m x 64,0 n x 57,6 (note 1)
8l2 (j=640)	≤ k x 51,2 ≤ m x 51,2 variable: 0 to (n x 6,4 x 7)	(U64b,E64) (U64b,E64) (E64)	I _{PMR} I _{PMR} I _{PF}	Yes Yes Yes	Yes, ARQ Yes, ARQ Yes, ARQ	d x 51,2 m x 51,2 n x 44,8 (note 1)
8l2 (j=672)	≤ k x 51,2 ≤ m x 51,2 variable: 0 to (n x 6,4 x 7)	(U67b,E67) (U67b,E67) (E67)	I _{PMR} I _{PMR} I _{PF}	Yes Yes Yes	Yes, ARQ Yes, ARQ Yes, ARQ	d x 51,2 m x 51,2 n x 44,8 (note 1)
8f2	≤ k x 25,6 ≤ m x 25,6 variable: 0 to (n x 6,4 x 3)	(U32b,E32) (U32b,E32) (E32)	I _{PMR} I _{PMR} I _{PF}	Yes Yes Yes	Yes, ARQ Yes, ARQ Yes, ARQ	d x 25,6 m x 25,6 n x 19,2 (note 1)
8d2ssub	≤ k x 76,8 ≤ m x 76,8 variable: 0 to (n x 6,4 x 9)	(U80c) (U80c) (E80)	I _{PQR} I _{PQR} I _{PF}	Yes Yes Yes	Yes, ARQ Yes, ARQ Yes, ARQ	d x 64 m x 64 n x 57,6 (note 1)
8l2ssub (j=640)	k x 60,8 m x 60,8 variable: 0 to (n x 6,4 x 7)	(U64c) (U64c) (E64)	I _{PQR} I _{PQR} I _{PF}	Yes Yes Yes	Yes, ARQ Yes, ARQ Yes, ARQ	d x 51,2 m x 51,2 n x 44,8 (note 1)

ST	I channel capacity (kbit/s) Forward channel Backward channel m bearers backward channel n bearers	B-field multiplex schemes	NP	Err det.	Err corr.	max. C _F (kbit/s)
8l2ssub (j=672)	k x 64 m x 64 variable: 0 to (n x 6,4 x 7)	(U67c) (U67c) (E67)	I _{PQR} I _{PQR} I _{PF}	Yes Yes Yes	Yes, ARQ Yes, ARQ Yes, ARQ	d x 51,2 m x 51,2 n x 44,8 (note 1)
8f2ssub	≤ k x 30,4 ≤ m x 30,4 variable: 0 to (n x 6,4 x 3)	(U32c) (U32c) (E32)	I _{PQR} I _{PQR} I _{PF}	Yes Yes Yes	Yes, ARQ Yes, ARQ Yes, ARQ	d x 51,2 m x 51,2 n x 19,2 (note 1)
8d2csub	≤ k x 76,8 ≤ m x 76,8 variable: 0 to (n x 6,4 x 9)	(U80d) (U80d) (E80)	I _{PK} I _{PK} I _{PF}	Yes Yes Yes	Yes, ARQ Yes, ARQ Yes, ARQ	d x 64 m x 64 n x 57,6 (note 1)
8l2csub (j=640)	k x 60,8 m x 60,8 variable: 0 to (n x 6,4 x 7)	(U64d) (U64d) (E64)	I _{PK} I _{PK} I _{PF}	Yes Yes Yes	Yes, ARQ Yes, ARQ Yes, ARQ	d x 51,2 m x 51,2 n x 44,8 (note 1)
8l2csub (j=672)	k x 64 m x 64 variable: 0 to (n x 6,4 x 7)	(U67d) (U67d) (E67)	I _{PK} I _{PK} I _{PF}	Yes Yes Yes	Yes, ARQ Yes, ARQ Yes, ARQ	d x 51,2 m x 51,2 n x 44,8 (note 1)
8f2csub	≤ k x 30,4 ≤ m x 30,4 variable: 0 to (n x 6,4 x 3)	(U32d) (U32d) (E32)	I _{PK} I _{PK} I _{PF}	Yes Yes Yes	Yes, ARQ Yes, ARQ Yes, ARQ	d x 51,2 m x 51,2 n x 19,2 (note 1)
9d2encoded	≤ k x (60,0/64,0/80,0) x r ≤ m x (60,0/64,0/80,0) x r variable: 0 to (n x 6,4 x 9)	(U80e,E80) (U80e,E80) (E80)	I _{PX} I _{PX} I _{PF}	lim lim Yes	Yes, code Yes, code No	d x 64 m x 64 n x 57,6 (note 1)
9l2encoded (j=640)	≤ k x (48,0/51,2/64,0) x r ≤ m x (48,0/51,2/64,0) x r variable: 0 to (n x 6,4 x 7)	(U64e,E64) (U64e,E64) (E64)	I _{PX} I _{PX} I _{PF}	lim lim Yes	Yes, code Yes, code No	d x 51,2 m x 51,2 n x 44,8 (note 1)
9f2encoded	≤ k x (24,0/25,6/32,0) x r ≤ m x (24,0/25,6/32,0) x r variable: 0 to (n x 6,4 x 3)	(U32e,E32) (U32e,E32) (E32)	I _{PX} I _{PX} I _{PF}	lim lim Yes	Yes, code Yes, code No	d x 25,6 m x 25,6 n x 19,2 (note 1)
<p>ST: Service Type: x_{dy} = type x double slot, y levels modulation; x_{ly} = type x long slot (j=640 or j=672), y levels modulation; x_{fy} = type x full slot, y levels modulation; x_h = type x half slot, where x = the Service Type; ssub = singlesubfield protected B-field format. Encoded = Encoded protected B-field format; the I channel capacity varies in function of the adaptive code rate r.</p> <p>NP: Name of the U-plane channel (I_N, I_P, or I_{PF}).</p> <p>err.det.: error detection capability.</p> <p>err.corr.: error correction capability and type (ARQ or channel coding).</p> <p>max.C_F: maximum C_F channel throughput.</p> <p>k: the actual number of simplex bearers in the forward direction.</p> <p>m: the actual number of simplex data bearers in the reverse direction with U-type mux.</p> <p>n: the actual number of simplex special bearers in the reverse direction.</p> <p>lim: limited error detection capability. See note 13.</p>						
NOTE 1: The C _F capacity in n bearers includes the reduction due to the "Bearer quality in an asymmetric connection" sent on this bearer.						
NOTE 2: Refer to clause 6.2.2.2 for details of B-field multiplex schemes.						

NOTE 12: The delay for each service can be considered approximately equal to the delay for equivalent symmetric service. See table 5.1 in clause 5.6.2.1 and notes 4 to 8 in the same clause. For double simplex bearers there is in theory, a reduction in the delay due to the use of the second half of the frame. However it depends on the specific scenario of bearers and slot positions.

NOTE 13: The error detection capability for the $I_{P_}$ encoded protected service (I_{PX}) is limited. There is no error detection capability when r parameter is equal to 1.

NOTE 14: The error correction capability for the $I_{P_}$ encoded protected service (I_{PX}) depends on r rate. There is no error correction capability when r parameter is equal to 1.

Table 5.5: Asymmetric services (4-level and 8-level modulation)

ST	I channel capacity (kbit/s)	B-field multiplex schemes	NP	Err det.	Err corr.	max. C_F (kbit/s)
6d4	k x 160 m x 160 variable	(U160a,E160) (U160a,E160) (E160)	I_{NB}	No	No	128,0
			I_{NB}	No	No	128,0
			I_{PF}	Yes	No	var (note 1)
6d8	k x 240 m x 240 variable	(U240a,E240) (U240a,E240) (E240)	I_{NB}	No	No	192,0
			I_{NB}	No	No	192,0
			I_{PF}	Yes	No	var (note 1)
6l4 (j=640)	k x 128 m x 128 variable	(U128a,E128) (U128a,E128) (E128)	I_{NB}	No	No	102,4
			I_{NB}	No	No	102,4
			I_{PF}	Yes	No	var (note 1)
6l8 (j=640)	k x 192 m x 192 variable	(U192a,E192) (U192a,E192) (E192)	I_{NB}	No	No	153,6
			I_{NB}	No	No	153,6
			I_{PF}	Yes	No	var (note 1)
6l4 (j=672)	k x 134,4 m x 134,4 variable	(U134a, E134) (U134a, E134) (E134)	I_{NB}	No	No	102,4
			I_{NB}	No	No	102,4
			I_{PF}	Yes	No	var (note 1)
6l8 (j=672)	k x 201,6 m x 201,6 variable	(U201a, E201) (U201a, E201) (E201)	I_{NB}	No	No	153,6
			I_{NB}	No	No	153,6
			I_{PF}	Yes	No	var (note 1)
6f4	k x 64 m x 64 variable	(U64a,E64) (U64a,E64) (E64)	I_{NB}	No	No	51,2
			I_{NB}	No	No	51,2
			I_{PF}	Yes	No	var (note 1)
6f8	k x 96 m x 96 variable	(U96a,E96) (U96a,E96) (E96)	I_{NB}	No	No	76,8
			I_{NB}	No	No	76,8
			I_{PF}	Yes	No	var (note 1)
7d4	k x 128 m x 128 variable	(U160b,E160) (U160b,E160) (E160)	I_{PM}	Yes	No	128,0
			I_{PM}	Yes	No	128,0
			I_{PF}	Yes	No	var (note 1)
7d8	k x 192 m x 192 variable	(U240b,E240) (U240b,E240) (E240)	I_{PM}	Yes	No	192,0
			I_{PM}	Yes	No	192,0
			I_{PF}	Yes	No	var (note 1)
7l4 (j=640)	k x 102,4 m x 102,4 variable	(U128b,E128) (U128b,E128) (E128)	I_{PM}	Yes	No	102,4
			I_{PM}	Yes	No	102,4
			I_{PF}	Yes	No	var (note 1)
7l8 (j=640)	k x 153,6 m x 153,6 variable	(U192b,E192) (U192b,E192) (E192)	I_{PM}	Yes	No	153,6
			I_{PM}	Yes	No	153,6
			I_{PF}	Yes	No	var (note 1)
7l4 (j=672)	k x 102,4 m x 102,4 variable	(U134b,E134) (U134b,E134) (E134)	I_{PM}	Yes	No	102,4
			I_{PM}	Yes	No	102,4
			I_{PF}	Yes	No	var (note 1)
7l8 (j=672)	k x 153,6 m x 153,6 variable	(U201b,E201) (U201b,E201) (E201)	I_{PM}	Yes	No	153,6
			I_{PM}	Yes	No	153,6
			I_{PF}	Yes	No	var (note 1)
7f4	k x 51,2 m x 51,2 variable	(U64b,E64) (U64b,E64) (E64)	I_{PM}	Yes	No	51,2
			I_{PM}	Yes	No	51,2
			I_{PF}	Yes	No	var (note 1)

ST	l channel capacity (kbit/s)	B-field multiplex schemes	NP	Err det.	Err corr.	max. C _F (kbit/s)
7f8	k x 76,8 m x 76,8 variable	(U96b,E96) (U96b,E96) (E96)	I _{PM} I _{PM} I _{PF}	Yes Yes Yes	No No No	76,8 76,8 var (note 1)
7d4ssub	k x 156,8 m x 156,8 variable	(U160c) (U160c) (E160)	I _{PQ} I _{PQ} I _{PF}	Yes Yes Yes	No No No	128,0 128,0 var (note 1)
7d8ssub	k x 236,8 m x 236,8 variable	(U240c) (U240c) (E240)	I _{PQ} I _{PQ} I _{PF}	Yes Yes Yes	No No No	192,0 192,0 var (note 1)
7l4ssub (j=640)	k x 124,8 m x 124,8 variable	(U128c) (U128c) (E128)	I _{PQ} I _{PQ} I _{PF}	Yes Yes Yes	No No No	102,4 102,4 var (note 1)
7l8ssub (j=640)	k x 188,8 m x 188,8 variable	(U192c) (U192c) (E192)	I _{PQ} I _{PQ} I _{PF}	Yes Yes Yes	No No No	153,6 153,6 var (note 1)
7l4ssub (j=672)	k x 131,2 m x 131,2 variable	(U134c) (U134c) (E134)	I _{PQ} I _{PQ} I _{PF}	Yes Yes Yes	No No No	102,4 102,4 var (note 1)
7l8ssub (j=672)	k x 198,4 m x 198,4 variable	(U201c) (U201c) (E201)	I _{PQ} I _{PQ} I _{PF}	Yes Yes Yes	No No No	153,6 153,6 var (note 1)
7f4ssub	k x 60,8 m x 60,8 variable	(U64c) (U64c) (E64)	I _{PQ} I _{PQ} I _{PF}	Yes Yes Yes	No No No	51,2 51,2 var (note 1)
7f8ssub	k x 92,8 m x 92,8 variable	(U96c) (U96c) (E96)	I _{PQ} I _{PQ} I _{PF}	Yes Yes Yes	No No No	76,8 76,8 var (note 1)
7d4csub	k x 153,6 m x 153,6 n x 0	(U160d) (U160d) (E160)	I _{PK} I _{PK} I _{PF}	Yes Yes Yes	No No No	128,0 128,0 var (note 1)
7d8csub	k x 230,8 m x 230,8 n x 0	(U240d) (U240d) (E240)	I _{PK} I _{PK} I _{PF}	Yes Yes Yes	No No No	192,0 192,0 var (note 1)
7l4csub (j=640)	k x 121,6 m x 121,6 n x 0	(U128d) (U128d) (E128)	I _{PK} I _{PK} I _{PF}	Yes Yes Yes	No No No	102,4 102,4 var (note 1)
7l8csub (j=640)	k x 182,4 m x 182,4 n x 0	(U192d) (U192d) (E192)	I _{PK} I _{PK} I _{PF}	Yes Yes Yes	No No No	153,6 153,6 var (note 1)
7l4csub (j=672)	k x 128 m x 128 n x 0	(U134d) (U134d) (E134)	I _{PK} I _{PK} I _{PF}	Yes Yes Yes	No No No	102,4 102,4 var (note 1)
7l8csub (j=672)	k x 192 m x 192 n x 0	(U201d) (U201d) (E201)	I _{PK} I _{PK} I _{PF}	Yes Yes Yes	No No No	153,6 153,6 var (note 1)
7f4csub	k x 60,8 m x 60,8 n x 0	(U64d) (U64d) (E64)	I _{PK} I _{PK} I _{PF}	Yes Yes Yes	No No No	51,2 51,2 var (note 1)
7f8csub	k x 91,2 m x 91,2 n x 0	(U96d) (U96d) (E96)	I _{PK} I _{PK} I _{PF}	Yes Yes Yes	No No No	76,8 76,8 var (note 1)

ST	I channel capacity (kbit/s)	B-field multiplex schemes	NP	Err det.	Err corr.	max. C _F (kbit/s)
8d4	≤ k x 128 ≤ m x 128 variable	(U160b,E160) (U160b,E160) (E160)	I _{PMR} I _{PMR} I _{PF}	Yes Yes Yes	Yes, ARQ Yes, ARQ No	128,0 128,0 var (note 1)
8d8	≤ k x 192 ≤ m x 192 variable	(U240b,E240) (U240b,E240) (E240)	I _{PMR} I _{PMR} I _{PF}	Yes Yes Yes	Yes, ARQ Yes, ARQ No	192,0 192,0 var (note 1)
8l4 (j=640)	≤ k x 102,4 ≤ m x 102,4 variable	(U128b,E128) (U128b,E128) (E128)	I _{PMR} I _{PMR} I _{PF}	Yes Yes Yes	Yes, ARQ Yes, ARQ No	102,4 102,4 var (note 1)
8l8 (j=640)	≤ k x 153,6 ≤ m x 153,6 variable	(U192b,E192) (U192b,E192) (E192)	I _{PMR} I _{PMR} I _{PF}	Yes Yes Yes	Yes, ARQ Yes, ARQ No	153,6 153,6 var (note 1)
8l4 (j=672)	≤ k x 102,4 ≤ m x 102,4 variable	(U134b,E134) (U134b,E134) (E134)	I _{PMR} I _{PMR} I _{PF}	Yes Yes Yes	Yes, ARQ Yes, ARQ No	102,4 102,4 var (note 1)
8l8 (j=672)	≤ k x 153,6 ≤ m x 153,6 variable	(U201b,E201) (U201b,E201) (E201)	I _{PMR} I _{PMR} I _{PF}	Yes Yes Yes	Yes, ARQ Yes, ARQ No	153,6 153,6 var (note 1)
8f4	≤ k x 51,2 ≤ m x 51,2 variable	(U64b,E64) (U64b,E64) (E64)	I _{PMR} I _{PMR} I _{PF}	Yes Yes Yes	Yes, ARQ Yes, ARQ No	51,2 51,2 var (note 1)
8f8	≤ k x 76,8 ≤ m x 76,8 variable	(U96b,E96) (U96b,E96) (E96)	I _{PMR} I _{PMR} I _{PF}	Yes Yes Yes	Yes, ARQ Yes, ARQ No	76,8 76,8 var (note 1)
8d4ssub	≤ k x 156,8 ≤ m x 156,8 variable	(U160c) (U160c) (E160)	I _{PQR} I _{PQR} I _{PF}	Yes Yes Yes	Yes, ARQ Yes, ARQ No	128,0 128,0 var (note 1)
8d8ssub	≤ k x 236,8 ≤ m x 236,8 variable	(U240c) (U240c) (E240)	I _{PQR} I _{PQR} I _{PF}	Yes Yes Yes	Yes, ARQ Yes, ARQ No	192,0 192,0 var (note 1)
8l4ssub (j=640)	≤ k x 124,8 ≤ m x 124,8 variable	(U128c) (U128c) (E128)	I _{PQR} I _{PQR} I _{PF}	Yes Yes Yes	Yes, ARQ Yes, ARQ No	102,4 102,4 var (note 1)
8l8ssub (j=640)	≤ k x 188,8 ≤ m x 188,8 variable	(U192c) (U192c) (E192)	I _{PQR} I _{PQR} I _{PF}	Yes Yes Yes	Yes, ARQ Yes, ARQ No	153,6 153,6 var (note 1)
8l4ssub (j=672)	≤ k x 131,2 ≤ m x 131,2 variable	(U134c) (U134c) (E134)	I _{PQR} I _{PQR} I _{PF}	Yes Yes Yes	Yes, ARQ Yes, ARQ No	102,4 102,4 var (note 1)
8l8ssub (j=672)	≤ k x 198,4 ≤ m x 198,4 variable	(U201c) (U201c) (E201)	I _{PQR} I _{PQR} I _{PF}	Yes Yes Yes	Yes, ARQ Yes, ARQ No	153,6 153,6 var (note 1)
8f4ssub	≤ k x 60,8 ≤ m x 60,8 variable	(U64c) (U64c) (E64)	I _{PQR} I _{PQR} I _{PF}	Yes Yes Yes	Yes, ARQ Yes, ARQ No	51,2 51,2 var (note 1)
8f8ssub	≤ k x 92,8 ≤ m x 92,8 variable	(U96c) (U96c) (E96)	I _{PQR} I _{PQR} I _{PF}	Yes Yes Yes	Yes, ARQ Yes, ARQ No	76,8 76,8 var (note 1)
8d4csub	≤ k x 153,6 ≤ m x 153,6 n x 0	(U160d) (U160d) (E160)	I _{PKR} I _{PKR} I _{PF}	Yes Yes Yes	Yes, ARQ Yes, ARQ No	128,0 128,0 var (note 1)

ST	I channel capacity (kbit/s)	B-field multiplex schemes	NP	Err det.	Err corr.	max. C _F (kbit/s)
8d8csub	$\leq k \times 230,8$ $\leq m \times 230,8$ $n \times 0$	(U240d) (U240d) (E240)	I _{PKR} I _{PKR} I _{PF}	Yes Yes Yes	Yes, ARQ Yes, ARQ No	192,0 192,0 var (note 1)
8l4csub (j=640)	$\leq k \times 121,6$ $\leq m \times 121,6$ $n \times 0$	(U128d) (U128d) (E128)	I _{PKR} I _{PKR} I _{PF}	Yes Yes Yes	Yes, ARQ Yes, ARQ No	102,4 102,4 var (note 1)
8l8csub (j=640)	$\leq k \times 182,4$ $\leq m \times 182,4$ $n \times 0$	(U192d) (U192d) (E192)	I _{PKR} I _{PKR} I _{PF}	Yes Yes Yes	Yes, ARQ Yes, ARQ No	153,6 153,6 var (note 1)
8l4csub (j=672)	$\leq k \times 128$ $\leq m \times 128$ $n \times 0$	(U134d) (U134d) (E134)	I _{PKR} I _{PKR} I _{PF}	Yes Yes Yes	Yes, ARQ Yes, ARQ No	102,4 102,4 var (note 1)
8l8csub (j=672)	$\leq k \times 192$ $\leq m \times 192$ $n \times 0$	(U201d) (U201d) (E201)	I _{PKR} I _{PKR} I _{PF}	Yes Yes Yes	Yes, ARQ Yes, ARQ No	153,6 153,6 var (note 1)
8f4csub	$\leq k \times 60,8$ $\leq m \times 60,8$ $n \times 0$	(U64d) (U64d) (E64)	I _{PKR} I _{PKR} I _{PF}	Yes Yes Yes	Yes, ARQ Yes, ARQ No	51,2 51,2 var (note 1)
8f8csub	$\leq k \times 91,2$ $\leq m \times 91,2$ $n \times 0$	(U96d) (U96d) (E96)	I _{PKR} I _{PKR} I _{PF}	Yes Yes Yes	Yes, ARQ Yes, ARQ No	76,8 76,8 var (note 1)
9d4encoded	$\leq k \times (80,0/96,0/120,0/$ 128,0/160,0) $\leq m \times (80,0/96,0/120,0/$ 128,0/160,0) variable	(U160e,E160) (U160e,E160) (E160)	I _{PX} I _{PX} I _{PF}	lim lim Yes	Yes, code Yes, code No	128,0 128,0 var (note 1)
9d8encoded	$\leq k \times (120,0/144,0/$ 180,0/192,0) $\leq m \times (120,0/144,0/$ 180,0/192,0) variable	(U240e,E240) (U240e,E240) (E240)	I _{PX} I _{PX} I _{PF}	lim lim Yes	Yes, code Yes, code No	192,0 192,0 var (note 1)
9l4encoded (j=640)	$\leq k \times (64,0/76,8/96,0/$ 102,4/128,0) $\leq m \times (64,0/76,8/96,0/$ 102,4/128,0) variable	(U128e,E128) (U128e,E128) (E128)	I _{PX} I _{PX} I _{PF}	lim lim Yes	Yes, code Yes, code No	102,4 102,4 var (note 1)
9l8encoded (j=640)	$\leq k \times (96,0/115,2/$ 144,0/153,6) $\leq m \times (96,0/115,2/$ 144,0/153,6) variable	(U192e,E192) (U192e,E192) (E192)	I _{PX} I _{PX} I _{PF}	lim lim Yes	Yes, code Yes, code No	153,6 153,6 var (note 1)
9f4encoded	$\leq k \times (32,0/38,4/48,0/$ 51,2/64,0) $\leq m \times (32,0/38,4/48,0/$ 51,2/64,0) variable	(U64e,E64) (U64e,E64) (E64)	I _{PX} I _{PX} I _{PF}	lim lim Yes	Yes, code Yes, code No	51,2 51,2 var (note 1)

ST	I channel capacity (kbit/s)	B-field multiplex schemes	NP	Err det.	Err corr.	max. C _F (kbit/s)
9f8encoded	$\leq k \times (48,0/57,6/72,0/76,8)$	(U96e,E96)	I _{PX}	lim	Yes, code	76,8
	$\leq m \times (48,0/57,6/72,0/76,8)$	(U96e,E96)	I _{PX}	lim	Yes, code	76,8
	variable	(E96)	I _{PF}	Yes	No	var (note 1)
<p>ST: Service Type: x_{dy} = type x double slot, y levels modulation; x_{ly} = type x long slot (j=640 or j=672), y levels modulation; x_{fy} = type x full slot, y levels modulation; f = 0 for 2-level modulation in A-field; f = 64 for 4-level modulation in A field; f = 128 for 8-level modulation in A field; ssub = single subfield protected B-field format. Encoded = Encoded protected B-field format; the I channel capacity varies in function of the adaptive code rate r.</p> <p>NP: I_N channel or I_P channel.</p> <p>err.det.: error detection capability.</p> <p>err.corr.: error correction possibility.</p> <p>max.C_F: maximum C_F channel throughput.</p> <p>k: the actual number of simplex bearers in the forward direction.</p> <p>m: the actual number of simplex data bearers in the reverse direction.</p> <p>n: the actual number of simplex special bearers in the reverse direction.</p> <p>lim: limited error detection capability. See note 13.</p> <p>NOTE 1: Capacity depends of the bandwidth of the I_{PF} channel. Each subfield used by the I_{PF} channel reduces the C_F capacity by 6,4 kbit/s. The compulsory G_F or MAC control message reduces the capacity by additional 6,4 kbit/s. Also, it is expected that the "MAC-Mod2-ACKs" message is normally sent on this bearer, further reducing the C_F capacity by 6,4 kbit/s.</p> <p>NOTE 2: Refer to clause 6.2.2.2 for details of B-field multiplex schemes.</p>						

Table 5.6: Asymmetric services (16-level and 64-level modulation)

ST	I channel capacity (kbit/s)	B-field multiplex schemes	NP	Err det.	Err corr.	max. C _F (kbit/s)
9d16encoded	$\leq k \times (128,0/160,0/192,0/240,0/256,0)$ $\leq m \times (128,0/160,0/192,0/240,0/256,0)$ variable	(U320e,E320)	I _{PX}	lim	Yes, code	256,0
		(U320e,E320)	I _{PX}	lim	Yes, code	256,0
		(E320)	I _{PF}	Yes	No	var (note 1)
9d64encoded	$\leq k \times (160,0/192,0/240,0/288,0/360,0/384,0)$ $\leq m \times (160,0/192,0/240,0/288,0/360,0/384,0)$ variable	(U480e,E480)	I _{PX}	lim	Yes, code	384,0
		(U480e,E480)	I _{PX}	lim	Yes, code	384,0
		(E480)	I _{PF}	Yes	No	var (note 1)
9l16encoded (j=640)	$\leq k \times (102,4/128,0/153,6/192,0/204,8)$ $\leq m \times (102,4/128,0/153,6/192,0/204,8)$ variable	(U256e,E256)	I _{PX}	lim	Yes, code	204,8
		(U256e,E256)	I _{PX}	lim	Yes, code	204,8
		(E256)	I _{PF}	Yes	No	var (note 1)
9l64encoded (j=640)	$\leq k \times (128,0/163,6/192,0/230,4/288,0/307,2)$ $\leq m \times (128,0/163,6/192,0/230,4/288,0/307,2)$ variable	(U384e,E384)	I _{PX}	lim	Yes, code	307,2
		(U384e,E384)	I _{PX}	lim	Yes, code	307,2
		(E384)	I _{PF}	Yes	No	var (note 1)
9f16encoded	$\leq k \times (51,2/64,0/76,8/96,0/102,4)$ $\leq m \times (51,2/64,0/76,8/96,0/102,4)$ variable	(U128e,E128)	I _{PX}	lim	Yes, code	102,4
		(U128e,E128)	I _{PX}	lim	Yes, code	102,4
		(E128)	I _{PF}	Yes	No	var (note 1)
9f64encoded	$\leq k \times (64,0/76,8/96,0/115,2/144,0/153,6)$ $\leq m \times (64,0/76,8/96,0/115,2/144,0/153,6)$ variable	(U192e,E192)	I _{PX}	lim	Yes, code	153,6
		(U192e,E192)	I _{PX}	lim	Yes, code	153,6
		(E192)	I _{PF}	Yes	No	var (note 1)

ST: Service Type:
 xdy = type x double slot, y levels modulation;
 xly = type x long slot (j=640 or j=672), y levels modulation;
 xfy = type x full slot, y levels modulation;
 f = 0 for 2-level modulation in A-field;
 f = 64 for 4-level modulation in A field;
 f = 128 for 8-level modulation in A field.
 Encoded = Encoded protected B-field format; the I channel capacity varies in function of the adaptive code rate r.

NP: I_N channel or I_P channel.

err.det.: error detection capability.

err.corr.: error correction possibility.

max.C_F: maximum C_F channel throughput.

k: the actual number of simplex bearers in the forward direction.

m: the actual number of simplex data bearers in the reverse direction.

n: the actual number of simplex special bearers in the reverse direction.

lim: limited error detection capability. See note 13.

NOTE 1: Capacity depends of the bandwidth of the I_{PF} channel. Each subfield used by the I_{PF} channel reduces the C_F capacity by 6,4 kbit/s. The compulsory G_F or MAC control message reduces the capacity by additional 6,4 kbit/s. Also, it is expected that the "MAC-Mod2-ACKs" message is normally sent on this bearer, further reducing the C_F capacity by 6,4 kbit/s.

NOTE 2: Refer to clause 6.2.2.2 for details of B-field multiplex schemes.

5.7 Broadcast and connectionless services

Most of the broadcast and connectionless services shall be continuous in the downlink direction, i.e. from FT to PT, and non-existent or non-continuous in the uplink direction.

To provide the continuous downlink services a CSF may install one or two bearers which either supports only the broadcast service, i.e. dummy bearers, or which supports the broadcast and the connectionless services, i.e. connectionless bearers.

If two bearers are installed both bearers shall support the same services. The maximum of two bearers for one CSF is only allowed when:

- a) no traffic bearer with downlink transmissions exists at the CSF; and
- b) the FP has multiple RFPs with different FMIDs (see clause 11.7), and provides inter-cell handover capability.

If a CSF uses two bearers for this service, the CSF shall stop transmissions on one of these bearers, (i.e. release the bearer), within 4 multiframe after establishment of the first traffic bearer with downlink transmissions.

The only exception to the above rule applies when the CSF decides to change the physical channel(s) for one of these particular bearers. In this case the CSF may maintain one additional bearer to provide the continuous downlink services for a duration of up to 4 multiframe. At most one bearer for this continuous downlink service may change the physical channel(s) at the time. The number of physical channel changes for this exception shall not exceed 5 changes per any one minute interval.

If a DBC or CBC is selected for the continuous downlink service this bearer shall normally transmit once per frame in downlink direction. The only allowed exception applies for quality control purposes of the chosen physical channel, e.g. RSSI measurements. A DBC or CBC may miss at most one downlink transmission in any one second interval, provided that:

- a) CMC services are not affected (CBC only);
- b) the BMC paging service (see clause 9.1.3) is not affected.

It is further not allowed to miss transmissions in frames 0,8 and 14 of a multiframe (see clause 6.2.2.1.1).

NOTE: If no CMC service is provided, the broadcast service may be offered by a traffic bearer of an ongoing connection. The exception of missing one frame's transmission does not apply for the TBC controlling this traffic bearer.

PT attempts to setup a traffic bearer using the same physical channel(s) as used for a connectionless downlink service shall be ignored by the CSF. With the system capabilities message the FT tells the PT whether or not a bearer setup attempt on dummy bearer(s) is allowed. If setup is prohibited a CSF shall ignore attempts to setup a bearer using the same physical channel as a dummy bearer.

5.7.1 The broadcast services

Two broadcast services are defined, a continuous and a non-continuous broadcast service.

5.7.1.1 The continuous broadcast service

The continuous broadcast service is a simplex service in the direction FT to PT, and is controlled by the BMC.

This service allows PTs to lock on to an FT and to acquire access rights and service related information (see clause 5.2.2). The service is available on all bearers with continuous transmissions in direction FT to PT. This can be a dummy bearer, a traffic bearer or a connectionless bearer.

Each RFP of an FP shall maintain at least one bearer with continuous broadcast transmissions. If an RFP maintains neither a traffic bearer nor a connectionless bearer with continuous transmissions the RFP shall install at least one dummy bearer to provide the broadcast service. Dummy bearers exist only in the downlink direction, i.e. FT to PT.

Data of the continuous broadcast service are always transmitted in the A-field (see clause 6.2.1). The functionality of the service is determined by the rules to distribute data from all broadcast channels into the A-field of consecutive frames within one multiframe (see clause 6.2.2).

5.7.1.2 The non-continuous broadcast service

The non-continuous broadcast service allows the PTs to obtain extended system information on request. This service is controlled by the BMC and works on a transient duplex bearer. The service needs a limited number of transmissions in both directions.

The request and the reply data are transmitted either in the A-field or in the B-field (see clause 6.2.1). The non-continuous broadcast service uses a unique A-field coding for the first transmission in either direction (see clause 7.2.5.6). This is in order to distinguish transmissions of this service from transmissions of other connectionless services.

5.7.2 The connectionless services

The connectionless services allow multicast transmission of higher layer C-plane and U-plane data from an FT to PTs, and point-to-point transmission of higher layer C-plane data from a PT to one FT. These services are controlled by the CMC. The FT to PTs connectionless service may be continuous (i.e. one transmission in every frame). In the direction PT to FT, transmission is limited to a maximum of two slots in two successive frames.

5.7.2.1 Connectionless downlink services

The connectionless downlink service offers a continuous simplex service to the DLC. Only one CMC downlink service may exist within each cluster.

Connectionless bearers used for a downlink service are marked by a special header code and may also be announced by using the BMC service.

A connectionless downlink service shall use CBCs controlling a duplex bearer or, if the CMC does not provide an uplink service, CBCs controlling a simplex bearer. If two CBCs are installed at a CSF to provide the connectionless downlink service all data of this service shall be duplicated on both CBCs.

NOTE 1: The number of allowed CBCs per CSF for connectionless downlink services is restricted (see clause 5.7).

NOTE 2: Connectionless downlink and uplink services are independent.

NOTE 3: A connectionless uplink service may choose another bearer than the duplex bearer which is used for the downlink service.

Four types of continuous connectionless simplex services exist. They are distinguished by the logical channels supported:

- a) only CL_S channel;
- b) CL_S and CL_F channels;
- c) CL_S and SI_N channels;
- d) CL_S and SI_P channels.

Service a) shall always use a short simplex bearer for the downlink. The services b), c) and d) use a long simplex bearer.

5.7.2.2 Connectionless uplink services

This service uses a CBC controlled bearer. Provided that the CBC controls both, the connectionless downlink and uplink service, this bearer is a duplex bearer. Otherwise the CBC controls a simplex bearer. The connectionless uplink service consists of one or two transmissions from the PT to the FT.

The following simplex services are offered to the DLC:

- a) CL_S channel only, one CL_S segment;
- b) CL_F channel only; and
- c) no SDU (only PMID passed to the FT's DLC).

Services a) and c) may use either a short simplex bearer or a long simplex bearer for the uplink. Service b) always uses a long simplex bearer for the uplink. All services may work together with either a short simplex bearer or a long simplex bearer for the downlink.

The PT uses A-field messages to address the RFP and to identify itself.

5.8 ULE Broadcast services

The basic features of this service are covered by clause 5.7, except that the bearers that are used to provide this service are ULE dummy bearers which incorporate standard dummy bearers into their composition. i.e. this service is not provided by any other type of bearer.

There is only a single broadcast service defined, a continuous broadcast service.

5.8.1 The continuous ULE broadcast service

The continuous ULE broadcast service is a simplex service in the direction FT to PT, and is controlled by the BMC. This service allows PTs to lock on to an FT (to which it has already gained access rights during earlier communication), in a single reception. The service is only available on ULE dummy bearers.

Each RFP of a ULE enabled FP shall maintain at least one ULE dummy bearer with continuous broadcast transmissions. ULE dummy bearers exist only in the downlink direction, i.e. FT to PT.

Data of the ULE continuous broadcast service are always transmitted in the B-field (see clause 6.2.1). The functionality of the service is such that all the necessary information to allow a ULE PT to lock to the FT is provided in a single transmission.

6 Multiplexing

To allocate DECT D channel capacity to carry data from all logical channels defined in clause 5.3, several controllers, multiplex algorithms and mapping schemes are used. Figures 6.1 to 6.4 show the four possible MAC layer multiplexing structures, corresponding to the four bearer arrangements.

6.1 CCF multiplexing functions

The MBC establishes and maintains a connection and controls the data flow of the I and C channels. For these purposes the MBC uses MAC control.

In the transmission direction the MBC distributes the data received through the MC SAP to all the TBCs in one connection. This includes the routing of C channel data to one TBC or duplication of this data to more than one TBC and the careful management of data from all channels to two TBCs during seamless bearer handover.

In the receiving direction the MBC collects data from all TBCs. For C channel data the receiving traffic controller removes duplicate data and performs re-sequencing.

For I channel services the MBC is either responsible for resequencing the data or it applies a retransmission scheme to correct transmission errors (see clause 10.8).

Each MBC may contain a key stream generator. This element produces a cipher stream to encrypt or decrypt all I, G_F and C channel data.

The BMC manages and distributes N, Q and B_S channel data, and for ULE enabled systems N_S , Q_C and B_U channel data.

6.2 CSF multiplexing functions

Every TBC or CBC or DBC multiplexes data received from BMC, from CMC and from MBC onto D-fields for delivery to the physical layer. The following functions are defined:

- **MAC control:** MAC control is needed to setup, maintain and release bearers, and to enable/disable encryption.
- **Bit MAPPings (MAP):** MAPs are spatial multiplexers, that combine two or more fields into a single (larger) field. Three MAPs are defined:
 - A-MAP;
 - B-MAP; and
 - D-MAP.
- **Time MULTipleXers (MUX):** MUXs are used to switch between alternative fields on a frame-by-frame basis. They operate synchronously to the applied frame and multiframe timing. Three MUXs are defined:
 - C-MUX;
 - T-MUX; and
 - E/U MUX.
- **Scrambler:** scrambling is used to modify specific data fields every frame according to a standard (predefined) pattern (see clause 6.2.4).
- **Encryption:** encryption is used to modify specific data fields according to a secret pattern denoted KSG in figure 6.1 (see clause 6.2.3). The use of encryption is optional.
- **Error control (CRC):** the error control modules generate extra error control bits (redundancy bits) according to standard cyclic generation algorithms (see clause 6.2.5).
- **Broadcast control:** this is used to merge MAC information with higher layer information as part of the BMC service.

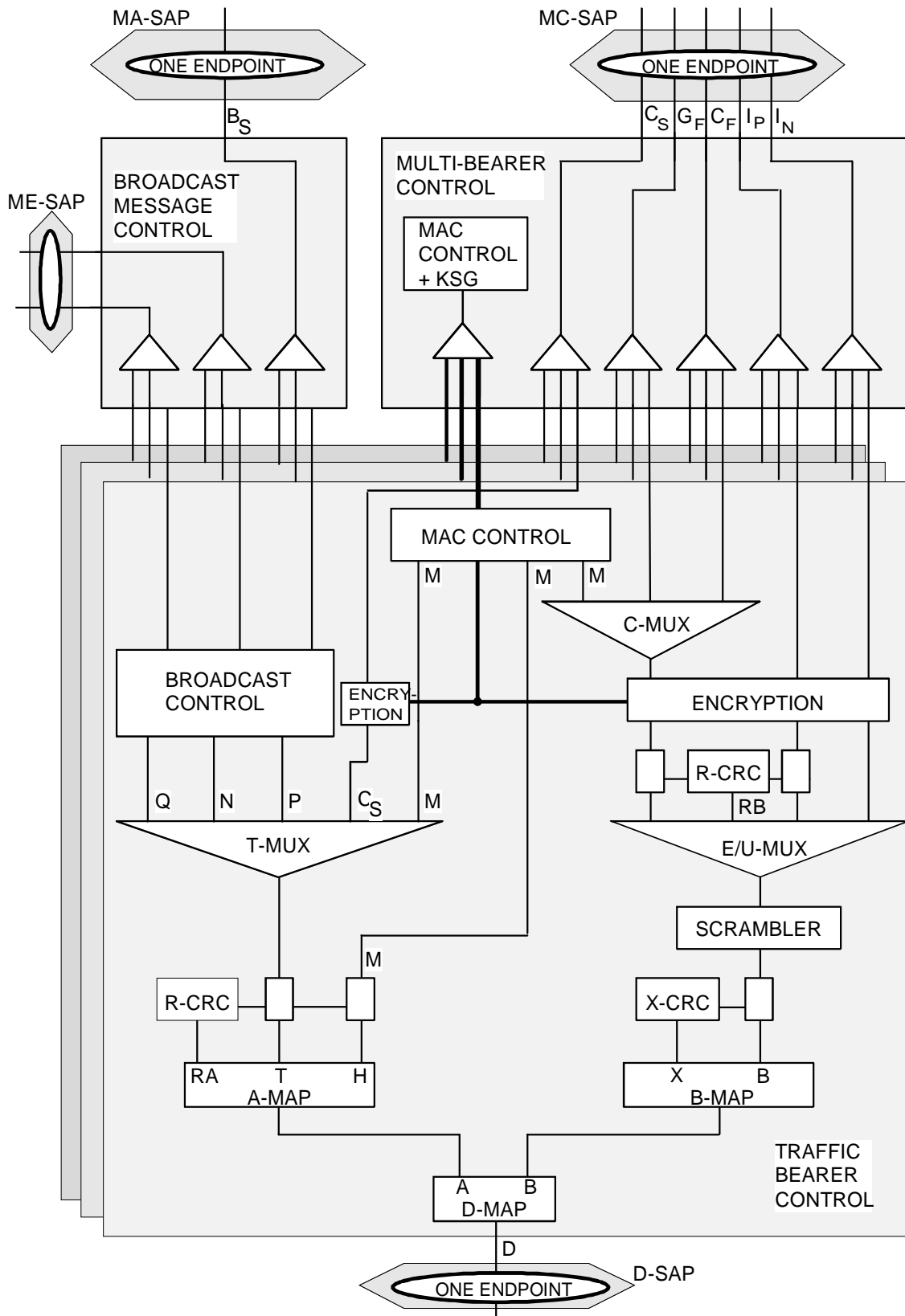

Figure 6.1: TBC multiplexing

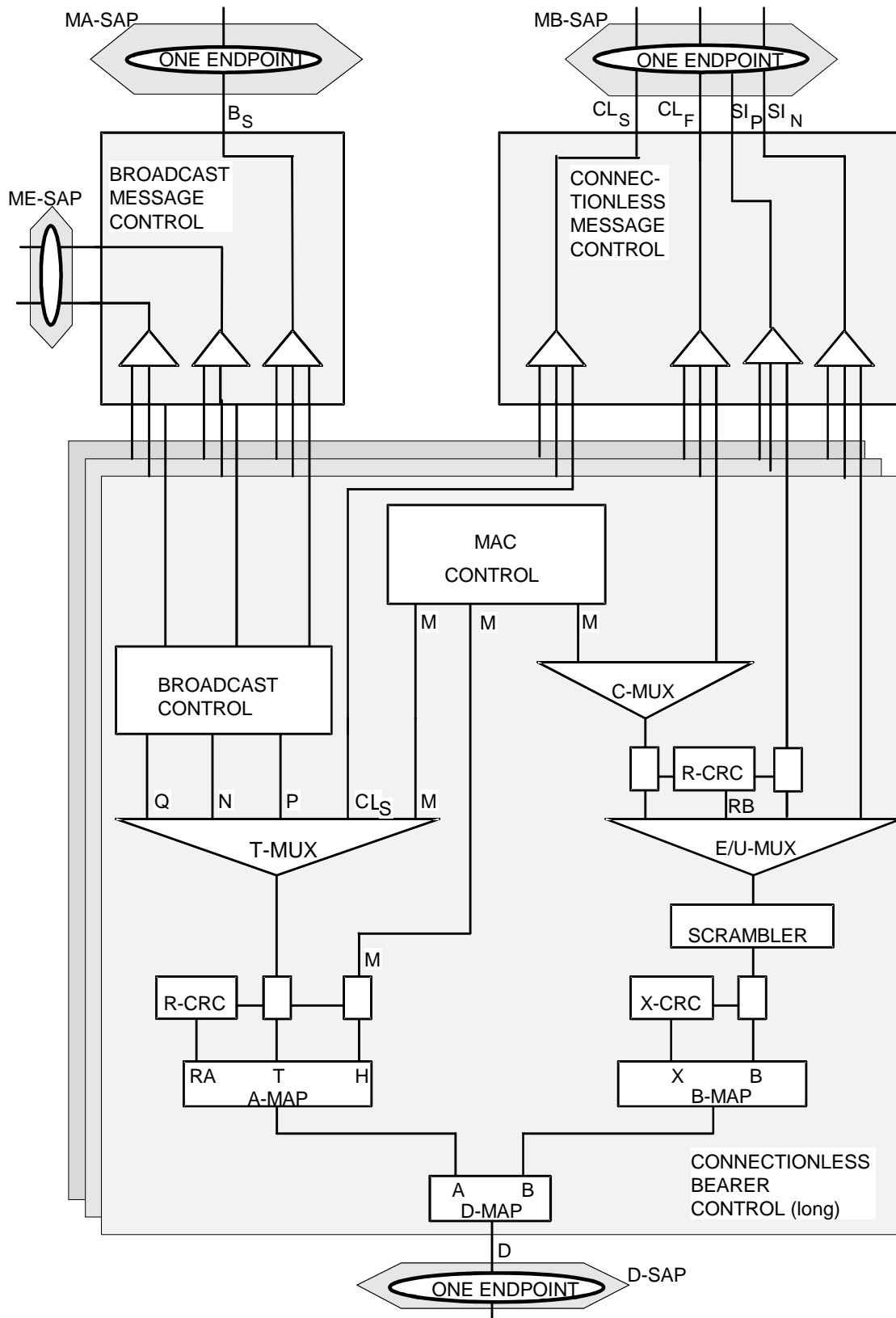

Figure 6.2: CBC multiplexing (long)

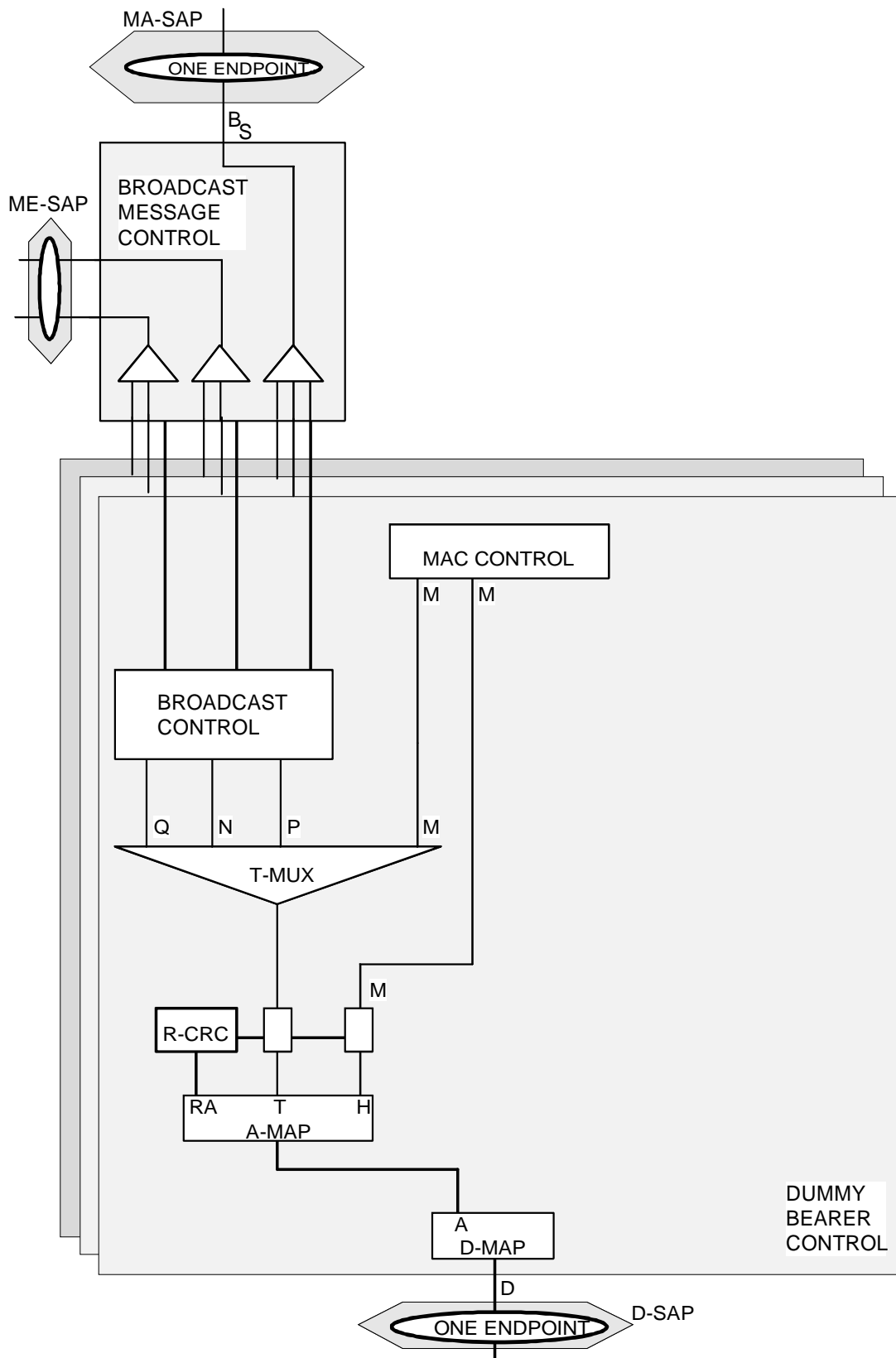

Figure 6.3: DBC multiplexing

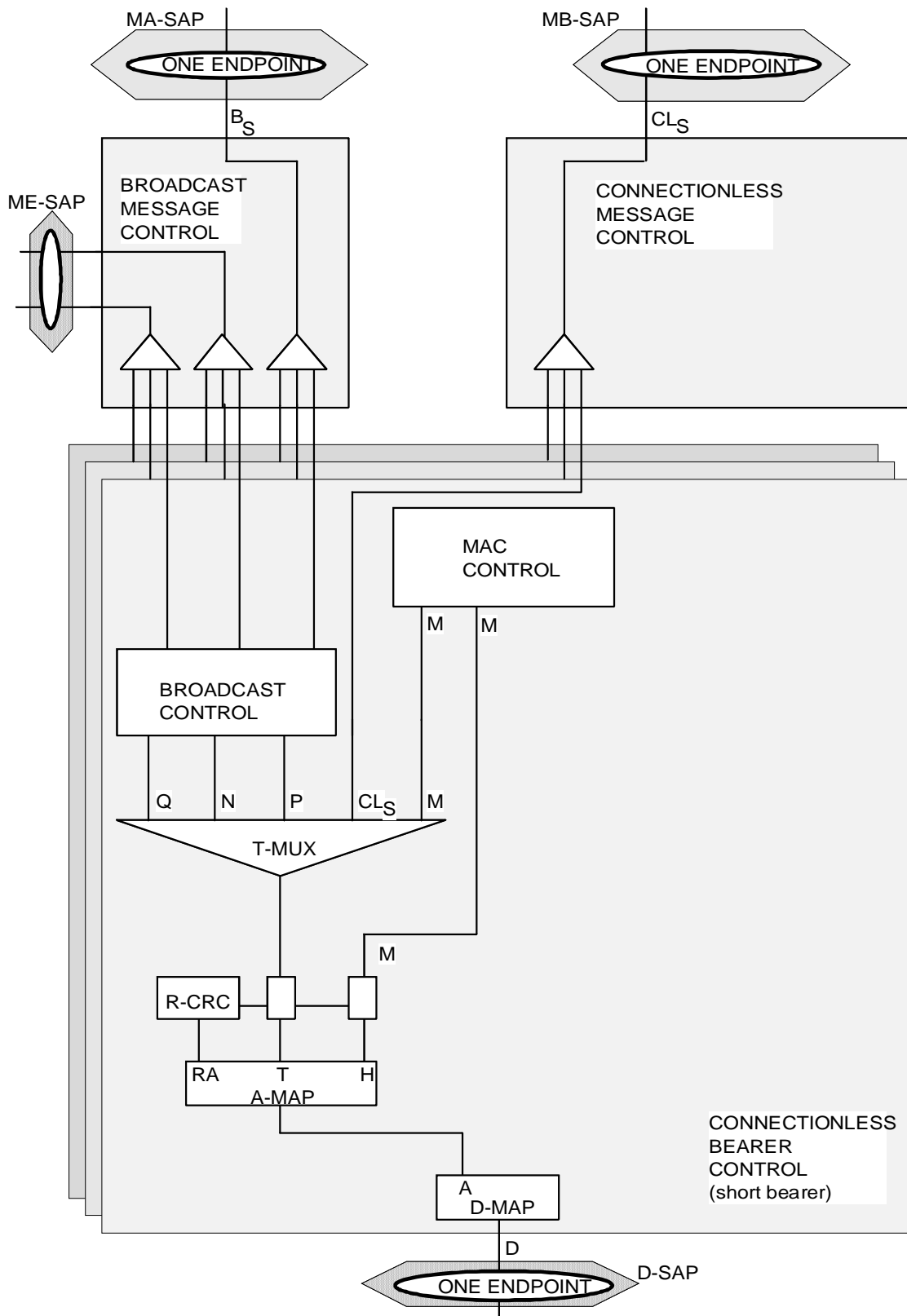

Figure 6.4: CBC multiplexing (short)

6.2.1 Bit Mappings (MAP)

The mapping from the different fields within a timeslot is shown in figure 6.5.

S-field	D-field			Z-field
	A-field	B-field	X-field	

Figure 6.5: Field Mapping within the timeslot

Several modulation levels are defined for the S-, A-, B-, X- and Z-field in EN 300 175-2 [2]. The main combinations of modulation schemes are shown in table 6.1.

Table 6.1: Main combinations of modulation schemes

Configuration	S-field	A-field	B+X+Z-field when E/U mux is in U mode	B+X+Z-field when E/U mux is in E or E+U modes (see note)
1a	GFSK	GFSK	GFSK	GFSK
1b	$\pi/2$ -DBPSK	$\pi/2$ -DBPSK	$\pi/2$ -DBPSK	$\pi/2$ -DBPSK
2	$\pi/2$ -DBPSK	$\pi/2$ -DBPSK	$\pi/4$ -DQPSK	$\pi/4$ -DQPSK
2b	$\pi/2$ -DBPSK	$\pi/2$ -DBPSK	$\pi/4$ -DQPSK	$\pi/2$ -DQPSK
3	$\pi/2$ -DBPSK	$\pi/2$ -DBPSK	$\pi/8$ -D8PSK	$\pi/8$ -D8PSK
3b	$\pi/2$ -DBPSK	$\pi/2$ -DBPSK	$\pi/8$ -DQPSK	$\pi/4$ -DQPSK
4a	$\pi/2$ -DBPSK	$\pi/4$ -DQPSK	$\pi/4$ -DQPSK	$\pi/4$ -DQPSK
4b	$\pi/2$ -DBPSK	$\pi/8$ -D8PSK	$\pi/8$ -D8PSK	$\pi/8$ -D8PSK
5	$\pi/2$ -DBPSK	$\pi/2$ -DBPSK	16-QAM	16-QAM
6	$\pi/2$ -DBPSK	$\pi/2$ -DBPSK	64-QAM	64-QAM

NOTE: See clauses 6.2.2.2 and 6.2.2.3.

All of the mappings follow fixed schemes:

- The A-field mapping (A-MAP) builds the A-field with the header and tail bits. The mapping rules are described in clause 6.2.1.2.
- The B-field mapping (B-MAP) builds the B-field. The mapping rules are described in clause 6.2.1.3.
- The X-field is generated as described in clause 6.2.5.4.
- The D-field mapping (D-MAP) forms the DECT D-field data burst with the A-, B- and X-fields. The mapping rules are described in clause 6.2.1.1.

6.2.1.1 D-field mapping (D-MAP)

All D-fields except D00 are divided into three fields:

- the A-field;
- the B-field;
- the X-field.

These fields vary in size between double slot, full slot and half slot and the various modulation levels.

A D-field is associated to each physical packet and to each modulation configuration as shown in table 6.2.

Table 6.2: Main combinations of D-fields

Configuration	Double slot mode	Full slot mode		Half and long slot mode		
	P80	P32	P00	P00j (j=80)	P00j (j=640)	P00j (j=672)
Configuration	D-field name					
1a	D80a	D32a	D00a	D08a	D64a	D67a
1b	D80b	D32b	D00b	D08b	D64b	D67b
2	D160	D64	D00	D16	D128	D134
2b (see note)	D160/D80b	D64/D32b	D00	D16/D08b	D128/D64b	D134/D67b
3	D240	D96	D00	D24	D192	D201
3b (see note)	D240/D160	D96/D64	D00	D24/D16	D192/D128	D201/D134
4a	D160a	D64a	D00a	D16a	D128a	D134a
4b	D240b	D96b	D00b	D24b	D192b	D201b
5	D320	D128	D00	D32	D256	D268
6	D480	D192	D00	D48	D384	D403

NOTE: In this configuration the first D-field mapping is used when the E/U mux is in U-type mode and the second D-field mapping is used when the E/U mux is in E or E+U type modes.

6.2.1.1.1 D-field mapping for the double slot structure (physical packet P80)

The D-field mapping of the physical packet P80 is shown in figure 6.6. The A-field contains 64 symbols numbered from a_{S0} to a_{S63} , the B-field contains 800 symbols numbered from b_{S0} to b_{S799} and the X-field contains 4 symbols numbered from x_{S0} to x_{S3} . The symbol a_{S0} occurs earlier than the symbol a_{S1} .

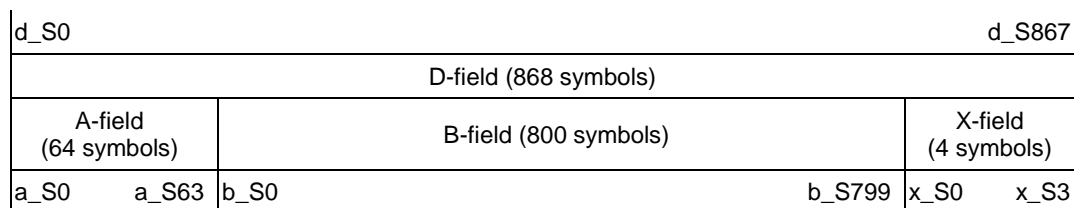

Figure 6.6: A-field, B-field and X-field in the D-field

A D-field name is associated to each modulation configuration as shown in table 6.3.

Table 6.3: D-field mapping for the physical packet P80

Double slot P80					
Configuration	D-field name	D-field (bits)	A-field (bits)	B-field (bits)	X-field (bits)
1a	D80a	868	64	800	4
1b	D80b	868	64	800	4
2	D160	1 672	64	1 600	8
2b (see note)	D160/D80b	1 672/868	64	1 600/800	8/4
3	D240	2 476	64	2 400	12
3b (see note)	D240/D160	2 476/1 672	64	2 400/1 600	12/8
4a	D160a	1 736	128	1 600	8
4b	D240b	2 604	192	2 400	12
5	D320	3 280	64	3 200	16
6	D480	4 888	64	4 800	24

NOTE: In this configuration the first D-field mapping is used when the E/U mux is in U-type mode and the second D-field mapping is used when the E/U mux is in E or E+U type modes.

6.2.1.1.2 D-field mapping for the full slot structure (physical packet P32)

The D-field mapping of the physical packet P32 is shown in figure 6.7. The A-field contains 64 symbols numbered from a_{S0} to a_{S63} , the B-field contains 320 symbols numbered from b_{S0} to b_{S319} and the X-field contains 4 symbols numbered from x_{S0} to x_{S3} . The symbol a_{S0} occurs earlier than the symbol a_{S1} .

d_S0						d_S387
D-field (388 symbols)						
A-field (64 symbols)		B-field (320 symbols)				X-field (4 symbols)
a_S0	a_S63	b_S0				b_S319
				x_S0	x_S3	

Figure 6.7: A-field, B-field and X-field in the D-field

A D-field name is associated to each modulation configuration as shown in table 6.4.

Table 6.4: D-field mapping for the physical packet P32

Full slot P32					
Configuration	D-field name	D-field (bits)	A-field (bits)	B-field (bits)	X-field (bits)
1a	D32a	388	64	320	4
1b	D32b	388	64	320	4
2	D64	712	64	640	8
2b	D64/D32b	712/388	64	640/320	8/4
3	D96	1 036	64	960	12
3b	D96/D64	1 036/712	64	960/640	12/8
4a	D64a	776	128	640	8
4b	D96b	1 164	192	960	12
5	D128	1 360	64	1 280	16
6	D192	2 008	64	1 920	24

NOTE: In this configuration the first D-field mapping is used when the E/U mux is in U-type mode and the second D-field mapping is used when the E/U mux is in E or E+U type modes.

6.2.1.1.3 D-field mapping for the short slot structure (physical packet P00)

The D-field for short slot operation only contains the A-field. The D-field mapping of the physical packet P00 is shown in figure 6.8. The A-field contains 64 symbols numbered from a_{S0} to a_{S63} . The symbol a_{S0} occurs earlier than the symbol a_{S1} .

d_S0	d_S63
A-field (64 symbols)	
a_S0	a_S63

Figure 6.8: A-field in the D-field

A D-field name is associated to each modulation configuration as shown in table 6.5.

Table 6.5: D-field mapping for the physical packet P00

Short slot P00					
Configuration	D-field name	D-field (bits)	A-field (bits)	B-field (bits)	X-field (bits)
1a	D00a	64	64	-	-
1b	D00b	64	64	-	-
2	D00	64	64	-	-
2b	D00	64	64	-	-
3	D00	64	64	-	-
3b	D00	64	64	-	-
4a	D00a	128	128	-	-
4b	D00b	192	192	-	-
5	D00	64	64	-	-
6	D00	64	64	-	-

6.2.1.1.4 D-field mapping for the variable slot structure (physical packet P00j)

The D-field mapping of the physical packet P00j is shown in figure 6.9. The A-field contains 64 symbols numbered from a_{S0} to a_{S63} , the B-field contains j symbols numbered from b_{S0} to b_{Sj-1} and the X-field contains 4 symbols numbered from x_{S0} to x_{S3} . The symbol a_{S0} occurs earlier than the symbol a_{S1} .

With $j = 80$ the guard space is the same for half slots as for full slots (see EN 300 175-2 [2]). The ability to set j provides flexibility for future low rate speech codec applications.

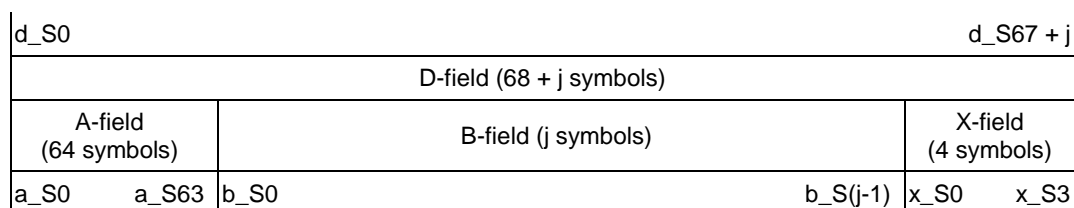

Figure 6.9: A-field, B-field and X-field in the D-field

D-field name is associated to each modulation configuration as shown in table 6.6.

Table 6.6: D-field mapping for the physical packet P00j

Half slot P00j (j=80)					
Configuration	D-field name	D-field (bits)	A-field (bits)	B-field (bits)	X-field (bits)
1a	D08a	148	64	80	4
1b	D08b	148	64	80	4
2	D16	232	64	160	8
2b (see note)	D16/D08b	232/148	64	160/80	8/4
3	D24	316	64	240	12
3b (see note)	D24/D16	316/232	64	240/160	12/8
4a	D16a	296	128	160	8
4b	D24b	444	192	240	12
5	D32	400	64	320	16
6	D48	568	64	480	24

NOTE: In this configuration the first D-field mapping is used when the E/U mux is in U-type mode and the second D-field mapping is used when the E/U mux is in E or E+U type modes.

Long slot P00j (j=640)					
Configuration	D-field name	D-field (bits)	A-field (bits)	B-field (bits)	X-field (bits)
1a	D64a	708	64	640	4
1b	D64b	708	64	640	4
2	D128	1 352	64	1 280	8
2b (see note)	D128/D64b	1 352/708	64	1 280/640	8/4
3	D192	1 996	64	1 920	12
3b (see note)	D192	1 996/1 352	64	1 920/1 280	12/4
4a	D128a	1 416	128	1 280	8
4b	D192b	2 124	192	1 920	12
5	D256	2 640	64	2 560	16
6	D384	3 928	64	3 840	24

NOTE: In this configuration the first D-field mapping is used when the E/U mux is in U-type mode and the second D-field mapping is used when the E/U mux is in E or E+U type modes.

Long slot P00j (j=672)					
Configuration	D-field name	D-field (bits)	A-field (bits)	B-field (bits)	X-field (bits)
1a	D67a	740	64	672	4
1b	D67b	740	64	672	4
2	D134	1 416	64	1 344	8
2b (see note)	D134/D67b	1 416/740	64	1 344/672	8/4
3	D201	2 092	64	2 016	12
3b (see note)	D201/D134	2 092/1 416	64	2 016/1 344	12/8
4a	D134a	1 480	128	1 344	8
4b	D201b	2 220	192	2 016	12
5	D268	2 768	64	2 688	16
6	D403	4 120	64	4 032	24

NOTE: In this configuration the first D-field mapping is used when the E/U mux is in U-type mode and the second D-field mapping is used when the E/U mux is in E or E+U type modes.

6.2.1.2 A-field Mapping (A-MAP)

The division of the A-field into Header (H), Tail (T), and Redundancy (RA) bits, is shown in figure 6.10.

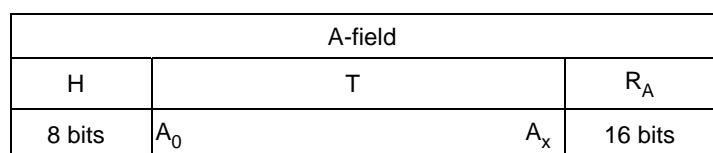

Figure 6.10: A-field mapping

A D-field name is associated to each modulation configuration as shown in table 6.7.

Table 6.7: A-field mapping

Configuration	D-field name	A-field (bits)
1a	D00a	64
1b	D00b	64
2	D00	64
2b	D00	64
3	D00	64
3b	D00	64
4a	D00a	128
4b	D00b	192
5	D00	64
6	D00	64

The header, H, is located in bits a₀ to a₇ and contains the 8 bit MAC layer permanent control data field.

The tail T, varies in function of the modulation level.

The remaining 16 bits are redundancy bits, R_A , to provide error control on all the A-field data. See clause 6.2.5.2 for the calculation of the value of these bits.

NOTE: The format and content of the 4a and 4b types A-field for the bits succeeding the currently standardized H and T fields of the A-field (see figure 6.10) is not specified at the moment and left for further standardization.

By definition the header field always contains the MAC control information.

The tail carries data from several logical channels, using the T-MUX algorithm defined in clause 6.2.2.1.

6.2.1.3 B-field Mapping (B-MAP)

For the B-field four mappings exist, an unprotected format, an encoded protected format, a protected format with multiple subfields and a protected format with one subfield.

6.2.1.3.1 Unprotected format

The B-field mapping is shown in figure 6.11. The bits of the B-field are numbered from b_0 to b_x where b_0 occurs earlier than b_1 .

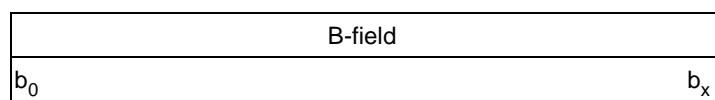

Figure 6.11: B-field structure of the Unprotected format

6.2.1.3.1.1 B-field mapping for the double slot structure (physical packet P80)

A D-field name is associated to each modulation configuration as shown in table 6.8.

Table 6.8: B-field mapping for the physical packet P80

Double slot P80		
Configuration	D-field name	B-field (bits)
1a	D80a	800
1b	D80b	800
2	D160	1 600
2b	D160	1 600
3	D240	2 400
3b	D240	2 400
4a	D160a	1 600
4b	D240b	2 400
5	D320	3 200
6	D480	4 800

NOTE: In unprotected format, there is no need to consider differences when configuration 2b and 3b are used because when the E/U mux switches to E mode, the format is always the multi-subfield (as clause 6.2.1.3.3). This note also applies to tables 6.19 and 6.10.

6.2.1.3.1.2 B-field mapping for the full slot structure (physical packet P32)

A D-field name is associated to each modulation configuration as shown in table 6.9.

Table 6.9: B-field mapping for the physical packet P32

Full slot P32		
Configuration	D-field name	B-field (bits)
1a	D32a	320
1b	D32b	320
2	D64	640
2b	D64	640
3	D96	960
3b	D96	960
4a	D64a	640
4b	D96b	960
5	D128	1 280
6	D192	1 920

6.2.1.3.1.3 B-field mapping for the half and long slot structure (physical packet P00j)

A D-field name is associated to each modulation configuration as shown in table 6.10.

Table 6.10: B-field mapping for the physical packet P00j

Half slot P00j (j=80)		
Configuration	D-field name	B-field (bits)
1a	D08a	80
1b	D08b	80
2	D16	160
2b	D16	160
3	D24	240
3b	D24	240
4a	D16a	160
4b	D24b	240
5	D32	320
6	D48	480

Long slot P00j (j=640)		
Configuration	D-field name	B-field (bits)
1a	D64a	640
1b	D64b	640
2	D128	1 280
2b	D128	1 280
3	D192	1 920
3b	D192	1 920
4a	D128a	1 280
4b	D192b	1 920
5	D256	2 560
6	D384	3 840

Long slot P00j (j=672)		
Configuration	D-field name	B-field (bits)
1a	D67a	672
1b	D67b	672
2	D134	1 344
2b	D134	1 344
3	D201	2 016
3b	D201	2 016
4a	D134a	1 344
4b	D201b	2 016
5	D268	2 688
6	D403	4 032

6.2.1.3.2 Encoded protected format

The I_p information can be protected by using channel coding followed with interleaving as described in annex I.

The channel coding followed with interleaving applies the same B-field mapping as the Unprotected format. Tables 6.8 to 6.10 define the number of B-field bits after the encoding process.

The encoding process differentiates between useful bits and parity bits. The data rates of useful bits are defined in annex I.

6.2.1.3.3 Multisubfield protected format

The multisubfield protected format divides the B-field into subfields of 80 bit length. The subfields are numbered B_0 to B_x where B_0 occurs earlier than B_1 . The bits of each subfield are numbered from b_0 to b_x where b_0 occurs earlier than b_1 .

All 80 bit subfields consist of a 64 bit data block followed by 16 CRC bits (RBj-fields). In all multisubfield protected formats the 80 bit subfield B_0 is placed in the same relative position to the synchronization word.

The B-field mapping is shown in figure 6.12. The bits of the B-field are numbered from b_0 to b_x where b_0 occurs earlier than b_1 .

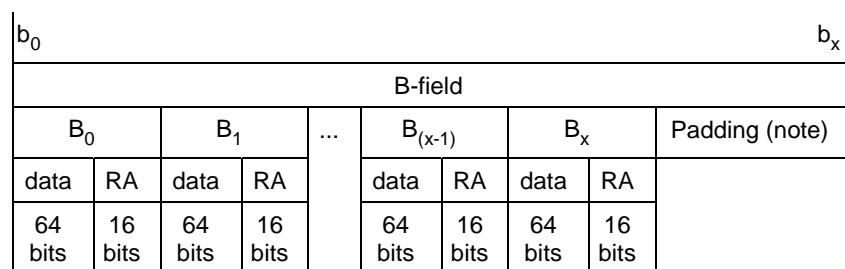

Figure 6.12: B-field structure of the Multisubfield protected format

NOTE: Padding bits are necessary for long slot with $j=672$. In all other cases there will be no padding bits.

- Padding = 32 bits for long slot ($j=672$) with 2-level modulation.
- Padding = 64 bits for long slot ($j=672$) with 4-level modulation.
- Padding = 96 bits for long slot ($j=672$) with 8-level modulation.
- Padding = 128 bits for long slot ($j=672$) with 16-level modulation.
- Padding = 192 bits for long slot ($j=672$) with 64-level modulation.

The padding field (numbered from p_0 to p_x where p_0 occurs earlier than p_1) shall be filled as follows.

p_0	$p_x=b_x$
Padding-field	
00001111 00001111	... 00001111

Figure 6.12a: Padding field (only for long slot $j=672$)

6.2.1.3.3.1 B-field mapping for the double slot structure (physical packet P80)

A D-field name is associated to each modulation configuration as shown in table 6.11.

Table 6.11: B-field mapping for the physical packet P80

Double slot P80			
Configuration	D-field name	B-field (bits)	number of B-subfields
1a	D80a	800	10
1b	D80b	800	10
2	D160	1 600	20
2b (see note)	D160/D80b	1 600/800	20/10
3	D240	2 400	30
3b (see note)	D240/D160	2 400/1600	30/20
4a	D160a	1 600	20
4b	D240b	2 400	30
5	D320	3 200	40
6	D480	4 800	60
NOTE: In configurations 2b and 3b, the first D-field mapping is used when the E/U mux is in U-type mode and the second D-field mapping is used when the E/U mux switches to E or E+U type modes.			

6.2.1.3.3.2 B-field mapping for the full slot structure (physical packet P32)

A D-field name is associated to each modulation configuration as shown in table 6.12.

Table 6.12: B-field mapping for the physical packet P32

Full slot P32			
Configuration	D-field name	B-field (bits)	number of B-subfields
1a	D32a	320	4
1b	D32b	320	4
2	D64	640	8
2b (see note)	D64/D32b	640/320	8/4
3	D96	960	12
3b (see note)	D96/D64	960/640	12/8
4a	D64a	640	8
4b	D96b	960	12
5	D128	1 280	16
6	D192	1 920	24
NOTE: In configurations 2b and 3b, the first D-field mapping is used when the E/U mux is in U-type mode and the second D-field mapping is used when the E/U mux switches to E or E+U type modes.			

6.2.1.3.3.3 B-field mapping for the half and long slot structure (physical packet P00j)

A D-field name is associated to each modulation configuration as shown in table 6.13.

Table 6.13: B-field mapping for the physical packet P00j

Half slot P00j (j=80)			
Configuration	D-field name	B-field (bits)	number of B-subfields
1a	D08a	80	1
1b	D08b	80	1
2	D16	160	2
2b (see note)	D16/D08b	160/80	2/1
3	D24	240	3
3b (see note)	D24/D16	240/160	3/3
4a	D16a	160	2
4b	D24b	240	3
5	D32	320	4
6	D48	480	6

NOTE: In configurations 2b and 3b, the first D-field mapping is used when the E/U mux is in U-type mode and the second D-field mapping is used when the E/U mux switches to E or E+U type modes.

Long slot P00j (j=640)			
Configuration	D-field name	B-field (bits)	number of B-subfields
1a	D64a	640	8
1b	D64b	640	8
2	D128	1 280	16
2b (see note)	D128/D64b	1 280/649	16/8
3	D192	1 920	24
3b (see note)	D192/D128	1 920/1 280	24/16
4a	D128a	1 280	16
4b	D192b	1 920	24
5	D256	2 560	32
6	D384	3 840	48

NOTE: In configurations 2b and 3b, the first D-field mapping is used when the E/U mux is in U-type mode and the second D-field mapping is used when the E/U mux switches to E or E+U type modes.

Half slot P00j (j=672)			
Configuration	D-field name	B-field (bits)	number of B-subfields
1a	D67a	672	8
1b	D67b	672	8
2	D134	1 344	16
2b (see note)	D134/D67b	1 344/672	16/8
3	D201	2 016	24
3b (see note)	D201/D134	2 016/1 344	24/16
4a	D134a	1 344	16
4b	D201b	2 016	24
5	D268	2 688	32
6	D403	4 032	48

NOTE: In configurations 2b and 3b, the first D-field mapping is used when the E/U mux is in U-type mode and the second D-field mapping is used when the E/U mux switches to E or E+U type modes.

6.2.1.3.4 Singlesubfield protected format switches

The B-field mapping is shown in figure 6.13. The bits of the B-field are numbered from b_0 to b_x where b_0 occurs earlier than b_1 . The singlesubfield protected format uses the B-field for one subfield numbered B_0 . This single subfield consists of one data block of various length depending on the modulation type and slot format used. This single subfield is protected by one CRC field RB0.

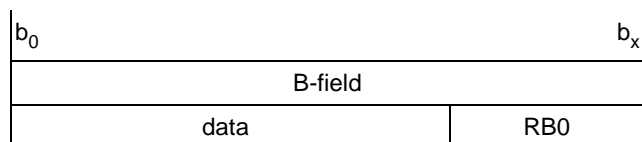

Figure 6.13: B-field structure of the Singlesubfield protected format

6.2.1.3.4.1 B-field mapping for the double slot structure (physical packet P80)

A D-field name is associated to each modulation configuration as shown in table 6.14.

Table 6.14: B-field mapping for the physical packet P80

Double slot P80			
Configuration	D-field name	data (bits)	RB0 (bits)
1a	D80a	768	32
1b	D80b	768	32
2	D160	1 568	32
2b	D160	1 568	32
3	D240	2 368	32
3b	D240	2 368	32
4a	D160a	1 568	32
4b	D240b	2 368	32
5	D320	3 168	32
6	D480	4 768	32

NOTE: In configuration 2b and 3b, when the E/U mux switches to E or E+U type modes, the format changes to multisubfield format, second D-field mapping, with the parameters shown in table 6.11.

6.2.1.3.4.2 B-field mapping for the full slot structure (physical packet P32)

A D-field name is associated to each modulation configuration as shown in table 6.15.

Table 6.15: B-field mapping for the physical packet P32

Full slot P32			
Configuration	D-field name	data (bits)	RB0 (bits)
1a	D32a	304	16
1b	D32b	304	16
2	D64	608	32
2b	D64	608	32
3	D96	928	32
3b	D96	928	32
4a	D64a	608	32
4b	D96b	928	32
5	D128	1 248	32
6	D192	1 888	32

NOTE: In configuration 2b and 3b, when the E/U mux switches to E or E+U type modes, the format changes to multisubfield format, second D-field mapping, with the parameters shown in table 6.12.

6.2.1.3.4.3 B-field mapping for the half and long slot structure (physical packet P00j)

The singlesubfield protected format shall not be allowed with $j=80$.

A D-field name is associated to each modulation configuration as shown in table 6.16.

Table 6.16: B-field mapping for the physical packet P00j

Long slot P00j (j=640)			
Configuration	D-field name	data (bits)	RB0 (bits)
1a	D64a	608	32
1b	D64b	608	32
2	D128	1 248	32
2b	D128	1 248	32
3	D192	1 888	32
3b	D192	1 888	32
4a	D128a	1 248	32
4b	D192b	1 888	32
5	D256	2 528	32
6	D384	3 808	32

Long slot P00j (j=672)			
Configuration	D-field name	data (bits)	RB0 (bits)
1a	D67a	640	32
1b	D67b	640	32
2	D134	1 312	32
2b	D134	1 312	32
3	D201	1 984	32
3b	D201	1 984	32
4a	D134a	1 312	32
4b	D201b	1 984	32
5	D268	2 656	32
6	D403	4 000	32

NOTE: In configuration 2b and 3b, when the E/U mux switches to E or E+U type modes, the format changes to multisubfield format, second D-field mapping, with the parameters shown in table 6.13.

6.2.1.3.5 Constant-size subfield protected format

The constant-size subfield protected format is defined as identical to the single-subfield protected format for 2-level modulation. For higher level modulation, the format replicates the structure of the 2-level case, n times, being n the number of bits per symbol of the modulation.

The size of each data segment and the size of the CRC field are always constant irrespective of the modulation size, and identical to the single-subfield format case for 2-level modulation.

For 2-level modulation, the B-field mapping is shown in figure 6.13a. This bit mapping and the CRC generation schema are identical to the single-subfield format case for 2-level modulation.

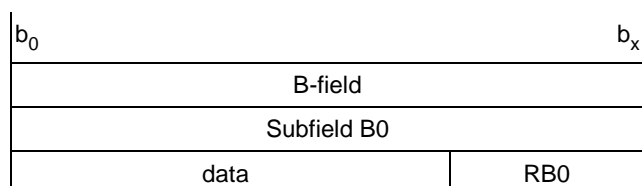

Figure 6.13a: B-field structure of the constant-size subfield protected format for 2-level modulation

For 4-level modulation, the B-field mapping is shown in figure 6.13a. The bits of the B-field are numbered from b_0 to b_x where b_0 occurs earlier than b_1 . The B-field is divided in two subfields numbered B0 and B1. Each subfield uses the structure of the defined in figure 6.13a. Therefore there are two data segments and two CRC fields in the positions shown in figure 6.13b.

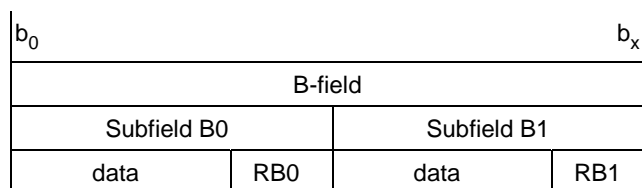

Figure 6.13b: B-field structure of the constant-size subfield protected format for 4-level modulation

For 8-level modulation, the B-field mapping is shown in figure 6.13c. The bits of the B-field are numbered from b_0 to b_x where b_0 occurs earlier than b_1 . The B-field is divided in three subfields numbered B0 and B1. Each subfield uses the structure of the defined in figure 6.13a. Therefore there are three data segments and two CRC fields in the positions shown in figure 6.13b.

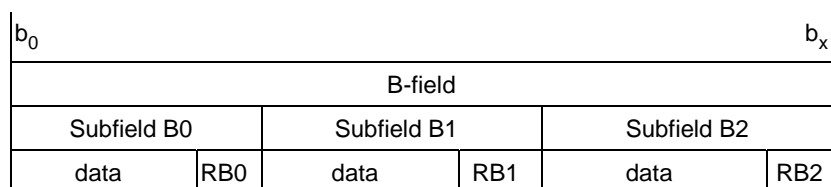

Figure 6.13c: B-field structure of the constant-size subfield protected format for 8-level modulation

For any other modulation level, the B-field mapping is shown in figure 6.13d. The number of subfields will be 4 for 16QAM and 6 for 64QAM.

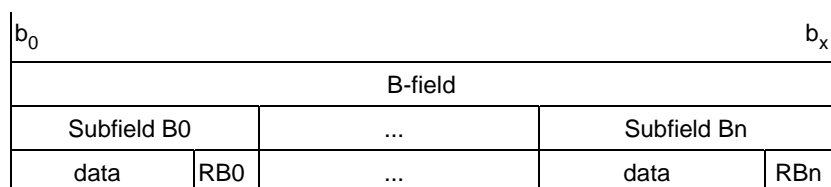

Figure 6.13d: B-field structure of the constant-size subfield protected format for any other higher level modulation

6.2.1.3.5.1 B-field mapping for the double slot structure (physical packet P80)

A D-field name is associated to each modulation configuration as shown in table 6.16a.

Table 6.16a: B-field mapping for the physical packet P80

Double slot P80			
Configuration	D-field name	data (bits)	RBx (bits)
1a	D80a	768	32
1b	D80b	768	32
2	D160	1 536 (2 x 768)	64 (2 x 32)
2b	D160	1 536 (2 x 768)	64 (2 x 32)
3	D240	2 304 (3 x 768)	96 (3 x 32)
3b	D240	2 304 (3 x 768)	96 (3 x 32)
4a	D160a	1 536 (2 x 768)	64 (2 x 32)
4b	D240b	2 304 (3 x 768)	96 (3 x 32)
5	D320	3 072 (4 x 768)	128 (4 x 32)
6	D480	4 608 (6 x 768)	192 (6 x 32)

NOTE: In configuration 2b and 3b, when the E/U mux switches to E or E+U type modes, the format changes to multisubfield format, second D-field mapping, with the parameters shown in table 6.11.

6.2.1.3.5.2 B-field mapping for the full slot structure (physical packet P32)

A D-field name is associated to each modulation configuration as shown in table 6.16b.

Table 6.16b: B-field mapping for the physical packet P32

Full slot P32			
Configuration	D-field name	data (bits)	RBx (bits)
1a	D32a	304	16
1b	D32b	304	16
2	D64	608 (2 x 304)	32 (2 x 16)
3	D96	912 (3 x 304)	48 (3 x 16)
4a	D64a	608 (2 x 304)	32 (2 x 16)
4b	D96b	912 (3 x 304)	48 (3 x 16)
5	D128	1 216 (4 x 304)	64 (4 x 16)
6	D192	1 824 (6 x 304)	96 (6 x 16)

NOTE: In configuration 2b and 3b, when the E/U mux switches to E or E+U type modes, the format changes to multisubfield format, second D-field mapping, with the parameters shown in table 6.12.

6.2.1.3.5.3 B-field mapping for the half and long slot structure (physical packet P00j)

The constant-size-subfield protected format shall not be allowed with $j=80$.

A D-field name is associated to each modulation configuration as shown in table 6.16c.

Table 6.16c: B-field mapping for the physical packet P00j

Long slot P00j (j=640)			
Configuration	D-field name	data (bits)	RBx (bits)
1a	D64a	608	32
1b	D64b	608	32
2	D128	1 216 (2 x 608)	64 (2 x 32)
3	D192	1 824 (3 x 608)	96 (3 x 32)
4a	D128a	1 216 (2 x 608)	64 (2 x 32)
4b	D192b	1 824 (3 x 608)	96 (3 x 32)
5	D256	2 432 (4 x 608)	128 (4 x 32)
6	D384	3 648 (6 x 608)	192 (6 x 32)

Long slot P00j (j=672)			
Configuration	D-field name	data (bits)	RB0 (bits)
1a	D67a	640	32
1b	D67b	640	32
2	D134	1 280 (2 x 640)	64 (2 x 32)
3	D201	1 920 (3 x 640)	96 (3 x 32)
4a	D134a	1 280 (2 x 640)	64 (2 x 32)
4b	D201b	1 920 (3 x 640)	96 (3 x 32)
5	D268	2 560 (4 x 640)	128 (4 x 32)
6	D403	3 840 (6 x 640)	192 (6 x 32)

NOTE: In configuration 2b and 3b, when the E/U mux switches to E or E+U type modes, the format changes to multisubfield format, second D-field mapping, with the parameters shown in table 6.13.

6.2.1.3.5.4 Number of segments and interface to DLC in the constant-size-subfield protected format

When operating with any modulation higher than the 2-level, the constant-size-subfield protected format provides n segments per MAC slot to the higher layers, being n the number of subfields, equal to the number of bits per symbol of the modulation.

NOTE: Therefore, a MAC bearer transports n independent DLC PDUs.

6.2.2 Time multiplexers

A T-MUX (tail-multiplex) changes the tail T, which can be one of the tail types, P_T , Q_T , N_T , C_T and M_T . A E/U-MUX selects between E-type and U-type. The C-MUX controls the mode of the B-field, distributing the flow of MAC control information, M, G_F , C_F , and CL_F data into the B-field.

T-MUX algorithms are different for RFPs and PTs because PTs do not transmit P and Q channels. C-MUX and E/U-MUX algorithms are the same for both equipments.

6.2.2.1 Tail MULTiplexer (T-MUX)

The tail, T, contains 40 bits. The logical channels carried in the tail depend upon the tail type. This is detailed in table 6.17.

Table 6.17: T-MUX

C_T	one C_S or CL_S channel segment
M_T	one M channel message
N_T	one N channel message
P_T	one P channel message (see clauses 7.2.4 and 9.1.3)
Q_T	one Q channel message
NOTE: These tail types are multiplexed on a frame-by-frame basis.	

6.2.2.1.1 T-MUX algorithm for RFP transmissions

The DECT RFPs support a multiframe structure of 16 frames duration. Both frame and multiframe timing shall be synchronized for all RFPs of one DECT FP.

The 16 frames in one multiframe are numbered from frame 0 to frame 15. Once every multiframe, a special tail identification is sent in the header, H, to mark frame number 8 of the multiframe.

In all odd frames the tail contains either M_T , C_T or N_T . The applied " M_T , C_T , N_T " priority scheme means:

- M_T type tails have priority over;
- C_T type tails which have priority over;
- N_T type tails.

In frames {0,2,4,6,10,12} a " P_T , N_T " priority scheme is used:

- P_T type tails have priority over the N_T type tails.

The tail of frame 14 is reserved for N_T (" N_T " priority scheme) and the tail of frame 8 is reserved for Q_T information (" Q_T " scheme).

The resulting algorithm is given in table 6.18.

Table 6.18: T-MUX algorithm

Frame	Priority scheme	Frame	Priority scheme
0	P _T , N _T	1	M _T , C _T , N _T
2	P _T , N _T	3	M _T , C _T , N _T
4	P _T , N _T	5	M _T , C _T , N _T
6	P _T , N _T	7	M _T , C _T , N _T
8	Q _T	9	M _T , C _T , N _T
10	P _T , N _T	11	M _T , C _T , N _T
12	P _T , N _T	13	M _T , C _T , N _T
14	N _T	15	M _T , C _T , N _T

- Exceptions:
- 1) When responding to a "bearer request" message or during bearer release, the FT may insert an MT tail in an even numbered frame.
 - 2) When responding to a "Expedited Access Request" or "Expedited Access Request Ready for Release" the response message "Bearer Confirm" have the highest priority and may be inserted in an even numbered frame.
 - 3) The M_T messages "expedited access request", "Expedited Access Request Ready for Release", "Ready for Release" and "Expedited Release" of the Advanced Connection Control part 2 set (see clause 7.2.5.12.1), have always the highest priority and may be placed in any frame
 - 4) The M_T message "Null or G_{FA} channel transmission" of the Advanced Connection Control part 2 set (see clause 7.2.5.12.4), when the OP code is "G_{FA} channel transmission" has the standard M_T priority.
 - 5) The M_T message "Null or G_{FA} channel transmission" of the Advanced Connection Control part 2 set (see clause 7.2.5.12.4), when the OP code is "Null" has lower priority than C_T.

The following throughput capacities are achieved:

(fpmf = frames per multiframe):

C _T :	higher layer control	0 kbit/s to 2 kbit/s	0 fpmf to 8 fpmf;
M _T :	MAC layer control	0 kbit/s to 2 kbit/s	0 fpmf to 8 fpmf;
N _T :	identities information	0,25 kbit/s to 3,75 kbit/s	1 fpmf to 15 fpmf;
	lower limit, excluding exceptions as above	0,25 kbit/s	1 fpmf;
P _T :	paging	0 kbit/s to 1,5 kbit/s	0 fpmf to 6 fpmf;
Q _T :	system information, excluding exceptions as above	0,25 kbit/s	1 fpmf.

Reply to a request for a BMC service (non continuous broadcast) always starts with an M_T message (see clause 7.2.5.6) which may be placed in any frame. For reply to a request for a BMC service a second transmission may occur in the next TDMA frame. This second transmission uses an M_T tail.

6.2.2.1.2 T-MUX algorithm for PT transmissions

The algorithm shown in table 6.19 is used by PTs for all traffic bearers in connection oriented services.

Table 6.19: T-MUX algorithm for PT transmissions

Frame	Priority scheme	Frame	Priority scheme
0	M _T , C _T , N _T	1	N _T
2	M _T , C _T , N _T	3	N _T
4	M _T , C _T , N _T	5	N _T
6	M _T , C _T , N _T	7	N _T
8	M _T , C _T , N _T	9	N _T
10	M _T , C _T , N _T	11	N _T
12	M _T , C _T , N _T	13	N _T
14	M _T , C _T , N _T	15	N _T

- Exceptions:
- 1) The transmission of a "bearer request" or a "bearer release" from a PT uses an M_T tail and this may be placed in any frame (see clauses 10.5 and 10.7).
 - 2) The M_T messages "expedited access request", "Expedited Access Request Ready for Release", "ready for release" and "expedited release" of the Advanced Connection Control part 2 set (see clause 7.2.5.12.1), have the highest priority and may be placed in any frame
 - 3) The M_T message "Null or G_{FA} channel transmission" of the Advanced Connection Control part 2 set (see clause 7.2.5.12.4), when the OP code is "G_{FA} channel transmission" has the standard M_T priority.
 - 4) The M_T message "Null or G_{FA} channel transmission" of the Advanced Connection Control part 2 set (see clause 7.2.5.12.4), when the OP code is "Null" has lower priority than C_T.

The following throughput capacities are achieved:

(fpmf = frames per multi-frame):

C _T :	higher layer control	0 kbit/s to 2 kbit/s	0 fpmf to 8 fpmf;
M _T :	MAC layer control	0 kbit/s to 2 kbit/s	0 fpmf to 8 fpmf;
N _T :	identities information	2 kbit/s to 4 kbit/s	8 fpmf to 16 fpmf;
	lower limit, excluding exceptions as above	2 kbit/s	8 fpmf.

Connectionless uplink services and requests for a BMC service (non continuous broadcast) always start with an M_T message in the first P_T transmission (see clause 7.2.5.6) which may be placed in any frame. For connectionless uplink services and requests for a BMC service a second transmission may occur in the next TDMA frame. This second transmission uses a C_T tail when a CL_S segment is carried and an M_T tail otherwise.

6.2.2.2 B-field control multiplexer (E/U-MUX)

The E/U MUX switches the B-field between two types of multiplex, the E-type, the U-type and the E+U type.

1) **E-type:**

- for traffic bearers the B-field is used to carry M channel data and/or C_F channel data and/or G_F channel data. For connectionless bearers the B-field is used to carry M channel data and/or CL_F channel data.

2) **U-type:**

- the B-field is used to carry either I_N channel data or I_P channel data, or SI_N or SI_P channel data.

3) **E+U-type:**

- the B-field is used to carry M channel data and/or G_F channel data and protected U plane data. The U-plane channel transported by this format is named I_{PF} channel. For connectionless bearers the B-field carries M channel data and SI_{PF} channel data.

NOTE: The I_{PF} channel incorporates a segmentation mechanism in order to transport I_P packets (I_{PM} or I_{PQ} size) by the variable capacity I_{PF} channel (see clause 10.8.4 for description of the I_{PF} channel operation).

The E/U MUX operates on a slot-by-slot basis in response to immediate traffic demands. The chosen multiplex for each frame is indicated with the BA bits in the A-field header. E-type or E+U type multiplexers have priority over U-type multiplex.

The B-field multiplexes are defined in tables 6.20 to 6.22.

Table 6.20: B-field multiplexes (2-level)

B-field multiplex for 2-level modulation					E/U	B-field format	Logical channel/ MAC service
D80-field	D64-field	D67-field	D32-field	D08-field			
E80	E64	E67	E32	(see note 2)	E+U	Multisubfield protected	E+U type MUX (M or G_F or I_{PF} or SI_{PF})
E80	E64	E67	E32	E08	E	Multisubfield protected	E-type MUX (M or G_F or C_F)
U80a	U64a	U67a	U32a	U08a	U	Unprotected	I_{NA} , I_{NB} , or SI_N
U80b	U64b	U67b	U32b	U08b	U	Multisubfield protected	I_{PM} , I_{PMR} , or SI_P
U80c	U64c	U67c	U32c		U	Singlesubfield protected	I_{PQ} , or I_{PQR}
U80d	U64d	U67d	U32d		U	Constant-size subfield protected	I_{PK} , or I_{PKR}
U80e	U64e	-	U32e	U08d	U	Encoded protected (see note 1)	I_{PX}

NOTE 1: The Encoded protected format is defined in annex I.
NOTE 2: E+U mode is not possible in slot type D08.

Table 6.21: B-field multiplexes (4-level)

B-field multiplex for 4-level modulation					E/U	B-field format	Logical channel
D160-field	D128-field	D134-field	D64-field	D16-field			
E160	E128	E134	E64	E16	E+U	Multisubfield protected	E+U-type MUX (M or G_F or I_{PF} or SI_{PF})
E160	E128	E134	E64	E16	E	Multisubfield protected	E-type MUX (M or G_F or C_F)
U160a	U128a	U134a	U64a	U16a	U	Unprotected	I_{NA} , I_{NB} , or SI_N
U160b	U128b	U134b	U64b	U16b	U	Multisubfield protected	I_{PM} , I_{PMR} , or SI_P
U160c	U128c	U134c	U64c		U	Singlesubfield protected	I_{PQ} , or I_{PQR}
U160d	U128d	U134d	U64d		U	Constant-size subfield protected	I_{PK} , or I_{PKR}
U160e	U128e	-	U64e	U16e	U	Encoded protected (see note)	I_{PX}

NOTE: The Encoded protected format is defined in annex I.

Table 6.22: B-field multiplexes (8-level)

B-field multiplex for 8-level modulation					E/U	B-field format	Logical channel
D240-field	D192-field	D201-field	D96-field	D24-field			
E240	E192	E201	E96	E24	E	Multisubfield protected Unprotected	C-MUX I_{NA} , I_{NB} , or S_{IN}
U240a	U192a	U201a	U96a	U24a	U		
U240b	U192b	U201b	U96b	U24b	U	Multisubfield protected	I_{PM} , I_{PMR} , or S_{IP}
U240c	U192c	U201c	U96c	U24c	U	Singlesubfield protected	I_{PQ} , or I_{PQR}
U240d	U192d	U201d	U96d		U	Constant-size subfield protected	I_{PK} , or I_{PKR}
U240e	U192e	-	U96e	U24e	U	Encoded protected (see note)	I_{PX}

NOTE: The Encoded protected format is defined in annex I.

Table 6.22a: B-field multiplexes (16-level)

B-field multiplex for 16-level modulation					E/U	B-field format	Logical channel
D320-field	D256-field	D268-field	D128-field	D32-field			
E320	E256	E268	E128	E32	E	Multisubfield protected	C-MUX
U320e	U256e	-	U128e	U32e	U	Encoded protected (see note)	I_{PX}

NOTE: The Encoded protected format is defined in annex I.

Table 6.22b: B-field multiplexes (64-level)

B-field multiplex for 64-level modulation					E/U	B-field format	Logical channel
D480-field	D384-field	D403-field	D192-field	D48-field			
E480	E384	E403	E192	E48	E	Multisubfield protected	C-MUX
U480e	U384e	-	U192e	U48e	U	Encoded protected (see note)	I_{PX}

NOTE: The Encoded protected format is defined in annex I.

The E-type and E+U type multiplexers always use the multisubfield protected B-field format. The possible modes of the E-type and E+U type multiplexers are defined in clause 6.2.2.3.

The U-type multiplex in connection oriented services may use either: the single-subfield protected B-field format, the multi-subfield protected B-field format, or the unprotected B-field format. This choice is defined at connection establishment for all bearers belonging to that connection, and it corresponds to the logical channel required for the chosen service, I_{PQ} , I_{PK} , I_{PM} or I_{N} . The chosen format is maintained until it is re-negotiated or the connection ends.

6.2.2.3 B-field mode multiplexer E-type and E+U-type modes

6.2.2.3.1 E-type and E+U-type modes for slots with more than one subfield

This clause applies to all cases except half slot with 2-level modulation.

6.2.2.3.1.1 Slot modes with more than one subfield: E-type mux mode

For double slot, long slot ($j=640$ or $j=672$), full slot and half slot modes, in case of 4-level, 8-level, 16-level and 64-level modulation all B-subfields are used for control. The following types of information have to be multiplexed:

- higher layer control from the C_F or CL_F logical channel;
- MAC layer connection related signalling;

- higher layer information from the G_F logical channel; and
- MAC layer control to describe the contents of the subfields.

All extended MAC control and G_F segments carried in the B-subfields have a header with a bit indicating if the next subfield in the same databurst contains an extended MAC control or G_F segment, or whether it contains higher layer control.

6.2.2.3.1.2 Slot modes with more than one subfield: E+U type mux mode

For double slot, long slot ($j=640$ or $j=672$), full slot and half slot modes, in case of 2-level and 4-level modulation, the B-subfields are used for control or for transporting I_{PF} channel U-plane data.

The following types of information have to be multiplexed:

- MAC layer connection related signalling;
- higher layer information from the G_F logical channel;
- MAC layer control to describe the contents of the subfields;
- U-plane data (channels I_{PF} and SI_{PF}); and
- MAC layer control to describe the segmentation of channels I_{PF} and SI_{PF} .

The following rules shall be fulfilled:

- At least the first subfield shall carry M channel signalling.
- Subfields transporting signalling shall precede subfields carrying I_{PF} channel data.
- The number of subfields carrying I_{PF} channel data is variable from 1 to N-1 subfields, being N the number of subfields.
- No C_F channel signalling can be transported by E+U type mux slots.
- If there are not enough signalling messages plus I_{PF} channel segments to fill the slot, the slot shall be filled with the MAC message "NULL" (clause 7.3.3) repeated as many times as needed and placed after the valid signalling subfields and before the I_{PF} channel segments.
- All extended MAC control and G_F segments carried in the B-subfields have a header with a bit indicating if the next subfield in the same slot contains an M channel message (extended MAC control) or G_F segment, or whether it contains U-plane data (channels I_{PF} and SI_{PF}).

6.2.2.3.1.3 Double slot modes

For D80 double slot operation (2-level modulation) the modes are given in table 6.23.

Table 6.23: D80 double slot 2-level modes

		Subfield	B0	B1	B2	B3	B4	B5	B6	B7	B8	B9	
E type mux	*1	Mode 0	C/O	C _F	C _F	C _F	C _F	C _F	C _F	C _F	C _F	C _F	C _F
			C/L	CL _F	CL _F	CL _F	CL _F	CL _F	CL _F	CL _F	CL _F	CL _F	CL _F
	Mode 1	C/O	M/M+G _F	C _F	C _F	C _F	C _F	C _F	C _F	C _F	C _F	C _F	C _F
		C/L	M	CL _F	CL _F	CL _F	CL _F	CL _F	CL _F	CL _F	CL _F	CL _F	CL _F
	Mode 2	C/O	M/M+G _F	M/M+G _F	C _F	C _F	C _F	C _F	C _F	C _F	C _F	C _F	C _F
		C/L	M	M	CL _F	CL _F	CL _F	CL _F	CL _F	CL _F	CL _F	CL _F	CL _F
	Mode 3	C/O	M/M+G _F	M/M+G _F	M/M+G _F	C _F	C _F	C _F	C _F	C _F	C _F	C _F	C _F
		C/L	M	M	M	CL _F	CL _F	CL _F	CL _F	CL _F	CL _F	CL _F	CL _F
	Mode 4	C/O	M/M+G _F	M/M+G _F	M/M+G _F	M/M+G _F	C _F	C _F	C _F	C _F	C _F	C _F	C _F
		C/L	M	M	M	M	CL _F	CL _F	CL _F	CL _F	CL _F	CL _F	CL _F
	Mode 5	C/O	M/M+G _F	M/M+G _F	M/M+G _F	M/M+G _F	M/M+G _F	C _F	C _F	C _F	C _F	C _F	C _F
		C/L	M	M	M	M	M	CL _F	CL _F	CL _F	CL _F	CL _F	CL _F
	Mode 6	C/O	M/M+G _F	M/M+G _F	M/M+G _F	M/M+G _F	M/M+G _F	M/M+G _F	C _F	C _F	C _F	C _F	C _F
		C/L	M	M	M	M	M	M	CL _F	CL _F	CL _F	CL _F	CL _F
	Mode 7	C/O	M/M+G _F	M/M+G _F	M/M+G _F	M/M+G _F	M/M+G _F	M/M+G _F	M/M+G _F	M/M+G _F	C _F	C _F	C _F
		C/L	M	M	M	M	M	M	M	M	CL _F	CL _F	CL _F
	Mode 8	C/O	M/M+G _F	M/M+G _F	M/M+G _F	M/M+G _F	M/M+G _F	M/M+G _F	M/M+G _F	M/M+G _F	M/M+G _F	C _F	C _F
		C/L	M	M	M	M	M	M	M	M	M	CL _F	CL _F
	Mode 9	C/O	M/M+G _F	M/M+G _F	M/M+G _F	M/M+G _F	M/M+G _F	M/M+G _F	M/M+G _F	M/M+G _F	M/M+G _F	M/M+G _F	C _F
		C/L	M	M	M	M	M	M	M	M	M	M	CL _F
E+U type mux	Mode 10	C/O	M/M+G _F	M/M+G _F	M/M+G _F	M/M+G _F	M/M+G _F	M/M+G _F	M/M+G _F	M/M+G _F	M/M+G _F	M/M+G _F	M/M+G _F
		C/L	M	M	M	M	M	M	M	M	M	M	M
	Mode 11	C/O	M/M+G _F	I _{PF}	I _{PF}	I _{PF}	I _{PF}	I _{PF}	I _{PF}	I _{PF}	I _{PF}	I _{PF}	I _{PF}
		C/L	M	SI _{PF}	SI _{PF}	SI _{PF}	SI _{PF}	SI _{PF}	SI _{PF}	SI _{PF}	SI _{PF}	SI _{PF}	SI _{PF}
	Mode 12	C/O	M/M+G _F	M/M+G _F	I _{PF}	I _{PF}	I _{PF}	I _{PF}	I _{PF}	I _{PF}	I _{PF}	I _{PF}	I _{PF}
		C/L	M	M	SI _{PF}	SI _{PF}	SI _{PF}	SI _{PF}	SI _{PF}	SI _{PF}	SI _{PF}	SI _{PF}	SI _{PF}
	Mode 14	C/O	M/M+G _F	M/M+G _F	M/M+G _F	I _{PF}	I _{PF}	I _{PF}	I _{PF}	I _{PF}	I _{PF}	I _{PF}	I _{PF}
		C/L	M	M	M	SI _{PF}	SI _{PF}	SI _{PF}	SI _{PF}	SI _{PF}	SI _{PF}	SI _{PF}	SI _{PF}
	Mode 15	C/O	M/M+G _F	M/M+G _F	M/M+G _F	M/M+G _F	I _{PF}	I _{PF}	I _{PF}	I _{PF}	I _{PF}	I _{PF}	I _{PF}
		C/L	M	M	M	M	SI _{PF}	SI _{PF}	SI _{PF}	SI _{PF}	SI _{PF}	SI _{PF}	SI _{PF}
	Mode 16	C/O	M/M+G _F	M/M+G _F	M/M+G _F	M/M+G _F	M/M+G _F	I _{PF}	I _{PF}	I _{PF}	I _{PF}	I _{PF}	I _{PF}
		C/L	M	M	M	M	M	SI _{PF}	SI _{PF}	SI _{PF}	SI _{PF}	SI _{PF}	SI _{PF}
	Mode 16	C/O	M/M+G _F	M/M+G _F	M/M+G _F	M/M+G _F	M/M+G _F	M/M+G _F	I _{PF}	I _{PF}	I _{PF}	I _{PF}	I _{PF}
		C/L	M	M	M	M	M	M	SI _{PF}	SI _{PF}	SI _{PF}	SI _{PF}	SI _{PF}
	Mode 17	C/O	M/M+G _F	M/M+G _F	M/M+G _F	M/M+G _F	M/M+G _F	M/M+G _F	M/M+G _F	M/M+G _F	I _{PF}	I _{PF}	I _{PF}
		C/L	M	M	M	M	M	M	M	M	SI _{PF}	SI _{PF}	SI _{PF}
	Mode 18	C/O	M/M+G _F	M/M+G _F	M/M+G _F	M/M+G _F	M/M+G _F	M/M+G _F	M/M+G _F	M/M+G _F	M/M+G _F	I _{PF}	I _{PF}
		C/L	M	M	M	M	M	M	M	M	M	SI _{PF}	SI _{PF}
	Mode 19	C/O	M/M+G _F	M/M+G _F	M/M+G _F	M/M+G _F	M/M+G _F	M/M+G _F	M/M+G _F	M/M+G _F	M/M+G _F	M/M+G _F	I _{PF}
		C/L	M	M	M	M	M	M	M	M	M	M	SI _{PF}

*1 = E-type mux, C_F only: BA codes 010 or 011

For D80 double slot operation the A-field header coding (BA bits) shall distinguish between the following modes:

- E-type, C_F only: mode 0 (BA bits codes "010" and "011").
- E-type, M + G_F + C_F: modes 1 to 9 (BA bits codes "100" and "101").

- E type, $M + G_F$: mode 10: (BA bit code "110").
- E+U type, $M + G_F + I_{PF}$: modes 11 to 19: (BA bit codes "110" and "111").

BA bit code "111" shall only be used if regular (U-type) MAC service is IP-error-correct.

For D160 double slot operation (4-level modulation) the modes are given in table 6.24.

Table 6.24: D160 double slot 4-level modes

		Subfield	B0	B1	...	i-1	i	i + 1	...	B17	B18	B19	
	*1	Mode 0	C/O	C_F	C_F	...	C_F	C_F	C_F	...	C_F	C_F	C_F
			C/L	CL_F	CL_F	...	CL_F	CL_F	CL_F	...	CL_F	CL_F	CL_F
E type mux	BA codes 100 or 101	Mode 1	C/O	$M/M+G_F$	C_F	...	C_F	C_F	C_F	...	C_F	C_F	C_F
			C/L	M	CL_F	...	CL_F	CL_F	CL_F	...	CL_F	CL_F	CL_F
		...	C/O
		...	C/L
		Mode i	C/O	$M/M+G_F$	$M/M+G_F$...	$M/M+G_F$	C_F	C_F	...	C_F	C_F	C_F
			C/L	M	M	...	M	CL_F	CL_F	...	CL_F	CL_F	CL_F
		Mode i + 1	C/O	$M/M+G_F$	$M/M+G_F$...	$M/M+G_F$	$M/M+G_F$	C_F	...	C_F	C_F	C_F
			C/L	M	M	...	M	M	CL_F	...	CL_F	CL_F	CL_F
		...	C/O
		...	C/L
		Mode 19	C/O	$M/M+G_F$	$M/M+G_F$...	$M/M+G_F$	$M/M+G_F$	$M/M+G_F$...	$M/M+G_F$	$M/M+G_F$	C_F
			C/L	M	M	...	M	M	M	...	M	M	CL_F
E+U type mux	BA codes 110 or 111	Mode 20	C/O	$M/M+G_F$	$M/M+G_F$...	$M/M+G_F$	$M/M+G_F$	$M/M+G_F$...	$M/M+G_F$	$M/M+G_F$	$M/M+G_F$
			C/L	M	M	...	M	M	M	...	M	M	M
		Mode 21	C/O	$M/M+G_F$	I_{PF}	...	I_{PF}	I_{PF}	I_{PF}	...	I_{PF}	I_{PF}	I_{PF}
			C/L	M	SI_{PF}	...	SI_{PF}	SI_{PF}	SI_{PF}	...	SI_{PF}	SI_{PF}	SI_{PF}
		...	C/O
		...	C/L
		Mode j	C/O	$M/M+G_F$	$M/M+G_F$...	$M/M+G_F$	I_{PF}	I_{PF}	...	I_{PF}	I_{PF}	I_{PF}
			C/L	M	M	...	M	SI_{PF}	SI_{PF}	...	SI_{PF}	SI_{PF}	SI_{PF}
		Mode j + 1	C/O	$M/M+G_F$	$M/M+G_F$...	$M/M+G_F$	$M/M+G_F$	I_{PF}	...	I_{PF}	I_{PF}	I_{PF}
			C/L	M	M	...	M	M	SI_{PF}	...	SI_{PF}	SI_{PF}	SI_{PF}
		...	C/O
		...	C/L
Mode 39	C/O	$M/M+G_F$	$M/M+G_F$...	$M/M+G_F$	$M/M+G_F$	$M/M+G_F$...	$M/M+G_F$	$M/M+G_F$	I_{PF}		
	C/L	M	M	...	M	M	M	...	M	M	SI_{PF}		

For D160 double slot operation the A-field header coding (BA bits) shall distinguish between:

- E-type, C_F only: mode 0 (BA bits codes "010" and "011").
- E-type, $M + G_F + C_F$: modes 1 to 19 (BA bits codes "100" and "101").
- E type, $M + G_F$: mode 20: (BA bit code "110").
- E+U type, $M + G_F + I_{PF}$: modes 21 to 39: (BA bit codes "110" and "111").

BA bit code "111" shall only be used if regular (U-type) MAC service is IP-error-correct.

For D240 double slot operation (8-level modulation) the modes are given in table 6.25.

Table 6.25: D240 double slot 8-level modes

Subfield		B0	B1	...	i-1	i	i + 1	...	B27	B28	B29
Mode 0	C/O	C _F	C _F	...	C _F	C _F	C _F	...	C _F	C _F	C _F
	C/L	CL _F	CL _F	...	CL _F	CL _F	CL _F	...	CL _F	CL _F	CL _F
Mode 1	C/O	M/M+G _F	C _F	...	C _F	C _F	C _F	...	C _F	C _F	C _F
	C/L	M	CL _F	...	CL _F	CL _F	CL _F	...	CL _F	CL _F	CL _F
...	C/O
	C/L
Mode i	C/O	M/M+G _F	M/M+G _F	...	M/M+G _F	C _F	C _F	...	C _F	C _F	C _F
	C/L	M	M	...	M	CL _F	CL _F	...	CL _F	CL _F	CL _F
Mode i + 1	C/O	M/M+G _F	M/M+G _F	...	M/M+G _F	M/M+G _F	C _F	...	C _F	C _F	C _F
	C/L	M	M	...	M	M	CL _F	...	CL _F	CL _F	CL _F
...	C/O
	C/L
Mode 29	C/O	M/M+G _F	M/M+G _F	...	M/M+G _F	M/M+G _F	M/M+G _F	...	M/M+G _F	M/M+G _F	C _F
	C/L	M	M	...	M	M	M	...	M	M	CL _F
Mode 30	C/O	M/M+G _F	M/M+G _F	...	M/M+G _F	M/M+G _F	M/M+G _F	...	M/M+G _F	M/M+G _F	M/M+G _F
	C/L	M	M	...	M	M	M	...	M	M	M

For D240 double slot operation the A-field header coding (BA bits) shall distinguish between:

- E-type, mode 0;
- E-type, modes 1 to 29; and
- E-type, mode 30.

For D320 double slot operation (16-level modulation) the modes are given in table 6.25a.

Table 6.25a: D320 double slot 16-level modes

Subfield		B0	B1	...	i-1	i	i + 1	...	B37	B38	B39
Mode 0	C/O	C _F	C _F	...	C _F	C _F	C _F	...	C _F	C _F	C _F
	C/L	CL _F	CL _F	...	CL _F	CL _F	CL _F	...	CL _F	CL _F	CL _F
Mode 1	C/O	M/M+G _F	C _F	...	C _F	C _F	C _F	...	C _F	C _F	C _F
	C/L	M	CL _F	...	CL _F	CL _F	CL _F	...	CL _F	CL _F	CL _F
...	C/O
	C/L
Mode i	C/O	M/M+G _F	M/M+G _F	...	M/M+G _F	C _F	C _F	...	C _F	C _F	C _F
	C/L	M	M	...	M	CL _F	CL _F	...	CL _F	CL _F	CL _F
Mode i + 1	C/O	M/M+G _F	M/M+G _F	...	M/M+G _F	M/M+G _F	C _F	...	C _F	C _F	C _F
	C/L	M	M	...	M	M	CL _F	...	CL _F	CL _F	CL _F
...	C/O
	C/L
Mode 39	C/O	M/M+G _F	M/M+G _F	...	M/M+G _F	M/M+G _F	M/M+G _F	...	M/M+G _F	M/M+G _F	C _F
	C/L	M	M	...	M	M	M	...	M	M	CL _F
Mode 40	C/O	M/M+G _F	M/M+G _F	...	M/M+G _F	M/M+G _F	M/M+G _F	...	M/M+G _F	M/M+G _F	M/M+G _F
	C/L	M	M	...	M	M	M	...	M	M	M

For D320 double slot operation the A-field header coding (BA bits) shall distinguish between:

- E-type, mode 0;
- E-type, modes 1 to 39; and

- E-type, mode 40.

For D480 double slot operation (64-level modulation) the modes are given in table 6.25b.

Table 6.25b: D480 double slot 64-level modes

Subfield		B0	B1	...	i-1	i	i + 1	...	B57	B58	B59
Mode 0	C/O	C _F	C _F	...	C _F	C _F	C _F	...	C _F	C _F	C _F
	C/L	CL _F	CL _F	...	CL _F	CL _F	CL _F	...	CL _F	CL _F	CL _F
Mode 1	C/O	M/M+G _F	C _F	...	C _F	C _F	C _F	...	C _F	C _F	C _F
	C/L	M	CL _F	...	CL _F	CL _F	CL _F	...	CL _F	CL _F	CL _F
...	C/O
	C/L
Mode i	C/O	M/M+G _F	M/M+G _F	...	M/M+G _F	C _F	C _F	...	C _F	C _F	C _F
	C/L	M	M	...	M	CL _F	CL _F	...	CL _F	CL _F	CL _F
Mode i + 1	C/O	M/M+G _F	M/M+G _F	...	M/M+G _F	M/M+G _F	C _F	...	C _F	C _F	C _F
	C/L	M	M	...	M	M	CL _F	...	CL _F	CL _F	CL _F
...	C/O
	C/L
Mode 59	C/O	M/M+G _F	M/M+G _F	...	M/M+G _F	M/M+G _F	M/M+G _F	...	M/M+G _F	M/M+G _F	C _F
	C/L	M	M	...	M	M	M	...	M	M	CL _F
Mode 60	C/O	M/M+G _F	M/M+G _F	...	M/M+G _F	M/M+G _F	M/M+G _F	...	M/M+G _F	M/M+G _F	M/M+G _F
	C/L	M	M	...	M	M	M	...	M	M	M

For D480 double slot operation the A-field header coding (BA bits) shall distinguish between:

- E-type, mode 0;
- E-type, modes 1 to 59; and
- E-type, mode 60.

6.2.2.3.1.4 Full slot modes

For D32 full slot operation (2-level modulation) the modes given in table 6.26 are allowed.

Table 6.26: D32 full slot 2-level modes

	Subfield	B0	B1	B2	B3	
		C/O	C _F	C _F	C _F	C _F
E type mux	*1 Mode 0	C/L	CL _F	CL _F	CL _F	
		Mode 1	C/O	M/M+G _F	C _F	C _F
	C/L		M	CL _F	CL _F	
	Mode 2	C/O	M/M+G _F	M/M+G _F	C _F	
		C/L	M	M	CL _F	
	Mode 3	C/O	M/M+G _F	M/M+G _F	M/M+G _F	
		C/L	M	M	CL _F	
	Mode 4	C/O	M/M+G _F	M/M+G _F	M/M+G _F	
		C/L	M	M	M	
	E+U type mux	Mode 5	C/O	M/M+G _F	I _{PF}	I _{PF}
			C/L	M	SI _{PF}	SI _{PF}
		Mode 6	C/O	M/M+G _F	M/M+G _F	I _{PF}
			C/L	M	M	SI _{PF}
		Mode 7	C/O	M/M+G _F	M/M+G _F	M/M+G _F
C/L			M	M	SI _{PF}	

*1 = E-type mux, C_F only: BA codes 010 or 011

For full slot D32 operation the A-field header coding (BA bits) will distinguish between the following modes:

- E-type, C_F only: mode 0 (BA bits codes "010" and "011").
- E-type, $M + G_F + C_F$: modes 1 to 3 (BA bits codes "100" and "101").
- E type, $M + G_F$: mode 4: (BA bit code "110").
- E+U type, $M + G_F + I_{PF}$: modes 4 to 7: (BA bit codes "110" and "111").

BA bit code "111" shall only be used if regular (U-type) MAC service is IP-error-correct.

For D64 full slot operation (4-level modulation) the modes given in table 6.27 are allowed.

Table 6.27: D64 full slot 4-level modes

		Subfield		B0	B1	B2	B3	B4	B5	B6	B7	
E type mux	*1	Mode 0	C/O	C_F	C_F	C_F	C_F	C_F	C_F	C_F	C_F	
			C/L	CL_F	CL_F	CL_F	CL_F	CL_F	CL_F	CL_F	CL_F	
		BA codes 100 or 101	Mode 1	C/O	$M/M+G_F$	C_F	C_F	C_F	C_F	C_F	C_F	C_F
				C/L	M	CL_F	CL_F	CL_F	CL_F	CL_F	CL_F	CL_F
			Mode 2	C/O	$M/M+G_F$	$M/M+G_F$	C_F	C_F	C_F	C_F	C_F	C_F
				C/L	M	M	CL_F	CL_F	CL_F	CL_F	CL_F	CL_F
			Mode 3	C/O	$M/M+G_F$	$M/M+G_F$	$M/M+G_F$	C_F	C_F	C_F	C_F	C_F
				C/L	M	M	M	CL_F	CL_F	CL_F	CL_F	CL_F
			Mode 4	C/O	$M/M+G_F$	$M/M+G_F$	$M/M+G_F$	$M/M+G_F$	C_F	C_F	C_F	C_F
				C/L	M	M	M	M	CL_F	CL_F	CL_F	CL_F
			Mode 5	C/O	$M/M+G_F$	$M/M+G_F$	$M/M+G_F$	$M/M+G_F$	$M/M+G_F$	C_F	C_F	C_F
				C/L	M	M	M	M	M	CL_F	CL_F	CL_F
			Mode 6	C/O	$M/M+G_F$	$M/M+G_F$	$M/M+G_F$	$M/M+G_F$	$M/M+G_F$	$M/M+G_F$	C_F	C_F
				C/L	M	M	M	M	M	M	M	CL_F
			Mode 7	C/O	$M/M+G_F$	$M/M+G_F$	$M/M+G_F$	$M/M+G_F$	$M/M+G_F$	$M/M+G_F$	$M/M+G_F$	C_F
				C/L	M	M	M	M	M	M	M	M
E+U type mux		Mode 8	C/O	$M/M+G_F$	$M/M+G_F$	$M/M+G_F$	$M/M+G_F$	$M/M+G_F$	$M/M+G_F$	$M/M+G_F$	$M/M+G_F$	
			C/L	M	M	M	M	M	M	M	M	M
			Mode 9	C/O	$M/M+G_F$	I_{PF}	I_{PF}	I_{PF}	I_{PF}	I_{PF}	I_{PF}	I_{PF}
				C/L	M	SI_{PF}	SI_{PF}	SI_{PF}	SI_{PF}	SI_{PF}	SI_{PF}	SI_{PF}
			Mode 10	C/O	$M/M+G_F$	$M/M+G_F$	I_{PF}	I_{PF}	I_{PF}	I_{PF}	I_{PF}	I_{PF}
				C/L	M	M	SI_{PF}	SI_{PF}	SI_{PF}	SI_{PF}	SI_{PF}	SI_{PF}
			Mode 11	C/O	$M/M+G_F$	$M/M+G_F$	$M/M+G_F$	I_{PF}	I_{PF}	I_{PF}	I_{PF}	I_{PF}
				C/L	M	M	M	SI_{PF}	SI_{PF}	SI_{PF}	SI_{PF}	SI_{PF}
			Mode 12	C/O	$M/M+G_F$	$M/M+G_F$	$M/M+G_F$	$M/M+G_F$	I_{PF}	I_{PF}	I_{PF}	I_{PF}
				C/L	M	M	M	M	SI_{PF}	SI_{PF}	SI_{PF}	SI_{PF}
			Mode 13	C/O	$M/M+G_F$	$M/M+G_F$	$M/M+G_F$	$M/M+G_F$	$M/M+G_F$	I_{PF}	I_{PF}	I_{PF}
				C/L	M	M	M	M	M	SI_{PF}	SI_{PF}	SI_{PF}
			Mode 14	C/O	$M/M+G_F$	$M/M+G_F$	$M/M+G_F$	$M/M+G_F$	$M/M+G_F$	$M/M+G_F$	I_{PF}	I_{PF}
				C/L	M	M	M	M	M	M	M	SI_{PF}
			Mode 15	C/O	$M/M+G_F$	$M/M+G_F$	$M/M+G_F$	$M/M+G_F$	$M/M+G_F$	$M/M+G_F$	$M/M+G_F$	I_{PF}
				C/L	M	M	M	M	M	M	M	M

*1 = E-type mux, C_F only: BA codes 010 or 011

For D64 full slot operation the A-field header coding (BA bits) will distinguish between:

- E-type, C_F only: mode 0 (BA bits codes "010" and "011").
- E-type, $M + G_F + C_F$: modes 1 to 7 (BA bits codes "100" and "101").

- E type, $M + G_F$: mode 8: (BA bit code "110").
- E+U type, $M + G_F + I_{PF}$: modes 9 to 15: (BA bit codes "110" and "111").

BA bit code "111" shall only be used if regular (U-type) MAC service is I_P -error-correct.

For D96 full slot operation (8-level modulation) the modes are given in table 6.28.

Table 6.28: D96 full slot 8-level modes

Subfield		B0	B1	...	i-1	i	i + 1	...	B09	B10	B11
Mode 0	C/O	C_F	C_F	...	C_F	C_F	C_F	...	C_F	C_F	C_F
	C/L	CL_F	CL_F	...	CL_F	CL_F	CL_F	...	CL_F	CL_F	CL_F
Mode 1	C/O	$M/M+G_F$	C_F	...	C_F	C_F	C_F	...	C_F	C_F	C_F
	C/L	M	CL_F	...	CL_F	CL_F	CL_F	...	CL_F	CL_F	CL_F
...	C/O
	C/L
Mode i	C/O	$M/M+G_F$	$M/M+G_F$...	$M/M+G_F$	C_F	C_F	...	C_F	C_F	C_F
	C/L	M	M	...	M	CL_F	CL_F	...	CL_F	CL_F	CL_F
Mode i + 1	C/O	$M/M+G_F$	$M/M+G_F$...	$M/M+G_F$	$M/M+G_F$	C_F	...	C_F	C_F	C_F
	C/L	M	M	...	M	M	CL_F	...	CL_F	CL_F	CL_F
...	C/O
	C/L
Mode 11	C/O	$M/M+G_F$	$M/M+G_F$...	$M/M+G_F$	$M/M+G_F$	$M/M+G_F$...	$M/M+G_F$	$M/M+G_F$	C_F
	C/L	M	M	...	M	M	M	...	M	M	CL_F
Mode 12	C/O	$M/M+G_F$	$M/M+G_F$...	$M/M+G_F$	$M/M+G_F$	$M/M+G_F$...	$M/M+G_F$	$M/M+G_F$	$M/M+G_F$
	C/L	M	M	...	M	M	M	...	M	M	M

For D96 full slot operation the A-field header coding (BA bits) shall distinguish between:

- E-type, mode 0;
- E-type, modes 1 to 11; and
- E-type, mode 12.

For D128 full slot operation (16-level modulation) the modes are given in table 6.28a.

Table 6.28a: D128 full slot 16-level modes

Subfield		B0	B1	...	i-1	i	i + 1	...	B13	B14	B15
Mode 0	C/O	C_F	C_F	...	C_F	C_F	C_F	...	C_F	C_F	C_F
	C/L	CL_F	CL_F	...	CL_F	CL_F	CL_F	...	CL_F	CL_F	CL_F
Mode 1	C/O	$M/M+G_F$	C_F	...	C_F	C_F	C_F	...	C_F	C_F	C_F
	C/L	M	CL_F	...	CL_F	CL_F	CL_F	...	CL_F	CL_F	CL_F
...	C/O
	C/L
Mode i	C/O	$M/M+G_F$	$M/M+G_F$...	$M/M+G_F$	C_F	C_F	...	C_F	C_F	C_F
	C/L	M	M	...	M	CL_F	CL_F	...	CL_F	CL_F	CL_F
Mode i + 1	C/O	$M/M+G_F$	$M/M+G_F$...	$M/M+G_F$	$M/M+G_F$	C_F	...	C_F	C_F	C_F
	C/L	M	M	...	M	M	CL_F	...	CL_F	CL_F	CL_F
...	C/O
	C/L
Mode 15	C/O	$M/M+G_F$	$M/M+G_F$...	$M/M+G_F$	$M/M+G_F$	$M/M+G_F$...	$M/M+G_F$	$M/M+G_F$	C_F
	C/L	M	M	...	M	M	M	...	M	M	CL_F
Mode 16	C/O	$M/M+G_F$	$M/M+G_F$...	$M/M+G_F$	$M/M+G_F$	$M/M+G_F$...	$M/M+G_F$	$M/M+G_F$	$M/M+G_F$
	C/L	M	M	...	M	M	M	...	M	M	M

For D128 full slot operation the A-field header coding (BA bits) shall distinguish between:

- E-type, mode 0;
- E-type, modes 1 to 15; and
- E-type, mode 16.

For D192 full slot operation (64-level modulation) the modes are given in table 6.28b.

Table 6.28b: D192 full slot 64-level modes

Subfield		B0	B1	...	i-1	i	i + 1	...	B21	B22	B23
Mode 0	C/O	C _F	C _F	...	C _F	C _F	C _F	...	C _F	C _F	C _F
	C/L	CL _F	CL _F	...	CL _F	CL _F	CL _F	...	CL _F	CL _F	CL _F
Mode 1	C/O	M/M+G _F	C _F	...	C _F	C _F	C _F	...	C _F	C _F	C _F
	C/L	M	CL _F	...	CL _F	CL _F	CL _F	...	CL _F	CL _F	CL _F
...	C/O
	C/L
Mode i	C/O	M/M+G _F	M/M+G _F	...	M/M+G _F	C _F	C _F	...	C _F	C _F	C _F
	C/L	M	M	...	M	CL _F	CL _F	...	CL _F	CL _F	CL _F
Mode i + 1	C/O	M/M+G _F	M/M+G _F	...	M/M+G _F	M/M+G _F	C _F	...	C _F	C _F	C _F
	C/L	M	M	...	M	M	CL _F	...	CL _F	CL _F	CL _F
...	C/O
	C/L
Mode 23	C/O	M/M+G _F	M/M+G _F	...	M/M+G _F	M/M+G _F	M/M+G _F	...	M/M+G _F	M/M+G _F	C _F
	C/L	M	M	...	M	M	M	...	M	M	CL _F
Mode 24	C/O	M/M+G _F	M/M+G _F	...	M/M+G _F	M/M+G _F	M/M+G _F	...	M/M+G _F	M/M+G _F	M/M+G _F
	C/L	M	M	...	M	M	M	...	M	M	M

For D192 full slot operation the A-field header coding (BA bits) shall distinguish between:

- E-type, mode 0;
- E-type, modes 1 to 23; and
- E-type, mode 24.

6.2.2.3.1.5 Half slot (j=80) modes

For D16 half slot operation with j=80 (4-level modulation) the modes given in table 6.29 are allowed.

Table 6.29: D16 half slot (j=80) 4-level modes

Subfield		B0	B1
Mode 0	C/O	C _F	C _F
	C/L	CL _F	CL _F
Mode 1	C/O	M/M+G _F	C _F
	C/L	M	CL _F
Mode 2	C/O	M/M+G _F	M/M+G _F
	C/L	M	M

For D16 half slot operation (j=80) the A-field header coding (BA bits) will distinguish between:

- E-type, mode 0;
- E-type, modes 1; and
- E-type, mode 2.

For D24 half slot operation ($j=80$) (8-level modulation) the modes given in table 6.30 are allowed.

Table 6.30: D-24 half slot ($j=80$) 8-level modes

Subfield		B0	B1	B2
Mode 0	C/O	C_F	C_F	C_F
	C/L	CL_F	CL_F	CL_F
Mode 1	C/O	$M/M+G_F$	C_F	C_F
	C/L	M	CL_F	CL_F
Mode 2	C/O	$M/M+G_F$	$M/M+G_F$	C_F
	C/L	M	M	CL_F
Mode 3	C/O	$M/M+G_F$	$M/M+G_F$	$M/M+G_F$
	C/L	M	M	M

For D24 half slot operation ($j=80$) the A-field header coding (BA bits) will distinguish between:

- E-type, mode 0;
- E-type, modes 1 to 2; and
- E-type, mode 3.

For D32 half slot operation ($j=80$) (16-level modulation) the modes given in table 6.31 are allowed.

Table 6.31: D-32 half slot ($j=80$) 16-level modes

Subfield		B0	B1	B2	B3
Mode 0	C/O	C_F	C_F	C_F	C_F
	C/L	CL_F	CL_F	CL_F	CL_F
Mode 1	C/O	$M/M+G_F$	C_F	C_F	C_F
	C/L	M	CL_F	CL_F	CL_F
Mode 2	C/O	$M/M+G_F$	$M/M+G_F$	C_F	C_F
	C/L	M	M	CL_F	CL_F
Mode 3	C/O	$M/M+G_F$	$M/M+G_F$	$M/M+G_F$	C_F
	C/L	M	M	M	CL_F
Mode 4	C/O	$M/M+G_F$	$M/M+G_F$	$M/M+G_F$	$M/M+G_F$
	C/L	M	M	M	M

For D32 half slot operation ($j=80$) the A-field header coding (BA bits) will distinguish between:

- E-type, mode 0;
- E-type, modes 1 to 3; and
- E-type, mode 4.

For D48 half slot operation ($j=80$) (64-level modulation) the modes given in table 6.32 are allowed.

Table 6.32: D-48 half slot ($j=80$) 64-level modes

Subfield		B0	B1	B2	B3	B4	B5
Mode 0	C/O	C_F	C_F	C_F	C_F	C_F	C_F
	C/L	CL_F	CL_F	CL_F	CL_F	CL_F	CL_F
Mode 1	C/O	$M/M+G_F$	C_F	C_F	C_F	C_F	C_F
	C/L	M	CL_F	CL_F	CL_F	CL_F	CL_F
Mode 2	C/O	$M/M+G_F$	$M/M+G_F$	C_F	C_F	C_F	C_F
			M	CL_F	CL_F	CL_F	CL_F
Mode 3	C/O	$M/M+G_F$	$M/M+G_F$	$M/M+G_F$	C_F	C_F	C_F
	C/L	M	M	M	CL_F	CL_F	CL_F
Mode 4	C/O	$M/M+G_F$	$M/M+G_F$	$M/M+G_F$	$M/M+G_F$	C_F	C_F
	C/L	M	M	M	M	CL_F	CL_F
Mode 5	C/O	$M/M+G_F$	$M/M+G_F$	$M/M+G_F$	$M/M+G_F$	$M/M+G_F$	C_F
	C/L	M	M	M	M	M	CL_F
Mode 6	C/O	$M/M+G_F$	$M/M+G_F$	$M/M+G_F$	$M/M+G_F$	$M/M+G_F$	$M/M+G_F$
	C/L	M	M	M	M	M	M

For D48 half slot operation ($j=80$) the A-field header coding (BA bits) will distinguish between:

- E-type, mode 0;
- E-type, modes 1 to 2; and
- E-type, mode 3.

6.2.2.3.1.6 Long slot (j=640 or j=672) modes

For D64/D67 long slot operation with j=640/672 (2-level modulation) the modes are given in table 6.33.

Table 6.33: D64/D67 long slot (j=640/672) 2-level modes

		Subfield	B0	B1	B2	B3	B4	B5	B6	B7	
E type mux	*1	Mode 0	C/O	C _F	C _F	C _F	C _F	C _F	C _F	C _F	C _F
			C/L	CL _F	CL _F	CL _F	CL _F	CL _F	CL _F	CL _F	CL _F
		Mode 1	C/O	M/M+G _F	C _F	C _F	C _F	C _F	C _F	C _F	C _F
			C/L	M	CL _F	CL _F	CL _F	CL _F	CL _F	CL _F	CL _F
		Mode 2	C/O	M/M+G _F	M/M+G _F	C _F	C _F	C _F	C _F	C _F	C _F
			C/L	M	M	CL _F	CL _F	CL _F	CL _F	CL _F	CL _F
		Mode 3	C/O	M/M+G _F	M/M+G _F	M/M+G _F	C _F	C _F	C _F	C _F	C _F
			C/L	M	M	M	CL _F	CL _F	CL _F	CL _F	CL _F
		Mode 4	C/O	M/M+G _F	M/M+G _F	M/M+G _F	M/M+G _F	C _F	C _F	C _F	C _F
			C/L	M	M	M	M	CL _F	CL _F	CL _F	CL _F
		Mode 5	C/O	M/M+G _F	M/M+G _F	M/M+G _F	M/M+G _F	M/M+G _F	C _F	C _F	C _F
			C/L	M	M	M	M	M	CL _F	CL _F	CL _F
		Mode 6	C/O	M/M+G _F	M/M+G _F	M/M+G _F	M/M+G _F	M/M+G _F	M/M+G _F	C _F	C _F
			C/L	M	M	M	M	M	M	CL _F	CL _F
		Mode 7	C/O	M/M+G _F	M/M+G _F	M/M+G _F	M/M+G _F	M/M+G _F	M/M+G _F	M/M+G _F	C _F
C/L			M	M	M	M	M	M	M	CL _F	CL _F
E+U type mux		Mode 8	C/O	M/M+G _F	M/M+G _F	M/M+G _F	M/M+G _F	M/M+G _F	M/M+G _F	M/M+G _F	M/M+G _F
			C/L	M	M	M	M	M	M	M	M
		Mode 9	C/O	M/M+G _F	I _{PF}	I _{PF}	I _{PF}	I _{PF}	I _{PF}	I _{PF}	I _{PF}
			C/L	M	SI _{PF}	SI _{PF}	SI _{PF}	SI _{PF}	SI _{PF}	SI _{PF}	SI _{PF}
		Mode 10	C/O	M/M+G _F	M/M+G _F	I _{PF}	I _{PF}	I _{PF}	I _{PF}	I _{PF}	I _{PF}
			C/L	M	M	SI _{PF}	SI _{PF}	SI _{PF}	SI _{PF}	SI _{PF}	SI _{PF}
		Mode 11	C/O	M/M+G _F	M/M+G _F	M/M+G _F	I _{PF}	I _{PF}	I _{PF}	I _{PF}	I _{PF}
			C/L	M	M	M	SI _{PF}	SI _{PF}	SI _{PF}	SI _{PF}	SI _{PF}
		Mode 12	C/O	M/M+G _F	M/M+G _F	M/M+G _F	M/M+G _F	I _{PF}	I _{PF}	I _{PF}	I _{PF}
			C/L	M	M	M	M	SI _{PF}	SI _{PF}	SI _{PF}	SI _{PF}
		Mode 13	C/O	M/M+G _F	M/M+G _F	M/M+G _F	M/M+G _F	M/M+G _F	I _{PF}	I _{PF}	I _{PF}
			C/L	M	M	M	M	M	SI _{PF}	SI _{PF}	SI _{PF}
		Mode 14	C/O	M/M+G _F	M/M+G _F	M/M+G _F	M/M+G _F	M/M+G _F	M/M+G _F	I _{PF}	I _{PF}
			C/L	M	M	M	M	M	M	SI _{PF}	SI _{PF}
		Mode 15	C/O	M/M+G _F	M/M+G _F	M/M+G _F	M/M+G _F	M/M+G _F	M/M+G _F	M/M+G _F	I _{PF}
C/L			M	M	M	M	M	M	M	SI _{PF}	SI _{PF}

*1 = E-type mux, C_F only: BA codes 010 or 011

For D64/D67 long slot operation with j=640/672 the A-field header coding (BA bits) shall distinguish between the following modes:

- E-type, C_F only: mode 0 (BA bits codes "010" and "011").
- E-type, M + G_F + C_F: modes 1 to 7 (BA bits codes "100" and "101").
- E type, M + G_F: mode 8: (BA bit code "110").
- E+U type, M + G_F + I_{PF}: modes 9 to 15: (BA bit codes "110" and "111").

BA bit code "111" shall only be used if regular (U-type) MAC service is I_P-error-correct.

For D128/D134 long slot operation ($j=640/672$) (4-level modulation) the modes are given in the table 6.34.

Table 6.34: D128/D134 long slot ($j=640/672$) 4-level modes

		Subfield	B0	B1	...	i-1	i	i + 1	...	B13	B14	B15	
E type mux	*1	Mode 0	C/O	C_F	C_F	...	C_F	C_F	C_F	...	C_F	C_F	C_F
			C/L	CL_F	CL_F	...	CL_F	CL_F	CL_F	...	CL_F	CL_F	CL_F
		Mode 1	C/O	$M/M+G_F$	C_F	...	C_F	C_F	C_F	...	C_F	C_F	C_F
			C/L	M	CL_F	...	CL_F	CL_F	CL_F	...	CL_F	CL_F	CL_F
		...	C/O
			C/L
		Mode i	C/O	$M/M+G_F$	$M/M+G_F$...	$M/M+G_F$	C_F	C_F	...	C_F	C_F	C_F
			C/L	M	M	...	M	CL_F	CL_F	...	CL_F	CL_F	CL_F
		Mode i + 1	C/O	$M/M+G_F$	$M/M+G_F$...	$M/M+G_F$	$M/M+G_F$	C_F	...	C_F	C_F	C_F
			C/L	M	M	...	M	M	CL_F	...	CL_F	CL_F	CL_F
		...	C/O
			C/L
		Mode 15	C/O	$M/M+G_F$	$M/M+G_F$...	$M/M+G_F$	$M/M+G_F$	$M/M+G_F$...	$M/M+G_F$	$M/M+G_F$	C_F
			C/L	M	M	...	M	M	M	...	M	M	CL_F
		Mode 16	C/O	$M/M+G_F$	$M/M+G_F$...	$M/M+G_F$	$M/M+G_F$	$M/M+G_F$...	$M/M+G_F$	$M/M+G_F$	$M/M+G_F$
			C/L	M	M	...	M	M	M	...	M	M	M
Mode 17	C/O	$M/M+G_F$	I_{PF}	...	I_{PF}	I_{PF}	I_{PF}	...	I_{PF}	I_{PF}	I_{PF}		
	C/L	M	SI_{PF}	...	SI_{PF}	SI_{PF}	SI_{PF}	...	SI_{PF}	SI_{PF}	SI_{PF}		
...	C/O		
	C/L		
Mode j	C/O	$M/M+G_F$	$M/M+G_F$...	$M/M+G_F$	I_{PF}	I_{PF}	...	I_{PF}	I_{PF}	I_{PF}		
	C/L	M	M	...	M	SI_{PF}	SI_{PF}	...	SI_{PF}	SI_{PF}	SI_{PF}		
Mode j + 1	C/O	$M/M+G_F$	$M/M+G_F$...	$M/M+G_F$	$M/M+G_F$	I_{PF}	...	I_{PF}	I_{PF}	I_{PF}		
	C/L	M	M	...	M	M	SI_{PF}	...	SI_{PF}	SI_{PF}	SI_{PF}		
...	C/O		
	C/L		
Mode 31	C/O	$M/M+G_F$	$M/M+G_F$...	$M/M+G_F$	$M/M+G_F$	$M/M+G_F$...	$M/M+G_F$	$M/M+G_F$	I_{PF}		
	C/L	M	M	...	M	M	M	...	M	M	SI_{PF}		

*1 = E-type mux, C_F only: BA codes 010 or 011

For D128/D134 long slot operation ($j=640/672$) the A-field header coding (BA bits) shall distinguish between:

- E-type, C_F only: mode 0 (BA bits codes "010" and "011").
- E-type, $M + G_F + C_F$: modes 1 to 15 (BA bits codes "100" and "101").
- E type, $M + G_F$: mode 16: (BA bit code "110").
- E+U type, $M + G_F + I_{PF}$: modes 17 to 31: (BA bit codes "110" and "111").

BA bit code "111" shall only be used if regular (U-type) MAC service is I_P -error-correct.

For D192/D201 long slot operation ($j=640/672$) (8-level modulation) the modes are given in table 6.35.

Table 6.35: D192/D201 long slot ($j=640/672$) 8-level modes

Subfield		B0	B1	...	i-1	i	i + 1	...	B21	B22	B23
Mode 0	C/O	C _F	C _F	...	C _F	C _F	C _F	...	C _F	C _F	C _F
	C/L	CL _F	CL _F	...	CL _F	CL _F	CL _F	...	CL _F	CL _F	CL _F
Mode 1	C/O	M/M+G _F	C _F	...	C _F	C _F	C _F	...	C _F	C _F	C _F
	C/L	M	CL _F	...	CL _F	CL _F	CL _F	...	CL _F	CL _F	CL _F
...	C/O
	C/L
Mode i	C/O	M/M+G _F	M/M+G _F	...	M/M+G _F	C _F	C _F	...	C _F	C _F	C _F
	C/L	M	M	...	M	CL _F	CL _F	...	CL _F	CL _F	CL _F
Mode i + 1	C/O	M/M+G _F	M/M+G _F	...	M/M+G _F	M/M+G _F	C _F	...	C _F	C _F	C _F
	C/L	M	M	...	M	M	CL _F	...	CL _F	CL _F	CL _F
...	C/O
	C/L
Mode 23	C/O	M/M+G _F	M/M+G _F	...	M/M+G _F	M/M+G _F	M/M+G _F	...	M/M+G _F	M/M+G _F	C _F
	C/L	M	M	...	M	M	M	...	M	M	CL _F
Mode 24	C/O	M/M+G _F	M/M+G _F	...	M/M+G _F	M/M+G _F	M/M+G _F	...	M/M+G _F	M/M+G _F	M/M+G _F
	C/L	M	M	...	M	M	M	...	M	M	M

For D192/D201 long slot operation ($j=640/672$) the A-field header coding (BA bits) shall distinguish between:

- E-type, mode 0;
- E-type, modes 1 to 29; and
- E-type, mode 30.

For D256/D268 long slot operation ($j=640/672$) (16-level modulation) the modes are given in table 6.36.

Table 6.36: D256/D268 long slot ($j=640/672$) 16-level modes

Subfield		B0	B1	...	i-1	i	i + 1	...	B29	B30	B31
Mode 0	C/O	C _F	C _F	...	C _F	C _F	C _F	...	C _F	C _F	C _F
	C/L	CL _F	CL _F	...	CL _F	CL _F	CL _F	...	CL _F	CL _F	CL _F
Mode 1	C/O	M/M+G _F	C _F	...	C _F	C _F	C _F	...	C _F	C _F	C _F
	C/L	M	CL _F	...	CL _F	CL _F	CL _F	...	CL _F	CL _F	CL _F
...	C/O
	C/L
Mode i	C/O	M/M+G _F	M/M+G _F	...	M/M+G _F	C _F	C _F	...	C _F	C _F	C _F
	C/L	M	M	...	M	CL _F	CL _F	...	CL _F	CL _F	CL _F
Mode i + 1	C/O	M/M+G _F	M/M+G _F	...	M/M+G _F	M/M+G _F	C _F	...	C _F	C _F	C _F
	C/L	M	M	...	M	M	CL _F	...	CL _F	CL _F	CL _F
...	C/O
	C/L
Mode 31	C/O	M/M+G _F	M/M+G _F	...	M/M+G _F	M/M+G _F	M/M+G _F	...	M/M+G _F	M/M+G _F	C _F
	C/L	M	M	...	M	M	M	...	M	M	CL _F
Mode 32	C/O	M/M+G _F	M/M+G _F	...	M/M+G _F	M/M+G _F	M/M+G _F	...	M/M+G _F	M/M+G _F	M/M+G _F
	C/L	M	M	...	M	M	M	...	M	M	M

For D256/D268 long slot operation ($j=640/672$) the A-field header coding (BA bits) shall distinguish between:

- E-type, mode 0;
- E-type, modes 1 to 39; and

- E-type, mode 40.

For D384/D403 long slot operation ($j=640/672$) (64-level modulation) the modes are given in table 6.37.

Table 6.37: D384/D403 long slot ($j=640/672$) 64-level modes

Subfield		B0	B1	...	i-1	i	i + 1	...	B45	B46	B47
Mode 0	C/O	C_F	C_F	...	C_F	C_F	C_F	...	C_F	C_F	C_F
	C/L	CL_F	CL_F	...	CL_F	CL_F	CL_F	...	CL_F	CL_F	CL_F
Mode 1	C/O	M/M+ G_F	C_F	...	C_F	C_F	C_F	...	C_F	C_F	C_F
	C/L	M	CL_F	...	CL_F	CL_F	CL_F	...	CL_F	CL_F	CL_F
...	C/O
	C/L
Mode i	C/O	M/M+ G_F	M/M+ G_F	...	M/M+ G_F	C_F	C_F	...	C_F	C_F	C_F
	C/L	M	M	...	M	CL_F	CL_F	...	CL_F	CL_F	CL_F
Mode i + 1	C/O	M/M+ G_F	M/M+ G_F	...	M/M+ G_F	M/M+ G_F	C_F	...	C_F	C_F	C_F
	C/L	M	M	...	M	M	CL_F	...	CL_F	CL_F	CL_F
...	C/O
	C/L
Mode 47	C/O	M/M+ G_F	M/M+ G_F	...	M/M+ G_F	M/M+ G_F	M/M+ G_F	...	M/M+ G_F	M/M+ G_F	C_F
	C/L	M	M	...	M	M	M	...	M	M	CL_F
Mode 48	C/O	M/M+ G_F	M/M+ G_F	...	M/M+ G_F	M/M+ G_F	M/M+ G_F	...	M/M+ G_F	M/M+ G_F	M/M+ G_F
	C/L	M	M	...	M	M	M	...	M	M	M

For D384/D403 long slot operation ($j=640/672$) the A-field header coding (BA bits) shall distinguish between:

- E-type, mode 0;
- E-type, modes 1 to 59; and
- E-type, mode 60.

6.2.2.3.2 Half slot ($j=80$) modes for 2-level modulation

For D08 half slot ($j=80$) mode (2-level modulation) only one B-subfield is available for control. The following types of information have to be multiplexed:

- higher layer control from the C_F or CL_F logical channel;
- higher layer information from G_F logical channel; and
- MAC layer connection related signalling.

Only one E-type mapping exists.

The A-field header coding will distinguish between:

- E-type, mode 0; and
- E-type, mode 1.

Mode 0: the E-type databurst carries C_F or CL_F control;

Mode 1: the E-type databurst carries extended MAC or G_F control.

NOTE: E+U type mode is not applicable to half slot ($j=80$) with 2-level modulation.

6.2.2.4 Priority scheme in E or E+U mode

For Connection Oriented services (C/O) and when E/U mux is in E or E+U mode, the following priority scheme shall be used to fill the B-subfields:

- 1) **Release:** bearer release messages for this bearer may be transmitted and may be placed in all subfields.
- 2) **Bearer quality control in an asymmetric connection in subfield B₀:** in an asymmetric connection a "Bearer quality in an asymmetric connection" message (see clause 7.3.4.4), if used, shall be placed at least in the subfield B₀.
- 3) **Other MAC layer control (excluding Null message):** these messages may be placed in the remaining subfields. The subfields are used in the following order of preference, B₀, B₁, B₂, B₃, B₄, B₅, B₆, B₇, B₈, B₉.
- 4) **Retransmissions of C_F:** for retransmissions of B-fields containing C_F, the same mode shall be used (note 1).
- 5) **New C_F data:** any remaining subfields may be used for C_F data. The subfields are used in the following order of preference, B_N, B_{N-1}, ..., B₁, B₀. However, the sequence of data through the MC SAP shall be B₀, B₁, ..., B_{N-1}, B_N (note 1).
- 6) **G_F data:** this may be placed in any subfield that has not yet been used. The order of usage of subfields and the sequence of data segments through the MC SAP is not specified (note 2).
- 7) **Remaining I_{PF} packets of partially transmitted PDUs and NULL message carrying segmentation info if needed** (notes 3, 4 and 7).

If there is no channel with priority 1 to 7 to be transmitted in the slot, THEN, the E/U-mux shall go to **U-type mux mode**. The priorities 8 and 9 only apply if the E-mux is set because one or more channels with priority 1 to 7 are present.

- 8) I_{PF} packets carrying the first part of a PDU and NULL message carrying segmentation info if needed (notes 3, 4, 5 and 7).
- 9) Null message: this shall be used to fill any subfields still empty (note 6).

In connectionless services new CL_F segments have priority over MAC control.

NOTE 1: This only applies to E-type mux mode. Incompatible with channel I_{PF}.

NOTE 2: In some LU services (LU10), it is possible to avoid the use of the G_F channel by using other mechanism for transmitting the acknowledgement information. It is advisable to do that, when there is no other reason for using E-mux mode multiplexing.

NOTE 3: A G_F of a NULL message should be always in the same slot as I_{PF} data. In some cases, a NULL message is mandatory.

NOTE 4: This only applies to E+U-type mux mode. Incompatible with C_F channel.

NOTE 5: ONLY if there is other reason for setting the E/U mux in E or E+U mode. Otherwise the E/U-mux should go to U mode.

NOTE 6: It applies to the filling of remaining subfields. If there is no other channel for multiplexing, then the E/U-mux should go to U-mux mode.

NOTE 7: Items 7 and 8 are not applicable to half slot (D08) and 2-level modulation.

6.2.3 MAC Encryption

MAC Encryption is a privacy mechanism which may be provided to encrypt all C, I, and G_F channel data of a connection oriented call. The key stream generator KSG in the MBC produces the encryption sequence which is XORed with the original data in the TBC's encryption entity.

NOTE 1: When MAC encryption is enabled, C_F channel, G_F channel, I_{PF} channel and M channel data transmitted in the B-field are encrypted.

NOTE 2: However, note that there may be frames carrying any of the previous channels (or even I channel), in which the encryption is not enabled. This is the case, f.i., of the first transmitted bearers during a setup procedure, when the encryption is not enabled yet and where the "Bearer request" message is transmitted in clear. Refer to each procedure description to check when the encryption should be enabled.

NOTE 3: Error control (R-CRC, B-CRC and X-CRC bits) are never encrypted.

See EN 300 175-7 [7], clause 6.4 for details of the encryption process and for information about what specific fields and bits are encrypted, depending on the MAC service.

Before activating the encryption mechanism for the first time, the DLC provides the MBC with a secret encryption key. This key is loaded into the key stream generator KSG.

In applications where different algorithms for implementing the KSG are supported (i.e. DSC and DSC2), the DLC provides the MBC with the indication of which algorithm has to be used.

Enabling and disabling of encryption is ordered by the DLC. The MBC is responsible for switching between encryption mode and clear mode. The actual encryption mode of the connection controlled by the MBC shall be the same for all established bearers of this connection. The actual encryption mode of the connections associated with one broadband data link shall be the same for all established connections.

The present document defines:

- the messages required for switching the encryption mode of a connection;
- the primitives exchanged between MAC and DLC; and
- the instant in time to enable encryption during bearer setup provided that the new bearer belongs to a connection in encryption mode.

The following items related to the MAC layer are defined in EN 300 175-7 [7]:

- the algorithm used by the KSG to generate the encryption sequence;
- the MAC procedure to switch a connection between encryption and clear mode; and
- the mapping of the encryption sequence onto the data fields.

6.2.4 Scrambling

A scrambler is used to avoid long "0" or "1" sequences occurring several times due to unaltered data or retransmission protocols. The TBC generates pseudo-random sequences which change for consecutive TDMA frames and combines the original B-field data with these sequences.

Scrambling is applied to all B-field data except the X-field. These are:

- the first 800 bits numbered from b_0 to b_{799} for D80 double slot;
- the first 1 600 bits numbered from b_0 to $b_{1\ 599}$ for D160 double slot;
- the first 2 400 bits numbered from b_0 to $b_{2\ 399}$ for D240 double slot;
- the first 3 200 bits numbered from b_0 to $b_{3\ 199}$ for D320 double slot;

- the first 4 800 bits numbered from b_0 to $b_{4\,799}$ for D480 double slot;
- the first 320 bits numbered from b_0 to b_{319} for D32 full slot;
- the first 640 bits numbered from b_0 to b_{639} for D64 full slot;
- the first 960 bits numbered from b_0 to b_{959} for D96 full slot;
- the first 1 280 bits numbered from b_0 to $b_{1\,279}$ for D128 full slot;
- the first 1 920 bits numbered from b_0 to $b_{1\,919}$ for D192 full slot;
- the first j bits numbered from b_0 to b_j for D08 half and long slot;
- the first $2j$ bits numbered from b_0 to b_{2j} for D16 half and long slot;
- the first $3j$ bits numbered from b_0 to b_{3j} for D24 half and long slot;
- the first $4j$ bits numbered from b_0 to b_{4j} for D32 half and long slot;
- the first $6j$ bits numbered from b_0 to b_{6j} for D48 half and long slot.

The scrambled data is a combination of the original data and a scrambling sequence:

$$b_i = b_i \text{ XOR } s_{fi}$$

where:

- $i \in \{0 \dots 799\}$ for D80 double slot;
- $i \in \{0 \dots 1\,599\}$ for D160 double slot;
- $i \in \{0 \dots 2\,399\}$ for D240 double slot;
- $i \in \{0 \dots 3\,199\}$ for D320 double slot;
- $i \in \{0 \dots 4\,799\}$ for D480 double slot;
- $i \in \{0 \dots 319\}$ for D32 full slot;
- $i \in \{0 \dots 639\}$ for D64 full slot;
- $i \in \{0 \dots 959\}$ for D96 full slot;
- $i \in \{0 \dots 1\,279\}$ for D128 full slot;
- $i \in \{0 \dots 1\,919\}$ for D192 full slot;
- $i \in \{0 \dots j-1\}$ for D08 half and long slot;
- $i \in \{0 \dots 2j-1\}$ for D16 half and long slot;
- $i \in \{0 \dots 3j-1\}$ for D24 half and long slot;
- $i \in \{0 \dots 4j-1\}$ for D32 half and long slot;
- $i \in \{0 \dots 6j-1\}$ for D48 half and long slot.

XOR describes the "exclusive-OR" function and s_{fi} denotes bit "i" of the scrambling sequence s_f .

Eight scrambling sequences exist, s_0 to s_7 . The number "f" of the scrambling sequence s_f actually used, depends upon the TDMA frame number within the multi-frame structure:

$$f = (\text{TDMA frame number}) \text{ MOD } 8.$$

The scrambling sequences are based on a pseudo random sequence of length 31. This sequence is the maximal length sequence generated by the five stage shift register shown in figure 6.14.

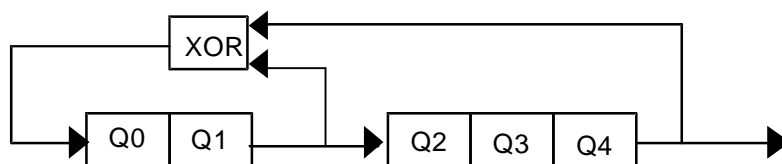

Figure 6.14: Scrambling sequence generation

For the initial state of the shift register, Q_3 and Q_4 are set to 1. Between the settings of Q_0 , Q_1 , Q_2 and the sequence number f of the scrambling sequence sf the following relation shall hold:

$$f = Q_2 \times 4 + Q_1 \times 2 + Q_0$$

The scrambling sequence corresponds to the shift register output after passing an inversion mechanism.

The output of the shift register is the actual state of Q_4 . Therefore, the first output of the shift register used to build the scrambling bit sf_0 corresponds to the initial state of Q_4 .

The inversion mechanism has two modes, the shift register output passes through non inverted or inverted. The inversion mechanism toggles from one mode to the other mode when the shift register switches to the state following the all one state. The toggle mode is preset to invert the first output of the shift register.

Scrambling of the B-field is mandatory and shall always be applied, even when encryption is active.

6.2.5 Error control

The MAC layer provides error control for all logical channels, using a combination of three Cyclic Redundancy Codes (CRC):

- R-CRC; a 16-bit CRC;
- B-CRC; a 32-bit CRC;
- X-CRC; a 4/8/12/16-bit CRC.

6.2.5.1 R-CRC overview

The R-CRC is used to provide the main MAC layer error control. The MAC layer calculates 16 redundancy bits over several fixed length data blocks:

- all A-fields;
- all B-subfields in protected format.

In each case, the redundancy bits are appended to the data blocks and allow a redundancy check in the receiver. In the different mapping schemes given in clause 6.2.1.3, the fields for transmitting the CRC bits are denoted as R_A and R_{B0} to R_{BN} . The procedure for calculating the 16 CRC bits and the rule to check a received data block with its CRC bits is defined in clause 6.2.5.2.

Data transmitted from all logical channels except the I_N channel and the SI_N channel is located in data blocks to which these 16 CRC bits are appended (see mapping schemes in clause 6.2.1). This allows the receiver to detect errors in all N, Q, B_S , C_S , C_F , CL_S , CL_F , SI_P , I_P , G_F and M channel data and in ULE enabled systems N_S , Q_C , M_U and B_U channel data.

For N, Q, B_S , CL_S , CL_F , SI_P , M and G_F channel data and, in ULE enabled systems N_S , Q_C , M_U and B_U channel data, and I_P channel data (when in the $I_P_error_detection$ service) only error detection capability is provided. No MAC layer retransmission scheme is applied for this data.

For C_S and C_F channel data, a MAC layer retransmission scheme is defined in order to correct transmission errors. A numbering scheme allows successive data transmissions on these channels to be distinguished. This allows repetition (retransmission) of the same data several times until the transmitter gets an acknowledgement from the data receiver or the transmitter stops retransmitting the data. The retransmission process is described in clause 10.8.

For the I_P _error_correction service the MAC layer provides a retransmission scheme for I_P data. Retransmissions are done for each bearer independently. The receiving side requests that the sending side transmits the last packet again until no errors are detected or, until a timer expires. When the timer expires that packet is discarded. Data passed to the upper layer is almost free from errors. This error correction scheme is called the MOD-2 retransmission scheme for I_P data, and described in clause 10.8.2.

6.2.5.2 R-CRC generation and checking

All $m = 64$ bit A-fields and all $m = 80$ bit B-subfields (see clause 6.2.1.3) contain n data bits and 16 check bits. Therefore the data block length n is $m - 16$. The 16 check bits are appended to the n data bits. For encoding, the n data bits shall be considered to be the coefficients of a polynomial having terms from x^{m-1} down to x^0 . If the m bits of one protected field are transmitted in ascending order (r_0, r_1, \dots, r_{m-1}) the polynomial is built as:

$$r_0 \times x^{m-1} + r_1 \times x^{m-2} + \dots + r_{m-1} \times x^0$$

This polynomial is divided by the generating polynomial:

$$g(x) = x^{16} + x^{10} + x^8 + x^7 + x^3 + 1 = 202\ 611 \text{ (oct)}$$

The 16 check bits shall be the coefficients of the terms from x^{15} to x^0 in the remainder polynomial, found at the completion of the division. The remainder polynomial has the form:

$$r_n \times x^{15} + r_{n+1} \times x^{14} + \dots + r_{m-1} \times x^0$$

The last check bit (coefficient r_{m-1} of the x^0 term in the remainder polynomial) is finally inverted.

In the resulting $m = n + 16$ bit codeword, the leading n bits correspond to the original data bits.

For error detecting it has to be ensured that the received m -bit codeword is a valid codeword. Again the m bits can be considered to be the coefficients of a polynomial having terms from x^{m-1} down to x^0 . If the m bits of one protected field are received in ascending order (r_0, r_1, \dots, r_{m-1}) the polynomial is built as:

$$r_0 \times x^{m-1} + r_1 \times x^{m-2} + \dots + r_{m-1} \times x^0$$

After inverting the coefficient r_{m-1} of the x^0 term the generator polynomial $g(x)$ divides all valid codewords.

6.2.5.3 X-CRC overview

For error control of B-field data a limited error detection scheme is always applied, even for unprotected B-field formats. This is the only protection that is applied to the I_N and SI_N logical channels. The MAC layer calculates 4 bits, 8 bits, 12 bits or 16 redundancy bits (depending on the level of modulation) from selected B-field data bits. These bits are transmitted in the X-field. The X-field occupies the last 4 bits, 8 bits, 12 bits, 16 bits or 24 bits of the B-field in all multiplexes. The X-field allows a redundancy check in the receiver. The procedure for calculating and checking the X-field bits is defined in clause 6.2.5.4.

In the case of the 64 QAM modulation scheme the 24 check bits of the X-field are composed of 16 redundancy bits and 8 spare bits. The 16 redundancy bits of the X-field are calculated as defined in clause 6.2.5.4. The spare bits of the X-field are set to "0000 0000".

6.2.5.4 X-CRC generation and checking

The X-field consists of the last 4 bits of the B-field for 2-level modulation, the last 8 bits of the B-field for 4-level modulation, the last 12 bits for 8-level modulation, the last 16 bits for 16-level modulation and the last 24 bits for 64-level modulation. It is used to test channel quality and to detect sliding collisions. Therefore, a CRC check is done over a selected number of scrambled B-field bits.

The overall number of test bits is m . These m bits include the 4, 8, 12 or 16 X-field bits. The number m is different for half slot, full slot, long slot and double slots and also depends on the level of modulation.

Table 6.38: Number of test bits (m)

	half slot ($j=80$)	long slot ($j=640$)	long slot ($j=672$)	Full slot	Double slot
2-level modulation	$m = 84$	$m = 164$	$m = 164$	$m = 84$	$m = 164$
4-level modulation	$m = 88$	$m = 328$	$m = 344$	$m = 168$	$m = 408$
8-level modulation	$m = 92$	$m = 492$	$m = 508$	$m = 252$	$m = 604$
16-level modulation	$m = 96$	$m = 656$	$m = 688$	$m = 336$	$m = 816$
64-level modulation	$m = 96$	$m = 976$	$m = 1\ 024$	$m = 496$	$m = 1\ 216$

With a test bit assignment of $(r_0, r_1, \dots, r_{m-1})$ the mapping of the test bits onto the B-field is the following:

For half slot ($j=80$) with 2-level modulation:

$$r_i = b_i \quad 0 \leq i \leq 3 + j$$

For half slot ($j=80$) with 4/8/16/64-level modulation:

$$r_i = b_{i+16(1+\text{INT}(i/16))} \quad 0 \leq i \leq 79$$

$$= b_{i+\Delta i} \quad 80 \leq i \leq i_{\max}$$

INT(x) is the integer part of number x , e.g. INT(12,34) = 12.

Table 6.39: Half slot parameters

	Δi	i_{\max}
4-level modulation	80	87
8-level modulation	160	91
16-level modulation	240	95
64-level modulation	400	95

For double slot with 2-level modulation:

$$r_i = b_{i+64(1+\text{INT}(i/16))} \quad 0 \leq i \leq 159$$

$$r_i = b_{i+640} \quad 160 < i \leq 163$$

For long slot ($j=640$ or $j=672$), full slot and double slot, except double slot with 2-level modulation:

$$r_i = b_{i+48(1+\text{INT}(i/16))} \quad 0 \leq i \leq i_{\max} - x$$

$$r_i = b_{i+\Delta i} \quad i_{\max} - x < i \leq i_{\max}$$

Table 6.40: Long slot, full slot and double slot parameters

	x (XCRC- Size)	long slot (j=640)		long slot (j=672)		Full slot		Double slot	
		Δi	$i_{\max = m-1}$	Δi	$i_{\max = m-1}$	Δi	$i_{\max = m-1}$	Δi	$i_{\max = m-1}$
2-level modulation	x = 4	480	163	512	163	240	83	-	-
4-level modulation	x = 8	960	327	1 008	343	480	167	1 200	407
8-level modulation	x = 12	1 440	491	1 520	507	720	251	1 808	603
16-level modulation	x = 16	1 920	655	2 016	687	960	335	2 400	815
64-level modulation	x = 16	2 880	975	3 024	1 023	1 440	495	3 600	1 215

NOTE: For double slot with 2-level modulation:
 $r_i = b_{i+64(1+\text{INT}(i/16))}$ $0 \leq i \leq 159$
 $r_i = b_{i+640}$ $160 \leq i \leq 163$.

The first $m-4$ (or $m-8$ or $m-12$ or $m-16$) bits (r_0, r_1, \dots, r_{m-5} (or $m-9$ or $m-13$ or $m-17$)) are considered as the coefficients of the polynomial:

- $r_0 \times x^{m-1} + r_1 \times x^{m-2} + \dots + r_{m-5} \times x^4$ for 2-level modulation;
- $r_0 \times x^{m-1} + r_1 \times x^{m-2} + \dots + r_{m-9} \times x^8$ for 4-level modulation;
- $r_0 \times x^{m-1} + r_1 \times x^{m-2} + \dots + r_{m-13} \times x^{12}$ for 8-level modulation;
- $r_0 \times x^{m-1} + r_1 \times x^{m-2} + \dots + r_{m-17} \times x^{16}$ for 16-level modulation and 64-level modulation.

This polynomial shall be divided by the polynomial:

- $x^4 + 1 = 21$ (oct) for 2-level modulation;
- $x^8 + 1 = 401$ (oct) for 4-level modulation;
- $x^{12} + x^{11} + x^3 + x^2 + x + 1 = 14\ 016$ (oct) for 8-level modulation;
- $x^{16} + x^{10} + x^8 + x^7 + x^3 + 1 = 202\ 611$ (oct) for 16-level modulation and 64-level modulation (This is the generating polynomial as used for the R-CRC calculation).

The remainder polynomial has the form:

- $r_{m-4} \times x^3 + r_{m-3} \times x^2 + r_{m-2} \times x + r_{m-1}$ for 2-level modulation;
- $r_{m-8} \times x^7 + r_{m-7} \times x^6 + r_{m-6} \times x^5 + r_{m-5} \times x^4 + r_{m-4} \times x^3 + r_{m-3} \times x^2 + r_{m-2} \times x^1 + r_{m-1}$ for 4-level modulation;
- $r_{m-12} \times x^{11} + r_{m-11} \times x^{10} + r_{m-10} \times x^9 + r_{m-9} \times x^8 + r_{m-8} \times x^7 + r_{m-7} \times x^6 + r_{m-6} \times x^5 + r_{m-5} \times x^4 + r_{m-4} \times x^3 + r_{m-3} \times x^2 + r_{m-2} \times x^1 + r_{m-1}$ for 8-level modulation;
- $r_{m-16} \times x^{15} + r_{m-15} \times x^{14} + r_{m-14} \times x^{13} + r_{m-13} \times x^{12} + r_{m-12} \times x^{11} + r_{m-11} \times x^{10} + r_{m-10} \times x^9 + r_{m-9} \times x^8 + r_{m-8} \times x^7 + r_{m-7} \times x^6 + r_{m-6} \times x^5 + r_{m-5} \times x^4 + r_{m-4} \times x^3 + r_{m-3} \times x^2 + r_{m-2} \times x^1 + r_{m-1}$ for 16-level modulation and 64-level modulation;

where the coefficients r_{m-4} ($m-8/m-12/m-16$) ... r_{m-1} shall represent the last four (8,12 or 16) test bits and shall be transmitted in the X-field for 2-level, 4-level, 8-level, 16-level respectively 64-level modulation.

For the X-field check, the received test pattern (r_0, r_1, \dots, r_{m-1}) builds the polynomial:

$$r_0 \times x^{m-1} + r_1 \times x^{m-2} + \dots + r_{m-1} \times x^0$$

The polynomial $x^4 + 1 = 21$ (oct), $x^8 + 1 = 401$ (oct) and $x^{12} + x^{11} + x^3 + x^2 + x + 1 = 14\ 016$ (oct) respectively $x^{16} + x^{10} + x^8 + x^7 + x^3 + 1 = 202\ 611$ (oct) divide all valid test patterns.

6.2.5.5 B-CRC generation and checking

For more efficient user data transmission I_{PQ} services using a single 32 bit CRC over the whole B-field are introduced.

All m bit I_{PQ} format B-fields, with the exception of the B-fields for packets of type P32 and D-field names D32a and D32b (see clause 6.2.1.3), contain n data bits and 32 check bits. Therefore the data block length n is $m - 32$. The 32 check bits are appended to the n data bits. For encoding, the n data bits shall be considered to be the coefficients of a polynomial having terms from x^{m-1} down to x^{32} . If the m bits of one protected field are transmitted in ascending order (r_0, r_1, \dots, r_{m-1}) the polynomial is built as:

$$d(x) = r_0 \times x^{m-1} + r_1 \times x^{m-2} + \dots + r_{n-1} \times x^{32}$$

The generator polynomial defines to:

$$g(x) = x^{32} + x^{26} + x^{23} + x^{22} + x^{16} + x^{12} + x^{11} + x^{10} + x^8 + x^7 + x^5 + x^4 + x^2 + x + 1$$

The 32 Bit checksum shall be the ones complement of the sum (modulo 2) of:

- the remainder of $x^n \times (x^{31} + x^{30} + \dots + x + 1)$ divided (modulo 2) by the generator polynomial $g(x)$;
- the remainder of the division (modulo 2) by the generator polynomial $g(x)$ of the data bit polynomial $d(x)$.

As a typical implementation at the transmitter, the initial content of the register of the device computing the remainder of the division is pre-set to all 1s and is then modified by division by the generator polynomial (as described above) on the address, control, and information fields; the ones complement of the resulting remainder is transmitted as the thirty-two-bit checksum.

As a typical implementation at the receiver, the initial content of the register of the device computing the remainder is pre-set to all 1s. The final remainder after multiplication by x^{32} and then division (modulo 2) by the generator polynomial $g(x)$ of the serial incoming protected bits and the checksum, will be "1100 0111 0000 0100 1101 1101 0111 1011" (x^{31} through x^0 , respectively) in the absence of transmission errors.

6.2.6 Broadcast controller

The broadcast controller in the TBC or CBC or DBC adds RFP specific information to data from the BMC. Some examples for RFP specific information are: the RPN number (see clause 7.2.2), the number of transceivers within the RFP, description of slot position and frequency of the radio channel in use (see clause 7.2.3.2), or blind slot information (see clause 7.2.4.3.3).

7 Medium access layer messages

General remarks:

- 1) When not specially defined, all numbers in A-field or B-field messages are coded with the natural binary value and are arranged such that the Most Significant Bit (MSB) is transmitted first and the Least Significant Bit (LSB) is transmitted last.

EXAMPLE: A five bit number with a value of 12 (decimal) = 01100 (binary) which is transmitted in the bits a_{13} to a_{17} or in the bits bn_{13} to bn_{17} is coded as in figure 7.1.

	0	1	1	0	0	
	MSB				LSB	
	a_{13}	a_{14}	a_{15}	a_{16}	a_{17}	
	bn_{13}	bn_{14}	bn_{15}	bn_{16}	bn_{17}	

Figure 7.1: Most and Last Significant Bit

- 2) "Escape" codes are for proprietary use. The main escape is provided in the tail identification (see clause 7.1.2). Secondary escapes are also provided for proprietary extensions to the messages. These secondary codes shall not be used to replace functions that can be equally provided using DECT standard functions.

- 3) "Reserved" codes are for future DECT CI expansions. These codes shall not be used. These codes may be specified in future revisions of the present document.
- 4) Messages not implemented shall be ignored.

7.1 Header field

7.1.1 Overview/formatting

The header field, H, occupies bits a_0 to a_7 of the A-field. See figure 7.2.

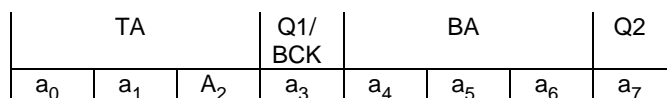

Figure 7.2: Header field formatting

7.1.2 Tail identification, TA, bits a_0 to a_2

These bits describe the contents of the 40 bits that follow the header field. See table 7.1.

Table 7.1: Tail Identification

a_0	a_1	a_2	Tail contents	Restrictions
0	0	0	C_T data packet number 0	
0	0	1	C_T data packet number 1	
0	1	0	if BA bits = 111 (XSync after A-CRC): -> identity information (N_T) on DummyPointer bearer (FT initiated "no-emission" mode wakeup) if BA bits are not "111" (B-field content / see clause 7.1.4): -> identities information (N_T) on connectionless bearer	
0	1	1	identities information (N_T)	
1	0	0	multiframe synchronization and system information (Q_T)	
1	0	1	reserved	
1	1	0	MAC layer control (M_T)	
1	1	1	paging tail (P_T)	RFP only
1	1	1	first PP transmission (M_T)	PP only
"RFP only" means: RFP transmissions only. "PP only" means: PP transmissions only. See clause 10.5.1.7 for description about the use of the TA code "111" first PP transmission.				

NOTE: Rigorous testing of all possible reserved tails is not intended. A manufacturer's declaration is appropriate.

When the escape code is used it shall appear in every header and no other TA code shall be used. The escape code indicates the use of proprietary protocols and no compatibility with the standard protocol can be assumed (see EN 300 175-1 [1]).

7.1.3 The "Q1/BCK" bit, bit a_3

The bit a_3 has only a defined meaning for duplex traffic bearers, i.e. duplex bearers in connection oriented services. For all other bearers and services this bit is set to "0".

For duplex bearers of a MAC layer I_p _error_correction service (connection oriented service) this bit is the "BCK" bit and is used for I_p channel flow control. Its value is defined by the procedures given in clause 10.8.2.

For duplex bearers of all the other connection oriented MAC layer services, this bit is the "Q1" bit and used for bearer quality control. Its value is defined by the procedures given in clause 10.8.1.3.

7.1.4 B-field identification, BA, bits a_4 to a_6

These bits describe the contents of the B-field that follows the A-field. See table 7.2.

Table 7.2: B-field ID

a_4	a_5	a_6	B-field contents
0	0	0	U-type, I_N , SI_N , or I_P packet number 0 or no valid $I_P_error_detect$ channel data
0	0	1	U-type, $I_P_error_detect$ or I_P packet number 1 or SI_N or no valid I_N channel data
0	1	0	E-type, all C_F or CL_F , packet number 0
0	1	0	double slot required
0	1	1	E-type, all C_F , packet number 1
1	0	0	E-type, not all C_F or CL_F ; C_F packet number 0 (note 5)
1	0	0	half slot required
1	0	1	E-type, not all C_F ; C_F packet number 1 (note 5)
1	0	1	long slot ($j=640$) required
1	1	0	E+U-type (if regular U-plane service is I_N or $I_P_error_detect$) OR E+U type, packet number 0 (if regular U-plane service is $I_P_error_correct$) OR E-type all MAC signalling (notes 3, 4 and 5)
1	1	0	long slot ($j=672$) required
1	1	1	E+U-type, packet number 1 (if regular U-plane service is $I_P_error_correct$) OR no B-field (if regular U-plane service is I_N or $I_P_error_detect$) (notes 3 to 7)

NOTE 1: The 000 code may be used to indicate that the B-field does not contain valid data, only for an already established $I_P_error_detect$ connection.

NOTE 2: The 001 code may be used to indicate that the B-field does not contain valid data, only for an already established I_N connection.

NOTE 3: The E+U type mux (codes 110 and 111) allows the transmission of MAC messages (e.g. bearer quality report for a duplex bearer of an asymmetric connection) and U-type data in one B-field.

NOTE 4: The 111 is only used to indicate E+U mux if MAC service is $I_P_error_correct$. For I_N , SI_N and $I_P_error_detect$, this code indicates no valid B-field.

NOTE 5: All MAC control (all subfields carrying MAC signalling or G_F) can be also transmitted using codes 100 and 101 if C_F channel is supported, and 111 if MAC service is $I_P_error_correct$.

NOTE 6: For $I_P_error_correct$, no B-field may be implemented using the MAC control message "NULL" in all subfields.

NOTE 7: However, when used in application profiles where E/U type "E+U" and channel I_{PF} are not supported, it is allowed to use the code "111" to indicate "no B-field" when regular U-plane service is $I_P_error_correct$.

NOTE: Testing of this H-field with all possible T- and B-fields is not intended. A manufacturer's declaration is appropriate.

In relation to a BEARER_REQUEST message of the A-field advanced connection control set and REP connection control set, the a_4 , a_5 , a_6 bits shall indicate the following:

010: "double slot required";

B-field does not contain valid logical channel data

100: "half slot required";

B-field does not contain valid logical channel data

101: "long slot ($j=640$) required";

B-field does not contain valid logical channel data

110: "long slot ($j=672$) required";

B-field does not contain valid logical channel data

The first response from the called side shall use the same BA bits setting used by the calling side and the B-field does not contain valid logical channel data. In the following messages, the BA bits shall indicate the logical channels contained in the B-field.

In relation to a BEARER_REQUEST message of the A-field advanced connection control set and REP connection control set, all other codings shall indicate full slot with the B-field contents described above.

In relation to a BEARER_REQUEST message of the B-field advanced connection control set the a_4 , a_5 , a_6 bits shall indicate the following:

010: "double slot required";

101: "long slot ($j=640$) required";

110: "long slot ($j=672$) required";

100: "half slot required".

In the first response from the called side and in the following messages, the BA bits shall indicate the logical channels contained in the B-field.

7.1.5 The "Q2" bit, bit a_7

The bit a_7 has only a defined meaning for duplex traffic bearers, i.e. duplex bearers in connection oriented services. For all other bearers and services this bit is set to "0".

For duplex bearers of connection oriented MAC layer services, this bit is the "Q2" bit and used for bearer quality control and C channel flow control. Its value is defined by the procedures given in clause 10.8.1.3 for I_N and $I_p_error_detection$ services and in clause 10.8.2.4 for $I_p_error_correction$ services.

7.2 Messages in the tail field

7.2.1 Overview

Several different messages may be multiplexed into the tail field, according to the T-MUX algorithm defined in clause 6.2.2.1. The contents of the tail field are defined for each frame by the tail identification bits defined in clause 7.1.2.

Each tail message has a fixed length of 40 bits. In the following descriptions the mapping of the message into the A-field is shown. The first bit of the message always appears in bit position a_8 as shown in figure 7.3.

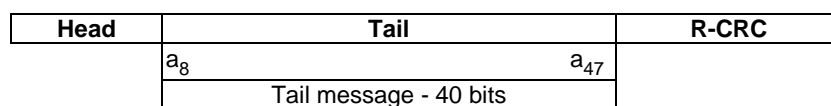

Figure 7.3: Tail field

The following tail messages are defined:

- N channel messages (see clause 7.2.2);
- Q channel messages (see clause 7.2.3);
- P channel messages (see clause 7.2.4);
- M channel messages (see clause 7.2.5).

7.2.2 Identities information (N_T)

The management entity in the RFP supplies the MAC layer with the primary access rights identifier, an SDU of either 32 bits or 37 bits passed through the ME SAP. The RFP adds its radio fixed part number (8 bits or 3 bits) RPN to this SDU so that the RPN forms the least significant bits of the resulting 40 bit field. The complete 40 bit message forms the radio fixed part identity (see EN 300 175-6 [6]), and this is the only message that appears in N_T type tails sent by the RFP. The least significant bit of RFPI is placed in bit position a_{47} .

NT type tails sent by a PT contain the RFPI of that RFP with which it is maintaining the bearer.

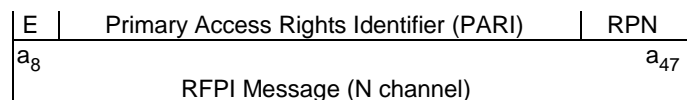

Figure 7.4

7.2.3 System information and multiframe marker (Q_T)

7.2.3.1 General

The multiframe marker is transmitted once every 16 frames. This marker is combined with the tail code for system information (Q). Q channel information is therefore only transmitted by RFPs once every multiframe.

The basic format of the Q-field is to have a 4 bit header (the Q_H field) followed by a 36 bit information field. See figure 7.5.

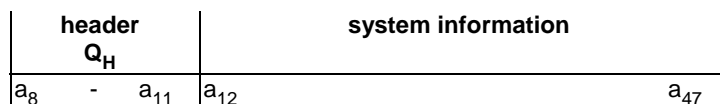

Figure 7.5: System Information field

The Q_H field is used to identify 16 different system information fields. Any one of these fields can be transmitted in each multiframe. Some of these fields need never be transmitted. PTs are required to understand some of these fields. There is a maximum time interval between transmissions of mandatory fields. The exact sequencing of different Q fields by an RFP is not defined.

Table 7.3

Q_H	SYSTEM INFORMATION	MAN	FREQ (see note 8)
000X	static system info	Yes	8 (16)
0010	extended RF carriers part 1	See note 1	8 (16)
0011	fixed part capabilities	Yes	8 (16)
0100	extended fixed part capabilities	See note 2	8 (16)
0101	SARI list contents	No	8
0110	multi-frame number	See note 3	8 (16)
0111	escape	No	-
1000	obsolete	See note 4	-
1001	extended RF carriers part 2	See note 5	8 (16)
1011	transmit information	See note 6	8 (16)
1100	extended fixed part capabilities part 2	See note 7	8 (16)
1101	extended static system info	No	8 (16)
1110 to 1111	} Reserved		

Q _H	SYSTEM INFORMATION	MAN	FREQ (see note 8)
MAN = Mandatory transmission (Yes/No). FREQ = Repeat interval in multiframe, if implemented. NOTE 1: If an extended frequency allocation is used this message shall be transmitted in the multiframe following every transmission of the static system information. NOTE 2: If extended fixed part capabilities information is available this message shall be transmitted in the multiframe following every transmission of the fixed part capabilities information. NOTE 3: If an RFP implements encryption then this message shall be transmitted at least once every 8 multiframe. NOTE 4: This code has never been defined in the present document, but was defined in an ETSI TS that quickly became obsolete, and should therefore not be used for defining new Q _H messages. NOTE 5: If an extended frequency allocation requires this part 2 message, then it shall be transmitted in the multiframe following every transmission of the extended RF carriers part 1 information. NOTE 6: If local regulation or environment impose specific transmit requirements which differ from the common DECT specification requirements, e.g. transmission power limitations, then the transmission of this message is mandatory. NOTE 7: If the extended fixed part capabilities require this part 2 message, then it shall be transmitted in the multiframe following every transmission of the extended fixed part capabilities (part 1) information. NOTE 8: The target repeat interval value is shown in the Freq column. However, in the worst case, where there are many different Q _t types to transmit, this target value might not be achievable. The maximum repeat interval is shown in parenthesis in the Freq column and this value shall not be exceeded.			

7.2.3.2 Static system information

7.2.3.2.1 General, Q_H = 0, 1 (hex)

See figure 7.6.

Q _H				SN	SP	esc	Txs	Mc	RF-carriers	spr	CN	Ext-System-Info	spr	PSCN
0	0	0	N											
			R											
a ₈			a ₁₁	a ₁₂	a ₁₆	a ₁₈	a ₁₉	a ₂₁	a ₂₂	a ₃₂	a ₃₄	a ₄₀	a ₄₁	a ₄₂
				a ₁₅	a ₁₇		a ₂₀		a ₃₁	a ₃₃	a ₃₉			a ₄₇

Figure 7.6: Static System Information

7.2.3.2.2 Q_H and Normal-Reverse (NR)

NR defines whether the RFP is transmitting in its normal half frame, or whether this is the reversed half of an asymmetric connection. See table 7.4.

Table 7.4: NR bit

Bit	Meaning
a ₁₁	
0	"normal" RFP transmit half frame
1	"normal" PP transmit half frame

NOTE: Q_H and NR are combined to allow easier decoding.

7.2.3.2.3 Slot Number (SN)

This defines the number of the slot pair in which this transmission begins. See table 7.5.

Table 7.5: Slot Number

Bits				Meaning
a ₁₂	a ₁₃	a ₁₄	a ₁₅	
0	0	0	0	slot pair {0,12}
0	0	0	1	slot pair {1,13}
0	0	1	0	slot pair {2,14}
0	0	1	1	slot pair {3,15}
0	1	0	0	slot pair {4,16}
0	1	0	1	slot pair {5,17}
0	1	1	0	slot pair {6,18}
0	1	1	1	slot pair {7,19}
1	0	0	0	slot pair {8,20}
1	0	0	1	slot pair {9,21}
1	0	1	0	slot pair {10,22}
1	0	1	1	slot pair {11,23}
1	1	0	0	} reserved
		to		
1	1	1	1	}

7.2.3.2.4 Start Position (SP)

Start position defines the bit in the full slot pair where transmission of the first bit of the S-field starts. See table 7.6.

Table 7.6: Start Position

Bits		Meaning
a ₁₆	a ₁₇	
0	0	S-field starts at bit f0
0	1	reserved for future use
1	0	S-field starts at bit f240
1	1	reserved for future use

NOTE 1: f240 is a "half slot".
NOTE 2: Only full slots starting at bit f0 are currently fully defined.

7.2.3.2.5 ESCape bit (ESC)

When set to "1", indicates that the "escape" Q_T message will be broadcast (see clause 7.2.3.8). See table 7.7.

Table 7.7: ESCape bit

Bit	Meaning
a ₁₈	
0	no "Q _T Escape" is broadcast
1	the "Q _T Escape" is broadcast

7.2.3.2.6 Number of transceivers

This gives the number of transceivers in the RFP. See table 7.8.

Table 7.8: Number of transceivers

Bits		Meaning
a ₁₉	a ₂₀	
0	0	RFP has 1 transceiver
0	1	RFP has 2 transceivers
1	0	RFP has 3 transceivers
1	1	RFP has 4 or more transceivers

7.2.3.2.7 Extended RF carrier information available (Mc)

If the "extended RF carrier information" Q message is transmitted by this RFP, this bit shall be set. The "extended RF carrier information" message shall be transmitted in the multi-frame following this "static system information" message. See table 7.9.

Table 7.9: Extended RF carrier information

Bit	Meaning
a_{21}	
0	no "extended RF carrier information" message
1	"extended RF carrier information" message shall be transmitted in the next multiframe

7.2.3.2.8 RF carriers available (RF-cars)

10 bits are used to tell the PT which of the 10 carriers are available at this RFP.

It is required that all RFPs in the same DECT FP shall have exactly the same RF carriers available.

For bit a_x , $22 \leq x \leq 31$:

- if $a_x = 0$, then RF carrier (x-22) is not available at this RFP;
- else $a_x = 1$ and RF carrier (x-22) is available at this RFP.

a_x shall be set to 1 where local regulatory conditions allow use of the RF carrier.

7.2.3.2.9 Spare bits (SPR)

Until their use is defined, these bits shall not be used. They shall be set equal to "0". See table 7.10.

Table 7.10: Spare bits

bit	Value
a_{32}	0
a_{33}	0

7.2.3.2.10 Carrier number

This defines the number of the RF carrier of this transmission. See table 7.11.

Table 7.11: Carrier number

Bits						Meaning
a_{34}	a_{35}	a_{36}	a_{37}	a_{38}	a_{39}	
0	0	0	0	0	0	RF Carrier 0
0	0	0	0	0	1	RF Carrier 1
0	0	0	0	1	0	RF Carrier 2
..... etc.						
0	0	1	0	0	1	RF Carrier 9
0	0	1	0	1	0	RF Carrier 10
..... etc.						
1	0	0	0	0	0	RF Carrier 32
1	0	0	0	0	1	RF Carrier 33
..... to						
1	1	1	1	1	1	RF Carrier 63

7.2.3.2.11 Extended static system information available (Ext-System-Info) and spare bit

7.2.3.2.11.1 Extended static system information available (Ext-System-Info)

When set to "1", indicates that the "extended static system information" Q_T message will be broadcasted (see clause 7.2.3.12). See table 7.12.

Table 7.12: Extended static system info bit

Bit	Meaning
a_{40}	
0	no " Q_T extended static system information" is broadcasted
1	the " Q_T extended static system information" is broadcasted

7.2.3.2.11.2 Spare bit (SPR)

Until its use is defined, this bit shall not be used. It shall be set equal to "0". See table 7.12a.

Table 7.12a: Spare bits

bit	Value
a_{41}	0

7.2.3.2.12 Primary receiver Scan Carrier Number (PSCN)

The PSCN defines the RF carrier on which one receiver will be listening on the next frame when only one receiver is idle. See table 7.13.

Table 7.13

Bits						Meaning
a_{42}	a_{43}	a_{44}	a_{45}	a_{46}	a_{47}	
0	0	0	0	0	0	primary scan next on RF Carrier 0
0	0	0	0	0	1	primary scan next on RF Carrier 1
0	0	0	0	1	0	primary scan next on RF Carrier 2
..... etc.						
0	0	1	0	0	1	primary scan next on RF Carrier 9
0	0	1	0	1	0	primary scan next on RF Carrier 10
..... etc.						
1	0	0	0	0	0	primary scan next on RF Carrier 32
1	0	0	0	0	1	primary scan next on RF Carrier 33
..... to						
1	1	1	1	1	1	primary scan next on RF Carrier 63

NOTE: In normal systems the value in the PSCN field may change with each transmission (as PSCN has a 10 frame cycle and Q messages have a 16 frame cycle).

7.2.3.3 Extended RF carrier information part 1

7.2.3.3.1 General, $Q_H = 2$ (hex)

The transmission of this message is mandatory if a DECT FT is able to transmit on a RF carrier that is not in the set {0, 1, 2, 3, 4, 5, 6, 7, 8, 9}.

All PTs shall be able to understand bits a_8 to a_{11} , and bits a_{42} to a_{47} inclusive, of this message. See figure 7.7.

Q_H				RF carriers		RF band		Further RF carrier extension	0 spr	number of RF Carriers	
0	0	1	0								
a_8		a_{11}		a_{12}	a_{34}	a_{35}	a_{39}	a_{40}	a_{41}	a_{42}	a_{47}

Figure 7.7: Extended RF carrier information part 1

23 bits are used to tell the PT which of the additional 23 carriers in the set {10, 11, 12..., 32} are available at this RFP.

For bit a_x , $12 \leq x \leq 34$:

- if $a_x = 0$ then RF carrier (x-2) is not available at this RFP;
- else $a_x = 1$ and RF carrier (x-2) is available at this RFP.

The relation between carrier frequency and carrier number is defined in the Physical Layer specification and depends on the RF band number.

Bits a_{35} to a_{39} give the number of the RF band. Bit a_{39} is the least significant bit. The RF band numbers to be used are defined by the Physical Layer specification.

7.2.3.3.2 Further RF carrier extensions

Bit a_{40} indicates if the Q_H message 9 (hex) "Extended RF carrier information part 2" below is sent or not:

- if $a_{40} = 0$, then the Q_H message 9 (hex) "Extended RF carrier information part 2" below is not sent;
- if $a_{40} = 1$, then the Q_H message 9 (hex) "Extended RF carrier information part 2" below is sent, and the PP shall read and properly utilize the information.

7.2.3.3.3 Number of RF carriers

Bits a_{42} to a_{47} give the total number of RF carriers that the RFP scans in a regular sequence. Bit a_{47} is the least significant bit.

NOTE: The coding of bits a_{12} to a_{39} , inclusive, is left for future standardization when additional frequencies are allocated.

7.2.3.4 Fixed part capabilities

7.2.3.4.1 General, $Q_H = 3$ (hex)

A PT shall understand the bits in this message that relate to the service that the PT requires; e.g. if the PT needs an RFP with frequency control, the PT shall be able to understand the bit that says whether the RFP implements frequency control. See figure 7.8.

Q_H		capabilities available information	
0	1		
a_8	a_{11}	a_{12}	a_{47}

Figure 7.8: Fixed Part Capabilities

7.2.3.4.2 Standard capabilities

NOTE: Fixed part capabilities relate to the whole FP. Other capabilities are defined, which relate to, for example, a specific cluster or a specific RFP.

0011		Physical and MAC layer capabilities	Higher layer information
a ₈	a ₁₁	a ₁₂	a ₃₁ a ₃₂ a ₄₇

Figure 7.9

Physical and MAC layer capabilities available:

If a capability is available:

then bit a_x shall be set to 1;

else (capability is not available) the bit a_x shall be set to 0.

Reserved bits shall be set to 0.

Table 7.14

Bit number	Capability
a ₁₂	extended FP Info (Q _H = 4)
a ₁₃	double duplex bearer connections
a ₁₄	reserved
a ₁₅	double slot
a ₁₆	half slot
a ₁₇	full slot
a ₁₈	frequency control
a ₁₉	page repetition
a ₂₀	C/O setup on dummy allowed
a ₂₁	C/L uplink
a ₂₂	C/L downlink
a ₂₃	basic A-field set-up
a ₂₄	advanced A-field set-up
a ₂₅	B-field set-up
a ₂₆	C _F messages
a ₂₇	I _{NA} _minimum_delay
a ₂₈	I _{NB} _normal_delay
a ₂₉	I _{PM} _error_detection
a ₃₀	I _{PMR} _error_correction (or I _{PQR} _error_correction, see note 3)
a ₃₁	multibearer connections
NOTE 1: Bit a ₁₉ indicates whether or not Idle_Locked PPs may enter the low duty cycle Idle_Locked mode (see clause 11.3.3.1).	
NOTE 2: The bits a ₂₁ and a ₂₂ indicate only the capabilities of the FT to provide connectionless services in the uplink or downlink direction. They do not indicate if these services are active when the message is transmitted.	
NOTE 3: The support of MAC service I _{PQR} error correct shall be coded and deducted from the setting of this bit and bit a ₂₂ of extended MAC layer capability (see clause 7.2.3.5.2.4).	

Higher layer information:

The management entity in the fixed part supplies the MAC layer with a 16 bit SDU via the ME SAP. At the PT the MAC layer passes the 16 bits out through the ME SAP to the management entity.

For the setting of the higher layer information bits refer to annex F of EN 300 175-5 [5].

7.2.3.5 Extended fixed part capabilities

7.2.3.5.1 General, $Q_H = 4$ (hex)

Part of this message is reserved for future standardization. See figures 7.10 and 7.11.

NOTE: Bit a_{12} of the standard capabilities message (see clause 7.2.3.4) indicates whether or not this message is broadcast.

QH 0100		Extended Physical and MAC layer capabilities			Extended Higher layer capabilities	
a_8	a_{11}	a_{12}		a_{24}	a_{25}	a_{47}

Figure 7.10: Extended fixed parts capabilities

7.2.3.5.2 Extended Physical and MAC layer capabilities

The bits for which the coding is not defined shall be set to 0. These bits are left for future standardization.

Figure 7.11 presents the structure of the extended physical and MAC layer capabilities field.

Wireless relay stations		Synchronization field		Reserved	MAC suspend and resume	IPQ services supported	Extended FP info part 2	Reserved for further standardization
a_{12}	a_{17}	a_{18}	a_{19}	a_{20}	a_{21}	a_{22}	a_{23}	a_{24}

Figure 7.11: Extended physical and MAC layer capabilities

7.2.3.5.2.1 Wireless Relay Stations

The definition of the WRS support field, a_{12} to a_{17} is given in table 7.15. The default value of the WRS support field is all bits set to 0.

Table 7.15: Wireless Relay Stations

WRS support	CRFP bits			REP bits			Meaning
	a_{12}	a_{13}	a_{14}	a_{15}	a_{16}	a_{17}	
CRFP Hops:	0	0	x	x	x	x	1 CRFP is allowed
The number of CRFPs allowed to be cascaded with the part with received RFPI	0	1	x	x	x	x	2 CRFP allowed in cascade
	1	0	x	x	x	x	3 CRFP allowed in cascade
	1	1	x	x	x	x	No CRFP allowed
CRFP encryption	x	x	0	x	x	x	CRFP encryption not supported
	x	x	1	x	x	x	CRFP encryption supported
REP hops:	x	x	x	0	0	x	REP not supported
The number of REPs allowed to be cascaded with the part with received RFPI	x	x	x	0	1	x	1 REP is allowed
	x	x	x	1	0	x	2 REP are allowed in cascade
	x	x	x	1	1	x	3 REP are allowed in cascade
REP capabilities	x	x	x	x	x	0	REP interlacing not supported
	x	x	x	x	x	1	REP interlacing supported

7.2.3.5.2.2 Synchronization field options

Bits a_{18} and a_{19} define the synchronization field options support as given in table 7.16.

Table 7.16: Synchronization field options

Bits		Meaning
a_{18}	a_{19}	
0	0	standard, see EN 300 175-2 [2], clauses 4.6 and 5.2
0	1	prolonged preamble, see EN 300 175-2 [2], annex C (see note)
1	0	reserved
1	1	reserved

NOTE: This message indicates that the FT is capable of using the prolonged preamble and is transmitting the prolonged preamble. When a PT receives this message, and is capable of using the prolonged preamble and/or is capable of transmitting the prolonged preamble then it should use the extended channel selection window (see EN 300 175-2 [2], clause 8.3).

7.2.3.5.2.3 MAC suspend and resume

Bit a_{21} indicates support of the MAC suspend and resume procedures (see clause 10.3.1.1) when set to 1.

7.2.3.5.2.4 MAC service I_{PQ} supported

Bit a_{22} indicates support of the MAC service I_{PQ} to transport I_P channel data using a single subfield protected B-field format as defined by clauses 5.6.2.1 and 5.6.2.2 when set to 1.

The support of MAC service I_{PQR} error correct shall be coded and deducted from the setting of this bit and bit a_{30} of standard MAC layer capability (see clause 7.2.3.4.2). If both bits are set, it shall be understood that I_{PQR} error correct is supported.

7.2.3.5.3 Extended higher layer capabilities

Figure 7.12 presents the structure of the extended higher layer capabilities field.

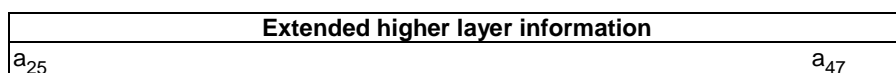

Figure 7.12: Extended higher layer information field

The coding and the meaning of these bits are defined in annex F of EN 300 175-5 [5]. The bits for which the coding is not defined shall be set to 0.

7.2.3.6 Secondary access rights identities

7.2.3.6.1 General, $Q_H = 5$ (hex)

The transmission of this message is optional, subject to the existence of one or more valid SARIs (see figure 7.13).

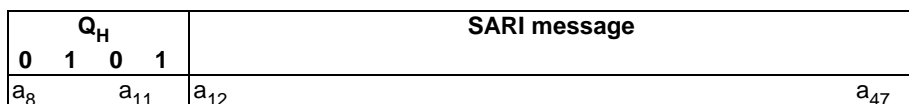

Figure 7.13: SARI message field

7.2.3.6.2 SARI message

The management entity in the fixed part supplies the MAC layer with a 36 bit SDU via the ME SAP. At the PT the MAC layer passes the 36 bits out through the ME SAP to the management entity. See EN 300 175-6 [6].

7.2.3.7 Multiframe number

7.2.3.7.1 General, $Q_H = 6$ (hex)

All PTs that support encryption shall understand this message (see figure 7.14).

Q_H				(spare)		multiframe number	
0	1	1	0	1111 0000 1111			
a_8	a_{11}			a_{12}	a_{23}		a_{47}

Figure 7.14: Multiframe number

7.2.3.7.2 Multiframe number

This is the number of the multiframe, modulo 2^{24} . The least significant bit of the multiframe number is placed in bit position a_{47} .

If encryption is supported, the multiframe number shall be the same across the whole of a DECT FP.

7.2.3.8 Escape

7.2.3.8.1 General, $Q_H = 7$ (hex)

The transmission of this message is optional.

Any DECT RFP may transmit an escape message. See figure 7.15.

Q_H				escape information			
0	1	1	1				
a_8	a_{11}			a_{12}	a_{47}		

Figure 7.15: Escape

7.2.3.8.2 Escape information

The content of the escape information field (a_{12} to a_{47}) is not specified. This message is provided for application specific use.

7.2.3.9 Extended RF carrier information part 2

7.2.3.9.1 General, $Q_H = 9$ (hex)

The transmission of this message is mandatory if a DECT FT is able to transmit on a RF carrier that is not in the set {0, 1, 2, 3, ..., 30, 31, 32}.

All PTs shall be able to understand bits a_8 to a_{42} of this message. See figure 7.15a.

Q_H				RF carriers		spare	
1	0	0	1	00000			
a_8	a_{11}			a_{12}	a_{42}		a_{43} a_{47}

Figure 7.15a: Extended RF carrier information part 2

31 bits are used to tell the PT which of the additional 31 carriers in the set {33, 34, ..., 63} are available at this RFP.

For bit a_x , $12 \leq x \leq 42$:

- if $a_x = 0$ then RF carrier $(x + 21)$ is not available at this RFP;
- else $a_x = 1$ then RF carrier $(x + 21)$ is available at this RFP.

The relation between carrier frequency and carrier number is defined in EN 300 175-2 [2] and depends on the RF band number indicated in clause 7.2.3.3 Extended RF carrier information part 1.

7.2.3.10 Transmit information

7.2.3.10.1 General, $Q_H = B$ (hex)

The transmit information is used to indicate to the PTs local conditions and restrictions, e.g. the maximum allowed transmit power.

Q_H				TX type		power level		(spare)	
1	0	1	1					00000000...	0000
a_8		a_{11}		a_{12}	a_{15}	a_{16}	a_{23}	a_{24}	a_{47}

Figure 7.15b: Transmit information

Table 7.16a: TX type field

a_{12}	a_{13}	a_{14}	a_{15}	TX type
0	0	0	0	maximum transmit power
0	0	0	1	reserved
0	0	1	0	reserved
0	0	1	1	reserved
0	1	0	0	reserved
0	1	0	1	bandwidth dependant maximum transmit power (see note)
0	1	1	0	reserved
0	1	1	1	reserved
1	0	0	0	reserved
1	0	0	1	reserved
1	0	1	0	reserved
1	0	1	1	reserved
1	1	0	0	reserved
1	1	0	1	reserved
1	1	1	0	reserved
1	1	1	1	reserved

NOTE: The maximum transmit power is equal to the value given in "power level" field multiplied with the square root of the emission bandwidth measured in MHz. The emission bandwidth shall be determined by measuring the width of the signal between two points, one below the carrier center frequency and one above the carrier center frequency, that are 26 dB down relative to the maximum level of the modulated carrier.

Power level field

Bits a_{16} to a_{23} in the "power level" field give the binary encoded value of the maximum transmit power in mW. Bit a_{23} is the least significant bit.

Spare bits

The spare bits a_{24} to a_{47} shall be set to zero.

7.2.3.11 Extended fixed part capabilities (part 2)

7.2.3.11.1 General, $Q_H = C$ (hex)

NOTE: Bit a_{23} of the extended FP capabilities message (see clause 7.2.3.5) indicates whether or not this message is broadcast.

1100		Extended Physical and MAC layer capabilities (part 2)	Extended Higher layer information (part 2)
a_8	a_{11}	a_{12}	a_{23}
			a_{24}
			a_{47}

Figure 7.15c

7.2.3.11.2 Extended Physical and MAC layer capabilities (part 2)

- If a capability is available:
 - then bit a_x shall be set to 1;
- else (capability is not available) the bit a_x shall be set to 0.
- Reserved bits shall be set to 0.

Table 7.16b

Bit number	Capability
a_{12}	Long slot support ($j=640$)
a_{13}	Long slot support ($j=672$)
a_{14}	E+U-type mux and channel I_{PF} basic procedures supported (see note 1)
a_{15}	channel I_{PF} advanced procedures supported (see note 1)
a_{16}	channel SI_{PF} supported (see notes 1 and 2)
a_{17}	channel G_F supported (see note 3)
$a_{18} - a_{22}$	Reserved for future standardization
a_{23}	"no-emission" mode: preferred carrier number mode (CN)
NOTE 1: See clauses 5.3.1.4 and 6.2.2.2 for description of the I_{PF} channel and the E+U-type multiplexer.	
NOTE 2: Requires the support of the SI_P channel. See clause 5.3.2.3 for description of SI_{PF} channel.	
NOTE 3: This bit indicates that the FT has the ability to receive the G_F channel.	

Setting of bit a_{23} : "no-emission" mode

$a_{23} = 1$: variable preferred CN/every CN possible

$a_{23} = 0$: fixed preferred CN

The preferred carrier number is selected and broadcasted by the FT (PT broadcast info) FT:

- if ($a_{23} = 1$), then DummyPointer-wakeups on all carriers should be done after reset
- if ($a_{23} = 0$), then DummyPointer-wakeup only on the known preferred carrier should be done after reset

PT:

- check capability "no-emission" mode: preferred carrier number mode
- if ($a_{23} = 1$), then DummyRequest-wakeups on all carriers should be done after reset or asynchronous mode
- if ($a_{23} = 0$), then DummyRequest-wakeup only on the known preferred carrier should be done after reset or asynchronous mode

7.2.3.11.3 Extended higher layer capabilities (part 2)

The coding and the meaning of these bits are defined in annex F of EN 300 175-5 [5]. The bits for which the coding is not defined shall be set to 0.

7.2.3.12 Extended static system information

7.2.3.12.1 General, $Q_H = D$ (hex)

See figure 7.15d.

Q_H		Spare		RFP slot scheme info	
1	1 0 1				
a_8	a_{11}	a_{12}	a_{43}	a_{44}	a_{47}

Figure 7.15d: Extended Static System Information

7.2.3.12.2 Spare bits (Spare)

Until their use is defined, these bits shall not be used. They shall be set equal to "0". See table 7.16c.

Table 7.16c: Spare bits

bit	Value
$a_{12} \dots a_{43}$	0

7.2.3.12.3 RFP slot scheme info

This defines which slots will be potentially available on the RFPs in the system. PP may use this system wide static information until blind slot information of the currently locked RFP is received, e.g. in case of intercell handover. See table 7.16d.

Table 7.16d: RFP slot scheme info

Bits				Meaning
a_{44}	a_{45}	a_{46}	a_{47}	
0	0	0	0	No info (default), see note 1
0	0	0	1	Only odd slots (1,3,5, ...) will be potentially available on all RFPs in the system
0	0	1	0	Only even slots (0,2,4, ...) will be potentially available on all RFPs in the system
0	0	1	1	It depends on RPN, which slot scheme will be potentially available on the RFP: RPN=xxxxxx0: even slots (0,2,4, ...) will be potentially available on this RFP RPN=xxxxxx1: odd slots (1,3,5, ...) will be potentially available on this RFP
0	1	0	0	It depends on RPN, which slot scheme will be potentially available on the RFP: RPN=xxxxxx1: even slots (0,2,4, ...) will be potentially available on this RFP RPN=xxxxxx0: odd slots (1,3,5, ...) will be potentially available on this RFP
0	1	0	1	It depends on RPN, which slot scheme will be potentially available on the RFP: RPN=0,1: even slots (0,2,4, ...) will be potentially available on this RFP RPN>1: all slots will be potentially available on this RFP (see note 2)
0	1	1	0	} reserved
1	1	1	1	

Bits				Meaning
a ₄₄	a ₄₅	a ₄₆	a ₄₇	
NOTE 1: Until a P _T -blind slot info (see clause 7.2.4) is received, the PP assumes that all slots are available for all RFPs in the system.				
NOTE 2: Used in typical residential class A repeater systems.				

7.2.4 Paging Tail (P_T)

7.2.4.1 General format

7.2.4.1.1 P_T format for full and long page messages

P _T header	36 bits of B _S channel data			
a ₈	a ₁₁	a ₁₂		a ₄₇

Figure 7.16: P_T format for full and long page messages

7.2.4.1.2 P_T format for short page messages

P _T header	20 bits of B _S channel data		info type	MAC Layer information	
a ₈	a ₁₁	a ₁₂	a ₃₁	a ₃₂	a ₃₅
				a ₃₆	a ₄₇

Figure 7.17: P_T format for short page messages

7.2.4.1.3 P_T format for zero length page messages

P _T header	20 least significant bits of RFPI		info type	MAC Layer information	
a ₈	a ₁₁	a ₁₂	a ₃₁	a ₃₂	a ₃₅
				a ₃₆	a ₄₇

Figure 7.18: P_T format for zero length page messages

7.2.4.1.4 P_T format for MAC_Resume_and_Control_page message

P _T Header=x011	PMID (20 bits)	ECN/info 3	Command	Info 1	Info 2
a ₈	a ₁₁	a ₁₂	a ₃₁	a ₃₂	a ₃₅
			a ₃₆	a ₃₇	a ₃₈
				a ₄₁	a ₄₂
					a ₄₇

Figure 7.19: P_T format for MAC_resume and control page messages

Table 7.16e: MAC resume and control page commands

ECN/info 3	Command	Info 1	Info 2	Meaning
a ₃₂ a ₃₅	a ₃₆ a ₃₇	a ₃₈ a ₄₁	a ₄₂ a ₄₇	
ECN of the connection to be resumed	11	1111	111111	RESUME (no special slot or channel list)
ECN of the connection to be resumed	11	Any other value: SN	111111	RESUME on slot SN, standard scan sequence (equivalent to the channel list command LISTEN)
ECN of the connection to be resumed	11	Any other value: SN	Any other value: CN	RESUME on slot SN, channel CN (equivalent to the channel list command LISTEN)

ECN/info 3	Command	Info 1	Info 2	Meaning
0000	10	1111	111111	PASS to idle_locked_state with setup detection (all slots), standard fast setup scan sequence
0000	10	Any other value: SN	111111	PASS to idle_locked_state with selective setup detection in slot SN, standard fast setup scan sequence
0001 (all higher values reserved)	10	Any other value: SN	111111	PASS to idle_locked_state with selective setup detection in slots SN and SN +6 (SEL 2 mode), standard fast setup scan sequence
0010 (all higher values reserved)	10	Any other value: SN	111111	PASS to idle_locked_state with selective setup detection in slots SN and SN +2 (SEL 2B mode), standard fast setup scan sequence
0000 (all other values reserved)	01	1111	111111	PASS to high duty cycle paging detection
0000 (all other values reserved)	01	1110	111111	PASS to normal duty cycle paging detection

All other values: reserved.

The coding of SN and CN are the same as in the "static system information" described in clause 7.2.3.2. The CN=63 cannot be signalled by this message.

7.2.4.2 P_T header format

7.2.4.2.1 General format

extend flag	B_S SDU length indication	
a_8	a_9	a_{11}

Figure 7.20

7.2.4.2.2 Bit a_8 is the extend flag

$a_8 = 0$: the next occurrence of a normal page shall be in a frame 0.

$a_8 = 1$: another page message shall start in the next frame in this multiframe that is permitted to contain a PT type tail.

7.2.4.2.3 B_S SDU length indication

Table 7.17

a_9	a_{10}	a_{11}	Length indication
0	0	0	zero length page
0	0	1	short page
0	1	0	full page
0	1	1	MAC resume and control page
1	0	0	not the last 36 bits of a long page
1	0	1	the first 36 bits of a long page
1	1	0	the last 36 bits of a long page
1	1	1	all of a long page (first and last)

7.2.4.3 MAC layer information for PT

7.2.4.3.1 Information type

Table 7.18

a ₃₂	a ₃₃	a ₃₄	a ₃₅	Information type
0	0	0	0	fill bits / blind long slot (j=640/672) information
0	0	0	1	blind full slot information for circuit mode service
0	0	1	0	other bearer
0	0	1	1	recommended other bearer
0	1	0	0	good RFP bearer
0	1	0	1	dummy or C/L bearer position
0	1	1	0	extended modulation types
0	1	1	1	escape
1	0	0	0	dummy or C/L bearer marker
1	0	0	1	bearer handover/replacement and no-emission mode information
1	0	1	0	RFP status and modulation types
1	0	1	1	active carriers
1	1	0	0	C/L bearer position
1	1	0	1	RFP power level
1	1	1	0	blind double slot/RFP-FP interface resource information
1	1	1	1	blind full slot information for packet mode service

7.2.4.3.2 Fill bits / Blind long slot (j=640 / j=672) information

The receiving side has to evaluate the bit a₄₇ and decide from this bit whether the P_T information has to be understood as fill bits or blind long slot information.

a₄₇=1:

1	1	1	1	0	0	0	0	1	1	1	1
a ₃₆				a ₃₉				a ₄₀		a ₄₇	

Figure 7.21

a₄₇=0:

blind long slot information						spare	
						0	
a ₃₆				a ₄₆		a ₄₇	

Figure 7.21a

For a_x with 36 ≤ x ≤ 46:

if a_x = 1 then long slot pair {(x-36),(x-24)} is not "blind", i.e. available;

else (a_x = 0) long slot pair {(x-36),(x-24)} is "blind", i.e. not available.

NOTE 1: The blind long slot information applies to the same slot number of all available carriers.

NOTE 2: Long slots (j=640 / j=672) are numbered K = 0 to 22; There is no K = 11 according to EN 300 175-2 [2].

NOTE 3: A long slot pair {(x-36), (x-24)} is equivalent to full slots pairs [{(x-36), (x-24)} AND {(x-35), (x-23)}].

7.2.4.3.3 Blind full slot information

The blind full slot information for circuit mode service is intended for voice and streaming data services, to indicate which slots are available and which slots reserved. The blind full slot information for data mode service is intended for bursty and otherwise non-continuous services. These two messages have equal format of the blind slot mask, see figure 7.22. The two masks can be used to separate the different services, minimizing disturbances to each other. The data mode service may be further subdivided using channel list messages to separate the symmetric from the asymmetric services, because the last may cause even more disturbance on the timeslots where it is allowed.

a_{36}	a_{37}	a_{38}	a_{39}	a_{40}	a_{41}	a_{42}	a_{43}	a_{44}	a_{45}	a_{46}	a_{47}
a_{36}											a_{47}

Figure 7.22: Blind Full Slot Information

For a_x with $36 \leq x \leq 47$:

- if $a_x = 1$: then full slot pair $\{(x-36),(x-24)\}$ is not "blind", i.e. available;
- else ($a_x = 0$) full slot pair $\{(x-36),(x-24)\}$ is "blind", i.e. not available.

NOTE: The blind slot information applies to the same slot number of all available carriers.

7.2.4.3.4 Bearer description

These codings are used to provide bearer information and consist of the following information types:

- other bearer;
- recommended other bearer;
- good RFP bearer;
- dummy or connectionless bearer position; and
- connectionless bearer position.

The meaning of the messages is, however, different:

- "other bearer" means that this RFP has a bearer on the physical channel pair that is described in the remaining 12 bits;
- "recommended other bearer" means that this RFP has another bearer on the physical channel pair that is described in the remaining 12 bits. This message shall not be sent unless the bearer that it is sent on will be released in less than or equal to 4 multiframe;

NOTE 1: The bearer referred to in "other bearer" and "recommended other bearer" can mean any types of bearers indicated in clause 5.5.2.

- "good RFP bearer" means that this RFP thinks that the physical channel pair described in the remaining 12 bits is a good bearer for the PT to use to set-up a bearer with that RFP;
- "dummy or C/L bearer position" describes a dummy bearer position and/or marks the position of the bearer which is used for the downlink connectionless service;

NOTE 2: The "fixed part capabilities message" (see clause 7.2.3.4) defines whether it is prohibited to setup a traffic bearer on this pair of physical channels.

- "C/L bearer position" describes the position of a bearer which is used for the downlink connectionless service.

SN		SP		CN	
a_{36}	a_{39}	a_{40}	a_{41}	a_{42}	a_{47}

Figure 7.23: SP, SN and CN fields

The coding of SP, SN, and CN are the same as in the "static system information" described in clause 7.2.3.2. See figure 7.23.

7.2.4.3.5 Escape

Any DECT RFP may transmit an escape message.

The content of the escape information field (a_{36} to a_{47}) is not specified. This message is provided for proprietary extensions.

7.2.4.3.6 Dummy or connectionless downlink bearer marker

1	1	1	1	0	0	0	0	1	1	1	1
a_{36}			a_{39}	a_{40}							a_{47}

Figure 7.24

This message shall only be transmitted on a dummy bearer or on a connectionless downlink bearer.

7.2.4.3.7 Bearer handover/replacement and no-emission mode information

info type				parameter			
a_{36}			a_{39}	a_{40}			a_{47}

Figure 7.25

Table 7.19

Info type				Parameter								Meaning
0	0	0	0	0	0	0	0	1	1	1	1	no bearer handover/replacement to other RFPs no intracell bearer handover/replacement
0	0	0	1	0	0	0	0	1	1	1	1	no bearer handover/replacement to other RFPs intracell bearer handover/replacement supported
0	0	1	0	0	0	0	0	1	1	1	1	bearer handover/replacement supported in whole internal handover area (see EN 300 175-6 [6])
0	0	1	1	bit mask								bearer handover/replacement supported to all RFPs with an RFPI that differs only in the masked bits, see below
0	1	0	0	0...254: multiframe-countdown 255: countdown stopped								number of multiframe until dummy-bearer is deactivated ("no-emission" mode activated)
0	1	0	1	$a_{40}...a_{41} = 0$ $a_{42}...a_{47} = \text{CN}$								idle-scan carrier number (CN) in "no-emission" mode (coding: see clause 7.2.3.2.10)
0	1	1	0	}								
to				}								reserved
1	1	1	1	}								
Info type "0011": Bit mask.												

The transmitted bit mask serves to test the RFPI of any (new) RFP to determine if a bearer handover/replacement is possible to that new RFP. Bearer handover/replacement to this RFP is only possible if the RFPI of that new RFP only differs from the old (current) RFPI in one or more of the bit positions identified by a "0" in the bit mask. In all cases, the bit mask shall be aligned to the last octet of the RFPI.

NOTE: The RFPI is obtained from the N_T message, (see clause 7.2.2).

EXAMPLE: A bit mask "1111 1000" will allow a bearer handover/replacement to all RFPs with an RFPI that differs only in the last three bits from the RFPI of the current RFP.

Single cell DECT FPs (i.e. only one RFP) shall not broadcast other bearer handover information than info type "0000" and info type "0001".

The maximum multiframe countdown duration is $254 \times 0,16s = 40,64s$. The minimum start value shall be at least N208. If a started countdown is stopped/interrupted before expiring to 0, the value 255 shall be sent at least for N209 multiframe in frame 0.

7.2.4.3.8 RFP status and modulation types

RFP status		Modulation types			
		A-field		(B+Z)-fields	
a ₃₆	a ₃₉	a ₄₀	a ₄₃	a ₄₄	a ₄₇

Figure 7.26

Table 7.20

RFP status				Meaning
x	x	x	0	RFP clear for speech
x	x	x	1	RFP busy for speech (see note 1)
x	x	0	x	system clear
x	x	1	x	system busy (see note 2)
x	0	x	x	asynchronous FP not available
x	1	x	x	asynchronous FP available (see note 3)
0	x	x	x	RFP clear for data
1	x	x	x	RFP busy for data (see note 4)

NOTE 1: "RFP busy for speech" means that the RFP recommends PPs not to send access_request messages for speech towards this RFP.

NOTE 2: "system busy" means that the FP recommends PPs not to send access_request messages towards this FP.

NOTE 3: "asynchronous FP available" means that a PP can expect to find an alternative FP not synchronized to its actual FP and which the PP has access rights to.

NOTE 4: "RFP busy for data" means that the RFP recommends PPs not to send access request messages for data towards this RFP.

NOTE 5: "RFP busy for speech/data" is a suggested indication for RFP that do not support speech/data, but are active in a FP which supports this feature. Typical use of "busy for data" is a WRS with speech only.

Bits a₄₀ to a₄₃ define the modulation schemes supported in the A-field, in addition to the default one.

Table 7.21

a ₄₀	a ₄₁	a ₄₂	a ₄₃	A-field modulation scheme
X	X	X	1	2-level modulation not supported
X	X	X	0	2-level modulation supported
X	X	1	X	4-level modulation supported
X	X	0	X	4-level modulation not supported
X	1	X	X	8-level modulation supported
X	0	X	X	8-level modulation not supported
1	X	X	X	Reserved
0	0	0	1	Escape
0	0	0	0	previous "spare" code: only 2-level modulation supported

NOTE: The "escape" coding means a proprietary modulation scheme.

Bits a₄₄ to a₄₇ define the modulation schemes supported in the (B+Z)-fields, in addition to the default one (see note).

NOTE: The "default" modulation scheme is profile dependant.

Table 7.22

a ₄₄	a ₄₅	a ₄₆	a ₄₇	(B+Z)-fields modulation scheme
X	X	X	1	2-level modulation supported
X	X	X	0	2-level modulation not supported
X	X	1	X	4-level modulation not supported
X	X	0	X	4-level modulation supported
X	1	X	X	8-level modulation not supported
X	0	X	X	8-level modulation supported
0	X	X	X	Reserved
1	1	1	0	Escape
1	1	1	1	Previous "spare" code: only 2-level modulation supported

NOTE: The "escape" coding means a proprietary modulation scheme.

7.2.4.3.9 Active carriers

active carriers		spare	
a ₃₆	a ₄₅	0	0
		a ₄₆	a ₄₇

Figure 7.27

For a_x, with 36 ≤ x ≤ 45:

- if a_x = 0 then RFP is not transmitting on carrier (x-36);
- if a_x = 1 then RFP is active transmitting on carrier (x-36);
- Bits a₄₆ and a₄₇ are spare.

7.2.4.3.10 RFP power level

RFP power		Fading margin		FP/RFP specific	reserved for future development
a ₃₆	a ₃₉	a ₄₀	a ₄₃	a ₄₄	a ₄₅ a ₄₇

Figure 7.28

Procedures for utilizing the RFP power message of figure 7.28 are defined in EN 300 175-2 [2], annex E.

The coding of bits a₃₆ to a₃₉ is shown in table 7.23.

Table 7.23: RFP power message

a ₃₆	a ₃₇	a ₃₈	a ₃₉	RFP power, Pr
1	1	1	1	30 dBm
1	1	1	0	28 dBm
1	1	0	1	26 dBm
etc.				etc.
0	0	0	1	2 dBm
0	0	0	0	0 dBm

The RFP power Pr is the NTP and is derived by multiplying the 4 bit (a₃₆ to a₃₉) binary presented number by 2.

The coding of bits a_{40} to a_{43} is shown in table 7.24.

Table 7.24: Fading margin

a_{40}	a_{41}	a_{42}	a_{43}	Fading margin, MF
1	1	1	1	20 dB
1	1	1	0	19 dB
etc.				etc.
0	0	1	0	7 dB
0	0	0	1	6 dB
0	0	0	0	5 dB

The fading margin MF is derived by adding 5 to the 4 bit (a_{36} to a_{39}) binary presented number.

The RFP/FP specific bit $a_{44} = 1$ indicates that each RFP may have different Pr and/or MF values. $a_{44} = 0$ indicates that all RFPs within the FP have the same values on Pr and MF.

7.2.4.3.11 Blind double slot/RFP-FP interface resource information

blind double slot information		Spare (=0)
a_{36}	a_{46}	a_{47}

Figure 7.29

For a_x with $36 \leq x \leq 46$:

- if $a_x = 1$ then double slot pair $\{(x-36),(x-24)\}$ is not "blind", i.e. available;
- else ($a_x = 0$) double slot pair $\{(x-36),(x-24)\}$ is "blind", i.e. not available.

NOTE 1: The blind double slot information applies to the same slot number of all available carriers.

NOTE 2: Double slots are numbered $K = 0$ to 22; There is no $K=11$ according to EN 300 175-2 [2].

NOTE 3: A double slot pair $\{(x-36), (x-24)\}$ is equivalent to full slots pairs $[\{(x-36), (x-24)\} \text{ AND } \{(x-35), (x-23)\}]$.

Table 7.25: Void

Table 7.26: Void

7.2.4.3.12 Extended modulation types

spare							Extended modulation types (B+Z)-fields	
0	0	0	0	0	0	0	a_{43}	a_{47}
A_{36}							a_{42}	

Figure 7.29a

Bits a_{43} to a_{47} define the modulation schemes supported in the (B+Z)-fields, in addition to the default one (see note in clause 7.2.4.3.8).

Table 7.26a

a ₄₃	a ₄₄	a ₄₅	a ₄₆	a ₄₇	(B+Z)-fields modulation scheme
X	X	X	X	1	2-level modulation supported
X	X	X	X	0	2-level modulation not supported
X	X	X	1	X	4-level modulation not supported
X	X	X	0	X	4-level modulation supported
X	X	1	X	X	8-level modulation not supported
X	X	0	X	X	8-level modulation supported
X	1	X	X	X	16-level modulation not supported
X	0	X	X	X	16-level modulation supported
1	X	X	X	X	64-level modulation not supported
0	X	X	X	X	64-level modulation supported

7.2.5 MAC control (M_T)

7.2.5.1 General format and contents

Two different combinations of TA bits are used to indicate the presence of MAC layer control information in the tail. The "first PT transmission" code is used only in the first transmission from a PT. This is intended to aid RFPs in busy systems to identify bearer set-up requests amongst a background of ongoing connections.

M _T header		command		more headers or information	
a ₈	a ₁₁	a ₁₂	a ₁₅	a ₁₆	a ₄₇

Figure 7.30: M_T messages

M_T messages (see figure 7.30) are sent as 40 bit packets in the tail of the A-field. The first 4 bit header provides a coarse division of messages and for most message types a second header, completing the first octet, provides a finer division of the messages.

Table 7.27

M _T header				Message type
0	0	0	0	basic connection control
0	0	0	1	advanced connection control
0	0	1	0	MAC layer test messages
0	0	1	1	quality control
0	1	0	0	broadcast and connectionless services
0	1	0	1	encryption control
0	1	1	0	Tail for use with the first transmission of a B-field "bearer request" message
0	1	1	1	escape
1	0	0	0	TARI message
1	0	0	1	REP connection control
1	0	1	0	advanced connection control part 2
1	0	1	1	}
to				} reserved
1	1	1	1	}

7.2.5.2 Basic connection control

7.2.5.2.1 General

The basic connection control messages shall only be used by PPs and RFPs that are attempting to establish a single duplex bearer voice connection with a B-field of 324 bits.

7.2.5.2.2 Format for most messages

0 0 0 0	command	FMID	PMID
a ₈ a ₁₁	a ₁₂ a ₁₅	a ₁₆ a ₂₇	a ₂₈ a ₄₇

NOTE: For definitions of FMID, PMID, see clause 11.7.

Figure 7.31

Table 7.28

Command				Basic connection control messages
0	0	0	0	access_request (see note)
0	0	0	1	bearer_handover_request (see note)
0	0	1	0	connection_handover_request (see note)
0	0	1	1	unconfirmed_access_request (see note)
0	1	0	0	bearer_confirm
0	1	0	1	wait (format see clause 7.2.5.2.3)
0	1	1	0	attributes_T_request
0	1	1	1	attributes_T_confirm
1	0	0	0	} reserved
to				
1	1	1	0	} release
1	1	1	1	

NOTE: Indicates messages that use the "first PT transmission" code. The other messages use the normal M_T code.

This release message shall only refer to the bearer that it is transmitted on.

NOTE 1: An RFP that receives an UNCONFIRMED_ACCESS_REQUEST message does not return a BEARER_CONFIRM. It may listen to following frames to receive MAC attributes messages or data.

NOTE 2: The use of the UNCONFIRMED_ACCESS_REQUEST message is intended here for achieving handover by changing base stations but remaining on the same physical channel. The use of this message in basic cases is still uncertain.

NOTE 3: Fast bearer set-up requests are not allowed in basic A-field setups.

The FT may use the messages indicated with ** without the "first PT transmission" code.

7.2.5.2.3 WAIT

0 0 0 0	0 1 0 1	FMID	PMID or spare (1111 0000 1111 0000 1111)
a ₈ a ₁₁	a ₁₂ a ₁₅	a ₁₆ a ₂₇	a ₂₈ a ₄₇

NOTE: The procedure does not make reference to the values of a₁₆ to a₄₇. It is not intended that the contents of this field be included in any mandatory tests.

Figure 7.32

7.2.5.2.4 ATTRIBUTES_T_{Req;Cfm}

0000	011	R/C	ECN	LBN	up/down/ sm/ ss	ser type	ser type/ max life	slot type	C _F	(spare) 111	(spare) 0000	A-field mod type	(B+Z) fields mod. type
a ₈ a ₁₁	a ₁₂ a ₁₅	a ₁₆ a ₁₉	a ₂₀ a ₂₃	a ₂₄ a ₂₅	a ₂₆ a ₂₈	a ₂₉ a ₃₁	a ₃₂ a ₃₅	a ₃₆	a ₃₇ a ₃₉	a ₄₀ a ₄₃	a ₄₄ a ₄₅	a ₄₆ a ₄₇	

Figure 7.33

For all the parameter codings see clause 7.2.5.3.8.

7.2.5.3 Advanced connection control

NOTE: See also clause 7.2.5.12 "Advanced connection control part 2".

7.2.5.3.1 General

Table 7.29

Command				Advanced connection control messages
0	0	0	0	ACCESS_REQUEST (see note)
0	0	0	1	bearer_handover_request (see note)
0	0	1	0	connection_handover_request (see note)
0	0	1	1	unconfirmed_access_request (see note)
0	1	0	0	bearer_confirm
0	1	0	1	wait (contains FMID)
0	1	1	0	attributes_T_request
0	1	1	1	attributes_T_confirm
1	0	0	0	bandwidth_T_request
1	0	0	1	bandwidth_T_confirm
1	0	1	0	channel_list
1	0	1	1	unconfirmed_dummy (see note)
1	1	0	0	unconfirmed_handover (see note)
1	1	0	1	reserved
1	1	1	0	reserved
1	1	1	1	release

NOTE: Indicates messages that, if transmitted by a PT, use the "first PT transmission" code.

These messages allow an advanced connection to be established using M_T messages. The connection set-up time is expected to be much longer than if MAC control messages are sent in the B-field.

The FT may use the messages indicated with ** without the "first PT transmission" code.

7.2.5.3.2 ACCESS_REQUEST

0	0	0	1	0	0	0	0	FMID	PMID		
a_8		a_{11}		a_{12}		a_{15}		a_{16}	a_{27}	a_{28}	a_{47}

Figure 7.34

7.2.5.3.3 BEARER_HANDOVER_REQUEST

0	0	0	1	0	0	0	1	FMID	PMID		
a_8		a_{11}		a_{12}		a_{15}		a_{16}	a_{27}	a_{28}	a_{47}

Figure 7.35

7.2.5.3.4 CONNECTION_HANDOVER_REQUEST

0	0	0	1	0	0	1	0	FMID	PMID		
a_8		a_{11}		a_{12}		a_{15}		a_{16}	a_{27}	a_{28}	a_{47}

Figure 7.36

7.2.5.3.5 UNCONFIRMED_ACCESS_REQUEST

0	0	0	1	0	0	1	1	F MID	PMID			
a ₈		a ₁₁		a ₁₂		a ₁₅		a ₁₆	a ₂₇	a ₂₈		a ₄₇

NOTE: An RFP or a PP that receives an UNCONFIRMED_ACCESS_REQUEST message does not return a confirm. It may listen to following frames to receive MAC attributes messages or data.

Figure 7.37

7.2.5.3.6 BEARER_CONFIRM

0	0	0	1	0	1	0	0	F MID	PMID			
a ₈		a ₁₁		a ₁₂		a ₁₅		a ₁₆	a ₂₇	a ₂₈		a ₄₇

Figure 7.38

7.2.5.3.7 WAIT

0	0	0	1	0	1	0	1	F MID	PMID or spare (1111 0000 1111 0000 1111)			
a ₈		a ₁₁		a ₁₂		a ₁₅		a ₁₆	a ₂₇	a ₂₈		a ₄₇

NOTE: The procedure does not make reference to the values of a₁₆ to a₄₇. It is not intended that the contents of this field be included in any mandatory tests.

Figure 7.39

7.2.5.3.8 ATTRIBUTES_T_{Req;Cfm}

0001	011	R/C	ECN	LBN	up/down/ sm/ss	ser type	ser type/ max life	slot type	C _F	(B+Z) fields ext. mod. type	adaptive code rate	A-field mod type	(B+Z) fields mod. type											
a ₈	a ₁₁	a ₁₂	a ₁₅	a ₁₆	a ₁₉	a ₂₀	a ₂₃	a ₂₄	a ₂₅	a ₂₆	a ₂₈	a ₂₉	a ₃₁	a ₃₂	a ₃₅	a ₃₆	a ₃₇	a ₃₉	a ₄₀	a ₄₃	a ₄₄	a ₄₅	a ₄₄	a ₄₇

Figure 7.40

R/C: indicates if the message is a request or a confirm.

Table 7.30

R/C	Meaning
0	request
1	confirm

ECN: is the Exchanged Connection Number.

ECN: Exchanged Connection Number.

LBN: is the Logical Bearer Number.

LBN: Logical Bearer Number.

up/down/sm/ss: indicates the type of connection.

Table 7.31

Up/down/sm/ss		Meaning
a ₂₄	a ₂₅	
0	0	Asymmetric uplink connection
0	1	Asymmetric downlink connection
1	0	Symmetric multibearer connection
1	1	Symmetric single bearer connection

Ser type and ser type/max life: this is a combined indicator of 6 bits that defines the MAC service type and the maximum lifetime parameter if the Service uses MAC MOD-2 protected operation.

Table 7.32

ser type			ser type/max life			Service type
a ₂₆	a ₂₇	a ₂₈	a ₂₉	a ₃₀	a ₃₁	
0	0	0	0	0	0	I _N _minimum_delay (I _{NA})
0	0	0	0	0	1	I _{PX} _encoded_protected
0	0	0	0	1	0	I _N _normal_delay (I _{NB})
0	0	0	1	0	0	unknown
0	0	0	1	0	1	C channel only
0	0	1	0	0	0	reserved (see note)
0	1	0	0	0	0	I _P _error_detection (I _{PM})
0	1	0	1	0	0	I _{PQ} _error_detection (I _{PQ})
0	1	1	L	L	L	I _P , MAC modulo-2 error correction (I _{PMR})
1	0	0	0	0	0	reserved (see note)
1	0	1	0	0	0	reserved (see note)
1	1	0	0	0	0	reserved (see note)
1	1	1	L	L	L	I _{PQ} MAC modulo 2 error correction (I _{PQR})
All other values						reserved
LLL = Maximum lifetime, see table 7.32a						
NOTE: See clause K.1 for historic use of some MAC service codes.						

- **Maximum packet lifetime:** For MAC MOD-2 protected services, the 3 last bits (a₂₉ a₃₀ a₃₁) carry the MAC maximum lifetime parameter (i.e. the latest possible retransmission). It can be 1 to 7 TDMA frames. The value 1 indicates that only one transmission is allowed. Values 2 to 7 indicate that the packet may be retransmitted until frame (n + v - 1), where n is the frame when the packet was transmitted by first time and v the received parameter; "0" = 000 indicates infinite lifetime is set, i.e. retransmit until received without error.
- It is possible to operate with separate MAC maximum packet lifetimes at TBC and at overall MAC level. See clause 10.8.2.2.1 in the present document. When this option is used, the overall MAC packet lifetime is generally set with the IE <<TRANSIT DELAY>> (see EN 300 175-5 [5], clause 7.7.42) and the value set by the Attributes message shall be understood as the TBC packet lifetime (maximum allowable lifetime of the packet in the same bearer).

Table 7.32a

Ser type/max life for MAC MOD-2 protected services			Meaning
a ₂₉	a ₃₀	a ₃₁	
0	0	0	no lifetime is set
all other values			Maximum lifetime

slot type: indicates the slot used by the connection.

Table 7.33

Slot type				Meaning
0	0	0	0	normal full slot
0	0	0	1	half slot (j=80)
0	0	1	1	long slot with j=640
0	1	0	0	long slot with j=672
0	0	1	0	double slot
all others				reserved

NOTE 1: If the slot type or j value is not implementable at the destination, a release is sent, preferably with the "reasons for release" field completed.

C_F : indicates if channel C_F is supported.

Table 7.33a

C_F	Meaning
0	this endpoint does not support C_F transmission
1	this endpoint does support C_F transmission

A-field mod type: indicates the modulation type used in A-field.

Table 7.34

A field modulation type		Meaning
a_{44}	a_{45}	
1	1	2-level modulation
1	0	4-level modulation
0	1	8-level modulation
0	0	reserved

(B+Z) fields mod type: indicates the modulation type used in B+Z fields.

Table 7.35

(B+Z) fields modulation type		Meaning
a_{46}	a_{47}	
1	1	2-level modulation
1	0	4-level modulation
0	1	8-level modulation
0	0	bits a_{37} to a_{43} are used to indicate the adaptive code rate and the extended modulation scheme (see note)

NOTE: Extended modulation and adaptive code rates are defined in annex I.

(B+Z) fields extended mod type: indicates the modulation type used in B+Z fields if (B+Z) fields mod type is coded as "00".

Table 7.35a

(B+Z) fields extended modulation type			Meaning
a_{37}	a_{38}	a_{39}	
0	0	0	reserved
0	0	1	16-level modulation
0	1	0	reserved
0	1	1	64-level modulation
all other values			reserved

Adaptive code rate: indicates the value of the r parameter (code rate) in encoded protected service.

Table 7.35b

Adaptive code rates for extended modulation				Meaning
a ₄₀	a ₄₁	a ₄₂	a ₄₃	
0	0	0	0	1,0 (no coding)
0	0	0	1	reserved
0	0	1	0	1/3
0	0	1	1	reserved
0	1	0	0	0,4
0	1	0	1	reserved
0	1	1	0	0,5
0	1	1	1	reserved
1	0	0	0	0,6
1	0	0	1	reserved
1	0	1	0	reserved
1	0	1	1	0,75
1	1	0	0	0,8
1	1	0	1	reserved
1	1	1	0	reserved
1	1	1	1	reserved

NOTE 2: The definition of fields given in this clause is re-used in many other messages. It should be taken into account that the position of the bits used for each field may be different. The bit numbers used for each field are indicated in the figure defining the structure of each message.

7.2.5.3.9 BANDWIDTH_T_{Req;Cfm}

0 0 0 1		1 0 0 0		R / C	0 0 0 (spare)		M _{Up}	0 0 0 (spare)		T _{Up}	0 0 0 (spare)		M _{Down}	0 0 0 (spare)		T _{Down}			
a ₈	a ₁₁	a ₁₂	a ₁₅	a ₁₆	a ₁₈	a ₁₉	a ₂₃	a ₂₄	a ₂₆	a ₂₇	a ₃₁	a ₃₂	a ₃₄	a ₃₅	a ₃₉	a ₄₀	a ₄₂	a ₄₃	a ₄₇

NOTE: This message is not needed for symmetric single duplex bearer connections.

R/C: See clause 7.2.5.3.8.

M_{Up}, M_{Down}: These are the minimum numbers of simplex bearers required by the DLC in, respectively, the PT to FT and the FT to PT directions.

T_{Up}, T_{Down}: These are the target numbers of simplex bearers in, respectively, the PT to FT and the FT to PT directions.

Figure 7.41

7.2.5.3.10 Channel_list

0 0 0 1		1 0 1 0		RPN	command and channel description				spare			
a ₈	a ₁₁	a ₁₂	a ₁₅	a ₁₆	a ₂₃	a ₂₄	a ₂₅	a ₂₆	a ₂₇	a ₃₉	a ₄₀	a ₄₇

Figure 7.42

command and channel description				
command	S / D	SN	SP	CN
c ₀	c ₂	c ₃	c ₄	c ₇
			c ₈	c ₉
				c ₁₀
				c ₁₅

Figure 7.43

Table 7.36

Command field			Message type
0	0	0	ACTIVE
0	0	1	GOOD
0	1	0	POOR
0	1	1	F/S_NOT
1	0	0	QUERY_N
1	0	1	QUERY_H
1	1	0	LISTEN
1	1	1	START
NOTE: The meanings of these message types are described in clause 10.5.2.			

For all messages except the F/S_NOT channel list message:

- S/D = 0:double simplex bearer; or
- S/D = 1:duplex bearer.

NOTE: The direction of asymmetry, and slot type are contained in the MAC_attributes messages or in the B-field bearer request message.

For the F/S_NOT message:

- S/D = 0:carrier "CN" not supported (no setup on this carrier);
- S/D = 1:blind slot pair "SP" (no setup on this slot pair).

The coding of SP, SN, and CN are the same as in the static system information described in clause 7.2.3.2.

7.2.5.3.11 Unconfirmed_dummy

0	0	0	1	1	0	1	1	FMID		PMID	
a ₈			a ₁₁	a ₁₂			a ₁₅	a ₁₆	a ₂₇	a ₂₈	a ₄₇

Figure 7.44

7.2.5.3.12 Unconfirmed_handover

0	0	0	1	1	1	0	0	FMID		PMID	
a ₈			a ₁₁	a ₁₂			a ₁₅	a ₁₆	a ₂₇	a ₂₈	a ₄₇

Figure 7.45

7.2.5.3.13 RELEASE

							Info 1 or spare		LBN		reason		PMID		
0	0	0	1	1	1	1	0	0	0	0					
a ₈						a ₁₅	a ₁₆		a ₁₉	a ₂₀	a ₂₃	a ₂₄	a ₂₇	a ₂₈	a ₄₇

NOTE: LBN refers to the bearer that is to be released. This message can be sent on a different bearer of the same connection to the one that is to be released.

Figure 7.46

Table 7.37

Reason				Reason for release
a ₂₄	a ₂₅	a ₂₆	a ₂₇	
0	0	0	0	unknown
0	0	0	1	bearer release (reduce capacity)
0	0	1	0	connection release
0	0	1	1	bearer setup or handover failed
0	1	0	0	bearer handover successfully completed
0	1	0	1	attempted bearer HO to another cluster
0	1	1	0	timeout, loss of signal
0	1	1	1	timeout, loss of handshake
1	0	0	0	requested unacceptable slot type
1	0	0	1	requested unacceptable MAC service
1	0	1	0	base station busy
1	0	1	1	reverse direction (double simplex)
1	1	0	0	duplicate PMID
1	1	0	1	unacceptable PMID
1	1	1	0	stay on listen for fast setup mode
1	1	1	1	reserved

NOTE: "bearer handover successfully completed" is only intended for use in some double simplex release.

The reason code "stay on listen for fast setup mode" is for FT use only. In that case the field info 1 carries additional information on the listen for setup mode (see table 7.37a).

Table 7.37a

Reason code a ₂₄ a ₂₇	info 1 a ₁₆ a ₁₉	meaning
"1110" stay on listen for setup mode	1111	Stay on complete listen for fast setup mode (all downlink slots), fast setup scan sequence
	SN (slot number)	Stay on selective listen for fast setup mode on slot SN (SEL1 mode), on fast setup scan sequence
any other reason code	0000	Spare field

The field info 1 is only used if the reason code is "stay on listen for fast setup mode". Otherwise it is a spare field filled.

7.2.5.4 MAC layer test messages

Refer to clause 12 for procedures.

7.2.5.4.1 Basic format

The basic format of the test message is given in figure 7.47.

0	0	1	0	test	data field
a ₈	a ₁₁	a ₁₂	a ₁₅	a ₁₆	a ₄₇

Figure 7.47: MAC layer test message format

Table 7.38

test				test mode
0	0	0	0	FORCE_TRANSMIT
0	0	0	1	LOOPBACK
0	0	1	0	DEFEAT_ANTENNA_DIVERSITY
0	0	1	1	reserved
0	1	0	0	ESCAPE
0	1	0	1	NETWORK_TEST
0	1	1	0	CHANGE_MODULATION_SCHEME
0	1	1	1	}
to				} reserved
1	1	1	0	}
1	1	1	1	CLEAR_TEST_MODES

If more than one test message of the type test = 0000, but with a different data field is received, then the IUT shall implement the most recently received message.

7.2.5.4.2 FORCE_TRANSMIT

This message forces the IUT to transmit on a specific slot and RF frequency. Handover is prohibited by means of the "Handover Disable" (HD) bit. The particular slot the IUT shall transmit on is indicated in the Slot Number (SN) field of the test message. The destination RF carrier is encoded in the Carrier Number (CN) field of the test message.

The format of the FORCE_TRANSMIT test message is given in figure 7.48.

0 0 1 0		0 0 0 0		spare				K	H	spare		SN	SP	CN	spare			
a ₈	a ₁₁	a ₁₂	a ₁₅	a ₁₆			a ₂₂	P	D	a ₂₅	a ₂₇	a ₂₈	a ₃₂	a ₃₄	a ₄₀			a ₄₇
												a ₃₁	a ₃₃	a ₃₉				

Figure 7.48: FORCE_TRANSMIT test message format

The KP bit is a₂₃. It is set to "1" to prevent release of existing bearers, and set to "0" to initiate releasing of existing bearers.

The HD bit is a₂₄. It is set to "1" to disable handover and set to "0" otherwise.

For the coding of the slot number, the start position, and the carrier number refer to clause 7.2.3.2.

See clause 12.3 for the relevant procedures.

7.2.5.4.3 LOOPBACK_DATA

This message instructs the IUT to perform the loopback function in which a test data pattern transmitted by the LT is replicated in the reply transmission of the IUT. The test data pattern is a bit sequence located in the D-fields of the LT and IUT. The bits of the D-field that are affected by the loopback function depend on the equipment type and are given in table 7.39.

Table 7.39: LOOPBACK_DATA bits

DECT Implementation	Loopback bits
Transmits only A-field	a ₁₆ to a ₄₇
Transmits half-slots	b ₀ to b ₇₉
Transmits long -slots (j=640)	b ₀ to b ₆₃₉
Transmits long -slots (j=672)	b ₀ to b ₆₇₁
Transmits full-slots	b ₀ to b ₃₁₉
Transmits double-slots	b ₀ to b ₇₉₉

Equipment capable of transmitting more than one slot type shall use the longest slot type.

For A-field loopback, the format of the LOOPBACK_DATA test message is given in figure 7.49.

0 0 1 0		0 0 0 1		Loopback data (A-field)									
XXXX		XXXX		XXXX		XXXX		XXXX		XXXX		XXXX	
a ₈	a ₁₁	a ₁₂	a ₁₅	a ₁₆									a ₄₇

NOTE: "X" is the data looped back to the tester.

Figure 7.49: LOOPBACK_DATA test message, A-field

For B-field loopback, the format of the LOOPBACK_DATA test message is given in figure 7.50.

0 0 1 0		0 0 0 1		spare											
0000		1111		0000		1111		0000		1111		0000		1111	
a ₈	a ₁₁	a ₁₂	a ₁₅	a ₁₆											a ₄₇

Figure 7.50: LOOPBACK_DATA test message, B-field

See clause 12.4 for the relevant procedures.

7.2.5.4.4 DEFEAT_ANTENNA_DIVERSITY

This message inhibits antenna diversity operation in the IUT and selects an antenna. The antennas shall be numbered 0 to N where (N + 1) is the number of antennas employed in the antenna diversity operation. The numbering of antennas shall be done by the manufacturer.

IUTs with no antenna diversity shall ignore this message.

IUTs receiving this message with an ANT > N shall ignore this message.

The IUT remains in this mode until the test message "CLEAR_TEST_MODES" is received.

The format of the DEFEAT_ANTENNA_DIVERSITY test message is given in figure 7.51.

0 0 1 0		0 0 1 0		S	ANT	spare									
1111		0000		P	ANT	1111		0000		1111		0000		1111	
a ₈	a ₁₁	a ₁₂	a ₁₅	a ₁₆	a ₁₉	a ₂₀									a ₄₇

NOTE: SP = spare bit = 0.

Figure 7.51: DEFEAT_ANTENNA_DIVERSITY test message

Table 7.40 details the encoding of the ANT bit.

Table 7.40: ANT bit

ANT			Antenna number
a ₁₇	a ₁₈	a ₁₉	
0	0	0	0
0	0	1	1
0	1	0	2
0	1	1	3
1	0	0	4
1	0	1	5
1	1	0	6
1	1	1	7

See clause 12.5 for the relevant procedures.

7.2.5.4.5 ESCAPE

The transmission of this message to the IUT indicates that the data in the test data field is a proprietary test message. Every transmission of a proprietary test message shall be preceded by the "escape" message. The format of the ESCAPE message is given in figure 7.52.

0 0 1 0				0 1 0 0				proprietary test message							
XXXX				XXXX				XXXX				XXXX			
a ₈	a ₁₁	a ₁₂	a ₁₅	a ₁₆										a ₄₇	

Figure 7.52: ESCAPE message

See clause 12.7 for the relevant procedure.

7.2.5.4.6 NETWORK_TEST

The lower layer management entity in the testing unit supplies the MAC layer with a 32 bit SDU via the ME SAP. At the unit under test, the MAC layer passes the 32 bit test message out through the ME SAP to the lower layer management entity. See EN 300 175-5 [5].

The format of the NETWORK_TEST message is given in figure 7.53.

0 0 1 0				0 1 0 1				test message							
XXXX				XXXX				XXXX				XXXX			
a ₈	a ₁₁	a ₁₂	a ₁₅	a ₁₆										a ₄₇	

Figure 7.53: NETWORK_TEST message

See clause 12.6 for the relevant procedure.

7.2.5.4.7 CLEAR_TEST_MODES

The receipt of this message shall clear all current test modes (including proprietary) within 16 frames and return the IUT to the test standby mode.

The format of the CLEAR_TEST_MODES message is given in figure 7.54.

0 0 1 0				1 1 1 1				spare							
0000				1111				0000				1111			
a ₈	a ₁₁	a ₁₂	a ₁₅	a ₁₆										a ₄₇	

Figure 7.54: CLEAR_TEST_MODES

See clause 12.8 for the relevant procedure.

7.2.5.4.8 CHANGE_MODULATION_SCHEME

This test message is received by IUTs that declare 4-level, 8-level, 16-level or 64-level modulation capability. It causes the IUT to switch to the requested modulation scheme if this requested modulation scheme is supported by the IUT.

The format of the CHANGE_MODULATION_SCHEME message is given in figure 7.55.

0 0 1 0				0 1 1 0				S	P	SCH	spare								
1111				0000				1111				0000				1111			
a ₈	a ₁₁	a ₁₂	a ₁₅	a ₁₆	a ₁₉	a ₂₀											a ₄₇		

NOTE: a₁₆ = SP = spare bit = 0.

Figure 7.55: CHANGE_MODULATION_SCHEME

Table 7.41 details the encoding of the SCH bit.

Table 7.41: SCH bit

SCH			Modulation scheme
a ₁₇	a ₁₈	a ₁₉	
0	0	0	1a
0	0	1	1b
0	1	0	2
0	1	1	3
1	0	0	4a
1	0	1	4b
1	1	0	5
1	1	1	6

For definition of the modulation schemes see annex D of EN 300 175-2 [2].

See clause 12.9 for the relevant procedure.

7.2.5.5 Quality control

0	0	1	1	command	param_1	param_2	0000	1111	0000	1111	
a ₈					a ₁₅	a ₁₆	a ₂₃	a ₂₄	a ₃₁	a ₃₂	a ₄₇

Figure 7.56

Table 7.42

command	param_1	param_2	Meaning
0000	LBN LBN	LBN LBN	antenna switch for the bearer(s) identified by LBN request: PT --> FT reject: FT --> PT
0001	RPN	0000 1111	antenna switch for all bearers of this connection to the RFP identified by its RPN request: PT --> FT reject: FT --> PT
0010	0000 LBN	0000 0000 or RPN	bearer handover/bearer replacement of the bearer identified by LBN request: FT --> PT reject: PT --> FT
0010	1111 LBN	0000 0000 or RPN	bearer handover/bearer replacement of the bearer identified by LBN request: PT --> FT reject: FT --> PT
0011	0000 1111	0000 1111	connection handover request: FT --> PT reject: PT --> FT
0100	0000 LBN	frequency error	frequency control for the bearer identified by LBN request: FT --> PT reject: PT --> FT
0101	RPN	frequency error	frequency control for all bearers of this connection to the RFP identified by its RPN request: FT --> PT reject: PT --> FT
0110	RPN	advance timing increment decrement	Advance timing for all the bearers of this connection to the RFP identified by its RPN request: FT --> PT reject: PT --> FT
0111	RPN	0000 1111	PT --> FT: PT informs that it is transmitting prolonged preamble in all the frames
1000	0000 SN	0000 CN	frequency replacement to carrier CN on slot pair SN request PT -> FT confirm FT -> PT

command	param_1	param_2	Meaning
1000	0001 SN	0000 CN	frequency replacement to carrier CN on slot pair SN grant PT -> FT
1001			
to			reserved
1111			
<p>NOTE 1: The function of these commands depends on the transmission direction. The commands are either requests or rejects. A reject should only be used if the requested action is not supported.</p> <p>NOTE 2: For basic connections LBN is set to 1111.</p> <p>NOTE 3: All other values for bits a_{16} to a_{47} inclusive are reserved. Potential uses include RSSI reporting, synchronization word correlation report, clock jitter report, etc.</p> <p>NOTE 4: For the bearer handover request, the RPN is an optional parameter. If set to all "0" the FP does not propose a particular RFP for handover.</p> <p>NOTE 5: A PP may or may not accept the RFP's proposal of the new RPN.</p> <p>NOTE 6: The frequency error in kHz is encoded in 2's complement form, to give a range of +127 kHz to -128 kHz. The LSB of the error is placed in bit position a_{31}.</p> <p>NOTE 7: The advance timing changes are encoded in 2's complement form (+127 bits to -128 bits). The LSB of the advance timing is placed in position a_{31}. Changes with less than 2 bits should not be requested.</p> <p>NOTE 8: The bearer handover request command in the PT to FT direction is used in the double simplex bearer handover procedure.</p>			

7.2.5.5.1 Prolonged preamble diversity

7.2.5.5.1.1 Procedure for prolonged preamble diversity in RFP

This procedure applies to RFPs that use the prolonged preamble for diversity. The procedure secures that the prolonged preamble is transmitted only by the PP if it knows that the RFP uses it for diversity. The PP shall not transmit the prolonged preamble if the synchronization field options in the extended fixed part capabilities indicates standard synchronization field (see clause 7.2.3.5.2.2).

The RFP shall indicate the support for prolonged preamble in the extended fixed part capabilities only in case it is capable of using a prolonged preamble.

- 1) Immediately after the bearer setup procedure, the PP informs the RFP that it sends the prolonged preamble. This indicates that the RFP can use the prolonged preamble for diversity (see clauses 7.2.5.5 and 7.3.5.2). Repeats of this request are allowed.

NOTE 1: The bearer setup procedure above also relates to handover.

NOTE 2: Bearer setup procedure ends when the initiating side receives the "other"- message.

- 2) All PP transmissions following the information message shall contain the prolonged preamble. The PP may send the prolonged preamble immediately after it has transmitted the prolonged preamble indication or it may transmit the prolonged preamble from the bearer request onwards.

7.2.5.5.1.2 Procedure for prolonged preamble diversity in PP

This procedure applies to PPs that use the prolonged preamble for diversity. The procedure secures that the prolonged preamble is not transmitted by the RFP if the synchronization field options in the extended fixed part capabilities indicates standard synchronization field (see clause 7.2.3.5.2.2).

- 1) The RFP shall transmit a prolonged preamble for automatic antenna selection by the PP if and only if it indicates the support for prolonged preamble in the extended fixed part capabilities.
- 2) The PP does not need to take further control actions, it can enable automatic antenna selection based on prolonged preamble as long as the extended fixed part capabilities indicate the support of this feature.

7.2.5.6 Broadcast and connectionless services

0	1	0	0	a	b	c	d	FMID	PMID
a ₈							a ₁₅	a ₁₆	a ₂₇
								a ₂₈	a ₄₇

Figure 7.57

Table 7.43

a	b	c	d	Meaning
0	0	0	0	CL _F , first of 2 transmissions, half slot
0	0	0	1	CL _F , first of 2 transmissions, full slot
0	0	1	0	CL _F , first of 2 transmissions, double slot
0	0	1	1	CL _F , first of 2 transmissions, long slot (j=640)
0	1	0	0	CL _F , last transmission, half slot
0	1	0	1	CL _F , last transmission, full slot
0	1	1	0	CL _F , last transmission, double slot
0	1	1	1	CL _F , last transmission, long slot (j=640)
1	0	0	0	C/L single transmission, no CL _F or CL _S service
1	0	0	1	CL _F service, first transmission
1	0	1	0	Reserved
1	0	1	1	Reserved
1	1	0	0	change dummy bearer position
1	1	0	1	Reserved
1	1	1	0	Extended System Information; A-field procedure
1	1	1	1	Extended System Information; B-field procedure

The "extended system information" messages are the only messages used in both directions. All other messages are sent only in direction PT to FT.

Connectionless single transmission uplink services:

abcd = 01xx: CL_F service;

abcd = 1000: PMID exchange (no CL channel data).

Connectionless double transmission uplink services:

abcd = 00xx followed by abcd = 01xx: CL_F service;

abcd = 1001 followed by a C_T tail: CL_S service.

Non-continuous broadcast services:

abcd = 1100: change dummy bearer position;

abcd = 111x: extended system information: this message shall be used for requests and replies of extended system information (see clause 9.3.1).

7.2.5.7 Encryption control

0	1	0	1	command	FMID	PMID
a ₈				a ₁₁	a ₁₂	a ₁₅
					a ₁₆	a ₂₇
						a ₂₈
						a ₄₇

Figure 7.58

Table 7.44

Command				Message
0	0	x	x	start encryption
0	1	x	x	stop encryption
1	0	x	x	start encryption with cipher key-index (see note)
1	1	x	x	reserved
x	x	0	0	request
x	x	0	1	confirm
x	x	1	0	grant
x	x	1	1	reserved

NOTE: See figure 7.58a, tables 7.44a and 7.44b.

0	1	0	1	command	Key-Index (see table 7.44b)	Reserved (see note)
a ₈	a ₁₁	1	0	x x	a ₁₆	a ₃₁ a ₃₂ a ₄₇

NOTE: Reserved bits shall be set to 0.

Figure 7.58a: Only for command=10xx

Table 7.44a: Start encryption with cipher key-index

Command				Message
1	0	0	0	start encryption with cipher key-index : request
1	0	0	1	start encryption with cipher key-index : confirm
1	0	1	0	start encryption with cipher key-index : grant
1	0	1	1	start encryption with cipher key-index : reject

Table 7.44b: Cipher key index

Key-Index	Meaning
0000 0000 0000 0000	no cipher key index
0000 0000 0000 0001 to 1111 1110 1111 1111	valid cipher key index
1111 1111 0000 0000 to 1111 1111 1111 1110	reserved
1111 1111 1111 1111	invalid cipher key index

7.2.5.8 B-field setup, first PT transmission

0	1	1	0	least significant 36 bits of RFPI
a ₈	a ₁₁	a ₁₂		a ₄₇

Figure 7.59

This message is intended to be use for first transmission on new physical channels and only by PT. See clause 10.5.1.7 for description about the use of this message.

7.2.5.9 Escape

0	1	1	1	escape information			
a ₈		a ₁₁	a ₁₂				a ₄₇

Figure 7.60

Any DECT equipment may transmit an escape message.

The content of the escape information field (a₃₆ to a₄₇) is not specified. This message is provided for application specific use.

7.2.5.10 TARI message

The message is assumed to be a "request" when transmitted in direction PT to FT, and to be a "reply" when transmitted in direction FT to PT.

1	0	0	0	TARI field			
a ₈		a ₁₁	a ₁₂				a ₄₇

Figure 7.61

The management entity in the transmitting radio endpoint supplies the MAC layer with a 36 bit SDU via the ME SAP. At the receiving endpoint the MAC layer passes the 36 bit SDU out through the ME SAP to the management entity.

For the coding of the TARI field refer to EN 300 175-6 [6].

7.2.5.11 REP connection control

7.2.5.11.1 General

The REP connection control messages shall be used to establish a duplex bearer and to create a double duplex bearer.

7.2.5.11.2 Format for most messages

1	0	0	1	command		FMID		PMID	
a ₈		a ₁₁	a ₁₂	a ₁₅	a ₁₆	a ₂₇	a ₂₈		a ₄₇

NOTE: For definitions of FMID and PMID, see clause 11.7.

Figure 7.62

Table 7.45

Command				REP connection control messages					
0	0	0	0	REP_access_request (see note)					
0	0	0	1	REP_bearer_handover_request (see note)					
0	1	0	0	REP_bearer_confirm					
0	1	0	1	REP_wait					
1	1	1	1	REP_release					
0	1	1	0	REP_channel_map_request					
0	1	1	1	REP_channel_map_confirm					
1	0	0	0	}					
to				} reserved					
1	1	1	1	}					
NOTE: Indicates messages that use the first "PT transmission" code. Other messages use the normal M _T code.									

For REP_channel_map.req and REP_channel_map.cfm messages the format is defined in figures 7.63 and 7.64.

7.2.5.11.3 REP CHANNEL MAP REQUEST

1	0	0	1	0	1	1	0	SN	CN	FMID	SN	CN
a ₈	a ₁₁	a ₁₂	a ₁₅	a ₁₆	a ₁₉	a ₂₀	a ₂₅	a ₂₆	a ₃₇	a ₃₈	a ₄₁	a ₄₇

Figure 7.63: REP_channel_map.req

7.2.5.11.4 REP CHANNEL MAP CONFIRM

1	0	0	1	0	1	1	1	SN	CN	A/R	spare 00011110000	SN	CN
a ₈	a ₁₁	a ₁₂	a ₁₅	a ₁₆	a ₁₉	a ₂₀	a ₂₅	a ₂₆	a ₂₇	a ₃₇	a ₃₈	a ₄₁	a ₄₇

Figure 7.64: REP_channel_map.cfm

The coding of SN and of CN is the same as in "static system information" described in clause 7.2.3.2. The A/R flag set to 1 means "Accepted", otherwise "Rejected".

7.2.5.12 Advanced connection control part 2

7.2.5.12.1 General

The advanced connection control messages part 2 extends the regular advanced connection control codes with some extra messages for packet mode operations. These messages are used by PPs and RFPs that are attempting to setup and resume packet mode connections with expedited operations.

NOTE: The expedited operations are optimized for low power consumption and are used by DECT ULE (see TS 102 939-1 [i.10]).

Table 7.45a: Advanced Connection Control Part 2

Command				Advanced connection control part 2 messages
0	0	0	0	expedited_access_request
0	0	0	1	expedited_access_request_ready_for_release
0	0	1	0	Null or G _{FA} channel transmission
0	0	1	1	}
to				} reserved
1	1	0	1	}
1	1	1	0	ready for release with G _{FA} transmission
1	1	1	1	expedited_release with G _{FA} transmission
NOTE: The codes for bearer_confirm is re-used from the regular advanced connection control set.				

7.2.5.12.1 Short description of the advanced connection control part 2 messages

The exact use of advanced connection control part 2 messages is described in the detailed procedure description for C/O bearer setup and release (see clauses 10.5.1.8 and 10.7.3).

The following text provides a short description of the meaning and intended use of the messages:

Expedited access request: this message is used for an expedited setup procedure of an already existing logical connection when the transmission has to continue in subsequent frames (multi-burst setup). It allows the transport of U-plane data together with the message. This message is normally acknowledged with a "bearer confirm" (advanced control set).

Expedited Access Request Ready for Release: this message is used for an expedited setup procedure of an already existing logical connection when there is only one frame for transmission from the originator side (single-burst setup). It is equivalent to the transmission of "expedited access request" plus "ready for release" in the same message. It allows the transport of U-plane data together with the message. This message is normally followed by a "expedited release" (see clause 10.5.1.8.2).

Null or G_{FA} channel transmission: It allows the transmission at any time of a G_{FA} channel packet (full format), or alternatively it may be used to transmit a 'null' message (instead of inserting a N_T channel tail)

Ready for Release: this message is used to indicate during an expedited connection, that the sending side does not have more data for transmission (last U-plane segment may be inserted in the same frame that carries the message) and therefore is ready to accept a release from the other peer.

Expedited Release: this message is used for releasing the bearer of an expedited connection. See clause 10.7.3 for procedures. Only the physical connection is released. The MBC is preserved and the connection passes to suspend state (see clauses 10.7.3 and 10.3.1.1).

7.2.5.12.3 Format for most advanced connection control part 2 messages

1	0	1	0	command	FMID	PMID
a_8		a_{11}		a_{12} a_{15}	a_{16} a_{27}	a_{28} a_{47}

NOTE: For definitions of FMID, PMID, see clause 11.7.

Figure 7.64a: Format of most Advanced Connection Control Part 2 Messages

7.2.5.12.4 Format for "ready for release with G_{FA} " and "expedited release with G_{FA} " messages

1	0	1	0	1	1	1	X	info	reason	G_{FA} RN	'X'PMID
a_8		a_{11}		a_{12}	a_{15}	a_{16}	a_{21}	a_{22} a_{27}	a_{28} a_{27}	a_{28} a_{35}	a_{36} a_{47}

NOTE 1: bit a_{15} is 1 for Expedited Release and 0 for Ready for Release (see table 7a.1).

NOTE 2: The 'X'PMID" is the shortened PMID (12 least significant bits). Refer to clause 11.7 for definition.

Figure 7.64b: Format of the "ready_for_release" and "expedited_release_with_ G_{FA} " messages

The meaning of the different fields is as follows:

'X'PMID: is the shortened PMID. Contains the 12 least significant bits of the PMID.

G_{FA} RN: provides transport for a G_{FA} channel packet, short format (frame FU10d, short format). It contains an 8 bit Received Sequence Number that should be understood as an ACK DLC command (refer to EN 300 175-4 [4] clause 12.11.1). The insertion of the G_{FA} RN is mandatory in this message. If there are no further DLC PDUs for ACK, last value may be repeated.

Info: this field is used with some reason codes providing additional information. The meaning depends on the reason code. When not used it shall be set to '000000'B.

Reason: indicates the reason for the release or ready for release. It is coded as shown in table 7a.2.

Table 7.45b: Coding of "reason" in "expedited release" and "ready for release" messages.

Reason						Meaning	Info field
a ₂₂	a ₂₃	a ₂₄	a ₂₅	a ₂₆	a ₂₇		
0	0	0	0	0	0	unknown	Not used, notes 4 and 5
0	0	0	0	0	1	Normal bearer release, see note 1	Not used, notes 4 and 5
0	0	0	0	1	0	connection release	Not used, notes 4 and 5
0	0	0	0	1	1	bearer setup or handover failed	Not used, notes 4 and 5
0	0	0	1	0	0	bearer handover successfully completed	Not used, notes 4 and 5
0	0	0	1	0	1	attempted bearer HO to another cluster	Not used, notes 4 and 5
0	0	0	1	1	0	timeout, loss of signal	Not used, notes 4 and 5
0	0	0	1	1	1	timeout, loss of handshake	Not used, notes 4 and 5
0	0	1	0	0	0	requested unacceptable slot type	Not used, notes 4 and 5
0	0	1	0	0	1	requested unacceptable MAC service	Not used, notes 4 and 5
0	0	1	0	1	0	base station busy	Not used, notes 4 and 5
0	0	1	0	1	1	reverse direction (double simplex)	Not used, notes 4 and 5
0	0	1	1	0	0	duplicate PMID	Not used, notes 4 and 5
0	0	1	1	0	1	unacceptable PMID / Unregistered PMID	Not used, notes 4 and 5
0	0	1	1	1	0	stay on listen for fast setup mode	Bits a ₁₆ - a ₁₉ coded as given in clause 7.2.5.3.13, table 7.37a. Notes 3 and 5
0	0	1	1	1	1	Stay in LCE paging detection mode	Code indicating paging mode and timer information, see clause 7.2.5.12.5.2 and note 3
0	1	0	0	0	0	switch to circuit mode	Code describing circuit mode action. Notes 3 and 5
0	1	0	0	0	1	Stay in higher paging detection mode	Code indicating paging mode and timer information, see clause 7.2.5.12.5.3 and note 3
0	1	0	0	1	0	setup again (request for new packet mode connection after n frames as in info field)	Code indicating number of frames for the setup attempt, note 3
0	1	0	0	1	1	wrong slot or service type	Not used, notes 4 and 5
0	1	0	1	0	0	No such connection / virtual circuit, note 2	Not used, notes 4 and 5
0	1	0	1	0	1	}	
to						}	reserved
1	1	1	1	1	1	}	
NOTE 1: This is the 'normal' release reason code for a release of packet mode connections.							
NOTE 2: This reason code shall be used as response to Expedited access requests attempts when there is no associated context (suspended MAC connection / suspended link / Virtual call) for the initiating PT.							
NOTE 2: The reason codes for "ready for release" and "expedited release" messages when bits a ₂₂ and a ₂₃ are set to 0 are identical to the codes for the regular advanced A-field release message:							
NOTE 3: Application profiles may further define the exact use of each reason code and the meaning of the info field.							
NOTE 4: Unless otherwise indicated by the application profile. Application profiles may define local uses for the info field.							
NOTE 5: Unused bits in 'info' field shall be set to '0'.							

7.2.5.12.5 Reason codes in "ready for release with G_{FA}" and "expedited release with G_{FA}" messages

The meaning of the following reason codes and the content of the field shall be understood as follows:

7.2.5.12.5.1 Reason code "stay on listen for fast setup mode "

This reason code is only defined when sent in the FP => PT direction. It indicates that the PT should switch to listening for direct FT setup (fast setup) detection state. The bits a₁₆ - a₁₉ in the info field shall be coded and have the meaning as given in clause 7.2.5.3.13, table 7.37a. Bits a₂₀ - a₂₁ are reserved and shall be coded to '0'.

7.2.5.12.5.2 Reason code "Stay in LCE paging detection mode"

This reason code is only defined when sent in the FT => PT direction. It indicates that the PT should be in listening for LCE paging (in A-field) mode until the expiration of a given timer. The bits a_{16} - a_{19} in the info field indicates the paging mode and the timer and shall be coded as follows:

Table 7.45c: info field for Reason code "Stay in LCE paging detection mode"

Bit a_{16}	meaning	Meaning of bits a_{17} to a_{21}	remarks
0	Stay in listening for LCE paging state with normal duty cycle until LCE paging is received or expiration of timer	Timer in Multiframe (max 31 MF)	
1	Stay in listening for LCE paging state with high duty cycle until LCE paging is received or expiration of timer	Timer in frames (max 31 frames)	

7.2.5.12.5.3 Reason code "Stay in higher paging detection mode"

This reason code is only defined when sent in the FT => PT direction. It indicates that the PT should switch to a different duty cycle of B-field paging detection. Two possible alternative duty cycles may be defined. The definition of the parameters of the alternative duty cycles shall be done with the same NWK layer IE used to define the primary duty cycle.

The bit a_{16} in the info field indicates the alternative duty cycle. The bits a_{17} - a_{19} in the same info field indicates the timer, measured in paging cycles of the specified paging schema, without taking into account redundant transmissions, after which the PT shall move to the primary paging detection schema.

EXAMPLE: if primary paging cycle specifies a cycle of one paging per 256 multiframe and the alternative paging specifies a cycle of one paging per 4 multiframe, a value of the timer '01000'B should be understood as $8 \times 4 \times 16 = 256$ frames.

NOTE: Alternative duty cycles are expected to be higher (faster) than primary duty cycle.

Table 7.45d: info field for Reason code "Stay in higher paging detection mode"

bit a_{16}	meaning	Meaning of bits a_{17} to a_{21}	remarks
0	Listen to ULE paging with the highest possible duty cycle specified in the paging descriptor(s).	Timer in paging cycles of the paging descriptor (in paging cycles of the fastest descriptor if more than one has been allocated).	
1	Reserved for further standardization	Reserved	

7.2.5.12.5.4 Reason code "Setup again"

This reason code is only defined when sent in the FP => PT direction. Indicates the PT should wait the time specified in the info field and try again the setup attempt.

The bits a_{17} - a_{21} in the info field indicates the timer, measured in frames, after which the PT shall send again an expedited access request or expedited access request ready for release message. The standard rules for channel selection shall apply. The maximum value is 31 frames.

The bit a_{16} is reserved and shall be set to '0'.

7.2.5.12.6 Format for "Null or G_{FA}channel transmission" message

The command code '0010' is used for a "null or G_{FA}channel transmission" message, which contains a 2 bit "op-code" in bits a_{26} - a_{27} , and an "info field" in bits a_{16} - a_{25} . Currently only "null" and "G_{FA}channel transmission" are defined.

1	0	1	0	0	0	1	0	Info	Op code	PMID
a_8	a_{11}	a_{12}	a_{15}	a_{16}	a_{25}	a_{26}	a_{27}	a_{28}	a_{47}	

Figure 7.64c: Format of the "Null or G_{FA}channel transmission" message

Definition of op-codes:

Table 7.45e: Coding of Op-codes in "Null or G_{FA}channel transmission" message

Op-code (a_{26} - a_{27})		Description
0	0	null
0	1	G _{FA} channel
1	0	reserved
1	1	reserved

For op-code '00' ('null') the info field (bits a_{16} - a_{25}) shall be all coded as '0000000000'B.

For op-code '01' ('G_{FA}channel transmission'), the info field (bits a_{16} - a_{25}) transports a FU10d frame, full format (see clause 12.11.1 in EN 300 175-4 [4] with the following bitmap:

Table 7.45f: Coding of info field for Op-code "G_{FA}channel transmission"

a_{16} - a_{23}	a_{24}	a_{25}
8 bits of RN	9 th bit of RN	ACK/NACK

The FU10d frame, full format may be used to transport either an ACK or a NACK command (refer to EN 300 175-4 [4], clause 12.11.1).

NOTE: The 8 bit RN is stored in bits a_{16} - a_{23} , this aligns with its use in the expedited release message; bit a_{16} is the most significant bit of the RN. Bit a_{24} is used for the 9th bit of RN in the case that 9 bit RNs are used. Bit a_{25} allows the possibility of ACK/NACK, the value 1 means that the RN refers to an ACK, and the value 0 means that the RN refers to a NACK.

7.3 Messages in the B-field

7.3.1 Overview

Messages may be carried in the B-field only when operating in the E-type or E+U type multiplexers (see clause 6.2.2.2). Each B-field message occupies one subfield, and different subfields will usually carry a different message. The possible arrangements of B-field messages are defined by the E/U-MUX algorithm defined in clauses 6.2.2.3 and 6.2.2.4.

All B-field messages have a fixed length of 64 bits.

MAC B-field messages are used to:

- 1) set-up, maintain and release bearers and connections;
- 2) provide extra flow, error and quality control in symmetric connections;
- 3) carry G_F channel data;
- 4) transport extended system information and TARI information;
- 5) exchange information about I_{PF} channel segmentation in E+U type mux; and
- 6) fill the B-field if there are insufficient C_F , G_F , or I_{PF} segments to fill the whole of the B-field.

A M_{Bn} message is a B-field MAC layer control message sent in the B_n subfield. M_{Bn} messages are sent in 80 bit packets using the E mapping described in clause 6.2.2.2. This allows M_{Bn} messages to be compatible across all types of packets. Within the 80 bits, the format is as given in figure 7.65.

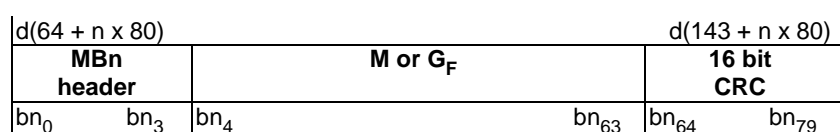

Figure 7.65: B-field messages

"n" denotes the number of the subfield in the B-field. For the D08 field, n = 0, while for the D32 field n={0,1,2,3}. The CRC calculation is described in clause 6.2.5.2.

The M_{Bn} header defines whether the message contains M or G_F channel data and whether another M_{Bn} message follows in the next B_n subfield. In a full-slot transmission, up to 4 messages can be sent in the B-field.

Table 7.46

MBn header				Message type
bn ₀			bn ₃	
X	0	0	0	reserved
X	0	0	1	advanced connection control
X	0	1	0	Null or I_{PF} segmentation information
X	0	1	1	quality control
X	1	0	0	extended system information
X	1	0	1	G_F channel data packet
X	1	1	0	reserved
X	1	1	1	escape

The meaning of the MSB bit of the MB_n header (bn₀) is the following:

For half slot 2-level modulation:

X = 1: the bit shall be set to "1" in all cases.

For all other slot types and modulation levels:

- For E+U type mux (B-field identification, BA=110 or BA=111, see clause 7.1.4):

X = 1: subfield B(n + 1) exists and contains a M_{Bn} or G_F message, or subfield B(n) is the last subfield in this slot;

X = 0: subfields B(n + 1) and all following in this slot contain I_{PF} (or SI_{PF}) segments.

- For E-type mux (B-field identification, BA=100 or BA=101, see clause 7.1.4):
 - X = 1: subfield B(n + 1) exists and contains a M_{Bn} or G_F message, or subfield B(n) is the last subfield in this slot;
 - X = 0: subfields B(n + 1) and all following in this slot contain C_F or CL_F segments.

NOTE: There are no MBn headers in E-type-all- C_F mux mode (BA=010 or BA=011).

7.3.2 Advanced connection control

7.3.2.1 General format

X	0	0	1	command	information
bn_0	bn_3	bn_4	bn_7	bn_8	bn_{63}

Figure 7.66

Table 7.47

Command				Advanced connection control messages
0	0	0	0	ACCESS_REQUEST (see note)
0	0	0	1	bearer_handover_request (see note)
0	0	1	0	connection_handover_request (see note)
0	0	1	1	unconfirmed_access_request (see note)
0	1	0	0	bearer_confirm
0	1	0	1	wait
0	1	1	0	attributes_B_request
0	1	1	1	attributes_B_confirm
1	0	0	0	bandwidth_B_request
1	0	0	1	bandwidth_B_confirm
1	0	1	0	channel_list
1	0	1	1	unconfirmed_dummy (see note)
1	1	0	0	unconfirmed_handover (see note)
1	1	0	1	reserved
1	1	1	0	reserved
1	1	1	1	release

NOTE: Indicates messages, that if transmitted by a PT, use the "first PT transmission" code.
The FT may use the messages indicated with NOTE without the "first PT transmission" code.

7.3.2.2 BEARER_REQUEST

X	0	0	1	0	0	I/B/C/N	FMID	PMID	ECN	LBN	up/down/sm/ss	ser type	ser type/max life	slot type	A-field mod. type	(B+Z) fields mod. type
bn_0						bn_6 bn_7	bn_8 bn_{19}	bn_{20} bn_{39}	bn_{40} bn_{43}	bn_{44} bn_{47}	bn_{48} bn_{49}	bn_{50} bn_{52}	bn_{53} bn_{55}	bn_{56} bn_{59}	bn_{60} bn_{61}	bn_{62} bn_{63}

Figure 7.67

Table 7.48

I/B/C/N		Meaning
b_6	b_7	
0	0	access_request
0	1	bearer_handover_request
1	0	connection_handover_request
1	1	unconfirmed_access_request

For the coding of bits b_{40} to b_{63} , see clause 7.2.5.3.8.

- PMID = Portable part MAC layer IDentity (see clause 11.7);
- FMID = Fixed part MAC layer IDentity (see clause 11.7).

7.3.2.3 BEARER_CONFIRM

X 0 0 1 0 1 0 0	FMID	PMID	ECN	LBN	up/down/	ser type	ser type/ max life	slot type	A-field mod type	(B+Z) field mod. type
b_{n_0}	b_{n_8} b_{n_7} $b_{n_{19}}$	$b_{n_{20}}$ $b_{n_{39}}$	$b_{n_{40}}$ $b_{n_{43}}$	$b_{n_{44}}$ $b_{n_{47}}$	$b_{n_{48}}$ $b_{n_{49}}$	$b_{n_{50}}$ $b_{n_{52}}$	$b_{n_{53}}$ $b_{n_{55}}$	$b_{n_{56}}$ $b_{n_{59}}$	$b_{n_{60}}$ $b_{n_{61}}$	$b_{n_{62}}$ $b_{n_{63}}$

Figure 7.68

For the coding of bits b_{40} to b_{63} , see clause 7.2.5.3.8.

7.3.2.4 WAIT

X 0 0 1 0 1 0 1	FMID	PMID or spare 11110000111100001111	spare 00001111 00001111
b_{n_0}	b_{n_8} b_{n_7} $b_{n_{19}}$	$b_{n_{20}}$ $b_{n_{39}}$	$b_{n_{40}}$ $b_{n_{63}}$

NOTE: The procedure does not make reference to the values of b_{n_8} to $b_{n_{63}}$. It is not intended that the contents of this field be included in any mandatory tests.

Figure 7.69

7.3.2.5 ATTRIBUTES_B_{Req;Cfm}

X 0 0 1 0 1 1	R / C	FMID	PMID	(B+Z) fields ext. mod. type	adaptive code rate for ext. mod.	up/down/ sm/ss	ser type	max life	slot type	A-field mod. type	(B+Z) fields mod. type
b_{n_0}	b_{n_7} b_{n_6}	b_{n_8} $b_{n_{19}}$	$b_{n_{20}}$ $b_{n_{39}}$	$b_{n_{40}}$ $b_{n_{43}}$	$b_{n_{44}}$ $b_{n_{47}}$	$b_{n_{48}}$ $b_{n_{49}}$	$b_{n_{50}}$ $b_{n_{52}}$	$b_{n_{53}}$ $b_{n_{55}}$	$b_{n_{56}}$ $b_{n_{59}}$	$b_{n_{60}}$ $b_{n_{61}}$	$b_{n_{62}}$ $b_{n_{63}}$

NOTE: For R/C see clause 7.2.5.3.8. For FMID, PMID see clause 11.7. For coding of bits $b_{n_{48}}$ to $b_{n_{59}}$ see clause 7.2.5.3.8. These messages are used when modifying a connection (typically as a result of a page with "unknown" service type).

Figure 7.70

Table 7.48a: Void

Table 7.48b

A field modulation type		Meaning
$b_{n_{60}}$	$b_{n_{61}}$	
1	1	2-level modulation
1	0	4-level modulation
0	1	8-level modulation
0	0	reserved

Table 7.48c

(B+Z) fields modulation type		Meaning
bn ₆₂	bn ₆₃	
1	1	2-level modulation
1	0	4-level modulation
0	1	8-level modulation
0	0	bits bn ₄₀ to bn ₄₇ are used to indicate the adaptive code rate and the extended modulation scheme (see note)

NOTE: Extended modulation and adaptive code rates are defined in annex I.

Table 7.48d

(B+Z) fields extended modulation type				Meaning
bn ₄₀	bn ₄₁	bn ₄₂	bn ₄₃	
0	0	0	0	reserved
0	0	0	1	16-level modulation
0	1	0	0	reserved
0	1	0	1	64-level modulation
all other values				reserved

Table 7.48e

Adaptive code rates for extended modulation				Meaning
bn ₄₄	bn ₄₅	bn ₄₆	bn ₄₇	
0	0	0	0	1,0 (no coding)
0	0	0	1	reserved
0	0	1	0	1/3
0	0	1	1	reserved
0	1	0	0	0,4
0	1	0	1	reserved
0	1	1	0	0,5
0	1	1	1	reserved
1	0	0	0	0,6
1	0	0	1	reserved
1	0	1	0	reserved
1	0	1	1	0,75
1	1	0	0	0,8
1	1	0	1	reserved
1	1	1	0	reserved
1	1	1	1	reserved

7.3.2.6 BANDWIDTH_B_{Req;Cfm}

X	0	0	1	1	0	0	R/ C	FMID	spare 1111 0000 1111	spare 0 0 0	MUp	spare 0 0 0	TUp	spare 0 0 0	MDown	spare 0 0 0	TDown
bn ₀							bn ₇	bn ₈ bn ₁₉	bn ₂₀ bn ₃₁	bn ₃₂ bn ₃₉	bn ₄₀ bn ₄₇	bn ₄₈ bn ₅₅	bn ₅₆ bn ₆₃				

Figure 7.71

For R/C, M_{Up}, T_{Up}, M_{Down} and T_{Down} refer to clause 7.2.5.3.9. For FMID refer to clause 11.7.

7.3.2.7 CHANNEL_LIST

X 0 0 1 1 0 1 0	RPN	1st command and channel description	2nd command and channel description	3rd command and channel description
bn ₀	bn ₈ bn ₁₅	bn ₁₆ bn ₃₁	bn ₃₂ bn ₄₇	bn ₄₈ bn ₆₃

Figure 7.72

"Command and channel description" shall have the same coding as in clause 7.2.5.3.10. All three commands and channel descriptions shall apply to the same RFP, identified by RPN.

7.3.2.8 UNCONFIRMED_DUMMY

X 0 0 1 1 0 1 1	FMID	PMID	ECN	spare 1 1 1 1	up/down/sm/ss	ser type	ser type/max life	slot type	A-field mod. type	(B+Z) fields mod. type
bn ₀	bn ₈ bn ₁₉	bn ₂₀ bn ₃₉	bn ₄₀ bn ₄₃	bn ₄₄ bn ₄₇	bn ₄₈ bn ₄₉	bn ₅₀ bn ₅₂	bn ₅₃ bn ₅₅	bn ₅₆ bn ₅₉	bn ₆₀ bn ₆₁	bn ₆₂ bn ₆₃

Figure 7.73

For FMID, PMID see clause 11.7. For coding of bits b₄₈ to b₆₃ see clause 7.2.5.3.8.

7.3.2.9 UNCONFIRMED_HANDOVER

X 0 0 1 1 1 0 0	FMID	PMID	ECN	LBN	up/down/sm/ss	ser type	ser type/max life	slot type	A-field mod. type	(B+Z) fields mod. type
bn ₀	bn ₈ bn ₁₉	bn ₂₀ bn ₃₉	bn ₄₀ bn ₄₃	bn ₄₄ bn ₄₇	bn ₄₈ bn ₄₉	bn ₅₀ bn ₅₂	bn ₅₃ bn ₅₅	bn ₅₆ bn ₅₉	bn ₆₀ bn ₆₁	bn ₆₂ bn ₆₃

Figure 7.74

For FMID, PMID see clause 11.7. For coding of bits b₄₈ to b₆₃ see clause 7.2.5.3.8.

7.3.2.10 RELEASE

	FMID	PMID	Spare or info 1	LBN	Spare or info 2	reason
X 0 0 1 1 1 1 1						
bn ₀	bn ₈ bn ₁₉	bn ₂₀ bn ₃₉	bn ₄₀ bn ₄₃	bn ₄₄ bn ₄₇	bn ₄₈ bn ₅₅	bn ₅₆ bn ₆₃

Figure 7.75

For FMID, PMID see clause 11.7. For coding of bits b₄₄ to b₄₇ see clause 7.2.5.3.8, for b₅₆ to b₆₃ see table 7.49.

Table 7.49

Reason								Explanation for release
0	0	0	0	0	0	0	0	unknown
0	0	0	0	0	0	0	1	bearer release (reduce capacity)
0	0	0	0	0	0	1	0	connection release
0	0	0	0	0	0	1	1	bearer setup or handover failed
0	0	0	0	0	1	0	0	bearer handover successfully completed
0	0	0	0	0	1	0	1	attempted bearer HO to another cluster
0	0	0	0	0	1	1	0	timeout, loss of signal
0	0	0	0	0	1	1	1	timeout, loss of handshake
0	0	0	0	1	0	0	0	requested unacceptable slot type
0	0	0	0	1	0	0	1	requested unacceptable MAC service
0	0	0	0	1	0	1	0	base station busy
0	0	0	0	1	0	1	1	reverse direction (double simplex)
0	0	0	0	1	1	0	0	duplicate PMID
0	0	0	0	1	1	0	1	unacceptable PMID
0	0	0	0	1	1	1	0	target number exceeded
0	0	0	0	1	1	1	1	stay on listen for fast setup mode
0	0	0	1	0	0	0	0	}
to								}
1	1	1	1	1	1	1	1	}
NOTE: "Bearer handover successfully completed" is only intended for use in double simplex release.								

The reason code "Stay on listen for fast setup mode" is intended for the release of last bearer during a DPRS connection suspension [9]. It can be used by the FT only, either in a FT initiated unacknowledged released or as a FT message in an PT initiated release (crossed release). In this case, the fields info 1 and info 2 carry additional information (see table 7.49a).

Table 7.49a

Reason code bn ₄₈	bn ₅₅	info 1 bn ₄₀ bn ₄₃	info2 bn ₄₈ bn ₄₉	info2 bn ₅₀ bn ₅₅	meaning
"00001111" stay on listen for setup mode		1111	00	11111	Stay on complete listen for fast setup mode (all downlink slots), fast setup scan sequence
		SN (slot number)	00	CN (≠11111)	Stay on selective listen for fast setup mode on slot SN (SEL1 mode), on channel CN (channel 111111 not allowed)
		SN (slot number)	00	11111	Stay on selective listen for fast setup mode on slot SN (SEL1 mode), on fast setup scan sequence
		SN (slot number)	01	11111	Stay on selective listen for fast setup mode on slots SN and SN + 6 (SEL 2 mode) on fast setup scan sequence
		SN (slot number)	10	11111	Stay on selective listen for fast setup mode on slots SN and SN + 2 (SEL 2B mode) on fast setup scan sequence
		1111	10	11111	Stay on selective listen for fast setup mode. Slots and channels are indicated on LISTEN messages (B-field) in this same bearer
any other reason code		0000	00	001111	Spare fields

The fields info 1 and info 2 are only used if the reason code is "stay on listen for fast setup mode". Otherwise they are spare fields filled as indicated in table 7.49a.

7.3.3 Null or I_{PF} segmentation info

This message has two meanings depending on the NCF codes:

- Filling B_n subfields when there is no I data or C_F data or G_F data or other M_{B_n} messages to send (NULL).
- Transporting segmentation info for the I_{PF} data channel (I_{PF} segmentation info).

				NCF	extended NCF	Spare or segmentation info	
X	0	1	0				
bn ₀	bn ₃			bn ₄	bn ₇	bn ₈	bn ₁₅ bn ₁₆ bn ₆₃

Figure 7.76

Table 7.50

NCF				Meaning
0	0	0	0	no C _F or CL _F data in the B-field
0	0	0	1	one B-subfield contains C _F or CL _F data
0	0	1	0	two B-subfields contain C _F or CL _F data
0	0	1	1	three B-subfields contain C _F or CL _F data
0	1	0	0	four B-subfields contain C _F or CL _F data
0	1	0	1	five B-subfields contain C _F or CL _F data
0	1	1	0	six B-subfields contain C _F or CL _F data
0	1	1	1	seven B-subfields contain C _F or CL _F data
1	0	0	0	eight B-subfields contain C _F or CL _F data
1	0	0	1	nine B-subfields contain C _F or CL _F data
1	0	1	0	This is an E+U slot, and the U subfields contain the first part of a DLC PDU (see note 4)
1	0	1	1	This is an E+U slot, and the U subfields contain the first part of a DLC PDU, and the rest of the PDU is empty (filling with padding bits, see notes 1, 2 and 4)
1	1	0	0	This is an E+U slot, any other case, (see notes 3 and 4)
1	1	0	1	}
to				} reserved
1	1	1	0	}
1	1	1	1	the multiplex for 4-level, 8-level, 16-level and 64-level is indicated in bits bn ₈ to bn ₁₅
NOTE 1: If the transmitter uses this code, it should not transmit more segments of the PDU.				
NOTE 2: Padding bits are defined by the DLC layer (see EN 300 175-4 [4]).				
NOTE 3: The bits bn ₁₆ to bn ₆₃ contain additional information for the segmentation control.				
NOTE 4: This message, when NCF codes are "1010", "1011" or "1100" is considered segmentation info for E/U-MUX priority scheme (clause 6.2.2.4).				

7.3.3.1 Spare or I_{PF} segmentation info

For NCF = "1100" this field carries the following information.

Table 7.50a

Octet	bits	meaning
1	bn ₁₆ - bn ₂₃	Send sequence number of the first PDU transported in this slot (see note 1)
2	bn ₂₄	9 th bit of the send sequence number (see note 2)
2	bn ₂₅	=1 Indicates this is the last segment of the PDU
2	bn ₂₆	=1 Indicates that the rest of the PDU shall be filling with padding (see note 3)
2	bn ₂₇	=1 Indicates that there is a second PDU segment in this slot
2	bn ₂₈ - bn ₃₁	Sequence number of the PDU segment (see note 4)
3	bn ₃₂ - bn ₃₉	Size (in blocks of 64 bits) of the PDU segment (see note 5)
4	bn ₄₀ - bn ₄₇	only used if bn ₂₇ =1. Same meaning as octet 1, but for the second PDU (see notes 6 and 7)
5	bn ₄₈ - bn ₅₅	only used if bn ₂₇ =1. Same meaning as octet 2, but for the second PDU (see notes 6 and 7)
6	bn ₅₆ - bn ₆₃	only used if bn ₂₇ =1. Same meaning as octet 3, but for the second PDU (see notes 6 and 7)
NOTE 1: Copy of the first octet of the PDU.		
NOTE 2: Applicable only to some LU frames (LU10). If not used, it shall be set to "0".		
NOTE 3: In this case, the rest of the PDU shall not be transmitted.		
NOTE 4: Sequence number of the segment (1,2,3,4 ...).		
NOTE 5: For first PDU segment, the size is the number of 64 bit blocks from the beginning of the U plane section to the end of the PDU segment. It shall be < number of subfields available.		
NOTE 6: If used, the second PDU starts immediately after the first one (position indicated by octet 3).		
NOTE 7: If octets 4-6 are not used, they shall be filled with "0000 1111".		

For any other value of NCF, this field shall be padded with the pattern "0000 1111 0000 1111 0000 1111".

7.3.3.2 Extended NCF bits

This field is only used in high level modulation. For NCF = "1111" this field carries the following information.

Table 7.50b

Extended NCF								Meaning
0	0	0	0	0	0	0	0	0 C _F or CL _F data in the B-field
0	0	0	0	0	0	0	1	1 C _F or CL _F data in the B-field
0	0	0	0	0	0	1	0	2 C _F or CL _F data in the B-field
0	0	0	0	0	0	1	1	3 C _F or CL _F data in the B-field
0	0	0	0	0	1	0	0	4 C _F or CL _F data in the B-field
0	0	0	0	0	1	0	1	5 C _F or CL _F data in the B-field
0	0	0	0	0	1	1	0	6 C _F or CL _F data in the B-field
0	0	0	0	0	1	1	1	7 C _F or CL _F data in the B-field
0	0	0	0	1	0	0	0	8 C _F or CL _F data in the B-field
0	0	0	0	1	0	0	1	9 C _F or CL _F data in the B-field
to								
0	0	1	1	1	0	1	1	59 C _F or CL _F data in the B-field
0	0	1	1	1	1	0	0	60 C _F or CL _F data in the B-field
0	0	1	1	1	1	0	1	}
to								}
1	1	1	1	1	1	1	1	} reserved

7.3.4 Quality control

7.3.4.1 General format

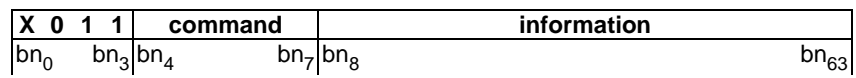

Figure 7.77

Table 7.51

Command				Meaning
0	0	0	0	} Bearer and Connection Control
to				
1	0	0	0	} reserved
1	0	0	1	
to				
1	1	0	1	
1	1	1	0	Reset
1	1	1	1	Bearer quality in an asymmetric connection

7.3.4.2 Bearer and connection control

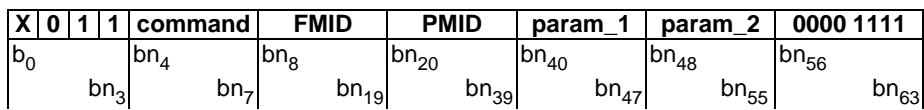

Figure 7.78

Table 7.52

Command				Param_1	Param_2	Meaning
0	0	0	0	LBN LBN	LBN LBN	antenna switch for the bearer(s) identified by LBN request: PT --> FT reject: FT --> PT
0	0	0	1	RPN	0000 1111	antenna switch for all bearers of this connection to the RFP identified by its RPN request: PT --> FT reject: FT --> PT
0	0	1	0	0000 LBN	LBN LBN (see note 8)	bearer handover/bearer replacement of the bearer(s) identified by LBN request: FT --> PT reject: PT --> FT
0	0	1	0	1111 LBN	LBN LBN (see note 8)	bearer handover/bearer replacement of the bearer(s) identified by LBN request: PT --> FT reject: FT --> PT
0	0	1	1	0000 1111	0000 1111	connection handover request: FT --> PT reject: PT --> FT
0	1	0	0	0000 LBN	frequency error	frequency control for the bearer identified by LBN request: FT --> PT reject: PT --> FT
0	1	0	1	RPN	frequency error	frequency control for all bearers of this connection to the RFP identified by its RPN request: FT --> PT reject: PT --> FT
0	1	1	0	RPN	advance timing increment decrement	Advance timing for all the bearers of this connection to the RFP identified by its RPN request: FT --> PT reject: PT --> FT
0	1	1	1	RPN	0000 1111	PT --> FT: PT informs that it is transmitting prolonged preamble in all the frames
1	0	0	0	0000 SN	0000 CN	frequency replacement to carrier CN on slot pair SN request PT -> FT confirm FT -> PT
1	0	0	0	0001 SN	0000 CN	frequency replacement to carrier CN on slot pair SN grant PT -> FT
1	0	0	1			}
to						} Reserved
1	1	0	1			}
NOTE 1: The function of these commands depends on the transmission direction. The commands are either requests or reject. A reject should only be used if the requested action is not supported.						
NOTE 2: For the bearer handover request, the RPN is an optional parameter. If set to all "0" the FP does not propose a particular RFP for handover.						
NOTE 3: A PP may or may not accept the RFP's proposal of the new RPN.						
NOTE 4: The frequency error in kHz is encoded in 2's complement form, to give a range of +127 kHz to -128 kHz. The least significant bit of the error is placed in bit position $b_{n_{55}}$.						
NOTE 5: The advance timing changes are encoded in 2's complement form (+127 bits to -128 bits). The LSB of the advance timing is placed in position a_{31} . Changes with less than 2 bits should not be requested.						
NOTE 6: The bearer handover request command in the PT to FT direction is used in the double simplex bearer handover procedure.						
NOTE 7: Duplicate the last used LBN to all not used LBN parameter fields to ensure detection capability for the receiver. Values 0000 and 1111 can be ignored.						
NOTE 8: The param_2 field in previous versions was RPN, now LBN LBN. This can result in ambiguity! This coding has been changed for B-field messages only, because it was standardized in EN 301 649 [9] (DPRS).						

7.3.4.3 RESET

This message shall only be used in the MAC I_p _error_correction service.

X 0 1 1 1 1 1 0	FMID	PMID	ctrl	LBN	spare 0000 1111	spare 0000 1111
bn_0	bn_8	bn_{20}	bn_{40}	bn_{44}	bn_{48}	bn_{56}
	bn_7	bn_{19}	bn_{39}	bn_{43}	bn_{47}	bn_{55}
						bn_{63}

Figure 7.79

For FMID, PMID see clause 11.7. For coding of bits b_{40} to b_{43} , see table 7.53; for b_{44} to b_{47} , see clause 7.2.5.3.8.

Table 7.53

Ctrl				Meaning
0	0	X	X	request
0	1	X	X	confirm
0	X	0	0	reserved
0	X	0	1	first TDMA half frame
0	X	1	0	second TDMA half frame
0	X	1	1	both TDMA half frames
1	X	X	X	reserved

7.3.4.4 Bearer quality in an asymmetric connection

X 0 1 1 1 1 1 1	Acknowledgements for channels in the first half of the frame	Acknowledgements for channels in the second half of the frame
bn_0	bn_8	bn_{36}
	bn_7	bn_{35}
		bn_{63}

Figure 7.80

Acknowledgements for physical channels in the first half of the TDMA frame.

LBN1		LBN2		LBN3		LBN4		LBN5		...	LBN14	
Q1/ BCK	Q2	Q1/ BCK	Q2	Q1/ BCK	Q2	Q1/ BCK	Q2	Q1/ BCK	Q2		Q1/ BCK	Q2
bn_8	bn_9	bn_{10}										bn_{35}

Figure 7.81

Acknowledgements for physical channels in the second half of the TDMA frame.

LBN1		LBN2		LBN3		LBN4		LBN5		...	LBN14	
Q1/ BCK	Q2	Q1/ BCK	Q2	Q1/ BCK	Q2	Q1/ BCK	Q2	Q1/ BCK	Q2		Q1/ BCK	Q2
bn_{36}												bn_{63}

Figure 7.82

In pairs two bits are related to one simplex half of a double simplex bearer identified by the LBN. Depending on the MAC layer service the meaning of these bits is different.

- For I_N and I_p _error_detection services the two bits have the function of the Q1 and Q2 bit. The setting of the Q1 and Q2 bit are described in the procedures of clause 10.8.1.3.
- For the I_p _error_correction service the two bits have the function of the BCK and Q2 bit. The coding of these bits is described in clause 10.8.2.4.

7.3.5 Extended system information

7.3.5.1 General format

X 1 0 0	command	information
bn ₀ bn ₃	bn ₄ bn ₇	bn ₈ bn ₆₃

Figure 7.83

Table 7.54

Command				Meaning
0	0	0	0	TARI messages
0	0	0	1	"no-emission" mode sync information or ULE Dummy Bearer subfield 2
0	0	1	0	ULE Dummy Bearer subfield 3
0	0	1	1	}
to				}
reserved				
1	0	0	1	}
1	0	1	0	ULE Dummy Bearer subfield 0
1	0	1	1	ULE Dummy Bearer subfield 1
1	1	1	0	}
to				}
reserved				
1	1	1	1	}

NOTE: code '0001'B is reused in NEMO and ULE formats. They can be distinguished by the different position in the B subfields.

7.3.5.2 TARI messages

The management entity in the transmitting radio endpoint supplies the MAC layer with a 36 bit SDU via the ME SAP. At the receiving endpoint the MAC layer passes the 36 bit SDU out through the ME SAP to the management entity.

X 1 0 0 0 0 0 0	TARI field	spare 1111	spare 0000 1111	spare 0000 1111
bn ₀ bn ₇	bn ₈ bn ₄₃	bn ₄₄	bn ₄₄ bn ₆₃	bn ₆₃

Figure 7.84: TARI messages

For the coding of the TARI field refer to EN 300 175-6 [6].

7.3.5.3 "no-emission" mode sync information or ULE Dummy Bearer subfield 2

This clause defines the details of the data that is transmitted in the B-field when the header and command indicates "no-emission" mode sync information or ULE Dummy Bearer subfield 2 ("X1000001"). The meaning of this information is altered depending upon the type of dummy bearer to which the B-field is attached. There are two possible mappings allocated for this code:

- subfield used for B-field attached to standard dummy bearer – "no-emission" mode sync information
- subfield used for B-field attached to ULE dummy bearer – ULE Dummy Bearer subfield 2.

7.3.5.3.1 "no-emission" mode sync information for dummy bearer

This clause defines the details of the "no-emission" mode sync information that is transmitted in the B-field of the dummy bearer when the header and command indicates "no-emission" mode sync information ("X1000001").

X 1 0 0 0 0 0 1	Lock-Slot	Spare	PSCN	FCNT Frame counter	MFN Multiframe number	Paging info	
						Info type	MAC info
bn ₀	bn ₇	bn ₈ bn ₁₁	bn ₁₂ bn ₁₃	bn ₁₄ bn ₁₉	bn ₂₀ bn ₂₃	bn ₂₄ bn ₄₇	bn ₄₈ bn ₅₁ bn ₅₂ bn ₆₃

Figure 7.85: "no-emission" mode sync information

Description of the fields:

Lock-Slot:

Slot number of the standard-dummy bearer (coding: see clause 7.2.3.2.3).

PSCN:

Primary receiver scan carrier number (coding: see clause 7.2.3.2.12).

FCNT (Frame counter):

current frame count (0...15).

MFN (Multiframe number):

(coding: see clause 7.2.3.7.2).

Paging info:

multiplexed PT MAC layer information (coding: see clause 7.2.4.3).

7.3.5.3.2 ULE Dummy Bearer subfield 2

This clause defines the details of the ULE Dummy Bearer subfield 2 that is transmitted in the B-field of the ULE dummy bearer when the header and command indicates ULE Dummy Bearer subfield 2 ("X1000001"). For phase 1 of the ULE this will always be the subfield defined by bits bn₀ = 160 to bn₆₃ = 223.

X 1 0 0 0 0 0 1	40 bits of Q_C channel data	16 bits of M_U channel data
bn ₀	bn ₇ bn ₈	bn ₄₇ bn ₄₈ bn ₆₃

Figure 7.86: ULE Dummy Bearer subfield 2

For details of the Q_C channel and M_U channel contents see clause 9.5.

7.3.5.4 ULE Dummy Bearer subfield 3

This clause defines the details of the ULE Dummy Bearer subfield 3 that is transmitted in the B-field of the ULE dummy bearer when the header and command indicates ULE Dummy Bearer subfield 3 ("X1000010").

X 1 0 0 0 0 1 0	56 bits of P_U channel data
bn ₀	bn ₇ bn ₈ bn ₆₃

Figure 7.87: ULE Dummy Bearer subfield 3

For details of the P_U channel contents see clause 9.5.

7.3.5.5 ULE Dummy Bearer subfield 0

This clause defines the details of the ULE Dummy Bearer subfield 0 that is transmitted in the B-field of the ULE dummy bearer when the header and command indicates ULE Dummy Bearer subfield 0 ("X1001010").

X 1 0 0 1 0 1 0	28 bits of Q_C channel data	28 bits of N_S channel data
bn ₀ bn ₇	bn ₈ bn ₃₅	bn ₃₆ bn ₆₃

Figure 7.88: ULE Dummy Bearer subfield 0

For details of the Q_C channel and N_S channel contents see clause 9.5.

7.3.5.6 ULE Dummy Bearer subfield 1

This clause defines the details of the ULE Dummy Bearer subfield 1 that is transmitted in the B-field of the ULE dummy bearer when the header and command indicates ULE Dummy Bearer subfield 1 ("X1001011").

X 1 0 0 1 0 1 1	12 bits of N_S channel data	44 bits of P_U channel data
bn ₀ bn ₇	bn ₈ bn ₁₉	bn ₂₀ bn ₆₃

Figure 7.89: ULE Dummy Bearer subfield 0

For details of the N_S channel and P_U channel contents see clause 9.5.

7.3.6 G_F channel data packet

X 1 0 1	NCF	56 bit G_F channel SDU
bn ₀ bn ₃	bn ₄ bn ₇	bn ₈ bn ₆₃

Figure 7.90

Table 7.55

NCF				Meaning
0	0	0	0	no C _F data in the B-field
0	0	0	1	one B-subfield contains C _F data
0	0	1	0	two B-subfields contain C _F data
0	0	1	1	three B-subfields contain C _F data
0	1	0	0	four B-subfields contain C _F data
0	1	0	1	five B-subfields contain C _F data
0	1	1	0	six B-subfields contain C _F data
0	1	1	1	seven B-subfields contain C _F data
1	0	0	0	eight B-subfields contain C _F data
1	0	0	1	nine B-subfields contain C _F data
1	0	1	0	This is an E+U slot, and the U part contains the first part of a DLC PDU
1	0	1	1	This is an E+U slot, and the U part contains the first part of a DLC PDU, and the rest of the PDU is empty (filling with padding bits, see notes 2 and 3)
1	1	0	0	0 outstanding subfields, see note 1
1	1	0	1	1 outstanding subfield, see note 1
1	1	1	0	2 outstanding subfields, see note 1
1	1	1	1	> 2 outstanding subfields, see note 1
NOTE 1: If there are more than 9 subfields in total, then the outstanding subfields are indicated.				
NOTE 2: If the transmitter uses this code, it shall not transmit more segments of the PDU.				
NOTE 3: Padding bits are defined by the DLC layer (see EN 300 175-4 [4]).				
NOTE 4: NCF codes "1010" and "1011" and "1100" are considered segmentation info for E/U-MUX priority scheme (see clause 6.2.2.4).				

7.3.7 Escape

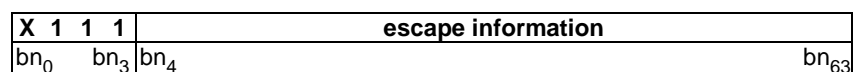

Figure 7.91

Any DECT equipment may transmit an escape message.

The content of the escape information field (bn₄ to bn₆₃) is not specified. This message shall not be used to perform a function that is specified in another part of the DECT CI standard.

8 Medium access layer primitives

The contents of clause 8 are for information only. This clause is aimed to assist in the description of layer to layer procedures.

These primitives are abstract and their concrete representations may vary from implementation to implementation. Therefore, they shall not be considered to be a testable entity.

Four types of primitives exist, Request (req), Indicate (ind), Response (res) and Confirm (cfm). A "cfm" primitive only occurs as confirmation of an action initiated by a "req" primitive. A "res" primitive can only follow an "ind" primitive. The direction of the primitives is shown in figure 8.1.

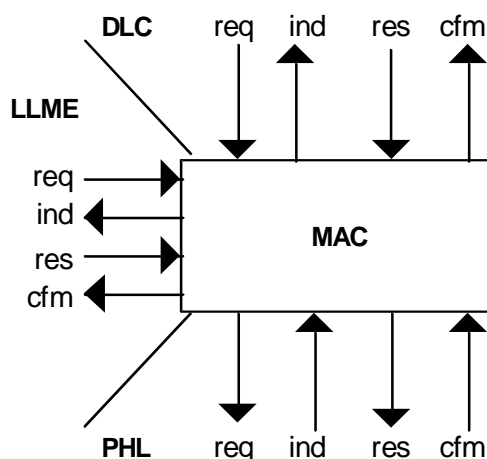

Figure 8.1: MAC layer primitives

8.1 Connection oriented service primitives

Connections are identified by the MAC Connection Endpoint Identifier, MCEI.

8.1.1 Connection setup: MAC_CON {req;ind;cfm}

Parameter list:

Table 8.1

Parameter	Req	Ind	Cfm
MCEI	X	X	X
FMID (see note 1)	X	X	-
PMID	X	X	-
connection handover	X	X	-
old MCEI (see note 2)	X	-	-
C _F required	X	X	-

Parameter	Req	Ind	Cfm
slot type	X	X	-
service type	X	X	-
max lifetime (see note 3)	O	X	-
up/down/sm/ss (see note 4)	O	X	-
connection type	-	X	X
ECN (see note 5)	-	X	X
Broadband data link ECN (see note 6)	X	-	-
X = parameter exists. O = parameter optional. - = parameter does not exist in this primitive.			
NOTE 1: FMID is only needed for fixed part initiated "fast setup".			
NOTE 2: The "old MCEI" parameter is only needed if "connection handover" = "yes" and the previous "connection type" = "basic".			
NOTE 3: The "maximum lifetime" parameter only applies to the I _P _error_correction service. The setting of this parameter in the MAC_CON-req primitive is optional. Default value (i.e. assumed when not set) is: maximum lifetime = unlimited.			
NOTE 4: The setting of this parameter in the MAC_CON-req primitive is optional. Default value is "ss", the symmetric single bearer connection.			
NOTE 5: The "ECN" parameter is only used if "connection type" = "advanced".			
NOTE 6: The "Broadband data link ECN" is used only with connections that belong to a Broadband data link and only for the setup of the second and third connections - i.e. not used for the setup of the first connection. The value of the "Broadband data link ECN" parameter shall be the ECN of the first established connection. The parameter is used to provide MAC with a means to identify associated in one Broadband data link connections.			

Parameter values:

MCEI	= local matter;
connection handover	= { yes, no };
old MCEI	= local matter, or null;
C _F required	= { yes, no };
service type	= { I _N _minimum_delay, I _N _normal_delay, I _P _error_detection, I _P _error_correction, U-plane unknown, C channel only, I _{PQ} _error_detect, I _{PQ} _error_correct };
slot type	= { double, full, half with j=80, long with j=640 or j=672 };
maximum lifetime	= { unlimited, 1, 2, ..., 7 };
up/down/sm/ss: up	= asymmetric uplink connection;
down	= asymmetric downlink connection;
sm	= symmetric multibearer connection;
ss	= symmetric single bearer connection;
connection type	= { basic, advanced };
ECN	= {0, 1, ... 15};
Broadband data link ECN	= {0, 1, ... 15}.

8.1.2 Connection modification: MAC_MOD {req;ind;cfm}

Parameter list:

Table 8.2

Parameter	Req	Ind	Cfm
MCEI	X	X	X
ECN	X	X	X
slot type	X	X	-
switching	O	O	-
service type	X	X	-
max lifetime	O	O	-
target number of uplink simplex bearers	O	-	-
target number of downlink simplex bearers	O	-	-
minimum acceptable uplink simplex bearers	O	-	-
minimum acceptable downlink simplex bearers	O	-	-
result	-	X	X
modulation type	O	O	O
adaptive code rate	O	O	X
X = parameter exists. O = parameter optional. - = parameter does not exist in this primitive.			

Parameter values are the same as MAC_CON except:

MCEI = local matter;

ECN = {0, 1, ... 15};

switching = {full to double, double to full, full to full, full to half, half to full, full to long, long to full, long to double, double to long, basic to advanced, none};

slot type = { double, full, half with j=80, long with j=640 or j=672 };

service type = { I_N_minimum_delay, I_N_normal_delay, I_P_error_detection, I_P_error_correction, C channel only, I_{PQ}_error_detect, I_{PQ}_error_correct, I_P_encoded_protected };

maximum lifetime = { unlimited, 1, 2, ..., 7 };

target number of uplink simplex bearers = {1,2, ... 29};

target number of downlink simplex bearers = {1,2, ... 29};

minimum acceptable uplink simplex bearers = {1,2, ... 29};

minimum acceptable downlink simplex bearers = {1,2, ... 29}.

result = {accept, reject}.

Modulation type = {2-level mod. in (B+Z) fields; 2-level mod. in the A-field; 4-level-mod. in (B+Z)-fields; 4-level mod. in the A-field; 8-level mod. in (B+Z) fields; 8-level mod. in the A-field; 16-level mod. in (B+Z) fields, 64-level mod. in (B+Z) fields}

adaptive code rate = {0,1...1,0}.

NOTE 1: Target number ≥ minimum acceptable.

NOTE 2: If "slot type" = "half" then target number = minimum acceptable = 1.

"Slot type" shall only be used to adjust j.

NOTE 3: If the "modulation type" parameter is not present, the correct modulation scheme is confirmed.

8.1.3 CO data transmit ready: MAC_CO_DTR {ind}

Table 8.3

Parameter	Ind
MCEI	X
data channel type	X
number of segments	X
number of duplex bearers	X
X = parameter exists.	

Data channel type = { G_F , C_S , C_F , I_N , I_P }.

Number of segments = { 0, 1, ... 30 }.

Number of duplex bearers = integer; this value is only set for data channel type C_F .

8.1.4 CO data transfer: MAC_CO_DATA {req;ind}

Parameter list:

Table 8.4

Parameter	Req	Ind
MCEI	X	X
transmit data channel type	X	-
receive data channel type	-	X
number of segments	X	X
number of bearers for control	X	-
SDU	X	X
CRC Results	-	O
X = parameter exists.		
O = parameter optional.		
- = parameter does not exist in this primitive.		

Parameter values:

transmit data channel type = { G_F , C_S , C_F , I_N , I_P , null };

receive data channel type = { G_F , C_S , C_F , I_N , I_P , unknown };

number of segments = { 0, 1, ... 29 };

no of bearers for control = integer; this parameter is only set if transmit channel type is C_F ;

CRC results = local matter.

NOTE: Except I_N , all data is provided with MAC layer 16 or 32 bit CRCs. Indicating the CRC results may be needed in error detect services.

8.1.5 Restart DLC: MAC_RES_DLC {ind}

Parameter list:

Table 8.5

Parameter	Ind
MCEI	X
X = parameter exists.	

8.1.6 Connection release: MAC_DIS {req;ind}

Parameter list:

Table 8.6

Parameter	Req	Ind
MCEI	X	X
reason	-	O
X	= parameter exists.	
O	= parameter optional.	
-	= parameter does not exist in this primitive.	

Reason = { normal, abnormal }.

NOTE: Disconnect with the aim of reconnecting should be performed by sending appropriate higher layer messages before issuing this primitive.

8.1.7 MAC bandwidth: MAC_BW {ind;res}

Parameter list:

Table 8.7

Parameter	Ind	Res
MCEI	X	X
target number of uplink simplex bearers	X	-
target number of downlink simplex bearers	X	-
minimum acceptable uplink simplex bearers	X	-
minimum acceptable downlink simplex bearers	X	-
X	= parameter exists.	
-	= parameter does not exist in this primitive.	

Parameter values:

MCEI = local matter;

target number of uplink simplex bearers = {1, 2, ..., 29};

target number of downlink simplex bearers = {1, 2, ..., 29};

minimum acceptable uplink simplex bearers = {1, 2, ..., 29};

minimum acceptable downlink simplex bearers = {1, 2, ..., 29}.

8.1.8 Encryption

8.1.8.1 Load encryption key: MAC_ENC_KEY {req}

Parameter list:

Table 8.8

Parameter	Req
MCEI	X
SDU, containing encryption key	X
Code of the algorithm to be used in the KSG	O
X	= parameter exists.
O	= to be used only if several algorithms are supported.

8.1.8.2 Enable/disable encryption: MAC_ENC_EKS {req;ind;cfm}

Parameter list:

Table 8.9

Parameter	Req	Ind	Cfm
MCEI	X	X	X
"go crypted/go clear" flag	X	X	X
X = parameter exists.			

8.1.9 C-plane switching procedure

8.1.9.1 C-plane switching procedure: MAC_CS_CF {req, cfm, ind, res}

Parameter list:

Table 8.10

Parameter	Req	Ind	Res	Cfm
MCEI	X	X	X	X
LCN old	X	X	X	X
LCN new	X	X	X	X
switching type	X	X	X	X
result	X	X	X	X
X = parameter exists.				
- = parameter optional.				

Parameter values:

MCEI = local matter;

LCN old = {0, 1, ...,7};

LCN new = {0, 1, ...,7};

switching type: {C_S to C_F, C_F to C_S, C_S to C_S};

result: accept/reject.

8.1.9.2 C-plane switching procedure: MAC_CS_CF_END {ind}

Parameter list:

Table 8.11

Parameter	Ind
MCEI	X
LCN old	X
LCN new	X
switching type	X
result	X
X = parameter exists.	
- = parameter optional.	

Parameter values:

MCEI = local matter;

LCN old = {0, 1, ...,7};

LCN new = {0, 1, ...,7};

switching type: { C_S to C_F, C_F to C_S, C_S to C_S};

result: accept/reject.

8.2 Connectionless and broadcast service primitives

8.2.1 Paging: MAC_PAGE {req;ind}

Parameter list:

Table 8.12

Parameter	Req	Ind
cluster ID	X	X
page type	X	-
length of page field	X	-
long flag	X	X
SDU	X	X
CRC results	-	O
X = parameter exists. O = parameter optional. - = parameter does not exist in this primitive.		

Parameter values:

cluster ID = { all clusters/an integer };

page type = { fast, normal };

length of page field = {0, 20, 36, 72, 108, 144, 180, 216};

long flag = { long, other }; this parameter is only needed for page fields of length 36;

CRC results = local matter.

8.2.2 Downlink connectionless: MAC_DOWN_CON {req;ind}

Table 8.13

Parameter	Req	Ind
logical channel	X	X
number of segments	X	X
ARI	-	X
data contains errors	-	X
SDU	X	X
X = parameter exists. - = parameter does not exist in this primitive.		

logical channel = { CL_F, CL_S, SI_N, SI_P }.

number of segments = { 1 ... 10 }.

NOTE: Number of segments is only needed for CL_F data.

8.2.3 Uplink connectionless: MAC_UP_CON {req;ind;cfm}

Table 8.14

Parameter	Req	Ind	Cfm
SDU length	X	X	-
SDU	O	O	-
PMID	-	X	-
data contains errors	-	X	-
status			X
X = parameter exists. O = parameter optional. - = parameter does not exist in this primitive.			

SDU length = { 0, 40, $n \times 64$ }; $n = \{ 1, 2, \dots 20 \}$.

status = { no C/L uplink service, CL_F not supported, data transmitted }.

8.2.4 "no-emission" mode

Primitives for "no-emission" mode are for further study.

8.3 Management primitives

Parameter values shall not be defined for the management primitives in the present document to allow the possibility of alternative implementations.

8.3.1 Connection control

8.3.1.1 Connection setup: MAC_ME_CON {ind}

Parameters:

- basic/advanced connection;
- ECN (if advanced connection and connection handover);
- new connection/bearer handover/connection handover;
- old MCEI (if connection handover);
- Broadband data link ECN (for second and third connections of a Broadband data link).

8.3.1.2 Connection setup allowed: MAC_ME_CON_ALL {req}

Parameters:

- forbid/allow flag;
- forbid reason (i.e. asked for basic, can retry with advanced);
- ECN;
- new MBC required;
- MCEI.

8.3.1.3 Bearer release: MAC_ME_REL {req}

This primitive is used by the LLME to release a bearer due to not finding an MBC on handover.

8.3.1.4 MBC release report: MAC_ME_REL_REP {ind}

Parameter:

- ECN.

8.3.2 System information and identities

8.3.2.1 FP information preloading: MAC_ME_RFP_PRELOAD {req}

Parameters:

- PARI;
- RPN;
- SARI;
- fixed part capabilities;
- multiframe number.

8.3.2.2 PT information preloading: MAC_ME_PT_PRELOAD {req}

Parameters:

- assigned individual TPUI;
- assigned/default flag.

8.3.2.3 System information output: MAC_ME_INFO {ind;res}

Parameters:

- PARI;
- RPN;
- SARI;
- fixed part capabilities;
- multiframe number.

8.3.2.4 Extended system info: MAC_ME_EXT.{req;ind;res;cfm}

Parameters:

- FMID;
- PMID;
- SDU.

8.3.3 Channel map: MAC_ME_CHANMAP {ind;res}

Parameters:

- strongest channels;
- Quietest/free channels.

8.3.4 Status reports: MAC_ME_STATUS {req;ind;res;cfm}

Parameters:

- call status;
- slot drift/slot theft (X-field) report;
- CRC report (retransmission report);
- timer status;
- handover required;
- diversity switch required.

8.3.5 Error reports: MAC_ME_ERROR {ind;res}

Parameters:

- service overload;
- call failure.

8.4 Flow control

8.4.1 MA SAP flow control

Transmitter: the BMC of an FT may accept MAC_PAGE-req primitives. According to the paging type (fast or normal, see clause 9.1.3.1), the SDU length, and the T-Mux algorithm the BMC will distribute the P channel information to all TBCs, CBCs and DBCs of a cluster. If the BMC cannot distribute the SDU contained in the MAC_PAGE-req primitive, that SDU is discarded and nothing is returned to the higher layers.

Receiver: the BMC in a PT may receive paging messages from any bearer. If B_S channel messages were received in one TDMA frame the BMC should send at least one of these messages with a MAC_PAGE-ind primitive to the DLC.

8.4.2 MB SAP flow control

The flow control of SI_N , SI_P , CL_S and CL_F channel data depends on the transmission direction and the connectionless service. Flow control is described separately for downlink and uplink directions in the corresponding procedures in clauses 9.1.2 and 9.2 respectively.

8.4.3 MC SAP flow control

The MBC shall request the DLC for all data to be transmitted from the C_S , C_F , G_F , I_N and I_P channel. With the MAC_CO_DTR-ind primitive the MBC may request for segments of several channels or selectively for segments of only one channel. The DLC responds by issuing one or several MAC_CO_DATA-req primitives to the MAC. A MAC_CO_DATA primitive shall carry data segments from only one logical (sub)channel. Data is delivered from the MAC to the DLC with the MAC_CO_DATA-ind primitive.

The following primitive flow shall be provided on the transmitting side:

- a) **C_S and C_F channels:** before an ARQ window starts (see clause 10.8.1) the MAC shall request with MAC_CO_DTR-ind primitives for the maximum number of allowed higher layer control segments (C_S and C_F channel data). By requesting C_F segments the MAC indicates the number of established duplex bearers. The DLC shall respond with MAC_CO_DATA-req primitives. These primitives shall contain at most the indicated number of C_S and C_F segments, and for data type C_F, the number of duplex bearers allowed to carry higher layer control.

NOTE 1: The number of allowed C_S or C_F segments indicated with the MAC_CO_DTR-ind primitive may be zero, e.g. when retransmissions are needed.

If no C_F channel is provided the number of acceptable C_F segments in the MAC_CO_DTR-ind primitive and the number of allowed duplex bearers for higher layer control in the MAC_CO_DATA-req primitive shall always be zero.

The C_F data shall always be transmitted on the allowed number of duplex bearers indicated with the MAC_CO_DATA-req primitive. This rule is also applied for retransmissions of C_F data. The MAC shall only retransmit the C_F data on the number of bearers specified by the DLC, a value "0" disables all retransmissions.

A MAC_CO_DTR-ind primitive may allow the DLC to issue one or more C_F segments. The DLC may respond with a MAC_CO_DATA-req primitive for C_F data that reserves some bearers for higher layer control but the primitive itself does not contain a SDU (i.e. number of C_F segments = 0). The number of reserved bearers shall not be used for I channel data. If no or not sufficient G_F channel data is available (see item d)) the MAC shall fill the remaining segments (see item e)).

- b) **I_N_normal_delay (I_{NB}):** before a TDMA half frame starts the MAC shall request with a MAC_CO_DTR-ind primitive for all new I channel data segments which can be transmitted in this TDMA half frame. The DLC shall reply with a MAC_CO_DATA-req primitive. This primitive shall contain the requested number of I channel segments for the I_N_normal_delay service. For I_P services the number of delivered I_P segments shall not exceed the number indicated in the MAC_CO_DTR-ind primitive. If a TDMA half frame is the beginning half frame of an ARQ window, the I channel request shall follow the C channel request.

If two bearers with the same LBN are maintained during bearer handover, I channel data shall be duplicated on both bearers, the new and the old bearer.

- c) **I_N_minimum_delay (I_{NA}):** just before the transmission of a bearer carrying I_N data in an I_N_minimum_delay service, starts the MAC request with a MAC_CO_DTR-ind primitive this segment. The DLC shall respond with a MAC_CO_DATA-req primitive and deliver an I_N segment.

If two bearers with the same LBN are maintained during bearer handover, I channel data may be different on both bearers. The MAC shall ask for data for the two bearers using two independent primitives. See annex F for information regarding seamless handover operation.

- d) **I_P_error_detect (I_{PQ} or I_{PM}):** just before the transmission of a bearer carrying I_P data in an I_P_error_detect service, the MAC shall request from the DLC a new I_P segment with a MAC_CO_DTR-ind primitive. The DLC shall respond with a MAC_CO_DATA-req primitive delivering a DLC PDU. The MAC shall add CRCs and transmit the DLC PDU as an I_P packet in the bearer.

If two bearers with the same LBN are maintained during bearer handover, I channel data may be the same or different on both bearers (Tx implementation decision). If different, the MAC shall ask for data for the two bearers using two independent primitives. See annex F for information regarding seamless handover operation.

- e) **I_P_error_correct (I_{PQR} or I_{PMR}):** just before the transmission of a bearer carrying new I_P data in an I_P_error_correct service, the MAC shall request from the DLC a new I_P segment with a MAC_CO_DTR-ind primitive. The DLC shall respond with a MAC_CO_DATA-req primitive delivering a DLC PDU. The MAC shall add CRCs and transmit the DLC PDU as a new I_P_error_correct segment on the bearer.

If two bearers with the same LBN are maintained during bearer handover, I channel data on both bearers shall be duplicated as described in clause 10.8.2.6.2. See annex F for information regarding seamless handover operation.

- f) **I_P_encoded_protected (I_{PX}):** the operation of the I_P_encoded_protected service is as the I_P_error_detect, but adding the coding protection (according to the r rate) instead of the CRCs.
- g) **I_{PF}_service:** if I_{PF}_service is supported (see clauses 5.3.1.4 and 10.8.4), just before the transmission of a bearer in E+U multiplexer mode and with capacity to carry I_{PF} segments belonging to a new I_P or I_N packet, the MBC shall request an I_P or I_N packet with a MAC_CO_DTR-ind primitive. The DLC shall respond with a MAC_CO_DATA-req primitive and shall deliver a DLC PDU. The MBC shall segment the received packet into I_{PF} segments, shall add control information, and shall transmit a number of I_{PF} segments in the bearer. The MBC shall be in charge of transmitting the rest of I_{PF} segments of the I_P or I_N packet in next E+U mode bearers without any further request to the DLC.
- h) **G_F channel:** if the G_F channel is used (I_P service) and capacity is available for G_F segments, the MAC request just before the transmission starts with a MAC_CO_DTR-ind primitive and indicates the maximum number of acceptable G_F segments. The DLC may respond with a MAC_CO_DATA-req primitive and deliver at most the indicated number of segments. Capacity can be available on bearers carrying some higher layer control, extended MAC control or on bearers which are not used to carry either C_F or I_P data;
- i) **Filling:** if the DLC delivers insufficient control segments for a particular bearer, the MAC shall fill the remaining segments.

If no control segments are delivered by the DLC, the MAC shall fill all segments.

NOTE 2: I_N mode filling is performed by the DLC.

The following primitive flow shall be provided on the receiving end:

- a) if the A-field CRC fails, the B-field data segments are delivered with a MAC_CO_DATA-ind primitive, and are labelled as "unknown";
- b) correctly received new C_S and C_F data segments shall be delivered with a MAC_CO_DATA-ind primitive to the DLC at TDMA half frame boundaries;
- c) correctly received G_F segments are delivered to the DLC immediately with a MAC_CO_DATA-ind primitive;
- d) for the I_P_error_detection (I_{PM} or I_{PQ}), I_P_error_correction (I_{PMR} or I_{PQR}), I_P_encoded_protected (I_{PX}) and I_N_minimum_delay (I_{NA}) services, correctly received I channel segments are delivered to the DLC immediately with a MAC_CO_DATA-ind primitive; B-field segments labelled as "unknown" may be delivered for I_N_minimum_delay services;
- e) for the I_N_normal_delay service (I_{NB}), correctly received I channel segments are issued to the DLC with MAC_CO_DATA-ind primitives at half frame boundaries. Segments labelled as "unknown" may be delivered for I_N_normal_delay services. Sequencing shall be provided. For sequencing the "unknown" segments are treated as I channel segments;
- f) if the I_{PF}_service is supported, when all the I_{PF} segments of an I_P or I_N packet have been correctly received, the complete I_P or I_N packet is immediately delivered to the DLC.

9 Broadcast and connectionless procedures

9.1 Downlink broadcast and connectionless procedures

This clause describes the procedures for the continuous downlink BMC and CMC services.

9.1.1 Downlink broadcast procedure

9.1.1.1 Broadcast information

The broadcast information provides three basic services to any locked PPs:

- 1) access rights identifiers: (N channel and Q channel);
- 2) system information: (Q channel);
- 3) paging information: (P channel).

Access Rights Identifiers (ARIs):

Access right identifiers are broadcast in two channels. The primary access rights identifier is repeated most frequently using the N channel, and shall be provided by all RFPs. The RFP may indicate the existence of secondary access rights identities. Any SARIs are broadcast as part of the Q channel using the SARI message (see clause 7.2.3.6).

NOTE: Tertiary Access Right Identifiers (TARIs) may also exist. These are available on demand (see clause 9.3).

The ARIs determine if a PP can request service from the RFP, according to the rules given in EN 300 175-6 [6].

System information:

System information gives many details about the operation of the fixed part. This is a mixture of general information, plus RFP specific information.

Certain system information messages are essential for PTs to lock to a system. These messages shall be transmitted by all RFPs. The contents and provisions of these messages and the maximum interval between repeats are defined in clause 7.2.3. Transmission of these messages is described in clause 11.1.1. The PT locking procedure is defined in clause 11.3.

Paging information:

Paging information is used to send transient information to locked PPs. The main application of this service is to deliver call setup messages, these messages are used to connect incoming (FP-originated) calls.

There is a fast and a normal paging mode. In normal paging mode the paging message positions within a multiframe are restricted to minimize the duty cycle of idle locked PPs. This enables idling PPs to switch off for the other frames.

However, paging message delays may occur, and the fast paging mode is defined for cases where a higher duty cycle is acceptable and shorter delay is wanted. Fast paging is expected to be primarily used for data terminals.

Paging procedures are defined in clause 9.1.3.

9.1.1.2 Channel selection for downlink broadcast services

As defined in clause 5.7.1 the continuous broadcast service shall always be available at each CSF. This service shall be provided on:

- all traffic bearers with transmissions in the direction FT to PT;
- any connectionless bearer used for a downlink CMC service;
- all dummy bearers.

Channel selection to provide the downlink broadcast service shall only be applied to setup a dummy bearer, and may occur if either:

- 1) in presence of traffic bearers neither a bearer providing a connectionless downlink service nor a dummy bearer exists; or
- 2) the last bearer with transmissions in the direction FT to PT is released, and neither a dummy bearer nor a bearer providing a connectionless downlink service exists; or
- 3) one dummy bearer but no traffic bearer exists and the CSF tries to install a second dummy bearer; or
- 4) the RFP decides to change the physical channel for a dummy bearer; or
- 5) the RFP receives a "change dummy bearer position" message (see clause 7.2.5.6) and the FT's CSF allows a change; or

NOTE: It depends on the system configuration if a CSF allows a dummy bearer change when requested. FTs may ignore a "change dummy bearer position" message.

- 6) a connectionless downlink service has finished.

Except for situation 6) above, the FT shall choose a channel according to clause 11.4.3 with following preferences:

For situation 2): if the last bearer with transmissions in the direction FT to PT was a traffic bearer, this bearer should be converted into a dummy bearer.

For situation 5): the physical channel proposed in the "change dummy bearer position" message should be chosen if allowed (see clause 11.4.3).

If a CSF decides to install dummy bearer(s) when a connectionless service has finished (situation 6)) above, the CSF shall convert the connectionless downlink bearers to dummy bearers.

The following rules for the placement of the dummy-bearers should be applied so that a PP can always find alternative RFPs when it is locked to one RFP and searches for a stronger one:

- general for TDMA-multicell-systems:
 - at least two bearers (dummy or traffic bearers) need to be TX-active so that a PP can always find its surrounding FPs. This is necessary because one of the two dummies can be hidden in the slot which is RX-active at the PP (for staying locked or maintaining a traffic-bearer);
- when using slow-hopping RF-modules in the PP (this means that slots which are directly neighboured to active receive or transmit slots cannot be used):
 - **with two active dummy bearers:**
 - the slotnumber of the first dummy bearer has to be taken into account during channel-selection of the second dummy bearer. Slot N of the second dummy bearer has to have a minimum distance of 3 slots ($N \pm 3$) relative to the slot of the first dummy bearer;
 - **with one active dummy bearer:**
 - when opening a new traffic-bearer slot it has to be checked in the FP, if the FP can still be "seen" by the PP, i.e. a minimum number of 2 active TX-slots at the FP have got a minimum distance of 3 slots. If this is the case, the dummy bearer can be released. If it is not the case, the dummy bearer has to be moved to a suitable slot;
 - **with no active dummy bearer:**
 - when opening a new traffic-bearer slot it has to be checked in the FP, if the FP can still be "seen" by the PP, i.e. a minimum number of 2 active TX-slots at the FP have got a minimum distance of 3 slots. If this is not the case, a dummy bearer has to be activated in a suitable slot.

9.1.1.3 Downlink broadcast procedure description

The downlink broadcast procedure is defined by the T-MUX rule (see clause 6.2.2.1). This rule defines the distribution of the available capacity for Q, N and P channels.

The Q channel information depends on the system configuration. Q channel capacity shall be split for transmission of the different messages according to the rules defined in clause 7.2.3.1.

The P channel capacity shall be used as defined in clause 9.1.3.

9.1.2 Downlink connectionless procedure

9.1.2.1 Channel selection at the RFP

If dummy bearers exist in the CSF, all dummy bearers shall be converted into connectionless bearers.

When no dummy bearer is present or when the RFP decides to change the physical channel to provide the connectionless downlink service, the RFP shall choose a channel according to clause 11.4.3.

BMC services may be used to announce the creation of a new downlink service.

9.1.2.2 Downlink connectionless procedure description

FT procedure:

The CBC of a downlink service normally transmits continuously, i.e. in one slot every frame (see clause 5.7). The CBC supports the BMC and the CMC downlink service. Dependent on the downlink service (see clause 5.7.2.1) the DLC may deliver CL_S , CL_F , SI_N or SI_P data with a MAC_DOWN_CON-req primitive. During SI_N services the DLC shall submit one segment of SI_N channel data per frame. During SI_P services the DLC shall submit the maximum number of SI_P segments that can be transmitted in one frame. For CL_F services the DLC may submit at most the maximum number of CL_F segments that can be transmitted in one frame. In addition the DLC may deliver one segment of CL_S data every second frame.

CL_S data is transmitted by the RFP strictly following the T-MUX rules defined in clause 6.2.2.1. No numbering is applied for CL_S segments. The TA bits in the A-field header may use either code for C_T tails.

CL_F data is positioned in the B-field according to the definition in clause 6.2.2.3.

PT Procedure:

Predicate: The PT has a CBC installed and is receiving the FT's connectionless bearer.

NOTE: The FT's connectionless downlink transmissions can be recognized by the special header coding for the N_T tails. In addition, the FT may use the BMC service to broadcast the connectionless bearer position.

The PT's CMC delivers all connectionless data together with the CRC results to the DLC using the MAC_DOWN_CON-ind primitive. If the A-field was received with errors any B-field data shall be delivered with data type set to "unknown". The A-field tail shall be delivered as "unknown" on A-field CRC failure only when received in a TDMA frame where C_T tails in the downlink direction are allowed (see clause 6.2.2.1).

9.1.3 Paging broadcast procedure

In clause 9.1.3 the following definitions shall apply:

- if "length of page field" = 0, the page is "zero length";
- if "length of page field" = 20, the page is "short";
- if "length of page field" = 36, the page is "full"; and
- if "length of page field" > 36, the page is "long".

9.1.3.1 RFP paging broadcasts

Paging messages are used to alert a PP at any location within a DECT fixed part. The B_S channel is handled by the broadcast message controller and the broadcast controllers in every TBC, CBC, and DBC.

The BMC in each cluster shall check that the "cluster ID" parameter in the MAC_PAGE-req primitive refers to the BMC's cluster. Zero length, short, full, long and resume pages are distinguished by their different SDU length and the "long" flag for SDU length 36.

All paging messages are broadcast by an RFP using the P_T type tails. Within one cluster, all B_S channel information shall be duplicated in the P_T type tails of all bearers.

The BMC shall not generate a P_T type tail containing short, full, or long page information except after having received a MAC_PAGE-req primitive. Zero length pages may be generated either after receiving a MAC_PAGE-req primitive with "length of page field" = 0, or by the broadcast controller in the TBC, CBC, or DBC itself. Resume paging messages are generated by the broadcast controller in the DBC or CBC when need for resumption of a suspended connection is identified in the FT.

Zero length page messages are allowed in every frame where P_T information is allowed. Normal length page messages with B_S data and resume page shall have priority over zero length page messages.

NOTE 1: Care has to be taken not to force the PPs which are operating in low power mode to listen to all page messages. This can be done by deactivation of the page-extend bit.

The MAC_PAGE-req primitive shall define one of two possible paging types:

- normal paging;
- fast paging.

NOTE 1a: In the case of resume paging the decision of which paging type will be used is a MAC internal matter.

P_T type tail transmissions are only allowed in certain frames of the multiframe (see clause 6.2.2.1). Fast paging may only be used to alert PPs that listen to all allowed frames for P_T tails. Normal paging is applied to alert PPs that do not listen to all of these frames. To ensure that PPs have not to listen to all allowed frames for P_T tails within one multiframe but can receive all page tails of the normal paging type transmitted in that multiframe the FT sets an extend flag in the P_T tail header. Paging tails of the normal and fast paging type shall be transmitted within a multiframe according to the following rules.

Fast resume, fast full and fast short paging messages and the first segment of a fast long page message may be placed in any frame in which transmission of P_T type tails is permitted, except that they shall not interrupt long pages.

NOTE 2: Higher layer functions are used to ascertain whether a PT is likely to respond to fast paging.

Fast zero length pages shall be treated as normal, zero length pages. Normal resume, normal full, normal short and normal zero length paging messages and the first segment of a normal long page message shall be restricted to the following frames:

- a) frame 0 in any multiframe sequence;
- b) frame 2, only if frame 0 has the extend flag set to 1;
- c) frame 4, only if frames 0, 2 have the extend flag set to 1;
- d) frame 6, only if frames 0, 2, 4 have the extend flag set to 1;
- e) frame 10, only if frames 0, 2, 4, 6 have the extend flag set to 1;
- f) frame 12, only if frames 0, 2, 4, 6, 10 have the extend flag set to 1.

In frame 12, the extend flag shall be set to 0.

Long pages shall have the extend flag set to 0.

NOTE 3: Within one multiframe, at most one long page of the normal paging type may be transmitted, and this is the last transmitted page of the normal paging type for that multiframe.

Long pages are divided into segments of 36 bits and shall be transmitted in successive frames in which P_T type tails are permitted. Long pages shall not continue from frame 12 to frame 0.

Every P_T tail contains a 4 bit header. One bit is the extend flag, referred to above. The other three bits in this header indicate the length of the page and, in the case of a long page, the segment transmitted. For the B_S SDU length 36 two codes are used to distinguish full and long pages. Pages longer than 36 bits make use of three codes, one indicating "the first 36 bits of a long page" another "not the last 36 bits of a long page", and the other indicating "the last 36 bits of a long page".

Resume pages contain the ECN and the PMID.

Short pages contain 2 bytes of MAC layer information. Zero length pages contain 20 bits of RFP identity and then 2 bytes of MAC layer information. See clause 7.2.4 for the format of the P_T messages. The broadcast controller in each TBC, CBC or DBC decides which type of MAC layer information is placed in the two byte field, and the information shall be specific to that RFP.

The BMC shall at least distribute full and resume pages to the broadcast controllers in TBCs, CBCs and DBCs for transmission in frame 0. The BMC need not distribute pages to the broadcast controllers in TBCs, CBCs, and DBCs for transmission in frames other than frame 0.

The broadcast controller in a TBC, CBC or DBC shall transmit the P_T type tail distributed to it by the BMC in the frame indicated by the BMC.

The MAC layer shall transmit an N_T type tail in frame 0 at least once every T205 seconds.

NOTE 4: FPs that allow PPs to enter into low duty cycle Idle_Locked mode (see clause 11.3.3) should transmit an N_T type tail in frame 0 of at least four multiframe every T205 seconds. The multiframe selected for these transmissions should be selected with care to ensure that all locked PPs can receive the N_T type tail. The FP that allows low duty cycle paging should also select the moment of transmitting MAC control paging (in any of 4 multiframe) such that all information can be received by a PP which is receiving only once.

The BMC shall not supply the bearers in its cluster with page messages that are older than T204 multiframe, measured from the time instant when the MAC_PAGE-req primitive was received. This limits the lifetime of a page message in the MAC layer.

NOTE 5: This limit applies to MAC layer repeats as well as to initial transmissions.

"Long" pages shall be issued by a cluster's BMC to all TBCs, CBCs and DBCs not more than once.

For FPs that do not allow PPs to enter into low duty cycle Idle_Locked mode (see clause 11.3.3) and provided that capacity is available and the lifetime of the page information in the MAC layer has not expired, then "resume", "short" and "full" pages shall be issued by the BMC at least once and may be repeated at most three times. New page messages have priority over repetitions.

For FPs that allow the PPs to enter into low duty cycle Idle_Locked mode, provided that capacity is available and the lifetime of the page information in the MAC layer has not expired, the BMC shall issue "resume", "short" and "full" pages for a first transmission to all TBCs, CBCs and DBCs. The BMC shall repeat the transmission of "resume", "short" and "full" page messages in the three multiframe following the first transmission of the messages, provided that the MAC layer lifetime has not expired. Repeats of page messages have priority over first transmissions of new page messages.

NOTE 6: MAC control added to short page messages (see clause 7.2.4) need not be the same for all repetitions.

NOTE 7: The FP broadcasts within the "fixed part capabilities" message (see clause 7.2.3.4) whether or not PPs are allowed to enter the low duty cycle Idle_Locked mode.

The normal and the fast paging may be combined, so that FPs could allow the PPs to enter into low duty cycle Idle_Locked mode by using the normal paging type and FPs could allow PPs that will stay in the high duty cycle Idle_Locked mode to establish the connection rapidly by using the fast paging type additionally.

9.1.3.2 PP paging procedures

9.1.3.2.1 PP paging detection

Idle_Locked is the normal state of a PP between calls. In this state the PP maintains synchronism with at least one RFP by receiving regularly P_T or N_T type tail messages on any bearer from an RFP. The frequency of the reception depends on the Idle_Locked mode:

- high duty cycle Idle_Locked mode;
- normal Idle_Locked mode;
- low duty cycle Idle_Locked mode.

These modes are described in clause 11.3.3 and define the ability to receive page messages.

9.1.3.2.2 PP paging processing

The extend flag should be used to extend normal page detection, irrespective of the CRC result (pass or fail).

The various lengths of page fields shall be handled as follows:

Resume page: the PT shall attempt to resume the operation of the connection identified by the ECN received in the paging message and shall start bearer establishment by sending a Bearer_Request (advanced, ECN= the true ECN related to the connection to be resumed, i.e. the ECN received in the MAC resume page message); MAC_PAGE-ind primitive shall not be issued.

Zero length page: a MAC_PAGE-ind primitive shall not be issued. The contents of the P_T tail may be used by the portable termination.

Short and full page: the complete B_S channel SDUs should be delivered to the higher layer, irrespective of the CRC result (pass or fail) with a MAC_PAGE-ind primitive. For short pages the rest of the information in the P_T tail may be used by the PT.

Long page: the complete B_S channel SDU of a long page should be delivered to the higher layer with a MAC_PAGE-ind primitive, provided that all parts of the message (see clause 9.1.3.1) are received without error (CRC passed).

NOTE 1: The BMC in the PT may assemble a complete message from receptions on several bearers. However during reception of a long page message the PT should not lock to another RFP; it should wait until the end of the long page message has been detected because on different RFPs the page messages are not necessarily synchronized.

NOTE 2: Bearers from different RFPs may carry different page messages, but the page messages are the same for all RFPs belonging to one cluster.

9.2 Uplink connectionless procedures

9.2.1 General

This procedure allows the DLC layer in a PT to send a short protected message to the DLC layer in the FT. The PT's MAC layer may use a random access technique to select when to transmit the message.

To provide protection, the PT's MAC layer adds CRCs to the higher layer data.

The connectionless uplink service consists of one or two transmissions on a selected C/L uplink bearer. For connectionless uplink services the number of transmissions from a single PT shall not exceed N203 for any period of T215 multiframes.

Segment numbering is not defined for this service.

9.2.2 Bearer selection for the connectionless uplink

The "standard capabilities" Q_T message shall indicate whether an FT offers the connectionless uplink service. If it does not provide this service, the PT shall not attempt to make connectionless uplink transmissions. If a "connectionless uplink" service is provided, but C_F messages are not supported, the PT's MAC layer shall not attempt to transmit CL_F data.

When no C_F channel is supported at the FT (see "standard capabilities", clause 7.2.3.4.2) and a PT's MAC layer receives a MAC_UP_CON -req primitive containing CL_F segments, the PT shall respond with a MAC_UP_CON -cfm primitive with the status parameter set to " CL_F not supported".

For RFPs of an FP which supports the C/L uplink service (see "fixed part capabilities", clause 7.2.3.4), the TDD pair of any dummy or C/L downlink bearer shall be considered as a C/L uplink bearer, i.e. the RFPs listen to the allocated channel in all TDMA frames.

If a dummy bearer or a connectionless downlink bearer can be found within T214 frames after receiving a MAC_UP_CON -req primitive, the PT shall use the TDD pair of this bearer. Otherwise the PT shall select a channel for the uplink service according to the procedure defined in clause 11.4.2.

NOTE 1: An RFP may provide one dummy bearer when traffic bearers are present. If a connectionless downlink service is needed this dummy bearer is converted to a connectionless bearer and is the only bearer at the RFP which supports the C/L downlink service. RFPs may broadcast the position of a permanent broadcast or connectionless bearer using the BMC service (P_T tail).

NOTE 2: At least one dummy bearer is always maintained when no traffic or connectionless bearer for downlink transmissions exist.

A dummy bearer is marked as a short bearer (no B-field) in the BA field of the A-field header and uses the normal identification for N_T tails.

A connectionless downlink bearer is marked by using a special identification for N_T tails.

9.2.3 Procedure for the connectionless uplink

9.2.3.1 Predicates

- 1) The PT shall be in the Idle_Locked or Active_Locked state.
- 2) The PT shall know of at least one bearer suitable for an uplink connectionless transmission (see clause 9.2.2).
- 3) The PT knows the FMID of a suitable RFP.
- 4) The PT has a CBC installed.

9.2.3.2 PT D-field construction

When the PT's MAC layer receives a MAC_UP_CON -req primitive it constructs one or two D-fields to be transmitted by its physical layer.

The A-field of the first D-field contains the "first PT transmission" TA bits; FMID; PMID; and a byte identifying the connectionless uplink service (see clause 7.2.5.6).

For the CL_F service as many CL_F segments as possible are placed in the B-field, and MAC layer CRCs are added. Segments of CL_F data are positioned according to the rules of clause 6.2.2.3.

If the SDU length is 0 (only PMID exchange) or 40 bits (CL_S service), the B-field may be filled in any manner with the BA code in the A-field header = 000, or need not even be transmitted at all with the BA code = 111.

A second D-field shall be constructed for CL_F services with 11 to 20 segments in double slot mode, with 9 to 16 CL_F segments in long slot ($j=640/672$) mode, with 5 to 8 CL_F segments in full slot mode, or with 2 CL_F segments in half slot mode, and for the CL_S service.

For the CL_S service the TA bits in the second D-field indicate data from the CL_S channel by using either of the C_T tail coding and place the SDU in the tail.

For the CL_F services the A-field shall contain a M_T tail identifying the second transmission of a connectionless uplink service (see clause 7.2.5.6).

9.2.3.3 PT transmission sequence

Transmission sequence of the PT's CBC depends on the channel selection criteria:

- a) the selected channel is the TDD pair of a connectionless downlink or a dummy bearer;
- b) the PT selected a free channel.

Case a)

- The transmission sequences are different for C/L uplink services using one or two transmissions:
 - 1) One transmission:
 - the PT sends the D-field in an arbitrarily chosen frame.
 - 2) Two transmissions:
 - the PT sends the first D-field in an arbitrarily chosen frame, and the second D-field on the same channel in the next TDMA frame.

NOTE 1: The uplink channel on the TDD pair of a dummy or C/L downlink bearer is not checked prior to transmission.

NOTE 2: Controlled by the higher layers retransmissions of the same C/L uplink data may occur. To prevent continuous collisions (e.g. two PTs start transmission in the same TDMA frame and use the same retransmission algorithm in their higher layers), the MAC layer should choose a random delay between receiving a MAC_UP_CON-req primitive and the beginning of the first transmission.

Case b)

- After selecting the channel (see clause 11.4) the PT sends the first D-field in any frame in time with the primary receiver scan of the FT.
- If the connectionless uplink service consists of two transmissions the PT sends the second D-field on the same channel in the next TDMA frame.

9.2.3.4 FT procedure

The FT may receive a C/L uplink transmission either on the TDD half of its dummy or connectionless downlink bearer, or by scanning for PT first transmissions. When receiving a PT's C/L uplink transmission marked as "first PP transmission" (see clause 7.1.2) with correct A-field CRC and containing the FT's FMID, the FT shall install a CBC to process the C/L uplink service.

The FT shall decide upon the coding of the M_T tail message (see clause 7.2.5.6) whether the PT uses a single transmission uplink service or a double transmission uplink service. If a double transmission uplink service is in progress the FT's CBC shall receive the second transmission in the next TDMA frame on the same connectionless uplink bearer.

If all data related to the C/L uplink service has been received correctly, i.e. with correct CRCs, the CMC issues a MAC_UP_CON-ind primitive to the DLC with the SDU containing received CL_F or CL_S data.

9.3 Non-continuous broadcast procedure

A-field and B-field procedures exist which allow PTs to acquire more Q channel information and as a further BMC service to request a new dummy bearer.

9.3.1 Request for specific Q channel information

A PT may acquire extended system information upon request. The procedure is initiated by the PT's LLME (see clause 11.2.1).

9.3.1.1 A-field procedure

PT procedure:

The PT creates two D-fields to be transmitted by its physical layer. The B-field of both transmissions may be filled in any manner or need not even be transmitted at all.

The A-field of the first D-field contains the "first PT transmission" TA bits, FMID, PMID, and a byte identifying the service (extended system information; see clause 7.2.5.6).

The A-field of the second D-field contains the M_T tail TA bits and the request in the A-field tail (see clause 7.2.5.10).

The PT selects a channel according to the rules for duplex bearers (see clause 11.4) and sends the first D-field in any frame in time with the primary receiver scan of the FT. The PT transmits the second D-field on the same channel in the next TDMA frame.

The PT then listens to the TDD pair of the bearer until a reply is received or time-out expires (T206, see clause 11.2.2).

FT procedure:

An FT receiving an extended system information request issues the request to the LLME (see clause 11.2.2). If the LLME replies the FT creates two D-fields to be transmitted. The B-field of both transmissions may be filled in any manner or need not even be transmitted at all.

The A-field header of both transmissions uses the M_T tail TA bits.

The first A-field tail contains FMID, PMID, and a byte identifying the service (extended system information; see clause 7.2.5.6).

The second A-field tail contains the FT response (see clause 7.2.5.10).

The RFP selects the TDD pair of that channel on which the request was received and transmits the D-fields in two successive frames. The first D-field may be transmitted in any frame.

9.3.1.2 B-field procedure

PT procedure:

The PT creates one single D-field for the request. This D-field is marked as a "first PT transmission" in the A-field header. The A-field tail contains a special M_T tail identifying the transmission as part of the extended system information service. The B-field contains the request(s) (see clause 7.3.5).

The PT selects a free channel according to the rules for duplex bearers (see clause 11.4.2) and transmits the D-field in any frame in time with the primary receiver scan of the FT. The PT then scans the TDD pair of the bearer until a reply is received or time-out expires (T206, see clause 11.2.2). A reply is marked with the same M_T tail as used for the request. Replies are delivered to the LLME (see clause 11.2.1).

FT procedure:

An FT receiving an extended system information request issues the request to the LLME (see clause 11.2.2). If the LLME replies the FT creates one D-field with the A-field containing an M_T tail. This tail identifies the D-field as part of the extended system information service (see clause 7.2.5.6). The B-field contains the response from the LLME.

The RFP selects the TDD pair of that channel on which the request was received and transmits the D-field once on this channel in any frame.

9.3.2 Request for a new dummy bearer

A PT may request the continuous BMC service on a new dummy bearer. The PT, therefore, selects a channel according to the rules defined in clause 11.4 and prepares one single D-field. The D-field contains an A-field with an M_T tail identifying the service (see clause 7.2.5.6). The D-field is marked as "first PT transmission" (see clause 7.1.2). The B-field may be filled in any manner or need not even be transmitted at all. The PT transmits the D-field in any frame in time with the primary receiver scan of the FT on the selected channel.

The FT may ignore the PT's request or install the dummy bearer on the TDD half of that channel on which the request was received. A PT shall not attempt to change the dummy bearer position at an RFP after two successive unsuccessful attempts to this RFP.

9.4 "No-emission" mode procedures

This clause defines the procedures, which are required for the operation of the "no-emission" mode.

9.4.1 Initiation of the "no-emission" mode

9.4.1.1 Successful activation (countdown to zero)

After being in idle-state for a certain time and if all registered PTs are capable of "no-emission" mode and the mode is permitted, then the FT will start the powerdown-negotiation with all PTs.

The negotiation is done indirectly, because the FT will start a countdown-timer, which is sent in the dummy-bearer using a Pt-Mac-Message defined in clause 7.2.4.3.7.

To avoid collisions between usual Pt-mac-info-transmissions/multiplexing, this countdown-message will be sent in frame 0, but having the extend-flag set, if needed to keep the PTs listening for the following frame where "normal" idle Pt-mac info will be provided.

The multiframe counter increment occurs, when then framecounter steps from 15 to 0. In "no-emission" mode activation phase the paging info "multiframe countdown" shall be sent in every multiframe. This ensures that a PT in low duty mode receives this paging info. It is recommended to send the paging info "idle-scan carrier number" in the same multiframe (use extend flag to send more page frames, see clause 7.2.4.2.2).

If a PT receives the Pt "multiframe countdown", it shall enter the normal duty mode (receive at least in frame 0 every multiframe), to ensure receiving all paging countdown infos (especially value=0).

When the countdown expires and after the last countdown value = 0 has been sent, all transmitters are turned off and every device will fall into a special idle scanning mode as defined in clause 11.11.

NOTE: The system will change into "no-emission" mode without an active point-to-point negotiation with the PTs.

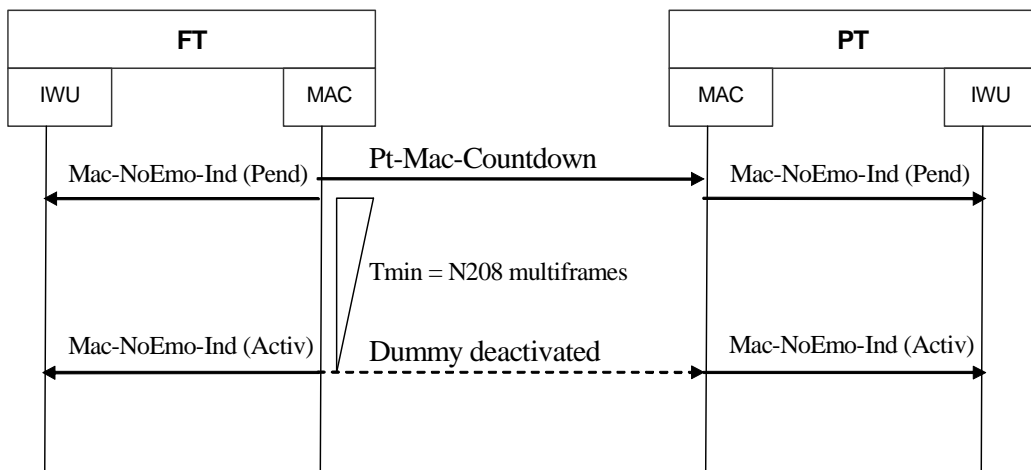

Figure 9.1: Successful activation of "no-emission" mode

9.4.1.2 Multiframe countdown stopped by FT

The FT can stop the multiframe countdown by broadcasting the Pt-MAC "countdown-stopped" value as defined in clause 7.2.4.3.7. The Pt-MAC "countdown-stopped" shall be sent in at least N209 multiframe.

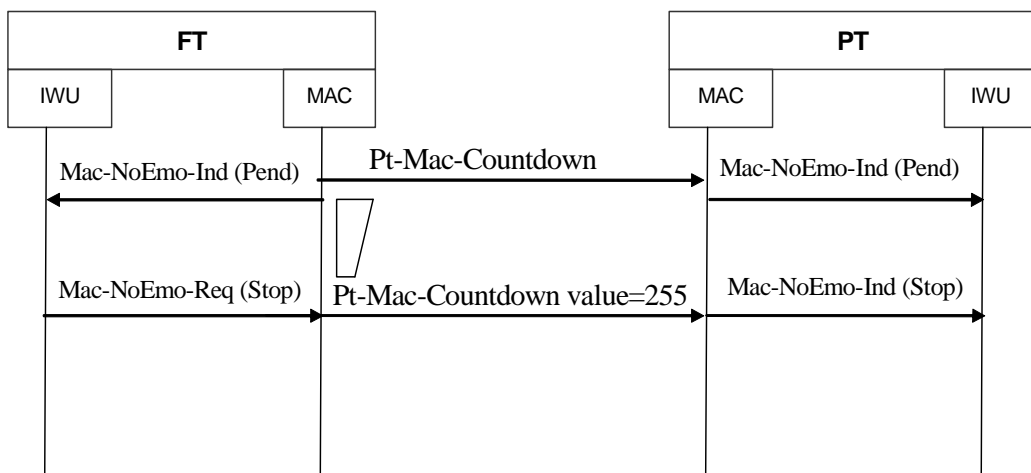

Figure 9.2: Countdown stopped by FT

9.4.1.3 Multiframe countdown stopped by PT

By means of the countdown-timer the PTs can determine the exact time, when power off will be activated and the fact, that power off will be activated soon. PTs can avoid the deactivation of the dummy-bearer by setting up a connection. The FT will then stop the countdown immediately and broadcast in the P_T channel, the "bearer handover/replacement and no-emission mode information" (see clause 7.2.4.3.7) with the info type "number of multiframe until dummy-bearer is deactivated" set to "countdown-stopped" value (255). The P_T broadcast with the "countdown-stopped" value shall be sent in at least N209 multiframe.

NOTE: Besides setting up a mac-connection to avoid "no-emission" mode, the PT can disable the feature by sending the "no-emission" support capability in the terminal capabilities during subscription or location registration at anytime during normal operation as defined in EN 300 175-5 [5].

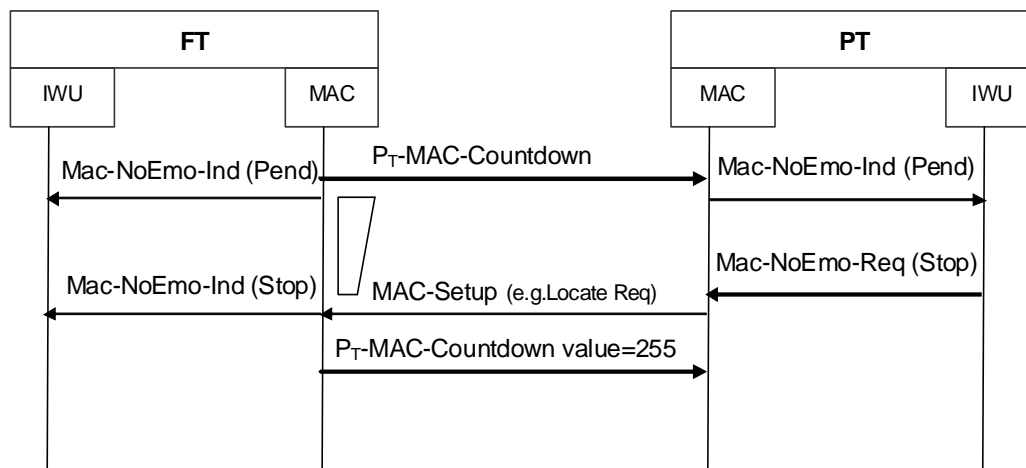

Figure 9.3: Countdown stopped by PT

9.4.1.4 PT does not receive multiframe countdown "zero"

If the FT has started the multiframe countdown and the PT expects, but does not receive the frame where the countdown is "zero", then the state is ambiguous for it ("no-emission", normal operation or being out of range) and the PT shall perform the following operations:

The PT shall perform a normal FT-scan:

- a) If the PT receives an FT transmission, then the state is normal operation.
- b) If the PT does not receive an FT transmission, then the PT shall issue a wakeup call:
 - b1) If the PT receives an FT transmission, then the state is normal operation.
 - b2) If the PT does not receive an FT transmission, then the state is out of range.

If the resulting state is out of range, then the PT should perform the above steps on a regular basis.

9.4.2 Behaviour during power-down-mode

This procedure is defined in clause 11.11.

9.4.3 Waking up, FT initiated

If due to e.g. an incoming call, the FT wants to wakeup the PTs in order to resume normal operation, the FT shall perform a channel selection in order to establish a dummy bearer and (for a short time) one or more DummyPointer.

The FT shall select a suitable channel and setup (in the TX-half-frame) an extended dummy bearer containing sync-information in the B-field. This dummy bearer sends the normal T-Mux in the A-field and 1 protected subfield (SyncSubfield) after the A-field-CRC, which exists only during the wakeup phase. This dummy bearer can be sent on the preferred carrier or on every other available carrier.

In addition the FT shall select one or more suitable slots on the preferred carrier. The selection should be such, that "longer" slot types are selected (instead of the shorter dummy-slots). It is recommended to use full (or long slots), because more DummyPointer can be inserted (see below). Every slot on the preferred carrier that is sufficiently unoccupied and selectable in RX and TX-half may be used to send a DummyPointer. The selected full-(/long)-slots shall contain at least 2 (3 respectively) DummyPointers, that send only N-frames in the A-field, and carry extended sync-information (XSync) after the A-field-CRC. The DummyPointer has a special T-header coding (see clause 7.1.2) to distinguish it from the normal dummy bearer.

The slot-format "full" or "long" is used only as a container for DummyPointer, the receiving side does not necessarily need to support the extended format as such. Reception as fullslot is recommended, e.g. to double-check the received information, if available.

Example: full slot contains 3 DummyPointer:

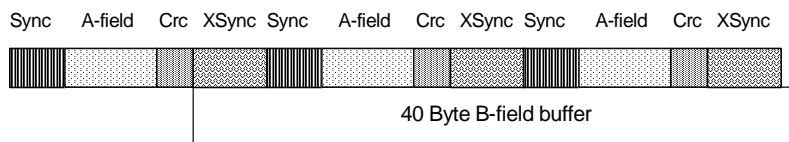

Example: full slot contains 2 DummyPointer:



Figure 9.4: Example: full slot contains 2 or 3 DummyPointer

Example: full slot contains **normal** dummy incl. SyncSubfield and 1 DummyPointer:

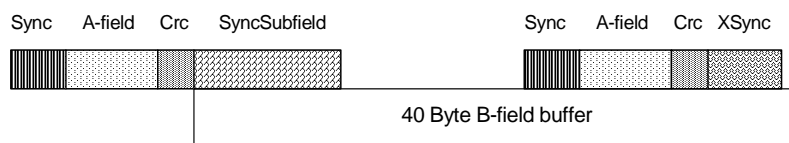
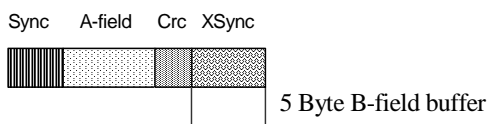

Figure 9.5: Example: full slot contains normal dummy

NOTE: The example in figure 9.5 shows a very specific case where the dummy bearer (incl. SyncSubfield) is transmitted on the same carrier (= preferred carrier) as the subsequent DummyPointer (incl. XSync).

It is also possible to use "smaller" slot types to insert only 1 dummy bearer with additive syncinfos.

Example: "smaller" slot type (using P00j with j=40) for 1 DummyPointer:



Example: "smaller" slot type (using P00j with j=80) for 1 normal dummy incl SyncSubfield:

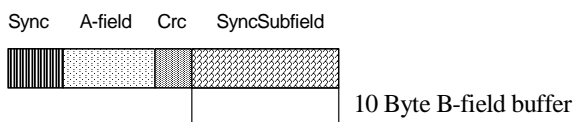

Figure 9.6: Example: slot type P00j with j=40 and j=80

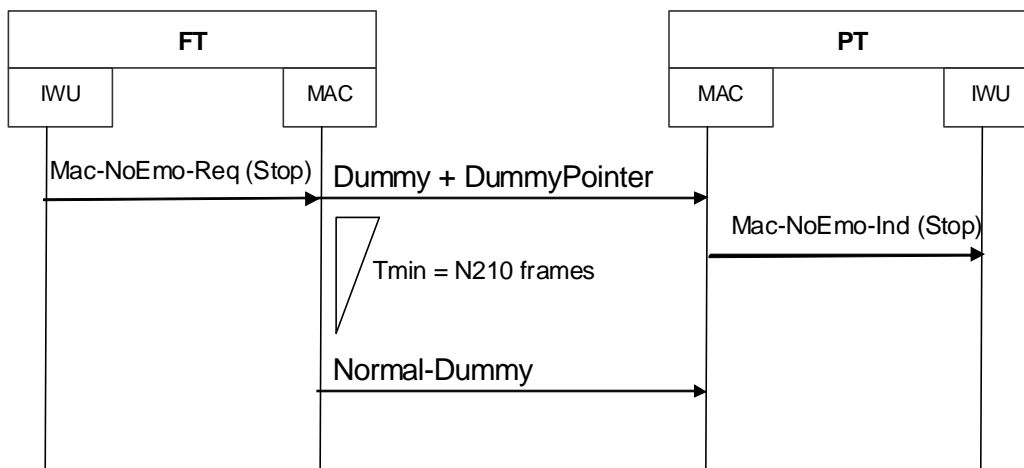

Figure 9.7: FT initiated waking up

Table 9.1: Coding of DummyPointer incl. XSync (FT --> PT)

	Syncfield	A-field		XSync	
		header	A-field+CRC	XSync-Info	Chksum
bitcount	S0...31	A0...7	A8...63	B0...23	B24...39
content	AAAAE98A	0x4E (Nt-DummyPointer)	N-Frame, CRC16	3 byte, see below	CRC16
bytecount	0...3	4	5...11	12...14	15...16

Description of the fields:**Chksum:**

16 bit checksum, calculated from $B_0 \dots B_{23}$.

Table 9.2: Coding XSync-Info

	LockChannel				DummyPointer-Info	
	$B_0 \dots B_1$	$B_2 \dots B_7$	$B_8 \dots B_{11}$	$B_{12} \dots B_{15}$	$B_{16} \dots B_{18}$	$B_{19} \dots B_{23}$
content	0	CN	Slot	0	Position	Slot
bytecount	12		13		14	

Description of the fields:**LockChannel-Slot:**

Slot number of the standard-dummy. (coding: see clause 7.2.3.2.3).

LockChannel-CN:

Carrier number of the standard-dummy. (coding: see clause 7.2.3.2.10).

DummyPointerInfo-Position:

Multiple DummyPointer can be placed in 1 full/long-slot, this SyncInfo indicates which position the current DummyPointer actually has inside the slot.

Table 9.3: Position

Sync-Info B ₁₆ ...B ₁₈	Position of s0 in relation to f0
0 0 0	f0
0 0 1	f136
0 1 0	f272
0 1 1	f408
1 0 0	f544
1 0 1	f680
1 1 0	f240 (halfslot-boundary)
1 1 1	Reserved

Description of the fields:**DummyPointerInfo-Slot:**

Indicates slot (0...23) of this DummyPointer.

Table 9.4: Coding of normal DummyBearer incl. SyncSubfield (FT --> PT)

	Syncfield	A-field		SyncSubfield	
		header	A-field+CRC	SyncSubfield-Info	Checksum
bitcount	S0...31	A0...7	A8...63	B0...63	B64...79
content	AAAAE98A	Tail-header, BA-bits=110	T-Mux, CRC16	8 byte, see clause 7.3.5.3	CRC16
bytecount	0...3	4	5...11	12...19	20...21

Description of the fields:**Checksum:**

16 bit subfield checksum, calculated from B0...B63.

Transmitting side (FT):

DummyPointer and SyncSubfield inside the B-field require the scrambler to be switched off, otherwise the receiving side cannot decode them. No X-CRC should be transmitted after the XSync of the DummyPointer and after the SyncSubfield of the normal dummy bearer.

Receiving side (PT):

The Tail-header (see clause 7.1.2) has to be checked to distinguish between a DummyPointer and the normal dummy bearer.

- a) If a DummyPointer was received, the XSync-infos can be evaluated and make it possible to adjust the receiver directly to the normal dummy receiver. The X-CRC shall be ignored.
- b) If the normal dummy bearer was received, the SyncSubfield-infos can be evaluated and make it possible to get synchronous in a very short time. The X-CRC shall be ignored.

By providing this additional synchronization-information, the PT is able to collect all required settings to get synchronous within a single burst. Static information like physical and higher-layer capabilities can be kept from before power-down got active.

After successful reception of the burst, the PT will synchronize bit, slot and frame-counters and establish the normal dummy-bearer receiver on the indicated lock-channel.

The FT shall maintain the DummyPointer-phase for up to N210 frames, but not less than N210/2 frames. During this time the DummyPointer block potential setup-slots. So it is recommended to keep open one or more receive-slots for setups during this phase, to allow at least one quick setup. If receive-slots would be blocked for longer, setup-timers in the PTs might be timing out and the setup would be lost.

Behaviour after Reset:

After reset, the FT shall always start with a "no-emission" wake-up-call on the preferred carrier or on all available carriers (depends on MAC layer capability part2, bit a₂₃), because there might have been e.g. a power failure that led to an unwanted restart of the FT. The FT does not know, whether it was in "no-emission" mode before or not. So possibly PTs are in "no-emission" mode without even noticing, that the status of the FT has changed.

9.4.4 Waking up, PT initiated

If a PT wants to end "no-emission" mode, the PT shall perform a channel selection in order to establish one or more DummyRequests on the preferred carrier. They are quite similar to the DummyPointer of the FT, but have another syncfield-coding (PT-syncfield-coding) and no extended sync-information. Therefore all DECT devices can distinguish whether a DummyRequest is sent from a PT or a DummyPointer is sent from an FT.

Table 9.5: Coding of DummyRequest (PT --> FT)

	Syncfield	A-field	
		header	A-field+CRC
bitcount	S0...31	A0...7	A8...63
content	55551675	0x6E (Nt-Info)	N-Frame, CRC16
bytecount	0...3	4	5...11

"N-Frame" contains the RFPI of the FT that should be awoken.

The PT provides no further sync-information. More DummyRequests may be put into a fullslot to achieve a higher probability for the FT to receive it.

NOTE: One fullslot can contain up to 3 additional DummyRequests in the B-field. One longslot can contain up to 6 additional DummyRequests in the B-field.

The PT shall setup the DummyRequest up to N211 frames, but not less than N211/4 frames. The FT shall start transmission of its own DummyPointer in reply, immediately after the DummyRequest-transmission of the PT ends. The initiating PT then shall revert to scanning mode, like the other PTs.

After this, the synchronizing sequence continues exactly like clause 9.4.3 "Waking up, FT initiated".

Doing so, there is no need to implement synchronization-mechanisms in the FT, and PTs do not need to be able to receive other PTs DummyRequests and behave differently.

Behaviour after Reset and during asynchronous mode:

After reset and during asynchronous mode, the PT, if subscribed to a "no-emission" FT, should start normal scanning. If the FT cannot be found, the PT should issue a "no-emission" wake-up-call on the preferred carrier or on all available carriers (depends on MAC layer capability part2, bit a₂₃).

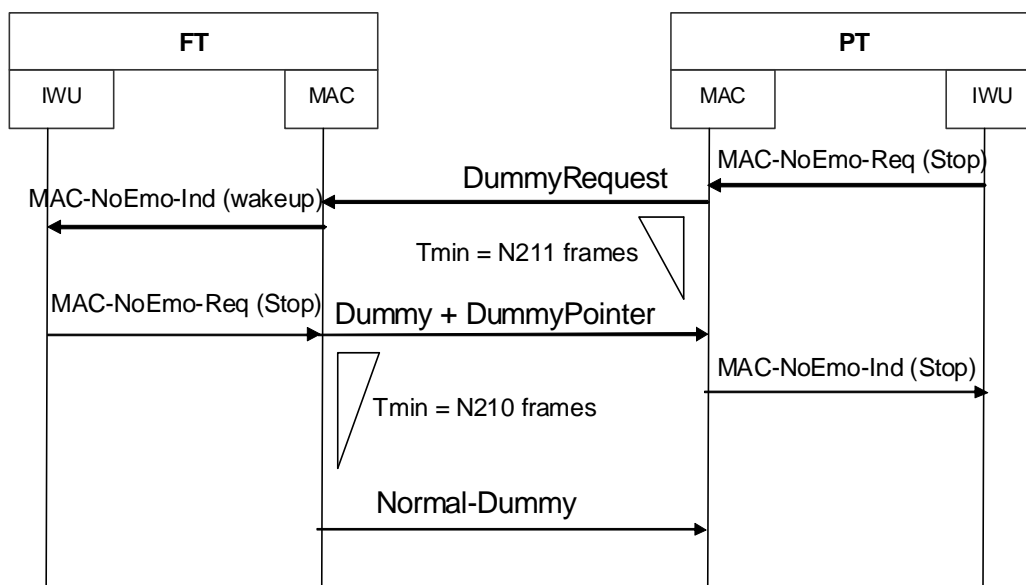

Figure 9.8: PT initiated waking up

9.5 Ultra Low Energy (ULE) Mode Procedures

This clause defines the procedures, which are required for the operation of the DECT Ultra Low Energy (ULE) operation mode.

9.5.1 Initiation of the ULE Mode

If a system is deemed to be a ULE capable system and at least one registered PT is capable of ULE mode, then the FT shall start in ULE mode.

The FT shall follow normal channel selection procedures and set up a dummy bearer, the FT has the choice to either setup this dummy as both a normal dummy and a ULE dummy, or optionally to select another channel following the normal channel selection procedure and set up an additional bearer as the ULE dummy.

The definition of the ULE dummy includes the normal dummy bearer with the A-field T-MUX messages so only one ULE dummy is required for all normal operations as well as the ULE functionality.

The ULE dummy is defined with some similarities to the "no emission" mode. Having chosen the suitable channel the FT shall setup (in the TX-half-frame) an extended dummy bearer in a standard full slot containing ULE related information in the B-field. This dummy bearer sends the standard T-MUX in the A-field, but additional information relevant for ULE in the B-field in the protected subfields after the A-field CRC.

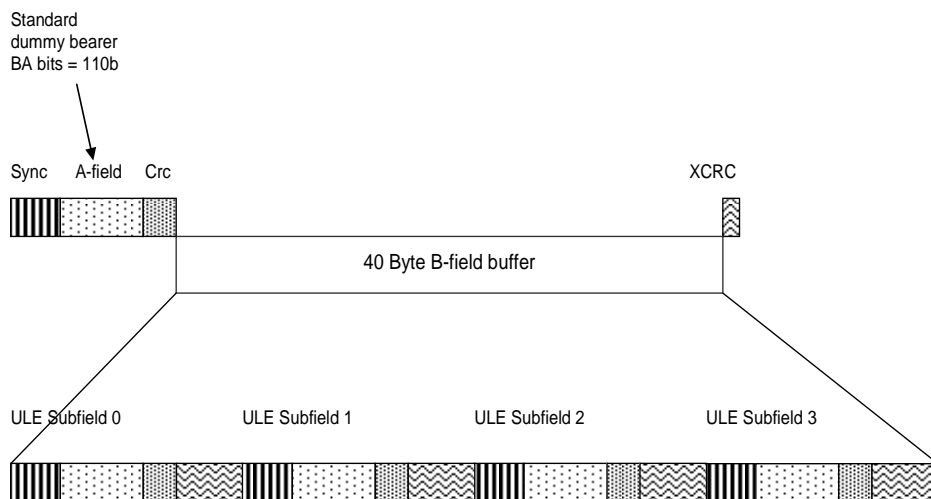

Figure 9.9: ULE Dummy Bearer showing BField data

9.5.1.1 ULE Dummy Bearer Subfield 0

The first sub-field contains the SyncWord subfield, this is the part that ULE PTs search for when trying to gain lock to the ULE FT. It shall contain the following information.

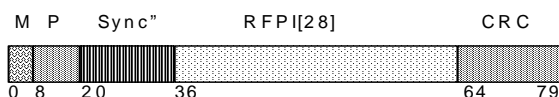

Figure 9.10: ULE Dummy Bearer Subfield 0 - SyncWord Subfield

Table 9.6: Coding of Subfield 0 - SyncWord Subfield

	M (MBn Header)	P	Sync''	RFPI[28]	CRC
bitcount	0...7	8...19	20...35	36...63	64...79
content	X1001010	101010101010	1110001101100100	28 LSBs of RFPI	Std. 16 bit CRC

NOTE: The standard MBn header of the first protected BField subfield has its last nibble set to replicate the preamble pattern, this is so that the P field can be reduced to 12 bits to save space, but that the PTs still receive the full 16 bit preamble pattern for its RF training purposes.

9.5.1.2 ULE Dummy Bearer Subfield 1



Figure 9.11: ULE Dummy Bearer Subfield 1

Table 9.7: Coding of Subfield 1

	M (MBn Header)	R	SP (Spare)	SFa	SFb	CA	Selectable	CRC
bitcount	80...87	88...99	100...103	104...105	106...107	108...111	112...143	144...159
content	X1001011	12 MSBs of RFPI	0000	Subfield a use	Subfield b use	Channel active		Std. 16 bit CRC

NOTE: The fields SFa and SFb (Subfield Use) indicate what information is carried in certain subfields that have bits that have several meanings. The subfields that are currently referred to are subfield 1 and subfield 3 and the meaning of the information carried in the selectable fields is shown in the table 9.8.

Table 9.8: SF(Y) Field

Subfield Use	Meaning
00	Subfield Y does not carry any information
01	Subfield Y carries paging information
10	Subfield Y carries broadcast information
11	Reserved

NOTE: For subfield 1 the selection determines the meaning of bits 112 to 143.
For subfield 3 the selection determines the meaning of bits 248 to 303.

The bits in subfield 1 that can be selected by the SFa (Subfield Use) field have the following meaning:

Table 9.9: Meaning of Subfield 1 selectable bits

Subfield 1 use	112...143
No info	00000000000000000000000000000000
Paging Info	32 bits bit mapped
Broadcast Info	Data determined by higher layer
NOTE: The data is XORed with the value 00001111000011110000111100001111 before insertion in the message	

The CA Channel Active field is used to indicate that there is/are a broadcast/paging message(s) that devices with a matching active channel in their broadcast/paging channel definition should receive. If these bits indicate that a device has no broadcast/paging message to receive the device can return to power saving mode. There is no bit map definition for these 4 bits. See clause 9.5.1.5 for details of the broadcast/paging channels.

9.5.1.3 ULE Dummy Bearer Subfield 2

**Figure 9.12: ULE Dummy Bearer Subfield 2**

Table 9.10: Coding of Subfield 2

	M (MBn Header)	LS (Lock Slot)	Spare	Counters			ULE MAC Info (M _U)		CRC
bitcount	160...167	168...171	172...173	174...179	180...183	184...207	208...211	212...223	224...239
content	X1000001	Slot number of the present bearer	00	PSCN	Frame counter	Multi-frame counter	Info 1	Info 2	Std. 16 bit CRC

NOTE: Regardless of whether this is the only dummy bearer or there are several the lock slot shall always contain the slot number of the bearer where this message is transmitted.

9.5.1.3.1 M_U Channel Info 1 coding

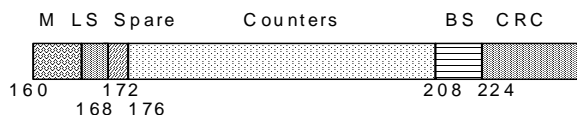
The M_U Info 1 subfield contains the RSSI value that the PT shall use in the channel selection algorithm M1 (see clauses 11.12.4 and 11.12.5 in the present document). The value is coded as shown in table 9.11.

Table 9.11: M_U Channel Info 1 Meaning

Info Type	Meaning	Description
0000 - 0100	Reserved	
0101	-33 dBm	The threshold to be used in algorithm M1 shall be -33 dBm
0110	-39 dBm	The threshold to be used in algorithm M1 shall be -39 dBm
0111	-45 dBm	The threshold to be used in algorithm M1 shall be -45 dBm
1000	-51 dBm	The threshold to be used in algorithm M1 shall be -51 dBm
1001	-57 dBm	The threshold to be used in algorithm M1 shall be -57 dBm
1010	-63 dBm	The threshold to be used in algorithm M1 shall be -63 dBm
1011	-69 dBm	The threshold to be used in algorithm M1 shall be -69 dBm
1100	-75 dBm	The threshold to be used in algorithm M1 shall be -75 dBm
1101	-81 dBm	The threshold to be used in algorithm M1 shall be -81 dBm
1110	-87 dBm	The threshold to be used in algorithm M1 shall be -87 dBm
1111	-93 dBm	The threshold to be used in algorithm M1 shall be -93 dBm

9.5.1.3.2 M_U Channel Info 2 coding

The Info 2 field contains 12 bits indicating if a given slot pair is considered available by the FT. The format is the same as the blind slot information in the MAC info (see clause 7.2.4.3.2). A value of 1 indicates that the slot pair is available to be used by the channel selection process M1 (see clauses 11.12.4 and 11.12.5 in the present document).

9.5.1.4 ULE Dummy Bearer Subfield 3

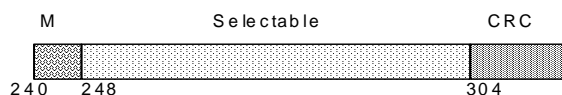

Figure 9.13: ULE Dummy Bearer Subfield 3

Table 9.12: Coding of Subfield 3

	M (MBn Header)	Contents	CRC
bitcount	240...247	248...303	304...239
content	X1000010	Meaning determined By setting in subfield 1 See clause 9.5.1.2	Std. 16 bit CRC

The bits in subfield 3 that can be selected by the SFb (Subfield Use) field in subfield 1 have the following meaning.

Table 9.13: Meaning of Subfield 3 selectable bits

Subfield 3 use	248...303
No info	00
Paging Info	56 bits bit mapped
Broadcast Info	Data determined by higher layer
NOTE: the data is XORed with the value 00001111000011110000111100001111000011110000111100001111 before insertion in the message.	

9.5.1.5 Broadcast/Paging Channels

The bits within the ULE Dummy Bearer are a scarce resource, and to allow for flexibility of use and extendibility, certain subfields have been defined to provide multiple meanings for their contents. The meanings are indicated in the SFa and SFb (SubField Use) field in subfield 1 of the ULE dummy bearer, see clause 9.5.1.2. The exact handling of the broadcast/paging channels is determined by the system in use, how many PTs are subscribed and what type of sensors these devices represent and so is out of the scope of this clause of documentation. However, the mechanism of the operation is described here.

The FT will determine the number of channels it needs in order to perform the tasks of the product and how these should be organised, the details of this scheme are passed to each PT in higher layer messages. The details passed are defined so that the FT can indicate the intended recipient(s) of a particular message.

A Broadcast/Paging channel is defined as starting in a particular frame within a particular Multi-Frame, and repeating at a particular rate, the absolute limit to the number of channels that can be created is for each channel to appear once in the full cycle of available frames (2^{15}), this limit is unlikely to be reached as the more channels there are means the greater the latency for each individual channel. Each channel can then be defined to pass broadcast and/or paging information, each individual message is either a paging message or a broadcast message, the message indicates which is the currently active type. For paging messages, the intended recipient(s) are indicated in the 2 subfields of bit mapped data currently in subfield 1 and subfield 3 of the ULE dummy bearer, the FT allocates and informs the PTs which bit(s) to use. So each device is given which channel(s) to listen to, which bit(s) indicate the message is intended for that device, a mask for the Channel Active field and a parameter to indicate the frequency of the messages. The Channel Active field can only indicate 4 channels, one bit each, which channels are indicated by this field is determined by the FT. If a channel is used that is not indicated by the Channel Active field the PT shall decode the counters to check if any broadcast/paging message is being sent. If the FT sends a broadcast/paging message with bits in the Channel Active field set it means that that channel is actively sending a message and the PT shall check it.

Table 9.14: Channel Description Parameters for Each Channel for PT

Value	Description	Range
Start_MFN	Multi-Frame Number in which the first frame with paging to this channel occurs	0 - 2 047
Start_FCNT	First Frame Count within Multi-Frame Number in which paging to this channel occurs	0 - 15
BroadcastRepetition	Number of Frames between frames of the same broadcast/paging channel, given as exponent of 2	$2^0 - 2^{15}$
Channel Active	Mask to check against the transmitted Channel Active field of a paging/broadcast message, any matching bits indicate this is an intended recipient of the message	0 - 15
BitOffset	Bit within the bit mapped subfields of ULE dummy bearer subfield1 and subfield3 paging message (ignored if broadcast channel) If $0 \leq \text{BitOffset} \leq 32$, then bit is (112 + BitOffset) in bit mapped part of subfield1 If $\text{BitOffset} > 32$, then bit is (248 + BitOffset -32) in bit mapped part of subfield3	0 - 87

This provides a highly flexible broadcast/paging mechanism. The selection of channels and the parameters for those channels will in general be a trade-off between numbers of devices and the maximum latency. For any given channel the maximum number of devices that can be addressed individually is 88.

For examples of the use of this broadcast/paging mechanism see TS 102 939-1 [i.10], clause C.2.

10 Connection oriented service procedures

10.1 Overview

The connection oriented procedures use two peer-to-peer associations: connections and bearers. A connection is the association that is visible to the DLC layer, and each connection uses the services of one or more bearers as described in clause 5.6.

The procedures are described in the following groups:

- Connection control procedures:
 - connection setup (see clause 10.2);
 - connection modification (see clause 10.3);
 - connection release (see clause 10.4).
- Bearer control procedures:
 - bearer setup (see clause 10.5);
 - bearer handover (see clause 10.6);
 - bearer release (see clause 10.7).
- Data transfer (see clause 10.8):
 - CRFP connection control procedures (see clause 10.9).

The procedures are written in the style of a time sequence diagram, with the PT and FT procedures interlaced to represent the order of events. The steps are numbered as a single series, and the varied outcomes are described with a series of lettered substeps (3a, 3b, etc.).

10.2 C/O connection setup

Connection setup is the first phase of a connection orientated MAC service and the first phase of a connection handover. The phrase "Connection_Established" is defined to mean completion of setup at the MAC layer.

Connection setup can be originated from either side. These directions are defined as follows:

- MAC PT_originated;
- MAC FT_originated;
- MAC REP_originated.

All setup attempts for connection handover are PT_originated.

10.2.1 General

There are four connection setup processes:

- basic connection setup process, PT_originated;
- normal (advanced) connection setup process, PT_originated;
- fast connection setup process, FT_originated;
- complementary connection setup process, REP_originated.

The basic setup process is used to set-up a basic connection. The normal and fast setup processes create advanced connections (see clause 5.6).

Expedited connections (see clause 10.2.5) are, for this process, a type of advanced connections, and use normal (advanced) setup procedures for connection creation.

The complementary connection setup process is used to set-up a complementary connection (see clause 10.5.1.5).

10.2.2 Initiation of a basic and a normal connection setup

A basic or normal setup may be initiated by a network layer call that originates from either the PT or FT as detailed in the following overview:

FT-originated call:

- FT higher layer sends a paging command to the PT higher layer;
- if this page is received successfully, the PT higher layer initiates a connection setup by issuing a MAC_CON-req primitive to the PT MAC layer.

PT-originated call:

- the PT higher layer initiates a connection setup by issuing a MAC_CON-req primitive to the PT MAC layer.

10.2.3 Initiation of a fast connection setup

FT-originated call only:

- the FT DLC initiates a connection setup without any prior paging by issuing a MAC_CON-req primitive to the MAC layer. This primitive is addressed to only one RFP and the address of the RFP shall be known in advance.

10.2.4 Connection setup procedure description

10.2.4.1 Creation of MBCs

Calling side:

A connection setup starts with the initiation process, either the DLC in the PT (basic and normal setup) or the DLC in the FT (fast setup) issues a MAC_CON-req primitive to its MAC.

This primitive includes a MAC Connection Endpoint Identifier (MCEI) which is used to identify all further primitives related to this connection.

For fast connection setup the MAC_CON-req primitive shall include the Radio fixed Part Number (RPN) to identify the RFP to which the PT is registered, and the PMID of the called PT. If the wanted RFP cannot be addressed by the MBC the MAC issues a MAC_DIS-ind primitive to the DLC and releases the MBC entity.

NOTE 1a: To allow a particular PT to be addressed, fast setup requires that an assigned PMID of that PT is known beforehand.

If a connection is requested to perform a connection handover the MAC_CON-req primitive shall include the new and the old MCEI.

If a connection is requested that is to be associated with an already established connection for the purposes of a Broadband data link the MAC_CON-req primitive shall include in the "Broadband data link ECN" the ECN of the first established connection.

In addition, the MAC_CON-req primitive shall include the necessary parameters to identify the wanted service. After receiving a paging command the full service description is not always known by the PTs. Then the service has type "unknown".

If the MAC cannot establish a connection (e.g. an advanced connection is needed and the FT only supports basic connections) or the MAC does not support the wanted service (e.g. the MAC only knows basic connections and a data service is wanted) the MAC issues a MAC_DIS-ind primitive to the DLC and releases the MBC ending the procedure.

The MBC asks the LLME for allowance to set-up the connection between the FT (as identified by its ARI) and the PT (as identified by its PMID). If a single bearer I_N -minimum_delay service is wanted and no C_F channel is required the MBC may ask to establish a basic connection, otherwise the MBC asks for an advanced connection (see clause 5.6). If the new connection is for connection handover the MBC also issues the MCEI of the old connection to the LLME.

Whenever an MBC is allowed to establish an advanced connection the LLME assigns the Exchanged Connection Number (ECN) to the MBC. In the case of establishing the second and/or third connection associated with a Broadband data link, the LLME shall use any of the ECNs agreed between the peers and assigned during NWK layer call setup procedure.

The LLME may forbid the establishment of the desired connection (e.g. there already exists a basic connection, no further ECNs available). If a basic connection was requested by the MBC and then prohibited by the LLME, the MBC may reattempt by asking for an advanced connection.

If it is not allowed to set-up the wanted connection the MAC issues a MAC_DIS-ind primitive to the DLC indicating the reason, and releases the MBC.

If the MBC is allowed to set-up the connection the MAC reports the connection type (basic or advanced) with the MAC_CON-cfm primitive to the DLC after the successful setup of the first bearer.

NOTE 1b: In the case of a successful connection setup there exists a common identification for the connection known at both, PT and FT. It consists of ARI + PMID (+ ECN) where the ECN only appears for advanced connections. For advanced connections this identification is always unique within the PT and the FT. For basic connections a duplication may occur only during connection handover.

NOTE 2: It is assumed that the PMID does not change during one connection (e.g. from an arbitrary PMID to a PMID derived from the assigned individual TPUI (see clause 11.7.2)).

The first task of the calling side's MBC is to invoke the creation of a new MBC at the called side. To allow the necessary radio transmissions at least one bearer controlled by a TBC shall exist. For setting up new bearers the MBC chooses one of the bearer setup procedures. The choice depends on the requested service (see clauses 10.2.4.2 and 10.2.4.3).

Higher layer control during connection setup:

At the calling side the MAC may enable transmissions of higher layer control even in the first transmission. After receiving the MAC_CON-req primitive the MAC may ask immediately for higher layer control segments with a MAC_CO_DTR-ind primitive (see clause 8.4.3).

Called side:

On the called side a new TBC is created by receiving a "bearer_request" message including both a calling address and its own address (FMID and PMID) on the scanned physical channel. The message type also contains the information if the new bearer belongs to a basic or an advanced connection.

The TBC has then to receive all necessary parameters to identify an MBC. The MBC is fully identified after:

- a) receiving with the "bearer_request" message either an access request or a handover request, including the calling address (FMID or PMID) and defining the connection type (advanced or basic); and
- b) for advanced connections only, receiving an ECN; and
- c) for basic connections and only in case of a handover request, an indication if bearer or connection handover is wanted.

NOTE 3: The parameters are not always known after the first received message, e.g. for setup procedures using the advanced connection control M_T message set, the conditions are fulfilled after receiving two messages, the "bearer_request" message and the "attributes_request" message (see clause 10.5.1.2.1).

The TBC issues PMID, ARI and for an advanced connection also the ECN to the LLME and indicates the purpose of the wanted connection (bearer/connection handover or new connection).

NOTE 4: For an FT initiated bearer setup the calling address is the FMID. But the PT has to be locked to the calling RFP and, therefore, the PT knows the FT's ARI.

The LLME can now decide:

- a) to release the TBC;
- b) to connect the TBC to an existing MBC; or
- c) to create a new MBC for connecting the TBC.

If a new MBC is needed the LLME requests the MAC to create a new MBC and assigns a MCEI to this MBC. The creation of a new MBC is reported to the DLC by issuing a MAC_CON-ind primitive after the first successful bearer setup. This primitive informs the DLC if a basic or an advanced connection is set-up, and describes the wanted service type.

NOTE 5: The wanted service may be of type "unknown" at this moment.

During connection setup there is no information exchanged that indicates if a connection (i.e. its ECN) belongs to a Broadband data link. The receiving side LLME shall make its judgement if a connection (i.e. its ECN) belongs to a Broadband data link based on information from the result of the NWK layer Broadband data link ECNs agreement and allocation procedure.

Higher layer control during connection setup:

The called side may enable transmission of higher layer control after issuing the MAC_CON-ind primitive. The MAC has to ask for this higher layer control with a MAC_CO_DTR-ind primitive (see clause 8.4.3).

10.2.4.2 Establishment of a single bearer duplex connection of a known service type

This procedure is applied for all basic connections and for some advanced connections. Advanced connections are established with this procedure provided that:

- a) the MAC_CON-req primitive at the initiating side contained the full MAC layer service description; and
- b) the connection is a single bearer connection.

For a single bearer connection the duplex bearer setup is initiated by:

- a) the PT, for basic and normal connection setup;
- b) the FT, for fast connection setup.

With the creation of the MBC on the initiating side a connection setup timer (T200, see annex A) is started. A successful connection setup shall be completed before this timer expires. Otherwise the connection setup fails.

The MBC of the initiating side shall have knowledge of at least one available physical channel. The MBC shall also know the address (FMID or PMID) of the called part. The MBC creates a TBC and issues the called address (FMID/PMID) and the physical channel description to the new TBC. The MBC also indicates if the wanted bearer is used for bearer handover, connection handover or for a new MAC connection and which single bearer setup procedure has to be used. For advanced single bearer connections the logical bearer number of the only bearer shall be set to 15 (= "1111"). The MBC issues the LBN and the ECN to the TBC.

To establish the bearer the TBC uses one of the following procedures:

- a) the basic bearer setup procedure (see clause 10.5.1.1) for a basic connection setup;
- b) the PT initiated A-field advanced single bearer setup procedure (see clause 10.5.1.2.1) or the PT initiated B-field advanced single bearer setup procedure (see clause 10.5.1.3.1) for a normal connection setup;
- c) the FT initiated B-field advanced single bearer setup (see clause 10.5.1.3.2) for fast connection setup.

At the end of a setup procedure a TBC will report to the MBC either:

- "Bearer_established" or "bearer_setup_failed", indicating the reason.

NOTE 1: At the destination side these messages only occur if a bearer setup attempt was detected and a new MBC was created.

If a bearer setup attempt failed the TBC is released (see bearer setup procedures). The calling MBC can reattempt with the same procedure up to N200 (see annex A) times, subject to using a new available channel each time and/or accessing a new RFP (see clause 11.4.2). Each reattempt is reported to the DLC with a MAC_RES_DLC-ind primitive.

NOTE 2: This reporting of reattempts is necessary to support overlapped setup, whereby setup of the higher layers occurs at the same time as setup of the MAC layer.

Explanation: The MAC forgets acknowledged higher layer data and so this data cannot be repeated in a MAC bearer setup reattempt. The primitive, therefore, tells the higher layers that a new connection setup was started automatically. Higher layers shall restart their overlapped procedures, or shall release the MAC setup with a MAC_DIS-req primitive.

If the setup attempt fails N200 + 1 times or the connection setup time-out (T200) expires, the initiating MAC reports "setup_failure" to its DLC, using a MAC_DIS-ind primitive with the reason and releases the MBC. This event is also reported to the LLME.

At the called side it is not always possible to recognize how often setup attempts fail. Here the MBC is always released when "bearer_setup_failed" was recognized (see single bearer setup procedures) or by a time-out (e.g. T200 or T201). The connection setup timer (T200) for a new MBC shall be started at creation of the MBC. Release of an MBC at the called side is always reported to the LLME, and to its DLC with a MAC_DIS-ind primitive provided that a MAC_CON-ind primitive was issued before.

NOTE 3: This condition may occur if a bearer setup was successful at the called side but failed at the calling side. Here the calling side may reattempt to setup a bearer.

An MBC assumes that a bearer setup was successful when the TBC reported "bearer_established".

When the TBC at the called side reports "bearer_established" the MBC knows all necessary MAC parameters for the wanted service. If the MAC does not support the wanted service it will proceed with a connection release procedure and should indicate the reason (see clause 10.4).

If the MAC supports the service the connection setup for a single bearer connection is completed. Immediately after the TBC reported "bearer_established" the MAC reports "connection_established" plus service parameters with a MAC_CON-ind primitive at the called side or with a MAC_CON-cfm primitive at the initiating side to the DLC. All following transmissions may contain valid I channel data and the MAC uses the appropriate multiplex for the wanted service.

10.2.4.3 Establishment of multi-bearer connections and connections needing service negotiation

Overview:

The following service negotiation procedures shall be used to establish all asymmetric connections, and shall also be used for symmetric multi-bearer connections.

The procedure shall also be applied for connections with service type "unknown".

Channel list messages shall be used for the establishment of asymmetric connections as defined in clause 10.5.1.4. Channel list messages should be used for all multibearer connection establishment.

During a multi-bearer connection establishment, the first pilot (duplex) bearer within one connection shall be set-up by the initiating side (see clauses 10.2.2 and 10.2.3). Either of the two MBCs may be the master for all subsequent bearer establishment in the sense that this MBC initiates all of the remaining bearer setups.

The multi-bearer connection establishment procedure starts with the setting up of one duplex bearer, the "pilot channel". This allows the service type to become known, (if it was unknown), and initial channel list messages to be exchanged.

NOTE 1: Channel list messages and procedures are described in clause 10.5.2.

The pilot (duplex) bearer setup is initiated by:

- the PT, for normal connection setup;

- the FT, for fast connection setup.

Procedure description:

The receipt of a MAC_CON-req primitive causes the creation of the MBC on the initiating side and the starting of a connection setup timer (T200). A successful connection setup shall be completed before this timer expires. Otherwise the connection setup fails and any bearers that have been set-up are released.

The MBC of the initiating side shall have knowledge of at least one available physical channel. The MBC shall also know the address (FMID or PMID) of the called part. The MBC creates a TBC and issues the called address (FMID/PMID) and the physical channel description to the new TBC. The MBC also indicates if the wanted pilot bearer is used for connection handover or for a new connection. For the pilot bearer the MBC sets the logical bearer number to 15 (= "1111") and issues the LBN and the ECN to the TBC.

To establish the bearer the TBC uses one of the following procedures:

- the PT initiated A-field advanced single bearer setup procedure (see clause 10.5.1.2.1) or the PT initiated B-field advanced single bearer setup procedure (see clause 10.5.1.3.1) for a normal connection setup;
- the FT initiated B-field advanced single bearer setup (see clause 10.5.1.3.2) for fast connection setup.

At the end of a setup procedure a TBC will report to the MBC either:

- "bearer_established"; or
- "bearer_setup_failed", indicating the reason.

NOTE 2: At the destination side these messages only occur if a bearer setup attempt was detected and a new MBC was created.

If a bearer setup attempt failed the TBC is released (see bearer setup procedures) and the calling MBC can reattempt with the same procedure up to N200 (see annex A) times, subject to using a new available channel each time and/or accessing a new RFP (see clause 11.4.2). Each reattempt is reported to the DLC with a MAC_RES_DLC-ind primitive.

NOTE 3: This reporting of reattempts is necessary to support overlapped setup, whereby setup of the higher layers occurs at the same time as setup of the MAC layer.

Explanation: The MAC forgets acknowledged higher layer data and so this data cannot be repeated in a MAC bearer setup reattempt. The primitive, therefore, tells the higher layers that a new connection setup was started automatically. Higher layers shall restart their overlapped procedures, or shall release the MAC setup with a MAC_DIS-req primitive.

If the setup attempt fails N200 + 1 times or the connection setup time-out expires (T200) the initiating MAC reports "setup_failure" to the DLC, using a MAC_DIS-ind primitive with the reason set and releases the MBC. This event is also reported to the LLME.

At the called side it is not always possible to recognize how often setup attempts fail. Here the MBC is always released when "bearer_setup_failed" was recognized (see single bearer setup procedures) or by a time-out (e.g. T200 or T201). The setup timer (T200) for a new MBC shall be started at the creation of the MBC. A release of an MBC is always reported to the LLME, and to the DLC with a MAC_DIS-ind primitive provided that a MAC_CON-ind primitive was issued before.

An MBC assumes that a bearer setup was successful when the TBC reported "bearer_established".

When the TBC at the called side reports "bearer_established" the called MBC may know all the necessary MAC parameters for the wanted service. If the service is defined and the called MAC does not support this service it will proceed with a connection release procedure and should indicate the reason (see clause 10.4). Otherwise the MBC issues a MAC_CON-ind primitive to the DLC.

The MBC on the initiating side issues a MAC_CON-cfm primitive to the DLC after the TBC reported "bearer_established".

If the service is not fully defined, e.g. the service type is "unknown" or the number of bearers is undefined, the connection is in a pending state until the DLC on either side issues a MAC_MOD-req primitive that shall contain all necessary parameters.

NOTE 4: For PT initiated calls the MAC_MOD-req primitive may be issued at the same time as the MAC_CON-req primitive.

NOTE 5: A MAC_MOD-req primitive is needed for all multibearer connections.

The MBC at the side where the MAC_MOD-req primitive was issued shall release the connection when the wanted service is not able to be supported. Otherwise the MBC sends repeatedly the appropriate attributes and/or bandwidth request messages, until these messages are confirmed or a connection release is recognized. If both messages are needed, the bandwidth request message shall not precede the attribute request message.

When negotiating the bandwidth the requesting side shall propose the wanted bandwidth. The bandwidth confirm message, however, may contain the same minimum and target number of bearers or a reduced number of bearers. The negotiated bandwidth is given by the numbers in the confirm message. If the bandwidths in the request and confirm message are different the MBC at the initiating side shall issue a MAC_BW-ind primitive to the DLC. When the offered bandwidth is sufficient for the service the DLC shall reply with a MAC_BW-res primitive, otherwise with MAC_DIS-req primitive. The latter case shall cause a connection release.

MAC_MOD-ind and MAC_MOD-cfm shall not be issued until the connection is fully established. To establish the other bearers of the connection (additional duplex or double simplex bearers) the access_request message shall always be used, even in case the pilot bearer has been setup for connection handover.

Now the two MBC functions have the same, complete, knowledge of the connection that is required. Further progress depends upon the service type:

- symmetric connection;
- asymmetric uplink connection; or
- asymmetric downlink connection.

Additional bearers for ciphered connections shall be established in clear and afterwards they shall be switched to the current encryption state.

10.2.4.3.1 Symmetric connection

A symmetric connection is one that offers a symmetric I channel service to the DLC. The eventual bandwidth and service type for the direction PP to FP and FP to PP are identical. A symmetric connection shall only use duplex bearers.

If the connection is a single bearer connection (previously of type "unknown"), this is now established and MAC_MOD-ind and MAC_MOD-cfm primitives are issued.

Otherwise this is a multibearer connection, and all following bearer set-ups shall be PT initiated. The PT shall "add" duplex bearers using the A-Field advanced or B-Field single bearer setup procedures (see clauses 10.5.1.2.1 and 10.5.1.3.1). The channel list procedures described in clause 10.5.2 should be used to decrease the connection establishment time by negotiating changes to the receiver scanning patterns at the receiving side.

10.2.4.3.2 Asymmetric uplink connection

An asymmetric uplink connection is one that offers an asymmetric I channel service to the DLC. It shall use a mixture of double simplex bearers in the direction PP to FP and duplex bearers.

For all subsequent double simplex bearer setups the PT is the T-side. The double simplex setup procedure is described in clause 10.5.1.4.

The number of duplex bearers shall be determined by the MBC in the PT, and at least one duplex bearer shall be maintained at all times. The PT may add duplex bearers by using the procedures defined in clauses 10.5.1.2.1 or 10.5.1.3.1. For setting up further duplex bearers the channel list procedures (see clause 10.5.2) shall be used in order to decrease the connection establishment time.

10.2.4.3.3 Asymmetric downlink connection

An asymmetric downlink connection is one that offers an asymmetric I channel service to the DLC. It shall use a mixture of double simplex bearers in the direction FP to PP and duplex bearers.

For all subsequent double simplex bearer setups the FT is the T-side. The double simplex setup procedure is described in clause 10.5.1.4.

The number of duplex bearers shall be determined by the MBC in the FT, and at least one duplex bearer shall be maintained at all times. The FT may add duplex bearers by using the procedures defined in clauses 10.5.1.2.2 or 10.5.1.3.2. For setting up further duplex bearers the channel list procedures (see clause 10.5.2) shall be used in order to decrease the connection establishment time.

10.2.4.3.4 Connection established

When the number of established bearers equals the "minimum" parameter the MBC entities shall issue the appropriate MAC_MOD primitive (ind or cfm) to report "connection_established". The MBCs shall keep attempting to obtain the "target" number of bearers until the connection setup timer (T200) expires, and may try to obtain this number of bearers afterwards.

If the connection set-up timer expires at either side before the "minimum" number of bearers is established, a MAC_DIS-ind primitive is issued containing "connection_establishment_failure" and all established bearers are released. The release of the bearers shall cause the other side to issue a MAC_DIS-ind primitive.

All transmissions following the MAC_MOD-ind or MAC_MOD-cfm primitive respectively may contain valid I channel data and the MAC shall use the appropriate multiplex for the wanted service.

The number of bearers established shall not exceed the agreed target number.

NOTE: The receiving side should send a Release message (with release reason "Target number exceeded") in response to an access_request for a new bearer which would exceed the agreed target number.

10.2.5 Expedited connections

Expedited connections are defined as the connections able to use the expedited messages of the advanced connection control part 2 set and their associate procedures for bearer setup and release.

From MAC C/O perspective, expedited connections are advanced connections. Expedited connections may also use the other advanced connection control messages.

Expedited messages are only used for resume (bearer setup of existing MAC connections) or suspend (bearer release without clearing the connection at MBC level).

10.3 C/O connection modification

10.3.1 Advanced connection: bandwidth modification

The DLC on either side may initiate a connection modification of an advanced connection by issuing a MAC_MOD-req primitive.

Bandwidth modifications to existing connections allow the bandwidth to be changed, i.e. the number of required bearers. The transmission direction of double simplex bearers may be switched by using the fast release procedure (see clause 10.7.2.3). Switching a bearer from duplex to double simplex and vice versa is prohibited.

NOTE 1: A bandwidth change may switch a single bearer connection to a multibearer connection and vice versa.

NOTE 2: A bandwidth change may switch an asymmetric connection to a symmetric connection and vice versa or may change the direction of an asymmetric connection.

NOTE 3: Some bandwidth change requests may cause ambiguous situations of the MAC I channel data flow, e.g.:

- the wanted minimum number of simplex bearers in one direction is above the actual number of established bearers, and, therefore, the MAC cannot provide the new service instantaneously;
- sequencing of data segments in I_N-normal_delay and I_p-error_detection services might fail during the establishment of new bearers.

NOTE 4: In multibearer connections the sequencing of I channel data segments for $I_{N_normal_delay}$ service can only be guaranteed by the MAC layer if the minimum number of needed bearers equals the target number of bearers. Adding or releasing bearers during a call may cause ambiguous situations (see clauses 8.4.3 and 10.8.3.2). This ambiguity does not happen if the DLC provides sequence numbers.

Whenever the bandwidth change might cause ambiguity for the data service it is assumed that the side which invokes the connection modification has already negotiated the modification at a higher layer.

The MBC at the initiating side sends the appropriate bandwidth request message (A-field or B-field) in up to five successive allowed frames until a bandwidth confirm message is received or a connection release is recognized. The bandwidth request and confirm messages shall be exchanged on any duplex bearer of the. If after five consecutive bandwidth request messages being sent no bandwidth confirm message is detected, the MBC at the initiating side shall react as if a bandwidth confirm message to the current band was received.

The bandwidth confirm message may contain the same minimum and target number of bearers or reduced number of bearers. In some DPRS use cases (see EN 301 649 [9]), the target number of bearers could be larger. The negotiated bandwidth is given by the numbers in the confirm message. If the bandwidths in the request and confirm message are different the MBC at the initiating side shall issue a MAC_BW-ind primitive to the DLC. When the offered bandwidth is sufficient for the service, the DLC shall reply with a MAC_BW-res primitive, otherwise with a MAC_DIS-req primitive.

In DPRS (see EN 301 649 [9]), the MAC bandwidth control primitives are handled by the Management Entity, and the DLC does not need to deal with them. The DLC sees a variable bandwidth link provided by the MAC layer and delivers packets (PDUs) at a variable rate. The bandwidth of the link could be even zero (suspend state) and the DLC shall not disconnect the link in this case.

A bandwidth request from the far side should be answered before a bandwidth request from the near side may be sent. A bandwidth confirm message should be regarded as acknowledged when no further bandwidth request message is received in the next suitable frame. A bandwidth request or a bandwidth confirm message shall be taken into account by the receiving side only if error free, that means message type decoded and the corresponding CRC passed.

EXAMPLE:

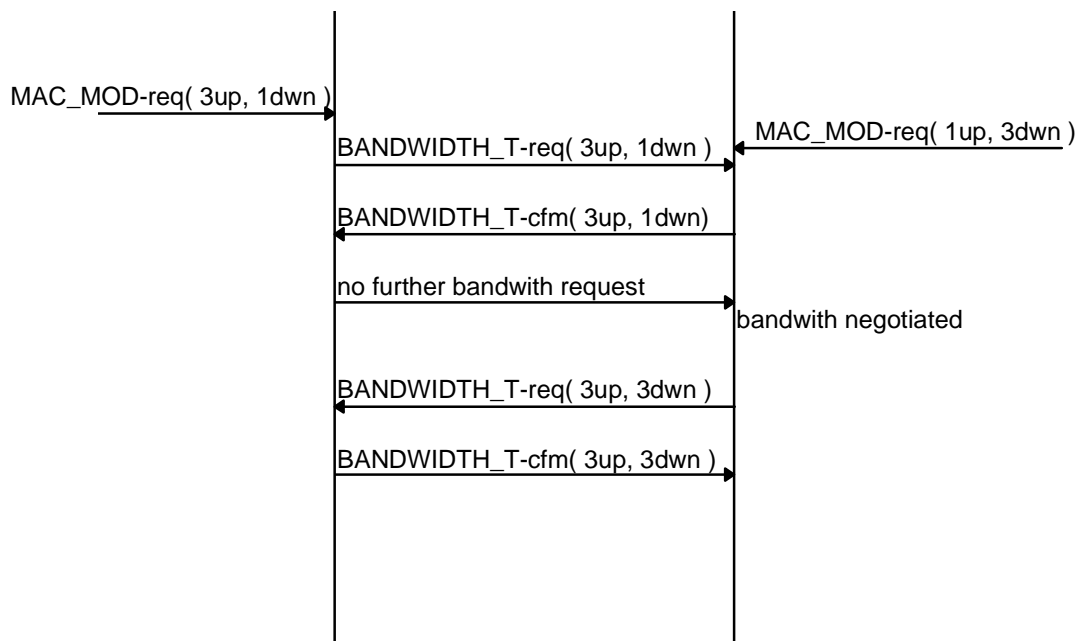

Figure 10.1: Bandwidth Modification example

In case of a request to decrease the bandwidth the receiving side may reply with the actual bandwidth.

After this negotiation the agreed bandwidth for both directions may be the same (e.g. the far end does not allow a change and the bandwidth is still sufficient). For this case the procedure ends.

To modify the connection according to the negotiated new bandwidth one of the MBC is the master in the sense that only this MBC may initiate new bearer setups. If the modified connection is symmetric or an asymmetric uplink, the PT is the master. For asymmetric downlink connections the FT is the master.

The slave shall release all existing double simplex bearers in the direction slave to master. Independently for each double simplex bearer, the slave shall choose either the unacknowledged release procedure or the fast release procedure. The fast release procedure allows the immediate setup of a new double simplex bearer on the same physical channels but in the reverse direction.

First the master shall release bearers, such that in neither direction the established number of bearers remains above the target number.

If in both directions the number of surviving bearers is equal to or greater than the minimum number of bearers, both MBCs, issue a MAC_MOD primitive (-ind or -cfm) to indicate the new available bandwidth. The masters MBC may still try to setup the target number of bearers.

If in either direction the number of surviving bearers is less than the minimum required bearers the connection modification timer (T211) is started and the master tries to setup the required number of bearers using the procedures in clause 10.2.4.3.1 through clause 10.2.4.3.3. If the minimum number of bearers is not established before the connection modification timer expires, the MBCs send a MAC_DIS-ind primitive to the DLC. As a consequence the connection is released.

The modification is successfully completed when the minimum number of bearers is established before the modification timeout expires. This event is reported to the DLC on both sides with a MAC_MOD primitive (-ind or -cfm). The master's MBC may still try to achieve the target number of bearers even after the connection modification timer expires (T211).

The number of bearers established shall not exceed the agreed target number.

NOTE 5: The receiving side should send a Release message (with release reason "Target number exceeded") in response to an access_request for a new bearer which would exceed the agreed target number.

10.3.1.1 Suspend and resume

The suspend and resume procedures are particular cases of Bandwidth Modification. In the suspend procedure, the negotiated bandwidth value is zero. As result of this modification the "logical connection" will pass to "suspended state" and all physical connection associated to it will be release.

The connection resumption is the procedure to leave the suspended state by setting up a pilot duplex bearer, followed by bandwidth modification when necessary. The "logical connection" will pass to "active state" as result of the connection resumption procedure. The resumption procedure can be initiated either by FP or PP. The FP could use the MAC-resume paging in order to initiate the connection resume procedure.

In profiles that use only single bearer connections, the "Bandwidth" message is, in general not used and the suspend state is reached by releasing the bearer without an explicit higher layer (NWK) release operation. Conversely, the resume is implemented just by setting a bearer of an already existing connection in suspended state (identified by an existing ECN number).

NOTE: Examples of profiles that use such mechanism are NG-DECT Part 4 (TS 102 527-4 [i.11]) and DECT ULE (TS 102 939-1 [i.10]).

10.3.1.1.1 Expedited suspend and resume

The "expedited" messages of the advanced control part 2 set (see clause 7.2.5.12) and their associated procedures (see clauses 10.5.1.8 and 10.7.3) are used for optimized bearer setup (resume) or bearer release (suspend) in packet mode connections. Such procedures may be referred as "expedited suspend" and "expedited resume".

10.3.1.2 MAC resume paging

MAC resume paging is the procedure which may be used by the FP MBC to resume a suspended MAC connection without using fast connection setup procedures.

The FP MBC may, if the PP is known not to support fast setup or if this procedure has previously failed, issue a resume page message using the MAC page procedure (see clause 9.1.3.1) and start timer an implementation dependent timer. If the PP supports fast paging and is known to be in high duty cycle Idle_Locked mode, fast paging shall be used. The PP MBC shall reply the resume page message only if a suspended connection with the indicated PMID and ECN exists by resuming the connection, i.e. initiating a set-up of the physical connection followed by a bandwidth modification. The FP MBC shall stop the timer if a successful resume is made within the duration of the timer. If the timer expires, the procedure shall be considered failed and this shall be indicated to the higher layers.

The value of the timer is up to the implementor.

10.3.1.3 ULE resume paging

For Ultra Low Energy (ULE) PPs, a dedicated paging channel inside the B-field of the dummy bearer(s) is used for triggering the resume process (FT initiated indirect setup). This paging channel operates also at MAC layer and has its own operation rules (refer to TS 102 939-1 [i.10] for details).

10.3.2 Advanced connection: service type or slot type modification

The procedures from this clause can be used to change the service type and or the slot type of an existing advanced connection. The following procedures are given in detail: service type modification, slot type modification (i.e. full to double slot and double to full slot) and ECN number modification. The slot type change procedure is similar for other slot type modifications which are not explicitly described, e.g. full to long slot, long slot to full slot, long to double slot, double to long slot, etc.

The modification of a connection service type and/or slot type starts with the initiation process, the DLC in either the PT or the FT, issuing a MAC_MOD-req primitive to its MAC.

This primitive includes the following parameters:

- MCEI: used to identify the connection at which the request applies;
- ECN: used to identify the connection at which the request applies;
- switching type: used to identify the requested switching;
- slot type: used to identify the requested slot type;
- service type: used to identify the requested service type.

The relevant MAC messages shall be exchanged on a duplex bearer of the connection.

10.3.2.1 Procedure for service type modification

The initiating side, which is the one that has received the MAC_MOD-req primitive, starts to transmit in the next allowed frame the attributes_T_request (advanced connection control set). This is repeated in the five successive allowed frames or until the initiating side receives the attributes_T_confirm (advanced connection control set).

The initiating side shall acknowledge the receipt of the attributes_T_confirm message by the transmission of another message in the next TDMA frame. For this procedure the other message means any other message than a MAC release message or a repeated attributes_T_request message in a frame suitable for retransmission of the attributes_T_request message.

If the attributes_T_confirm is not received the initiating side shall release the connection and the DLC layer is informed using the MAC_DIS-ind primitive.

After receiving the attributes_T_request message from the initiating side, the receiving side shall start the T218 timer within which the switching procedure (attributes scenario) shall be completed and it shall transmit the attributes_T_confirm message. Every time the attributes_T_request is received from the initiating side (repeated) the attributes_T_confirm shall be retransmitted to the initiating side.

If the timer expires the receiving side shall release the connection and the DLC layer is informed using the MAC_DIS-ind primitive.

After the attributes scenario has been performed successfully, the MAC at both sides sends to the DLC the MAC_MOD primitive, confirm or indication indicating that the old connection has changed its service profile as requested and that the procedure has been successfully completed.

For the timing, when to switch to the new service type, the following rules shall apply.

The attributes_T_confirm message is the first burst sent by the responding side containing data of the new service type. All following bursts sent by the responding side shall contain data of the new service type. The initiating side may assume received data to be of the new service type starting from that burst containing the attributes_T_confirm message. From that TDMA frame where the first attributes_T_confirm message is expected up to the first error free received attributes_T_confirm message, received user data should be ignored due to the uncertain service type used.

The other message is the first burst sent by the initiating side containing data of new service type. All following bursts sent by the initiating side shall contain data of the new service type. The responding side may assume received data to be of the new service type starting from that burst containing the other message. From that TDMA frame where the first other message is expected up to the first error free received other message, received user data should be ignored due to the uncertain service type used.

10.3.2.2 Procedures for slot type modification

10.3.2.2.1 Procedure for slot type modification full to double

NOTE 1: This procedure handles the case when the slot is getting longer, e.g. full to long, full to double, long to double, etc.

FT initiated:

- The initiating side (i.e. the FT), starts to transmit in the next allowed frame the attributes_T_request (advanced connection control set). This is repeated in the five successive allowed frames or until the attributes_T_confirm (advanced connection control set) is received.
- The initiating side shall acknowledge the receipt of the attributes_T_confirm message by the transmission of another message in the next TDMA frame and after that it shall start the handover procedure. The receiving side (PT) shall start the handover procedure after receiving the other message (see clause 10.6.2: Handover is always PT initiated). The initiating side shall start the timer T218 within which the handover scenario (e.g. establishing a new "double slot" bearer and releasing the current "full slot" bearer) shall be completed.
- If the attributes_T_confirm is not received the initiating side shall release the connection and the DLC layer is informed using the MAC_DIS-ind primitive.
- The receiving side after receiving the attributes_T_request message from the initiating side, shall start the T218 timer within which the switching procedure (attributes scenario - converting the existing "full slot" bearer into a "double slot" bearer, and handover scenario (e.g. establishing a new "double slot" bearer and releasing the current "full slot" bearer) shall be completed and it shall transmit the attributes_T_confirm message. Every time the attributes_T_request is received from the initiating side (repeated) the attributes_T_confirm shall be retransmitted to the initiating side.
- If the handover procedure fails (which can also be indicated by timer expiry), the connection shall remain on the original bearer. The MAC at both sides sends to the DLC the MAC_MOD primitive, confirmation or indication indicating the failure of the procedure.
- If the handover procedure has been performed successfully, the MAC at both sides sends to the DLC the MAC_MOD primitive, confirm or indication indicating that the old connection has changed its slot type as requested and that the procedure has been successfully completed.

PT initiated:

- For connection modification PT initiated, the attributes exchange scenario shall not apply and only the handover procedure shall be performed: the PT after receiving the MAC_MOD-req primitive starts the handover scenario directly. The initiating side (PT) shall start the timer T218 within which the handover scenario (e.g. establishing a new "double slot" bearer and releasing the current "full slot" bearer) shall be completed.

- If the handover procedure fails, the connection shall remain on the original bearer. The MAC at the initiating side sends to the DLC the MAC_MOD primitive, confirmation indicating the failure of the procedure.
- If the handover procedure has been performed successfully, the MAC at both sides sends to the DLC the MAC_MOD primitive, confirm or indication indicating that the old connection has changed its slot type as requested and that the procedure has been successfully completed.

NOTE 2: For the handover procedure either the bearer or the connection handover can be used.

10.3.2.2.2 Procedure for slot type modification double to full

NOTE: This procedure handles the case when the slot is getting shorter, e.g. long to full, double to full, double to long, etc.

The procedure is the same, whether it is PT-initiated or FT-initiated:

- The initiating side, which is the one that has received the MAC_MOD-req primitive, starts to transmit in the next allowed frame the attributes_T_request (advanced connection control set). This is repeated in the five successive allowed frames or until the initiating side receives the attributes_T_confirm (advanced connection control set): the slot is still double.
- The initiating side shall acknowledge the receipt of the attributes_T_confirm message by the transmission of another message in the next TDMA frame. The MAC layer then switches from double to full slot releasing the second part of the double slot and sends to its DLC the MAC_MOD-cfm primitive with the "result" parameter set to accept and the "slot type" parameter set to full.
- If the attributes_T_confirm is not received the initiating side shall release the connection and the DLC layer is informed using the MAC_DIS-ind primitive.
- After receiving the attributes_T_request message from the initiating side, the receiving side shall transmit the attributes_T_confirm message: the slot type is still double. Every time the attributes_T_request is received from the initiating side (repeated) the attributes_T_confirm shall be retransmitted to the initiating side.
- After receiving the other message the receiving side switches to a full slot releasing the second part of the double slot and sends to the DLC the MAC_MOD-ind with the "result" parameter sets to accept and the "slot type" parameter sets to full.
- At both DLC layers, the receipt of this primitive (MAC_MOD-cfm or ind) acts as a synchronization signal for the U-Plane switching procedure. Then, the DLC in both initiating and receiving side shall switch correctly the C-Plane link and U-plane service and release the old link. The DLC at both sides indicates to the LLME that the procedure has been correctly done.

10.3.2.2.3 Procedures for slot type modification to/from long

The slot type modification from full to long with shall be done analogous to the modification from full to double.

The slot type modification from double to long with shall be done analogous to the modification from double to full.

The slot type modification from long with to double shall be done analogous to the modification from full to double.

The slot type modification from long with to full shall be done analogous to the modification from double to full.

10.3.2.2.4 Procedure for slot type modification in multibearer connections

In multibearer connections, in order to perform a slot type modification the following procedure shall be used:

- The multibearer connection shall be reduced to single bearer connection executing the bandwidth modification procedure (clause 10.3.1) with target number of bearer equal to 1.
- Once the bandwidth modification has been completed, the slot type modification procedure shall be performed according to clauses 10.3.2.2.1, 10.3.2.2.2 or 10.3.2.2.3.
- After completion of the slot type change procedure, the bandwidth of the connection shall be expanded to the required level using the bandwidth modification procedure (clause 10.3.1).

NOTE: The bandwidth modification procedure to single bearer should be completely terminated (confirm message received) before initiating the slot change. It is not allowed to start the slot type modification procedure in a connection with negotiated target number of bearers larger than 1, even if momentarily there is only one bearer on the air.

10.3.2.3 Procedure for ECN number modification in an advanced connection

It is possible to change the ECN number in an advanced connection. This procedure could be necessary due to the special behaviour of the ECN=0 value (see clause 10.3.3) or ECN = 7 if expedited operations are supported (see clause 5.6.1.2.2). The target ECN value is chosen by the initiating side and can be any unused value fulfilling the rules described in prerequisites.

Prerequisites

- There should not exist other advanced connection between the same FT-PT pair with the target ECN number.
- If the target ECN number is zero, THEN: there should not exist a basic connection between the same FT-PT pair.

Procedure

The same procedure as the one used for service type modification shall apply with the following exceptions:

- The initiating side shall send the `attributes_T_request` message with the target ECN number in one frame.
- The initiating side will repeat the `attributes_T_request` message with the target ECN number in the next four allowed frames, or until it receives an `attributes_T_confirm` message with the target ECN.
- The procedure is considered completed when the initiating side receives an `attributes_T_confirm` message with the target ECN.
- If the receiving side is, by any reason, not able to accept the change, it will reply with an `attributes_T_confirm` message with the existing ECN.
- No other attributes change shall be requested at the same time of the ECN number change.

NOTE: If the ECN is set to zero and the connection attributes are "`IN_minimum_delay`", `full_slot`, no `CF` and `LBN=15`, then this is the advanced to basic connection type modification procedure that will be performed as described in clause 10.3.3.2.

10.3.3 Connection type modification

These procedures can be used to change connection type (basic to advanced or advanced to basic). During the same procedure the service type and/or slot type of an existing connection can also be changed.

In this clause the following three procedures are given in detail: the basic to advanced connection type modification, the advanced to basic connection type modification and the basic to advanced connection type modification plus full to double slot type modification. The procedure including slot type modification is similar for other slot type modifications which are not explicitly described, e.g. full to long slot, etc.

A connection type modification starts with the initiation process, the DLC in either the PT or the FT, issuing a `MAC_MOD-req` primitive to its MAC.

This primitive includes the following parameters:

- `MCEI`: used to identify the basic/advanced connection at which the request applies;
- `ECN`: the new value that will be assigned to the basic connection changed in an advanced one;
- `switching type`: used to identify the requested switching (i.e. basic to advanced);
- `slot type`: used to identify the requested slot type;
- `service type`: used to identify the requested service type.

The relevant MAC messages shall be exchanged on a duplex bearer of the connection.

10.3.3.1 Procedure for connection type modification basic to advanced

10.3.3.1.1 General procedure

The initiating side, that is the one that has received the MAC_MOD-req primitive, starts to transmit in the next allowed frame the attributes_T_request (basic connection control set). This is repeated in five successive allowed frames or until the initiating side receives the attributes_T_confirm (basic connection control set).

The initiating side shall acknowledge the receipt of the attributes_T_confirm message by the transmission of another message in the next TDMA frame.

If the attributes_T_confirm is not received the initiating side shall release the connection and the DLC layer is informed using the MAC_DIS-ind primitive.

After receiving the attributes_T_request message from the initiating side, the receiving side shall start the T218 timer within which the switching procedure (attributes scenario) shall be completed and it shall transmit the attributes_T_confirm message. Every time the attributes_T_request is received from the initiating side (repeated) the attributes_T_confirm shall be retransmitted to the initiating side. If the timer expires the receiving side shall release the connection and the DLC layer is informed using the MAC_DIS-ind primitive.

After the attributes scenario has been performed successfully, the MAC at both sides sends to the DLC the MAC_MOD primitive, confirm or indication indicating that the old connection identified by the MCEI has changed its connection type as requested and is now identified by the pair old MCEI and new ECN and that the procedure has been successfully completed.

10.3.3.1.2 Procedure for connection type modification basic to advanced plus slot type modification full to double

- The initiating side, which is the one that has received the MAC_MOD-req primitive, starts to transmit in the next allowed frame the attributes_T_request (basic connection control set). This is repeated in five successive allowed frames or until the initiating side receives the attributes_T_confirm (basic connection control set).
- The initiating side shall acknowledge the receipt of the attributes_T_confirm message by the transmission of another message in the next TDMA frame and after that it shall start the handover procedure, if the procedure is PT initiated. If the procedure is FT initiated, the PT shall start the handover procedure after receiving the other message (see clause 10.6.2: Handover is always PT initiated). The initiating side shall start the timer T218 within which the handover scenario (e.g. establishing a new "double slot" bearer and releasing the current "full slot" bearer) shall be completed.
- If the attributes_T_confirm is not received than the initiating side shall release the connection and the DLC layer is informed using the MAC_DIS-ind primitive.
- After receiving the attributes_T_request message from the initiating side, the receiving side shall start the T218 timer within which the switching procedure (attributes scenario and handover scenario (e.g. establishing a new "double slot" bearer and releasing the current "full slot" bearer) shall be completed and it shall transmit the attributes_T_confirm message. Every time the attributes_T_request is received from the initiating side (repeated) the attributes_T_confirm shall be retransmitted to the initiating side.
- If the handover procedure fails (which can also be indicated by timer expiry), the connection shall remain on the original bearer. The MAC at both sides sends to the DLC the MAC_MOD primitive, confirmation or indication indicating the failure of the procedure.
- If the handover procedure has been performed successfully, the MAC at both sides sends to the DLC the MAC_MOD primitive, confirm or indication indicating that the old connection identified by the MCEI has changed its service profile as requested and is now identified by the pair old MCEI and new ECN and that the procedure has been successfully completed. The DLC can now perform the switching of the U-plane channel. The DLC at both sides indicates to the LLME that the procedure has been correctly done.

NOTE: For the handover procedure either the bearer or the connection handover can be used.

10.3.3.1.3 Procedure for connection type modification basic to advanced plus slot type modification full to long

The connection type modification basic to advanced plus slot type modification full to long is done analogous to the modification basic to advanced plus slot type modification full to double.

10.3.3.2 Procedure for connection type modification advanced to basic

The same procedure as the one used for connection type modification basic to advanced shall apply with the following exceptions:

Prerequisites

- The connection shall be an advanced connection and the slot type shall be full slot:
 - If the slot type is not full slot, then a slot type modification (using the procedures described in clause 10.3.2.2) should be performed before the modification advanced to basic.
- There should not be any existing basic connection between the FT/PT pair.
- There should not be other Advanced connection with ECN=0 between the FT/PT pair:
 - If there is other Advanced connection with ECN=0 between the FT/PT pair, then the ECN number of this connection shall be modified (see clause 10.3.2.3) before starting the modification advanced to basic procedure.

Procedure

The same procedure as the one used for connection type modification basic to advanced shall apply with the following exceptions:

- The attributes_T_request/confirm messages shall belong to the advanced connection control set.
- The attributes_T_request/confirm message shall indicate the parameters that can be used with a basic connection: full-slot, I_N_minimum_delay, and no C_F.
- The ECN number in the attributes_T_request/confirm shall be set to zero ("0").
- The LBN number in the attributes_T_request/confirm shall be set to "15".

The new (basic) connection shall be identified only by the same MCEI which identified the old (advanced) connection.

10.3.4 Modulation type modification

The modulation type modification defined by this clause can only be used to modify the modulation type of the B-field while keeping a 2-level modulation for the A-field.

At MAC layer, the modulation type modification procedure shall always be PT initiated.

The modulation scheme is associated to a physical connection. A physical connection is always set-up using the default modulation scheme (see note 1) and might be switched to a higher layer negotiated modulation scheme afterwards using the procedure defined by this clause. For a multibearer connection, the modulation type negotiation can take place onto one of the duplex bearers of the connection.

All the bearers of a MAC connection shall always be setup by using the default modulation scheme (see note 1); in case a different modulation scheme has been negotiated (e.g. a high level one) for the associated physical connection, this shall be used onto the new bearer immediately after bearer establishment (for the definition of "Bearer established", see clause 10.5). This rule applies for bearer handover as well. In case of connection handover, and if the required modulation scheme is different from the default one, the modulation type modification procedure defined by this clause shall be started again.

NOTE 1: The "default" modulation scheme is profile dependant.

Procedure description:

PT side:

- The DLC layer of the initiating side shall start the modulation type modification procedure by issuing the MAC_MOD-req primitive, with the required modulation type, to the MAC layer.
- At the MAC_MOD-req primitive detection, the MBC shall send, in the next allowed frame, the appropriate Attributes_T_request message (see clause 7.2.5.3.8 for coding) to the peer entity.
- This is repeated in up to five successive allowed frames or until the PT receives the attributes_T_confirm message. If the attributes_T_confirm is not received after five retransmissions of the attributes_T_request message, the PT shall release the connection and the DLC layer is informed using the MAC_DIS-ind primitive.
- As soon as the Attributes_T_confirm message is detected, the MBC shall issue the MAC_MOD-cfm primitive, with the negotiated modulation scheme, to the DLC layer.
- The PT shall acknowledge the receipt of the attributes_T_confirm message by the transmission of another message in the next TDMA frame. For this procedure the other message means any other message than a MAC release message or a repeated attributes_T_request message in a frame suitable for retransmission of the attributes_T_request message.

FT side:

- At the detection of the Attributes_T_request message, the MBC shall issue the MAC_MOD-ind primitive, with the required modulation type, to the DLC layer.
- The DLC can either decide to release the connection, (e.g. in case the required modulation scheme is not acceptable for the service) or shall send the MAC_MOD-res primitive, with the agreed modulation type, to the MAC layer.
- At the reception of the MAC_MOD-res primitive, the MBC shall send, in the next allowed frame, the appropriate Attributes_T_confirm message (see clause 7.2.5.3.8 for coding) to the peer entity.
- The MBC shall confirm all the following Attributes_T_request messages which it can receive after the first Attributes_T_confirm message has been sent.

NOTE 2: The Attributes_T_confirm message is detected if message type decoded and modulation type indication coincident with the required one.

For the timing, when to switch to the new service type, the following rules shall apply.

The attributes_T_confirm message is the first burst sent by the FT using the new modulation type. All following bursts sent by the FT shall use the new modulation type. The PT may process received data according to the new modulation type starting from that burst containing the attributes_T_confirm message. From that TDMA frame where the first attributes_T_confirm message is expected up to the first error free received attributes_T_confirm message, received B-field data should be ignored due to the uncertain modulation type used.

The other message is the first burst sent by the PT using the new modulation type. All following bursts sent by the PT shall use the new modulation type. The FT may process received data according to the new modulation type starting from that burst containing the other message. From that TDMA frame where the first other message is expected up to the first error free received other message, received B-field data should be ignored due to the uncertain modulation type used.

10.3.4.1 Adaptive code rate

If Turbo Code channel coding is used, then in addition to the procedure described above the following procedure shall apply:

Procedure description:

PT side:

- At the MAC_MOD-req primitive detection, the appropriate adaptive code rate shall be determined and the MBC shall send, in the next allowed frame, the appropriate Attributes_T_request message (see clause 7.2.5.3.8 for coding) to the peer entity.
- As soon as the Attributes_T_confirm message is detected, the MBC shall issue the MAC_MOD-cfm primitive, with the negotiated modulation scheme and the negotiated adaptive code rate to the DLC layer.

FT side:

- At the detection of the Attributes_T_request message, the MBC shall issue the MAC_MOD-ind primitive, with the required modulation type and the required adaptive code rate to the DLC layer.
- The DLC can either decide to release the connection, (e.g. in case the required modulation scheme is not acceptable for the service) or shall send the MAC_MOD-res primitive, with the agreed modulation type and the agreed adaptive code rate, to the MAC layer.

10.4 C/O connection release

10.4.1 General

Connection release is the last phase of a connection orientated MAC service. During connection release an existing MBC will be released. This action is reported to the LLME and to the DLC if necessary.

Several events can cause a release of an established connection:

- a) the DLC of either side issues a MAC_DIS-req primitive to the MBC;
- b) during connection setup, an MBC was created for a service which is not provided by the MAC (e.g. I_P data service requested on an FT which supports only I_N services);
- c) due to a bearer release, a TBC reports "connection_release" to the MBC (i.e. in the received RELEASE message the reason was set to "connection_release");
- d) as a result of bearer release, no TBC controlling a duplex bearer exists;
- e) due to a bearer release, the MBC cannot maintain the minimum acceptable service.

In packet mode connections, including ULE, the events d) and e) do not cause a connection release. They are part of a connection suspend procedure.

The events d) and e) do not cause a connection release if the service allows a suspension connection procedure. In this case, the MBC will inform the LLME.

Event a) describes the initiation of a normal connection release. The DLC of either side decides to release the connection. As a consequence, one of the events c), d) or e) will cause a connection release at the opposite side.

During connection setup, event d) does not normally cause a connection release at the calling side. Before the MAC_CON-cfm primitive is issued to the DLC the event d) only causes a connection release when the TBC reports that the MAC service cannot be provided to the MBC. Without this report the MBC may reattempt the bearer setup (see clause 10.2.4).

Events d) and e) may occur at any time due to a bearer failure.

NOTE: A bearer release will be the consequence if a bearer fails.

10.4.1.1 C/O connection release in packet mode connections

In packet mode connections, including ULE, a bearer release does not automatically cause the release of the connection, which is preserved at MBC level. Connection release (defined as the complete release of the MBC) is achieved by the following procedures:

- By execution of a NWK layer CC Release procedure. This is the normal release procedure and causes the liberation in sequence of NWK, DLC, MBC and TBC layer resources.
- Exceptionally, by the ME, for instance due to repeated failures in the stay-alive or other error handling procedures. The ME may liberate resources at any layer.
- In systems not implementing a complete NWK layer (such as DPRS [9] Class 1 systems or ULE systems using PVCs), by configuration actions.

10.4.2 Procedure description

If an MBC receives a MAC_DIS-req primitive from its DLC the MBC initiates a bearer release on all TBCs and disconnects the TBCs. The MAC releases the MBC and reports this event to the LLME.

During connection setup, one of the MBCs may be asked to provide a service that cannot be provided by its MAC layer. In this case that MBC initiates bearer release at all TBCs and then disconnects these TBCs. A MAC Layer issues a MAC_DIS-ind if it has received a MAC_CON-req or already issued a MAC_CON-ind. The MAC releases the MBC and reports this event to the LLME.

A TBC may report bearer released to the MBC for several reasons, e.g. bearer failed due to a timeout or release message received. The MBC disconnects this TBC and tests if:

- the last duplex bearer has been released;
- the wanted service cannot be provided further;
- the TBC indicated a connection release.

The occurrence of at least one of these events will normally cause a connection release (exception see clause 10.4.1, comment to events d) and e)). The MBC initiates a bearer release on all remaining TBCs and disconnects the TBCs. A MAC layer issues a MAC_DIS-ind if it has received a MAC_CON-req or already issued a MAC_CON-ind. The MAC releases the MBC and reports this event to the LLME.

10.5 C/O bearer setup

10.5.1 Single bearer setup procedures

In the following procedures, the set of messages used to switch the bearer state to Bearer_Established after the confirm message has been received are called the "other" messages. The "other" messages comprise all messages except release.

10.5.1.1 Basic bearer setup procedure

Predicates:

- a) PT is in frame and multiframe synchronism with a cluster. The PT has already received the RFPI of at least one RFP within this cluster and knows the RFP's receiver scanning sequence;
- b) an MBC has been created in the PT's MAC to control a connection. The MBC has knowledge of at least one available channel and knows the FMID of the desired RFP;
- c) the PT's MBC has created a new TBC in order to set-up a new bearer. The MBC has issued the PMID, FMID and the physical channel identification to the TBC. The MBC indicated if the wanted bearer is to be used for a bearer handover, resumption of a suspended connection, bearer replacement or a new connection, and whether the connection is "normal" or a "handover".

Procedure Description:

This procedure is always PT initiated and based on the exchange of:

- a "bearer_request" message from PT to FT; followed by
- a "bearer_confirm" message from FT to PT; followed by
- an "other" message from PT to FT; followed by
- an "other" message from FT to PT.

The "bearer_request" message is one of the following messages defined in clause 7.2.5.2:

- the ACCESS_REQUEST message;
- the BEARER_HANDOVER_REQUEST message;
- the CONNECTION_HANDOVER_REQUEST message.

The "bearer_confirm" message is:

- the BEARER_CONFIRM message from clause 7.2.5.2.

The messages are carried in the tail of the A-field. The bearer request and bearer confirm messages are M_T messages of the basic connection control message set. With these messages the FT and PT exchange their MAC identities. Between request and confirm the exchange of some WAIT messages (see clause 7.2.5.2) is allowed. The FMID contained in the WAIT and the "bearer_confirm" messages shall be the same as that in the "bearer_request" message. The "other" message is used to switch the bearer state at the receiving end to Bearer_Established.

The bearer request message and the first response (confirm or WAIT message) from the called side may appear in any frame, over-riding the rules of the T-Mux algorithm described in clause 6.2.2.1. This first response of the called side shall occur in the TDMA half frame following the successful reception of the request message. Until the PT transmits the "other" message in a successful bearer setup, the MAC control messages following the request shall occupy all allowed tails for M_T . The T-Mux algorithm defines which tails are allowed. The two "other" messages are any messages over any A-field channel transmitted in successive TDMA half frames following that TDMA half frame in which the PT received the bearer confirm message.

NOTE 1: The "other" message does not need to be an M_T message. Any channel over A-field (including N_T) received without errors qualifies as "other" message.

Before Bearer_Established, the B-field may not contain valid I channel data. If valid I channel data is available, then it should be included in the B-field. When Bearer Established, the B-field shall contain valid I channel data if available. If no I channel data is available, it is recommended that all bits in the B-field are set to "F".

Independent of the current encryption mode of the connection (enabled or disabled) bearer setup always starts in "clear" (encryption disabled). In the case of bearer handover, transmissions on the new bearer are switched to the current encryption mode of the connection immediately after the second "other" message was transmitted/received.

Procedure:

- 1) PT transmits one "bearer_request" at the right time on a given available channel (selection defined in clause 11.4.2) to one of its known RFPs using the "first PT transmission" header code given in clause 7.1.2.
- 2) FT receives "bearer_request" error free (see note 2) with correct FMID and creates a new TBC else procedure ends (bearer setup failed, no TBC = no further transmissions).

NOTE 2: Receiving without error means, A-field and X-field CRC hold and message is recognized (message type decoded). When WAIT-messages are used during the setup procedure, the following definition of error free is allowed: For the first four transmissions (two in each direction) on a bearer, A-field CRC and X-field CRC hold and message is recognized (message type decoded). For the following transmissions until "bearer_established": At least one out of every two successive expected Mt-messages is recognized (message type decoded) and A-field CRC holds.

NOTE 3: It is assumed that an FT which does not have the capacity to create a new TBC (e.g. simple residential system, call in progress, no bearer or connection handover capability) is not listening to bearer request messages and, therefore, cannot receive this message. If the MBC can create a new TBC this FMID check has to be done within one TDMA half frame = 5 ms. The PT may try to access another base station on reception of a release message in the half-frame immediately following the bearer request instead of wait or bearer confirm.

- 3) FT's TBC asks LLME for an MBC identified by (ARI + PMID) to be connected. If the FT cannot provide an MBC the procedure ends (bearer setup failed, see note 4).

```
-----
WHILE (FT not ready to transmit "bearer_confirm") DO BEGIN
  a) FT sends WAIT;
  b) If the PT receives WAIT error free:
      then the PT responds with WAIT;
      else procedure ends (bearer setup failed).
```

If WAIT messages were received before, the PT should release the TBC by using a bearer release procedure. Otherwise the TBC shall stop transmissions and the PT should release the TBC.

- ```
 c) If the FT receives WAIT message error free:
 then continue;
 else procedure ends with FT initiating bearer release (bearer setup failed).
```

```
END {WHILE}

```

- 4) FT sends "bearer\_confirm".
- 5) If the PT receives "bearer\_confirm" error free:
  - then the PT sends immediately "other" (see note 5);
  - else the procedure ends (bearer setup failed).

If WAIT messages were received before, the PT should release the TBC by using a bearer release procedure. Otherwise the TBC shall stop transmissions and the PT should release the TBC.

- 6) If the FT receives "other" with errors or a release:
  - then the FT initiates bearer release (bearer setup failed);
  - else the TBC reports "bearer\_established" to the MBC, and the FT sends immediately "other" (see note 5).
- 7) If the PT receives "other" with errors or a release:
  - then the PT initiates bearer release (bearer setup failed);
  - else the TBC reports "bearer\_established" to the MBC.

NOTE 4: The FT should release the TBC with a bearer release procedure.



If WAIT messages were received before, the PT should release the TBC by using a bearer release procedure. Otherwise the TBC shall stop transmissions and the PT should release the TBC.

NOTE 5: "Immediately" means, in the TDMA half frame following the transmission of the "bearer\_confirm" message (step 5 above) or of the first "other" message (step 6 above).

NOTE 6: During bearer handover and connection handover with encryption from a RFP to a CRFP it is allowed that the FT and CRFP exchange higher layer messages and start messages between the bearer\_handover.req message (PT PMID) and the bearer.cfm message.

### 10.5.1.2 A-field advanced single bearer setup procedure

The A-field advanced single bearer setup procedure may be initiated from either side, PT or FT.

#### 10.5.1.2.1 PT initiated

##### **Predicates:**

- a) PT is in frame and multiframe synchronism with a cluster. The PT has already learned the RFPI of at least one RFP within this cluster and knows the RFP's receiver scanning sequence;
- b) an MBC has been created in the PT's MAC to control a connection. The MBC has knowledge of at least one available channel and knows the FMID of the wanted RFP;
- c) the PT's MBC has created a new TBC in order to set-up a new bearer. The MBC has issued the PMID, FMID, ECN, the channel identification and a LBN to the TBC. The MBC indicated if the wanted bearer is to be used for a bearer handover or a new connection, and whether the connection is "normal" or a "handover".

##### **Procedure description:**

This procedure is based on the exchange of:

- a "bearer\_request" message from PT to FT; followed by
- a "bearer\_confirm" message from FT to PT; followed by
- an "attributes\_request" message from PT to FT; followed by
- an "attributes\_confirm" message from FT to PT; followed by
- an "other" message from PT to FT; followed by
- an "other" message from FT to PT.

The "bearer\_request" message is one of the following messages defined in clause 7.2.5.3:

- the ACCESS\_REQUEST message;
- the BEARER\_HANDOVER\_REQUEST message;
- the CONNECTION\_HANDOVER\_REQUEST message.

The "bearer\_confirm" message is:

- the BEARER\_CONFIRM message of clause 7.2.5.3.

The "attributes\_request" message is:

- the ATTRIBUTES\_T message (see clause 7.2.5.3). The Request/Confirm (R/C) bit is set to 0.

The "attributes\_confirm" message is:

- the ATTRIBUTES\_T message (see clause 7.2.5.3). The Request/Confirm (R/C) bit is set to 1.

All service parameters in the ATTRIBUTES\_T messages used as the "attributes\_request" and "attributes\_confirm" messages shall be the same. The only difference is the setting of the R/C bit.

The messages are carried in the tail of the A-field. Except for the "other" message all messages are  $M_T$  messages of the advanced control message set. With the  $M_T$  messages the FT and PT exchange their MAC identities and agree the service type. Between the needed setup messages the exchange of some WAIT messages (see clause 7.2.5.3) is allowed. The FMID contained in the WAIT and the "bearer\_confirm" messages shall be the same as that in the "bearer\_request" message. The "other" message is used to switch the bearer state at the receiving end to Bearer\_Established.

The bearer request message and the first response (confirm or WAIT message) from the called side may appear in any frame, overriding the rules of the T-Mux algorithm described in clause 6.2.2.1. This first response of the called side shall occur in the TDMA half frame following the successful reception of the request message. Until the PT transmits the "other" message in a successful bearer setup, the MAC control messages following the request shall occupy all allowed tails for  $M_T$ . The T-Mux algorithm defines which tails are allowed. The "other" messages are any messages over any Afield channel transmitted in successive TDMA half frames following that half frame in which the PT received the bearer confirm message.

NOTE 1: The "other" message does not need to be an  $M_T$  message. Any channel over A-field (including  $N_T$ ) received without errors qualifies as "other" message.

Before Bearer\_Established, the B-field need not contain valid I channel data. If the U-type multiplex is used during setup and no valid I channel data is available, it is recommended that all bits in the B-field are set to "0".

Independent of the current encryption mode of the connection (enabled or disabled) bearer setup starts always in "clear" (encryption disabled). In case of bearer handover, transmissions on the new bearer are switched to the current encryption mode of the connection immediately after the second "other" message was transmitted/received.

#### Procedure:

- 1) PT transmits one "bearer\_request" at the right time on a given available channel (selection defined in clause 11.4.2) to one of its known RFPs using the "first PT transmission" header code given in clause 7.1.2.
- 2) FT receives "bearer\_request" error free (see note 2) with correct FMID and creates new TBC else procedure ends (bearer setup failed, no TBC = no transmissions).

NOTE 2: Receiving without error means A-field and X-field CRC hold and message is recognized (message type decoded). When WAIT-messages are used during the setup procedure, the following definition of error free is allowed: For the first four transmissions (two in each direction) on a bearer, A-field CRC and X-field CRC hold and message is recognized (message type decoded). For the following transmissions until "bearer\_established": At least one out of every two successive expected  $M_t$ -messages is recognized (message type decoded) and A-field CRC holds.

---

```

WHILE (FT not ready to transmit "bearer_confirm") DO BEGIN
 a) FT sends WAIT.
 b) If the PT receives WAIT error free:
 then the PT responds with WAIT;
 else procedure ends (bearer setup failed).

```

If WAIT messages were received before, the PT should release the TBC by using a bearer release procedure. Otherwise the TBC shall stop transmissions and the PT should release the TBC.

```

 c) If the FT receives WAIT message error free:
 then continue;
 else procedure ends with FT initiating bearer release (bearer setup failed).

```

```

END {WHILE}

```

---

- 3) FT sends "bearer\_confirm".
- 4) If the PT receives "bearer\_confirm" error free:
  - then continue;
  - else the procedure ends (bearer setup failed).

-----  
 If WAIT messages were received before, the PT should release the TBC by using a bearer release procedure. Otherwise the TBC shall stop transmissions and the PT should release the TBC.

```

WHILE (PT not ready to transmit "attributes_request") DO BEGIN
 a) PT sends WAIT.
 b) If the FT receives WAIT error free:
 then the FT responds with WAIT;
 else procedure ends (bearer setup failed), with the FT initiating a bearer release.
 c) If the PT receives WAIT message error free:
 then continue;
 else procedure ends (bearer setup failed) with the PT initiating a bearer release.
END {WHILE}

```

-----

- 5) PT sends "attributes\_request".
  - 6) FT receives "attributes\_request" error free else procedure ends (bearer setup failed) with FT initiating a bearer release.
  - 7) FT's TBC asks LLME for an MBC identified by (ARI + PMID + ECN) to be connected. If the FT cannot provide an MBC the procedure ends (bearer setup failed) with FT initiating a bearer release.
  - 8) FT's TBC asks MBC for connection with the received logical bearer number (LBN). If the MBC cannot accept a new bearer with this LBN the procedure ends (bearer setup failed) with FT initiating a bearer release.
- 

```

WHILE (FT not ready to transmit "attributes_confirm") DO BEGIN
 a) FT sends WAIT.
 b) If PT receives WAIT error free:
 then the PT responds with WAIT;
 else procedure ends (bearer setup failed) with PT initiating a bearer release.
 c) If FT receives WAIT message error free:
 then continue;
 else procedure ends with FT initiating bearer release (bearer setup failed).
END {WHILE}

```

-----

- 9) FT sends "attributes\_confirm".
- 10) If PT receives "attributes\_confirm" without error:
  - then continue;
  - else the procedure ends (bearer setup failed) with PT initiating bearer release.

NOTE 3: It is assumed that an FT which does not have the capacity to create a new TBC (e.g. simple residential system, call in progress, no bearer or connection handover capability) is not listening to bearer request messages and, therefore, cannot receive this message. If the MBC can create a new TBC this FMID check has to be done within one TDMA half frame = 5 ms.

- 11) PT sends immediately "other" (see note 4).
- 12) If the FT receives "other" with errors or a release:
  - then the FT initiates bearer release (bearer setup failed);
  - else the TBC reports "bearer\_established" to the MBC.
- 13) FT sends immediately "other" (see note 4).
- 14) If the PT receives "other" with errors or a release:
  - then the PT initiates bearer release (bearer setup failed);
  - else the TBC reports "bearer\_established" to the MBC.

If WAIT messages were received before, the PT should release the TBC by using a bearer release procedure. Otherwise the TBC shall stop transmissions and the PT should release the TBC.

NOTE 4: "immediately" means, In the TDMA half frame following the transmission of the "attributes\_confirm" message (step 11) or of the first "other" message (step 13).

NOTE 5: During bearer handover and connection handover with encryption from a RFP to a CRFP it is allowed that the FT and CRFP exchange higher layer messages and start messages between the bearer\_handover.req message (PT PMID) and the bearer.cfm message.

#### 10.5.1.2.2 FT initiated

##### Predicates:

1) For setting up the first bearer of a connection:

- a) the PT is location registered with the FT and has informed the FT of the RFPI of the RFP that it was locked to;
- b) the PT is scanning all channels of the FT, using a scan sequence that is known by the FT;

NOTE 1: This is the PT "fast setup" scan sequence, that is different to the FP primary scan sequence (see clause 11.9).

- c) an MBC has been created in the FT's MAC to control a connection. The MBC has knowledge of at least one available channel;
- d) the FT's MBC has created a new TBC in order to set-up a new bearer. The MBC has issued PMID, FMID, ECN, the physical channel identification and a new LBN for this connection to the TBC.

2) For setting up additional duplex bearer to a multibearer connection:

- a) there is an already setup a duplex bearer between the PT and the FT;
- b) the PT either:
  - 1) has send a LISTEN command to the FT on an existing duplex bearer; or
  - 2) has received a START command on an existing duplex bearer; or
  - 3) is scanning all channels of the FT using a scan sequence that is known by the FT;

NOTE 2: This is the PT "fast setup" scan sequence, that is different to the FP primary scan sequence (see clause 11.9).

NOTE 3: The option 3 forces the PT to keep its receiver active in all slots. Depending of the application, this option can be allowed or disabled by the relevant application profile, making in the last case the use of channel list messages mandatory.

- c) the FT's MBC has created a new TBC in order to setup a new bearer. The MBC has issued PMID, FMID, ECN, the physical channel identification and a new LBN for this bearer to the TBC.

##### Procedure description:

Same as in clause 10.5.1.2.1 with the following two exceptions:

- change transmission direction of all messages;
- the "bearer\_request" message cannot be the BEARER\_HANDOVER\_REQUEST message or the CONNECTION\_HANDOVER\_REQUEST message as defined in clause 7.2.5.3. Bearer handover and connection handover of a duplex bearer is always initiated by the PT.

##### Procedure:

Same procedure as PT initiated with following changes:

- exchange names PT and FT in procedure steps;
- change PMID in step 2 to FMID.

Step 1 is changed to:

- FT transmits one "bearer\_request" at the right time on a given available channel (selection defined in clause 11.4.3) to its known PT.

### 10.5.1.3 B-field single bearer setup procedure

The B-field single bearer setup procedure may be initiated from either side, PT or FT.

#### 10.5.1.3.1 PT initiated

During bearer setup the A-field tail messages follow the normal T-MUX rules, except for the first transmission of the PT. The first transmission of the PT is labelled in the header's tail identification and the tail carries a  $M_T$  message indicating that the connection uses B-field setup (see clause 7.2.5.8).

#### **Predicates:**

The same as in clause 10.5.1.2.

#### **Procedure description:**

This procedure is based on the exchange of:

- a "bearer\_request" message from PT to FT; followed by
- a "bearer\_confirm" message from FT to PT; followed by
- an "other" message from PT to FT; followed by
- an "other" message from FT to PT.

The "bearer\_request" message is:

- the BEARER\_REQUEST message of clause 7.3.2.2 where the second header indicates ACCESS\_REQUEST, BEARER\_HANDOVER\_REQUEST or CONNECTION\_HANDOVER\_REQUEST.

The "bearer\_confirm" message is:

- the BEARER\_CONFIRM message of clause 7.3.2.3.

All service parameters in the bearer request and the bearer confirm message shall be the same.

The messages shall be carried in the  $B_0$  subfield and may also be carried in other subfields. The bearer request and bearer confirm messages are extended MAC control. Between request and confirm the exchange of some WAIT messages (B-field Advanced connection control set see clause 7.3.2.4) are allowed and, if used, shall be carried in the  $B_0$  subfield. The FMID contained in the WAIT and the "bearer\_confirm" messages shall be the same as that in the "bearer\_request" message. The "other" message is used to switch the bearer state at the receiving end to Bearer\_Established.

The first response of the called side (bearer\_confirm or wait) shall occur in the TDMA half frame following the successful reception of the request message.

The "other" messages are any messages over any A-field or B-field channel transmitted in successive TDMA half frames following that TDMA half frame in which the PT received the bearer confirm message.

NOTE 1: The "other" message does not need to be a B-field message. Any channel over A-field (including  $N_T$ ) received without errors qualifies as "other" message.

If the "other" messages are  $M_T$ , the operation performed by these messages is conditional to the success of the bearer setup procedure.

It is allowed to send additional B-field MAC commands during the bearer setup procedure. However, the procedure performed by them is conditional to the success of the bearer setup procedure and shall be rolled back if the setup fails.

It is allowed to transmit U-plane data (I channel) in the B-field of the "other" frames. However, transmission is conditional to the success of the bearer setup procedure: if the procedure fails, the R-side shall discard the packet and the T-side shall act as if the packet were not transmitted.

Independent of the current encryption mode of the connection (enabled or disabled) bearer setup starts always in "clear" (encryption disabled). In case of bearer handover, transmissions on the new bearer are switched to the current encryption mode of the connection immediately after the second "other" message was transmitted/received.

**Procedure:**

- 1) PT transmits one "bearer\_request" at the right time on a given available channel (selection defined in clause 11.4.2) to one of its known RFPs.
- 2) FT receives "bearer\_request" error free with correct FMID and creates new TBC else procedure ends bearer setup failed, no TBC = no transmissions).

NOTE 2: It is assumed that an FT which does not have the capacity to create a new TBC (e.g. simple residential system, call in progress, no bearer or connection handover capability) is not listening to bearer request messages and, therefore, cannot receive this message. If the MBC can create a new TBC this FMID check has to be done within one TDMA half frame = 5 ms.

- 3) FT's TBC asks LLME for an MBC identified by (ARI + PMID + ECN) to be connected. If the FT cannot provide an MBC the procedure ends (bearer setup failed).
- 4) FT's TBC asks MBC for connection with the received logical bearer number (LBN). If the MBC cannot accept a new bearer with this LBN the procedure ends (bearer setup failed).

```

WHILE (FT not ready to transmit "bearer_confirm") DO BEGIN
 a) FT sends WAIT;
 b) If PT receives WAIT error free:
 then PT responds with WAIT;
 else procedure ends (bearer setup failed);
 c) If FT receives WAIT message error free:
 then continue;
 else procedure ends with FT initiating bearer release (bearer setup failed).
END {WHILE}

```

- 5) FT sends "bearer\_confirm".
- 6) If PT receives "bearer\_confirm" without error:
  - then continue;
  - else the procedure ends (bearer setup failed).
- 7) PT sends immediately "other".
- 8) If the FT receives "other" with correct A-field and X-field CRCs:
  - then the TBC reports "bearer\_established" to the MBC;
  - else the FT initiates bearer release (bearer setup failed).
- 9) FT sends immediately "other".
- 10) If the PT receives "other" with correct A-field and X-field CRCs:
  - then the TBC reports "bearer\_established" to the MBC;
  - else the PT initiates bearer release (bearer setup failed).

In the preceding procedure the wording "Immediately" means, in the TDMA half frame following the transmission of the "bearer\_confirm" message (step 7) or in the TDMA half frame following the transmission of the first "other" message (step 9).

In the preceding procedure the expression "Received error free" means that the A-field and the B<sub>0</sub>-subfield shall be received without CRC error. When WAIT-messages are used during the setup procedure, the following definition of error is allowed: for the first four transmissions (two in each direction) on a bearer, A-field CRC and B<sub>0</sub>-subfield hold and message is recognized (message type decoded). For the following transmissions until "bearer\_established": at least one out of every two successive expected MAC B-field advanced\_connection control set messages is recognized (message type decoded) and A-field and B<sub>0</sub>-subfield CRC holds.

In case of the bearer setup failure is detected at the FT side, the FT should release the TBC with an FT initiated bearer release procedure.

In case of the bearer setup failure is detected at the PT side and when WAIT messages were exchanged before, the PT should release the TBC by using a PT initiated bearer release procedure. Otherwise the TBC shall stop transmissions and the PT should afterwards release the TBC.

Although the relevant MAC messages (bearer request, bearer confirm, WAIT and release) shall be located in B<sub>0</sub>-subfield, duplication of these messages is allowed in other B<sub>n</sub>-subfields.

NOTE 3: During bearer handover and connection handover with encryption from a RFP to a CRFP it is allowed that the FT and CRFP exchange higher layer messages and start messages between the bearer\_handover.req message (PT PMID) and the bearer.cfm message.

#### 10.5.1.3.2 FT initiated

During bearer setup the A-field tail messages follow the normal T-MUX rules.

##### **Predicates:**

Same as in clause 10.5.1.2.2.

##### **Procedure description:**

Same as in clause 10.5.1.3.1 with the following two exceptions:

- change transmission direction of all messages;
- the "bearer\_request" message cannot be the BEARER\_HANDOVER\_REQUEST message or the CONNECTION\_HANDOVER\_REQUEST message as defined in clause 7.2.5.3. Bearer handover and connection handover of a duplex bearer is always initiated by the PT.

##### **Procedure:**

Same procedure as PT initiated with following changes:

- exchange names PT and FT;
- change FMID in step 2 to PMID;
- step 1 changes to;
- FT transmits one "bearer\_request" at the right time on a given available channel (selection defined in clause 11.4.3) to its known PT.

#### 10.5.1.4 Double simplex setup procedure

##### 10.5.1.4.1 Terminology and Predicates

##### **Terminology:**

**T-side:** the side that will be the eventual transmitter of the double simplex bearer.

**R-side:** the side that will be the eventual receiver of the double simplex bearer.

**Predicates:**

- a) the connection (or the MBC) already exists, i.e. a double simplex bearer shall only be added to an existing connection. At least one (pilot) duplex bearer shall be controlled by this connection;
- b) the wanted service is known at both endpoints. To provide the wanted service an asymmetric connection is to be used;
- c) the T-side knows the FT's ARI, the PT's PMID, the ECN and the LBN of the wanted bearer. It also knows if the wanted bearer is to be used for a bearer handover or for a connection setup, and whether the connection setup is for handing over a connection.

#### 10.5.1.4.2 General description

The procedure has two phases:

- selection of suitable physical channels;
- bearer setup using those channels.

There are two methods of double simplex bearer setup: indirect setup, and direct setup.

The indirect double simplex bearer setup is based on the R-side transmission of a single "dummy" message on that physical channel of the channel pair which lies in the normal R-side transmit half-frame. When received without error, the T-side may proceed with the direct bearer setup procedure starting the double simplex transmissions on the same channel pair in the next TDMA frame.

The "dummy" message is the following message:

- the UNCONFIRMED\_DUMMY message defined in clause 7.2.5.3 (A-field setup) and clause 7.3.2.8 (B-field setup): Sent by the R-side.

The direct double simplex bearer setup is based on the exchange of the following messages:

- the LISTEN channel list message sent by the R-side; or
- the START channel list message sent by the T-side; together with
- the "bearer\_request" messages transmitted by the T-side; followed by
- the "attributes" message transmitted by the T-side (see note 1); followed by
- the ACTIVE channel list message received by the T-side.

NOTE 1: The "attributes" message occurs only in A-field setup.

NOTE 2: The LISTEN or START channel list messages, when used to initiate the procedure, are sent on a already established bearer.

NOTE 3: The ACTIVE channel list message is transmitted on any duplex bearer.

The "bearer\_request" message is the following message:

- the UNCONFIRMED\_ACCESS\_REQUEST message defined either in clause 7.2.5.3 (A-field setup) or in clause 7.3.2.2 (B-field setup).

The "attributes" message for A-field setup is:

- the ATTRIB\_T message (see clause 7.2.5.2). The Request/Confirm (R/C) bit is set to 0.



### 10.5.1.4.3 Channel selection procedure for circuit mode connections

Prior to initiating an Indirect Setup, the R-side shall select a channel using the double simplex channel procedures as described in clause 11.4. The T-side shall not select the channel.

Although the R-side only makes a single (backward) transmission, the channel selection shall use the double simplex procedure.

The R-side should select other suitable physical channels for setup, and should indicate these to the T-side using indirect setup (the "dummy" message) or GOOD or LISTEN channel list messages.

NOTE 1: These channel list messages may be transmitted on any existing bearer of this connection, and may be  $M_T$  messages or extended MAC control.

The T-side always initiates the double simplex transmissions as described in the direct setup procedure. When initiating this procedure, the T-side should give preference to accepting any indirect setup procedures from the R-side.

When selecting channels for the direct procedure (i.e. when not responding to an indirect setup transmission) the T-side should select a channel in the following order of preference:

- a) a channel indicated by a LISTEN message;
- b) any channel that is aligned to a predefined R-side scanning pattern (see clause 11.8 for RFPs, and clause 11.9 for PPs);
- c) a channel indicated by a GOOD message.

In these cases the T-side channel selection shall use the double simplex channel selection procedures as described in clause 11.4.

Before selecting a physical channel, the T-side should attempt to receive one (or more) transmission on that channel. If a connectionless or broadcast transmission is received as indicated by the BA coding (see clause 7.1.4) the physical channel should not be used.

NOTE 2: Connectionless and broadcast transmissions should be given special treatment, to improve their reliability.

### 10.5.1.4.4 Channel selection procedure for packet mode connections

For Packet mode services the following modifications compared to the circuit-mode case shall apply:

#### **Double simplex bearers PT => FT direction**

For double simplex bearers in PT => FT direction, the procedure shall be as in circuit mode case with the only difference that the channel selection done by the R-side (FT) could be based on specific algorithms for packet connections, instead of following the double simplex channel procedures described in clause 11.4.

NOTE 1: FT channel selection algorithm is not standardized.

The R-side shall use preferably the channel list message "LISTEN" to communicate available channels to the T-side and to initiate the setup procedure.

NOTE 2: The R-side (FT) should consider as primary choices for channel selection, those channels that have been successfully used by the connection in previous active phase and that are now free in the FT.

#### **Double simplex bearers FT => PT direction**

For double simplex bearers in FT => PT direction, the channel selection shall be done by the T-side (FT) after proposal sent by R-side (PT).

The R-side shall use preferably the channel list message "GOOD" to communicate suggested channels to the T-side. The T-side shall use the command "START" to indicate the chosen channels and to initiate the setup procedure.

The FT behaviour regarding the channel selection shall depending on the case:

- **Case a)** initial setting of double simplex bearers after initial call setup, or expansion of the bandwidth by first time or after long time of no use, or resume after a long time of connection suspension.

In general, this rule shall apply in cases when the FT needs to find additional channels/slots not previously used by the connection, or not used during "long time".

In this case, the FT channel selection shall be based on the proposals sent by the PT by means of the GOOD or other channel list commands.

In absence of channel list info sent by the PT, or if the FT prefer to use other channel, the FT shall query the PT by means of the QUERY\_N command to retrieve this information.

The FT shall also take into account the internal use of slots/channels by other terminals.

- **Case b)** resumes after a short time or connection suspension, OR bandwidth expansion after short time of operation with reduced bandwidth.

In this case, the FT shall use as first choice, the same slot/channels used successfully for communications with this PT in the "short time" (see notes 3 and 4), if they are free and usable in the FT at the time of bearer setup.

The second choice shall be channels communicated by the R-side by means of the GOOD and other channels list commands, in the same way as case a).

In all cases, the FT shall also take into account the internal use of slots/channels by other terminals.

In choice 1, the FT does not need to follow the channel list commands sent by the PT, and can initiate the setup using the START command, even without waiting for PT channel list information.

NOTE 3: The value of what is a "long time" and "short time" is left to the implementer. A correct value should be related to both: the average duration of a telephone call, and the DECT channel list updating. A recommended value for the boundary short/long is in the range of a few minutes.

NOTE 4: "used successfully" for "communication" means that they were not released due to poor quality.

NOTE 5: The reason of this specific behaviour for packet communications is that the FT has better view of the channels used or free at a given time. The PT sees as busy any channel shared with other PTs in packet mode, even if it is free at the time of setup.

#### 10.5.1.4.5 Indirect setup procedure

The indirect procedure enables the R-side to propose a channel to set-up a double simplex bearer. Nevertheless, it is the T-side's responsibility to accept the proposal.

##### **R-side proposal:**

The R-side shall initiate the set-up by transmitting a "dummy" message in the normal half of the TDMA frame. This transmission shall be aligned to a known T-side scanning pattern (see clauses 11.8 and 11.9). The R-side shall then attempt to receive a direct double simplex set-up on these channels as though a LISTEN message had been sent (i.e. the R-side shall listen to the channel for 4 TDMA frames).

If the "dummy" message is received successfully by the T-side, the T-side should initiate a direct double simplex setup on that channel using the procedure listed below. If the T-side responds to this "dummy" transmission, it shall commence double simplex transmissions in the TDMA frame immediately following the TDMA frame that contained the DUMMY message.

#### 10.5.1.4.6 Direct setup procedure

The procedure can be performed in two ways, depending whether the R-side has sent, or not, the LISTEN command in the previous channel selection phase.

##### 10.5.1.4.6.1 Direct setup, initiated by LISTEN

The transmission of the channel list message LISTEN by the R-side, means that the R-side has activated a receiver in the indicated bearers, and thus, can be considered the beginning of the procedure.

NOTE 1: The LISTEN command can be transmitted either in A-field or B-field. The B-field transmission allows to initiate the setting of multiple double simplex bearers at the same time (several bearers may be indicated in each channel list message, and several messages may be transmitted in one B-field).

- 1) The LISTEN command is transmitted by the R-side in A or B-field over an existing duplex bearer. The R-side shall activate temporary TBC(s) over the bearers and channels indicated in the LISTEN messages.
- 2) At the T-side, the MBC creates a TBC for each double simplex bearer indicated in the LISTEN message(s) and shall start the transmission of the command "Bearer request" (A-field or B-field) on both physical channels of the new bearers.
- 3) The T-side may optionally transmit the channel list command START. This is only mandatory if it is used as synchronization point for the encryption. The START command may be transmitted either:
  - a) Over an existing duplex bearer in the same TDMA frame of the first attempt of the "Bearer request" message(s).
  - b) If B-field setup is used, over the same double simplex bearer in process of setting.

The START command shall be transmitted only once per bearer and shall not be repeated.

- 4) The T-side shall repeat the transmission of "Bearer request" if needed, until the reception of the ACTIVE message from the R-side (see next step).
- 5) Upon successfully reception of the "Bearer request" message, the R-side shall send the command(s) ACTIVE over an existing duplex bearer, and shall consider the bearer as active.

NOTE 2: In B-field setup, several bearers could be reported at the same time.

- 6) Upon reception of ACTIVE, the T-side shall stop the sending of "Bearer request" and shall consider the bearer as established. U-plane transmission could start immediately.
- 7) In encrypted connections the transmissions shall be switched to "encrypted" as described below under "handling of encrypted connections".

##### 10.5.1.4.6.2 Direct setup, initiated by START

If the LISTEN command has not been transmitted, the procedure is initiated by the T-side by sending the command START. In this case, the START command shall be sent on an existing duplex bearer.

NOTE 1: A channel selection procedure may have been performed before the setup procedure with exchange of messages such as GOOD or POOR from the R-side and QUERY\_N from T-side.

- 1) The T-side shall report a setup attempt on the selected physical channels by issuing a START channel list message. This message shall be transmitted only once for one setup attempt on any bearer of this connection. The START message shall be transmitted on at least one established bearer when responding to a GOOD message (channel selection (c) above; see clause 10.5.2 for the channel list messages).

NOTE 2: The START message may be duplicated on more than one bearer, provided that all transmissions of the START message occur within a single TDMA frame.

NOTE 3: The START message may be a  $M_T$  message or extended MAC control.

- 2) At the T-side the MBC creates a TBC and shall start transmissions on both physical channels of the new bearer in the same TDMA frame if the R-side scanning pattern is known (channel selection type (b) above). Otherwise, the TBC shall start transmissions on both physical channels of the new bearer in the TDMA frame following that frame in which the START channel list message was transmitted.
- 3) In encrypted connections the transmissions shall be switched to "encrypted" as described below under "handling of encrypted connections".

#### 10.5.1.4.6.3 Direct setup, initiated by Fast Release

The Direct setup procedure is also initiated if the other peer of an existing double simplex bearer performs the Fast release procedure (transmission of the message RELEASE reason REVERSE). In this case there is no use of LISTEN or START messages. The RELEASE reason REVERSE command has the same effect of a LISTEN command for the existing physical channel of the double simplex bearer.

The R-side of the existing double simplex bearer becomes the T-side and initiates a Bearer setup procedure on the same bearer.

The procedure continues as described for the initiated by LISTEN procedure.

#### 10.5.1.4.6.4 Applicable to all modes of direct setup

##### **For A-field setup:**

The first transmissions on both channels may violate the T-MUX rules defined in clause 6.2.2.1 and at least one channel shall contain the "bearer\_request" message in the A-field tail. This message shall be labelled in the A-field header as a  $M_T$  message. The next two allowed TDMA frames for  $M_T$  tails (T-MUX algorithm) shall also be used for the bearer setup. In the first of these frames the "bearer\_request" message shall be repeated on at least one channel, and in the second the "attributes" message shall be transmitted on at least one channel.

NOTE 1: The A-field setup may transmit the "bearer\_request" message in one channel, and the "attributes" message in the other channel.

##### **For B-field setup:**

The first transmission on each channel shall contain the "bearer\_request" message. This message shall be repeated in the following TDMA frame on both physical channels of the new bearer, until the reception of the ACTIVE message. The "bearer\_request" message shall always be present in the  $B_0$  subfield and may be duplicated into other subfields.

NOTE 2: Further transmissions of the "bearer\_request" message are allowed, subject to the rules in the following clauses.

NOTE 3: The reception of the ACTIVE message defines the earliest point at which "early" U-plane data transmission may occur.

##### **Applicable to both, A-field and B-field setup:**

In certain cases the double simplex transmissions shall be limited to a maximum period of 2 TDMA frames. This limit shall apply only if the T-side has not received a GOOD, ACTIVE, or a LISTEN message for the selected double simplex channel.

NOTE 4: A suitable GOOD, ACTIVE, or LISTEN message may be received at any time up to the expiry of this transmission limit. In cases a) and c) above, the GOOD or LISTEN message will have been received before the double simplex transmissions start, and no special action is needed.

NOTE 5: In case b), a rapid response is needed from the R-side if a partial setup attempt is received by the R-side. The immediate transmission of a LISTEN message is therefore recommended.

The T-side shall now wait for a confirmation from the R-side of successful double simplex bearer establishment. A confirmation shall be indicated by the reception of an ACTIVE channel list message for this pair of physical channels on any existing bearer of the connection.

NOTE 6: This ACTIVE channel list message may also occur as a reply to a QUERY\_N or a QUERY\_H channel list message issued by the initiating side.

At the T-side the reception of the ACTIVE channel list message switches the bearer state to Bearer\_Established. If this message is not received within T212 frames after the first bearer request message was transmitted or a POOR channel list message is received for this bearer at any time during bearer setup, the bearer setup has failed and the MAC releases the new bearer with the unacknowledged release procedure (see clause 10.7.2.1).

If the T-side does not receive the ACTIVE message, it shall repeat the transmission of the "Bearer request" message until the maximum number of attempts.

NOTE 7: The maximum number of attempts may vary according to the application profile. In DPRS, the maximum number of attempts is three frames, six B-field messages.

If the T-side still does not receive the ACTIVE message, it may request the R-side state by using the QUERY\_N command.

NOTE 8: The T-side should try that before releasing the bearer by expiration of T212.

If the R-side has send the ACTIVE command, but it continues receiving "Bearer request" messages over the acknowledged bearer, it shall repeat the transmission of the ACTIVE message.

NOTE 9: The R-side should do that before releasing the bearer by expiration of T212.

At the R-side of a double simplex bearer a correctly received START channel list message may occur on any established bearer, and shall immediately alter the receiver scanning pattern if this is possible.

When a scanning change is possible, the R-side receiver scanner shall listen on the indicated pair of physical channels during at least four TDMA frames following that frame in which the START message was received. If a LISTEN message has not already been sent as part of the channel selection procedure, the R-side should immediately return a LISTEN message for the indicated channels.

NOTE 10: The LISTEN message may be transmitted in all cases.

If a change to the scanning is not possible, the R-side should respond with a POOR channel list message.

At the R-side, a "bearer\_request" message may be received on any physical channel. The physical channel should also be indicated by the receipt of a START message, but the receipt of the START message only essential in certain cases (notably for encrypted connections).

NOTE 11: The first "bearer\_request" message may occur before the START message, even for encrypted connections.

### **General:**

In all cases, successful establishment of a TBC requires the following setup messages to be received.

#### **For A-field setup:**

If a "bearer\_request" message is received on at least one channel a TBC shall be created. The TBC shall try to receive the repeated "bearer\_request" and the "attributes" messages on both physical channels. If both these messages are received within 3 frames without errors, and at least one message is received without errors on each channel, the TBC should be connected to the MBC and the bearer shall switch its state to Bearer\_Established. Otherwise, the MAC shall release the TBC.

#### **For B-field setup:**

If a "bearer\_request" message is received on at least one channel a TBC shall be created. The TBC shall try to receive the repeated "bearer\_request" message on the second simplex bearer. If this message is received within 2 frames without errors on both simplex bearers, the TBC should be connected to the MBC and the bearer shall switch its state to Bearer\_Established. Otherwise, the MAC shall release the TBC.

As soon as a new double simplex bearer TBC is established, the MBC at the receiving end shall report this event with an ACTIVE channel list message to the T-side. This message shall be transmitted on any established bearer of the connection.

If the R-side detects an unsuccessful setup attempt (i.e. at least one setup message is received for a given bearer, but the full setup criteria as given above have not been achieved), then the R-side should request an immediate halt to the setup attempt by sending a POOR channel list message.

NOTE 12: This action is not essential. The setup attempt should terminate due to lack of a positive message.

I channel data transmission may start on both physical channels as soon as there is available capacity, and the ACTIVE message has been received. Any I channel data transmitted before the bearer state is "established" (i.e. before receipt of the ACTIVE channel list message) may be lost if the bearer setup fails.

NOTE 13: Data transfer on an unestablished bearer is unreliable. In particular, the  $I_p\_error\_corrected$  service cannot return acknowledgements until it has been connected to the MBC.

#### 10.5.1.4.7 Handling of encrypted connections

There are two alternatives for marking the beginning of encryption: 1) synchronization at START and 2) synchronization at ACTIVE. The data or application profile shall decide the procedure to use. If there is no application profile, or no there is no specific mention of the method, the default procedure is the synchronization at START.

##### 10.5.1.4.7.1 Procedure 1: Synchronization at START

The use of the START message is mandatory in all cases. Transmissions on a new bearer shall start in "clear" (encryption disabled), and the transmissions shall be switched to "encrypted" at the third TDMA frame boundary after the transmission of the START message.

NOTE 1: This ensures that the next two TDMA frames, which may contain B-field setup messages, are always transmitted in "clear".

The START message is sent only one time and cannot be repeated. A successfully established TBC shall only be connected to the MBC if a START message has been received for that bearer. Otherwise the TBC shall be released.

NOTE 2: The START message is essential for encrypted connections to enable the start of encryption.

NOTE 3: In this procedure, if the transmission of the START message fails, there is no possibility to resynchronize the encryption and the bearer has to be released.

##### 10.5.1.4.7.2 Procedure 2: Synchronization at ACTIVE

The double simplex bearer setup procedure is initiated as described before either starting the procedure with START (T-side) or with LISTEN (R-side). The use of the command START is mandatory only in the first case.

The encryption synchronization event is the transmission by the R-side of the message ACTIVE over an existing duplex bearer as response to a "Bearer Request" sent by the T-side over both, or any half, of the double simplex bearers under setup.

Encryption shall start at both sides ONE frame AFTER this event.

NOTE 1: The reference point is a slot in the TDMA frame: all slots after the slot that has carried the ACTIVE message (one frame after) will be encrypted, and all slots before it are in clear. Note that the slot carrying the ACTIVE is never in question since it is part of an existing duplex bearer.

NOTE 2: If there are several double-simplex bearers in process of setup, the bearer starts encryption when acknowledged by the ACTIVE messages (it can happen in different frames).

NOTE 3: The ONE frame delay is a concession to the implementation (in order to avoid the setting of ciphering in the next slot to the one carrying ACTIVE) and also to ensure the possible reception in clear of the "Bearer request" message, in case of error in the transmission of the ACTIVE message. There are always two chances for reception of "Bearer request" in all cases.

NOTE 4: The frame "in clear" after the ACTIVE can be used, or not, for transmission of U-plane data, depending of the required security level.

NOTE 5: The transmission of the message ACTIVE in any other case (i.e. as response to a QUERY-N command) is not a synchronization mark and does not reset the ciphering: only the transmission of ACTIVE as response to a "Bearer request" sent over a double-simplex bearer in process of setup triggers the synchronization.

## Recovering procedure

In case of errors during setup, or during transmission of the ACTIVE message, the procedure can be recovered in near all cases as follows:

- If the error happened during the transmission of the "Bearer request" message, the R-side shall never send an ACTIVE message for this bearer. Therefore the T-side shall continue repeating the attempt (sending "Bearer request") until success or expiration of timers.
- If the error happened during the transmission of the "ACTIVE" message (message not received by the T-side), the T-side shall continue sending "Bearer request" on this bearer. The R-side shall respond to this case, sending again the "ACTIVE" message and resetting the encryption starting point.

NOTE 6: The R-side can always detect the command "Bearer request" sent in any of the two simplex bearers during this frame, since this is the frame "in clear".

### 10.5.1.4.7.3 Specific for non-encrypted connections

For connections which are not encrypted, a successfully established TBC shall be connected to the MBC even if the START message is not received.

### 10.5.1.5 Complementary connection bearer setup

A complementary connection setup shall always be REP initiated. A complementary connection allows to setup one duplex bearer without any interaction/notification with/to the higher layers, as explained in the following overview.

The calling side does not require the creation of a new MBC at the called side but can identify an existing MBC which the complementary connection can be referred to by activating a mapping procedure (see clause 10.5.1.6).

Called side:

- on the called side a new TBC is created by receiving a "REP\_bearer\_request" message, including the MAC addresses PMID and FMID on the scanned physical channel. The message type also contains the information that the new bearer belongs to a complementary connection.

MBC identification:

The TBC has to receive all necessary parameters to identify an MBC.

The MBC is fully identified after:

- a) receiving with "REP\_bearer\_request" message either a REP\_access request or a REP\_bearer\_handover request (see clause 7.2.5.11), including the calling address PMID and defining the connection type as complementary; and
- b) receiving the REP\_channel\_map\_request message (see clause 7.2.5.11) which indicates the duplex bearer to which the complementary connection setup bearer has to be linked. This message is necessary only for a new bearer setup; in case of a bearer handover request, the old mapping still stays effective. The MBC to refer to is the one to which belongs the TBC of the linked bearer.

The TBC issues a PMID, ARI and the REP\_channel\_map.request message, when received, to the referred MBC and indicates the purpose of the wanted connection (bearer handover or a new setup).

The MBC can now decide:

- a) to release the TBC;
- b) to accept the TBC.

Procedure description:

The procedure for a complementary connection bearer setup is identical to the basic bearer setup procedure as described in clause 10.5.1.1 and to the duplex bearer handover procedure as described in clause 10.6.2, in case of bearer handover, where:

- the PT is REP and the FT could also be a REP;
- the exchanged Mt messages belong to the REP control set (see clause 7.2.5.11);
- the bearer\_request message can be either a REP\_access.request or a REP\_bearer\_handover.request message.

### 10.5.1.6 Double duplex bearer setup procedure: Mapping procedure

The mapping procedure shall always be REP initiated. This procedure allows to set-up a double duplex bearer, after two duplex bearers have been setup between two far ends. When one of the two duplex bearers already belongs to a double duplex bearer the procedure is called "interlacing".

After receiving without errors the REP\_channel\_map.request message (see clause 7.2.5.11.3) onto a duplex bearer, the receiving side can decide:

- a) to Accept to map together the indicated channels;
- b) to Reject to map together the indicated channels.

NOTE 1: Receiving without errors means A-field CRC holds and message is recognized (message type decoded).

NOTE 2: Case (b) may apply when interlacing of the two duplex bearers is requested and the receiving side does not support "interlacing".

As soon as it is ready, the receiving side shall answer by sending onto the same duplex bearer the REP\_channel\_map.confirm message (see clause 7.2.5.11.4) with the A/R flag set to "Accepted", if it is case (a), otherwise to "Rejected".

After reception without errors of the REP\_channel\_map.confirm message with A/R flag set to "Accepted", the double duplex bearer is setup. After reception without errors of the REP\_channel\_map.confirm message with A/R flag set to Rejected, a new REP\_channel\_map.request message may be forwarded but selecting a more suitable duplex bearer (i.e. a duplex bearer which does not already belong to a double duplex bearer).

The REP\_channel\_map.request message may be repeated until the REP\_channel\_map.confirm message is detected or a connection release is recognized.

Within the double duplex bearer the two duplex bearers shall exchange their simplex bearers such that the information flow, for the uplink transmission direction, shall use the uplink simplex bearer of one duplex bearer and, for the downlink transmission direction, the downlink simplex bearer of the other duplex bearer. The figure at the end of this clause shows an example of information flow within a double duplex bearer.

The first SN and CN fields (bits  $a_{16}$  to  $a_{25}$ ) of the channel\_map.request message indicate the "Master channel": it is the channel controlled by that MBC which, after the mapping, will also control the other channel indicated by the following SN and CN fields (bits  $a_{38}$  to  $a_{47}$ ). In other words, after the mapping procedure has been successfully completed, the linked channels shall both belong to the master channel connection.

The release of one of the two duplex bearers composing the double duplex shall cancel the link, given with the mapping procedure, between the surviving duplex bearer and the released one.

The REP\_channel\_map.req message may over-ride the T-Mux algorithm (see clause 6.2.2.1) when transmitted as a first "other" message (see clause 10.5) during a bearer setup procedure. The first response (REP\_channel\_map.confirm message) shall occur in the TDMA half frame following the successful reception of the REP\_channel\_map.request from the receiving side and may also over-ride the T-Mux algorithm. The TBC shall report "bearer established" after the mapping procedure is successfully completed (i.e. the double duplex bearer has been setup).



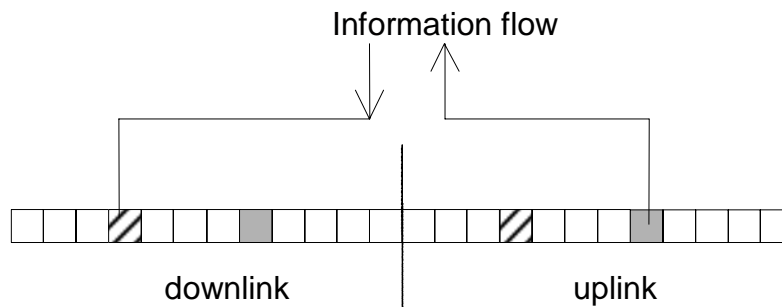

Figure 10.2

### 10.5.1.7 Usage of TA special code "111" and $M_T$ message "B-field setup, first PT transmission"

The special TA header code "111" (see clause 7.1.2) and the  $M_T$  message "B-field setup, first PT transmission" (see clause 7.2.5.8) are aids to the implementation in order to make possible that FT could be only listening to the beginning of the slots for idle bearers, and therefore reducing Rx power consumption. However their use is not strictly necessary, and there can be other technical solutions to achieve the same Rx power reduction objectives. In addition to that, the convenience of their use may depend on the application scenario.

The use of this implementation aids shall be as follows:

#### Usage of TA = "111" header

For applications covered by a DECT Application Profile, the Application Profile Specification may determine when TA code = "111" shall be used, instead of regular code TA "110". The code "111" shall always match with  $M_T$  channel in the A field tail.

For applications not covered by an application profile specification, or if the application profile does not mention any specific provision about the topic, the use of the TA code = "111" shall be as described in clause 10.5.1.7.1 (default rule).

#### Usage of $M_T$ message "B-field setup, first PT transmission"

This message can only be used in combination with the B-field message "Bearer request" (all types).

For applications covered by a DECT Application Profile, the Application Profile Specification may determine when the  $M_T$  message "B-field setup, first PT transmission" has to be inserted in A-field tail.

For applications not covered by an application profile specification, or if the application profile does not mention any specific provision about the topic, the insertion of the  $M_T$  message "B-field setup, first PT transmission" shall be as described in clause 10.5.1.7.2.

### 10.5.1.7.1 Default rules for TA code "111"

The following rules apply unless specific provisions are given in an application profile:

The use of the code applies to all types of setup:  $M_t$  Basic,  $M_t$  Advanced and B-field setup.

- TA code = "111" shall only be used by the PT exclusively in the initial message "Bearer.request" in the following procedures:
  - PT initiated initial duplex bearer setup. Initial duplex bearer setup can be either a call setup, a signalling operation (I.e. location update) or a resume operation (DPRS), an implies that there is no other bearer set in this FT-PT pair.
  - PT initiated additional duplex bearer setup (multibearer connections), only if the setup is *unexpected*. A setup is *unexpected* performed on the FT primary scan sequence without prior exchange of channel list START or LISTEN commands.

- The TA code ="111" shall not be used in case of double simplex bearer setup.

NOTE: Double simplex bearer setup is always *expected*.

- The TA code "111" shall never be used by the FT.
- The use of TA code "111" implies that the content of the A tail is  $M_T$  (MAC control) channel.

#### 10.5.1.7.2 Default rules for $M_T$ message "B-field setup, first transmission"

The following rules apply unless specific provisions are given in an application profile:

This  $M_T$  message shall be inserted in the A-field tail of the slot carrying the B-field message "Bearer request" (all types) only in the following cases:

- PT initiated initial duplex bearer setup. Initial duplex bearer setup can be either a call setup, a signalling operation (I.e. location update) or a resume operation (DPRS), and implies that there is no other bearer set in this FT-PT pair.
- PT initiated additional duplex bearer setup (multibearer connections), any case.
- Double simplex upstream bearer setup.

$M_t$  message shall only be used by the PT, and shall not be inserted by the FT in any case.

If this message has to be inserted (according to this rule, or to the rule described in an Application profile) it is allowed to violate the PT T-MUX sequence.

In order to insert this message, the TA header should be either TA=111 or TA="110". TA ="111" shall be used only when mandated by clause 10.5.1.7.2, or by an application profile. In all other cases, the TA code shall be "110".

#### 10.5.1.8 Expedited bearer setup procedures

The expedited bearer setup procedures are optimized advanced  $M_T$  setup procedures intended for ultra fast setup of bearers, allowing in most cases reduction in the number of messages and early U-plane transmission compared to regular procedures.

Expedited messages are only used for resume (bearer setup of existing MAC connections) or suspend (bearer release without clearing the connection at MBC level).

Expedited bearer setup procedures are only defined as PT initiated. However, once initiated by the PT, FT may change the continuation of the procedure.

Expedited messages may coexist with other advanced connection control set messages.

##### 10.5.1.8.1 General

The following expedited bearer setup messages are used to initiate the setup procedure:

- "Expedited bearer setup" (see clauses 7.2.5.12.1 and 7.2.5.12.2)
- "Expedited bearer setup ready for release" (see same clauses)

These messages are used in conjunction with the following possible response messages:

- "Bearer confirm" (from the advanced control set)
- "Ready for release" (see clauses 7.2.5.12.1 and 7.2.5.12.2)
- "Expedited Release" (see same clauses)

Two basic sequences of procedures exist:

- Single-burst bearer setup, where the initiating side attempts to transfer a single packet of data and immediately release the connection.
- Multi-burst bearer setup, where the initiating side attempts to set up a bearer for more than one frame.

Depending on the data available for transmission at both sides the procedure may evolve in different ways. For instance a procedure initiated as a Single-burst bearer setup may continue as a Multi-burst bearer setup.

### 10.5.1.8.2 Procedure for Single-burst setup and release

The Single-burst setup and release is an optimized procedure intended for the transmission of a single packet of U-plane of C-plane data from the initiating side (the PT) to the terminating side (the FT). The procedure allows for the transmission of a release reason and a  $G_{FA}$  channel message in the opposite direction.

#### 10.5.1.8.2.1 Procedure description

##### **Predicates:**

- a) PT is in frame and multiframe synchronism with a RFP. The PT has already learned the RFPI of at least one RFP within this cluster and knows the RFP's receiver scanning sequence;
- b) There is an existing MBC already created between the PT-FT pair and thus a MAC connection in suspended state. The connection has an ECN number compatible with expedited procedure;
- c) The PT has a single packet of data (or C-plane) to be transmitted upstream.

##### **Procedure description:**

This procedure is based on the exchange of two frames:

Frame 1 (transmitted PT to FT) with the following content:

- A-field header
  - $TA = M_T$
  - $BA = IP1$ , or in some cases no-B-field or E-mux
- $M_T$ : message "Expedited Access Request Ready for Release"
- B-field: the IP segment (U-plane) ready for transmission. Exceptionally, no B-field or an E-mux message

Frame 1 (transmitted FT to PT) with the following content:

- A-field header
  - $TA = M_T$
  - $BA = \text{no-B-field}$
- $M_T$ : message "Expedited Release"
  - Reason code and info: any valid value
  - $G_{FA}$ : last valid ACK RN
- B-field: no-B-field

### 10.5.1.8.2.2 Handling of error cases

- 1) In case of no reception of any response message with valid A-field CRC in the frame 1 FT => PT, the response from the PT should be the following:
  - No action. No further messages shall be sent and the TBC shall be silently released.
  - The U-plane packet shall be considered as not transmitted. The MBC may re-attempt its transmission over a separate TBC within the time given by the maximum MAC packet lifetime.
- 2) In case of reception of the expected "Release" message with valid A-field CRC, but with Q2 bit indicating bad reception of the B-field in the frame 1 FT => PT, the response from the PT should be the following:
  - No action. No further messages shall be sent and the TBC shall be silently released;
  - The U-plane packet shall be considered as not transmitted. The MBC may re-attempt its transmission over a separate TBC within the time given by the maximum MAC packet lifetime.

### 10.5.1.8.2.3 Change to Multi burst bearer setup procedure

This procedure may be changed by the FT to a multi burst data transfer by replying with "bearer confirm" or "ready for release".

- 1) In case of reception of the messages "Bearer Confirm" or "Ready or Release", the procedure shall continue as mandated for the "Multi burst bearer setup procedure" as indicated in clause 10.5.1.8.3. Table 10.1 of clause 10.5.1.8.3.3 contains the possible use cases for the transition.

### 10.5.1.8.3 Procedure for Multi burst setup

The Multi burst setup procedure is an optimized procedure intended for the transmission of a burst of several U-plane data or C-plane packets from the initiating side (the PT) to the terminating side (the FT). The procedure allows for the transmission of a release reason and at least one  $G_{FA}$  message in the same and in the opposite direction.

#### 10.5.1.8.3.1 Procedure description

##### **Predicates:**

- a) PT is in frame and multiframe synchronism with a RFP. The PT has already learned the RFPI of at least one RFP within this cluster and knows the RFP's receiver scanning sequence;
- b) There is an existing MBC already created between the PT-FT pair and thus a MAC connection in suspended state. The connection has an ECN number compatible with expedited procedure;
- c) The PT has a multi burst of data (or C-plane) to be transmitted upstream.

##### **Procedure description:**

This procedure is based on the exchange of the following frames and messages:

Frame 1 (2<sup>nd</sup> half frame) transmitted PT to FT with the following content:

- A-field header:
  - $TA = M_T$
  - $BA = IP1$ , or in some cases no-B-field or E-mux
- $M_T$ : message "Expedited Access Request"
- B-field: the IP segment (U-plane) ready for transmission. Exceptionally, no B-field or an E-mux message

Frame 2 (1<sup>st</sup> half frame) transmitted FT to PT with the following content:

- A-field header:
  - TA = M<sub>T</sub>
  - BA = IP1, no-B-field or E-mux
- M<sub>T</sub> : message: any of the following:
  - "Bearer Confirm"
  - "Ready for release", in this case:
    - Reason code and info: any valid value
    - G<sub>FA</sub>: last valid ACK RN
- B-field: an IP segment (U-plane) ready for transmission, no-B-field or an E-mux packet

Frame 2 (2<sup>nd</sup> half frame) transmitted PT to FT:

This frame shall contain one of the following:

- Any message (including Null or N<sub>T</sub>) together with U-plane data (or C-plane data) if the received message was "Bearer Confirm" and the PT has data (U-plane or C-plane) to be transmitted upstream.
- The M<sub>T</sub> message "Ready for Release" together with U-plane data (or C-plane data) if the received message was "Bearer Confirm" or "Ready for Release" and the PT has only one packet of data (U-plane or C-plane) to be transmitted upstream.
- The M<sub>T</sub> message "Ready for Release" together with "no-B-field" if the received message was "Bearer Confirm" or "Ready for Release" and the PT has no data (U-plane or C-plane) to be transmitted upstream.

NOTE 1: In the last two cases, a G<sub>FA</sub> message may be included in the "Ready for Release".

NOTE 2: In the last two cases, the next transmission FT => PT may continue the transmission of U-plane or C-plane data, or may contain an "Expedited Release" message, initiating a General Expedited release procedure as described in clause 10.7.3.2).

#### 10.5.1.8.3.2 Modification Single-burst setup => Multi-burst setup

A procedure initiated as a Single-burst setup by the PT may be modified by the FT to be a Multi-burst setup. The next clause 10.5.1.8.3.3 shows the possible combinations of response messages and execution paths.

#### 10.5.1.8.3.3 FT Response table

The following table shows what the FT is to respond with, dependent on the received First PT Transmission message, and how many packets the FT has to send to the PT.

**Table 10.1: Expedited setup procedures execution table**

|                                                                                                                                                        |    | Received First PT Message                              |                                      |
|--------------------------------------------------------------------------------------------------------------------------------------------------------|----|--------------------------------------------------------|--------------------------------------|
|                                                                                                                                                        |    | Expedited_access_request_ready_for_release<br>(note 1) | Expedited_access_request<br>(note 2) |
| Packets to be<br>send by the FT                                                                                                                        | 0  | expedited_release                                      | ready_for_release (BA=no B-field)    |
|                                                                                                                                                        | 1  | ready_for_release (BA=IP1)                             | ready_for_release (BA=IP1)           |
|                                                                                                                                                        | >1 | bearer_confirm                                         | bearer_confirm                       |
| NOTE 1: "Expedited_access_request_ready_for_release" may be sent with BA=IP1 or with 'no-B-field'.                                                     |    |                                                        |                                      |
| NOTE 2: "Expedited_access_request" may carry U-plane (BA=IP1), E-mux (typically C <sub>F</sub> channel, when supported), or in some cases, no B-field. |    |                                                        |                                      |

#### 10.5.1.8.4 Announcement "Ready for Release"

The message "Ready for Release" is used to indicate to the other side that there is no more data (U-plane or C-plane) to be transmitted. A last segment of U-plane or E-mux data may be optionally be sent together with the "Ready for Release". It is allowed to send also "no-B-field".

The message "Ready for Release" may include the transmission of a G<sub>FA</sub> channel ACK command.

"Ready for Release" may be sent in any direction (PT => FT or FT => PT).

After receiving the message "Ready for Release" the other peer may choose between continuing the transmission of either U-plane segments or E-mux data (if they exist) sending an "Expedited Release", or initiating an Expedited Release procedure (as described in clause 10.7.3.2).

- In the first case, the peer that continues the transmission will be in charge of sending a "Ready for Release" when the data to be transmitted (either U-plane or C-plane) ends.
- In the last case, the peer that is going to initiate the Expedited Release procedure, should have been sent previously a "Ready for Release" message or should have initiated the setup using an "Expedited Access Request Ready for Release".

The sending of "Ready for Release" when there is no data for transmission (either U-plane or C-plane) is mandatory. The exact rule for what is understood as "no data for transmission" and when the message has to be sent, will be provided by each specific application profile under the Management Entity section. Such rules may include timers and tolerances.

NOTE 1: Such rules may include timers and tolerances.

NOTE 2: For DECT ULE, see TS 102 939-1[i.10], clause 9.

##### 10.5.1.8.4.1 Protection of the message "Ready for Release"

The following rule shall be used to ensure the correct reception of "Ready for Release" message:

- After transmission of the "Ready for Release", the sending side should receive in the next half-frame confirmation of correct reception of at least the A-field, by means of the Q1/Q2/BCK bits. If this is not the case, the sending side shall repeat the transmission of the "Ready for Release" message.

NOTE 1: The possible setting and valid coding of the quality bits depends on the MAC service and B-field mode (BA bits) used in the transmitted frame. For the usual case of MAC service I<sub>p</sub> error correct and E/U-mux set to U-mode packet, the bit Q2 is the relevant one; Q2="0" should cause a retransmission.

NOTE 2: Error in the reception of the half-frame that is expected to carry the quality bits (bad A-field CRC), should also cause a retransmission.

It is not required, in general, the repetition of the message "Ready for Release" after receiving confirmation of its correct reception. Refer to the applicable Application Profile for exact description of the use case sequences.

#### 10.5.1.8.5 Indirect FT initiated expedited bearer setup procedure

FT initiated expedited setup procedure may only be triggered by using B-field paging (indirect procedure). Typically, but not necessarily, B-field paging is used (for instance in ULE, see TS 102 939-1 [i.10]). The PT replies to the paging request executing a PT initiated expedited setup procedure as described in previous clauses.

The following conventions shall be followed by the PT when the expedited setup procedure is executed as response to a FT paging request:

- 1) If the PT has no data (U-plane or C-plane) to be sent upstream, it will initiate the procedure using the  $M_T$  "Expedited Access Request Ready for release" message and BA code = "no B-field";
- 2) If the PT has only one packet of data (U-plane) to be sent upstream, it will initiate the procedure using the  $M_T$  "Expedited Access Request Ready for release" message and BA code = "IP1";
- 3) If the PT has more than one packet (U-plane or C-plane) to be sent upstream, it will initiate the procedure using the  $M_T$  "Expedited Access Request" message;
- 4) In general, the FT will continue the procedure sending "Bearer Confirm" or "Ready for Release" together with an U-plane packet;
  - If only a single packet was to be sent downstream, the FT reply is "Ready for Release"; if several packets are ready to be send, then "Bearer Confirm".
- 5) An FT response "Expedited Release" is possible if the indirect setup request was only due to a MAC handshake (stay alive) procedure.

#### 10.5.1.8.6 Insertion of U-plane in "Expedited access request" messages

In expedited setup procedures, the U-plane transmission may start in the very first frame, over the B-field of the same physical packet that is carrying the  $M_T$  Access Request message.

When  $I_p$  error correct is used, the IP number 1 shall be used for this packet, and coded in the BA bits.

#### 10.5.1.8.7 Connected state (TBC) in expedited bearer setup

Connections using expedited procedures are normally packet mode connections which are permanently or semi-permanently in connected state at MBC level (at least during the duration of the Virtual Call). However from the point of view of the TBC, the connection is considered "TBC connected" at the following points:

- The initiating side (which is always the PT) changes the TBC state to "connected" after correct reception of the response to the setup message, provided that:
  - If the initial message was  $M_T$  "Expedited Access Request", if the response message is not "Release" (it may be either "bearer confirm" or "Ready for Release").
  - If the initial message was "Expedited Access Request Ready for Release", only if the response message is "bearer confirm".
- The FT changes the TBC state to "connected" after correct reception of the second frame transmitted by the PT (the third frame of the sequence), provided that it carries any A-field content except the following:
  - $M_T$  message "Expedited Access Request" or "Expedited Access Request Ready for Release" (repetition of the setup attempt); in such a case it will restart the counting and will look for a second message in the following frame that qualifies for the rule.
  - $M_T$  message "Expedited Release"; in such a case this TBC should never reach the "connected" state.

NOTE 1: Any other content (including  $N_T$ ,  $M_T$  'Null' or any other channel) qualifies for the rule.

The TBC "connected" or "not connected" state has influence in the response upon errors in transmission.

NOTE 2: It should be noted that, for instance, a single burst connection never reaches the "connected" state.

#### 10.5.1.8.8 Encryption synchronization in expedited bearer setup

When MAC encryption is used, the encryption or not encryption of the connection after an expedited bearer setup shall be set as before last suspension, without the need of any further signalling process.

The point of activation of the encryption after the setup shall follow the general DECT rules:

- In absence of errors, the third frame transmitted by any side shall be the first encrypted.
- In case of errors in the reception of the first message (access request), the initiating side shall switch on the encryption two frames after receiving the correct response to the access request (that may be either "bearer confirm" or "ready for release").
  - In other words, it will reset the counting with any repetition of the "Access Request" message.
- The other peer shall switch on the encryption two frames after sending the response to the "Access Request" message.
  - In the event of receiving repeated "Access Request" messages, it will start the counting with the response sent to the last of these messages.

When the MAC encryption is switched on, it will encrypt B-field (any content) and also  $C_T$  messages in the A-field. The synchronization point is the same.

NOTE 1: Note that a single burst transmission will never reach the MAC encrypted state.

NOTE 2: This clause refers to the MAC encryption using the KSG. The CCM encryption (when used) is not impacted by the rule and is, in general, active from the beginning.

#### 10.5.1.8.9 Use of short slots in expedited connections

In expedited connections, in order to further save energy, it is allowed to transmit as short slots frames that do not carry any B-field in certain cases. This is only allowed in the cases listed in this clause. The use of short slots is optional at sending side (transmitter choice). However its understanding by the receiving side is mandatory.

By "short slot", it is meant a physical packet P00 with the D-field mapping as defined in clause 6.2.1.1.3.

The following rules shall apply:

- 1) Only frames with BA coding "no-B field" may be transmitted as short slots.
- 2) Frame containing an "Expedited Access Request Ready for Release" message may be transmitted as a short slot when it contains no B-field.
- 3) Frame containing a "Ready for Release" message may be transmitted as a short slot when it contains no B-field.
- 4) After sending a "Ready for Release", either using full slot (regular rule) or short slot (as result of previous rule), the peer may use a short slot in the next frame or may switch to short slot at any time.
- 5) Frame containing "Expedited Release" messages may always use short slots.
- 6) Usage of short slots in one and in the other direction is independent.

NOTE: The application profiles may introduce additional restrictions.



## 10.5.2 Channel list procedures

### 10.5.2.1 General

The channel list messages are used to reduce the establishment time of multibearer connections by negotiating changes to the receiver scanning patterns at the receiving side. Moreover, a complete set of channels can be selected at the start of the connection establishment procedure using the channel selection rules.

For duplex bearers (symmetric or asymmetric connections):

- Channel list messages should be used if service is bursty (such a packet mode service). As a matter of fact, the update of the channel selection list and the update of the blind slot information are not done in real time in the PP, so the FP has a better view of the channels used.
- The channel list messages GOOD, LISTEN or POOR may be used to improve the success and response time of the procedure. The LISTEN command indicates that the sending side has activated a receiver in the channel/slot indicated, and allows the PT to perform a setup on such specific slot/channel, even if this is not in the FT or PT scan sequence. This command is typically sent by the FT in case of PT initiated setup. The GOOD message does not modify the PT or FT receiver scan sequence, but the indicated channels may be used for a new bearer even if they are marked as "busy" in the channel list. The POOR command indicates that the indicated channels cannot be used.
- The START command can be used by the initiating side to announce a setup in a different channel of the other peer receiver scan sequence. This command may be sent by the FT on an existing bearer in case of FT initiated setup of additional duplex bearers.

For double simplex bearers (asymmetric connections):

- Channel list messages shall be used. In addition to the previous reasons, asymmetric services may cause more disturbance on the timeslots.
- The channel list commands LISTEN or START (at least one of them) plus the command ACTIVE are mandatory in double simplex bearers setup.
- The START message send by the T-side on an pre-existing bearer, announces double simplex bearer setup and indicates to the receiver that it shall listen all slots/channels indicated in the message(s).
- The LISTEN message send by the R-side on an pre-existing bearer, indicates to the T-side that the R-side has activated a receiver on the slots/channels indicated in the message(s), and that the T-side may initiate a double simplex bearer setup on them.
- The GOOD command send by the R-side indicates candidate slot/channels, however it does not indicate that the R-side has activated a receiver on them. The T-side has to confirm, sending a START command, that is going to use these channels.
- The ACTIVE message is used to acknowledge and confirm the setup of double simplex bearers.

### 10.5.2.2 Description of the channel list messages

| Message  | Meaning                                                                                                                                                                                        |
|----------|------------------------------------------------------------------------------------------------------------------------------------------------------------------------------------------------|
| ACTIVE:  | The endpoint that sends this message reports that the indicated pair of physical channels is in use as an established bearer of this connection.                                               |
| GOOD:    | The indicated pair of physical channels is unused at the endpoint that sends this message, and may be used for a new bearer.                                                                   |
| POOR:    | The endpoint that sends this message tells the recipient that the indicated pair of physical channels cannot be used for a new bearer, e.g. poor quality or already in use with a third party. |
| F/S_NOT: | The endpoint that sends this message does either not support the indicated frequency or has a "blind slot" at the indicated slot position (see coding in clause 7.2.5.3.10).                   |

- QUERY\_N:** The endpoint that sends this message requests some information on the indicated pair of physical channels.
- QUERY\_H:** The QUERY\_H channel list message has exactly the same function as the QUERY\_N message. The QUERY\_H message however shall only be used to get channel information needed for bearer handover and for connection handover.
- LISTEN:** The endpoint that sends this message reports that its receiver temporarily installs a "receive only" TBC which will listen to the receive channels of the indicated pair of physical channels for at least the next 4 TDMA frames in order to recognize bearer setup requests.
- START:** The endpoint that sends this message has selected the indicated pair of physical channels for a new bearer and shall transmit on this bearer in at least the next TDMA frame. If the channel pair is accessible and no TBC is installed at the receiving endpoint of a START message, the receiving side should install a temporary "receive only" TBC to recognize bearer setup requests.

### 10.5.2.3 Usage of the channel list messages

- | <b>Message</b>  | <b>Meaning</b>                                                                                                                                                                                                                                                                                                                                                                                                                                                                                                                                                                                                                                                                                                                        |
|-----------------|---------------------------------------------------------------------------------------------------------------------------------------------------------------------------------------------------------------------------------------------------------------------------------------------------------------------------------------------------------------------------------------------------------------------------------------------------------------------------------------------------------------------------------------------------------------------------------------------------------------------------------------------------------------------------------------------------------------------------------------|
| <b>ACTIVE:</b>  | <p>This message shall be used by the receiving side to confirm the establishment of a double simplex bearer, and may be used from either side at any time to report the status of the physical channel pair.</p> <p>This message may be also used to trigger encryption of double simplex bearers, instead of the START (see clause 10.5.1.4.7.2, "Synchronization at ACTIVE").</p>                                                                                                                                                                                                                                                                                                                                                   |
| <b>F/S_NOT:</b> | These messages may be used at any time from either side to report the status of the physical channel pair.                                                                                                                                                                                                                                                                                                                                                                                                                                                                                                                                                                                                                            |
| <b>QUERY_N:</b> | This message may be used at any time from either side.                                                                                                                                                                                                                                                                                                                                                                                                                                                                                                                                                                                                                                                                                |
| <b>QUERY_H:</b> | This message is allowed only during a handover operation (bearer or connection).                                                                                                                                                                                                                                                                                                                                                                                                                                                                                                                                                                                                                                                      |
| <b>LISTEN:</b>  | <p>This message is used to announce that the sending side is ready to accept a double simplex bearer setup attempt (handover or initial setup) on the indicated channel pair. For one setup attempt the LISTEN channel list message shall be sent on one or more bearers within one TDMA frame. The LISTEN channel list message, when used, is sent by the FT when the bearer belongs to an asymmetric uplink connection, and by the PT when the connection is asymmetric downlink.</p> <p>The LISTEN message may also be used to announce that the sending side is ready to accept a duplex bearer setup attempt (handover or initial setup) on the indicated channel pairs, even if they are not in the receiver scan sequence.</p> |

PTs may use this mechanism only when the connection is asymmetric downlink. FTs may use it.

- START:** This message is used to announce double simplex bearer setup attempts (handover or initial setup) on the indicated channel pair and, optionally, to trigger encryption on those bearers (see clause 10.5.1.4.7.1 "Synchronization at START"). For one setup attempt the START channel list message shall be sent on one or more bearers within one TDMA frame. The START channel list message, when used, is sent by the PT when the bearer belongs to an asymmetric uplink connection, and by the FT when the connection is asymmetric downlink. The START message may also be used to announce duplex bearer setup attempts on channels other than the scanned channels (see clauses 11.8 and 11.9). When used, the message is sent on one or more bearers within one single TDMA frame. FTs may use this mechanism only when the connection is asymmetric downlink. PTs may use it when the connection is symmetric or asymmetric uplink connection. Except for the START message, all channel list messages may be retransmitted. When not explicitly prohibited, the channel list messages can be sent on any bearer of the connection, even during bearer setup (if the capacity is available).

when the connection is symmetric or asymmetric uplink connection.

**NOTE 1:** Either the LISTEN or the START command may be used to initiate a double simplex bearer setup.

NOTE 2: Clauses 10.2.4.3.1 to 10.2.4.3.3 describe which endpoint is allowed to initiate bearer setup. Therefore, a LISTEN message transmitted in the wrong direction is meaningless.

NOTE 3: There is no guarantee the receiving endpoint will decode the channel list messages during bearer setup. It is recommended to transmit important messages which may influence setup procedures (i.e. LISTEN, START, and ACTIVE) only on established bearers.

The following channel list messages should produce a response from the receiving entity:

- QUERY\_N or QUERY\_H messages:
  - Message responses shall be: GOOD, POOR, ACTIVE, LISTEN or F/S\_NOT.
- START message for double simplex bearer:
  - Message response shall be: ACTIVE or POOR.

## 10.6 C/O bearer handover

### 10.6.1 General

The MAC layer provides PTs and FTs with several mechanisms to control the quality of transmissions and receptions. Bearer handover may be initiated either by using this quality information or by receiving a bearer handover request message from the far end (see clauses 7.2.5.5 and 7.2.5). For duplex bearers the PT only can initiate a bearer handover, and for double simplex bearers the transmitting side only can initiate a bearer handover. The existing bearer can be maintained until the new bearer has been established. During bearer handover the two bearers can operate in parallel.

NOTE 1: Bearer handover requires that an MBC for the connection exists on both sides, PT and FT, and that the new selected RFP at the fixed side belongs to the same cluster.

PTs should use bearer handover to attempt to connect to the best RFP of the cluster in which the connection is established. This may be the same RFP as the existing bearer, or may be a new RFP.

DECT equipments may have several indicators to monitor reception quality:

- the A-field CRC;
- the X-field CRC;
- the CRCs of the B-subfields in protected mode (E-type or U-type for  $I_p$ );
- X-field to Z-field comparison (for Z-field refer to EN 300 175-2 [2]);
- link identity information;
- synchronization pulse;
- clock jitter;
- signal strength;
- etc.

To control the quality of transmissions the MAC layer uses the reports from the far end, coded in two bits:

- the (Q1,Q2) bits; or
- the (BCK,Q2) bits (see clauses 7.1.1 and 7.3.4.4).

There are no specified rules for the PT which define when a bearer handover attempt has to be made. For system reasons the maximum rate at which bearer handovers can be performed is limited by a simple timer. No more than two successful bearer handovers should occur within T202 seconds.

NOTE 2: This should not be confused with multiple attempts for one handover.

NOTE 3: For bearer handover (both intra- and inter-cell) in multibearer connections, each bearer is treated separately.

Different handover procedures exist for duplex and double simplex bearers.

## 10.6.2 Duplex bearer handover procedure

The setup of a new bearer for duplex bearer handover is always initiated by the PT. The MBC of the PT shall have knowledge of at least one available channel and shall know the address (FMID) of the wanted FT. The MBC creates a TBC and issues called address (PMID/FMID) and the physical channel description to the new TBC. The MBC indicates to the TBC that the wanted bearer is used for a bearer handover and which bearer setup procedure shall be used. In addition, for advanced connections the MBC issues the new TBC with the ECN and the LBN, which is also assigned to the TBC of the bearer which has to be handed over.

The TBC tries to set-up a new bearer using one of the single bearer setup procedures described in clause 10.5.1:

- the basic bearer setup procedure for all basic connections;
- the A-field single bearer setup procedure or the B-field single bearer setup procedure for advanced connections.

At the end of all these procedures the TBC reports either "bearer\_established" or "bearer\_setup\_failed" to the MBC.

NOTE 1: At the called side these messages only occur if a bearer setup attempt was detected (TBC created).

If the bearer setup failed the MBC can reattempt a bearer handover with the same procedure, subject to using a new available channel each time (see clause 11.4) and/or accessing a new RFP. Within any time window of T202 seconds at most N201 bearer setup reattempts shall occur for a bearer handover of one particular bearer.

An MBC assumes that a bearer setup was successful when the TBC reported "bearer\_established". Immediately after this TBC report the MAC switches the new bearer to the same E/U multiplex as used by the old bearer. For U-type databursts all following transmissions shall contain valid I channel data.

NOTE 2: In advanced connections the "new" and the "old" bearers have the same LBN number.

In basic connections, two bearers shall only occur during bearer handover. There is no LBN, i.e. the "new" and the "old" bearer are the only bearers of the connection.

For a limited time the MBC may maintain both TBCs, controlling the new and the old bearer. The MBC in the FT decides when and which one of the two TBCs is released with a bearer release procedure. The FT shall invoke this bearer release procedure within a time interval of T203 after the new bearer was established (TBC reported "bearer\_established").

NOTE 3: During the time where the new and the old bearer are maintained, both bearers together form one logical bearer (see clause 5.5.2).

For the limited time where both bearers are established:

Except for  $I_{N\_minimum\_delay}$  services all I channel data transmitted in one TDMA half frame is the same for both bearers (see data flow control, clause 8.4).

For  $I_{N\_minimum\_delay}$  services I channel data transmitted in one TDMA frame may be different for both bearers (see clause 8.4).

NOTE 4: For protected data connections the preferred procedure to delete an old bearer and setup a new one is the Bearer Replacement procedure (see clause 10.6.4).

## 10.6.3 Double simplex bearer handover

Although the double simplex bearer handover procedure is initiated by the transmitting endpoint (T-side), the receiving endpoint of a specific double simplex bearer may request a bearer handover. The request may be transmitted on any bearer in reverse direction. The request message is defined as an  $M_T$  message in clause 7.2.5.5 and as an extended MAC control message in clause 7.3.4.

By receiving a request to initiate a bearer handover procedure the transmitting side of a double simplex bearer may either initialize a bearer handover, reject the handover request with a BEARER\_HANDOVER\_REJECT message (see clauses 7.2.5.5 and 7.3.4) or not react upon this request message.

Initialization of a bearer handover starts with the negotiation of a new pair of physical channels. This is done using the channel list procedures. The new bearer is set-up with the double simplex setup procedure (see clause 10.5.1.4), except that the UNCONFIRMED\_HANDOVER message is used in place of the UNCONFIRMED\_ACCESS\_REQUEST message. The same logical bearer number LBN is assigned to the new double simplex bearer as for the old bearer.

As soon as possible all I channel information carried on this logical bearer is duplicated on both double simplex bearers.

This occurs no later than when the bearer is established, i.e. when the transmitting side end receives the ACTIVE message (see channel list procedure).

Within any time window of T202 seconds at most N201 double simplex bearer setup re-attempts shall occur for a bearer handover of one particular double simplex bearer.

NOTE: The relevant reattempts are those where the initiating side actually starts transmissions on a new bearer.

The new bearer setup is successful when the initiating side receives a confirmation, i.e. an ACTIVE message (see clauses 7.2.5.3.10 and 7.3.2.7) for this bearer. As soon as this message is received the initiating side proceeds with a bearer release of the old double simplex bearer with the unacknowledged release procedure (see clause 10.7.2.1).

## 10.6.4 Bearer replacement

### 10.6.4.1 General bearer replacement

This procedure is one way to improve the quality of a connection by changing bearers to different channels within the same cluster.

"Bearer replacement" is defined to be the procedure where an old bearer is replaced with a new bearer that has a different LBN or where the old bearer was lost before the new bearer is setup with the same LBN. The procedure to setup the new bearer is defined by clause 10.5. The procedure to release the old bearer is defined in clause 10.7.

For replacement of one bearer of an Ip\_error\_correct connection the procedure is defined in clause 10.8.2.5.1.

It is preferred to first drop the old bearer and then set-up the new bearer, or to do this simultaneously. It is not required to have the new bearer active before the old bearer is released.

NOTE: For multibearer packet mode data connections, and for all bearers except the last duplex bearer, it is recommended to execute the bearer replacement procedure dropping first the old bearer and then setting-up the new one.

### 10.6.4.2 Frequency replacement

"Frequency Replacement" is defined as a case of bearer replacement procedure where an old bearer is replaced with a new bearer which is located on the same time slot pair but uses a different frequency.

The procedure shall only apply if a different time slot pair cannot be found before the bearer would be released.

The selection of the new frequency shall be done in accordance with the channel selection rules as described in clause 11.4. This requires stopping the reception of the affected channel for a frame in order to perform the required RSSI measurements on the new frequency.

The frequency replacement procedure shall always be PT initiated and applies either to duplex or to double simplex bearers.

**Procedure description:****Frequency Replacement for a Duplex Bearer**

The PT side:

- The PT shall send the frequency replacement request message to the peer entity with the indication of the new bearer to be setup (see clauses 7.2.5.5 and 7.3.4.2).
- This quality control message shall be sent on one duplex bearer of the connection which could be the affected one.
- In the frame after the transmission of the frequency replacement request message, the PT shall switch reception from the old to the new bearer and try to receive the frequency replacement confirm message (see clauses 7.2.5.5 and 7.3.4.2) on that bearer. If a confirm message is not detected, the request message can be repeated up to N206 times or until the old bearer is released.
- If, after N206 attempts, the confirm message is not received the PT shall release the old bearer and the new bearer. Otherwise, if a confirm message is received, in the same frame the PT shall switch transmission from the old bearer to the new bearer and send the frequency replacement grant message (see clauses 7.2.5.5 and 7.3.4.2) on that bearer. The frequency replacement grant message can be repeated up to N207 times or until the new bearer is released.

The FT side:

- Upon reception of a frequency replacement request message, the FT shall switch the transmission and reception from the old to the new bearer and send the frequency replacement confirm message on that bearer. The confirm message can be repeated up to N207 times until a frequency replacement grant message is detected or until the new bearer is released. If, after N207 attempts, the grant message is not received the FT shall release the new bearer.

**Frequency Replacement for a Double Simplex Bearer**

The same procedure as for the duplex bearer applies with the following exceptions.

The relevant MAC messages shall all be exchanged on one duplex bearer of the connection. The FT shall switch transmission and reception from the old bearer to the new bearer in the frame after the confirm message has been sent. The PT shall switch transmission and reception from the old to the new bearer in the frame where the grant message is sent.

The frequency replacement request, confirm and grant messages can be duplicated, when possible, in all the Bn sub-fields of the time slot (see clause 7.3) in order to improve the probability that the message is recognized (message type decoded and related CRC correct) by the peer entity.

The frequency replacement request, confirm and grant messages can overrule the T-MUX algorithm (see clause 6.2.2) when sent as Mt messages.

Frequency replacement grant messages received after the first one should be ignored.

## 10.7 C/O bearer release

### 10.7.1 General

Bearer release describes the release of a TBC which controlled a duplex or a double simplex bearer.

A bearer release may be caused by several events:

- a) the MBC on either side initiates a bearer release;
- b) a bearer in setup phase cannot be connected to an MBC. Here the LLME initiates a bearer release (see single bearer setup procedures);
- c) a TBC received faulty MAC messages during setup (see setup procedures);
- d) the TBC releases the bearer due to a timeout. See handshaking requirement (see clause 11.5);
- e) the TBC receives a release message error free.

NOTE 1: Event b) should not occur for double simplex bearers. Here the channels have to be negotiated before transmissions on a double simplex bearer start.

A bearer release is initiated when on either side one of the events a), b), c) and d) occurs. The FP shall only release a bearer if it has previously received a MAC control message referencing that bearer with correct FMID and PMID. Two bearer release procedures exist:

- the unacknowledged bearer release procedure; and
- the acknowledged bearer release procedure.

The unacknowledged bearer release procedure is always applied for a release of a duplex bearer, and for a double simplex bearer only if the MBC on the transmitting side decides to release the bearer. During this procedure MAC RELEASE messages (see clause 7.2.5.3.13) are transmitted and afterwards the TBC stops transmitting. As a consequence, one of the events d) or e) will occur at the far end.

NOTE 2: If event d) is recognized at the far end a second bearer release procedure is initiated.

The acknowledged bearer release procedure is applied when the receiving end of a double simplex bearer decides to release this bearer (events a), c) and d)). The release is negotiated on a duplex bearer.

NOTE 3: A connection release may interrupt this procedure.

### 10.7.2 Bearer release procedure description

#### 10.7.2.1 Unacknowledged release procedure

The unacknowledged release procedure shall be applied to release duplex bearers, and double simplex bearers only by the transmitting side (exception for double simplex bearer, see clause 10.7.2.3).

The unacknowledged release procedure uses the RELEASE message. This message allows the reason for a bearer release to be reported (only for advanced connections).

All sets of MAC connection control messages contain a RELEASE message. The unacknowledged bearer release procedure shall use the RELEASE message of that message set which was used to setup the bearer. If this message is transmitted in the B-field, the message may be duplicated into all subfields.

The RELEASE message appears twice without any warning, replacing the normal transmission. The message is sent two times in successive frames on that bearer which has to be released, and the transmitting end releases the radio channel immediately afterwards. If the TBC is connected to an MBC and it was not the MBC's decision to release the bearer, the TBC reports this event to the MBC and indicates the reason. Finally the MAC releases the TBC.

The receiving end shall release the bearer immediately after successful receipt of any RELEASE message. If the TBC is connected to an MBC the TBC shall report this event to the MBC and indicate the reason. The MBC shall release the TBC afterwards.

#### 10.7.2.1.1 Crossed bearer release procedure

The crossed bearer release is a specific case of the Unacknowledged release procedure that happens when the two sides of a duplex bearer try to execute the procedure at the same time.

In some data profiles (DPRS), this could happen quite often since the decision to release bearers has been communicated previously between both sides by means of a bandwidth negotiation.

This case is handled in the following way:

- If any DECT peer is executing an unacknowledged release procedure and receives a RELEASE message from the other peer indicating that is performing the same procedure, the first peer can consider the procedure completed without the transmission of the second RELEASE message.
- A DECT peer that is going to initiate a bearer release procedure –but has not send any RELEASE message yet- receives a RELEASE message from the other side, is allowed to send in the next half-frame its RELEASE message, and consider the procedure completed.

NOTE: In other words; when there is crossing of RELEASE messages, it is not needed the repetition of the message.

#### 10.7.2.2 Acknowledged release procedure

The acknowledged release procedure is only used to release double simplex bearers when initiated by the receiving end.

NOTE: The receiving end of double simplex bearers may only initiate an acknowledged release of any of these bearers when at least one established duplex bearer exists. Otherwise the TBC is released without any negotiation.

The receiving end of a double simplex bearer may request a release of this bearer by sending a RELEASE message on any bearer in reverse direction. Within this message the setting of the LBN shall identify the double simplex bearer, and whenever necessary the reason shall be set.

During bearer handover it is possible that the receiving end initiates an acknowledged bearer release either for the "new" bearer or for the "old" bearer due to a timeout. To avoid ambiguity the reason shall be set to "bearer handover successfully completed" or to "bearer handover failed". The first command means to release the "old" bearer the latter command indicates to release the "new" bearer.

If the transmitting end of an established double simplex bearer receives a RELEASE message for this bearer, it shall proceed with an unacknowledged bearer release.

The receiving end of a double simplex bearer may correctly receive a RELEASE command issued during the unacknowledged release procedure. In this case the bearer release is confirmed, the MAC releases the TBC and the procedure stops. If no release command is received within T213 frames after initiating the procedure the receiving end of the double simplex bearer shall use the channel list procedure to verify the channel status. The transmitting end may reply with a GOOD or a POOR message. These two messages indicate that the bearer is released. The MAC releases the TBC and the procedure stops. If the reply is the ACTIVE message the release procedure shall be repeated.

#### 10.7.2.3 Fast release procedure

The fast release procedure allows to switch the transmission direction of double simplex bearers very quickly.

The fast release procedure shall only be used during connection modification (see clause 10.3) to release double simplex bearers. The procedure is always initiated by the MBC of the transmitting side and uses the RELEASE message with the reason set to "reverse".

Both sets of advanced MAC connection control messages, A-field and B-field, contain this RELEASE message. The fast release procedure shall use the RELEASE message of that message set which was used to setup the bearer. If this message is transmitted in the B-field, the message may be duplicated into all subfields.



The RELEASE message appears in one TDMA frame on both physical channels of the double simplex bearer. The transmitting end releases the radio channel immediately afterwards and starts to scan on both radio channels for at least 4 TDMA frames. Within these 4 frames the "old" receiving side is now allowed to setup directly a double simplex bearer in the reverse direction.

The receiving TBC of a RELEASE message with the reason set to "reverse" shall report this event to the MBC. The MBC shall decide either to release the TBC or to setup a new double simplex bearer in reverse direction. Receiving a RELEASE message with reason set to "reverse" has the same effect as a normal release and a received LISTEN channel list message for this physical channel pair. To setup a new double simplex bearer the MBC proceeds with the double simplex setup procedure and takes into account that an equivalent to the LISTEN channel list message was already received.

**NOTE:** The "old" transmitting side of a double simplex bearer stops transmissions after sending the RELEASE message. If the RELEASE message is not received correctly a timeout should cause a release on the "old" receiving side (see clause 11.5).

#### 10.7.2.4 REP relayed bearer release

In case of unacknowledged release procedure (see clause 10.7.2.1) of a bearer which has been mapped with another bearer (see clause 10.5.1.6):

- at the FT as transmitting side:
  - the radio channel and the associated TBC shall not be released after sending the RELEASE messages, IF it is an MBC decision to release the bearer and IF the channel is also interlaced with another channel (see clause 10.5.1.6 for definitions);
- at the FT as receiving side:
  - the radio channel and the associated TBC shall not be released after successful receiving of a RELEASE message IF the channel is also interlaced with another channel.

### 10.7.3 Expedited bearer release procedures

The expedited release procedures are used to effectively release a bearer in expedited connections. These messages only cause the release of the TBC. The connection is preserved at MBC level, therefore moving it to 'suspend' state.

#### 10.7.3.2 General Expedited Release procedure

The general expedited release procedure is used after a multi-burst bearer setup (see clause 10.5.1.8.3) or after a single-burst bearer setup which has been modified to be a multi-burst (see clause 10.5.1.8.3.2).

##### 10.7.3.2.1 Procedure description

###### **Predicates:**

- a) There is an existing MAC connection in active state (with an active bearer and TBC) between the PT-FT pair. The connection has an ECN number compatible with expedited procedure;
- b) One of the peers has sent the message "Ready for Release" (with or without B-field content) and this message has been successfully received by the other peer;
- c) The peer which has received the "Ready for Release" has no more data (U-plane or C-plane) for transmission (including retransmissions when allowed);
- d) In normal cases, previously to predicate b), there should have been a transmission of either, a "Ready for Release" or an "Expedited Access Request Ready for Release" message in the opposite direction.

**Procedure description:**

The peer which has received the "Ready for Release" shall be the initiating side of the release procedure.

The procedure is based on the exchange of two "Expedited Release" messages

Frame 1, transmitted by the initiating side (either PT to FT) with the following content:

- A-field header
  - TA =  $M_T$
  - BA = no-B-field
- $M_T$ : message "Expedited Release"
  - Reason code and info: any valid value
  - $G_{FA}$ : last valid ACK RN
- B-field: no B field

Frame 1 or 2 (next half-frame) transmitted in opposite direction with the following content:

- A-field header
  - TA =  $M_T$
  - BA = no-B-field
- $M_T$ : message "Expedited Release"
  - Reason code and info: any valid value
  - $G_{FA}$ : last valid ACK RN
- B-field: no B field

### 10.7.3.2.2 Exceptional cases and error handling

The following response shall be used in case of errors in the procedure:

**By the initiating side:**

Error case: no reception of the second "Expedited release" message.

- The action shall be repetition and restart of the procedure at the next half frame (transmission of a new Expedited Release and waiting for reply)

**By the other side:**

Error case: no reception of the first "Expedited release" message.

- The other side cannot be aware of the initiation or the procedure, however:
  - If the error happened in the next frame following the transmission of the "Ready for Release", the other side shall retransmit the "Ready for Release" as result of the rule given in clause 10.5.1.8.4.1.
  - In any other case, the other side shall do nothing.

### 10.7.3.3 Special cases of expedited release procedures

#### 10.7.3.3.1 Single-message expedited release procedure

As part of the Single-burst setup procedure (see clause 10.5.1.8.2), and assuming that the procedure is not modified to multi-burst (see clause 10.5.1.8.2.3), there is a release procedure (see description of the procedure in clause 10.5.1.8.2). In this case, the embedded release procedure uses a single "Expedited release" message. This is an exception to the general procedure that uses two messages.

#### 10.7.3.3.2 Abnormal expedited release procedure

In the following error cases:

- For the FT, in case of:
  - 1) correct reception of a PT first setup message (that may be either "expedited access request" or "Expedited Access Request Ready for Release");
  - 2) transmission of a response message different from "Expedited Release"; and
  - 3) not reception of the second PT > FT message in the second frame.
- For the initiating side, in case of:
  - 1) correct reception of the response to the first setup message, being either (the response) "Bearer Confirm" or "Ready for Release";
  - 2) transmission of any other message in frame 2; and
  - 3) lack of reception of a correct response to this "other" message.

THEN:

- The response shall be sending a single "Expedited Release" the next half-frame and dropping the TBC. The release reason "timeout, loss of signal" may be used.

## 10.8 C/O data transfer

### 10.8.1 Higher layer associated signalling (C)

All higher layer control ( $C_S$  and  $C_F$  channel data) is protected by a MAC layer ARQ procedure. This procedure is based on the principle that a data transmitter shall retransmit  $C_S$  and  $C_F$  segments when no acknowledgements for these segments have been received.

For the transmission of C channel data time windows called ARQ windows are defined. These ARQ windows start with the normal TDMA half frame for transmissions. Therefore, the windows are different for FT and PT:

- ARQ windows for FT start with slot 0;
- ARQ windows for PT start with slot 12.

#### 10.8.1.1 $C_S$ channel data

The  $C_S$  data service is a low rate service with a variable throughput of maximum 2 kbit/s. Independent of the number of bearers controlled by an MBC a maximum of one  $C_S$  segment may be transmitted in a given direction in an ARQ window of 10 ms. The same segment may, however, be duplicated over several bearers.

### 10.8.1.1.1 Transmission principle

- a) Those TDMA frames where the T-MUX algorithm does not allow  $C_T$  messages (see clause 6.2.2.1) shall not be used for transmissions of  $C_S$  segments.
- b)  $C_S$  data shall be sent only on duplex bearers. The same  $C_S$  segment may be sent on several duplex bearers during one frame. Only one  $C_S$  segment shall be transmitted within one ARQ window.
- c) If a  $C_S$  segment is sent in one particular ARQ window the successful transmission of this segment is confirmed when an acknowledgement is received in the second half of the same ARQ window on any of those duplex bearers which carried the  $C_S$  segment. Successful acknowledgement is achieved when the A-field of at least one of these bearers was received by the sending side of the  $C_S$  segment without CRC failure and with the Q2 bit in the header set to "1".
  - c1) for MAC service  $I_N$ , in the direction FT to PT an acknowledgement is also given when Q2 equals "0" and Q1 is set to "1" (Q1 and Q2 bit setting, see clause 10.8.1.3.1);
  - c2) for MAC service  $I_{P\_error\_detect}$ , in both directions, an acknowledgement is also given when Q2 equals "0" and Q1 is set to 1 (Q1 and Q2 bit setting, see clause 10.8.1.3.2);
  - c3) for MAC service  $I_{P\_error\_correct}$ , in both directions, an acknowledgement is only given when Q2 equals "1" (since the bit  $a_3$  is used to code the BCK bit);
  - c4) when the B-field mux is in any E-mux or E+U-mux mode, an acknowledgement is also given when Q2 equals "0" and Q1 is set to "1" in both directions (Q1 and Q2 bit setting, see clause 10.8.1.3.4), except if E+U mode is used in combination with  $I_{P\_error\_correct}$  (in such a case rule c3 applies).
- d) A  $C_S$  segment shall be retransmitted until the successful transmission of this segment is confirmed. Retransmission shall be done before another  $C_S$  segment is transmitted in the same data direction.

NOTE: In the cases coded by the rules c3 and c4, there may be retransmission of the B-field and no retransmission of the A.-field. This may happen due to the Q2 / BCK settings in  $I_{P\_error\_correct}$  or due to  $C_F$  or  $I_{PF}$  retransmission schemas in E-mux. In such cases, the  $C_S$  segment should not be retransmitted and the A-field should advance to the next  $C_S$  segment or change to other T-mux channel depending on the case.

### 10.8.1.1.2 Numbering principle

- a) A one bit packet number is assigned to each  $C_S$  segment. The number shall alter for successive  $C_S$  segments. In databursts containing  $C_S$  segments this packet number is transmitted in the tail identification field of the A-field header (see clause 7.1.2).
- b) Packet number "1" shall be assigned to the first  $C_S$  segment transmitted by an MBC.

### 10.8.1.2 $C_F$ channel data

A  $MAC\_CO\_DATA$ -req primitive carrying  $C_F$  channel data delivers a set of  $C_F$  segments to the MBC. The number of  $C_F$  segments building this set may be equal to or less than the maximum number of acceptable segments indicated by the MBC with the  $MAC\_CO\_DTR$ -ind primitive (see clause 8.4). The maximum number shall always be chosen such that all  $C_F$  segments can be transmitted in the B-field of one databurst.

$C_F$  channel data is transmitted as sets of  $C_F$  segments, a set of 1 segment for half slot, up to 4 segments for full slot, up to 8 segments for long slot ( $j=640/672$ ), and up to 10 segments for double slot. Thus either all the  $C_F$  segments of one single MAC\_CO\_DATA-req primitive are contained in the B-field of an E-type databurst or no  $C_F$  data at all is in the B-field. The mapping of the  $C_F$  segments onto the B-field is described in clause 6.2.2.3.

#### 10.8.1.2.1 Transmission principle

- a)  $C_F$  data shall be sent only on duplex bearers. The same set of  $C_F$  segments may be sent on several duplex bearers during one ARQ window. Only one set of  $C_F$  segments shall be transmitted within one ARQ window.
- b) If a set of  $C_F$  segments is sent in one particular ARQ window the successful transmission of this set is confirmed when an acknowledgement is received in the second half of the same ARQ window on any of those bearers which carried the  $C_F$  data. Successful acknowledgement is achieved when the A-field of at least one of these bearers was received without CRC failure and with the Q2 bit in the header set to 1. (Q2 bit setting, see clause 10.8.1.3).
- c) A set of  $C_F$  segments shall be retransmitted until the successful transmission of this set is confirmed. Retransmission shall be done before another set of  $C_F$  segments is transmitted in the same data direction.

NOTE 1: Retransmissions of an already acknowledged set of  $C_F$  segments is allowed as long as no new set of  $C_F$  segments is transmitted.

NOTE 2: Step c) implies that retransmissions may occur on another bearer and/or with interruptions. As a consequence the receiver should not accept any  $C_F$  data when the A-field CRC failed.

NOTE 3: E-type databursts containing MAC control only (e.g. release) may follow  $C_F$  transmissions on a bearer even when the  $C_F$  data are not yet acknowledged.

#### 10.8.1.2.2 Numbering principle

- a) A one bit packet number is assigned to each set of  $C_F$  segments. The number shall alter for successive sets. In databursts containing a set of  $C_F$  segments this packet number is transmitted in the BA identification of the A-field header (see clause 7.1.4).
- b) Packet number "1" shall be assigned to the first set of  $C_F$  segments transmitted by an MBC.

#### 10.8.1.3 Q1 and Q2 bit settings for all services except $I_P\_error\_correct$

For the coding of the bits for  $I_P\_error\_correct$ , see clause 10.8.2.4.1

##### 10.8.1.3.1 Q1 and Q2 bit settings for MAC service $I_N$

The Q1 and Q2 bits are used for C channel flow control and for quality control. The setting of the Q2 bit fulfils all necessary requirements to guarantee a reliable C channel data service.

The setting of the Q1 bits may report some further quality details which can improve the functionality. Nevertheless, the setting of Q1 is optional for service  $I_N$  and the meaning depends on the transmission direction.

Tables 10.2 and 10.3 give an overview of the Q1 and Q2 bit setting for both directions.

**Table 10.2: Q1 and Q2 sent from PT to FT for MAC service  $I_N$**

| Q1 bit setting                                                                                     |   | Q2 bit setting |                    |
|----------------------------------------------------------------------------------------------------|---|----------------|--------------------|
| antenna switch request                                                                             | 1 | 1              | A-field CRC passed |
| no special action from FT requested                                                                | 0 | 0              | A-field CRC failed |
| NOTE: When the B field multiplexer is in any E-mux mode (including $C_F$ ), see clause 10.8.1.3.5. |   |                |                    |

**Table 10.3: Q1 and Q2 sent from FT to PT for MAC service I<sub>N</sub>**

| Q1 setting for given Q2                                                                                                                                                   |   | Q2 bit setting |                                           |
|---------------------------------------------------------------------------------------------------------------------------------------------------------------------------|---|----------------|-------------------------------------------|
| sliding collision                                                                                                                                                         | 1 | 1              | A-field CRC passed AND                    |
| no sliding collision                                                                                                                                                      | 0 | 1              | X-field CRC passed (optional, see note 1) |
| A-field CRC passed                                                                                                                                                        | 1 | 0              | A-field CRC failed OR                     |
| A-field CRC failed                                                                                                                                                        | 0 | 0              | X-field CRC failed (optional, see note 1) |
| NOTE 1: The use of X-CRC for B-field quality control is optional and the acceptance criteria is up the implementer. It is allowed to base Q2 setting on A-field CRC only. |   |                |                                           |
| NOTE 2: When the B field multiplexer is in any E-mux mode (including C <sub>F</sub> ), see clause 10.8.1.3.5.                                                             |   |                |                                           |

### 10.8.1.3.2 Q1 and Q2 bit settings for MAC service I<sub>p\_error\_detect</sub>

The Q1 and Q2 bits are used for C channel flow control and for quality control. The setting of the Q2 bit fulfils all necessary requirements to guarantee a reliable C channel data service and provides feedback on the correct reception of user data.

The setting of the Q1 bits may report some further quality details which can improve the functionality. The meaning of Q1 depends on the transmission direction.

The following two tables give an overview of the Q1 and Q2 bit setting for both directions.

**Table 10.4: Q1 and Q2 sent from PT to FT for MAC service I<sub>p\_error\_detect</sub>**

| Q1 bit setting                                                                                              |   | Q2 bit setting |                                                   |
|-------------------------------------------------------------------------------------------------------------|---|----------------|---------------------------------------------------|
| antenna switch request                                                                                      | 1 | 1              | (A-field CRC passed) AND (all B-field CRC passed) |
| no special action from FT requested                                                                         | 0 | 1              |                                                   |
| A-field CRC passed                                                                                          | 1 | 0              | (A-field CRC failed) OR (any B-field CRC failed)  |
| A-field CRC failed                                                                                          | 0 | 0              |                                                   |
| NOTE: When the B field multiplexer is in any E-mux mode (including C <sub>F</sub> ), see clause 10.8.1.3.5. |   |                |                                                   |

**Table 10.5: Q1 and Q2 sent from FT to PT for MAC service I<sub>p\_error\_detect</sub>**

| Q1 setting for given Q2                                                                                     |   | Q2 bit setting |                          |
|-------------------------------------------------------------------------------------------------------------|---|----------------|--------------------------|
| sliding collision                                                                                           | 1 | 1              | (A-field CRC passed) AND |
| no sliding collision                                                                                        | 0 | 1              | (all B-field CRC passed) |
| A-field CRC passed                                                                                          | 1 | 0              | (A-field CRC failed) OR  |
| A-field CRC failed                                                                                          | 0 | 0              | (any B-field CRC failed) |
| NOTE: When the B field multiplexer is in any E-mux mode (including C <sub>F</sub> ), see clause 10.8.1.3.5. |   |                |                          |

Clauses 10.8.1.3.3 and 10.8.1.3.4 describe the setting of Q1 and Q2 in more detail.

### 10.8.1.3.3 Q2 bit settings

For duplex bearers the Q2 bit is the bit a<sub>7</sub> of the A-field header. This bit is used to report bearer quality in I<sub>p</sub> service and it is also used for G<sub>F</sub>, C<sub>S</sub> and C<sub>F</sub> channel flow control. The Q2 bit shall be set in response to the last received databurst on this bearer.

The quality of double simplex bearer shall be reported with the bearer quality control message defined in clause 7.3.4.4. This message provides a Q2 bit for each simplex bearer. The location of the Q2 bits depends on the Logical Bearer Number (LBN). The Q2 bits reserved for established double simplex bearers shall be set according to the last known quality results. The Q2 bits reserved for non-existing double simplex bearers shall be set to "0".

NOTE 1: No C<sub>F</sub> and G<sub>F</sub> channel data is transmitted on double simplex bearers.

NOTE 2: For double simplex bearers the bit a<sub>7</sub> of the A-field header is always set to 0.

Rules for Q2 bit setting:

- a) the Q2 bit is set to "0" whenever the A-field CRC fails. If the A-field CRC passes the Q2 bit setting is determined by the rules b), c), d) or e);
- b) if the B-field contains  $C_F$ ,  $G_F$  or MAC control (E-type mux), the Q2 bit is set to "1" if all non-empty B-field segments are received correctly. Otherwise it is set to "0";

Notes to rule b):

NOTE 3: A segment is considered received correctly if B-CRC passes and, in the specific case of  $C_F$ , if data is accepted by higher layers.

- c) if the B-field contains an  $I_P$  segment the Q2 bit shall be set to "1" if all B-field CRC passes and to "0" if any B-field CRC fails;
- d) if the B-field contains an  $I_N$  segment the Q2 bit setting depends on the transmission direction:
  - d.1) **Data from FT to PT, Q2 from PT to FT:** The Q2 bit shall be set to "1";
  - d.2) **Data from PT to FT, Q2 from FT to PT:** The Q2 bit may either be set to "1" or report if the B-field data were accepted. In the latter case the Q2 bit shall be set to "1" for accepted B-field data and to "0" for rejected B-field data. It is the manufacturer's freedom to define the rules for accepting B-field data.

Notes to rule d.2):

NOTE 4: Manufacturers should set the Q2 bit according to B-field data acceptance. This option enables PTs to initiate a bearer handover whenever the bearer quality is bad. Tests may be based e.g. on the X-field CRC result or on  $R_B$  CRC results of B-subfields if MAC control was received.

NOTE 5: Q2 set to "1" is also an acknowledgement for received  $C_S$  data (duplex bearers only). If the setting of the Q2 bit depends on the acceptance of B-field data the Q1 bit setting option to report the A-field CRC result should also be applied. Otherwise the  $C_S$  data throughput may suffer.

The peer side can use the information transmitted in the Q2 bit for a quality control algorithm, initiating antenna diversity, bearer replacement and/or handover.

#### 10.8.1.3.4 Q1 bit settings

For duplex bearers the Q1 bit is the bit  $a_3$  of the A-field header.

The Q1 bit for double simplex bearers in reverse direction is located in the bearer quality control message defined in clause 7.3.4.4. This message provides a Q1 bit for each simplex bearer. The location of the Q1 bits depends on the Logical Bearer Number (LBN) of the related double simplex bearer. All Q1 bits reserved for non-existing double simplex bearers shall be set to "0".

NOTE 1: For double simplex bearers the bit  $a_3$  of the A-field header is always set to 0.

The setting of the Q1 bit has different rules for both directions, and depending on the setting of Q2. Q1 bit is used to refine the CRC feedback, to request an antenna switch, or to indicate a sliding collision.

Rules for Q1 bit setting:

- a) If Q2 bit is set to "0" then the Q1 bit shall be set to "1" if A-field was received correctly (A-field CRC passed) and to "0" otherwise.

Notes to rule a):

NOTE 2: For MAC service  $I_N$ , the setting of Q1 according to the A-field CRC is optional. It is allowed to set Q1 always to "0". However, if the setting of the Q2 bit depends on the acceptance of B-field, then the setting of Q1 becomes mandatory (see clause 10.8.1.3.3, note 5).

NOTE 3: For MAC service  $I_P$ , the setting of Q1 is mandatory.

- b) If Q2 bit is set to "1" then meaning of Q1 depends on transmission direction:
- b.1) **Q1 transmitted in direction PT to FT (data from FT to PT):** An RFP may be provided with antenna diversity. The PT may request the FT to switch the antenna by setting the Q1 bit to "1". Otherwise the Q1 bit is set to "0".

Notes to rule b.1):

NOTE 4: For both,  $I_N$  and  $I_P$ , requesting to switch the antenna is optional. It is allowed to set Q1 always to "0".

NOTE 5: The PT can request the antenna switch due to different reasons, for instance changes in the signal level.

NOTE 6: The PT cannot use this bit to request antenna switch in case of bad A or  $I_P$  B field (Q2=0). However, in such a case, the PT could expect the other peer to perform some action -including antenna switch- as response to the Q2 reporting.

- b.2) **Q1 transmitted in direction FT to PT (data from PT to FT):** Q1 set to "1" indicates a detected sliding collision with another radio signal. Otherwise Q1 is set to "0"; If the option of reporting sliding collisions is applied the setting of the Q1 bit shall report a collision on one single received databurst on this bearer (i.e. no statistical averaging shall be applied).

Note to rule b.2):

NOTE 7: For both,  $I_N$  and  $I_P$ , the indication of sliding collision is optional. It is allowed to set Q1 always to "0".

The peer side can use the information transmitted in the Q1 bit for a quality control algorithm, initiating antenna diversity, bearer replacement and/or handover.

#### 10.8.1.3.5 Q1 and Q2 settings when B-field is in E-mux modes

This clause only applies to duplex bearers.

When the BA bits are switched to any mux mode different from U-plane transmission (BA bits "000"B and "001"B) or "no-B-field" the coding of Q1 and Q2 bits shall generally be done as indicated for MAC service  $I_{P\_error\_detect}$  (clause 10.8.1.3.2) with some differences. However in the following case the coding shall use the criteria used for  $I_{P\_error\_correct}$ :

When E+U type mux is supported (channel  $I_{PF}$ ), E/U-mux switches to E+U mode and the underlying MAC service was  $I_{P\_error\_correct}$ , then the  $I_{PF}$  channel operates also in Mod-2 protected operation. In such a case the bits are set as indicated for  $I_{P\_error\_correct}$  (clause 10.8.2.4.1), taking into account that the BCK refers to the Mod-2 sequence of the  $I_{PF}$  channel transmission (see clause 10.8.4.4).

For all other cases, the coding shall be as for  $I_{P\_error\_detect}$  with the differences described below.

NOTE 1: This includes MAC control, C-mux mode and mixed modes.

The following differences compared to  $I_{P\_error\_detect}$  behaviour are allowed:

- 1) When  $C_F$  segments are received, it is allowed to report  $Q2 = 0$ , what requests retransmission of the  $C_F$  segments, even if all B-field CRCs have been received correctly, but the  $C_F$  segments have not been accepted, by any reason (for example, by flow control reasons).
- 2) It is allowed not to consider the CRC of not used B-fields in the calculation of "B-field CRC passed". "Not used B-fields" are understood as those B-fields which are known not to be used due to the previous reception of a "NULL or  $I_{PF}$  segmentation info" message with the proper content.

The following B-field segments may be identified as "not-used":

- With BA codes 100 and 101 (mixed  $C_F$  / MAC control modes), all MAC control fields after a "NULL message" and before the starting of  $C_F$  and also the last unused  $C_F$  fields if the " NULL" indicates in the NCF the number of used  $C_F$  segments.



- With BA code 110 and  $I_{PF}$  channel not used (all MAC control mode), all MAC control fields after a "NULL message" that should not contain any of the E+U mode segmentation codes (see clause 7.3.3, table 7.50).

NOTE 2: In general, the same subfield carrying the first "NULL" message cannot be identified as "not-used" since its content cannot be known.

Tables 10.6 and 10.7 give an overview of the Q1 and Q2 bit setting for both directions.

**Table 10.6: Q1 and Q2 sent from PT to FT when the B-field is in E-mux modes**

| Q1 bit setting                                                                                                                                                                                                            |   | Q2 bit setting |                                                                                                                              |
|---------------------------------------------------------------------------------------------------------------------------------------------------------------------------------------------------------------------------|---|----------------|------------------------------------------------------------------------------------------------------------------------------|
| antenna switch request                                                                                                                                                                                                    | 1 | 1              | (A-field CRC passed) AND (all used B-field CRC passed (see note)) AND (all $C_F$ accepted when $C_F$ segments were received) |
| no special action from FT requested                                                                                                                                                                                       | 0 | 1              |                                                                                                                              |
| A-field CRC passed                                                                                                                                                                                                        | 1 | 0              | (A-field CRC failed) OR (any used B-field CRC failed (see note)) OR (one or more $C_F$ segments not accepted)                |
| A-field CRC failed                                                                                                                                                                                                        | 0 | 0              |                                                                                                                              |
| NOTE: It is allowed not to consider the CRC B-fields that are known not to be used in the calculation of "B-field CRC passed/failed". See text in this clause and clause 10.8.1.3.3 for detailed Q2 bit setting criteria. |   |                |                                                                                                                              |

**Table 10.7: Q1 and Q2 sent from FT to PT when the B-field is in E-mux modes**

| Q1 setting for given Q2                                                                                                                                                                                                   |   | Q2 bit setting |                                                                                                                                         |
|---------------------------------------------------------------------------------------------------------------------------------------------------------------------------------------------------------------------------|---|----------------|-----------------------------------------------------------------------------------------------------------------------------------------|
| sliding collision                                                                                                                                                                                                         | 1 | 1              | (A-field CRC passed) AND (all used B-field CRC passed (see note)) AND (all $C_F$ accepted when $C_F$ segments were received (see note)) |
| no sliding collision                                                                                                                                                                                                      | 0 | 1              |                                                                                                                                         |
| A-field CRC passed                                                                                                                                                                                                        | 1 | 0              | (A-field CRC failed) OR (any used B-field CRC failed (see note)) OR (one or more $C_F$ segments not accepted (see note))                |
| A-field CRC failed                                                                                                                                                                                                        | 0 | 0              |                                                                                                                                         |
| NOTE: It is allowed not to consider the CRC B-fields that are known not to be used in the calculation of "B-field CRC passed/failed". See text in this clause and clause 10.8.1.3.3 for detailed Q2 bit setting criteria. |   |                |                                                                                                                                         |

#### 10.8.1.3.6 Q1 and Q2 settings when B-field is in "no-B-field" mode

This clause only applies to duplex bearers.

When the BA bits are switched to "no-B-field" ("111"B), the coding of Q1 and Q2 bits shall be done as follows.

**Table 10.8: Q1 and Q2 sent from PT to FT for "no-B-field"**

| Q1 bit setting                                                                         |   | Q2 bit setting |                    |
|----------------------------------------------------------------------------------------|---|----------------|--------------------|
| antenna switch request                                                                 | 1 | 1              | A-field CRC passed |
| no special action from FT requested                                                    | 0 | 0              | A-field CRC failed |
| NOTE: The setting of Q1 bit is optional. It is allowed to set the bit Q1 always to "0" |   |                |                    |

**Table 10.9: Q1 and Q2 sent from FT to PT for "no-B-field"**

| Q1 setting for given Q2                                                                |   | Q2 bit setting |                    |
|----------------------------------------------------------------------------------------|---|----------------|--------------------|
| sliding collision                                                                      | 1 | 1              | A-field CRC passed |
| no sliding collision                                                                   | 0 | 1              |                    |
| reserved                                                                               | 1 | 0              | A-field CRC failed |
| A-field CRC failed                                                                     | 0 | 0              |                    |
| NOTE: The setting of Q1 bit is optional. It is allowed to set the bit Q1 always to "0" |   |                |                    |

### 10.8.1.3.7 Q1, Q2 and BCK settings when there are transitions in the coding rules or when the rules applicable to both directions are not the same

This case happens when there is a change in the coding rules or when they are not the same in both directions. This change may be consequence of a transition in the B-field multiplexer mode, or may be due to a change in the MAC service type. In such cases the following rule shall apply.

#### Rule:

When there is any change in the Q1 / Q2 / BCK coding rules, or when the rules applicable to both directions are not the same, the bits  $a_3$  and  $a_7$  in duplex bearers shall be coded according to the criteria applicable to the previous half-frame (to the half frame they acknowledge), irrespective of the content of the half frame that carries the bits.

**EXAMPLE1:** One peer receives an  $I_{p\_error\_correct}$  segment, but needs to switch the B-mux to E-type to transmit control messages. The bits  $a_3$  and  $a_7$  in such half-frame should carry the BCK and Q2 bits set according to  $I_{p\_error\_correct}$  rules (providing feedback to the received half-frame), even if the BA bits of the same frame are coded indicating E-mux and the B-field transports control messages.

**EXAMPLE 2:** The other peer in Example 1 receives an E-mux frame but wishes to continue the transmission of an  $I_{p\_error\_correct}$  segment. In such a case the bits  $a_3$  and  $a_7$  shall be coded according to E-mux mode rules (clause 10.8.1.3.5), and BA bits shall be coded indicating  $I_{p\_error\_correct}$ .

**NOTE:** Note than in the case described in Example 2, a frame transporting an  $I_{p\_error\_correct}$  segment carries a Q1 bit in bit  $a_3$ .

### 10.8.1.3.8 Q1 and Q2 settings when B-field mode is unknown

This clause only applies to duplex bearers.

When the B-field mode is unknown, for instance due to bad A-field CRC decoding, the bits  $a_3$  and  $a_7$  shall always be coded as follows: bit  $a_3$  = Q1 = "0" and bit  $a_7$  Q2 = "0".

## 10.8.2 MOD-2 protected I channel operation ( $I_P$ )

**NOTE:** This service is also known as " $I_{p\_error\_correct}$ ".

### 10.8.2.1 General

The modulo-2 procedure uses a 2-state packet number in the A-field header. This packet number applies to the complete B-field of  $I_P$  data. The first  $I_P$  packet sent on a new logical bearer is labelled with packet number "1".

Successful reception of the data is acknowledged independently for each logical bearer. For duplex bearers the acknowledgement mechanism uses the Q2 and the BCK bits in the return A-field header. For double simplex bearers, these bits, the Q2 and BCK bits, for each logical simplex bearer are multiplexed into a "MAC-MOD2-ACK" message, and this message is sent in at least one B-subfield on at least one reverse bearer.

MOD-2 operation in the asymmetric case shall use the E32-mux or the E80-mux in the reverse direction.

**NOTE:** The MOD-2 receiver may use selective reception, or even majority voting to achieve CRC success.

The MOD-2 protected I channel operation ( $I_{p\_error\_correct}$ ) service can operate using either, the single-subfield protected format, as defined in clause 6.2.1.3.4, the constant-size-subfield protected format, as defined in clause 6.2.1.3.5, or the multi-subfield protected format as defined in clause 6.2.1.3.3. The variant of the service using the single-subfield protected format is called  $I_{PQ\_error\_correct}$  or  $I_{PQR}$ . The variant of the service using the constant-size-subfield protected format is called  $I_{PK\_error\_correct}$  or  $I_{PKR}$ . The variant of the service using the multi-subfield protected format is called  $I_{PM\_error\_correct}$  or  $I_{PMR}$ .

### 10.8.2.1.1 Use of selective reception

When using MAC service  $I_{PMR}$ , the receiver side may use (implementation option) selective reception, in the sense that subfields correctly received may be accepted, even if there are subfields with bad CRC.

The receiver implementing selective reception may also implement selective combination, in the sense that several receptions of the same retransmitted packet may be combined to create a completely correct packet.

NOTE 1: With current definition of DLC services LU2 and LU10 (see EN 300 175-4 [4]), selective retransmission without combination is, in general, only useful when the E/U multiplexer is in E or E+U mode. In such case the receiver may use the correctly received subfields carrying signalling or  $I_{PF}$  data. Useful decoding of the bearer in U-mode is only possible in special cases, such as when the payload of a DLC PDU is contained entirely in correctly received subfields, and only padding field is transmitted in badly received subfields.

NOTE 2: It may also be useful to decode possible FU10c frames transmitted by insertion in FU10a frames.

When using MAC service  $I_{PQR}$ , or MAC service  $I_{PKR}$  in 2-level modulation, the receiver side may use (implementation option) selective reception applied when the E/U multiplexer is in E or E+U mode, and may use selective reception and combination when the E/U mux is in U-mode.

NOTE 3: The use of selective reception without selective combination when MAC service is  $I_{PQR}$  and the E/U mux is in U-mode is meaningless.

When using MAC service  $I_{PKR}$  in HLM (4 or higher modulation levels), the receiver side SHALL support selective reception in all (U-mux, E-mux or E+U-mux) modes. Selective combination is not needed in this case.

NOTE 4: Selective reception alone is useful in this case, since each subfield carries a complete PDU (see EN 300 175-4 [4])

For all MAC services: regarding the operation of the MAC-mod2 retransmission mechanism, when selective reception is implemented, it is an implementation decision the criteria to consider the bearer correctly received, or to request a retransmission via Q2/BCK bits. The receiver may choose to use: unanimity, majority vote, or reinforced majority vote (good CRC > x, where x > 50 %). The receiver may also adjust the criteria depending on the previous retransmission history and the remaining lifetime of the packet.

### 10.8.2.2 Limiting the lifetime of packets

The originating entity (the sender of packets) is required to limit the lifetime of every data packet to an integral number of TDMA frames, according to the service demanded by the DLC layer in the MAC\_CON-req primitive.

This requirement shall be met by stopping the MOD-2 retransmission of any packet that exceeds this time limit, irrespective of whether an acknowledgement has been received from the peer TBC. This process will typically cause invocation of one of the "data jump" procedures described in clause 10.8.2.5.

#### 10.8.2.2.1 Lifetime setting and management

The DECT system may operate with two different options regarding use of lifetime parameters:

##### 10.8.2.2.1.1 Operation with ONE maximum MAC packet lifetime parameter.

This is the historic use of the parameter in DECT, and the only one until the revision v2.4.1 of the present document. A single maximum packet lifetime parameter is set by means of the Attributes\_T, Attributes\_B or Bearer\_Request (B-field) control messages with the values as defined by table 7.32a of clause 7.2.5.3.8. Such parameter shall be understood as Overall MAC maximum packet lifetime. The possible setting range of the parameter is from 1 to 7 frames plus infinite.

#### 10.8.2.2.1.2 Operation with TWO maximum MAC packet lifetime parameters.

From revision v2.5.1 of the present document, it is possible the operation with two parameters limiting separately the lifetime of a packet in a given TBC and in the overall MAC layer. If this option is used, the parameter defined by the MAC control messages (Attributes\_T, Attributes\_B or Bearer\_Request (B-field)) shall be understood as the maximum TBC packet lifetime, and a separate parameter shall be used to indicate the overall MAC maximum packet lifetime.

The new parameter indicating the overall MAC maximum packet lifetime may be set by any of the following options:

- It may be defined as a fixed configuration parameter in an Application Profile.
- It may be set using the Network Layer Information element <<Transit-Delay>> (as defined in EN 300 175-5 [5], clause 7.7.42).
- It may be integrated into the definition of a NWK layer Basic Service and set by the transmission of the IE <<Basic Service>> as defined in EN 300 175-5 [5], clause 7.6.4.

When the option of using the IE <<Transit-Delay>> for setting the overall MAC maximum packet lifetime parameter, the range of possible values are 1 to 63 plus infinite. The range for the TBC max packet lifetime set using the MAC control message, continues being 1 to 7 frames plus infinite.

#### 10.8.2.2.1.3 Lifetime management in the operation with TWO maximum MAC packet lifetimes

When the operation with TWO maximum MAC packet lifetimes is chosen, the following provisions apply.

A packet may be retransmitted in the same TBC until the expiration of the TBC max packet lifetime counter.

A packet may be rescheduled to other TBC (bearer) for retransmission, and this may be repeated as long as needed, until the expiration of the overall MAC maximum packet lifetime.

The overall MAC packet lifetime counter shall be started for the packet with the maximum value when it is delivered to the MAC layer for transmission and shall be decreased with absolute TDMA frames. The remaining value of this counter shall be used for controlling the lifetime when it is re-scheduled between TBCs.

In case of TBC re-scheduling, a new TBC lifetime counter shall be started for the TBC (in addition to the overall MAC lifetime counter).

The TBC re-scheduling may happen by any of the following mechanisms:

- By diverting a packet to an already established, but different, TBC in a multibearer connection;
- By setting up a new TBC, for instance (but not necessarily) by performing a bearer replacement;
- By performing a bearer handover;

For the purposes of this rule, bearer handovers are considered as if a new TBC is set (therefore a new TBC lifetime counter starts).

#### 10.8.2.2.1.4 Operation of the counters

The overall MAC packet lifetime counter shall be started for the packet with the defined maximum value when it is delivered to the MAC layer for transmission and shall be decreased with absolute TDMA frames (every 10 ms), irrespective of if there is an active TBC or not. In other words, it shall count during suspension times or during idle periods of time due to execution of channel selection or back off algorithms.

Nevertheless, in applications with ultra slow paging cycles, such as DECT ULE, it is allowed not to take in consideration the delay due the paging mechanism.

The TBC packet lifetime counter starts to count with the first transmission over the TBC.

#### 10.8.2.2.1.5 Primitives interpretation in the operation with TWO maximum MAC packet lifetimes

When the operation with TWO maximum MAC packet lifetimes is chosen, the parameter "max lifetime" of the different primitives towards the MAC layer described in clause 8 shall be understood as passing both parameters; the TBC lifetime and the overall MAC lifetime.

#### 10.8.2.2.1.6 Identification of when operation with ONE maximum MAC packet lifetime or with TWO maximum MAC packet lifetimes are used

As general rule, an application profile shall define if the lifetime operation mode with ONE maximum MAC packet lifetime or with TWO maximum MAC packet lifetimes shall be used.

In case of lack of definition or ambiguity the following back-compatibility rules shall be used:

- For any DECT specification published before 31 of December of 2012, it shall be understood that the mode with ONE maximum MAC packet lifetime is used.
- Application profiles (including revisions) published from January 2013 should indicate which mode is used.
- The use of the NWK layer IE <<Transit Delay>> for setting the overall MAC maximum packet lifetime indicates that the operation mode with TWO lifetimes is used.

#### 10.8.2.3 A-field shall always be correct

The receive procedure is required to always receive the A-field successfully before accepting any of the B-field during MOD-2 operation.

NOTE: This requirement means that E-mode interruptions are allowed at any time. For example a B-field MAC message ("bearer release") can be sent on the old bearer during bearer handover, without causing an exception condition and risking data errors.

#### 10.8.2.4 Use of the acknowledge bits

During MOD-2 operation two bits are used for  $I_P$  channel flow control. These bits are located in different positions for duplex and double simplex bearers. The two bits are:

- the Q2 bit and the BCK bit in the A-field header at positions  $a_3$  and  $a_7$  as described in clause 7.1 for a duplex bearer;
- two pairs of a Q2 and a BCK bit in the quality control message described in clause 7.3.4.4 for a double simplex bearer.

The settings of the Q2 bit are described in clause 10.8.2.4.1.

The setting of the BCK bit is described in clause 10.8.2.4.2.

The two control bits Q2 and BCK in the A-field shall be set individually for each duplex bearer of a symmetric or an asymmetric connection.

The two control bits Q2 and BCK in the quality control message shall be set individually for each logical half of a double simplex bearer in asymmetric connections. The Q2 bits for non-existing logical double simplex bearers shall be set to "0" and the BCK bits to "1".

##### 10.8.2.4.1 Q2 and BCK bit setting for $I_P$ \_error\_correction services

###### Q2 bit setting for duplex bearer

The Q2 bit setting influences the retransmission mechanism from  $C_S$ ,  $C_F$  and  $I_P$  data. The setting of the Q2 bit is exactly the same as in  $I_P$ \_error\_detection services (see clauses 10.8.1.3.2 and 10.8.1.3.3).

NOTE: When an  $I_P$ \_error\_correct segment is received the Q2 bit is set to "1" if the A field and all B field CRCs are correct.

###### Q2 bit setting for double simplex bearer

Data received on a double simplex bearer is acknowledged on another bearer in reverse direction. The reverse bearer provides a Q2 bit for each simplex bearer in forward direction.

The Q2 bit on the reverse bearer does not influence the  $C_S$  and the  $C_F$  retransmission scheme and is set as follows:

- When an  $I_P$  segment was received (A-field CRC correct and the BA bits set to  $I_P$  segment with number 0 or 1) the Q2 bit is set to "1", regardless of the results of the B-field CRCs.

Exception: When receiving a RESET message (during an  $I_P$  bearer reset procedure, see clause 10.8.2.5.3) the Q2 bit shall be reset to "0".

#### 10.8.2.4.2 BCK bit setting

In MOD-2 mode the second control bit, BCK, is used to report the  $I_P$  packet number of the next expected  $I_P$  segment.

NOTE: A unilateral jump procedure (see clause 10.8.2.5.2) may toggle the BCK bit.

#### 10.8.2.5 Data jump procedures

"Data jump" is defined as the name for any procedure that is used to unstick a bearer that is failing to transmit its  $I_P$  data successfully. This is required to stop a retransmission when the packet lifetime has expired, or to stop a transmission if the packet has been rescheduled (via another bearer). There are three data jump procedures:

- new numbering sequence in case of bearer replacement;
- unilateral (unacknowledged) jump;
- $I_P$  bearer reset.

NOTE 1: In the preferred implementation the MBC functional block contains the data jump control.

NOTE 2: Data jump procedures may cause a loss and/or a duplication of data.

NOTE 3: Rescheduling of data packets has to be taken into account by the transmitting side in respect to the agreed packet lifetime. The rescheduled packets may be sent on any bearer of the connection.

##### 10.8.2.5.1 New MOD-2 numbering in case of Bearer replacement

If the bearer replacement procedure is executed (see clause 10.8.2.6.3), a new independent MOD-2 numbering sequence is started for the new bearer. The "old" bearer will continue its sequence, either advancing it, or performing retransmissions, until the bearer release.

##### 10.8.2.5.2 Unilateral jump

The unilateral jump process is described with two state tables, one for the transmitter, and one for the receiver.

#### Receiver:

The three state variables at the receiver are:

- LAST-BCK meaning "what packet number was transmitted in the last BCK bit to indicate the number of the next expected  $I_P$  segment".
- LAST-PKT meaning "what  $I_P$  packet number appeared in the last databurst containing  $I_P$  data".
- THIS-PKT-NO meaning "what  $I_P$  packet number appears in the databurst just received containing  $I_P$  data".
- NEXT-PK-NO meaning "what  $I_P$  packet number the Receiver shall ask for in the next burst".
- The variables LAST-PKT and THIS-PKT-NO can take three values: "0", "1" and "unknown". The value "unknown" is produced if it not possible to determine the  $I_P$  packet number appeared in the databurst. This situation is produced, for instance, when the CRC of A-field is incorrect.

The Receiver, after evaluating the received  $I_p$  packet (see clause 10.8.2.3) evaluates the state variables following table 10.10 to know how the Transmitter acted; after that, it evaluates the Rb-CRCs of all the B subfields and shall act as indicated in table 10.11.

**Table 10.10: Unilateral Jump TX action**

|                                                                                                        | THIS-PKT=LAST-PKT | THIS-PKT=LAST-BCK | How transmitter acted        |
|--------------------------------------------------------------------------------------------------------|-------------------|-------------------|------------------------------|
| (a)                                                                                                    | Yes               | Yes               | Retransmit                   |
| (b)                                                                                                    | No                | Yes               | normal advance               |
| (c)                                                                                                    | Yes               | No                | unnecessary retransmit       |
| (d)                                                                                                    | No                | No                | Jump                         |
| (e)                                                                                                    | Unknown           | Yes               | Either retransmit or advance |
| (f)                                                                                                    | Unknown           | No                | Either retransmit or jump    |
| (g)                                                                                                    | Unknown           | Unknown           | Unknown                      |
| NOTE: The states (e), (f) happens when LAST-PKT is unknown and the state (g) when THIS-PKT is unknown. |                   |                   |                              |

**Table 10.11: Unilateral Jump RX action**

| State (table 10.10)                                                                                                                                         | Rb-CRC result  | how Receiver shall act                                       |
|-------------------------------------------------------------------------------------------------------------------------------------------------------------|----------------|--------------------------------------------------------------|
| (g)                                                                                                                                                         | Not considered | NEXT-BCK = LAST-BCK                                          |
| (a), (b), (e)                                                                                                                                               | Rb-CRCs passed | NEXT-BCK = LAST-BCK + 1 (MOD 2)                              |
| (a), (b), (e)                                                                                                                                               | Rb-CRCs failed | NEXT-BCK = LAST-BCK                                          |
| (c)                                                                                                                                                         | Rb-CRCs passed | NEXT-BCK = LAST-BCK; RX still requires the same $I_p$ packet |
| (c)                                                                                                                                                         | Rb-CRCs failed | NEXT-BCK = LAST-BCK; RX still requires the same $I_p$ packet |
| (d), (f)                                                                                                                                                    | Rb-CRCs passed | NEXT-BCK = LAST-BCK                                          |
| (d), (f)                                                                                                                                                    | Rb-CRCs failed | NEXT-BCK = LAST-BCK + 1 (MOD 2)                              |
| NOTE: In cases (e) and (f), the receiver cannot be sure what was the action in the TX side. In these cases the packet should be delivered to the DLC layer. |                |                                                              |

#### Transmitter:

Define:  $LTIP$  = packet number of the last transmitted  $I_p$  segment.

The two state variables at the transmitter are:

- **ACKN** meaning "an  $I_p$  packet has been received in the receiver last databurst":
  - for duplex bearer the reception of the  $I_p$  packet is acknowledged by receiving an A-field correct and with the Q2 bit set to 1 (see clause 10.8.2.4.1);
  - for double simplex bearer the reception of the  $I_p$  packet is acknowledged by receiving an A-field correct and with Q1 bit set to 1 (see clause 10.8.2.4.1).

NOTE 1: For double simplex bearer this process is independent for both simplex bearers.

- **LAST-BCK** meaning "what was the setting of the last correct received BCK bit (with the BCK bit the receiver reports the next expected  $I_p$  packet)?".

NOTE 2: If ACKN switches to "yes" also a new BCK is received.

**Table 10.12**

|     | ACKN | $LTIP = LAST-BCK$ | How transmitter shall act      |
|-----|------|-------------------|--------------------------------|
| (a) | Yes  | No                | normal advance (or retransmit) |
| (b) | Yes  | Yes               | retransmit or jump             |
| (c) | No   | No                | retransmit or jump             |
| (d) | No   | Yes               | retransmit or jump             |

The transmitter shall use the jump procedure when the packet limit lifetime expires.

In state (b) the transmitter can choose between retransmission and jump. Its choice is reflected in the pkt number chosen. If jump the pkt number toggles if retransmit the pkt number is unchanged.

### 10.8.2.5.3 MAC I<sub>P</sub> bearer reset

Any databurst using E-Type or E+U type multiplexer interrupts the I<sub>P</sub> data flow on the physical channel of the logical bearer without warning. A MAC I<sub>P</sub> bearer reset on that half of the logical bearer which uses a particular physical channel is accomplished by the transmission of a RESET\_REQUEST message on that physical channel.

**NOTE:** During bearer handover one half of a logical bearer may consist of two physical channels, one physical channel belonging to the "old" bearer and one belonging to the "new" bearer. The reception of a RESET\_REQUEST message on either of these physical channels indicates an I<sub>P</sub> bearer reset. No U-type multiplex, i.e. I<sub>P</sub> channel data, would be sent on either of these physical channels until the MAC I<sub>P</sub> bearer reset is completed.

The transmitter (T-side) repeats the RESET\_REQUEST message on the same logical half bearer until a RESET\_CONFIRM message is received in reply or the bearer is released. No further I<sub>P</sub> data shall be sent on this bearer, until the reply is received.

The receiving end (R-side) of a RESET\_REQUEST message shall reset the packet number sequence variable and the receive buffers of that logical half bearer on which the message was received. The R-side shall reply with a RESET\_CONFIRM message. The RESET\_CONFIRM message may be transmitted on any bearer with capacity in direction to the T-side, and may be duplicated onto more than one bearer.

If possible the RESET\_REQUEST and RESET\_CONFIRM messages should be duplicated onto more than one B-subfield of a bearer. The RESET messages are defined in clause 7.3.4.3.

Upon receipt of RESET\_CONFIRM the T-side may resume transmission of I<sub>P</sub> data on the logical half bearer, starting with packet 1.

## 10.8.2.6 Bearer handover and bearer replacement procedures

### 10.8.2.6.1 General

In the event of repeated data errors, the bearer handover (see clause 10.6) or bearer replacement (see clause 10.6.4) procedures are the expected MAC responses.

### 10.8.2.6.2 Bearer handover in a MOD-2 protected I channel

In the bearer handover procedure, a new bearer with the same LBN is created. The same I<sub>P</sub> data segment shall be transmitted and the same MOD-2 numbering shall be used on both bearers. However, depending on the relative position of the "old" and "new" bearers, there can be a frame boundary between the two identical bearers.

- If the handover is executed to a bearer with a higher slot number, then, "old" and "new" bearers in the same frame shall carry identical I<sub>P</sub> data segment and shall have identical MOD-2 number.
- If the handover is executed to a bearer with a lower slot number, then, "old" bearer in frame n and "new" bearer in frame n+1 shall carry identical I<sub>P</sub> data segment and shall have identical MOD-2 numbering.

### Duplex bearers

During a duplex bearer handover, the receiver side shall set the Q2/BCK bits independently for each identical bearer in the handover. The transmitter side shall evaluate the Q2/BCK bits of both identical bearers taking into account the possible frame boundary between them (as described in this clause). The recommended response for the transmitter side is as follows:

- If both bearers have been received successfully (Q2=OK and BCK requesting "advance") THEN: perform "normal advance" (on both, "old" and "new" bearers).



- If one of the bearers has been received successfully (Q2=OK and BCK requesting "advance") and not the other, THEN: perform advance on both bearers (that will be equivalent to a "jump" in the erroneous bearer), AND take into account the result for the handover algorithm.
- If both bearers have been received with error (Q2=fail OR BCK requesting not to advance) THEN: perform "retransmission" on both bearers.

However, due to the inherent complexity of bearer handover implementation on MOD-2 protected channels, the real response is left to the Tx implementation (always within the possibilities described in this clause).

### Double simplex bearer

During bearer handover of a double simplex bearer, the acknowledge results for the old and the new bearer (bearers with the same LBN) should be combined to produce a single set of results. The relative position of the "old" and "new" bearers shall be taken into account for the calculation (as described in this clause), as well as the relative position of the bearer quality feedback message (see clause 7.3.4.4).

The recommended implementation for the receiver side is setting the Q2/BCK bits as the quality evaluation of the "new" bearer as soon it is received. In case of handover roll back (release of the new bearer), the setting will return to the "old" bearer.

NOTE: Due to the fact that currently it is not possible to send separate quality feedback (in the "bearer quality in asymmetric connection" message, see clause 7.3.4.4) for both bearers involved in the handover, and that this information is fundamental for the handover completion decision, the bearer handover procedure is not recommended for double simplex bearers. Instead of it, the bearer replacement procedure may be used.

#### 10.8.2.6.3 Bearer replacement in a MOD-2 protected I channel

"Bearer replacement" is defined to be the case where an old bearer is replaced with a new bearer that has a different LBN. For bearer replacement the new bearer contains independent packet numbering for I<sub>P</sub> MOD-2 protected data. In multibearer connections the replacement may be performed, either setting first the new bearer and then dropping the original one, or dropping first the old bearer and setting then the new one.

NOTE 1: For protected data connections the preferred procedure to delete an old bearer and setup a new one is the Bearer Replacement procedure (see clause 10.6.4).

NOTE 2: For multibearer packet mode data connections, and for all bearers except the last duplex bearer, it is recommended to execute the bearer replacement procedure dropping first the old bearer and then setting-up the new one.

NOTE 3: In case the bearer replacement procedure is used for connections where the agreed target value equals the minimum, timer T201 allows the amount of bearers to be less than the minimum during 5 s.

In replacement procedures setting first the new bearer (two active bearers on the air), the data on the new bearer may be different data or may (still) be a duplicate of the data on the old bearer.

NOTE 4: The behaviour in this case is a Tx implementation decision that should take into account the relative importance of error correction capability versus throughput and the possible error correction mechanisms at higher layers.

#### 10.8.2.7 Exchange of data from/to higher layers

The I<sub>P</sub>\_error\_correct service operates as the I<sub>P</sub>\_error\_detect service, but taking into account that data is requested from the DLC, only at the beginning of bearers able to carry fresh (new) I<sub>P</sub> data segments.

At the beginning of each U-mux type bearer able to carry new I<sub>P</sub> data segments, the MBC shall ask DLC for an I<sub>P</sub> data segment with a MAC\_CO\_DTR-ind primitive. The DLC shall return a DLC PDU in a MAC\_CO\_DATA-req primitive (see clause 8.4). The MAC shall transmit the received packet as a new MOD-2 segment on the bearer.

No data is requested from the DLC if the bearer is performing a retransmission according to the MOD-2 protection mechanism described in this clause.

NOTE 1: The new packet will usually be numbered (MOD-2) sequentially after previous segment in the bearer. However, not in all cases, since the bearer may be performing an unilateral jump (see clause 10.8.2.5.2) or an  $I_P$  bearer reset (see clause 10.8.2.5.3). This may happen for instance, if the previous transmission on the bearer failed, and either, the lifetime of the packet has expired, or the MBC implementation decides to retransmit the packet on a different bearer.

NOTE 2: The two segments of data transmitted in two bearers with the same LBN during a bearer handover operation are duplicated. See clause 10.8.2.6.2.

At the receiving side, correctly received  $I_P$  channel packets shall be delivered to the DLC immediately.

If the  $I_P$  service is using the multi-subfield protected format (see clause 6.2.1.3.4), then the receiving side MAY combine the correctly received subfields over successive retransmissions in order to get a correctly received  $I_P$  segment.

#### 10.8.2.7.1 Operation if $I_{PF}$ channel is supported

if  $I_{PF\_channel}$  is supported (see clauses 5.3.1.4 and 10.8.4), just before the transmission of a bearer in E+U multiplexer mode and with capacity to carry  $I_{PF}$  segments belonging to a new  $I_P$  packet, the MBC shall request an  $I_P$  packet from the DLC with a `MAC_CO_DTR-ind` primitive. The DLC shall deliver a DLC PDU. The MBC shall segment the received packet into  $I_{PF}$  segments, shall add control information, and shall transmit a number of  $I_{PF}$  segments in the bearer. The MBC shall be in charge of transmitting the rest of  $I_{PF}$  segments of the  $I_P$  packet in next E+U mode bearers without any further request to the DLC.

The DLC sees no difference (other than the different delay) if a  $I_P$  packet is transmitted over a U-mode bearer or over channel  $I_{PF}$ .

At the receiving side, when all the  $I_{PF}$  segments of an  $I_P$  packet have been correctly received, the complete  $I_P$  packet is immediately delivered to the DLC.

If the U-plane mode is  `$I_P\_error\_correct$` , then the bearers in E+U type multiplexer are also protected using a MOD-2 mechanism as described in clause 10.8.2. In this case, the MOD-2 sequence numbering for E+U slots is independent of the MOD-2 sequence when the bearer is in U mode. If there would have slots carrying only plain E-type data (MAC signalling plus  $G_F$ ), they will be considered as E+U type for the purpose of the sequence numbering and BA header code.

### 10.8.3 Higher layer unprotected information ( $I_N$ ) and `MAC_error_detection` services ( $I_P$ )

#### 10.8.3.1 `$I_N\_minimum\_delay$` service ( $I_{NA}$ )

Each U-type databurst carries one  $I_N$  data segment. The MBC asks for each  $I_N$  data segment with a `MAC_CO_DTR-ind` primitive and receives one  $I_N$  segment from the DLC in a `MAC_CO_DATA-req` primitive (see clause 8.4).

NOTE: During bearer handover two established bearers may be assigned to one logical bearer. The  $I_N$  data segments transmitted in one TDMA frame on these two bearers need not be the same.

#### 10.8.3.2 `$I_N\_normal\_delay$` service ( $I_{NB}$ )

At the beginning of each TDMA half frame the MBC shall dispose of all I channel ( $I_N$  channel) segments which are transmitted in this TDMA half frame (see clause 8.4). The number of segments equals the number of logical simplex bearers which are allocated for I channel data transmissions in this TDMA half frame. The segments shall be assigned to the allocated logical simplex bearers in ascending order: the first segment to the logical simplex bearer with the smallest LBN number, the last segment to that bearer with the highest LBN number.

NOTE 1: There might exist additional logical simplex bearers which are reserved for transmissions of extended control.

NOTE 2: The list of available LBN numbers may be not continuous: In one TDMA half frame there might be 4 logical simplex bearers with e.g. LBNs 1, 2, 4 and 7 to transmit I channel data, one simplex bearer with LBN 6 which is used to transmit extended control and two logical simplex bearers with the LBN numbers 3 and 5 for receiving data. Bearers with successive LBNs might not be in consecutive slot order.

### 10.8.3.3 $I_{P\_error\_detection}$ service

The  $I_{P\_error\_detection}$  service operates as  $I_{N\_minimum}$  delay service, but using a B-field protected format. The service can operate using either, the single-subfield protected format, as defined in clause 6.2.1.3.3, the multi-subfield protected format as defined in clause 6.2.1.3.4, or the constant-size subfield protected format as defined in clause 6.2.1.3.5. The variant of the service using the multi-subfield protected format is called  $I_{PM}$ , the variant of the service using the single-subfield protected format is called  $I_{PQ}$  and the variant of the service using the constant-size subfield protected format is called  $I_{PK}$ .

At the beginning of each U type slot able to carry  $I_P$ -type data, the MBC shall ask for an  $I_P$  data segment with a  $MAC\_CO\_DTR$ -ind primitive. The DLC shall return an  $I_P$  data segment in a  $MAC\_CO\_DATA$ -req primitive (see clause 8.4). The MBC shall place the segment in the bearer. There is no delay at the MAC layer.

NOTE 1: When operating in  $I_{P\_error\_detect}$ , the two segments of data transmitted in two bearers with the same LBN during a bearer handover operation may be the same or different (implementation decision).

At the receiving side, correctly received  $I_P$  channel packets shall be delivered to the DLC immediately.

NOTE 2: Due to the fact that currently it is not possible to send separate quality feedback (in the "bearer quality in asymmetric connection" message, see clause 7.3.4.4) for both bearers involved in a bearer handover, and that this information is fundamental for the handover completion decision, the bearer handover procedure is not recommended for double simplex bearers. Instead of it, the bearer replacement procedure may be used.

NOTE 3: During a bearer replacement procedure (see clause 10.6.4) the two segments of data transmitted over "old" and "new" bearers may be the same (duplication) or different.

#### 10.8.3.3.1 Operation if $I_{PF}$ channel is supported

if  $I_{PF\_channel}$  is supported (see clauses 5.3.1.4 and 10.8.4), just before the transmission of a bearer in E+U multiplexer mode and with capacity to carry  $I_{PF}$  segments belonging to a new  $I_P$  packet, the MBC shall request an  $I_P$  packet from the DLC with a  $MAC\_CO\_DTR$ -ind primitive. The DLC shall deliver a DLC PDU. The MBC shall segment the received packet into  $I_{PF}$  segments, shall add control information, and shall transmit a number of  $I_{PF}$  segments in the bearer. The MBC shall be in charge of transmitting the rest of  $I_{PF}$  segments of the  $I_P$  packet in next E+U mode bearers without any further request to the DLC.

At the receiving side, when all the  $I_{PF}$  segments of an  $I_P$  packet have been correctly received, the complete  $I_P$  packet is immediately delivered to the DLC.

### 10.8.3.4 $I_{P\_encoded\_protected}$ service ( $I_{PX}$ )

The operation of the  $I_{P\_encoded\_protected}$  ( $I_{PX}$ ) operates as the  $I_{P\_error\_detect}$  service, but using the coding protection as described in annex I instead of CRCs (according to the r rate previously negotiated using MAC signalling).

NOTE: The  $I_{P\_encoded\_protected}$  ( $I_{PX}$ ) is a minimum delay service.

## 10.8.4 Higher layer U-plane channel ( $I_{PF}$ ) in E+U type mux

### 10.8.4.1 Purpose of the $I_{PF}$ channel

The  $I_{PF}$  channel is used to transport U-plane data over slots with B-field multiplexer type E+U (see clause 6.2.2) and not all subfields used by signalling channels.  $I_{PF}$  allows to use the remaining subfields of the slot for transporting user data.

The  $I_{PF}$  channel transports data packets of the standard size (PDU) defined by the MAC plane service in use ( $I_P$ ,  $I_{PK}$  or  $I_{PQ}$ ) and slot type. In order to insert these packets over the reduced capacity E+U slot, the  $I_{PF}$  channel uses an adaptation procedure that transport information on the PDU boundaries by means of MAC layer messages.

$I_{PF}$  channel could be used either if the regular I service is  $I_P$ ,  $I_{PK}$  or  $I_{PQ}$ , and either if the service is provided with error correction ( $I_{P\_error\_correct}$ ) or error detection only ( $I_{P\_error\_detect}$ )

NOTE: The primary utility of the  $I_{PF}$  channel is the transmission of limited amount of U-plane data (i.e. acknowledgement messages) over the reverse bearer of asymmetric data connections.

#### 10.8.4.2 Activation of the E+U type mux mode

The B-field multiplexer enters in E+U mode due to the existence of signalling data (channels  $G_F$  and M) to be transmitted according to the priority rules defined in clause 6.2.2.4. The activation of the E+U mode has the consequence of closing the  $I_P$ ,  $I_{PK}$  or  $I_{PQ}$  channel over the bearer, and simultaneously opening a reduced rate  $I_{PF}$  channel using the spare capacity of the bearer.

The number of subfields used for U-plane data and C-plane signalling varies depending on modulation, slot type, and amount of signalling to be transported. The possible combinations are defined in clause 6.2.2.3.1.

At least one subfield with signalling should exist. Subfields transporting signalling shall precede subfields carrying  $I_{PF}$  channel data.

If there are not enough signalling messages plus  $I_{PF}$  channel segments to fill the slot, the slot shall be filled with the MAC message "NULL" (clause 7.3.3) repeated as many times as needed and placed at the end of the signalling subfields and before the  $I_{PF}$  channel segments.

Once the B-field mux enters in E+U mode, this mode is kept until the end of C-plane transmission, and until the total transmission of a complete MAC U-plane packet (equivalent to a DLC PDU). When there is no reason to keep the E+U type mode, the slot passes to U-mode with the MAC service in use.

The E+U type mux mode is indicated by the code "110" in the B-field identification bits (BA header) in A-field. The code "111" is also used if MAC service is  $I_{P\_error\_correct}$ .

NOTE: It not possible to use E+U mux type for transmission of  $C_F$  higher layer signalling channel.

#### 10.8.4.3 $I_{PF}$ procedures

$I_{PF}$  channel uses specific procedures in order to adapt the size of the standard MAC packet (equivalent to the DLC PDU) to the reduced and variable size of the E+U slot U plane subfields. There are two sets of procedures. Basic and advanced. Basic procedures guarantee  $I_{PF}$  channel operation. Advanced procedures increases efficiency in usage of all available subfields in the slot.

##### 10.8.4.3.1 $I_{PF}$ basic procedures

Basic procedures allow the transportation of a single segment of MAC packet (DLC PDU) in each E+U type slot. The transmitter side segments the packet according to the available U-plane subfields. However, if the PDU contains filling area (the SDU ends before the end of the PDU), the transmitter side may remove the padding bits, by placing a special code in the signalling control message described later in this clause.

The following cases could happen:

- Case 1: The slot carries the first part of a MAC packet (DLC PDU).
- Case 2: The slot carries the first and only part of a MAC packet (DLC PDU).

NOTE 1: Case 2 can only happen due to the padding removal option described above.

- Case 3: The slot carries the  $n^{\text{th}}$  part, but not the last, of a MAC packet (DLC PDU).

- Case 4: The slot carries the  $n^{\text{th}}$  and last part of a MAC packet (DLC PDU).

NOTE 2: In 2-level modulation, double or long slots, with the expected signalling needs, cases 1, 2 and 4 will happen with relative probability, while case 3 will be rare.

NOTE 3: In the reverse channel of asymmetric connections carrying Internet Protocol (IP), case 2 will happen with high probability due to the relatively short TCP acknowledgement packets.

In cases 1 and 2, the slot shall carry at least one  $G_F$  channel packet or "NULL and  $I_{PF}$  segmentation info" message. If no  $G_F$  channel packet is to be transmitted, then a message "NULL or  $I_{PF}$  segmentation info" shall be inserted in one of the signalling subfields of the slot.

In cases 3 and 4, a message "NULL or  $I_{PF}$  segmentation info" shall be, in any case, inserted in one of the signalling subfields (see clause 7.3.3).

The NCF field of the  $G_F$  or "NULL or  $I_{PF}$  segmentation info" shall carry the following codes:

|              |        |                                                        |
|--------------|--------|--------------------------------------------------------|
| Case 1       | "1010" |                                                        |
| Case 2       | "1011" |                                                        |
| Cases 3 or 4 | "1100" | only in a "NULL or $I_{PF}$ segmentation info" message |

In cases 1 or 2, if the NCF header is in a "NULL or  $I_{PF}$  segmentation info" message, the content of the "segmentation info" field in the message is irrelevant.

In cases 3 and 4, only, the octets 1, 2 and 3 of the "segmentation info" field in the "NULL or  $I_{PF}$  segmentation info" shall be written by the transmitter and shall be analyzed by the receiver. The meaning of such octets is defined in clause 7.3.3.1. By analysing this information, the receiver side could reconstruct the original MAC packet (DLC PDU).

In all cases, the PDU segment shall start in the first U-mode subfield in the slot. Note that there could be unused space at the end of the U-type area.

#### 10.8.4.3.2 $I_{PF}$ advanced procedures

Advanced procedures add the possibility to have two PDU segments (two segments belonging to two consecutive DLC PDUs) in the same E+U mux slot. The number of possible cases is increased. In turn of that, the E+U slots can be filled more efficiently.

In order to implement advanced procedures, the bit  $bn27$  in octet 2 and the octets 4, 5 and 6 in the "NULL or  $I_{PF}$  segmentation info" message shall be filled by the transmitter and analyzed by the receiver. The two segments of PDUs shall be packet one after the other, starting in the first U-mode subfield in the slot. There could be unused space at the end of the U-type area.

NOTE: The maximum number of PDU segments in a single slot is limited to two.

#### 10.8.4.3.3 Special case: slots not multiple of 64 bits

In some rare cases, the MAC packet size (DLC PDU size) of the  $I_P$ ,  $I_{PF}$  or  $I_{PQ}$  slot is not a multiple of 64 bits. This happens for instance in long slot 640  $I_{PQ}$  mode.

If the MAC packet size is not a multiple of 64 bits, it shall first be filled to the next 64 bits multiple, and then the normal  $I_{PF}$  procedures shall be used. The receiver side shall remove the padding bits before delivering the packet to higher layers.

NOTE: In this case, the number of padding bits is a constant well-known to both peers.

#### 10.8.4.4 $I_{PF}$ Mod-2 protected operation

The  $I_{PF}$  channel inherits the behaviour of the regular  $I_P$ ,  $I_{PF}$  or  $I_{PQ}$  U-plane MAC service. If the MAC service is "error\_correct" then the  $I_{PF}$  channel shall operate also in "error correction mode".

The  $I_{PF}$  channel also inherits the value of the "MAC lifetime" parameter used in the regular U-plane service.

The operation of the  $I_{PF}$  channel in error correct mode shall use the same procedure as the  $I_P$ ,  $I_{PF}$  or  $I_{PQ}$  channel (clause 10.8.2), with the following specific provisions:

- 3) The series of E+U type slots shall be an independent MOD-2 sequence, different of the sequence of  $I_{P\_error\_correct}$  slots transmitted before or after the E+U mode.
- 4) From the point of view of the main  $I_{P\_error}$  correct sequence, the insertion of E+U slots produces an  $I_P$  bearer reset (see clause 10.8.2.5.3).
- 5) If there were  $I_P$  packets pending for retransmission when the slot changes to E+U type mode, the transmitter side could, at its choice, reschedule the packet in the  $I_P$  channel of other bearer (if available), or pass the packet to the new  $I_{PF}$  channel. However, the "MAC lifetime" counter should be passed with the proper value.
- 6) The E+U slots shall be MOD-2 numbered by using, alternatively, the BA codes "110" and "111" (see table 7.2 in clause 7.1.4).
- 7) The MOD-2 receiver may use selective reception for building all subfields in the E+U slot.
- 8) The  $G_F$  channel and the "NULL or  $I_{PF}$  segmentation control" message, when NCF indicates any type of segmentation control, shall be always retransmitted together with U plane subfields.
- 9) The bearer quality message "MAC-MOD-2-ACK" shall never be retransmitted. Instead of them, a "fresh" message shall always be placed in the same subfield.
- 10) The retransmission or not of other MAC messages is free to the implementor. It is allowed to insert new MAC messages (or NULL) in these subfields when slot is retransmitted.
- 11) The insertion of an "all MAC control" (E-type, codes 110 or 111) field does not break the MOD-2 sequence. In this case the BA code 110 or 111 shall be used according to the sequence and the retransmission behaviour shall be as described in this clause.

NOTE: This is the only case when the BA code 111 could be used for an E-type "all MAC control or  $G_F$ " slot.

- 12) However, if the E/U mux has to switch to "E-type mux,  $C_F$  only" or "E-type mux with  $C_F$ " (BA codes 010, 011, 100 or 101), this breaks the sequence, and the numbering and retransmission of the slot shall be ruled by the  $C_F$  channel rules (clause 10.8.1.2).
- 13) In case of multibearer, it is allowed to retransmit a badly received bearer over another E+U type bearer. However, the packet lifetime counter shall be passed to new bearer with the proper value. This operation causes an "jump" (see clause 10.8.2) for the first bearer.

#### 10.8.4.5 $I_{PF\_error\_detect}$ operation

When the regular MAC service is  $I_P$  (or  $I_{PQ}$ ) error detect, the  $I_{PF}$  channel shall operate without retransmission, however with CRC error detection capability. In such cases, only the B-field (BA) code "110" shall be used. There shall not be MAC retransmission of any channel in E+U type slots.

#### 10.8.4.6 $I_{PF\_operation}$ with $I_N$ service

When the regular MAC service is  $I_N$ , the  $I_{PF}$  channel shall operate without retransmission, with the same format and procedures as for  $I_{P\_error\_detect}$ . However, packets shall be assembled at the receiver side, even in the case of CRC error of individual  $I_{PF}$  subfields. The CRC of A-field should be, however, correct to accept a packet. Segmentation info should be also received with correct CRC.

### 10.8.4.7 Backcompatibility rule

The support of I<sub>PF</sub> channel and E+U-type mux by PT or FT shall be indicated by a flag in the <Terminal capability> Information Element (see EN 300 175-5 [5], clause 7.7.41) and in "Extended higher layer capabilities (part 2)" broadcast (see EN 300 175-5 [5], clause F.3). This flag indicates the support of both, channel I<sub>PF</sub> and E+U-type mux mode.

The transmitter side shall not set E+U-type mux mode if the receiver side does not support I<sub>PF</sub> channel.

NOTE: However, the transmitter side may use the BA code "110" for transmission of E-type, all MAC control mux mode.

## 10.9 C/O procedures for FT connections with CRFP

The following procedures provide means to address CRFPs on one physical relayed connection of an FT with a PT. The connection with the PT is either in relay state or local state. In relay state, all higher layer C-plane signalling shall be relayed by the CRFPs between FT and PT. In local state, all higher layer C-plane signalling shall be buffered at the FT and CRFP. The local state is a temporary state to allow higher layer communication between FT and a specific CRFP. The procedures defined in this clause are required to support encryption of connections relayed by a CRFP.

### 10.9.1 Dual C/O bearer setup

#### At FT:

Initially a bearer will be established between the FT and CRFP (identified by its PMID). The FT regards the CRFP initially as a PT. A relayed bearer setup as defined below can only be accepted at the FT when a barer to the CRFP already exists. By definition the FT is then in the local state.

A relayed bearer setup, indicated by the "bearer\_request" without the "first PT transmission" code, shall be treated at the FT as a request from a CRFP. The TBC shall request the LLME to be connected to the MBC related to the PMID (of the PT) received in the message. Then the connection setup procedure as defined in clause 10.2 shall continue. The FT is now establishing the connection via the CRFP with the PT identified by the PMID. When the first bearer of the connection with the PT is established, the connection shall automatically enter the relay state.

At the FT both relayed and local mode connections have been established on one physical connection. However only one of these connections shall be active at the same time, and the other connection is suspended.

### 10.9.2 C/O connection release of connection with CRFP

When the MBC related to a PT is released, the FT shall release all MBCs associated with the corresponding TBCs.

### 10.9.3 C/O connection suspend and resume

Modification of the state of the connection with a CRFP after the connection is established, can be accomplished by suspending/resuming connections with the related MBC's in FT and CRFP. This procedure may be necessary to update cipher keys in the CRFP.

#### At FT:

To support the communication with a specific CRFP, the FT shall be able to address a specific CRFP identified by the PMID on one physical MAC connection. The FT shall be able to temporarily suspend the connection with the PT.

The LLME at the FT shall decide to change the connection of a TBC from one MBC (MBC<sub>1</sub>) to another MBC (MBC<sub>2</sub>), that is suspended. First the LLME shall suspend the connection of MBC<sub>1</sub> for transmission and resume connection of MBC<sub>2</sub> for transmission. The MBC<sub>1</sub> shall still receive channel data. The MBC<sub>2</sub> then issues the called address (FMID/PMID) to the TBC. The TBC shall transmit an "access\_request" on the active TBC with the "normal MT transmit" code.

When the TBC receives "bearer\_confirm" the TBC shall report to the MBC<sub>2</sub> that the switch is successfully established, which immediately (next frame) resumes the connection with MBC<sub>2</sub> for reception and suspends the connection with MBC<sub>1</sub> for reception.

In case of a basic connection, the access request and bearer confirm messages belong to the basic connection control set and in case of an advanced connection, the access request and bearer\_confirm messages belong to the basic connection control set.

NOTE: This procedure can be used for single bearer connections and multi bearer connections. Furthermore it supports all  $I_N$  and  $I_P$  channels.

---

## 11 Medium access layer management procedures

### 11.1 Broadcasting

#### 11.1.1 RFP transmission

The DECT fixed part's management entity makes all the N and Q channel information available to the BMC by means of a MAC\_ME\_RFP\_PRELOAD-req primitive (see clause 8.3.2.1). The LLME may update this information at any time. This primitive is used to give the MAC layer the SARI messages (see clause 7.2.3.6).

#### 11.1.2 PP reception

The MAC layer of the PP passes Q and N logical channel information to the LLME by means of a MAC\_ME\_INFO-ind primitive. If necessary, the LLME responds with a MAC\_ME\_INFO-res primitive (see clause 8.3.2.3).

The PP shall understand and comply with all Q channel information that is needed for the service that the PP requires. For example, a PP that requires an RFP to supply it with frequency control information, shall check that the RFP provides this capability before attempting to establish a connection with it.

### 11.2 Extended system information

#### 11.2.1 PP requests

The PP may use this facility to submit its ARI(s) for checking by the RFP in its TARI list. The procedure is invoked by the LLME passing a MAC\_ME\_EXT-req primitive (see clause 8.3.2.4) to the MAC layer. When the MAC layer has received a reply from the RFP, it issues a MAC\_ME\_EXT-cfm primitive (see clause 8.3.2.4) containing the SDU.

#### 11.2.2 RFP response

An RFP of an FP that provides the extended system information service shall issue a MAC\_ME\_EXT-ind primitive to the LLME after receiving an extended system information request. The LLME may return a reply with a MAC\_ME\_EXT-res primitive. Data delivered within this primitive shall be transmitted within T206 frames after receiving the extended system information request.

### 11.3 PP states and state transitions

Refer to figure 4.7 for PP states and transitions.

#### 11.3.1 Actions in Idle\_Unlocked and Active\_Unlocked states

In the Idle\_Unlocked state, a PP need not do anything.

In the Active\_Unlocked state, PPs occasionally try and enter the Idle\_Locked state (see clause 11.3.2).

A PP may change between the Idle\_Unlocked and the Active\_Unlocked state as it wishes.



### 11.3.2 Entry into the Idle\_Locked state

An Active\_Unlocked PP occasionally scans for a DECT fixed part with which it can enter the Idle\_Locked state. The timing of the start and end of this scan are controlled by the management entity which should consider such things as power consumption and SARI list length.

NOTE: The primitives PL-ME-SYNC, PL-RX, PL-ME-SIG\_STR are described in clauses 7.1 and 7.2 of the DECT physical layer (see EN 300 175-2 [2]).

The scan can be achieved using PL\_ME\_SYNC primitives to obtain slot timing and PL\_RX primitives to obtain N and Q channel information. The Q channel information allows frame, multi-frame, and receiver scan synchronization to be obtained.

The PP uses a MAC\_ME\_INFO-ind primitive to pass a PARI or a SARI to the management entity. The management entity issues a MAC\_ME\_INFO-res containing the PARI only if it identifies an acceptable ARI.

The PP should then use PL\_ME\_SIG\_STR and PL\_RX primitives to select the RFP (that transmits the above PARI) with the strongest signal strength.

If the PP wishes to enter the Idle\_Locked state it shall extract all the transmitted  $Q_T$  information that is necessary for all the MAC and physical layer service types that it can use.

EXAMPLE: If a PP can implement encryption and only B-field connection setups, it has to receive the "multiframe number" and the "fixed part capabilities" messages.

After this  $Q_T$  information has been obtained, the PP may enter the Idle\_Locked state.

### 11.3.3 Actions in the Idle\_Locked state

In the Idle\_Locked state, the PP shall maintain frame and multiframe synchronism with the FP and may occasionally scan for RFPs with a stronger signal strength. If a stronger RFP is found, then the PP may lock to this RFP instead. In addition the PP should be able to receive paging messages and may provide the means to detect connection setup attempts from the FP (fast setup).

In order to remain in the Idle\_Locked state the PP shall:

- resynchronize its timing with the FP's timing at least every  $T_{216}$  multiframe (see EN 300 175-2 [2]);
- receive in frame 0 at least one A-field with correct CRC every  $T_{207}$  seconds; and
- receive at least one  $N_T$  type tail containing the PARI in the MAC\_ME\_INFO-res primitive every  $T_{208}$  seconds.

If any of these conditions are not met, the PP shall enter either the Active\_Unlocked state or the Idle\_Unlocked state.

At any time an Idle\_Locked PP may leave this state and enter either the Active\_Unlocked state or the Idle\_Unlocked state.

#### 11.3.3.1 Page detection in Idle\_Locked state

In Idle\_Locked state the PP should receive the  $B_S$  channel. To provide this function three typical modes of operation for an Idle\_Locked PP are described below.

**High duty cycle Idle\_Locked mode:** the PP receives all  $B_S$  channel data that is transmitted in frames 0, 2, 4, 6, 10 and 12 of the multiframe sequence. High duty cycle Idle\_Locked mode enables a PP to receive fast pages (see clause 9.1.3).

NOTE 1: Higher layer functions are used to ascertain whether a PP is likely to respond to fast paging (see EN 300 175-5 [5]).

**Normal Idle\_Locked mode:** the PP at least receives any  $B_S$  channel data transmitted in frame 0 and in any additional frames that are commanded by the extend flag.

**Low duty cycle Idle\_Locked mode:** in at least one out of every four multiframes the PP shall attempt to receive any  $B_S$  channel data transmitted in frame 0 and in any additional frames that are commanded by the extend flag. Unless the FP broadcasts that low duty Idle\_Locked mode is supported (see "page repetition bit" in "fixed part capabilities", clause 7.2.3.4) the PP shall not enter this mode.

NOTE 2: PPs in low duty cycle Idle\_Locked mode do normally not receive long page messages which are used by higher layers for connectionless downlink services.

### 11.3.3.2 Setup detection in Idle\_Locked state

PPs may allow FPs to setup a connection without prior paging. This process is called fast setup and described in clause 10.2.3.

NOTE 1: Higher layer functions are used to ascertain whether a PP is likely to respond to fast setups attempts.

There are two modes of operation of the Idle\_Locked state with setup detection:

**Idle\_Locked state with Complete setup detection:** the PP scans all downlink slots of frame looking for a "bearer request" message containing its own PMID.

**Idle\_Locked state with Selective setup detection:** the PP scans only one or two slots of the frame looking for a "bearer request" message containing its own PMID.

NOTE 2: The FT setup attempt can be either A-field or B-field depending of the usable modes in the application profile.

NOTE 3: If B-field setup is used, the profile specification could mandate that the setup command is in a specific sub-field of the slot.

For both modes, the PP's receiver scan sequence shall be synchronized with that of the RFP (see clause 11.9). Depending on the mode, it receives in every downlink slot, or on one or two slots, on the scanned RF channel looking for a "bearer request" message containing its own PMID.

NOTE 4: The RFPs do not indicate the first transmission with a special TA header coding (see clause 10.5.1.3). The TA header code will be 100 in case of A-field setup, or could be any valid code in the case of B-field setup.

For selective mode, the following sub-modes are allowed:

- SEL 1: The PP receives only in one slot (slot N);
- SEL 2: The PP receives in two slots: slot N and slot N+6 (or N-6 if N>6);
- SEL 2B: The PP receives in two slots: slot N and slot N+2 (or N-2 if N>10).

The control of the setup mode, and the slot (N value), if applicable, may be done by means of the following mechanisms:

- 1) The "MAC Resume and control page" broadcast command, clause 7.2.4.1.4.
- 2) By means of the reason code in the message "release" used to drop the last bearer of the connection. The message carries also information on the slot(s) to be kept in listen for setup mode. In the case of A-field signalling (see clause 7.2.5.3.13), only the complete or SEL 1 modes may be activated. In the case of B-field signalling (see clause 7.3.2.10), all modes may be activated.
- 3) The slot(s) number may also be transmitted by means of the channel list command "LISTEN" in one of the last two frames before the release. In this specific case, it is also possible to transmit the channel number to be used. The value "11111" in the CN field shall be understood as the standard fast setup scan sequence.

NOTE 5: The command "MAC Resume page", broadcasted when in listen for setup mode, may be used, if needed, to change the slots/channels selected by the LISTEN command.

NOTE 6: The profile specification could establish other conventions for applicable mode and slot.

When the PP is in any mode of Idle\_locked with setup detection state, it shall also be in high duty cycle paging detection mode.

### 11.3.4 Idle\_Locked and Active\_Locked state transitions

Entry into the Active\_Locked state can only be achieved from the Idle\_Locked state. This transition is achieved by the establishment of a connection, as described in clause 10.2 or by the resumption of a connection.

When an Active\_Locked PP releases its last existing connection or suspends its last connection in "active state", it shall return to the Idle\_Locked state.

## 11.4 Physical channel selection

The physical channel selected for a MAC bearer is only allowed to be changed due to a detected need to change it. Typical needs are detection of bad quality or interference on the physical channel in use, detection of an RFP that is stronger than the own RFP, detection of a physical channel with less interference than the one in use, and detection of local congestion.

### 11.4.1 The channel selection lists

Prior to the first transmission on any bearer DECT RFPs and PPs have to select physical channels. To find appropriate channels the channels shall be ordered according to the measured field strength.

The term "channel" refers to the relevant physical channel of a TDD pair (i.e. two time slots using the same frequency, and starting points of the time slots are separated by 0,5 frame). The RSSI measurement in the relevant physical channel determines the selection performance for one or both physical channels of a TDD pair. The choice of the relevant physical channel of a TDD pair depends on the wanted bearer type.

a) **Duplex bearer:**

- for a duplex bearer the relevant physical channel is *either*, the receiving physical channel, e.g. for a PP the RSSI measurement in slot 3 on frequency  $f_x$  defines the selection performance to use slot pair (3/15) on this frequency as a duplex bearer, *or* that channel of the TDD pair with the higher measured field strength, e.g. for a PP the higher of the RSSI values measured in slots 3 and 15 on frequency  $f_x$  defines the selection performance to use slot pair (3/15) on this frequency as a duplex bearer.

b) **Double simplex bearer:**

- for a double simplex bearer the relevant physical channel is that channel of the TDD pair with the higher measured field strength, e.g. for a PP the higher of the RSSI values measured in slots 3 and 15 on frequency  $f_x$  defines the selection performance to use slot pair (3/15) on this frequency as a double simplex uplink bearer.

c) **Simplex bearer:**

- for a simplex bearer the relevant physical channel in the transmitter is different for PPs and RFPs. For PPs it is *either*, the receiving TDD half of the desired physical channel, e.g. the RSSI measurement in slot 3 on frequency  $f_x$  defines the selection performance to use slot 15 on this frequency as an uplink simplex bearer, *or* that channel of the TDD pair with the higher measured field strength, e.g. the higher of the RSSI values measured in slots 3 and 15 on frequency  $f_x$  defines the selection performance to use slot 15 on this frequency as an uplink. For RFPs it is that channel of the TDD pair with the higher measured field strength.

Table 11.1

| Wanted bearer type | Relevant physical channel of the TDD pair                                       |                                                                                 |
|--------------------|---------------------------------------------------------------------------------|---------------------------------------------------------------------------------|
|                    | Selection by a PP                                                               | Selection by an RFP                                                             |
| duplex             | channel in normal receiving TDD half frame or channel with higher measured RSSI | channel in normal receiving TDD half frame or channel with higher measured RSSI |
| simplex            | channel in normal receiving TDD half frame or channel with higher measured RSSI | channel with higher measured RSSI                                               |
| double simplex     | channel with higher measured RSSI                                               | channel with higher measured RSSI                                               |

The resolution of the RSSI measurement shall be better than or equal to 6 dB as defined in EN 300 175-2 [2]. The lowest boundary shall be equal or less than -93 dBm. Channels with a measured RSSI of less than this lowest boundary are considered as quiet channels, and may be immediately selected for a bearer setup attempt. An upper limit may be defined where a channel is considered to be busy. Channels with a RSSI of more than this upper limit need not be ordered with a resolution of 6 dB, but these channels shall not be selected for a bearer setup attempt. Channels with a measured field strength which lies between these two boundaries shall be ordered according to the measured field strength into "n" bands. The RSSI difference of all channels within the same band shall not exceed 6 dB.

NOTE 1: The upper limit may be a variable which depends on the interference environment. Nevertheless the upper limit cannot exceed the highest field strength for which a receiver guarantees a RSSI measurement resolution of 6 dB.

The description above leads to the "n"-bandbin model, given in table 11.2.

Table 11.2: RSSI model

| RSSI      | $\sigma$ RSSI | band  | comment               |
|-----------|---------------|-------|-----------------------|
| > max dBm | $\infty$      | busy  | busy, do not try      |
|           | $\leq 6$ dB   | b(n)  | possible candidates   |
|           | .             | .     |                       |
|           | .             | .     |                       |
|           | $\leq 6$ dB   | b(4)  |                       |
|           | $\leq 6$ dB   | b(3)  |                       |
|           | $\leq 6$ dB   | b(2)  |                       |
|           | $\leq 6$ dB   | b(1)  |                       |
| < min dBm | $\infty$      | quiet | quiet, always allowed |

Depending on the wanted bearer type a basic channel list can be modelled where a quality assignment based on the measured RSSI exists for each TDD pair of physical channels, i.e. for each slot pair of each frequency. The quality assignment is either a band number (b(1) to b(n)), a "busy" sign or a "quiet" sign.

The basic channel list describes the overall DECT interference environment for a given upper limit "max" and does not depend on any system restrictions. It is not required that DECT equipments set-up a complete basic channel list. However, different slot types require different channel lists.

In reality there might exist channels which cannot be measured or used.

EXAMPLE 1: A DECT equipment may be unable to use slot pair (4/16) on frequency  $f_x$  having at the same time an established bearer on slot pair (3/15) and frequency  $f_y$ .

EXAMPLE 2: A DECT equipment may be unable to measure the RSSI in slot 15 and frequency  $f_x$  while having a bearer established in slot pair (3/15) and frequency  $f_y$ .

EXAMPLE 3: An RFP may not be allowed to support all 10 DECT frequencies.

A modified channel list shall therefore take into account all known restrictions. "busy" is used below as a general term for channels that shall not be used. A DECT equipment shall be able to create a modified channel list with following properties:

- a) all entries of own blind slots or blind TDD channel pairs shall be regarded as busy;

- b) not supported frequencies at the FP shall be regarded as busy.

NOTE 2: The information concerning frequencies that are not supported at the FP is broadcast by the FP with the static system information message (see clause 7.2.3.2).

The following deviations are allowed for the modified channel list:

- a) if all possible candidates are below the lower limit "min", the list of quiet channels does not need to be complete;
- b) the uppermost band of possible candidates (band b(n)) does not need to be complete, i.e. there might exist channels belonging to b(n) which are regarded as "busy". Nevertheless, the bands below the band b(n) as well as the list of quiet channels have to be complete.

NOTE 3: These two deviations allow the RFP or PP to only create a list of m candidate channels which are quiet and/or the quietest channels. Here the upper limit "max" is a variable and depends on the interference environment. All except the m quietest channels are regarded as "busy".

In addition further channels may be regarded as busy due to restrictions at the far end, e.g. received blind slot or POOR channel information.

NOTE 4: Blind slot information is temporary and specific for each RFP of an FP.

PPs should take into consideration a recognized connectionless downlink bearer or a dummy bearer of the locked RFP.

NOTE 5: The PP's RSSI measurement for the channel used by the RFP for the broadcast or connectionless service will normally lead to the decision not to select it. Nevertheless this channel may be the preferred channel for a new bearer, e.g. a connectionless uplink bearer or a duplex bearer when allowed (see fixed part capabilities, clause 7.2.3.4).

The maintenance of the modified channel list may be done regularly or upon need, subject to rules in clauses 11.4.2 and 11.4.3.

## 11.4.2 Physical channel and RFP selection at the PP

A PP shall be in a locked state (Idle\_Locked or Active\_Locked) before it may start transmission on a physical channel.

The initial set-up should be performed so as to always connect to the strongest possible RFP, and it shall use the signal strength values obtained with PL\_ME\_SIG\_STR primitives as a criteria. Therefore it is recommended to make at least 3 attempts to the strongest RFP before selecting the next strongest RFP.

The selection of physical channels shall be subject to all of the following rules:

- a) for a duplex bearer the TDD pair including the dummy bearer may only be selected when allowed (see clause 7.2.3.4);
- b) unless the selected channel has a measured RSSI that meets the "quiet" criterion (see clause 11.4.1), the complete modified channel list shall have been updated within the last T209 seconds;
- c) channels marked as "busy" shall not be selected;
- d) for bearer handover and for setting up the pilot channel of an  $I_{N\_normal\_delay}$  or an  $I_p$  service:
  - d1) if the quietest unselected channel is marked as "quiet": if none of the unselected quiet channels can be accessed within the next three TDMA frames, a channel of bands b(1) or b(2) may be selected; otherwise a quiet channel shall be selected for the next setup attempt;
  - d2) if the quietest unselected channel is in band b(x),  $x < (n-1)$ : If none of the unselected channels in band b(x) can be accessed within the next three TDMA frames, a channel of bands b(x + 1) or b(x + 2) may be selected; otherwise a channel of band b(x) shall be selected for the next setup attempt;
  - d3) if the quietest unselected channel is in band b(n-1): If none of the unselected channels in band b(n-1) can be accessed within the next three TDMA frames, a channel of band b(n) may be selected; otherwise a channel of band b(n-1) shall be selected for the next setup attempt;

- d4) if the quietest unselected channel is in the highest band  $b(n)$ : A channel in band  $b(n)$  shall be selected for the next setup attempt;
- e) for all other bearer establishments:
  - e1) unless all channels marked as "quiet" have been selected at least once, no channel of the bands  $b(1)$  to  $b(n)$  shall be selected;
  - e2) unless all channels of the bands  $b(1)$  to  $b(x-1)$  have been selected at least once, no channels of the band  $b(x)$  shall be selected;
- f) in any time window of  $T_{210}$  seconds the number of channel selections shall not exceed the value  $N_{202}$  multiplied by a factor which depends on the number of required bearers (see table 11.3).

The number of required duplex and double simplex bearers is calculated as the difference between the target number of bearers and the number of already established bearers at the beginning of the time interval.

**Table 11.3: Maximum number of selections**

| Number of required bearers | Maximum number of selections |
|----------------------------|------------------------------|
| 1                          | 1 x $N_{202}$                |
| 2 to 3                     | 2 x $N_{202}$                |
| 4 to 7                     | 3 x $N_{202}$                |
| 8 to 15                    | 4 x $N_{202}$                |
| > 15                       | 5 x $N_{202}$                |

NOTE 1: For uplink simplex bearers a lower limit is defined in clause 9.2.1.

NOTE 2: For multibearer connections a complete set of channels may be selected at the start of the connection establishment procedure using the channel selection rules. The parallel setup attempts of the multibearer connection may then use these selected channels in any order (for example the order of known receiver scanning and/or an order indicated by received channel list messages).

- g) unless a "GOOD" or a "LISTEN" channel list message or "acceptable channel" information is received a channel shall not be reselected for access to the same RFP until the modified channel list has been completely updated;
- h) a channel may only be selected if it is checked within the last 2 frames before the first transmission, and the RSSI shall not be more than 12 dB stronger than the previous value (checking channels: see clause 11.4.1);

EXAMPLE: Having made a RSSI measurement with a 6 dB resolution the channel may still be selected for a new bearer when it belongs to band  $b(x + 1)$ , assuming the channel was previously in band  $b(x)$ . The channel shall not be selected for a new bearer if it belongs to a band higher than  $b(x + 1)$ .

- i) the PP may use information from the RFP (e.g. "acceptable channel" or "channel list" information) to aid its choice of channel. Nevertheless, rules a) to h) shall not be violated.

NOTE 3: For simplex uplink bearers this selection procedure is only applied when no dummy or C/L downlink bearer has been found. Otherwise the TDD pair of this downlink bearer has to be chosen for the uplink (see clause 9.2.2).

In addition to these rules it is recommended not to use any channel pair for setting up a duplex or a double simplex bearer to a specific RFP when a C/L downlink or a dummy bearer of another RFP was recognized in the normal receive channel of the PP (slot 0 to 11).

It is allowed to use the PP channel selection rules for simplex bearers for setting up a dummy bearer when a PP acts as the RFP in PP-to-PP direct communication mode.

### 11.4.3 Physical channel selection at the RFP

For an FT initiated setup of an initial duplex bearer (fast setup) the RFP shall know the receiver scanning sequence of the PP before it may transmit a "bearer request" message on a physical channel.

For an FT initiated setup of additional duplex bearers, before it may transmit a "bearer request" message on a physical channel, the FT shall either:

- 1) have received one or more LISTEN commands from the PT, and use one of these channels for the setup;
- 2) have sent one or more START commands to the PT on any pre-existing duplex bearer, and use one of these channels for the setup;
- 3) in absence of LISTEN or START commands, the FT shall know the PT receiver scan sequence and shall use it.

For an FT initiated setup of double simplex downlink bearer (see clause 10.5.1.4), before it may transmit a "bearer request" message on a physical channel, the FT shall either:

- 1) have received one or more LISTEN commands from the PT, and use one of these channels for the setup;
- 2) have send one or more START commands to the PT on any pre-existing duplex bearer, and use one of these channels for the setup.

NOTE 1: Either START or LISTEN are mandatory when setting up double simplex bearers.

For the creation of a dummy bearer following the termination of all other bearers at an RFP, the RFP should select without interruption the channel previously occupied by the last active downlink bearer. The selection of physical channels in all other circumstances or if this recommendation is not followed shall be subject to all of the following rules:

- a) unless the selected channel has a measured RSSI that meets the "quiet" criterion (see clause 11.4.1), the complete modified channel list shall have been updated within the last T209 seconds;
- b) channels marked as "busy" shall not be selected;
- c) for setting up the pilot bearer and for bearer handover of a double simplex bearer when the RFP is in operation as the T-Side:
  - c1) if the quietest unselected channel is marked as "quiet". If none of the unselected quiet channels can be accessed within the next three TDMA frames, a channel of bands b(1) or b(2) may be selected; otherwise a quiet channel shall be selected for the next setup attempt;
  - c2) if the quietest unselected channel is in band b(x),  $x < (n-1)$ . If none of the unselected channels in band b(x) can be accessed within the next three TDMA frames, a channel of bands b(x + 1) or b(x + 2) may be selected; otherwise a channel of band b(x) shall be selected for the next setup attempt;
  - c3) if the quietest unselected channel is in band b(n-1). If none of the unselected channels in band b(n-1) can be accessed within the next three TDMA frames, a channel of band b(n) may be selected; otherwise a channel of band b(n-1) shall be selected for the next setup attempt;
  - c4) if the quietest unselected channel is in the highest band b(n). A channel in band b(n) shall be selected for the next setup attempt;
- d) for all other bearer establishments:
  - d1) unless all channels marked as "quiet" have been selected at least once, no channel of the bands b(1) to b(n) shall be selected;
  - d2) unless all channels of the bands b(1) to b(x-1) have been selected at least once, no channels of the band b(x) shall be selected;
- e) in any time window of T210 seconds the number of channel selections shall not exceed the value N202 multiplied by a factor which depends on the number of required bearers (see table 11.4);

The number of required double simplex bearers is calculated as the difference between the target number of bearers and the number of already established bearers at the beginning of the time interval.

**Table 11.4: Maximum number of selections**

| Number of required bearers | Maximum number of selections |
|----------------------------|------------------------------|
| 1                          | 1 x N202                     |
| 2 to 3                     | 2 x N202                     |
| 4 to 7                     | 3 x N202                     |
| 8 to 15                    | 4 x N202                     |
| > 15                       | 5 x N202                     |

NOTE 2: Setting up dummy or C/L downlink bearer needs only one selection. Therefore no limit for simplex downlink bearer is needed.

NOTE 3: For multibearer connections a complete set of channels may be selected at the start of the connection establishment procedure using the channel selection rules. The parallel setup attempts of the multibearer connection may then use these selected channels in any order (for example the order of known receiver scanning and/or an order indicated by received channel list messages).

- f) unless a GOOD or a LISTEN channel list message is received a channel shall not be reselected for access to the same PP until the modified channel list has been completely updated;
- g) a channel may only be selected if it is checked within the last 2 frames before the first transmission, and the RSSI shall not be more than 12 dB stronger than the previous value (checking channels: see clause 11.4.1);

EXAMPLE: Having made a RSSI measurement with a 6 dB resolution the channel may still be selected for a new bearer when it belongs to band  $b(x + 1)$ , assuming the channel was previously in band  $b(x)$ . The channel shall not be selected for a new bearer if it belongs to a band higher than  $b(x + 1)$ .

- h) the RFP may use information from the PP (e.g. CHANNEL\_LIST information) to aid its choice of channel. Nevertheless rules a) to g) shall not be violated.

In addition to these rules it is recommended not to use any channel pair for setting up any bearer when a C/L downlink or a dummy bearer of a neighbour RFP was recognized in the normal transmit channel of the RFP (slot 0 to 11).

#### 11.4.4 Hand over criteria due to in-connection base identification

Bearer and connection handover should be performed so as to always connect to the strongest (free) RFP, and it should use channel quality and shall use the signal strength values, the latter obtained using the procedure specified in EN 300 175-2 [2] as a criteria. Information from MAC "channel list" messages may also be used.

#### 11.4.5 Handover criteria due to interference

The handover decision process should be optimized to make a quick intra-cell handover when the DECT transmission suffers interference during a *few consecutive* frames. This is because most interference normally comes from DECT transmissions in the same band, and DECT transmissions will always occur in consecutive frames.

NOTE: Interference may also occur from systems allocated adjacent to the DECT band, UTRA/TDD above 1 900 MHz and GSM 1 800 MHz base station transmit band below 1 880 MHz. This Interference will occur during consecutive DECT frames if the interferer has a frame cycle time of  $10/N$  ms, where N is an integer, e.g. it is true for the UTRA TDD which has a 10 ms frame cycle time, but it is not true for GSM 1800 which has a frame cycle time of 60/13 ms, whereby a DECT time slot is interfered as seldom as every 6<sup>th</sup> frame by a single GSM bearer. It is advised that the DECT handover procedure is implemented to also enable a successful handover when the up-link or the down-link is interfered as seldom as every 6<sup>th</sup> frame. An example of handover criteria for such an implementation (for speech) is:

- Indicted errors of a slot: Sync. failure, A-CRC, X-CRC, sliding collision. One or more of these errors in the same slot indicated as a slot error.
- Relevant slots: Up-link and Down-link. Up-link slot error is reported to the PP in the following down-link by proper Q-bit setting. The PP gives the same weight to slot error in up- and down-links.



- The PP has a "leaking bucket" procedure to trigger handover when the bucket is empty (0). Max content is 32 (overflow limit), empty is 0. Start setting is 16. Correct slot adds one. Error slot subtracts 8.

This example gives 30 ms to 40 ms trigger time for interference from DECT or UMTS/TDD and 480 ms to 540 ms for interference from a single GSM bearer. If wanted it is possible to add an extra criteria to further decrease the trigger time for interference on consecutive DECT frames (interference from DECT).

## 11.4.6 Exception in channel selection rules for Ultra Low Energy devices

For DECT Ultra Low Energy devices the requirements given in clause 11.12 shall apply. DECT ULE PPs implementing all mandatory requirements given in clause 11.12 are exempt to follow the channel selection rules described in the present clause 11.4 when performing bearer setups using expedited procedures (messages Expedited Access Request or Expedited Access Request Ready for Release).

## 11.5 In-connection quality control

### 11.5.1 RFPI handshake

A radio endpoint shall release a bearer if it has not received the correct RFPI with a correct CRC on that bearer in the last T201 seconds.

### 11.5.2 Frequency control

#### 11.5.2.1 RFP measurement of frequency error

Provided the RFP supports frequency control the frequency error of the received physical packets is reported in the PL\_RX-cfm primitive. If the frequency error is too large (when averaged over a suitably long time) a frequency control request is sent to the PT (see clauses 7.2.5.5 and 7.3.4).

If the RFP receives a frequency control reject message, it shall not send any more frequency control message to that PT.

#### 11.5.2.2 PT frequency correction

When a frequency control request message is received by the MAC layer in the PT, it sends an appropriate PL\_FREQ\_ADJ-req primitive to its physical layer.

In response to a PL\_FREQ\_ADJ-req primitive the Physical layer may issue a PL\_FREQ\_ADJ-cfm primitive, indicating that frequency control is not supported. A PP's MAC layer receiving this primitive may send a frequency reject message to the requesting RFP.

## 11.6 Maximum allowed system load at RFPs

In any frame the maximum capacity occupied by traffic bearers at an RFP shall not exceed 14,4 half slots per TDMA frame, multiplied by the number of RF channels available to the DECT system, as regulated by the national authorities.

NOTE: One half slot traffic bearer occupies two half slots; one full slot traffic bearer occupies four half slot; one long slot ( $j=640$  or  $j=672$ ) or one double slot traffic bearer occupies eight half slots.

## 11.7 PMID and FMID definitions

### 11.7.1 FMID definition

The FMID is supplied to the MAC layer by the management entity and is defined in EN 300 175-6 [6].

## 11.7.2 PMID definition

The PMID is supplied to the MAC layer by the management entity and is defined in EN 300 175-6 [6].

### 11.7.2.1 'X'PMID definition

The 'X'PMID (shortened PMID) is defined as the 12 least significant bits of the PMID. It is used in some messages of the advanced control part 2 set (see clause 7.2.5.12.3).

## 11.8 RFP idle receiver scan sequence

In every slot a receiver in an RFP is either **active**, or **scanning**, or **idling**.

The receiver is **active** if it is receiving a traffic or connectionless bearer used by that RFP.

**Scanning** is when the receiver is listening for bearer set-up attempts on physical channels. If the receiver is **active** on a particular slot, it will be unable to **listen** in that slot on a different RF carrier (however, an RFP may have more than one receiver).

**Idle** is a non-preferred state. It implies that the RFP is not scanning for any (more) bearer set-up attempts. Receivers are (almost automatically) idle when the RFP transmits.

All RFPs within a DECT internal handover area (see EN 300 175-6 [6]) shall operate on the same set of RF carriers.

The **primary scan** is defined as the scan that is maintained if the RFP has one or more receiver(s) free. If the RFP has more than one receiver free, it maintains **secondary** and **tertiary** scans that lag behind the **primary scan**.

All RFPs within a DECT internal handover area (see EN 300 175-6 [6]) shall have their **primary scans** on the same RF carrier at the same time.

If different systems are synchronized (e.g. via the synchronization port), it is recommended that at any given time, the **primary scans** of these systems are on different RF carriers.

When RFPs scan the physical channels they shall do so in the order described below.

By the **primary scan** all available RF carriers shall be scanned sequentially at a rate of 1 carrier per TDMA frame. RF carriers shall be scanned in order of ascending carrier numbers.

After scanning the highest numbered available RF carrier, the receiver re-starts the **primary scan** in the following TDMA frame on the lowest numbered available carrier.

An RFP shall listen to all slots in which a PP transmission on a new bearer can be accepted.

NOTE: An RFP receiver of an FP that does not support asymmetric connections may be idle during slots 0 to 11. These are the normal RFP transmit slots.

The RFP uses the  $Q_T$  messages to broadcast on which RF carrier its primary scan will be in the next frame. These messages also give the number of transceivers at the RFP (thus giving an indication of whether a secondary or tertiary scan exists) and the number of RF carriers that exist.

Secondary receiver scan lags behind the **primary** receiver scan by 6 TDMA frames.

The tertiary receiver scan lags behind the **primary** receiver scan by 3 TDMA frames.

The operation of any additional **idle** receiver(s) is not defined.

Broadcast blind slot information should reflect the primary receiver scan sequence (see clause 7.2.4.3.3).

In order to optimize system performance for multiple transceiver RFPs, the RFPs should maintain active bearers in the following order of preference:

- a) on any available transceiver without an active receiver scan in operation;
- b) on the transceiver with the tertiary receiver scan;

- c) on the transceiver with the secondary receiver scan;
- d) on the transceiver with the primary receiver scan.

An RFP that has an extended frequency allocation and uses one or more of the basic DECT frequencies shall transmit "static\_system\_information" with a PSCN set equal to one of the basic DECT frequencies at least once every 32 multiframe. Furthermore, the "extended\_RF\_carriers" message shall contain the number of RF carriers being scanned at that RFP.

## 11.9 PT receiver scan sequence

For FT initiated setup of initial duplex bearers (fast setup), the PT shall arrange its receiver scanning sequence such that it scans the same sequence of channels as the chosen RFP primary scan (see clause 11.8), lead by one frame (see figure 11.1). This sequence is called "Fast setup scan sequence".

For FT initiated setup of additional duplex bearers (multibearer connections), the setup can be performed in the same way (on the PT fast setup scan sequence), or on any channel by using the channel list commands LISTEN (sent by the PT) or START (sent by the FT).

The PT scan sequence should lead the RFP (primary) scan by one frame, as shown in figure 11.1.

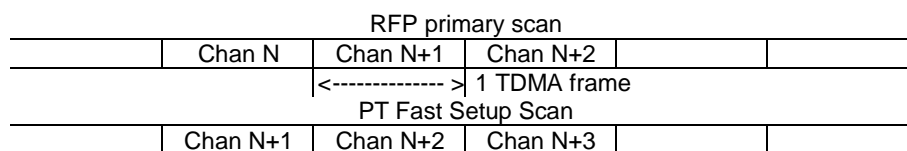

**Figure 11.1: PT receiver scan sequence**

## 11.10 Management of connections associated with Broadband data links

A Broadband data link can comprise up to three MAC connections. From MAC layer point of view these connections shall be seen as independent connections in the sense that all elements and procedures defined in the present document, e.g. connection setup, release and handover, one pilot bearer per connections, messages, etc. shall apply. The only exception from this rule is the assignment of the ECNs of the second and third connection which need to be agreed beforehand during NWK layer message exchange.

NOTE 1: There is no MAC messages exchange mechanism defined for indication if a connection belongs to a Broadband data link or not.

The LLME is responsible for the management of connections associated with one Broadband data link. In particular LLME should monitor the data buffers in DLC layer and depending on the demand for data transmission, and in accordance with the agreed min/max number of bearers, LLME should maintain, suspend or resume the involved connections and add or release bearers.

NOTE 2: The LLME may maintain for each Broadband data link a channel allocation table. The table may include information on the link's negotiated bandwidth values (i.e. max and minimum simplex bearers in each direction), the number of active MBCs (i.e. active connections and their ECNs) and the number of active bearers per MBC (including those under setup).

NOTE 3: There may be implementations that utilize multiple transceivers. Such implementations may need to maintain track which transceiver with each particular bearer is involved. A connection in such implementations may comprise bearers that are maintained on different transceivers.

## 11.11 Management procedures for "no-emission" mode

This clause defines the management procedures, which are required for the operation of the "no-emission" mode.

### 11.11.1 Behaviour during "no-emission" mode

In "no-emission"-mode, all PTs and the FT are scanning the preferred carrier for a system-member to get active.

The FT should scan at least every  $N211/2$  frames.

PTs may scan only for a short time in order to optimize the standby-time. The PT scan interval shall be no more than  $N210/2$  frames, to ensure that the PT has the possibility to scan at least 2 times during an FT-DummyPointer-phase.

## 11.12 Physical channel selection procedures for DECT Ultra Low Energy (ULE)

### 11.12.1 General

The standard DECT channel selection algorithm, as described in clause 11.4, requires the PP to routinely scan the available DECT channels in order to build the channel list. For applications where the main requirement is the reduction of power consumption by PPs under low or moderate traffic conditions, such as DECT ULE, an alternative channel selection strategy shall be used.

The procedures described in the present clause shall be used by all Portable Parts compliant with DECT ULE (TS 102 939 parts 1 [i.10] and further parts of the same multi part deliverable) when performing ULE packet data bearer setups using "expedited" procedures (see clause 10.5.1.8 in the present document).

The ULE channel selection strategy is based on a channel pre-selection by the RFP, which is the part that performs the routinely channel scan, combined with a PP algorithm (process M1) that executes a random process combined with a last minute channel verification. An additional PP algorithm (process M2) will be in charge of properly handling potential collision cases.

ULE PPs may also temporarily use the procedures described in clause 11.4 when performing channel selection for setups of voice calls, service calls, initial registration or exceptional operations. However, they are not expected to do that in normal operation mode.

### 11.12.2 Overall architecture of ULE channel selection processes

The overall architecture of the DECT ULE channel selection processes is depicted in figure 11.2.

The following processes and elements are identified:

- **Process M0:** It is the channel pre-selection process to be done by the RFP
- **Broadcast mechanism:** it is the mechanism for broadcast of channel selection information over the ULE dummy bearer
- **Process M1:** it is the general algorithm to be executed by the PP in normal channel selection cases
- **Process M2:** it is the collision handling (collision avoidance) algorithm to be executed by the PP after an access failure that may be the result of an access collision.

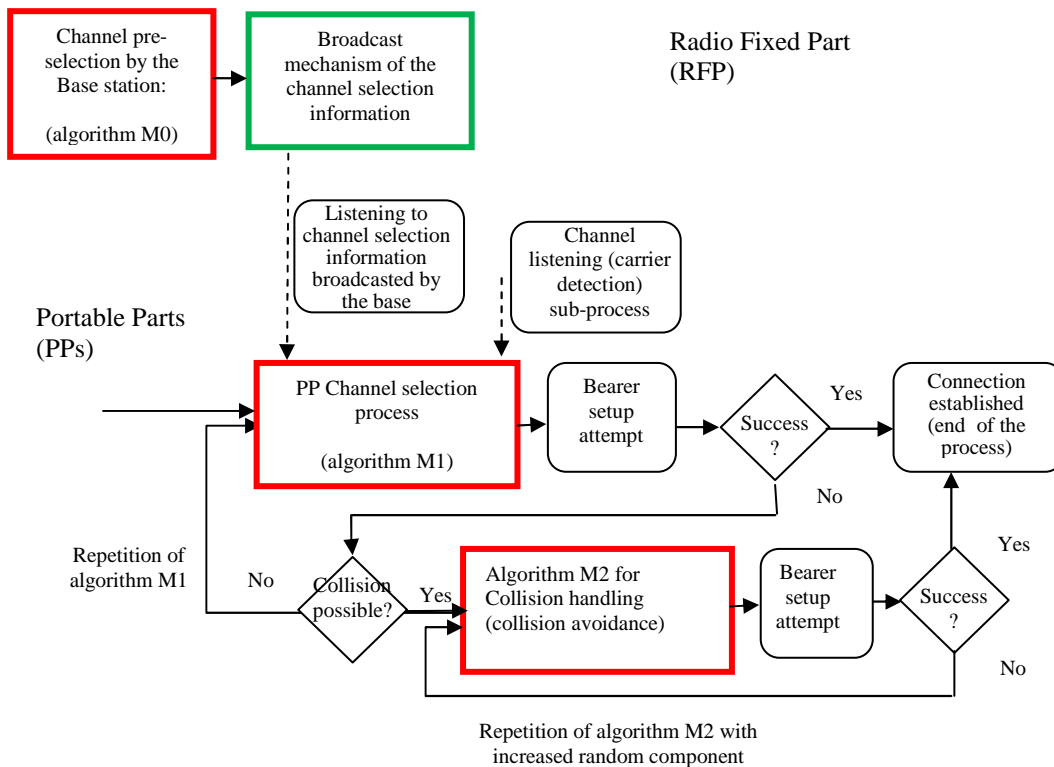

**Figure 11.2: Overall architecture of ULE Channel Selection Processes**

### 11.12.3 Process M0 (RFP side pre-selection process)

The process M0 is the RFP side channel pre-selection process. The RFP scans channels and prepares a list of candidate channels/slots to be used for setup in frame  $N+m$ , which is announced by the broadcast mechanism in frame  $N$ .

The process M0 shall also provide the value of the PP RSSI threshold to be used by the process M1. This value is also part of the broadcast mechanism.

The exact design of the algorithms for process M0 is left to the implementers. The application profile (such as TS 102 939-1 [i.10]) may add further requirements and provide implementation guidelines.

The following general guidelines are provided for process M0:

- The algorithm should balance the goal of pre-selecting the less interfered channels with the need of offering multiple options for the process M1 (see clause 11.12.5), in order to reduce the probability of collision.
- The RFP should announce a sufficient number of channel alternatives and should not restrict unnecessarily the number of channels. Any restriction increases the probability of collisions and increases the delay that the algorithm M2 (see clause 11.12.7) has to add to handle potential collision cases.

In order to evaluate the RSSI of a candidate channel, the RFP should measure it in at least one frame and in at least one transmission direction. Evaluation criteria may be based on average of multiple RSSI measurements or may take the worst value in the worst frame or direction. It is also allowed to measure the RSSI, considering the slot split in segments and taken the worst measured value.

The exact design of the algorithms for measuring the RSSI value of any channel/slot is also left to the implementers. The application profile may introduce further requirements regarding RSSI measurements.

### 11.12.4 Broadcast mechanism

Prior to the generation of the dummy bearer in frame  $N$ , the RFP shall compute, using process M0, a list of candidate channels for setup at frame  $N+m$ , where  $m$  is a system parameter well known by both peers.

NOTE 1: In DECT ULE phase 1 (TS 102 939-1 [i.10]) the value of  $m$  is  $m = 2$ .

The list of candidate channels for setup at frame  $N+m$  shall be broadcasted in the dummy bearer of frame  $N$ , using the channel  $M_U$ , that is broadcasted in subfield B2 of the dummy (see clauses 5.3.4.7 and 7.3.5.3.2 in the present document).

The format of the list of candidate channels is a mask of 12 bits indicating if the channel corresponding to each slot and the carrier at which the base will be listening to at frame  $N+m$  is pre-selected by the RFP as a candidate channel or not. This is broadcasted in the field info 2 of the channel  $M_U$ .

In addition to the list of channels, the RFP broadcasts the PP RSSI threshold level. This is the RSSI threshold level that the PP shall use in the verification of RSSI performed by algorithm M1, This value is broadcasted in the field "info 1" of the same channel  $M_U$  in subfield 2 of the dummy bearer. See clauses 7.3.5.3.2 and 9.5.1.3 in the present document.

NOTE 2: The PP RSSI threshold level is assumed to be a function of the RFP threshold level used by process M0. The election of the PP threshold as function of the RFP threshold level is also part of algorithm M0.

### 11.12.5 Process M1 (PP side channel selection process)

The process M1 is the channel selection process that the PP shall execute before any expedited bearer setup, unless specifically mandated that process M2 shall be used.

The internal diagram of process M1 is shown in figure 11.3.

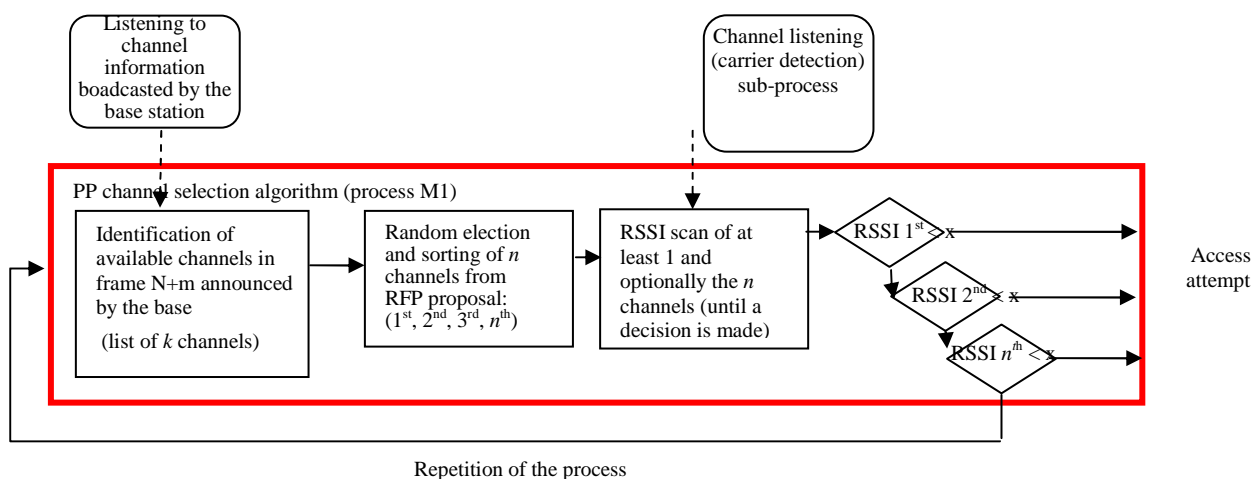

**Figure 11.3: Internal diagram of Channel Selection Process M1 (PP side channel selection process)**

The process M1 consists on the execution by the PP of the following steps:

- 1) The PP shall listen to channel selection information (channel  $U_M$ ) on ULE dummy bearer at frame  $N$ . In such information there will be a list of slots candidates for setup at frame  $N+m$ , as well as a threshold validation value. Be  $k$  the number of candidate available channels announced by the RFP.
- 2) The PP shall randomly select, from the list of  $k$  channels broadcasted by the base, at least a primary target channel, and in general, shall select a list of  $n$  channels where  $1 \leq n \leq k$  (unless  $k = 0$ , in that case no channel may be selected).
- 3) If  $n > 1$ , the PP shall randomly order the list of  $n$  channels, creating a sorted list (where the first channel according to the random sorting will be the primary target, and the last one the  $n^{\text{th}}$  target)
- 4) The PP shall measure the RSSI of the channels of the list of  $n$  channels in at least one upstream and one downstream simplex bearer. This process may be aborted when a channel selection decision is made.
- 5) The PP shall compare the RSSI of each channel with the threshold RSSI value broadcasted in the dummy together with the channel information. A channel is considered valid if both simplex bearers have passed the threshold criteria.

- 6) The PP shall select the channel as follows:
- a) If the first channel in the order of the sorted list has passed the criteria THEN this is the selected channel ELSE
  - b) If the second channel of the sorted list has passed the criteria THEN this is the selected channel ELSE
  - c) ...
  - n) If the  $n^{\text{th}}$  channel of the sorted list has passed the criteria THEN this is the selected channel ELSE
  - n+1) If no channel of the sorted list has passed the criteria THEN the process M1 shall be re-executed using a new channel selection info on a new dummy bearer.
- 7) The PP shall perform a setup attempt on the selected channel on frame N+m.

### 11.12.6 Setup attempt and evaluation of responses

Once a channel is selected by algorithm M1, the PP shall perform an access attempt (expedited access request or expedited access request ready for release) on frame N+m. The response to such access request should be evaluated. The PP shall react as follows:

- If the response is a success (valid confirmation command and correct Q1/Q2) the selection process ends.
- If the response is not successfully and cannot be discarded that it is the result of an access collision, the PP shall execute the algorithm M2.

NOTE 1: Most of error responses are in this case. F.i. no reception of the response / bad CRC.

- If the response is not successfully and it can be discarded that it is the result of an access collision, the PP may repeat algorithm M1 instead of executing M2.

NOTE 2: Only a few cases of error responses qualify for this case. It is foreseen that many implementations will not make the distinction collision candidate/collision discarded and will go to process M2 in all cases.

### 11.12.7 Process M2 (collision handling/collision avoidance process)

The process M2 will be in charge of handling potential or real collision cases and shall be invoked after a setup failure as described in clause 11.12.6.

The internal diagram of process M2 is shown in figure 11.4.

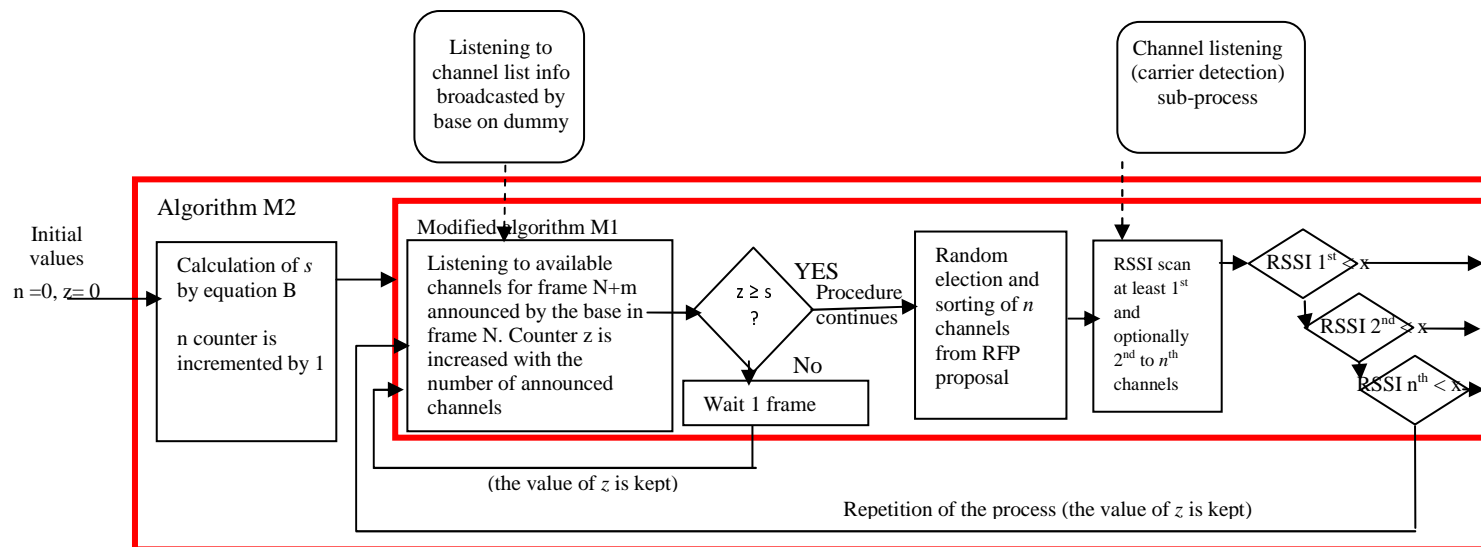

**Figure 11.4: Internal diagram of Channel Selection Process M2 (PP side collision avoidance process)**

NOTE: The modified algorithm M1 shown in figure 11,4 is similar to algorithm M1 with the addition of the counter  $z$ , the comparison  $z \geq s$  (after checking the channel selection information broadcasted by the RFP) and the one frame delay loop when  $z < s$ .



### 11.12.7.1 Equations

The following equations are used in the algorithm:

$$j = b * c^n, n = 0 \dots n_{\max} \quad (\text{Equation A})$$

$$s = a + \text{RAND}(1, j) \quad (\text{Equation B})$$

RAND(1, j) is an integer randomly chosen between (and including) 1 and j.

Parameters a, c and  $n_{\max}$  are given in annex A.2.1. Parameter b shall be given by the application profile, which may define it as a constant, or may define it as a dynamic parameter, providing the rules for its setting.

n is a natural series starting at 0 in the first execution of the algorithm and increased in each additional execution until a limit  $n_{\max}$ .

NOTE: n, the exponent in the backoff equation, should not be confused with *n* (n italic), the number of channels selected by algorithm M1.

### 11.12.7.2 Algorithm

The process M2 consists on the execution by the PP of the following steps:

- 1) Before the first execution of the algorithm, variables n and z are set to 0. In case of subsequent execution of the algorithm (in the same channel selection process) the variable z shall be reset, but variable n is increased by 1 until reaching a maximum value  $n_{\max}$ .
- 2) The PP shall calculate equations A and B and shall obtain a value of j.
- 3) After that, the n variable is increased by 1 for a possible further execution of the algorithm.
- 4) The PP shall listen to channel selection information (channel  $U_M$ ) broadcasted on ULE dummy bearer at frame N. In such information there will be a list of slots candidates for setup at frame N+ m, as well as a threshold validation value. Be k the number of candidate available channels announced by the RFP.
- 5) The PP shall add k to the counter z
- 6) If the value of z is now equal or larger than s, then the algorithm M1 shall be executed using the channel selection information that has been broadcasted in the frame N (or in the frame when  $z \geq s$ ). This may lead to a setup attempt in frame N+m.
- 7) If this is not the case, the PP shall wait one frame and go to step 4) listening to the next channel selection information broadcasted in the next frame and repeating the process until  $z \geq s$ .

Once the algorithm M1 is executed, all provisions in clause 11.12.5 and 11.12.6 apply. If no channel selection may be validated, M1 shall be executed again (this is shown in the figure as repeating step 4) of M2 keeping the value of z, since  $z \geq s$  will directly trigger M1).

If M1 was able to validate a channel selection, an access attempt was made and it failed, then the whole algorithm M2 should be repeated with an increased value of n, variable z shall be reset to 0, and a new calculation of equation B (new value of s). This is shown as the repetition loop in figure 11.2.

## 12 Medium access layer test message procedure

### 12.1 Introduction

For the purpose of testing, DECT equipment capable of transmitting shall recognize the set of test messages sent by the testing system as defined in the present document. The ability to recognize and implement these messages is contained in the Implementation Under Test (IUT). The response of the IUT to these messages is dependent on the equipment type.

DECT equipment not capable of transmitting shall not be required to recognize these messages.

NOTE: Implementation Under Test (IUT is equivalent to Equipment Under Test (EUT)).

Clause 7.2.5.4 defines the MAC layer test messages.

DECT equipment that implements only connectionless services shall not be required to implement the test messages. However, the applicant shall declare to the test laboratory how the functions of force transmit, loopback, defeat antenna diversity and clear test modes shall be initiated.

## 12.2 General

The ability to recognize and implement the test messages is resident in the medium access control layer of the IUT. Execution of these messages is inhibited unless the IUT, in addition to the normal mode operation, is also in the test standby mode. The test standby mode is invoked by some means of manual switching in the IUT (e.g. dip-switch, jumper, or key-pad code as designated by the manufacturer) to prevent accidental execution of these messages in a normal DECT environment.

Receipt of a test message causes the IUT to enter the appropriate test mode(s). The IUT shall stay in the test mode(s) indefinitely or until a "clear test modes" message is received. Receipt of this message shall clear all previously enabled test modes and return the IUT to the test standby mode (see figure 12.1).

State mode diagram for IUTs during testing

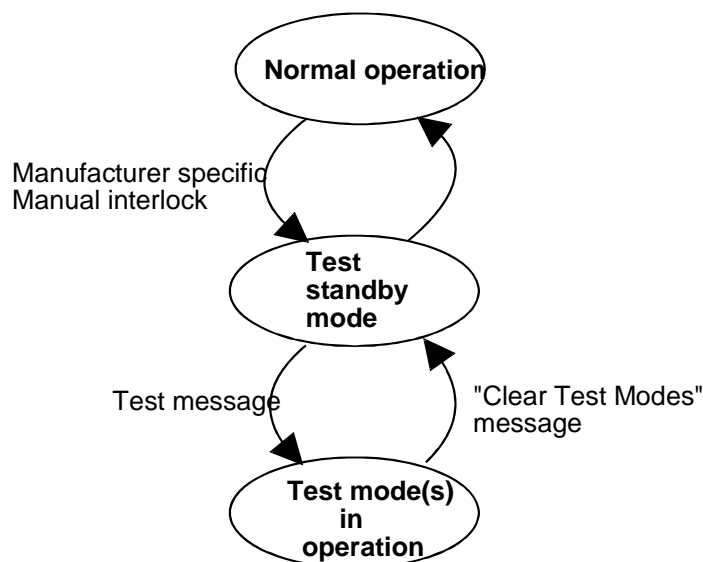

Figure 12.1: State mode diagram for IUTs during testing

After switching to the test standby mode and before the receipt of the test messages the IUT shall have no active bearers other than the dummy bearer if the IUT is an FP. When entering the test standby mode, the modulation of the bearers shall be modulation scheme 1a or 1b, refer to EN 300 175-2 [2]. Test message CHANGE\_MODULATION\_SCHEME (see clause 12.9) can be used to switch the IUT to another modulation scheme.

The IUT shall be able to be switched out of the test standby mode by the same means of manual switching as described above or by powering down the IUT. The tester should not transmit any test messages before the IUT has entered the test standby mode.

No more than one test message per multiframe shall be sent to the IUT. If, however, the manufacturer declares to the testing authority that the IUT is able to execute test messages at a higher rate, then the test messages shall be allowed to be sent at this higher rate.

Test messages are arranged into two groups. The first group comprises those messages which cause the IUT to enter a static mode of operation. The second group is dynamic. The IUT does not enter a permanent test mode after execution of the test message, i.e. the dynamic test message invokes a temporary test mode. These two groups are listed below:

**Static Modes:**

- a) FORCE\_TRANSMIT;
- b) LOOPBACK\_DATA;
- c) DEFEAT\_ANTENNA\_DIVERSITY;
- d) CHANGE\_MODULATION\_SCHEME.

**Dynamic Modes:**

- a) CLEAR\_TEST\_MODES.

All of the static test modes shall be able to be in operation at the same time.

The ESCAPE test message is neither static or dynamic; it serves to notify the IUT of the presence of a proprietary test message in the subsequent data bits.

For a detailed description of the test procedures utilizing the test messages, refer to EN 300 176-1 [10].

### 12.2.1 Portable part testing

Once in the test standby mode, the IUT shall receive in at least all frames in the first half of a multiframe and all slots declared as being supported. The EUT shall execute the test message within 16 frames of the reception of the test message.

The PP shall be able to receive and process the test messages described in clause 7.2.5.4. The PP shall be able to receive  $M_T$  tails sent on a dummy bearer in any frame allowed by the T-MUX algorithm if no bearers currently exist.

The test message shall be sent by the LT in an  $M_T$  tail using a dummy bearer if no bearers currently exist otherwise they shall be sent on an existing bearer.

### 12.2.2 Fixed part testing

The FP shall be able to receive and process the test messages described in clause 7.2.5.4 on a bearer that has been initiated by the LT.

Entry into the test standby mode is from the Active\_Idle or C/L state. The EUT shall execute the test message within 16 frames of the reception of the test message.

If there is no interference, a dummy bearer shall not change physical channels in test mode.

### 12.2.3 Applicability of test messages

For the purposes of testing, DECT equipment is divided into two equipment category types: CI-BASE equipment and CI-PROFILE equipment (see clauses 8 and 9 of EN 300 175-1 [1]). CI-BASE equipment are those implementations which do not adhere to an ETSI approved operating profile. CI-PROFILE equipment are those implementations which comply with an ETSI approved operating profile (e.g. General Access Profile (GAP)). Table 12.1 details the test messages that are required to be supported by the IUT for each equipment category type.

Table 12.1: DECT equipment categories and test messages

| Test message                                                                                                                      | CI-BASE                    | CI-PROFILE                 | CI-PROFILE-PLUS            |
|-----------------------------------------------------------------------------------------------------------------------------------|----------------------------|----------------------------|----------------------------|
| FORCE_TRANSMIT                                                                                                                    | Understand                 | Understand                 | Understand                 |
| LOOPBACK_DATA                                                                                                                     | Understand<br>(see note 4) | Understand<br>(see note 4) | Understand<br>(see note 4) |
| DEFEAT_ANTENNA_DIVERSITY                                                                                                          | Understand<br>(see note 2) | Understand<br>(see note 2) | Understand<br>(see note 2) |
| NETWORK_TEST                                                                                                                      | Ignore                     | Ignore                     | Ignore                     |
| ESCAPE                                                                                                                            | Ignore                     | Ignore                     | Ignore                     |
| CHANGE_MODULATION_SCHEME                                                                                                          | Understand<br>(see note 5) | Understand<br>(see note 5) | Understand<br>(see note 5) |
| CLEAR_TEST_MODES                                                                                                                  | Understand                 | Understand                 | Understand                 |
| NOTE 1: All DECT equipment, upon receipt of a test message, shall not malfunction regardless of the applicability of the message. |                            |                            |                            |
| NOTE 2: If equipment is declared as having antenna diversity or possessing more than one switchable antenna.                      |                            |                            |                            |
| NOTE 3: Equipment that is capable of operating in more than one of the above modes shall be tested in each mode separately.       |                            |                            |                            |
| NOTE 4: For fixed parts, loopback is described in clause 12.4.2.                                                                  |                            |                            |                            |
| NOTE 5: If equipment is declared as capable of higher level modulation.                                                           |                            |                            |                            |

## 12.3 FORCE\_TRANSMIT

### 12.3.1 Portable part

On receipt of this message, all DECT equipment capable of transmitting shall setup a bearer on the slot number, start position, and frequency specified in this message and shall listen for other messages received on this established bearer and act upon them as appropriate.

NOTE 1: This test message is sent from the LT to the IUT prior to all other test messages. This enables the other test messages to be sent on this established bearer.

NOTE 2: Where the IUTs transmitted data requires control by the LT, this message is followed by the LOOPBACK\_DATA test message.

The IUT remains in this mode until the CLEAR\_TEST\_MODES message is received. Receipt of other test messages shall not terminate this mode.

Combinations of slot pairs that are declared by the manufacturer as not being supported in the IUT for this test shall not be selected by the testing system.

If there exists a bearer at the time the IUT receives the FORCE\_TRANSMIT message, the IUT shall first examine the status of the "keep previous" bit to determine whether to release the current bearer. If the "keep previous" bit is set to "1", the IUT shall not release the old bearer. The IUT shall execute the appropriate setup procedure at the new slot and frequency indicated in the FORCE\_TRANSMIT message. If the "keep previous" bit is set to "0", the IUT shall first release any existing bearers before performing the call setup.

The maximum number of bearers active at any time shall not exceed the declared limit of the IUT.

NOTE 3: A manufacturer could include a multi-bearer force transmit test message as part of a proprietary test message set.

If the "handover disable" bit is set to "1" then bearer and connection handover shall be disabled (see clause 7.2.5.4.2).

### 12.3.2 Fixed part

The IUT shall allow bearer setup using any PMID while in the test standby mode. In addition, the IUT shall proceed with the bearer setup request on the slot pair on which the bearer setup request was received.

NOTE 1: The LT will initiate bearers with the IUT using the normal bearer setup procedures described in clause 10.2, and in this way controls the transmissions of the IUT.

NOTE 2: The FORCE\_TRANSMIT test message is not used when the IUT is a FP.

The IUT shall listen for other messages received on this established bearer.

The IUT remains in this mode until the CLEAR\_TEST\_MODES message is received. Receipt of other test messages shall not terminate this mode.

DECT equipment utilizing only the connectionless services shall not limit the number of successive transmissions.

## 12.4 LOOPBACK\_DATA

Loopback is that process by which data received in one slot is used to compose the data to be transmitted in the next half-frame. The sequence of the bits and their values as transmitted by the IUT is identical with the sequence of the bits and their values as received by the IUT.

For DECT equipment capable of setting up a bearer, the IUT shall have a bearer existing before this message can be executed by the IUT. If no bearer exists when the test message is transmitted by the tester, the IUT shall ignore this message.

DECT equipment utilizing only A-field transmissions shall loopback bits  $a_{16}$  to  $a_{47}$  of the A-field. The IUT shall not limit the number of successive transmissions.

DECT equipment capable of B-field transmission shall loopback bits  $b_0$  to  $b_{79}$  for half-slot ( $j=80$ ) implementations or bits  $b_0$  to  $b_{319}$  for full-slot implementations. Equipment supporting both half-slot ( $j=80$ ) and full-slot operation shall loopback bits  $b_0$  to  $b_{319}$ . Equipment supporting long-slot ( $j=640/672$ ) operation shall loopback bits  $b_0$  to  $b_{639/671}$ . The A-field loopback shall not be used.

DECT equipment capable of transmitting double-slots shall loopback bits  $b_0$  to  $b_{799}$ . Equipment supporting half-slots and/or full-slots in addition to the double-slot shall loopback bits  $b_0$  to  $b_{799}$ . The A-field loopback shall not be used.

### 12.4.1 Portable part

The point at which loopback occurs in the MAC of the IUT can be above or below the scrambling functions of the IUT.

If a FORCE\_BEARER\_HANDOVER message is received after receipt of the LOOPBACK\_DATA message, the IUT shall continue to operate in the loopback mode after execution of the bearer handover procedure. The IUT may transmit the loopback data on both bearers during execution of its bearer handover procedure. The IUT shall continue to operate in the loopback mode until receipt of the CLEAR\_TEST\_MODES or power down of the unit.

### 12.4.2 Fixed Part

#### 12.4.2.1 IUTs implementing the DECT scrambler

The point of loopback in the MAC of the IUT may occur above and below any scrambling functions of the IUT.

#### 12.4.2.2 IUTs implementing a proprietary scrambler

The point of loopback in the MAC of the IUT shall occur below any scrambling functions of the IUT.

NOTE: "Below" means without passing through the scrambling functions of the IUT.

## 12.5 DEFEAT\_ANTENNA\_DIVERSITY

All equipment equipped with antenna diversity shall respond to this message. The antenna selected by this message shall be used for both receive and transmit. The IUT stays on the selected antenna until a new antenna is selected or the "clear test modes" message is received.

## 12.6 NETWORK\_TEST

This message is used to invoke testing procedures resident in the network layer. The 32 bit SDU is passed through the ME SAP to the LLME. No further action is required. All implementations shall recognize the network test message, however, IUTs not implementing this method to invoke testing procedures shall ignore the network test message.

## 12.7 ESCAPE

Proprietary test messages resident in an IUT shall be declared by the manufacturer to the testing authority before testing may begin. Any transmission of a proprietary test message shall be preceded by the ESCAPE message in the same transmission. Proprietary test message(s) shall occupy bit positions  $a_{16}$  to  $a_{47}$  of the A-field. All implementations shall recognize the ESCAPE test message, however, EUTs not implementing proprietary test message(s) shall ignore the ESCAPE message.

## 12.8 CLEAR\_TEST\_MODES

The CLEAR\_TEST\_MODES message is used as a "reset" function. Its purpose is to force the IUT back to the test standby mode. Receipt of this message shall clear all previously enabled static test modes (including static proprietary modes) within 16 frames and return the IUT to the test standby mode.

## 12.9 CHANGE\_MODULATION\_SCHEME

On receipt of the CHANGE\_MODULATION\_SCHEME message the IUT shall switch to the requested modulation scheme if this requested modulation scheme is supported by the IUT. The message can be received by the IUT in test-standby-mode after setup of a bearer using 2-level modulation in the A-Field.

---

## Annex A (normative): MAC layer timers and constants

### A.1 Timers and Time Windows

|                      |                                                                                  |
|----------------------|----------------------------------------------------------------------------------|
| T200 = 3 s:          | connection setup timer.                                                          |
| T201 = 5 s:          | max. time-out for bearer failure.                                                |
| T202 = 3 s:          | handover timer/window.                                                           |
| T203 = 16 frames:    | max. time to maintain 2 bearers during handover.                                 |
| T204 = 6 multiframe: | time-out for sending page messages.                                              |
| T205 = 10 s:         | max. time between $N_T$ tails in frame 0 of a multiframe.                        |
| T206 = 10 frames:    | max. respond time for extended system information.                               |
| T207 = 5 s:          | max. time between reception of a correct A-field in idle mode.                   |
| T208 = 20 s:         | max. time between reception of an $N_T$ message in idle mode.                    |
| T209 = 30 s:         | max. time between update of channel list.                                        |
| T210 = 2 s:          | time window for max. $N_{202}$ channel selections.                               |
| T211 = 3 s:          | connection modification timer.                                                   |
| T212 = 20 frames:    | time to acknowledge a double simplex bearer setup.                               |
| T213 = 20 frames:    | time to acknowledge a double simplex bearer release.                             |
| T214 = 20 frames:    | C/L uplink service: maximum time to search for a dummy or connectionless bearer. |
| T215 = 6 multiframe: | interval for max. $N_{203}$ C/L uplink transmissions.                            |
| T216 = 8 multiframe: | max. time for a PP to resynchronize in idle locked state.                        |
| T217 = 300 ms:       | MAC C-plane switching timer.                                                     |
| T218 = 3 s:          | 32 kbit/s to 64 kbit/s switching timer.                                          |

---

### A.2 Constants

|                  |                                                                            |
|------------------|----------------------------------------------------------------------------|
| $N_{200} = 10$ : | max. number of MAC setup reattempts during connection setup.               |
| $N_{201} = 15$ : | max. number of handover reattempts in T202 s.                              |
| $N_{202} = 10$ : | max. number of channel selections in T210 s.                               |
| $N_{203} = 6$ :  | max number of C/L uplink transmissions in any interval of T215 multiframe. |
| $N_{204} = 5$ :  | max number of MAC C-plane switching attempts.                              |
| $N_{205} = 6$ :  | max number of MAC U-plane switching attempts.                              |
| $N_{206} = 12$ : | max. number of frequency replacement requests.                             |
| $N_{207} = 4$ :  | max. number of frequency replacement confirms or grants.                   |

|             |                                                                                                                   |
|-------------|-------------------------------------------------------------------------------------------------------------------|
| N208 = 64:  | minimum start value of multiframe countdown for "no-emission" mode (value 64 corresponds to a duration = 10,24s). |
| N209 = 16:  | minimum number of multiframe with "countdown stopped" transmissions for "no-emission" mode.                       |
| N210 = 256: | number of frames with DummyPointer transmissions for "no-emission" mode.                                          |
| N211 = 16:  | number of frames with DummyRequest transmissions for "no-emission" mode.                                          |

## A.2.1 Constants for the ULE channel selection algorithms

|                  |                                                                    |
|------------------|--------------------------------------------------------------------|
| $a = 0$ :        | fixed, not random component, of the backoff equation B             |
| $c = 2$ :        | base of the exponential term in the backoff equation A             |
| $n_{\max} = 5$ : | maximum exponent in the exponential term in the backoff equation A |

Parameter  $b$  shall be given by the application profile, which may define it as a constant, or as a dynamic parameter, providing the rules for its setting.



## Annex B (informative): Construction of the CRC polynomial and error detecting performance

The factorization of the polynomial  $g(x)$  results in:

- $g(x) = M_7(13)(x) \times M_7(29)(x) \times (x + 1)^2$ ;
- $202\ 611 = 203 \times 253 \times (3)^2$  (octal).

$M_7^{(i)}(x)$  denotes the minimal polynomial of  $\alpha^i$  where  $\alpha$  is the primitive element of  $G_{\mathbb{F}}(2^7)$  used in Appendix C of Peterson and Weldon "Error correcting codes" [i.3].

The product of  $M_7^{(13)}(x) \times M_7^{(29)}(x)$  results in a generator polynomial for a primitive binary (127, 113) BCH code with minimum Hamming distance of 5. Multiplying this polynomial with  $(x + 1)^2$  gives the generator polynomial  $g(x)$ . For different data block lengths  $n$  the minimum Hamming distance  $d_{\min}$  for the  $(m, n)$  block code generated with  $g(x)$  is given in table B.1.

**Table B.1**

| $d_{\min}$ | $m = n + 16$ |
|------------|--------------|
| 6          | 17 to 128    |
| 4          | 129 to 254   |
| 2          | $\geq 255$   |

The polynomial  $g(x)$  has the minimum number of non zero coefficients for codes with  $d_{\min} = 6$ .

For  $17 \leq m \leq 128$  the resulting  $(m, n)$  block code provides the following error detection properties:

- detect all odd number of errors;
- any error pattern with less than 6 errors; and
- any error-burst up to length 16.

Because a BCH code is included, up to double error correcting may be applied.

## Annex C (informative): MAC relationship to other layers

A complete DECT fixed radio termination may contain several independent cells, where each cell contains one independent physical layer instance (independent radio transceivers).

The MAC layer provides an intermediate level of grouping between these distributed physical layers and the single (central) instance of the higher layers. This intermediate grouping is termed a (MAC) cluster, where one cluster represents a single MAC layer instance. A complete FT may thereby contain two levels of hierarchy:

- one FT may contain multiple independent MAC clusters (MAC layer instances);
- each cluster may control multiple independent PHL cells (physical layer instances).

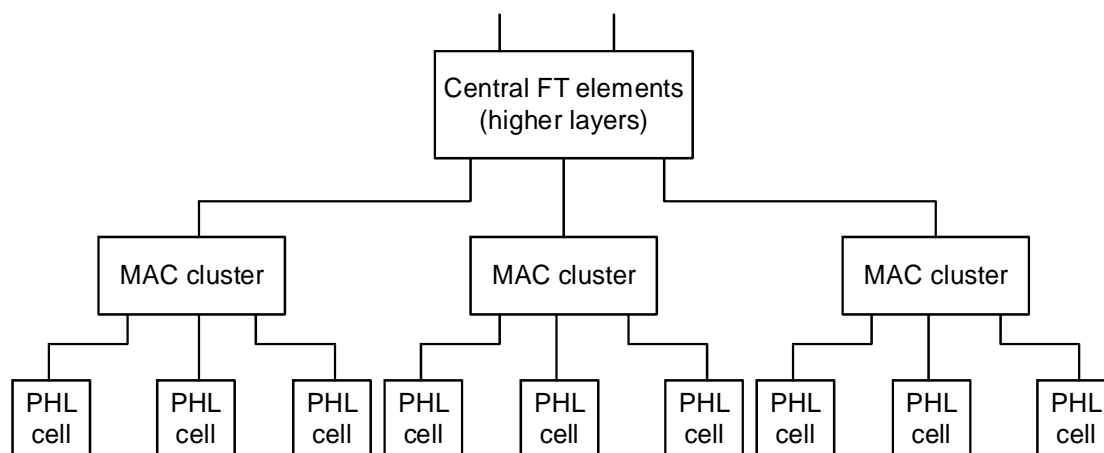

NOTE: The divisions in this picture do not correspond to physical boundaries.

**Figure C.1: FT with multiple MAC clusters**

The independent lower instances of MAC and PHL are all accessed via independent sets of service access points. The MAC functional groupings correspond to these independent SAPs.

The single instance of MAC cluster control functions relate to the single set of upper SAPs.

The multiple instances of MAC cell site functions relate to the multiple instances of lower SAPs. (There is one CSF for each PHL cell belonging to the cluster).

---

## Annex D (informative): Synchronization

The MAC layer, in combination with the physical layer provides synchronization between fixed radio termination and portable radio terminations. In all cases, the FT is the timing master, and a PT is always required to synchronize to an FT before it can obtain service.

Three types of synchronization are defined:

- slot synchronization; refer to EN 300 175-2 [2];
- frame synchronization; refer to EN 300 175-2 [2];
- multiframe synchronization; refer to clause 4.2.3.

Synchronization of a PT is achieved and maintained by the reception of physical packets by the physical layer for any active slots. This provides the first level of timing. A small number of messages are then used in the Q logical channel to define frame synchronization and multiframe synchronization relative to this slot timing. This process is defined in clause 6.2.2.1.

The FT transmissions are required to be frame and multi-frame synchronized at all RFPs in any one cluster. It is required that this synchronization is maintained across a complete fixed radio termination.

At the PT, successful synchronization is required for the PT to "lock" to the transmissions of an FT. A PT can exist in one of three synchronization states at the MAC layer:

- 1) **Unlocked:** the PT is not synchronized to any RFP;
- 2) **Lock\_pending:** the PT is receiving RFP transmissions, but has not yet obtained frame and/or multiframe synchronization;
- 3) **Locked:** the PT has achieved frame and multi-frame lock to an RFP.

## Annex E (normative): Scrambling patterns

Table E.1 lists the first 16 bits and the last 2 bits (for both full and half slots) of the scrambling bit sequence that shall be used each frame.

The sequence repeats every 8 frames, so the sequence is the same for frames 0 and 8, and for frames 1 and 9, etc.

**Table E.1**

| Bit<br>number    | FRAME NUMBERS |        |         |         |         |         |         |         |
|------------------|---------------|--------|---------|---------|---------|---------|---------|---------|
|                  | 0<br>8        | 1<br>9 | 2<br>10 | 3<br>11 | 4<br>12 | 5<br>13 | 6<br>14 | 7<br>15 |
| b <sub>0</sub>   | 0             | 0      | 0       | 0       | 0       | 0       | 0       | 0       |
| b <sub>1</sub>   | 0             | 0      | 0       | 0       | 0       | 0       | 0       | 1       |
| b <sub>2</sub>   | 1             | 1      | 1       | 1       | 0       | 0       | 0       | 1       |
| b <sub>3</sub>   | 1             | 1      | 0       | 0       | 1       | 1       | 0       | 1       |
| b <sub>4</sub>   | 1             | 0      | 1       | 0       | 1       | 0       | 1       | 1       |
| b <sub>5</sub>   | 0             | 0      | 1       | 1       | 0       | 0       | 1       | 0       |
| b <sub>6</sub>   | 1             | 1      | 0       | 1       | 0       | 1       | 0       | 0       |
| b <sub>7</sub>   | 1             | 0      | 1       | 1       | 1       | 1       | 0       | 1       |
| b <sub>8</sub>   | 1             | 1      | 1       | 0       | 0       | 1       | 1       | 1       |
| b <sub>9</sub>   | 1             | 1      | 1       | 1       | 1       | 0       | 0       | 0       |
| b <sub>10</sub>  | 0             | 0      | 1       | 1       | 1       | 1       | 1       | 1       |
| b <sub>11</sub>  | 0             | 1      | 0       | 1       | 0       | 1       | 1       | 0       |
| b <sub>12</sub>  | 1             | 1      | 1       | 1       | 1       | 1       | 0       | 0       |
| b <sub>13</sub>  | 1             | 1      | 0       | 0       | 1       | 1       | 1       | 1       |
| b <sub>14</sub>  | 0             | 1      | 1       | 0       | 1       | 0       | 1       | 0       |
| b <sub>15</sub>  | 1             | 0      | 0       | 1       | 1       | 0       | 1       | 0       |
| etc.             |               |        |         |         |         |         |         |         |
| b <sub>78</sub>  | 0             | 1      | 0       | 1       | 0       | 1       | 1       | 0       |
| b <sub>79</sub>  | 0             | 0      | 0       | 0       | 1       | 1       | 0       | 0       |
| etc.             |               |        |         |         |         |         |         |         |
| b <sub>317</sub> | 1             | 0      | 1       | 1       | 1       | 1       | 0       | 1       |
| b <sub>318</sub> | 1             | 1      | 1       | 0       | 0       | 1       | 1       | 1       |
| b <sub>319</sub> | 1             | 1      | 1       | 1       | 1       | 0       | 0       | 0       |

## Annex F (informative): Seamless handover operation

### F.1 I channel data flow for $I_N$ \_minimum\_delay service

When two bearers are maintained during bearer handover in an  $I$ \_minimum\_delay\_service the data transmitted in one frame is not the same for the two bearers using physical channels in different time slots. For transmission, the voice service description in the DLC (see EN 300 175-4 [4]) (LU1) implies that the response on a MAC\_CO\_DTR-ind primitive is a MAC\_CO\_DATA-req primitive containing the **latest** octets. Therefore the data depends on the time instant when the MAC\_CO\_DTR-ind primitive was sent. To achieve minimum delay the occurrence of this primitive should depend on the slot number used by a particular physical channel. This implies that during a bearer handover two MAC\_CO\_DTR-ind primitives are sent in one frame and two MAC\_CO\_DATA-req primitives are received by the MBC containing different data for the old and the new bearer. For a handover in which no  $I_N$  bits are to be lost or added due to the handover, synchronization between MAC and DLC is necessary. It is recommended to synchronize the MAC and DLC such that the relative offset in data octets for delivering  $I_N$ -segments to bearers in different slot positions is given in tables F.1, F.2 and F.3.

**Table F.1: Double slot operation**

| Slots  | Octet | Slots  | Octet  | Slots   | Octet  |
|--------|-------|--------|--------|---------|--------|
| (0,12) | x + 0 | (4,16) | x + 16 | (8,20)  | x + 32 |
| (2,14) | x + 8 | (6,18) | x + 24 | (10,22) | x + 40 |

NOTE: The slot numbers correspond to the slots where transmission on a double slot bearer starts.

**Table F.2: Full slot operation**

| Slots  | Octet | Slots  | Octet  | Slots   | Octet  |
|--------|-------|--------|--------|---------|--------|
| (0,12) | x + 0 | (4,16) | x + 6  | (8,20)  | x + 13 |
| (1,13) | x + 1 | (5,17) | x + 8  | (9,21)  | x + 15 |
| (2,14) | x + 3 | (6,18) | x + 10 | (10,22) | x + 16 |
| (3,15) | x + 5 | (7,19) | x + 11 | (11,23) | x + 18 |

NOTE: For half slot operation: no recommendation.

**Table F.3: Long slot (j=640) operation**

| Slots  | Octet  | Slots  | Octet  | Slots   | Octet  |
|--------|--------|--------|--------|---------|--------|
| (0,12) | x + 0  | (4,16) | x + 13 | (8,20)  | x + 26 |
| (1,13) | x + 3  | (5,17) | x + 16 | (9,21)  | x + 30 |
| (2,14) | x + 6  | (6,18) | x + 20 | (10,22) | x + 33 |
| (3,15) | x + 10 | (7,19) | x + 23 |         |        |

NOTE: The slot numbers correspond to the slots where transmission on a long slot (j=640) bearer starts.

---

## Annex G (normative): Requirements for PPs with direct PP to PP communication mode

### G.1 Description of operation in direct PP to PP communication mode

Direct PP to PP communication is a notation for a PP (or CTA) feature that provides ad hoc networking with specific temporary system ad hoc identities. A PP temporarily switches into FT mode to provide direct access to any of the other PPs of the ad hoc network. There is no requirement or need to being locked to an RFP. Since no RFP is involved in the communication link, direct PP to PP communication only uses half the spectrum compared to normal calls routed via RFPs.

Most PPs will be able to operate also in the normal non-direct communication mode. In this case the direct mode will be temporary, and all PPs in a group of PPs intended to communicate in direct communication mode have to be switched into this mode (manually or by other means), since a PP in non-direct mode can only receive paging information from the system to which it is locked.

The access rights class E and related PARK E are reserved for direct communication only, see EN 300 175-6 [6], clauses 5.5, 6.1.5 and 6.3.2. The Access Rights Identity (ARI) class E requires an entry via keypad or by other means of only 5 decimal digits to provide all identity and subscription data required to form a group of PPs for direct communication. The subscriber numbers consist of 2 decimal digits. The use of class E identities is normally of temporary nature and does not contain an ETSI distributed code.

When there is no communication all PPs are active unlocked, no (dummy) bearer transmission exists, and all PPs are regularly scanning all allocated access channels for a (dummy) bearer transmission with proper Radio Fixed Part Identity (RFPI).

When a PP wants to initiate a connection, it acts like an RFP, selects a least interfered channel within the allocated carriers and starts transmitting a simplex (dummy) bearer with the relevant page message and  $Q_T$  information. The paged PP shall enter idle locked mode, and shall respond with a bearer setup.

A PP entering RFP mode is allowed to derive over the air slot synchronization from a "non ARI E" DECT system, e.g. a large office system.

The requirements below allow for two slightly different procedures:

- Alternative 1: where the additions for the RFP mode are minimized; and
- Alternative 2: where the changes in the PP mode are minimized compared to GAP.

For interoperability the PPs have to conform to a specific interoperability profile (e.g. a PP to PP option in GAP or DPRS).

---

## G.2 Requirements

PPs or CTAs in direct communication mode shall meet the PP requirements for normal non-direct communication with the amendments defined below.

### G.2.1 Setting the PP in direct communications mode

Entering and leaving the direct communications mode shall be made by manual keypad entries or by other means. The PP shall be set in direct communications mode provided with proper identities. It is proper to use of class E identities which do not require an ETSI distributed code. The requirements for class E identities are found in EN 300 175-6 [6], clauses 5.5, 6.1.5 and 6.3.2.

When not processing a call, the PP shall be in active unlocked PP state.

### G.2.2 Specific Alternative 1 requirements

#### G.2.2.1 When the PP has not initiated a call

When the PP has not initiated a call, it shall operate as a "non-direct mode" PP starting from the active unlocked PP state, but with the following amendments:

- a) the PP shall in the active unlocked PP state scan all channels on relevant carriers at least every 10 s;
- b) the PP is only allowed to stay in idle locked state if it is being paged by an initiating PP (it shall unlock to detect page messages from other PP);
- c) if ARI class E is used, the paged PP shall make the bearer setup attempt on the channel pair where the initiating PP transmits.

#### G.2.2.2 When the PP initiates a call

By initiating a call means that the number of the wanted subscriber is entered via the keypad or by other means, and that the PP at "off-hook command" shall enter the RFP active idle state, see clause 4.3.

When the PP initiates a call, it shall operate as a "non-direct mode" RFP starting from the active idle RFP state, with the following amendments:

- a) the 25 ppm PP timer stability requirements apply. See EN 300 175-2 [2], clause 4.2.2;
- b) a PP entering RFP mode is allowed to derive over the air frame and slot synchronization from a DECT system having "non-class E" identities;
- c) the PP shall use FP or PP simplex bearer channel selection rules for the RFP active idle state. See clause 11.4;
- d) the page message shall be transmitted in every multiframe as long as in active idle state;
- e) the short page format shall be used for ARI class E;
- f) the PP shall revert from active idle RFP state to PP active unlocked state, if a duplex bearer has not been established within 20 s;
- g) the PP is not required to do receiver scanning for ARI class E in RFP active idle nor active state. See clause 11.8 and EN 300 175-6 [6], clause 5.5;
- h) if identities class E are used, the  $N_T$  message will not contain an ETSI distributed code. See EN 300 176-1 [10].

## G.2.3 Specific Alternative 2 Requirements

The PP shall meet the requirements of clause G.2.2 except for items b) and c) in clause G.2.2.1 and item g) in clause G.2.2.2.

In addition:

- a) the initiating PP is not required to do receiver scanning for ARI class E (see clause 11.8 and EN 300 175-6 [6], clause 5.5) in RFP active idle nor active state, if it transmits a blind slot information indicating that all slots except the dummy bearer timeslot are blind and if it has set bit  $a_{20}$  in the Q3 message to "1".



# Annex H (normative): Requirements for FPs with Wireless FT to FT (W-FT2FT) communication mode

## H.1 Introduction

Wireless FT to FT communication (W-FT2FT) is a notation for a FP (or HyP) feature that provides the possibility of wireless communication between two independent DECT systems served by two different FPs.

The W-FT2FT communication apart of providing direct communication between two FPs can be used implicitly to provide communication between a PP locked to an FT and another FT and all services that this second FT provides. The main difference between a WRS and a FP supporting W-FT2FT communication is that the later does not relay calls rather uses two separate independent calls.

An example of such system configuration is provided on figure H.1.

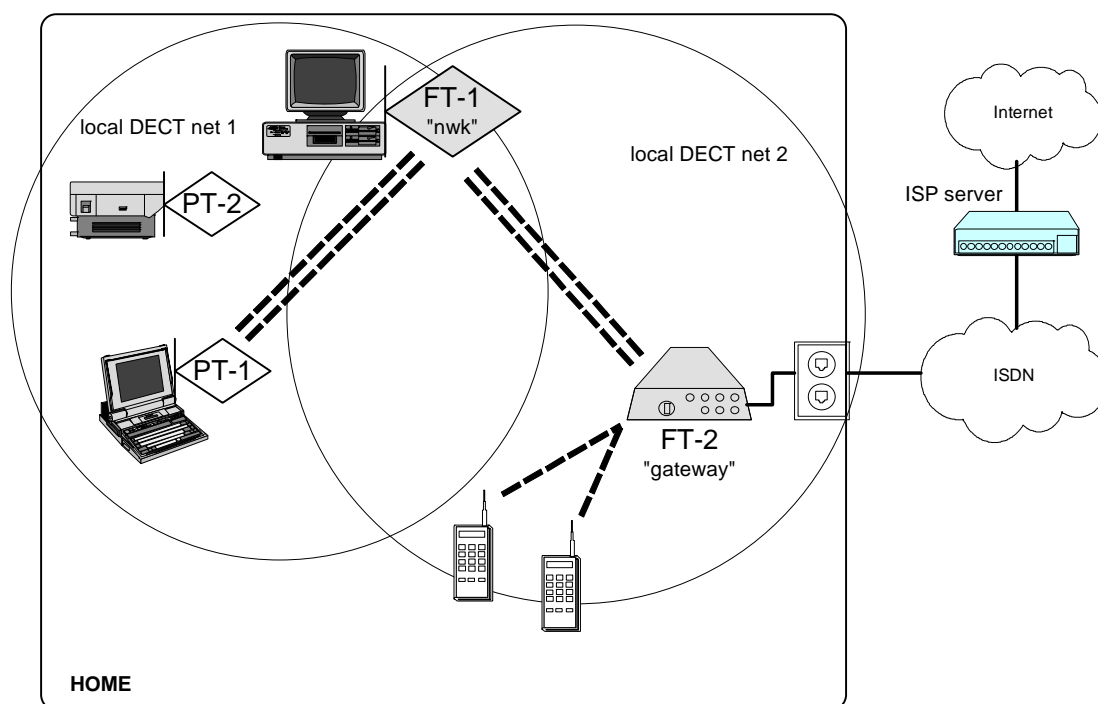

**Figure H.1: W-FT2FT communication**

Some examples of application of the W-FT2FT communications are systems scenarios where communication between two subsystems served by different FPs is needed and communication via cable is either impossible or undesirable. Local separation of DECT networks where an FP is implemented as part of another communication device (e.g. a PC as on figure H.1) and another DECT FP is used for providing access to additional services (e.g. Internet as on the figure H.1) is another example which provides opportunities for implementation cost savings allowing for usage of the resources of the communication device.

---

## H.2 Description of operation in W-FT2FT communication mode

A FP that supports W-FT2FT communications shall be capable of:

- supporting the normal FT operation as defined currently in the relevant DECT standards;
- activating a special W-FT2FT mode.

In W-FT2FT mode the FT shall be capable to:

- search for, synchronize and lock to another FT following the rules defined for a PT currently in the DECT protocol; if necessary re-synchronize with the local NWK;
- register (subscribe) to another FT as a PT;
- perform with another FT other Mobility management procedures defined for a PT currently in the DECT protocol, e.g. location registration, ciphering, FT authentication, etc.; in all these procedures the FT that supports W-FT2FT communication shall behave as a PT;
- establish a connection to another FT acting as a PT for the purpose of exchanging user data (i.e. a call);
- if connectionless services are to be supported, exchange connectionless information with another FT acting as a PT and following the rules defined for a PT currently in the DECT protocol.

The W-FT2FT mode has impact only on the FT that implements it and not to any PT that it may serve nor a FT it communicates with.

When operating in W-FT2FT mode, the FT may use 2 separate DECT protocol stacks each to handle the relevant mode (one for FT mode and one for PT mode). Alternatively, a unified protocol stack could be used where the differentiation is made on application level and necessary information is exchanged via the DECT LLME. A management entity may handle the slot allocation and utilization between the MAC and the PHY layers (not visible to the peer, hence not due to standardization).

The DECT LLME entity is responsible for "switching" an FT between different modes.

## Annex I (normative): Channel coding and Modulation

Channel coding and Modulation are applied on the data to generate the B-field data in the full slot structure (physical packet channel P32), the double slot structure (physical packet P00j with  $j=80$ ) and the half-slot structure (physical packet P08j) providing high data bit rate per channel  $R_a(K, L, M, N)$ .

Useful bits issued from the data source are encoded, punctured (leading to a specific adaptive code rate  $r$ ) and mapped within the B-Field. The overall transmission chain including multiplex functions is shown in figure I.1.

The Encoder is intended to mitigate deep fading effects that damage the B-field data transmission. Burst errors during the transmission affect both useful bits and parity bits (see clause I.1.2.2). Decoding processing leads to an improved decision on transmitted useful bits. Turbo decoding (see annex J) integrated in an iterative processing loop ensures an efficient and adaptive decoding processing fit to the propagation channel constraints and the desired bit rate target and QoS to the service transmission.

The Puncturing combined with several modulation level schemes allows a large available bit rate range (see table I.2) for each propagation scenario (see table I.1). The adaptive bit rate implementation is adjusted in regards with the concerned propagation scenario and the B-field data framing. Puncturing gives an efficient mapping of encoded bits within every symbol. It is defined in such a way that parity bits and net bits are arranged in a specific way within the symbols (see clause I.2.2).

The bit mapping is compliant with the B-field mapping (B-MAP) implementation (see clause 6.2.1.3) conducting to P00, P32, P00j and P80 physical packet channel formats (see EN 300 175-2 [2]).

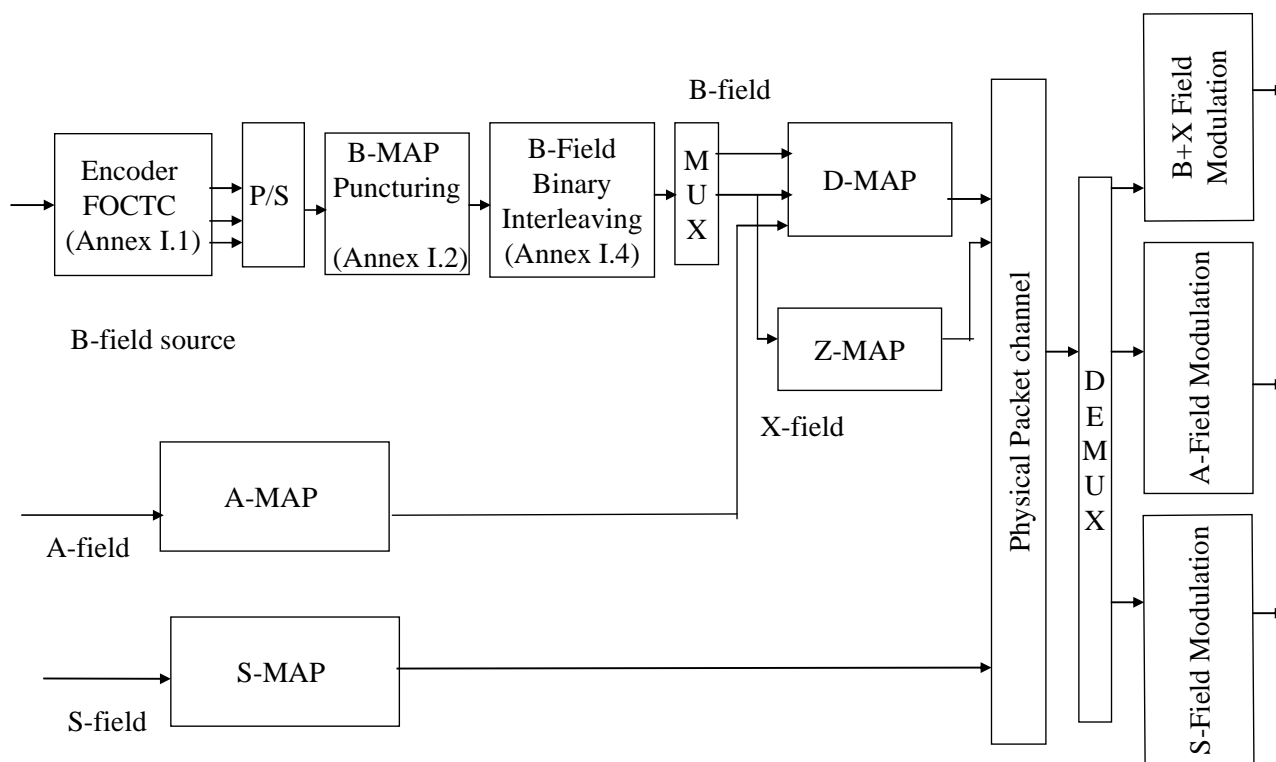

Figure I.1: B-field Channel Encoding scheme

## I.1 Channel coding

Channel coding is applied on the data to form B-field data. Turbo channel encoding combined with puncturing conducts to the B-field map defined in the clause 6.2.1.3. Various net bit rates are proposed for each propagation scenario from selected adaptive code rate set-ups (with puncturing schemes) and appropriate modulation schemes (see table 6.1).

The implemented channel coding is based on the Turbo Code Principle that provides the most outstanding performance over selective propagation channels. A parallel turbo-code structure, in compliance with a data framing, has been chosen and is called FOCTC (Frame Oriented Convolutional Turbo-code, see [i.5]).

The turbo-decoding processing benefits from an optimized inner interleaver and efficiently exploits the extrinsic information in the decoding processing (see annex J).

### I.1.1 The parallel Turbo Code Principle

The Turbo Code concept introduced by Berrou (see [i.4] and [i.5]) results in two parallel-concatenated convolutional codes where the same information sequence is fed into 2 coders in different ways. The information sequence is directly fed to the encoder 1 (COD1, figure I.2) while an interleaved version is sent to the encoder 2 (COD2, figure I.2). The resulting encoder generates a systematic code with a code rate  $r_{\text{fix}}=1/3$ . The classic parallel - concatenated Turbo Code Encoder structure is shown in figure I.2.

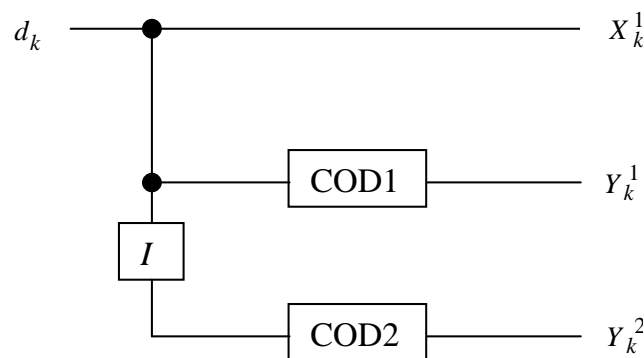

**Figure I.2: Classic parallel - concatenated Turbo Code Encoder structure**

Main benefits of this structure result in the decoding processing as described in annex J.

### I.1.2 The FOCTC implementation

#### I.1.2.1 The FOCTC concept

The FOCTC concept (see [i.5]) is an adaptation of parallel-concatenated convolutional codes to a burst mode transmission with a block size set to  $K$  which is a multiple of the constraint length  $M'$  of the basic encoder (COD1 and COD2). The principle consists in using a single Recursive Convolutional Encoder instead of two encoders and forcing the state of the encoder to zero at the end of each burst. This assumption is obtained by using a code with components which divide a polynomial  $P(D) = 1 + D^{M'}$ .

The information sequence with a  $K$  size and the interleaved version of the same sequence are alternatively sent to the Recursive Channel Encoder (COD1 is identical to COD2). The input bit  $X_k^1$  of the information sequence  $D$  composed of  $K$  bits is fed to the FOCTC structure and generates a sub-block of 3 bits  $X_k^1, Y_k^1, Y_k^2$  where  $X_k^1$  corresponds to the initial bit at the input of the encoder at the time  $k$ ,  $Y_k^1$  is the parity bit issued from the COD1 and  $Y_k^2$  is the parity bit issued from the interleaved bit  $X_k'^1$  that has been fed to the encoder COD2. The resulted encoded bits are composed of  $K$  series of 3 bits  $\{X_k^1, Y_k^1, Y_k^2\}$ .

In order to maintain the state of the encoder to zero at the end of each burst ( $D$  sequence):

- The block size  $K$  of the input sequence is a multiple of  $M'$  where  $M'$  is the constraint length of the Recursive Channel Encoder (COD1, COD2).
- The encoder has to be first initialized at state zero at the beginning of each burst.
- The inner interleaver shall follow the rule, that each interleaved bit  $d'(k)$  has to be delayed by a multiple of the constraint length  $M'$  of the encoder, meaning that:

$$K = n \cdot M'$$

$$d'(k) = d(I(k)) \quad k = \{0, \dots, K-1\}$$

(Equation I.1)

with :

$$I(k) = k + m(k) \cdot M'$$

$I(k)$  is a bijective function, thus we have:

$$0 \leq I(k) = m(k) \cdot M' + k \leq K-1 \quad \forall k \in \{0, \dots, K-1\}$$

(Equation I.2)

Where  $m(k)$  is an integer element in the  $Z$  space. The inner algorithm is detailed in the clause I.1.2.3.

### I.1.2.2 The FOCTC structure and the component code

The FOCTC coder structure is composed of two identical Recursive Convolutional Encoder (RCE) in a turbo coding structure.

Each encoder component is a 16-state encoder with a code rate set to  $r = 1/2$ . Associated generator polynomials are  $g_0 = 37_0$  and  $g_1 = 25_0$  in octal format (see figure I.3).

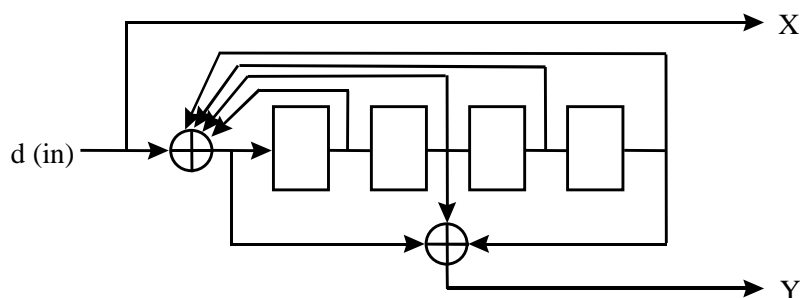

**Figure I.3: Recursive Systematic Convolutional (RSC) code**

The generator polynomials in a binary representation are expressed as follows:

$$G_0(D) = D^4 + D^3 + D^2 + D + 1$$

(Equation I.3)

$$G_1(D) = D^4 + D^2 + 1$$

(Equation I.4)

$$G0 = \{g_0^4, g_0^3, g_0^2, g_0^1, g_0^0\} = (1,1,1,1,1) \quad (\text{Equation I.5})$$

$$G1 = \{g_1^4, g_1^3, g_1^2, g_1^1, g_1^0\} = (1,0,1,0,1) \quad (\text{Equation I.6})$$

The binary input is  $d(k)$ .

The encoder has two binary outputs:

$$X(k) = d(k) \quad (\text{Equation I.7})$$

$$Y(k) = \sum_{i=0}^M g_1^i \times a(k-i) \quad (\text{Equation I.8})$$

$$a(k) = d(k) \oplus \sum_{j=1}^M g_0^j \times a(k-j) \quad (\text{Equation I.9})$$

Where  $M$  corresponds to the size of memory elements ( $M' = M + 1$  is the constraint length of the encoder).

In a FOCTC turbo coding structure, the RCE encodes two information sequences: the first one corresponds to the input sequence  $X$ , the second one is an interleaved version of this sequence denoted as  $X'$ . The sequence size is  $K$ .  $K$  shall be a multiple of the constraint length  $M'$  of the RCE encoder.

$$M' = 5 \quad (\text{Equation I.10})$$

The corresponding structure is shown in figure I.4.

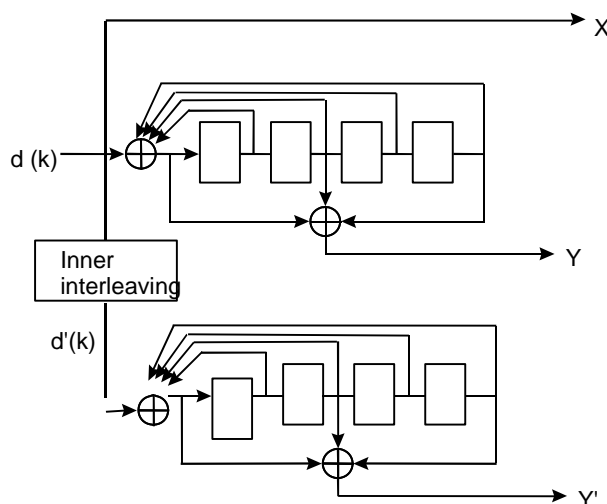

**Figure I.4: FOCTC structure**

Let assume that  $K$  is the size of the binary information sequence. The binary input is:

$$d_0, d_1, d_2, d_3 \dots d_{K-1} \quad (\text{Equation I.11})$$

The output of the FOCTC is composed of three bitstreams.

$$\begin{aligned} x_0, x_1, x_2, x_3 \dots x_{K-1}, \\ y_0, y_1, y_2, y_3 \dots y_{K-1}, \\ y'_0, y'_1, y'_2, y'_3 \dots y'_{K-1} \end{aligned} \quad (\text{Equation I.12})$$

Where  $x(k)$  is identical to  $d(k)$

$y(k)$  is given by:

$$y(k) = \sum_{i=0}^{M} g_1^i \times a(k-i) \quad (\text{Equation I.13})$$

$$a(k) = d(k) \oplus \sum_{j=1}^{M} g_0^j \times a(k-j) \quad (\text{Equation I.14})$$

and  $y'(k)$  is given by:

$$y'(k) = \sum_{i=0}^{M} g_1^i \times a(k-i) \quad (\text{Equation I.15})$$

$$a(k) = d'(k) \oplus \sum_{j=1}^{M} g_0^j \times a(k-j) \quad (\text{Equation I.16})$$

The basic FOCTC encoder works on data blocks that are multiple of  $M'$  bits. The decoding processing is based on Max log MAP algorithm (see [i.6]) and metrics are beforehand quantized upon 12 bits.

The inner interleaver has to keep up the constraints (I.1) and (I.2) meaning that each interleaved bit is delayed by a multiple of the constraint length  $M'$  of the Recursive Convolutional Encoder. Under this constraint, interleaving algorithm is implemented in a pseudo random way with a block size  $K$ , which is a multiple of  $M'$ . The block size  $K$  of each configuration is adjusted to the B-field size of the corresponding physical packet format Pxx. The equation (I.17) gives the relation between  $K$ , B-field size, the code rate  $r$  and the modulation level  $L = 2^m$ .

$$K = B - \text{field} - \text{size} \cdot r = \text{Number} - \text{of} - \text{data} - \text{symbol} - \text{per} - \text{physical} - \text{packet} \cdot P_x \cdot m \cdot r$$

$$x = \{80, 32\} \quad (\text{Equation I.17})$$

$m$ : number of bits per data – symbol

$r$ : global code rate of the B – field encoded data (table I.2)

The code rate  $r$  and the modulation level  $2^m$  ( $m$ : number of bits per B-field data symbol) applied to the initial data sequence constituted with useful bits is firstly adjusted to:

- The desired net bit rate range of the concerned Physical Packet format Pxx.
- The propagation characteristics and the corresponding propagation scenario (see table I.1).
- The desired B-field data size ( $B=K/r$ ) in compliance with the Physical Packet format.

These two ( $r$  and  $m$ ) parameters are refined to provide the most outstanding performance for each propagation scenario. Following these constraints, the interleaving rule imposing that  $K$  is a multiple of  $M'$  (constraint length of the encoder) for the FOCTC is not always fulfilled.

For the Physical Packet format P80, the interleaving rules given by the equations (I.1) and (I.2) are always fulfilled (see table I.2). For the P32 and P00j physical packet formats, the interleaving rule imposing that the block size is a multiple of  $M'$  is not fulfilled for a few configurations (see table I.2). It requires an adaptation of the size of the interleaved sequence which is explained in the clause I.1.2.4.

### I.1.2.3 The FOCTC Inner interleaving algorithm

The FOCTC structure is a self-terminating trellis scheme without additional tail bits which imposes that the block size  $K$  of the inner interleaving is a multiple of the constraint length  $M'$  of the encoder (equation I.1). This clause defines the inner interleaving algorithm that respects inner interleaving constraint (equation I.1). The clause I.1.2.4 provides an adaptation of the inner interleaving pattern when the block size is different from  $K = p \times M'$ .

The inner interleaving algorithm is based on Prime Relative interleaving algorithms which generates the interleaving pattern along a generic way.

Let assume that  $k$  is the position of the bit  $b(k)$  within the useful sequence  $D$  at the input of the inner interleaving and  $D'$  the inner interleaving pattern at the output of the interleaving. The Inner interleaving algorithm defines a new position of the bit  $b$  in the sequence that is determined by  $I(k)$  meaning that:

$$b'(k) = b(I(k)) \quad (\text{Equation I.17a})$$

where  $b'(k)$  is interleaved bit at the position  $k$  in the sequence  $D'$ .  $b'(k)$  corresponds to the initial bit  $b(I(k))$  positioned at  $I(k)$  in the initial sequence  $D$  at the input of the interleaving.

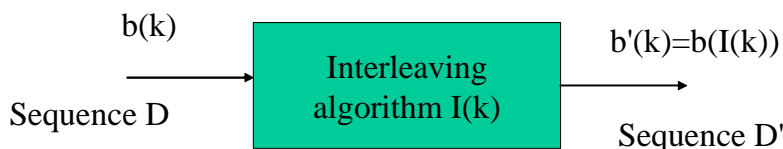

**Figure I.5: Inner interleaving rule principle**

The interleaver reads data from the input sequence and writes to the output sequence  $D'$  the interleaved bit.

Letting  $[X]_K$  denotes the  $X$  modulo  $K$  arithmetic, the simple RP interleaver is defined by:

$$I(k) = [s + kp]_K \quad k = \{0, \dots, K-1\} \quad (\text{Equation I.18})$$

$$|I(k+1) - I(k)| = \{p, (K-p)\}$$

Where  $p$  and  $K$  are relative prime.  $K$  corresponds to the initial sequence size  $D$  and  $p$  is adjusted to  $p = M' + 1 = 6$ . The value  $s$  corresponds to an offset that is set to  $s = 0$ .

Thus, the RP interleaver is a generic interleaving which is completely defined by the choice of  $p$ . The choice of  $p$  is imposed by the constraint length of the recursive encoder in the turbo-code structure FOCTC. The dispersion of the interleaver which corresponds to the difference of initial position index between adjacent interleaved bits (see equation 1.18) is defined by 2 values.  $p$  is the most frequent value otherwise, the dispersion  $\Delta I(k)$  is given by  $K-p$ .

For any block size  $K$  multiple of  $M'$ , the RP interleaver with  $p = M' + 1 = 6$  fulfils the inner interleaving constraint imposed by the FOCTC turbo-code structure (equation I.1). In the next clause, we define a procedure to generate appropriate inner interleaving patterns in case of block size which is not a multiple of  $M'$ .

#### 1.1.2.4 FOCTC Inner interleaving size adaptation to all Physical Packet Formats

The FOCTC structure is a self-terminating trellis scheme without additional tail bits which imposes that the block size  $K$  of the inner interleaving is a multiple of the constraint length  $M'$  of the encoder (equation I.1). For some configurations of the full-slot and half-slot structures this constraint is not fulfilled, as the block size of encoded bits after puncturing is imposed by the B-field data framing.

In order to maintain the interleaving rule I.1 and I.2, the input sequence  $D$  is extended with  $(K_{new} - K)$  "0" at the beginning of the sequence in a such a way that  $K_{new}$  is a multiple of  $M'$ .

$$K_{new} > K$$

$$K_{new} = M' \cdot n \quad (\text{Equation I.19a})$$

Studies from the ENST-Brest prove that the performance is enhanced if the block size  $K$  is a multiple of  $2M'$ , meaning that  $n$  has to be a even-number.

Thus, the basic sequence length  $K$  is extended to  $K_{new}$  and the  $(K_{new} - K)$  bits set to "0" are added to the initial sequence. The new sequence  $D_{new}$  is fed to the encoder RCE supplying the parity bits  $Y_{new}$ . The first  $(K_{new} - K)$  bits are punctured.

On this new sequence  $D_{new}$  the interleaving constraint rules are applied in a such a way that the first  $(K_{new} - K)$  bits are not interleaved in order to further puncturing the resulted encoded bits  $Y(k)$  and  $Y'(k)$  after RCE encoding processing.



Thus the new interleaving rule for the new block size  $K_{new}$  is given by:

$$\begin{aligned}
 K_{new} &= n \cdot M' \\
 d'(k) &= d(k) \quad k = \{0, \dots, (K_{new} - K) - 1\} \\
 d'(k) &= d(I'(k)) \quad k = \{(K_{new} - K), \dots, K_{new} - 1\} \\
 &\text{with} \\
 I'(k) &= (K_{new} - K) + I(k - (K_{new} - K)) \text{ with } k = \{(K_{new} - K), \dots, K_{new} - 1\} \\
 I(k) &= [s + p \cdot k]_K
 \end{aligned}
 \tag{Equation I.19b}$$

for  $k = \{0, \dots, K_{new} - K - 1\}$ .

- $I'(k)$  is an identity function.

For the  $k$ -values ranged from  $k = \{K_{new} - K, \dots, K_{new} - 1\}$ :

- $I'(k)$  is deduced from the RP interleaver procedure explained in the previous clause with  $k = \{0, \dots, K - 1\}$  conducting to  $I(k)$ .
- $I'(k)$  is then simply obtained from a sum of  $I(k)$  and an offset  $(K_{new} - K)$  (equation I.19b).

Figure I.6 illustrates the inner interleaving size adaptation processing.

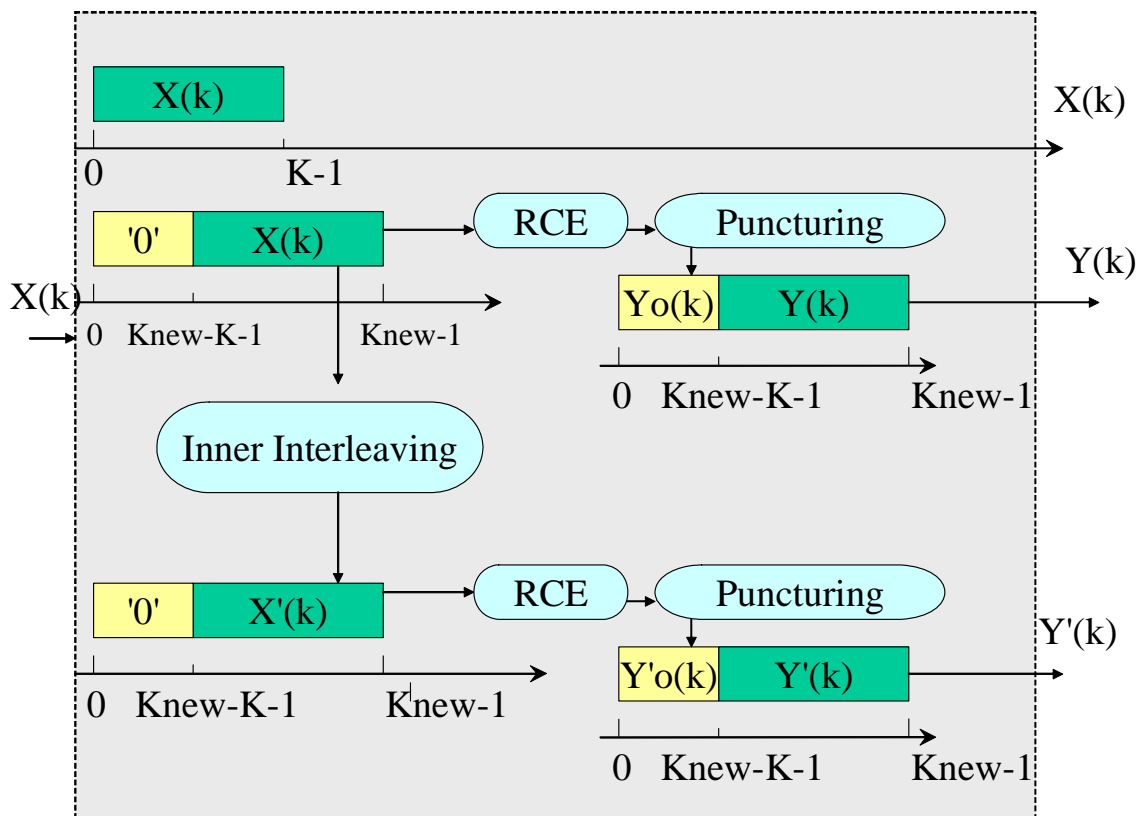

**Figure I.6: Inner Interleaving size adaptation of the FOCTC structure**

The output of the FOCTC structure is ordered as follow:

$$x(k) \ y(k) \ y'(k) \ x(k+1) \ y(k+1) \ y'(k+1), \dots, x(k+p) \ y(k+p) \ y'(k+p) \tag{Equation I.19c}$$

The sequence composed of  $3K$  bits is punctured (see clause I.2.2) to process B-field mapping.

## I.2 Adaptive coding and Modulation Embodiment

A combined adaptive coding and modulation is performed in order to fit the adaptive code rate  $r = K/B$  ( $K$ : useful bit block size before encoding) and the block-size of encoded bit  $B$ :

- to the time-slot structure;
- to the modulation level;
- to the propagation channel characteristics; and
- to the services.

Various adaptive code rates are performed by puncturing the turbo mother code having a code rate  $r_{\text{fix}} = 1/3$ . Puncturing patterns are associated to the bit-mapping which specifies the bit position of various punctured bits  $X, Y, Y'$  within successive symbols. This repartition conducts to a periodic bit-mapping pattern. The bit-mapping pattern is built under constraints defined by Siaud (see [i.7]). Figure I.6 shows the coding process whereby the following equations apply:

$$B = K / r \quad (\text{Equation I.20})$$

- $r$ : Adaptive code rate.
- $K$ : Block size of the useful bit at the encoder input; Size of the inner interleaving matrix in the FOCTC encoder.
- $B$ : B-field; Block size of the encoded bits at the encoder output.

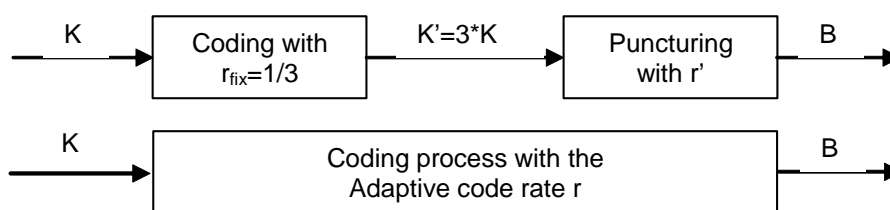

Figure I.7: Adaptive code rate  $r$

### I.2.1 Adaptive code rates

Table I.1 provides 6 propagation scenarios in indoor and outdoor environments. The propagation scenarios are divided into three groups under LOS/OLOS/NLOS conditions:

- Group 1: LOS conditions;
- Group 2: OLOS conditions;
- Group 3: NLOS conditions.

For each group two modes are defined distinguishing two distance ranges of the radio link:

- Mode A: distance range  $d < 50$  m;
- Mode B:  $50 \text{ m} < \text{distance range } d < 100$  m.

The resulting propagation scenarios are shown in table I.1.

Table I.1: Propagation scenarios

|        | LOS    | OLOS   | NLOS   |
|--------|--------|--------|--------|
| Mode A | Case 1 | Case 3 | Case 5 |
| Mode B | Case 2 | Case 4 | Case 6 |

The net bit rate depends on the modulation scheme, the propagation scenarios and the adaptive code rate. Different adaptive code rates are proposed in order to provide various net bit rates and to cover different services.

Tables I.2 to I.4 define the possible modulation schemes, propagation scenarios, adaptive code rates and the resulting data net bit rates.

NOTE: The bit rates calculated in the following clauses are based on a symbol rate of 1 152 kSymbol/s. Later standardization may extend the symbol rate to 3 456 kSymbol/s.

### I.2.1.1 Adaptive code rates for the double slot structure (physical packet P80)

The B-field mapping shall be in the Encoded Protected format (see clause 6).

The data net bit rate for the physical packet P80 is calculated as shown in equation I.20a.

$$\text{Data net bit rate } Du = \frac{\text{usefulBits\_perFrame}}{\text{FrameDuration}} = \frac{\text{usefulBits\_perSlot} \times \text{Slots\_perFrame}}{\text{FrameDuration}} = \frac{\frac{K \text{ bits}}{\text{Slot}} \times \frac{12 \text{ Slot}}{\text{Frame}}}{0,01 \text{ s}} = 1,2 \times K \text{ kbps} \quad (\text{Equation I.20a})$$

**Table I.2: Adaptive code rates for the physical packet P80**

| Modulation | Configuration | B-field size (bits) | Case 1                 |                            |                                 | Case 2                 |                            |                                 |
|------------|---------------|---------------------|------------------------|----------------------------|---------------------------------|------------------------|----------------------------|---------------------------------|
|            |               |                     | Adaptive code rate $r$ | Useful bits $K=B \times r$ | Data net bit rate $Du$ (kbit/s) | Adaptive code rate $r$ | Useful bits $K=B \times r$ | Data net bit rate $Du$ (kbit/s) |
| GMSK, DBSK | 1a, 1b        | 800                 | 1,0                    | 800                        | 960,0                           | 1,0                    | 800                        | 960,0                           |
| DQPSK      | 2, 4a         | 1 600               | 1,0                    | 1 600                      | 1 920,0                         | 0,8                    | 1 280                      | 1 536,0                         |
| D8PSK      | 3, 4b         | 2 400               | 0,8                    | 1 920                      | 2 304,0                         | 0,8                    | 1 920                      | 2 304,0                         |
| 16QAM      | 5             | 3 200               | 0,8                    | 2 560                      | 3 072,0                         | 0,8                    | 2 560                      | 3 072,0                         |
| 64QAM      | 6             | 4 800               | 0,8                    | 3 840                      | 4 608,0                         | 0,75                   | 3 600                      | 4 320,0                         |
| Modulation | Configuration | B-field size (bits) | Case 3                 |                            |                                 | Case 4                 |                            |                                 |
|            |               |                     | Adaptive code rate $r$ | Useful bits $K=B \times r$ | Data net bit rate $Du$ (kbit/s) | Adaptive code rate $r$ | Useful bits $K=B \times r$ | Data net bit rate $Du$ (kbit/s) |
| GMSK, DBSK | 1a, 1b        | 800                 | 1,0                    | 800                        | 960,0                           | 0,8                    | 640                        | 768,0                           |
| DQPSK      | 2, 4a         | 1 600               | 0,8                    | 1 280                      | 1 536,0                         | 0,75                   | 1 200                      | 1 440,0                         |
| D8PSK      | 3, 4b         | 2 400               | 0,8                    | 1 920                      | 2 304,0                         | 0,75                   | 1 800                      | 2 160,0                         |
| 16QAM      | 5             | 3 200               | 0,75                   | 2 400                      | 2 880,0                         | 0,6                    | 1 920                      | 2 304,0                         |
| 64QAM      | 6             | 4 800               | 0,6                    | 2 880                      | 3 456,0                         | 0,5                    | 2 400                      | 2 880,0                         |
| Modulation | Configuration | B-field size (bits) | Case 5                 |                            |                                 | Case 6                 |                            |                                 |
|            |               |                     | Adaptive code rate $r$ | Useful bits $K=B \times r$ | Data net bit rate $Du$ (kbit/s) | Adaptive code rate $r$ | Useful bits $K=B \times r$ | Data net bit rate $Du$ (kbit/s) |
| GMSK, DBSK | 1a, 1b        | 800                 | 0,75                   | 600                        | 720,0                           | 0,75                   | 600                        | 720,0                           |
| DQPSK      | 2, 4a         | 1 600               | 0,6                    | 960                        | 1 152,0                         | 0,5                    | 800                        | 960,0                           |
| D8PSK      | 3, 4b         | 2 400               | 0,6                    | 1 440                      | 1 728,0                         | 0,5                    | 1 200                      | 1 440,0                         |
| 16QAM      | 5             | 3 200               | 0,5                    | 1 600                      | 1 920,0                         | 0,4                    | 1 280                      | 1 536,0                         |
| 64QAM      | 6             | 4 800               | 0,4                    | 1 920                      | 2 304,0                         | 1/3                    | 1 600                      | 1 919,8                         |

NOTE: For example in table I.2, Case 1, Configuration 6, describes: In order to run a 4,6 Mbit/s-service in a Case 1 environment, a 64 QAM modulation with an adaptive code rate  $r = 0,8$  should be used.

### I.2.1.2 Adaptive code rates for the full slot structure (physical packet P32)

The B-field mapping shall be in the Encoded protected format (see clause 6).

The data net bit rate for the physical packet P32 is calculated as shown in equation I.21.

$$Data\ net\ bit\ rate\ Du = \frac{usefulBits\_perFrame}{FrameDuration} = \frac{usefulBits\_perSlot \times Slots\_perFrame}{FrameDuration} = \frac{\frac{K\ bits}{Slot} \times \frac{24\ Slot}{Frame}}{\frac{0,01\ s}{Frame}} = 2,4 \times K\ kbps \quad (Equation\ I.21)$$

**Table I.3: Adaptive code rates for the physical packet P32**

| Modulation | Configuration | B-field size (bits) | Case 1                 |                            |                                 | Case 2                 |                            |                                 |
|------------|---------------|---------------------|------------------------|----------------------------|---------------------------------|------------------------|----------------------------|---------------------------------|
|            |               |                     | Adaptive code rate $r$ | Useful bits $K=B \times r$ | Data net bit rate $Du$ (kbit/s) | Adaptive code rate $r$ | Useful bits $K=B \times r$ | Data net bit rate $Du$ (kbit/s) |
| GMSK, DBSK | 1a, 1b        | 320                 | 1,0                    | 320                        | 768,0                           | 1,0                    | 320                        | 768,0                           |
| DQPSK      | 2, 4a         | 640                 | 1,0                    | 640                        | 1 536,0                         | 0,8                    | 512                        | 1 228,8                         |
| D8PSK      | 3, 4b         | 960                 | 0,8                    | 768                        | 1 843,2                         | 0,8                    | 768                        | 1 843,2                         |
| 16QAM      | 5             | 1 280               | 0,8                    | 1 024                      | 2 457,6                         | 0,8                    | 1 024                      | 2 457,6                         |
| 64QAM      | 6             | 1 920               | 0,8                    | 1 536                      | 3 686,4                         | 0,75                   | 1 440                      | 3 456,0                         |
| Modulation | Configuration | B-field size (bits) | Case 3                 |                            |                                 | Case 4                 |                            |                                 |
|            |               |                     | Adaptive code rate $r$ | Useful bits $K=B \times r$ | Data net bit rate $Du$ (kbit/s) | Adaptive code rate $r$ | Useful bits $K=B \times r$ | Data net bit rate $Du$ (kbit/s) |
| GMSK, DBSK | 1a, 1b        | 320                 | 1,0                    | 320                        | 768,0                           | 0,8                    | 256                        | 614,4                           |
| DQPSK      | 2, 4a         | 640                 | 0,8                    | 512                        | 1 228,8                         | 0,75                   | 480                        | 1 152,0                         |
| D8PSK      | 3, 4b         | 960                 | 0,8                    | 768                        | 1 843,2                         | 0,75                   | 720                        | 1 728,0                         |
| 16QAM      | 5             | 1 280               | 0,75                   | 960                        | 2 304,0                         | 0,6                    | 768                        | 1 843,2                         |
| 64QAM      | 6             | 1 920               | 0,6                    | 1 152                      | 2 764,8                         | 0,5                    | 960                        | 2 304,0                         |
| Modulation | Configuration | B-field size (bits) | Case 5                 |                            |                                 | Case 6                 |                            |                                 |
|            |               |                     | Adaptive code rate $r$ | Useful bits $K=B \times r$ | Data net bit rate $Du$ (kbit/s) | Adaptive code rate $r$ | Useful bits $K=B \times r$ | Data net bit rate $Du$ (kbit/s) |
| GMSK, DBSK | 1a, 1b        | 320                 | 0,75                   | 240                        | 576,0                           | 0,75                   | 240                        | 576,0                           |
| DQPSK      | 2, 4a         | 640                 | 0,6                    | 384                        | 921,6                           | 0,5                    | 320                        | 768,0                           |
| D8PSK      | 3, 4b         | 960                 | 0,6                    | 576                        | 1 382,4                         | 0,5                    | 480                        | 1 152,0                         |
| 16QAM      | 5             | 1 280               | 0,5                    | 640                        | 1 536,0                         | 0,4                    | 512                        | 1 228,8                         |
| 64QAM      | 6             | 1 920               | 0,4                    | 768                        | 1 843,2                         | 1/3                    | 640                        | 1 534,5                         |

### I.2.1.3 Adaptive code rates for the half slot structure (physical packet P00j with j=80)

The B-field mapping shall be in the Encoded protected format (see clause 6).

The data net bit rate for the physical packet P00j (j=80) is calculated as shown in equation I.22.

$$Data\ net\ bit\ rate\ Du = \frac{usefulBits\_perFrame}{FrameDuration} = \frac{usefulBits\_perSlot \times Slots\_perFrame}{FrameDuration} = \frac{\frac{K\ bits}{Slot} \times \frac{48\ Slot}{Frame}}{\frac{0,01\ s}{Frame}} = 4,8 \times K\ kbps \quad (Equation\ I.22)$$

Table I.4: Adaptive code rates for the physical packet P00j (j=80)

| Modulation | Configuration | B-field size (bits) | Case 1               |                   |                               | Case 2               |                   |                               |
|------------|---------------|---------------------|----------------------|-------------------|-------------------------------|----------------------|-------------------|-------------------------------|
|            |               |                     | Adaptive code rate r | Useful bits K=Bxr | Data net bit rate Du (kbit/s) | Adaptive code rate r | Useful bits K=Bxr | Data net bit rate Du (kbit/s) |
| GMSK, DBSK | 1a, 1b        | 80                  | 1,0                  | 80                | 384,0                         | 1,0                  | 80                | 384,0                         |
| DQPSK      | 2, 4a         | 160                 | 1,0                  | 160               | 768,0                         | 0,8                  | 128               | 614,4                         |
| D8PSK      | 3, 4b         | 240                 | 0,8                  | 192               | 921,6                         | 0,8                  | 192               | 921,6                         |
| 16QAM      | 5             | 320                 | 0,8                  | 256               | 1 228,8                       | 0,8                  | 256               | 1 228,8                       |
| 64QAM      | 6             | 480                 | 0,8                  | 384               | 1 843,2                       | 0,75                 | 360               | 1 728,0                       |
| Modulation | Configuration | B-field size (bits) | Case 3               |                   |                               | Case 4               |                   |                               |
|            |               |                     | Adaptive code rate r | Useful bits K=Bxr | Data net bit rate Du (kbit/s) | Adaptive code rate r | Useful bits K=Bxr | Data net bit rate Du (kbit/s) |
| GMSK, DBSK | 1a, 1b        | 80                  | 1,0                  | 80                | 384,0                         | 0,8                  | 64                | 307,2                         |
| DQPSK      | 2, 4a         | 160                 | 0,8                  | 128               | 614,4                         | 0,75                 | 120               | 576,0                         |
| D8PSK      | 3, 4b         | 240                 | 0,8                  | 192               | 921,6                         | 0,75                 | 180               | 864,0                         |
| 16QAM      | 5             | 320                 | 0,75                 | 240               | 1 152,0                       | 0,6                  | 192               | 921,6                         |
| 64QAM      | 6             | 480                 | 0,6                  | 288               | 1 382,4                       | 0,5                  | 240               | 1 152,0                       |
| Modulation | Configuration | B-field size (bits) | Case 5               |                   |                               | Case 6               |                   |                               |
|            |               |                     | Adaptive code rate r | Useful bits K=Bxr | Data net bit rate Du (kbit/s) | Adaptive code rate r | Useful bits K=Bxr | Data net bit rate Du (kbit/s) |
| GMSK, DBSK | 1a, 1b        | 80                  | 0,75                 | 60                | 288,0                         | 0,75                 | 60                | 288,0                         |
| DQPSK      | 2, 4a         | 160                 | 0,6                  | 96                | 460,8                         | 0,5                  | 80                | 384,0                         |
| D8PSK      | 3, 4b         | 240                 | 0,6                  | 144               | 691,2                         | 0,5                  | 144               | 576,0                         |
| 16QAM      | 5             | 320                 | 0,5                  | 160               | 768,0                         | 0,4                  | 128               | 614,4                         |
| 64QAM      | 6             | 480                 | 0,4                  | 192               | 921,6                         | 1/3                  | 160               | 767,2                         |

NOTE: The data net bit rate for double, full and half slot structure may also be calculated as shown in equation I.23. The following abbreviations apply:

Ds: Symbol rate set to 1 152 kSymbol/s (could be set to 3 456 kSymbol/s for further standardization)

K: Number of useful bits per time slot

NB: Number of B field bits

N: Number of bits per time slot

r: Adaptive code rate.

$$Data\ net\ bit\ rate\ Du = K \times \frac{Ds}{N_{bits\_per\_time\_slot}} = \frac{NB_{field\_bits\_per\_time\_slot} \times r}{N_{bits\_per\_time\_slot}} \times Ds \quad (\text{Equation I.23})$$

## 1.2.2 Puncturing patterns

Puncturing patterns have to be defined for each adaptive code rate defined in tables I.2 to I.4. Puncturing is defined from a mother code rate set to  $r_{fix} = 1/3$  (see clause I.1.1) and is dimensioned upon the modulation level as described by Siau (see [i.7]). The optimized puncturing is defined for the different B-field mappings, giving the positions of encoded bits X, Y, Y' in successive symbols.

The code rate  $r=1/3 = 0,333$  does not require any puncturing.

Encoded bits are located in each symbol under a specific bit-mapping pattern. Useful bits are with priority set as MSB, while parity bits are set as LSB. The key feature of the puncturing pattern consists of building the puncturing matrix in respect with this rule, depending on both modulation and punctured adaptive code rate. This rule conducts to a bit-mapping pattern which is derived from puncturing.

Table I.5: Puncturing patterns for each adaptive code rate and its modulation

| Puncturing pattern leading to bit-mapping pattern |                                         |                               |                     |                                                              |
|---------------------------------------------------|-----------------------------------------|-------------------------------|---------------------|--------------------------------------------------------------|
| Adaptive Code Rate r                              | Modulation                              | encoded block length N (bits) | Number of punctures | Index of punctured bits i={1,...,N}                          |
| 0,8                                               | GMSK, DBPSK, DQPSK, D8PSK, 16QAM, 64QAM | 24                            | 14                  | {3, 5, 8, 9, 11, 12, 14, 15, 17, 18, 20, 21, 23, 24}         |
| 0,75                                              | GMSK, BPSK, DQPSK, D8PSK, 16QAM, 64QAM  | 27                            | 15                  | {3, 5, 8, 9, 11, 12, 14, 15, 17, 18, 20, 21, 23, 26, 27}     |
| 0,6                                               | GMSK, DBPSK, DQPSK, 16QAM               | 36                            | 16                  | {3, 5, 8, 9, 11, 12, 15, 17, 21, 24, 26, 27, 29, 30, 32, 35} |
| 0,6                                               | D8PSK, 64QAM                            | 36                            | 16                  | {3, 5, 8, 9, 12, 15, 17, 20, 21, 24, 26, 27, 29, 30, 32, 36} |
| 0,5                                               | GMSK, DBPSK, DQPSK, D8PSK, 16QAM, 64QAM | 6                             | 2                   | {3, 5}                                                       |
| 0,4                                               | GMSK, DBPSK, DQPSK, D8PSK, 16QAM, 64QAM | 12                            | 2                   | {5, 12}                                                      |

### I.2.3 Channel Capacity for the B-field map configurations

The channel capacity for the physical packet P80, P32 and P00j (j=80) is calculated as shown in equation (I.24).

$$\text{Channel capacity } I = \frac{\text{usefulBits}_{\text{perFrame}}}{\text{FrameDuration}} = \frac{\text{usefulBits}_{\text{perSlot}} \times \text{Slots}_{\text{perFrame}}}{\text{FrameDuration}} = \frac{\frac{K \text{ bits}}{\text{Slot}} \times \frac{1 \text{ Slot}}{\text{Frame}}}{\frac{0,01 \text{ s}}{\text{Frame}}} = 0,1 \times K \text{ kbps} \quad (\text{Equation I.24})$$

#### I.2.3.1 Double Slot Structure

The B-field mapping shall be in the Encoded protected format (see clause 6).

Table I.6: Adaptive code rates for the physical packet P80

| Modulation | Configuration | B-field size (bits) | Case 1               |                   |                             | Case 2               |                   |                             |
|------------|---------------|---------------------|----------------------|-------------------|-----------------------------|----------------------|-------------------|-----------------------------|
|            |               |                     | Adaptive code rate r | Useful bits K=B×r | Channel capacity I (kbit/s) | Adaptive code rate r | Useful bits K=B×r | Channel capacity I (kbit/s) |
| GMSK, DBSK | 1a, 1b        | 800                 | 1,0                  | 800               | 80,0                        | 1,0                  | 800               | 80,0                        |
| DQPSK      | 2, 4a         | 1 600               | 1,0                  | 1 600             | 160,0                       | 0,8                  | 1 280             | 128,0                       |
| D8PSK      | 3, 4b         | 2 400               | 0,8                  | 1 920             | 192,0                       | 0,8                  | 1 920             | 192,0                       |
| 16QAM      | 5             | 3 200               | 0,8                  | 2 560             | 256,0                       | 0,8                  | 2 560             | 256,0                       |
| 64QAM      | 6             | 4 800               | 0,8                  | 3 840             | 384,0                       | 0,75                 | 3 600             | 360,0                       |
| Modulation | Configuration | B-field size (bits) | Case 3               |                   |                             | Case 4               |                   |                             |
|            |               |                     | Adaptive code rate r | Useful bits K=B×r | Channel capacity I (kbit/s) | Adaptive code rate r | Useful bits K=B×r | Channel capacity I (kbit/s) |
| GMSK, DBSK | 1a, 1b        | 800                 | 1,0                  | 800               | 80,0                        | 0,8                  | 640               | 64,0                        |
| DQPSK      | 2, 4a         | 1 600               | 0,8                  | 1 280             | 128,0                       | 0,75                 | 1 200             | 120,0                       |
| D8PSK      | 3, 4b         | 2 400               | 0,8                  | 1 920             | 192,0                       | 0,75                 | 1 800             | 180,0                       |
| 16QAM      | 5             | 3 200               | 0,75                 | 2 400             | 240,0                       | 0,6                  | 1 920             | 192,0                       |
| 64QAM      | 6             | 4 800               | 0,6                  | 2 880             | 288,0                       | 0,5                  | 2 400             | 240,0                       |

| Modulation | Configuration | B-field size (bits) | Case 5                 |                            |                               | Case 6                 |                            |                               |
|------------|---------------|---------------------|------------------------|----------------------------|-------------------------------|------------------------|----------------------------|-------------------------------|
|            |               |                     | Adaptive code rate $r$ | Useful bits $K=B \times r$ | Channel capacity $I$ (kbit/s) | Adaptive code rate $r$ | Useful bits $K=B \times r$ | Channel capacity $I$ (kbit/s) |
| GMSK, DBSK | 1a, 1b        | 800                 | 0,75                   | 600                        | 60,0                          | 0,75                   | 600                        | 60,0                          |
| DQPSK      | 2, 4a         | 1 600               | 0,6                    | 960                        | 96,0                          | 0,5                    | 800                        | 80,0                          |
| D8PSK      | 3, 4b         | 2 400               | 0,6                    | 1 440                      | 144,0                         | 0,5                    | 1 200                      | 120,0                         |
| 16QAM      | 5             | 3 200               | 0,5                    | 1 600                      | 160,0                         | 0,4                    | 1 280                      | 128,0                         |
| 64QAM      | 6             | 4 800               | 0,4                    | 1 920                      | 192,0                         | 1/3                    | 1 600                      | 160,0                         |

### I.2.3.2 Full Slot Structure

The B-field mapping shall be in the Encoded protected format (see clause 6).

**Table I.7: Adaptive code rates for the physical packet P32**

| Modulation | Configuration | B-field size (bits) | Case 1                 |                            |                               | Case 2                 |                            |                               |
|------------|---------------|---------------------|------------------------|----------------------------|-------------------------------|------------------------|----------------------------|-------------------------------|
|            |               |                     | Adaptive code rate $r$ | Useful bits $K=B \times r$ | Channel capacity $I$ (kbit/s) | Adaptive code rate $r$ | Useful bits $K=B \times r$ | Channel capacity $I$ (kbit/s) |
| GMSK, DBSK | 1a, 1b        | 320                 | 1,0                    | 320                        | 32,0                          | 1,0                    | 320                        | 32,0                          |
| DQPSK      | 2, 4a         | 640                 | 1,0                    | 640                        | 64,0                          | 0,8                    | 512                        | 51,2                          |
| D8PSK      | 3, 4b         | 960                 | 0,8                    | 768                        | 76,8                          | 0,8                    | 768                        | 76,8                          |
| 16QAM      | 5             | 1 280               | 0,8                    | 1 024                      | 102,4                         | 0,8                    | 1 024                      | 102,4                         |
| 64QAM      | 6             | 1 920               | 0,8                    | 1 536                      | 153,6                         | 0,75                   | 1 440                      | 144,0                         |
| Modulation | Configuration | B-field size (bits) | Case 3                 |                            |                               | Case 4                 |                            |                               |
|            |               |                     | Adaptive code rate $r$ | Useful bits $K=B \times r$ | Channel capacity $I$ (kbit/s) | Adaptive code rate $r$ | Useful bits $K=B \times r$ | Channel capacity $I$ (kbit/s) |
| GMSK, DBSK | 1a, 1b        | 320                 | 1,0                    | 320                        | 32,0                          | 0,8                    | 256                        | 25,6                          |
| DQPSK      | 2, 4a         | 640                 | 0,8                    | 512                        | 51,2                          | 0,75                   | 480                        | 48,0                          |
| D8PSK      | 3, 4b         | 960                 | 0,8                    | 768                        | 76,8                          | 0,75                   | 720                        | 72,0                          |
| 16QAM      | 5             | 1 280               | 0,75                   | 960                        | 96,0                          | 0,6                    | 768                        | 76,8                          |
| 64QAM      | 6             | 1 920               | 0,6                    | 1 152                      | 115,2                         | 0,5                    | 960                        | 96,0                          |
| Modulation | Configuration | B-field size (bits) | Case 5                 |                            |                               | Case 6                 |                            |                               |
|            |               |                     | Adaptive code rate $r$ | Useful bits $K=B \times r$ | Channel capacity $I$ (kbit/s) | Adaptive code rate $r$ | Useful bits $K=B \times r$ | Channel capacity $I$ (kbit/s) |
| GMSK, DBSK | 1a, 1b        | 320                 | 0,75                   | 240                        | 24,0                          | 0,75                   | 240                        | 24,0                          |
| DQPSK      | 2, 4a         | 640                 | 0,6                    | 384                        | 38,4                          | 0,5                    | 320                        | 32,0                          |
| D8PSK      | 3, 4b         | 960                 | 0,6                    | 576                        | 57,6                          | 0,5                    | 480                        | 48,0                          |
| 16QAM      | 5             | 1 280               | 0,5                    | 640                        | 64,0                          | 0,4                    | 512                        | 51,2                          |
| 64QAM      | 6             | 1 920               | 0,4                    | 768                        | 76,8                          | 1/3                    | 640                        | 64,0                          |

### I.2.3.3 Half Slot Structure

The B-field mapping shall be in the Encoded protected format (see clause 6).

**Table I.8**

| Modulation | Configuration | B-field size (bits) | Case 1                 |                            |                             | Case 2                 |                            |                             |
|------------|---------------|---------------------|------------------------|----------------------------|-----------------------------|------------------------|----------------------------|-----------------------------|
|            |               |                     | Adaptive code rate $r$ | Useful bits $K=B \times r$ | Channel capacity I (kbit/s) | Adaptive code rate $r$ | Useful bits $K=B \times r$ | Channel capacity I (kbit/s) |
| GMSK, DBSK | 1a, 1b        | 80                  | 1,0                    | 80                         | 8,0                         | 1,0                    | 80                         | 8,0                         |
| DQPSK      | 2, 4a         | 160                 | 1,0                    | 160                        | 16,0                        | 0,8                    | 128                        | 12,8                        |
| D8PSK      | 3, 4b         | 240                 | 0,8                    | 192                        | 19,2                        | 0,8                    | 192                        | 19,2                        |
| 16QAM      | 5             | 320                 | 0,8                    | 256                        | 25,6                        | 0,8                    | 256                        | 25,6                        |
| 64QAM      | 6             | 480                 | 0,8                    | 384                        | 38,4                        | 0,75                   | 360                        | 36,0                        |
| Modulation | Configuration | B-field size (bits) | Case 3                 |                            |                             | Case 4                 |                            |                             |
|            |               |                     | Adaptive code rate $r$ | Useful bits $K=B \times r$ | Channel capacity I (kbit/s) | Adaptive code rate $r$ | Useful bits $K=B \times r$ | Channel capacity I (kbit/s) |
| GMSK, DBSK | 1a, 1b        | 80                  | 1                      | 8,0                        | 8,0                         | 0,8                    | 64                         | 6,4                         |
| DQPSK      | 2, 4a         | 160                 | 0,8                    | 128                        | 12,8                        | 0,75                   | 120                        | 12,0                        |
| D8PSK      | 3, 4b         | 240                 | 0,8                    | 192                        | 19,2                        | 0,75                   | 180                        | 18,0                        |
| 16QAM      | 5             | 320                 | 0,75                   | 240                        | 24,0                        | 0,6                    | 192                        | 19,2                        |
| 64QAM      | 6             | 480                 | 0,6                    | 288                        | 28,8                        | 0,5                    | 240                        | 24,0                        |
| Modulation | Configuration | B-field size (bits) | Case 5                 |                            |                             | Case 6                 |                            |                             |
|            |               |                     | Adaptive code rate $r$ | Useful bits $K=B \times r$ | Channel capacity I (kbit/s) | Adaptive code rate $r$ | Useful bits $K=B \times r$ | Channel capacity I (kbit/s) |
| GMSK, DBSK | 1a, 1b        | 80                  | 0,75                   | 60                         | 6,0                         | 0,75                   | 60                         | 6,0                         |
| DQPSK      | 2, 4a         | 160                 | 0,6                    | 96                         | 9,6                         | 0,5                    | 80                         | 8,0                         |
| D8PSK      | 3, 4b         | 240                 | 0,6                    | 144                        | 14,4                        | 0,5                    | 120                        | 12,0                        |
| 16QAM      | 5             | 320                 | 0,5                    | 160                        | 16,0                        | 0,4                    | 128                        | 12,8                        |
| 64QAM      | 6             | 480                 | 0,4                    | 192                        | 19,2                        | 1/3                    | 160                        | 16,0                        |

## I.3 Change Modulation Scheme

All bearers of a MAC connection shall always be setup using the default modulation scheme.

The modulation type modification shall be handled as described in clause 10.3.4.

Each modulation type is identified in the attributes\_T\_Req message by its slot type, modulation level and adaptive code rate.

## I.4 B-Field Binary Interleaving

### I.4.1 General description

The block interleaving algorithm  $L(k)$  denoted Turbo-Like interleaver ([i.9]) is a generic algebraic algorithm applied to protected B-field encoded bits described for the physical packet formats (P32, P80 and P00j with  $j=80$ ) detailed in clause 6.2.1.3.2. Interleaving is applied after the channel coding and puncturing described in clauses I.1 and I.2.2 respectively. The turbo-Like interleaver is completely determined with 4 interleaving parameters  $\{K, p, q, j\}$  where  $K$  is the block interleaving size and  $\{p, q, j\}$  are integers providing the desired interleaving patterns associated with  $K$ .



The block interleaver has an iterative structure found out with the parameter (j) associated with the iteration. An illustration of the structure is given on the figure I.7a. The elementary interleaver module I(k) integrated in the iterative loop is expressed thanks to 2 algebraic functions ( $L_{0,p}$  and  $L_{1,p,q}$ ) characterized with 2 inputs and one output. Interleaver parameters  $\{K,p,q,j\}$  are adjusted to the modulation level and B-field block sizes in compliance with the Physical Packet formats.

The proposed binary interleaving algorithm has several fundamental properties.

First, it is characterized by an iterative structure similar as the turbo based transmitter structure composed of two parallel inputs and a single output. One of the input is fed with the initial binary index position of the input S sequence and the second one is fed with the interleaving output of the previous iteration. The interleaving iteration (j) may contribute to a modification of the interleaving spreading and interleaving patterns (clause I.4.2).

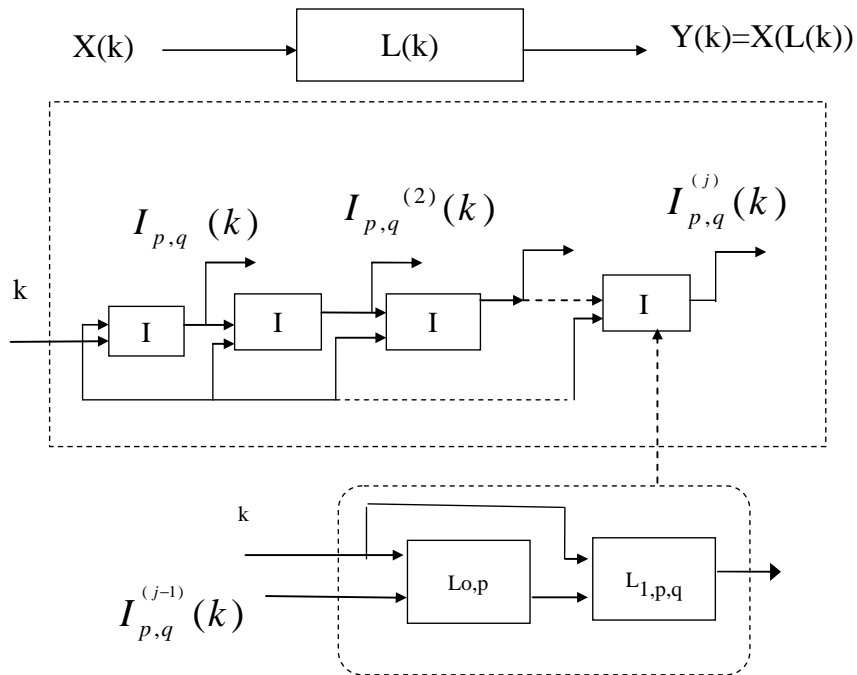

**Figure I.7a: The interleaving turbo structure principle**

Secondly, the Turbo-Like interleaver controls the interleaving spreading in an algebraic way in order to generate appropriate interleaving patterns in accordance with a multi-level interleaving spreading maximization criterion. The interleaving spreading denoted  $\Delta L(s)$ , is the minimum distance between sample indexes separated by s-1 samples at the interleaving output with  $\Delta L(s) = \text{Min}_{0 \leq k \leq K-1} \{ |L(k+s) - L(k)| \}$ . Multi-level interleaving spreading maximization is very applied to optimise the distance between adjacent bits within every symbol and between adjacent symbols [i.9]. Interleaving spreading is illustrated on the figure I.8.

Thirdly, the algorithm keeps unchanged an *elementary partitioning pattern* formed with p virtual data streams where p is one parameter of the interleaver. Preserving a binary *elementary partitioning pattern* means that interleaved bits keep unchanged the p data stream ordering within every binary *elementary partitioning pattern* after the interleaving processing. Interleaving is then compatible with special multi-stream multiplexing. The i-th bit after the interleaving processing is still associated to the i-th data stream in the *elementary partitioning pattern* composed of p bits. The algorithm is equivalent to a multi-parallel interleaving algorithm composed of p interleavers that is performed using L(k) on a single stream with a lower complexity implementation. This property is mathematically translated by the equation (I.25) and illustrated on figure I.8:

$$I^{(j)}(k) - k = Q(k) \times p. \quad (\text{Equation I.25})$$

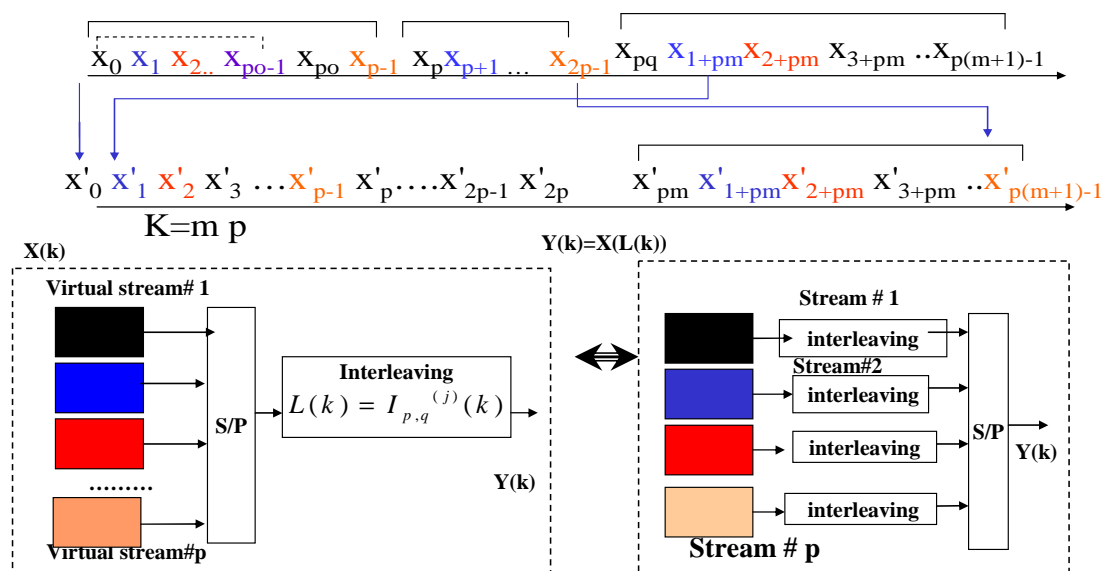

Figure I.8: The equivalent multi-stream interleaving processing

## 1.4.2 Mathematical Description

The interleaving algorithm  $L(k) = I_{p,q}^{(j)}(k)$  is described by 4 parameters:

- an integer parameter  $p$  setting the *elementary partitioning size*;
- an integer parameter  $q$  modifying the interleaving spreading;
- the bloc size  $K$ ;
- the iteration ( $j$ ) of the algorithm modifying the interleaving spreading.

### 1.4.2.1 $L(k)$ Expression

$I_{p,q}^{(j)}(k)$  is based on an interleaving function  $L(k)$ , built on a serial combination of two algebraic functions  $L_{0,p}$  and  $L_{1,p,q}$ , characterized by two inputs and one output. Inputs of the function  $L_{0,p}$  are fed with the input index position and the feedback of the previous iteration of the algorithm,  $I_{p,q}^{(j-1)}(k)$ , while function  $L_{1,p,q}$  is fed with the incremental  $k$  (position index of samples  $0, 1, \dots, K-1$ ) and the output of the function  $L_{0,p}$  associated with the current iteration.

$L_0$  and  $L_1$  functions are expressed, for  $j=1$ , as follow:

$$\begin{aligned}
 L_{0,p}(k) &= [-k - k \cdot p]_K, \quad k = \{0, \dots, K-1\} \\
 I_{p,q}(k) &= L_{1,p,q}(k) = [K - p + k + q \cdot p \cdot L_{0,p}(k)]_K \\
 I_{p,q}(k) &= [K - p + k + q \cdot p \cdot [-k - kp]_K]_K
 \end{aligned}
 \tag{Equation I.26}$$

The operation  $[X]_K$  is the  $X$  modulo- $K$  arithmetic operation, i.e. the rest of the division of  $X$  by  $K$  where  $K$  is the B-field size composed on encoded punctured bits as detailed in the clause I.2.3.

The interleaving algorithm expressed for the iteration  $j=2$  as:

$$\begin{aligned}
 L_{0,p}^{(2)}(k) &= \left[ -k - p \cdot I_{p,q}(k) \right]_K \\
 I_{p,q}^{(2)}(k) &= \left[ K - p + k + p \cdot q \cdot L_{0,p}^{(2)}(k) \right]_K \\
 I_{p,q}^{(2)}(k) &= \left[ K - p + k + p \cdot q \cdot \left[ -k - p \cdot I_{p,q}(k) \right]_K \right]_K
 \end{aligned}
 \tag{Equation I.27}$$

The extension to the  $j$ -th iteration is given by:

$$\begin{aligned}
 L_{0,p}^{(j)}(k) &= \left[ -k - p \cdot I_{p,q}^{(j-1)}(k) \right]_K \\
 I_{p,q}^{(j)}(k) &= \left[ K - p + k + q \cdot p \cdot L_{0,p}^{(j)}(k) \right]_K \\
 I_{p,q}^{(j)}(k) &= \left[ K - p + k + q \cdot p \cdot \left[ -k - p \cdot I_{p,q}^{(j-1)}(k) \right]_K \right]_K
 \end{aligned}
 \tag{Equation I.28}$$

### 1.4.2.2 Interleaving Spreading $\Delta L(s)$ Expression

The interleaving spreading  $\Delta L(s) = \text{Min}_{0 \leq k < K} \{ |L(k+s) - L(k)| \}$  between samples separated with  $s-1$  samples corresponds to lowest absolute value of the dispersion  $P_L(s, k) = L(k+s) - L(k)$  and the function  $K - |P_L(s, k)|$  when  $k$  varies from 0 to  $K-1$ . An illustration is given on the figure I.8.

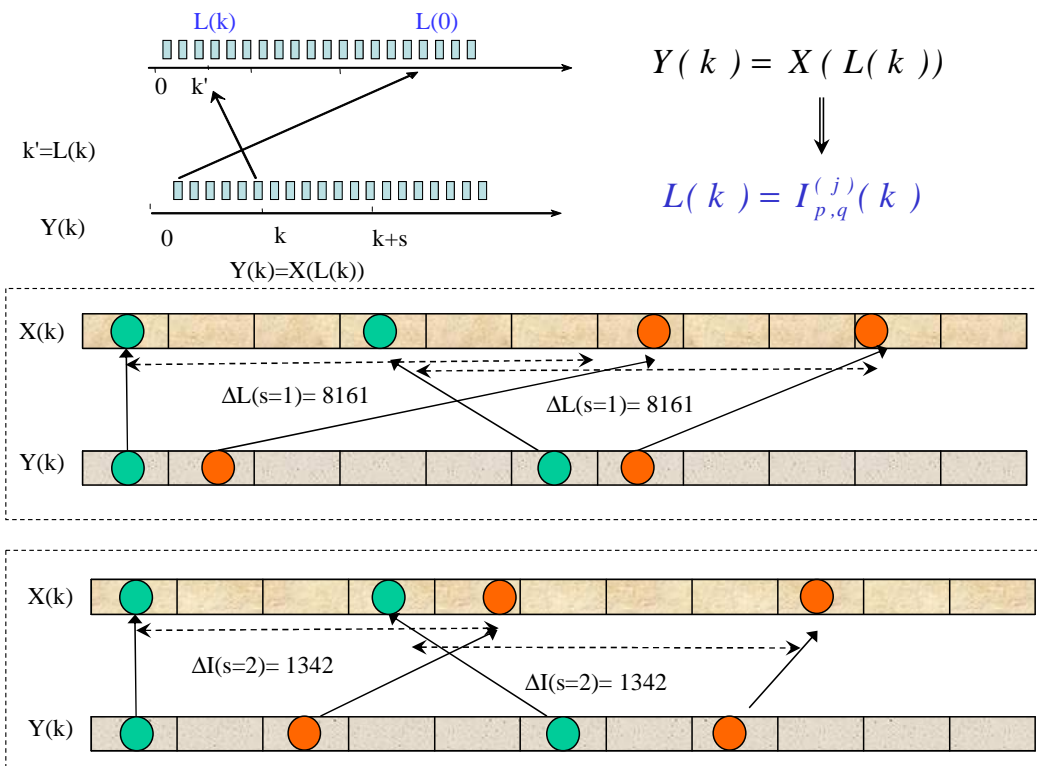

Figure I.9: Interleaving spreading definition and notations

$\Delta L(s)$  may be algebraically calculated using the algebraic expression of  $L(k)$ . We use it to select optimized interleaving parameters associated with the interleaving block  $L(k)$  with a size  $K$ .

The interleaving spreading for the first iteration (j=1) is given by  $\Delta_{eff} I_{p,q}(s)$ :

$$\begin{aligned} P_{p,q}(s) &= I_{p,q}(k+s) - I_{p,q}(k), \\ \Delta_{eff} I_{p,q}(s) &= \text{Min}\{|P_{p,q}(s)|, K - |P_{p,q}(s)|\} \\ I_{p,q}(k) &= \left[ K - p + k + q \cdot p \cdot [-k - p \cdot k] \right]_K \\ I_{p,q}(k+s) &= \left[ K - p + k + s + q \cdot p \cdot [-(k+s) - p \cdot (k+s)] \right]_K \\ P_{p,q}(s) &= s - [q \cdot p \cdot s(p+1)]_K \end{aligned} \quad (\text{Equation I.29})$$

$$\Delta_{eff} I_{p,q}(s) = \text{Min} \left\{ \begin{array}{l} |s - [q \cdot p \cdot s(p+1)]_K|, \\ |K - |s - [q \cdot p \cdot s(p+1)]_K|| \end{array} \right\} \quad (\text{Equation I.30})$$

For the iteration j, we have:

$$\begin{aligned} P_{j,p,q}(s) &= I_{p,q}^{(j)}(k+s) - I_{p,q}^{(j)}(k) \\ P_{j,p,q}(s) &= s - [q \cdot p \cdot (s + p \cdot P_{j-1,p,q}(s))]_K \end{aligned} \quad (\text{Equation I.31})$$

$$\begin{aligned} \Delta_{eff} I_{p,q}^{(j)}(s) &= \text{Min} \left\{ |P_{j,p,q,s}(k)|, |K - |P_{j,p,q,s}(k)|| \right\} \\ \Delta_{eff} I_{p,q}^{(j)}(s) &= \text{Min} \left\{ \begin{array}{l} |s - [q \cdot p \cdot (s + p \cdot P_{j-1,p,q}(s))]_K|, \\ |K - |s - [q \cdot p \cdot (s + p \cdot P_{j-1,p,q}(s))]_K|| \end{array} \right\} \end{aligned} \quad (\text{Equation I.32})$$

These algebraic functions are used to select the most outstanding binary interleaving parameters of each K-size binary interleaving block using the algorithm L(k) (equation I.26, I.27, I.28). Selected parameters {p,q,j} correspond to an interleaving spreading maximization within every symbols and between symbols as detailed in the clause I.4.3.

### 1.4.3 B-field binary interleaving parameters

Interleaving processing applied after channel coding (see clause I.1) is applied to encoded protected formats as detailed in the clause 6.2.1.3.2.

For each B-Field mapping and Physical Packet formats, this section provides the most outstanding interleaving parameters providing an efficient B-field map interleaving pattern increasing both interleaving within every symbol (s=1) and between adjacent symbols (s=m) with m corresponding to the number of bits per symbol. The corresponding interleaving spreading  $\Delta L(s)$  between adjacent bits and bits separated by s-1 bits associated are given in tables I.9 to I.11.

The constraint of the interleaver imposes that the interleaving block size K is multiple of the parameter p supplying the bit *elementary partitioning pattern* size.

#### 1.4.3.1 Physical packet Format P80 (double slot structure)

Interleaving parameters and interleaving spreading for the Physical packet Format P80 configurations are indicated in the table I.9.

**Table I.9: Interleaving parameters and interleaving spreading for the Physical packet Format P80**

| B-field mapping |                | Interleaving parameters |    |   | Interleaving Spreading |               | Optimised Interleaving parameters |
|-----------------|----------------|-------------------------|----|---|------------------------|---------------|-----------------------------------|
| Configuration   | B-field size K | s=m                     | p  | q | $\Delta L(s=1)$        | $\Delta L(m)$ | {p,q,i}                           |
| GMSK, DBPSK     | 800            | 1                       | 10 | 2 | 219                    | 219           | {10,2,1}                          |
| DQPSK           | 1 600          | 2                       | 20 | 2 | 761                    | 722           | {20,2,3}                          |
| D8PSK           | 2 400          | 3                       | 15 | 2 | 479                    | 963           | {15,2,1}                          |
| 16-QAM          | 3 200          | 4                       | 20 | 2 | 839                    | 956           | {20,2,3}                          |
| 64-QAM          | 4 800          | 6                       | 60 | 2 | 2 281                  | 1 686         | {60,2,3}                          |

### I.4.3.2 Physical packet Format P32 (full slot structure)

Interleaving parameters and interleaving spreading for the Physical packet Format P32 configurations are indicated in the table I.10.

**Table I.10: Interleaving parameters and interleaving spreading for the Physical packet Format P32**

| B-field mapping |                | Interleaving parameters |     |   | Interleaving Spreading |               | Interleaving parameters |
|-----------------|----------------|-------------------------|-----|---|------------------------|---------------|-------------------------|
| Configuration   | B-field size K | s=m                     | p   | q | $\Delta L(s=1)$        | $\Delta L(m)$ | {p,q,i}                 |
| GMSK, DBPSK     | 320            | 1                       | 20  | 2 | 121                    | 121           | {20,2,1}                |
| DQPSK           | 640            | 2                       | 80  | 2 | 159                    | 318           | {80,2,1}                |
| D8PSK           | 960            | 3                       | 15  | 2 | 479                    | 477           | {15,2,1}                |
| 16-QAM          | 1 280          | 4                       | 40  | 2 | 561                    | 324           | {40,2,3}                |
| 64-QAM          | 1 920          | 6                       | 240 | 2 | 479                    | 954           | {240,2,1}               |

### I.4.3.3 Physical packet Format P00j with j=80 (Half-Slot structure)

Interleaving parameters and interleaving spreading for the Physical packet Format P00j with j=80 are indicated in the table I.11

**Table I.11: Interleaving parameters and interleaving spreading for the Physical packet Format P00j with j=80**

| B-field mapping |                | Interleaving parameters |    |   | Interleaving Spreading |               | Interleaving parameters |
|-----------------|----------------|-------------------------|----|---|------------------------|---------------|-------------------------|
| Configuration   | B-field size K | s=m                     | p  | q | $\Delta l(s=1)$        | $\Delta l(m)$ | {p,q,i}                 |
| GMSK, DBPSK     | 80             | 1                       | 20 | 2 | 39                     | 39            | {20,2,1}                |
| DQPSK           | 160            | 2                       | 20 | 2 | 39                     | 78            | {20,2,1}                |
| D8PSK           | 240            | 3                       | 60 | 2 | 119                    | 117           | {60,2,1}                |
| 16-QAM          | 320            | 4                       | 20 | 2 | 121                    | 156           | {20,2,1}                |
| 64-QAM          | 480            | 6                       | 60 | 2 | 119                    | 234           | {60,2,1}                |

The interleaving parameters and interleaving spreading for the Physical packet Format P00j with j values other than j=80 are for further study.

## Annex J (informative): Channel decoding

The decoder 2 uses the extrinsic information issued from the decoder 1 to decode encoded bits  $Y_k^2$  sent to decoder 2 input. An iterative processing of this basic concept significantly improves the performance. The Turbo Code Decoder structure is shown in figure J.1.

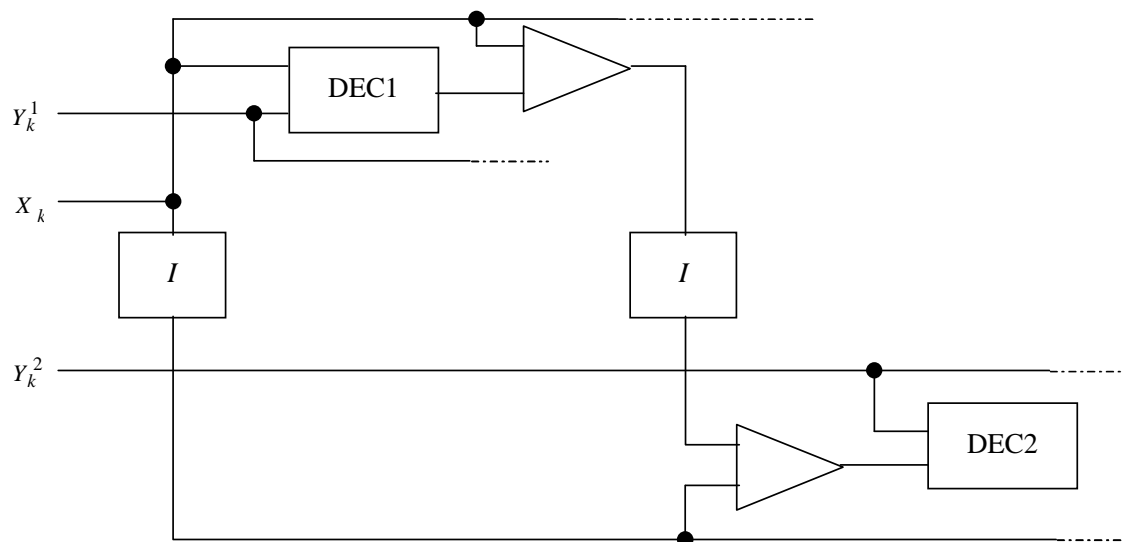

Figure J.1: Turbo Code Decoder structure

## Annex K (informative): Additional information on MAC messages

### K.1 Historic use of some MAC service codes

MAC Service codes (defined in clause 7.2.5.3.8, table 7.32) were reviewed in 2008 and some codes were re-allocated in order to allow future expansion. The definition of the codes until revision V2.1.1 of the present document was as follows.

Table K.1

| Ser type/Max life                     |                 |                 |                 |                 |                 | Service type                                   |
|---------------------------------------|-----------------|-----------------|-----------------|-----------------|-----------------|------------------------------------------------|
| a <sub>26</sub>                       | a <sub>27</sub> | a <sub>28</sub> | a <sub>29</sub> | a <sub>30</sub> | a <sub>31</sub> |                                                |
| 0                                     | 0               | 0               | 0               | 0               | 0               | I <sub>N</sub> _minimum_delay                  |
| 0                                     | 0               | 1               | 0               | 0               | 0               | I <sub>N</sub> _normal_delay                   |
| 0                                     | 1               | 0               | 0               | 0               | 0               | I <sub>P</sub> _error_detection                |
| 0                                     | 1               | 1               | L               | L               | L               | I <sub>P</sub> , MAC modulo-2 error correction |
| 1                                     | 0               | 0               | 0               | 0               | 0               | unknown                                        |
| 1                                     | 0               | 1               | 0               | 0               | 0               | C channel only                                 |
| 1                                     | 1               | 0               | 0               | 0               | 0               | I <sub>PQ</sub> _error_detection               |
| 1                                     | 1               | 1               | L               | L               | L               | I <sub>PQ</sub> MAC modulo 2 error correction  |
| 0                                     | 0               | 0               | 0               | 0               | 1               | I <sub>P</sub> encoded protected               |
| All other values                      |                 |                 |                 |                 |                 | reserved                                       |
| L = Maximum lifetime, see table 7.32a |                 |                 |                 |                 |                 |                                                |

NOTE: There is no difference for GAP (EN 300 444 [i.8]) compliant products (code "000000" = I<sub>N</sub>\_minimum\_delay (I<sub>NA</sub>) remains unchanged).

---

## Annex L (informative): Bibliography

- ETSI ETR 042: "Digital Enhanced Cordless Telecommunications (DECT); A guide to DECT features that influence the traffic capacity and the maintenance of high radio link transmission quality, including the results of simulations".
- CEPT Recommendation T/SGT SF2 (89) 6/0: "Draft Recommendation T/SF Services and Facilities of Digital European Cordless Telecommunications".
- J.L. Ramsey: "Realization of optimum interleavers", IEEE Trans. Information Theory, Vol.IT-16, n 3, pp. 338-345, May 1970.
- G.D. Forney: "Burst-correcting codes for the classic burst channel", IEEE Trans. Comm. Technologies, vol-COM-19, pp. 772-781, October 1971.
- ETSI TS 102 527-1: "Digital Enhanced Cordless Telecommunications (DECT); New Generation DECT Part 1: Wideband speech".
- ETSI TS 102 527-2: "Digital Enhanced Cordless Telecommunications (DECT); New Generation DECT Part 2: Support of transparent IP packet data".
- ETSI TS 102 527-3: "Digital Enhanced Cordless Telecommunications (DECT); New Generation DECT Part 3: Extended wideband speech services".



## Annex M (informative): Change history

The following table presents main changes from a published version to the next version (published or to be published).

| Subject/Comment                                                                                                                                                                                                                                                                                                                                                                                                                                                              | Old   | New   |
|------------------------------------------------------------------------------------------------------------------------------------------------------------------------------------------------------------------------------------------------------------------------------------------------------------------------------------------------------------------------------------------------------------------------------------------------------------------------------|-------|-------|
| The enhancement of the DECT base standard to support higher data rates includes the 16 QAM/64 QAM modulation option and the Channel Coding based on the Turbo Code Principle.                                                                                                                                                                                                                                                                                                | 1.6.1 | 1.7.1 |
| No changes - just compatible versions alignment with the other parts.                                                                                                                                                                                                                                                                                                                                                                                                        | 1.7.1 | 1.8.1 |
| Qt message added to indicate transmission information; some minor editorials.                                                                                                                                                                                                                                                                                                                                                                                                | 1.8.1 | 1.9.1 |
| New Generation DECT: A major revision of the DECT base standard introducing wideband speech, improved data services, new slot types and other technical enhancements.                                                                                                                                                                                                                                                                                                        | 1.9.1 | 2.1.1 |
| New E+U mux mode and I <sub>PF</sub> channel; New Listening for setup modes; New functionality in M channel messages: MAC resume page, GF channel and Null; New ECN change procedure. New procedure for "no-emission" mode. Reviewed descriptions for: Bearer setup procedures; MAC MOD-2 I channel operation; I <sub>N</sub> and I <sub>P_error_detect</sub> operation; Advanced > basic connection change procedure; Service change procedure; Bandwidth change procedure. | 2.1.1 | 2.2.1 |
| Clarification in "no-emission" mode; Preamble coding for "no-emission" mode DummyRequest; Rekeying and default cipher key.                                                                                                                                                                                                                                                                                                                                                   | 2.2.1 | 2.3.1 |
| New authentication algorithm DSAA2 and new ciphering algorithm DSC2. New interleaving schema in Turbocoding (annex I). No emission-mode. New High Level Modulation schemes. New MAC services I <sub>PK</sub> and I <sub>PKR</sub> and new constant-size subfield format. Editorial review.                                                                                                                                                                                   | 2.3.1 | 2.4.1 |
| Introduction of DECT ULE: New advanced connection expedited messages and C/O procedures; New C/L, synchronization and paging procedures; New channel selection algorithms and procedures; New MAC channel G <sub>FA</sub> ; Review of Q1/Q2/BCK bit codings with detailed rules for E-mux and no B-field modes.                                                                                                                                                              | 2.4.1 | 2.5.1 |

## History

| <b>Document history</b> |                |                                                             |
|-------------------------|----------------|-------------------------------------------------------------|
| Edition 1               | October 1992   | Publication as ETS 300 175-3 (Historical)                   |
| Edition 2               | September 1996 | Publication as ETS 300 175-3 (Historical)                   |
| V1.4.2                  | June 1999      | Publication                                                 |
| V1.5.1                  | February 2001  | Publication                                                 |
| V1.6.1                  | January 2002   | Publication                                                 |
| V1.7.1                  | July 2003      | Publication                                                 |
| V1.8.1                  | November 2004  | Publication                                                 |
| V1.9.1                  | September 2005 | Publication                                                 |
| V2.1.1                  | August 2007    | Publication                                                 |
| V2.2.1                  | November 2008  | Publication                                                 |
| V2.3.1                  | June 2010      | Publication                                                 |
| V2.4.1                  | April 2012     | Publication                                                 |
| V2.5.0                  | April 2013     | EN Approval Procedure AP 20130820: 2013-04-22 to 2013-08-20 |