

Final draft **ETSI EN 300 175-1** V2.3.0 (2010-02)

---

*European Standard (Telecommunications series)*

**Digital Enhanced Cordless Telecommunications (DECT);  
Common Interface (CI);  
Part 1: Overview**

---

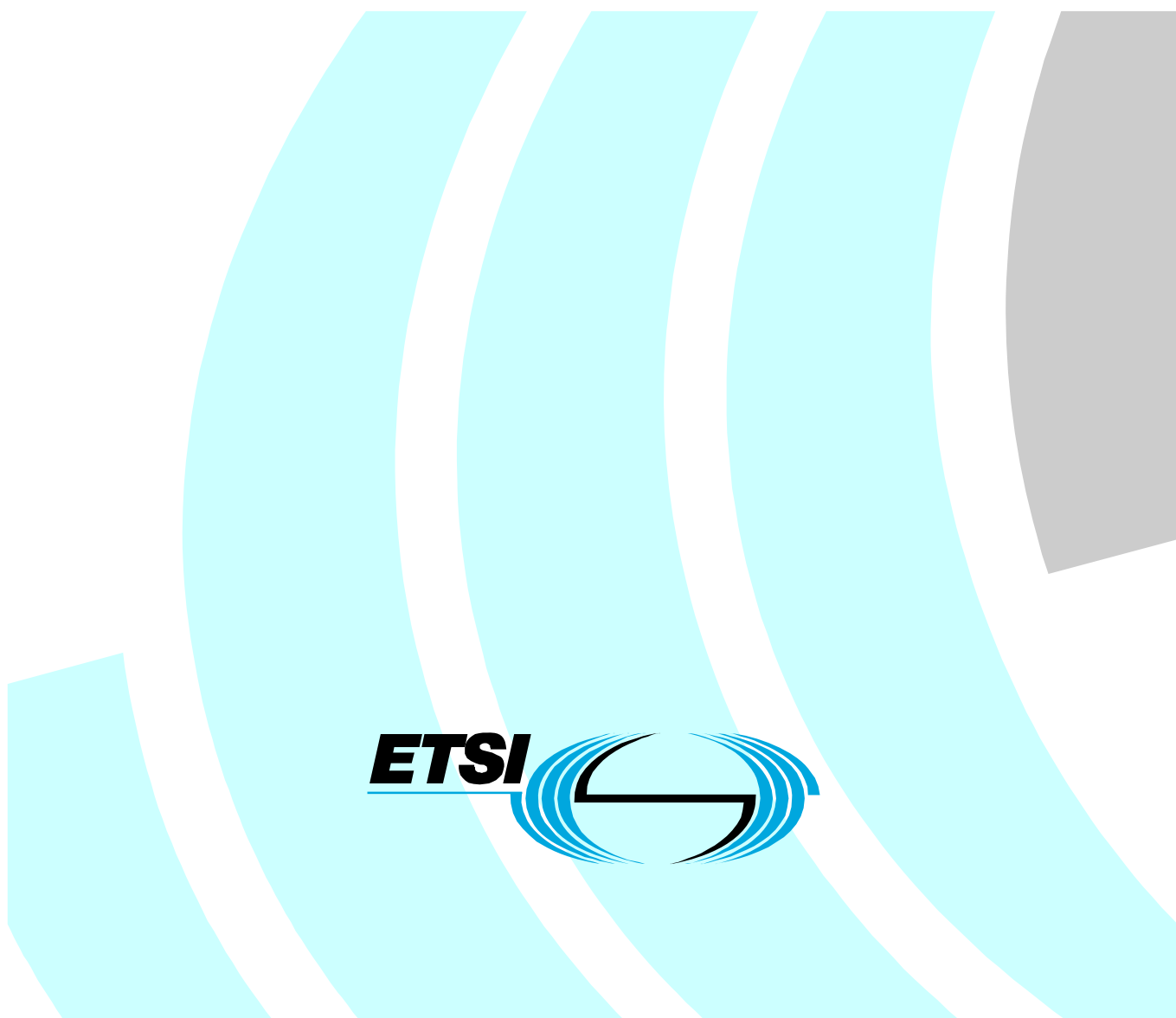

---

Reference

REN/DECT-000254-1

---

Keywords

7 kHz, audio, broadband, CODEC, DECT, handsfree, IMT-2000, loudspeaking, mobility, narrowband, quality, radio, speech, TDD, TDMA, telephony, terminal

**ETSI**

650 Route des Lucioles  
F-06921 Sophia Antipolis Cedex - FRANCE

Tel.: +33 4 92 94 42 00 Fax: +33 4 93 65 47 16

Siret N° 348 623 562 00017 - NAF 742 C  
Association à but non lucratif enregistrée à la  
Sous-Préfecture de Grasse (06) N° 7803/88

---

**Important notice**

Individual copies of the present document can be downloaded from:

<http://www.etsi.org>

The present document may be made available in more than one electronic version or in print. In any case of existing or perceived difference in contents between such versions, the reference version is the Portable Document Format (PDF). In case of dispute, the reference shall be the printing on ETSI printers of the PDF version kept on a specific network drive within ETSI Secretariat.

Users of the present document should be aware that the document may be subject to revision or change of status. Information on the current status of this and other ETSI documents is available at

<http://portal.etsi.org/tb/status/status.asp>

If you find errors in the present document, please send your comment to one of the following services:

[http://portal.etsi.org/chaicor/ETSI\\_support.asp](http://portal.etsi.org/chaicor/ETSI_support.asp)

---

**Copyright Notification**

No part may be reproduced except as authorized by written permission.  
The copyright and the foregoing restriction extend to reproduction in all media.

© European Telecommunications Standards Institute 2010.  
All rights reserved.

**DECT™**, **PLUGTESTS™**, **UMTS™**, **TIPHON™**, the TIPHON logo and the ETSI logo are Trade Marks of ETSI registered for the benefit of its Members.

**3GPP™** is a Trade Mark of ETSI registered for the benefit of its Members and of the 3GPP Organizational Partners.

**LTE™** is a Trade Mark of ETSI currently being registered

for the benefit of its Members and of the 3GPP Organizational Partners.

**GSM®** and the GSM logo are Trade Marks registered and owned by the GSM Association.

---

# Contents

|   |           |
|---|-----------|
| Intellectual Property Rights .....                        | 4         |
| Foreword.....   | 4         |
| 1 Scope .....   | 5         |
| 2 References .....  | 5         |
| 2.1 Normative references .....                            | 5         |
| 2.2 Informative references.....                           | 6         |
| 3 Definitions, symbols and abbreviations .....            | 7         |
| 3.1 Definitions.....                                      | 7         |
| 3.2 Symbols and abbreviations.....                        | 14        |
| 4 Structure .....   | 19        |
| 4.1 Part 1: Overview.....                                 | 20        |
| 4.2 Part 2: Physical Layer (PHL) .....                    | 20        |
| 4.3 Part 3: Medium Access Control (MAC) layer.....        | 20        |
| 4.4 Part 4: Data Link Control (DLC) layer.....            | 20        |
| 4.5 Part 5: Network (NWK) layer .....                     | 20        |
| 4.6 Part 6: Identities and addressing.....                | 20        |
| 4.7 Part 7: Security features .....                       | 20        |
| 4.8 Part 8: Speech and audio coding and transmission..... | 21        |
| 5 The objectives of the CI standard.....                  | 21        |
| 6 General description of the system .....                 | 22        |
| 7 Description of the protocol architecture .....          | 23        |
| 7.1 General .....   | 23        |
| 7.2 The DECT layered structure.....                       | 23        |
| 7.3 Physical Layer (PHL).....                             | 24        |
| 7.4 MAC layer.....  | 24        |
| 7.5 DLC layer .....                                       | 25        |
| 7.6 Network (NWK) layer.....                              | 25        |
| 7.7 Lower Layer Management Entity (LLME) .....            | 25        |
| 7.8 Interworking Units (IWU).....                         | 26        |
| 8 Proprietary escapes within the CI.....                  | 26        |
| 8.1 Primary escape routes.....                            | 26        |
| 8.2 Secondary escape routes.....                          | 27        |
| 9 Levels of conformance .....                             | 27        |
| <b>Annex A (informative): Bibliography.....</b>           | <b>28</b> |
| <b>Annex B (informative): Change history .....</b>        | <b>29</b> |
| History .....   | 30        |

---

## Intellectual Property Rights

IPRs essential or potentially essential to the present document may have been declared to ETSI. The information pertaining to these essential IPRs, if any, is publicly available for **ETSI members and non-members**, and can be found in ETSI SR 000 314: "*Intellectual Property Rights (IPRs); Essential, or potentially Essential, IPRs notified to ETSI in respect of ETSI standards*", which is available from the ETSI Secretariat. Latest updates are available on the ETSI Web server (<http://webapp.etsi.org/IPR/home.asp>).

Pursuant to the ETSI IPR Policy, no investigation, including IPR searches, has been carried out by ETSI. No guarantee can be given as to the existence of other IPRs not referenced in ETSI SR 000 314 (or the updates on the ETSI Web server) which are, or may be, or may become, essential to the present document.

---

## Foreword

This European Standard (Telecommunications series) has been produced by ETSI Technical Committee Digital Enhanced Cordless Telecommunications (DECT), and is now submitted for the ETSI standards One-step Approval Procedure.

The present document is part 1 of a multi-part deliverable covering the Common Interface (CI) for the Digital Enhanced Cordless Telecommunications (DECT), as identified below:

- Part 1: "Overview";**
- Part 2: "Physical Layer (PHL)";
- Part 3: "Medium Access Control (MAC) layer";
- Part 4: "Data Link Control (DLC) layer";
- Part 5: "Network (NWK) layer";
- Part 6: "Identities and addressing";
- Part 7: "Security features";
- Part 8: "Speech and audio coding and transmission".

The following aspects of the present document are subject to controlled distribution:

- a) DECT identities, as defined in EN 300 175-6 [6];
- b) DECT cryptographic algorithms.

The cryptographic algorithms specify the details of the DECT standard authentication algorithm and the DECT standard cipher.

These aspects are distributed on an individual basis. Further information and details of the current distribution procedures can be obtained from the ETSI Secretariat at the address on the second page of the present document.

Further details of the DECT system may be found in TR 101 178 [i.4], ETR 043 [i.5] and TR 102 185 [i.6].

| <b>Proposed national transposition dates</b>   |                                 |
|--|---------------------------------|
| Date of latest announcement of this EN (doa):  | 3 months after ETSI publication |
| Date of latest publication of new National Standard or endorsement of this EN (dop/e): | 6 months after doa              |
| Date of withdrawal of any conflicting National Standard (dow):                         | 6 months after doa              |

---

# 1 Scope

The present document gives an introduction and overview of the complete Digital Enhanced Cordless Telecommunications (DECT) Common Interface (CI).

The present document contains an abstract of the other parts of the DECT standard together with a general description of:

- the objectives of the present document;
- the DECT Common Interface;
- the protocol architecture of DECT.

The present document also provides an extensive vocabulary; in particular it contains the common definitions of all the technical terms used in different parts of the present document.

The present document includes New Generation DECT, a further development of the DECT standard introducing wideband speech, improved data services, new slot types and other technical enhancements.

---

# 2 References

References are either specific (identified by date of publication and/or edition number or version number) or non-specific.

- For a specific reference, subsequent revisions do not apply.
- Non-specific reference may be made only to a complete document or a part thereof and only in the following cases:
  - if it is accepted that it will be possible to use all future changes of the referenced document for the purposes of the referring document;
  - for informative references.

Referenced documents which are not found to be publicly available in the expected location might be found at <http://docbox.etsi.org/Reference>.

NOTE: While any hyperlinks included in this clause were valid at the time of publication ETSI cannot guarantee their long term validity.

## 2.1 Normative references

The following referenced documents are indispensable for the application of the present document. For dated references, only the edition cited applies. For non-specific references, the latest edition of the referenced document (including any amendments) applies.

- |     |   |
|-----|---|
| [1] | Void.   |
| [2] | ETSI EN 300 175-2: "Digital Enhanced Cordless Telecommunications (DECT); Common Interface (CI); Part 2: Physical Layer (PHL)".              |
| [3] | ETSI EN 300 175-3: "Digital Enhanced Cordless Telecommunications (DECT); Common Interface (CI); Part 3: Medium Access Control (MAC) layer". |
| [4] | ETSI EN 300 175-4: "Digital Enhanced Cordless Telecommunications (DECT); Common Interface (CI); Part 4: Data Link Control (DLC) layer".     |
| [5] | ETSI EN 300 175-5: "Digital Enhanced Cordless Telecommunications (DECT); Common Interface (CI); Part 5: Network (NWK) layer".               |

- [6] ETSI EN 300 175-6: "Digital Enhanced Cordless Telecommunications (DECT); Common Interface (CI); Part 6: Identities and addressing".
- [7] ETSI EN 300 175-7: "Digital Enhanced Cordless Telecommunications (DECT); Common Interface (CI); Part 7: Security features".
- [8] ETSI EN 300 175-8: "Digital Enhanced Cordless Telecommunications (DECT); Common Interface (CI); Part 8: Speech and audio coding and transmission".
- [9] ETSI EN 300 176 (all parts): "Digital Enhanced Cordless Telecommunications (DECT); Test specification".
- [10] ITU-R Recommendation M.1457-6: "Detailed specifications of the radio interfaces of International Mobile Telecommunications-2000 (IMT-2000)".
- [11] ETSI EN 301 649: "Digital Enhanced Cordless Telecommunications (DECT); DECT Packet Radio Service (DPRS)".

## 2.2 Informative references

The following referenced documents are not essential to the use of the present document but they assist the user with regard to a particular subject area. For non-specific references, the latest version of the referenced document (including any amendments) applies.

- [i.1] ETSI EN 300 403-1: "Integrated Services Digital Network (ISDN); Digital Subscriber Signalling System No. one (DSS1) protocol; Signalling network layer for circuit-mode basic call control; Part 1: Protocol specification [ITU-T Recommendation Q.931 (1993), modified]".
- [i.2] ITU-R Recommendation SM.1046-2: "Definition of spectrum use and efficiency of a radio system".
- [i.3] ITU-R Recommendation M.816-1: "Framework for services supported on International Mobile Telecommunications-2000 (IMT-2000)".
- [i.4] ETSI TR 101 178: "Digital Enhanced Cordless Telecommunications (DECT); A High Level Guide to the DECT Standardization".
- [i.5] ETSI ETR 043: "Digital Enhanced Cordless Telecommunications (DECT); Common Interface (CI); Services and facilities requirements specification".
- [i.6] ETSI TR 102 185: "Digital Enhanced Cordless Telecommunications (DECT); Data Services Profile (DSP); Profile overview".
- [i.7] ETSI ETR 310: "Digital Enhanced Cordless Telecommunications (DECT); Traffic capacity and spectrum requirements for multi-system and multi-service DECT applications co-existing in a common frequency band".
- [i.8] ETSI TS 102 265: "Digital Enhanced Cordless Telecommunications (DECT); DECT access to IP networks".
- [i.9] ITU-T Recommendation P.311: "Transmission characteristics for wideband (150-7000 Hz) digital handset telephones".

---

## 3 Definitions, symbols and abbreviations

### 3.1 Definitions

For the purposes of the present document, the following terms and definitions apply:

**Access Rights Class (ARC):** type of access to a DECT network, such as public, residential or private

**Access Rights Details (ARD):** unique number within one ARC

**Access Rights Identity (ARI):** globally unique identity that shows the access rights related to a service provider

NOTE: PARI = Primary ARI;  
SARI = Secondary ARI;  
TARI = Tertiary ARI.

**algorithm:** mathematical process or function that transforms an input into an output

**algorithm identifier:** designator to show which algorithm is in use, so that the correct one may be chosen

**antenna diversity:** diversity implies that the Radio Fixed Part (RFP) for each bearer independently can select different antenna properties such as gain, polarization, coverage patterns and other features that may effect the practical coverage

NOTE: A typical example is space diversity, provided by two vertically polarized antennas separated by 10 cm to 20 cm.

**asymmetric algorithm:** See public key algorithm.

**attach:** process whereby a Portable Part (PP) within the coverage area of a Fixed Part (FP) to which it has access rights, notifies the FP that it is operative

**authentication:** corroboration that an entity is the one that is claimed

**authentication of Fixed radio Termination (FT):** process whereby the identity of an FT is verified to a DECT PT

**authentication of Portable radio Termination (PT):** process whereby a DECT PT is positively verified to be a legitimate user of a particular FP

**authentication (of a subscriber):** process whereby a DECT subscriber is positively verified to be a legitimate user of a particular FP

**authentication of user:** process whereby a DECT user is positively verified to be a legitimate user of a particular FP

**bearer:** See Medium Access Control (MAC) bearer or bearer service.

**bearer handover:** internal handover process provided by the MAC layer, whereby one MAC connection can modify its underlying bearers while maintaining the service provided to the Data Link Control (DLC) layer

**bearer service:** type of telecommunication service that provides a defined capability for the transmission of signals between user-network interfaces

**broadcast:** simplex point-to-multipoint mode of transmission

**C-plane:** control plane of the DECT protocol stacks, which contains all of the internal DECT protocol control, but may also include some external user information

**call:** all of the Network (NWK) layer processes involved in one NWK layer peer-to-peer association

**cell:** domain served by a single antenna(e) system (including a leaky feeder) of one FP

**Central Control Fixed Part (CCFP):** physical grouping that contains the central elements of a FP

**centrex:** implementation of a private telecommunication network exchange that is not located on the premises of the private network operator

**Cipher Key (CK):** value that is used to determine the transformation of plaintext to ciphertext in a cryptographic algorithm

**Cipher Key (CK) generation:** process for generating cryptographic keys

**ciphertext:** output of a cryptographic algorithm

**channel:** See physical channel.

**cluster:** logical grouping of one or more cells between which bearer handover is possible

**confidentiality:** rendering information secret as ciphertext unless the capability is possessed to recover the plaintext from ciphertext

**connection:** See MAC connection.

**connection handover:** internal handover process provided by the DLC layer, whereby one set of DLC entities (C-plane and U-plane) can re-route data from one MAC connection to a second new MAC connection, while maintaining the service provided to the NWK layer

**ConnectionLess mode (C/L):** transmission mode that transfers one packet (one self contained unit) of data from one source point to one (or more) destination points in a single phase

**Connection Oriented mode (C/O):** transmission mode that transfers data from one source point to one or more destination points using a protocol based on three phases:

- "Set-up";
- "Data transfer"; and
- "Release".

**Cordless Radio Fixed Part (CRFP):** Wireless Relay Station (WRS) that provides independent bearer control to a PT and FT for relayed connections

**countermeasure:** device, instrument or procedure used to counteract or defend against a threat

**coverage area:** area over which reliable communication can be established and maintained

**cryptography:** secret writing

**Data Encryption Standard (DES):** United States Federal data encryption standard

**Data Link Control (DLC):** layer 2b of the DECT protocol stack

**decipherment:** rendering of ciphertext into plaintext

**DECT NetWork (DNW):** network that uses the DECT air interface to interconnect a local network to one or more portable applications

**DECT Standard Authentication Algorithm (DSAA):** algorithm used for authentication in DECT

**DECT Standard Cipher (DSC):** algorithm used for data encryption in DECT

**Derived Cipher Key (DCK):** Cipher Key (CK) that is established as part of the procedure used to authenticate the PT

**Default Cipher Key (DefCK):** Derived Cipher Key (DCK) that is stored in both FP and PP to be used later by MAC to immediately encrypt with connection establishment

**distributed communication:** ability of a DECT terminal to provide means for or assist direct communication between any two terminals, members of a "closed" local DECT network

**DLC broadband data link:** link that can be associated with a logical MAC connection comprising a number of MAC (physical) connections

**DLC broadcast:** simplex "connectionless" mode of transmission from the DLC broadcast entity of one FT to the DLC broadcast entities in one or more PT



**DLC data link (DLC link):** association between two DLC layer entities

**DLC frame:** format used to structure all messages that are exchanged between DLC layer peer entities

**double duplex bearer:** use of two duplex bearers (see duplex bearer) which refer to the same MAC connection, sharing their simplex bearers (see simplex bearer) for the information flow

**double-simplex bearer:** use of two simplex bearers operating in the same direction on two physical channels

**double slot:** one 12<sup>th</sup> of a TDMA frame which is used to support one high capacity physical channel

**down-link:** transmission in the direction FT to PT

**duplex bearer:** use of two simplex bearers operating in opposite directions on two physical channels

**encipherment:** rendering of plaintext into ciphertext

**End System (ES):** logical grouping that contains application processes and supports telecommunication services

**extended MAC control messages:** MAC messages of the B-field connection control set

**external handover:** process of switching a call in progress from one FP to another FP

**Fast Encryption Algorithm (FEAL algorithm):** particular encryption algorithm in the public domain

**field:** continuous region of data (i.e. adjacent bits) that jointly convey information

**fixed geometry Portable Part (PP):** PP in which the electro-acoustic transducers and their associated acoustic components are held in fixed relative positions and/or orientations during all on-line conditions and test conditions of the PP

**Fixed Part (DECT Fixed Part) (FP):** physical grouping that contains all of the elements in the DECT network between the local network and the DECT air interface

**Fixed radio Termination (FT):** logical group of functions that contains all of the DECT processes and procedures on the fixed side of the DECT air interface

**flow control:** mechanism that is used to regulate the flow of data between two peer entities

**fragment:** one of the Service Data Units (SDUs) that is produced by the process of fragmentation

**fragmentation:** process of dividing a Protocol Data Unit (PDU) into more than one SDU for delivery to a lower layer

**frame:** See TDMA frame or DLC frame.

**full slot (slot):** one 24<sup>th</sup> of a TDMA frame which is used to support one physical channel

**generic:** generalized set or general purpose set, often in the sense of basic or ordinary

**Generic Access Profile (GAP):** standard in addition to the DECT CI that ensures interoperability between FPs and PPs from different manufacturers

**geographically unique:** two FPs with the same PARI, or respectively two RFPs with the same RFPI, cannot be reached or listened to at the same geographical position

**Global NetWork (GNW):** telecommunication network capable of offering a long distance telecommunication service

**globally unique identity:** identity is unique within DECT (without geographical or other restrictions)

**guard space:** nominal interval between the end of a radio transmission in a given slot and the start of a radio transmission in the next successive slot

**half slot:** one 48<sup>th</sup> of a TDMA frame which is used to support one physical channel

**handover:** process of switching a call in progress from one physical channel to another physical channel

**handset echo:** echo, perceptible by the far-end user, resulting from the coupling between the receiving and sending directions of the handset, mostly due to acoustic coupling between transducers

**Headset PP (HPP):** headset PP is a wireless headset telephone using the DECT air interface

NOTE: A HPP usually has only one speaker and one microphone combined with a limited set of keys (e.g. call button, volume plus, and volume minus). Headsets provide the equivalent functionality of a PP with hands-free operation.

**Hybrid Part (HyP):** DECT terminal that provides FT as well as PT capabilities

**impersonation:** where one identity claims the part of another identity

**incoming call:** call received at a PP

**Integrated Services Digital Network (ISDN):** digital telecommunications infrastructure to the Consultative Committee on International Telegraphy and Telephony (CCITT) standards

**intercell handover:** switching of a call in progress from one cell to another cell

**internal call:** call between 2 users that does not make use of the local network resources

**internal handover:** handover processes that are completely internal to one FT

**International Portable User Identity (IPUI):** identity that uniquely defines one user within the domain defined by his access rights related to this IPUI

**interoperability:** capability of FPs and PPs, that enable a PP to obtain access to teleservices in more than one location area and/or from more than one operator (more than one service provider)

**interoperator roaming:** roaming between FP coverage areas of different operators (different service providers)

**InterWorking Unit (IWU):** unit that is used to interconnect subnetworks

**intracell handover:** switching of a call in progress from one physical channel of one cell to another physical channel of the same cell

**intraoperator roaming:** roaming between different FP coverage areas of the same operator (same service provider)

**isochronous:** essential characteristic of a time-scale or a signal such that the time intervals between consecutive significant instants either have the same duration or durations that are integral multiples of the shortest duration

**key management:** way in which cryptographic keys are generated, distributed and used

**Key Stream Generator (KSG):** cryptographic algorithm which produces a stream of binary digits which can be used for encipherment and decipherment

**link:** See DLC data link.

**Local Area Network (LAN):** electronic systems which are interconnected and in physical proximity to each other

**Local Network (LNW):** telecommunication network capable of offering local telecommunication services

**locally unique identity:** identity is unique within one FP or location area, depending on application

**location area:** domain in which a PP may receive (and/or make) calls as a result of a single location registration

**location registration:** process whereby the position of a DECT portable termination is determined to the level of one location area, and this position is updated in one or more databases

**logical channel:** generic term for any distinct data path

**logical connection:** association between two instances of the MAC MBC that can be used by higher layers to exchange U-plane or C-plane data

**Lower Layer Management Entity (LLME):** management entity that spans a number of lower layers, and is used to describe all control activities which do not follow the rules of layering

**Lower Tester (LT):** logical grouping that contains the test equipment, a functionally equivalent DECT PT, a functionally equivalent DECT FT and a test controller

**MAC bearer (bearer):** service element that is provided by each Cell Site Function (CSF)

**MAC connection (connection):** association between one source MAC Multi-Bearer Control (MBC) entity and one destination MAC MBC entity

**masquerading:** where one identity plays the part of, or acts as, another identity

**Medium Access Control (MAC):** layer 2a of the DECT protocol stack

**minimal MMS-message attributes:** message meta-information used in the request-to-send, etc.

**MMS-message attributes:** message meta-information

**mobility class 1:** local area applications, for which terminals are pre-registered off-air with one or more specific fixed parts, and establishment of service and user parameters is therefore implicit, according to a profile-defined list

**mobility class 2:** private and public roaming applications for which terminals may move between FPs within a given domain and for which association of service parameters is explicit at the time of service request

**multiframe:** repeating sequence of 16 successive TDMA frames, that allows low rate or sporadic information to be multiplexed (e.g. basic system information or paging)

**Multimedia Messaging Service:** generic set of commands, information elements and functionality for file/messaging service

**mutual authentication:** where two entities corroborate the identity of each other

**network (telecommunication network):** all the means of providing telecommunication services between a number of locations where the services are accessed via equipment attached to the network

**network echo:** echo, perceptible by the DECT user, resulting from reflections in the network. It is mostly due to hybrid impairments at both ends of the communication

**New Generation DECT:** further development of the DECT standard introducing wideband speech, improved data services, new slot types and other technical enhancements

**node:** point at which switching occurs

**operator (DECT operator):** individual or entity who or which is responsible for operation of one or more DECT FPs

**outgoing call:** call originating from a PP

**paging:** process of broadcasting a message from a DECT FP to one or more DECT PPs

**paging area:** domain in which the PP will be paged as a part of incoming call establishment

**PARK Length Indicator (PLI):** associates a group of FP ARIs to the PARK, by indicating how many of the first ARC + ARD bits are relevant

**Personal Identity Number (PIN):** short sequence of numbers (usually 4 to 8 digits) which may be used in an authentication process to prove identity

**phase:** one discrete part of a procedure, where the start and end of the part can be clearly identified (e.g. by the arrival or dispatch of a primitive)

**Physical (PHY):** layer 1 of the DECT protocol stack

**physical channel (channel):** simplex channel that is created by transmitting in one particular slot on one particular RF channel in successive TDMA frames

**plaintext:** information or data which is intelligible to everyone

**Portable Access Rights Key (PARK):** this states the access rights for a PP

**Portable Application (PA):** logical grouping that contains all the elements that lie beyond the DECT network boundary on the portable side

**Portable HandSet (PHS):** single physical grouping that contains all of the portable elements that are needed to provide a teleservice to the user

**Portable Part (DECT Portable Part) (PP):** physical grouping that contains all elements between the user and the DECT air interface

**Portable radio Termination (PT):** logical group of functions that contains all of the DECT processes and procedures on the portable side of the DECT air interface

**Portable User Number (PUN):** globally or locally unique number within one PUT

**Portable User Type (PUT):** this shows the numbering plan structure of a PUN

**Primary Access Rights Identity (PARI):** most frequently transmitted ARI

**primitive:** distinct (but abstract) data element that is passed between adjacent protocol layers

**private:** attribute indicating that the application of the so qualified term, e.g. a network, an equipment, a service, is offered to, or is in the interest of, a determined set of users

**proprietary algorithm:** algorithm which is the intellectual property of a legal entity

**public:** attribute indicating that the application of the so qualified term, e.g. a network, an equipment, a service, is offered to, or is in the interest of, the general public

**Public Access Profile (PAP):** profile which ensures interoperability between FPs and PPs for public access services

**public access service:** service that provides access to a public network for the general public

**public key algorithm:** cryptographic algorithm in which a different key is used for encipherment and for decipherment

**radio channel:** See RF channel or physical channel.

**radio end point:** physical grouping that contains one radio transceiver (transmitter/receiver), fixed or portable

**Radio Fixed Part (RFP):** one physical sub-group of a FP that contains all the radio end points (one or more) that are connected to a single system of antennas

**Radio Fixed Part Identity (RFPI):** identity frequently transmitted by every RFP:

- PARI;
- the RFPs local identity within that FP;
- domains for handover and location areas.

**random number:** number generated by a non-deterministic process

**registration:** See either location registration or subscription registration.

**REpeater Part (REP):** WRS that relays information within the half frame time interval

**RF carrier (carrier):** centre frequency occupied by one DECT transmission

**RF channel:** nominal range of frequencies (RF spectrum) allocated to the DECT transmissions of a single RF carrier

**roaming:** movement of a PP from one FP coverage area to another FP coverage area, where the capabilities of the FPs enable the PP to make or receive calls in both areas

**roaming service:** service which can be used in more than one FP coverage area

**RS:** value used to establish authentication session keys

NOTE: As defined in clause 4.4.3.

**Rivest, Shamir and Adleman (RSA) algorithm:** public key algorithm

**Secondary Access Rights Identity (SARI):** less frequently broadcast than the PARI

**security attribute:** protocol element indicating security services, mechanisms, processes or algorithms that are supported

**segment:** one of the pieces of data that is produced by the process of segmentation

**segmentation:** process of partitioning one SDU from a higher layer into more than one PDU

**Session Key (KS):** key which is used only for a single session

**service call:** call initiated by a DECT PT for entering of FT related service and adjustment procedures in a transparent way

**service provider (telecommunications service provider):** individual, or entity, who, or which, interfaces to the customer in providing telecommunications service

**service type A:** low speed frame relay, with a net sustainable throughput of up to 24 kbit/s, optimized for burst data, low power consumption and low complexity applications such as hand-portable equipment

**service type B:** high performance frame relay, with a net sustainable throughput of up to 552 kbit/s, optimized for high speed and low latency with burst data

**service type C:** non-transparent connection of data streams requiring Link Access Protocol (LAP) services, optimized for high reliability and low additional complexity

**service type D:** non-transparent service that supports Isochronous Data Bearer Services and is suitable for transparent transfer of isochronous data streams

**service type E:** short message transfer or paging service which may be unacknowledged or acknowledged, optimized for small SDUs, low PP complexity and ultra-low power consumption

**service type F:** application profile specifically supporting teleservices such as fax, building upon the services offered by the type A/B and C profiles, optimized for terminal simplicity, spectrum efficiency and network flexibility

**sequencing (sequence numbering):** process of adding a sequence number to a set of data packets so that the packets can be reassembled in the correct order, regardless of the order they are received

**simplex bearer:** simplex bearer is the MAC layer service that is created using one physical channel

**Single Radio Fixed Part (SRFP):** radio FP that contains only one radio end point

**stream cipher:** algorithm in which the output is combined bit by bit with plaintext to produce the ciphertext

**Subscriber Interface Module (SIM):** smart card used for authentication in GSM

**subscriber (customer):** natural person or juristic person who has subscribed to telecommunication services, and is, therefore, responsible for payment

**subscription registration:** infrequent process whereby a subscriber obtains access rights to one or more FPs

**super-wideband speech:** voice service with enhanced quality compared to ADPCM G.726 and allowing the transmission of a maximum vocal frequency of at least 14 kHz

**Supplementary Service (SS):** service that modifies or supplements a basic telecommunication service:

- 1) DECT TRANSPARENT supplementary services:
  - the service elements are unspecified within EN 300 175;
- 2) DECT STANDARD supplementary services:
  - the service elements are specified within EN 300 175 by reference to other standards;
- 3) DECT SPECIFIC supplementary services:
  - the service elements are fully specified within EN 300 175.

**switching:** process of interconnecting functional units, transmission channels or telecommunication circuits for as long as required to convey signals

**symmetric algorithm:** cryptographic algorithm in which the same key is used for both encipherment and decipherment

**synchronization:** methods used to ensure that time correspondence exists between processes to ensure that data is not repeated or lost

**synchronous:** essential characteristics of time-scales or signals such that their corresponding significant instants occur at precisely the same average rate

**synchronous transmission:** transmission using isochronous signals in which the sending and receiving instruments are operating continuously in a constant time difference between corresponding significant instants

**TDMA frame:** time-division multiplex of 10 ms duration containing 24 successive full slots

**telecommunication:** any transmission and/or emission and/or reception of signals representing signs, writings, images, and sounds or intelligence of any nature by wire, radio, optical or other electromagnetic systems

**teleservice:** type of telecommunication service that provides the complete capability, including terminal equipment functions, for communication between users, according to protocols that are established by agreement

**Tertiary Access Rights Identity (TARI):** available as a Yes/No answer upon a request including the wanted ARI, not broadcast at all

**threat:** indication of coming evil

**TPUI domain:** domain over which every TPUI is (locally) unique

**U-plane:** user plane of the DECT protocol stacks

**up link:** transmission in the direction PT to FT

**User Authentication Key (UAK):** cryptographic key held by a user to prove identity

**user (of a telecommunication network):** person or machine delegated by a subscriber (by a customer) to use the services, and/or facilities, of a telecommunication network

**variable geometry PP:** PP that allows the position and/or orientation of its electro-acoustic transducers and their associated acoustic components to be changed during all on-line conditions of the PP

**wideband speech:** voice service with enhanced quality compared to ADPCM G.726 and allowing the transmission of a vocal frequency range of at least 150 Hz to 7 kHz, and fulfilling, at least, the audio performance requirements described in the ITU-T Recommendation P.311 [i.9]

**Wireless Relay Station (WRS):** physical grouping that combines elements of both PTs and FTs to relay information on a physical channel from one DECT termination to a physical channel to another DECT termination

**XRES1:** expected response calculated by a Fixed radio Termination (FT)

**XRES2:** expected response calculated by a Portable radio Termination (PT)

**X.25:** packet switched network

## 3.2 Symbols and abbreviations

For the purposes of the present document, the following symbols and abbreviations apply:

|       |   |
|-------|---|
| A     | Algorithm                                   |
| AC    | Authentication Code                         |
| ACK   | (positive) ACKnowledgement                  |
| ACP   | Adjacent Channel Power                      |
| ADPCM | Adaptive Differential Pulse Code Modulation |
| ADU   | Adapted Data Unit                           |
| ALI   | Assigned Link Identifier                    |

|                                 |   |
|---------------------------------|---|
| A-MAP                           | A-field MAP   |
| AMCI                            | Advanced MAC Connection Identifier  |
| ANSI                            | American National Standards Institute   |
| ARC                             | Access Rights Class   |
| ARD                             | Access Rights Details   |
| ARI                             | Access Rights Identity  |
| ARQ                             | Automatic Repeat reQuest  |
| ASM                             | Assigned link identifier with Synchronous Mode  |
| BCD                             | Binary Coded Decimal  |
| BCT                             | Business Cordless Telephone   |
| B-MAP                           | B-field MAP   |
| BMC                             | Broadcast Message Control   |
| BMCI                            | Basic MAC Connection Identifier   |
| BRAT                            | Basic RATE adaption service   |
| B <sub>S</sub>                  | Slow Broadcast channel (a logical channel to the MAC layer)                               |
| C                               | higher layer control Channel (see C <sub>S</sub> and C <sub>F</sub> )                     |
| C/L                             | ConnectionLess mode   |
| C/O                             | Connection Oriented mode  |
| CBC                             | Connectionless Bearer Control   |
| CBI                             | Collective Broadcast Identifier   |
| CC                              | Call Control  |
| CCF                             | Cluster Control Function  |
| CCFP                            | Central Control Fixed Part  |
| CEP                             | Connection End Point  |
| C <sub>F</sub>                  | higher layer signalling Channel (fast)  |
| C <sub>F</sub> , C <sub>S</sub> | logical channels to the MAC layer   |
| CHO                             | Connection HandOver   |
| CHP                             | Connection Handover Pending   |
| CI                              | Cell Identity   |
| CI                              | Common Interface (standard)   |
| CISS                            | Call Independent Supplementary Services   |
| CK                              | Cipher Key  |
| CL                              | higher layer ConnectionLess channel (protected; see CL <sub>S</sub> and CL <sub>F</sub> ) |
| CL <sub>F</sub>                 | higher layer ConnectionLess channel (fast), (logical channel to the MAC layer)            |
| CLMS                            | ConnectionLess Message Service  |
| CLRR                            | Circuit Loudness Rating, Receiving  |
| CLRS                            | Circuit Loudness Rating, Sending  |
| CL <sub>S</sub>                 | higher layer ConnectionLess channel (slow), (logical channel to the MAC layer)            |
| CLSS                            | ConnectionLess Supplementary Service  |
| CMC                             | Connectionless Message Control  |
| C-MMS                           | Call control part of MMS  |
| CN                              | Carrier Number  |
| CODEC                           | COder-DECoder   |
| COMS                            | Connection Oriented Message Service   |
| C-plane                         | Control plane   |
| CRC                             | Cyclic Redundancy Check   |
| CRFP                            | Cordless Radio Fixed Part   |
| CRSS                            | Call Related Supplementary Services   |
| C <sub>S</sub>                  | higher layer signalling Channel (slow)  |
| CSF                             | Cell Site Function  |
| CSPDN                           | Circuit Switched Public Data Network  |
| CTA                             | Cordless Terminal Adapter   |
| CX                              | Co-eXistence standard   |
| DAM                             | DECT Authentication Module  |
| dBc                             | dB relative to the peak power of an unmodulated carrier                                   |
| DBC                             | Dummy Bearer Control  |
| dBm                             | dB relative to 1 milliwatt  |
| dBm0                            | the absolute power level in decibels referred to a point of zero relative level           |
| dB <sub>r</sub>                 | the relative power level in decibels  |
| DCDL-net                        | Distributed Communication DECT Local network  |

|       |  |
|-------|--|
| DCK   | Derived Cipher Key                           |
| DCS   | Dynamic Channel Selection                    |
| DECT  | Digital Enhanced Cordless Telecommunications |
| DefCK | Default Cipher Key                           |
| DES   | Data Encryption Standard                     |
| DLC   | Data Link Control                            |
| DLEI  | Data Link Endpoint Identifier (DLC layer)    |
| DLI   | Data Link Identifier (DLC layer)             |
| D-MAP | D-field MAP                                  |
| DNW   | DECT NetWork                                 |
| DPRS  | DECT Packet Radio Service                    |

NOTE: See EN 301 649 [11].

|          |   |
|----------|---|
| DSAA     | DECT Standard Authentication Algorithm  |
| DSC      | DECT Standard Cipher  |
| DTE      | Data Terminal Equipment   |
| DTMF     | Dual Tone Multi-Frequency   |
| E type   | B-field multiplexer mode when the slot carries signalling only (channels $C_F$ , $G_F$ and M)                         |
| E/U-mux  | B-field multiplexer (switching between E, U or E+U modes)   |
| E+U type | B-field multiplexer mode when the slot carries U-plane data (channel $I_{PF}$ ) AND signalling (channels $G_F$ and M) |
| ECN      | Exchanged Connection Number (DLC/MAC layer)   |
| EIRP     | Equivalent Isotropically Radiated Power   |
| ERP      | Ear Reference Point   |
| ERP      | Effective Radiated Power  |
| ES       | End System  |
| $FB_N$   | Frame Buffer (uNprotected)  |
| $FB_P$   | Frame Buffer (Protected)  |
| FEC      | Forward Error Correction  |
| FLEN     | Frame LENgth  |
| FMID     | Fixed part MAC IDentity   |
| F-MMS    | Fixed line-Multimedia Messaging Service   |
| FP       | DECT Fixed Part   |
| FREL     | Frame RELay service   |
| F-SMS    | Fixed line-Short Messaging Service  |
| FSWI     | Frame SWItching service   |
| FT       | Fixed radio Termination   |
| GAP      | Generic Access Profile  |
| GBN      | Go Back N   |
| $G_F$    | higher layer information control channel (a logical channel to the MAC layer)   |
| GFSK     | Gaussian Frequency Shift Keying   |
| GMSK     | Gaussian Minimum Shift Keying   |
| GNW      | Global NetWork  |
| GSM      | Global System for Mobile communications   |
| HDB      | Home Data Base  |
| HOV      | HandOVer flag   |
| HPP      | Headset PP  |
| HyP      | Hybrid Part   |
| I        | higher layer Information channel (see $I_N$ and $I_P$ ) in general  |
| IA5      | International Alphabet No. 5 as defined by ITU-T  |
| IFEI     | International Fixed Equipment Identity  |
| $I_N$    | higher layer Information channel (uNprotected), in general (logical channels to the MAC layer)                        |
| $I_{NA}$ | higher layer Information channel (unprotected), minimum delay operation   |
| $I_{NB}$ | higher layer Information channel (unprotected), normal delay operation  |
| $I_P$    | higher layer Information channel (Protected), in general (logical channels to the MAC layer)                          |
| IP       | Internet Protocol   |
| IPEI     | International Portable Equipment Identity   |



|                  |  |
|------------------|--|
| I <sub>PF</sub>  | higher layer Information channel (protected) transported multiplexed with signalling in the E+U type slots                           |
| I <sub>PM</sub>  | higher layer Information channel (protected) with multi subfield format  |
| I <sub>PMR</sub> | higher layer Information channel (protected) with multi subfield format, with error correction using MOD-2 retransmission mechanism  |
| I <sub>PQ</sub>  | higher layer Information channel (protected) with single subfield format   |
| I <sub>PQR</sub> | higher layer Information channel (protected) with single subfield format, with error correction using MOD-2 retransmission mechanism |
| IPUI             | International Portable User Identity   |
| IPv4             | Internet Protocol Version 4  |
| IPv6             | Internet Protocol Version 6  |
| I <sub>PX</sub>  | higher layer Information channel, encodec protected, minimum delay operation   |
| IRC              | Idle Receiver Control  |
| ISDN             | Integrated Services Digital Network  |
| ISM              | Industrial, Scientific and Medical   |
| IUT              | Implementation Under Test  |
| IV               | Initial Vector   |
| IWF              | InterWorking Functions   |
| IWU              | InterWorking Unit  |
| K                | authentication Key   |
| KS'              | FT authentication Session Key  |
| KS               | PT authentication Session Key  |
| KSG              | Key Stream Generator   |
| KSS              | Key Stream Segment   |
| LA               | Location Area  |
| LAL              | Location Area Level  |
| LAN              | Local Area Network   |
| LAPC             | a DLC layer C-plane protocol entity  |
| LAP-U            | Link Access Procedure (U-plane) (a service offered by LU3)   |
| Lb               | a DLC layer C-plane protocol entity  |
| LBN              | Logical Bearer Number  |
| Lc               | a DLC layer C-plane protocol entity  |
| LCE              | Link Control Entity  |
| LCN              | Logical Connection Number (DLC/MAC layer)  |
| LiA              | List Access  |
| LLe              | Local echo Loss  |
| LLME             | Lower Layer Management Entity  |
| LLN              | Logical Link Number (DLC layer)  |
| LNW              | Local NetWork  |
| LRMS             | Low Rate Messaging Service   |
| LRMS-PTM         | Low Rate Messaging Service, Point To Multi-point   |
| LRMS-PTP         | Low Rate Messaging Service, Point To Point   |
| LSB              | Least Significant Bit  |
| LSTR             | Listener SideTone Rating   |
| LT               | Lower Tester   |
| M                | MAC control channel in general (on A-tail or B fields)   |
| MAC              | Medium Access Control layer  |
| MAP              | bit MAPPings   |
| MBC              | Multi-Bearer Control   |
| MCEI             | MAC Connection Endpoint Identification   |
| MCI              | MAC Connection Identifier  |
| MCS              | Multi-Channel Set  |
| MDU              | Multiplexed Data Unit  |
| MM               | Mobility Management  |
| M-MMS            | Messaging part of MMS  |
| MMS              | Multimedia Messaging Service   |
| MMSP             | Multimedia Messaging Service Protocol  |
| MRP              | Mouth Reference Point  |
| MSB              | Most Significant Bit   |
| MSC              | Mobile Switching Centre  |

|                |   |
|----------------|---|
| M <sub>T</sub> | MAC control channel on A-tail field, or one message on such channel |
| MUX            | time MULTipleXor  |
| N              | identities channel  |
| NACK           | Negative ACKnowledgement  |
| NG-DECT        | New Generation DECT   |
| NLF            | New Link Flag   |
| NLP            | Non-Linear Processor  |
| NLR            | No Link Required  |
| NR             | Normal-Reverse  |
| NTP            | Normal Transmitted Power  |
| NWK            | NetWorK layer   |
| OLR            | Overall Loudness Rating   |
| OSI            | Open Systems Interconnection  |
| P              | Paging channel  |
| PA             | Portable Application  |
| PABX           | Private Automatic Branch eXchange                                   |
| PAP            | Public Access Profile   |
| PARI           | Primary Access Rights Identity                                      |
| PARK {y}       | PARK with value y for it is Park length indicator                   |
| PARK           | Portable Access Rights Key  |
| PAS            | Public Access Service   |
| PBX            | Private Branch eXchange   |
| PCI            | Protocol Control Information  |
| PCM            | Pulse Code Modulated  |
| PDU            | Protocol Data Unit  |
| PHL            | PHysical Layer  |
| PHS            | Portable HandSet  |
| PIN            | Personal Identity Number  |
| PLI            | Park Length Indicator   |
| PMID           | Portable part MAC IDentity (MAC layer)                              |
| POT(S)         | Plain Old Telephone (Service)                                       |
| PP             | DECT Portable Part  |
| ppm            | parts per million   |
| PSCN           | Primary Scan Carrier Number   |
| PSPDN          | Packet Switched Public Data Network                                 |
| PSTN           | Public Switched Telephone Network                                   |
| PT             | Portable radio Termination  |
| PTN            | Private Telecommunication Network                                   |
| PUN            | Portable User Number  |
| PUT            | Portable User Type  |
| PWT            | Personal Wireless Telecommunications                                |
| Q              | system information channel  |
| QDU            | Quantization Distortion Unit  |
| RAND-F         | a RANDom challenge issued by a FT                                   |
| RAND-P         | a RANDom challenge issued by a PT                                   |
| ReFP           | Reference Fixed Part  |
| REP            | REpeater Part   |
| RePP           | Reference Portable Part   |
| RES1           | a RESponse calculated by a PT                                       |
| RES2           | a RESponse calculated by an FT                                      |
| RF             | Radio Frequency   |
| RFP            | Radio Fixed Part  |
| RFPI           | Radio Fixed Part Identity   |
| RLL            | Radio in the Local Loop   |
| RLRH           | Receiving Loudness Rating of the Handset                            |
| RPN            | Radio fixed Part Number   |
| RS             | a value used to establish authentication session keys               |
| RSSI           | Radio Signal Strength Indicator                                     |
| RU             | Residential Unit  |
| SAP            | Service Access Point  |
| SAPI           | Service Access Point Identifier                                     |

|                  |   |
|------------------|---|
| SAR              | Specific Absorption Rate  |
| SARI             | Secondary Access Rights Identity  |
| SCK              | Static Cipher Key   |
| SDU              | Service Data Unit   |
| SEL              | SElective   |
| SIM              | Subscriber Interface Module   |
| SI <sub>N</sub>  | higher layer connectionless channel (Unprotected)   |
| SI <sub>P</sub>  | higher layer connectionless channel (Protected)   |
| SI <sub>PF</sub> | higher layer connectionless channel (protected) transported multiplexed with signalling in the E+U type slots |
| SLRH             | Sending Loudness Rating of the Handset  |
| SMS              | Short Message Service   |
| SN               | Slot Number   |
| SP               | Start Position  |
| SPR              | Spare Bits  |
| SRAT             | Secondary Rate AdapTion service   |
| SRFP             | Single Radio Fixed Part   |
| SS               | Supplementary Services  |
| STMR             | SideTone Masking Rating   |
| TAF              | Terminal Adaptation Function  |
| TARI             | Tertiary Access Rights Identity   |
| TBC              | Traffic Bearer Control  |
| TCL              | Telephone Coupling Loss   |
| TCL <sub>w</sub> | weighted Terminal Coupling Loss   |
| TDD              | Time Division Duplex  |
| TDM              | Time Division Multiplex   |
| TDMA             | Time Division Multiple Access   |
| TELR             | Talker's Echo Loudness Rating   |
| TI               | Transaction Identifier  |
| T-MUX            | Tail MUX  |
| TPUI             | Temporary Portable User Identity  |
| TRUP             | TRansparent UnProtected service   |
| U type           | B-field multiplexer mode when the slot carries U-plane data only (channels I <sub>N</sub> or I <sub>P</sub> ) |
| UAK              | User Authentication Key   |
| UCN              | U-plane Channel Number  |
| ULI              | Unassigned Link Identifier  |
| ULN              | U-plane Link Number   |
| UMTS             | Universal Mobile Telecommunication System   |
| UPCS             | Unlicensed Personal Communications Service  |
| UPI              | User Personal Identification  |
| U-plane          | User plane  |
| VDB              | Visitors Data Base  |
| W-FT2FT          | Wireless FT to FT communication   |
| WRS              | Wireless Relay Station  |
| XRES1            | an eXpected RESponse calculated by a FT   |
| XRES2            | an eXpected RESponse calculated by a PT   |

---

## 4 Structure

The present multi-part deliverable consists of 8 parts (parts 1 to 8 [8] inclusive) which are briefly described in clauses 4.1 to 4.8.

EN 300 175-2 [2] to EN 300 175-5 [5] of specify the air interface. They are structured into layers corresponding to the lower layers of the ISO OSI model. EN 300 175-6 [6] specifies the identities and addressing structure and EN 300 175-7 [7] specifies the security features. EN 300 175-8 [8] specifies speech aspects.

In addition there exists a DECT approval test specification EN 300 176 [9] which is not described in the present document.

## 4.1 Part 1: Overview

The overview (the present document) contains an introduction to the complete European Standard. It includes a description of the system and the protocol architecture and a vocabulary of terms.

## 4.2 Part 2: Physical Layer (PHL)

The PHL (EN 300 175-2 [2]) specifies radio parameters such as the frequency, timing and power values, the bit and slot synchronization and the transmitter and receiver performance. This specification defines a basic 2-level modulation mode (GFSK) plus optional high level modulation modes up to 64 QAM, providing higher capacities.

## 4.3 Part 3: Medium Access Control (MAC) layer

The MAC layer (EN 300 175-3 [3]) specifies three groups of MAC services. These are the broadcast message control service, the connectionless message control service and the multi-bearer control service. It also specifies the logical channels, which are used by the above-mentioned services, and how they are multiplexed and mapped on to the physical channels.

## 4.4 Part 4: Data Link Control (DLC) layer

The DLC layer (EN 300 175-4 [4]) specifies two groups of DLC services. These are the services for the C-plane and the services for the U-plane.

For the C-plane a point-to-point service and a broadcast service are defined. The point-to-point service can operate in acknowledged or unacknowledged mode and provides addressing, frame delimiting, error control, flow control, segmentation of network layer information fields, fragmentation of DLC frames and connection handover.

For the U-plane the transparent unprotected service, the frame relay service, the frame switching service and the rate adoption service are defined.

## 4.5 Part 5: Network (NWK) layer

The NWK layer (EN 300 175-5 [5]) specifies the functions for the link control, the Call Control (CC), the Supplementary Services (SS), the Connection Oriented Message Service (COMS), the ConnectionLess Message Service (CLMS) and the Mobility Management (MM). For these groups it contains the procedures, messages and information elements.

## 4.6 Part 6: Identities and addressing

The identities and addressing (EN 300 175-6 [6]) specifies the main identities and addresses which are used in DECT. They are divided into the following four categories: FP identities, PP identities, connection related identities and equipment related identities.

Several of the FP identities and PP identities are allocated centrally in order to maintain global uniqueness for these identities.

## 4.7 Part 7: Security features

The security features (EN 300 175-7 [7]) specify the overall security architecture for DECT, the types of cryptographic algorithms required and the way in which they are to be used, and the requirements for integrating the security features provided by the architecture into the DECT air interface. It also describes how the features may be managed and how they relate to certain DECT fixed systems and local network configurations.

## 4.8 Part 8: Speech and audio coding and transmission

The speech and audio coding and transmission (EN 300 175-8 [8]) specifies the requirements for DECT equipment which includes all the necessary functions to provide real-time two-way speech conversation or other audio services. It defines the different speech and audio encoding algorithms supported by DECT and the detailed audio performance characteristics of DECT PPs and FPs such as sensitivity, frequency response, sidetone, terminal coupling loss, distortion, variation of gain with input level, out of band signals, noise, acoustic shock, delay and network echo control.

---

## 5 The objectives of the CI standard

The DECT standard has grown out of the need to provide cordless communications, both for voice traffic and for data traffic.

The DECT standard is designed to support this versatility of applications at a cost that encourages wide adoption. DECT provides personal telecommunication services in residential, neighbourhood and business environments. It is particularly targeted at the following applications:

- residential - domestic cordless telephones (PSTN, ISDN and IP access);
- public access services;
- cordless business telephones (PBXs and converged IP based business networks);
- cordless data - Local Area Networks (LANs) and point-to-point connections;
- wireless home networking;
- wireless access to the internet or intranet;
- machine to machine or machine to man (m2m) wireless communication (e.g. sensors, alarms, monitoring and metering devices);
- extensions to cellular radio and extensions of the local public network;
- Radio in the Local Loop (RLL).

The DECT standard supports narrowband (3,1 kHz) telephony as well as wideband (7 kHz) and superwideband (up to 14 kHz) audio transmission with a range of audio codecs and acoustic models as defined in EN 300 175-8 [8].

The DECT standard supports circuit mode and packed mode data transmission with a maximum data rate of 844,8 kbit/s for 2 level modulation , single transceiver systems and 5,0688 Mbit/s for systems implementing high level modulation (single transceiver). These rates could be multiplied using multiple radio channels in parallel. Refer to EN 301 649 [11] for description of packet data capabilities in DECT.

DECT has also been selected by the ITU as one of the radio interfaces for "International Mobile Telecommunications 2000" (IMT-2000) [10]. As DECT is using a combination of frequency and time multiple access the corresponding air-interface is called "IMT-2000 FDMA/TDMA" by the ITU.

Because of different regulatory requirements in the USA, the American National Standards Institute (ANSI) has published (1997) a derivative of the DECT standard as the PWT standard, implementing the required adaptations, especially in the physical layer. However, during 2004 the requirements in the USA were modified, whereby standard DECT equipment may be used with minor modifications in the channel allocation procedures and in RF power setting. (See new TR describing modifications differences in DECT standard to meet new UPCS rules.) This will make the PWT standard obsolete. Other requirements relevant for utilization of DECT in USA, e.g. in the UPCS 1 920 MHz to 1 930 MHz and IMS 2,4 GHz are specified in various ETSI DECT standards.

One primary objective of this CI standard is to provide a basis for interoperability between equipment of different origin, so offering users a family of telecommunication services for voice or data, either as basic services, or with optional (and compatible) extensions.

While providing for compatibility, the present document provides standard escape routes that allow manufacturers to retain options for innovation and product differentiation (see clause 8). In addition, reserved codes have been included in the present document to provide mechanisms for evolutionary development of the present document. At the same time, the existence of the present document allows implementers to design systems that can provide telecommunications to users in several different locations.

At a more detailed level, the protocols in the present document are designed to provide for the specific services and facilities defined in ETR 043 [i.5] and ITU-R Recommendation M.816-1 [i.3]. In the design process, the following additional objectives were considered:

- the structure should allow any other reasonable application;
- the structure should allow any reasonable implementation.

Lastly, the present document also has the objective of regulating the use of, and interface of, two shared resources:

- the RF spectrum which is allocated to provide for the cordless operation of the communication system; and
- one or more networks for which the DECT network provides cordless connection.

It is the objective of the present standard to ensure that conforming equipment will be able to use the above resources efficiently and with the minimum degree of mutual interference, i.e. avoiding adverse affects to existing, or future, users of those resources, see also ITU-R Recommendation SM.1046-2 [i.2].

## 6 General description of the system

DECT is based on a micro-cellular radio communication system that provides low-power radio (cordless) access between PPs and (DECT) FPs at ranges up to a few hundred metres (up to several kms for fixed access systems). The basic technical characteristics are as follows:

|                              |  |
|------------------------------|--|
| frequency band:              | 1 880 MHz to 1 980 MHz and 2 010 MHz to 2 025 MHz (see note 1);  |
| number of carriers:          | typical 10 (see note 1);   |
| carrier spacing:             | 1,728 MHz (see note 1);  |
| maximum peak transmit power: | 250 mW (see note 1);   |
| carrier multiplex:           | TDMA; 12 double slots/24 full slots/48 half slots per frame;   |
| frame length:                | 10 ms;   |
| basic duplexing:             | TDD using 2 slots on same RF carrier;  |
| gross bit rate:              | 1 152 kbit/s, 2 304 kbit/s, 3 456 kbit/s, 4 608 kbit/s or 6 912 kbit/s for 2-, 4-, 8-, 16- or 64-level modulation respectively (see note 2); |
| net channel rates:           | 6,4 kbit/s A-field (control/signalling) per slot.  |

B-field (traffic) rates per slot are described in table 1.

**Table 1**

| Type of modulation  | Maximum B-field (traffic) rate per slot |                     |                     |            |             | Maximum asymmetric B-field (traffic) data rate (11 double slots) |
|---------------------|---|---------------------|---------------------|------------|-------------|--|
|                     | half slot (j = 80)                      | long slot (j = 640) | long slot (j = 672) | full slot  | double slot |  |
| 2-level modulation  | 8 kbit/s                                | 64 kbit/s           | 67,2 kbit/s         | 32 kbit/s  | 80 kbit/s   | 880 kbit/s   |
| 4-level modulation  | 16 kbit/s                               | 128 kbit/s          | 134,4 kbit/s        | 64 kbit/s  | 160 kbit/s  | 1 760 kbit/s   |
| 8-level modulation  | 24 kbit/s                               | 192 kbit/s          | 201,6 kbit/s        | 96 kbit/s  | 240 kbit/s  | 2 640 kbit/s   |
| 16-level modulation | 32 kbit/s                               | 256 kbit/s          | 268,8 kbit/s        | 128 kbit/s | 320 kbit/s  | 3 520 kbit/s   |
| 64-level modulation | 48 kbit/s                               | 384 kbit/s          | 403,2 kbit/s        | 192 kbit/s | 480 kbit/s  | 5 280 kbit/s   |

NOTE 1: The complete definition of frequency bands and carrier positions for DECT are found in EN 300 175-2 [2]. DECT is a member of the IMT-2000 family [10], the only member that provides for uncoordinated installations on an unlicensed spectrum. The most common spectrum allocation is 1 880 MHz to 1 900 MHz, but outside Europe spectrum is also available in 1 900 MHz to 1 920 MHz and in 1 910 MHz to 1 930 MHz (several countries). Carrier positions in the 902 MHz to 928 MHz and 2 400 MHz to 2 483,5 MHz ISM bands have been defined for the US market. New or modified carrier positions and/or frequency bands can be defined when needed. The number of carriers depends on the frequency spectrum in use and the carrier spacing. Maximum peak transmit power also depends on local regulations or environment requirements.

NOTE 2: Depending on radio capabilities or number of radios used a DECT system can provide higher data rate. The indicated here values are relevant for radios operating on 10 carriers and non overlapping slots.

A connection is provided by transmitting bursts of data in the defined time slots. These may be used to provide simplex or duplex communications. Duplex operation uses one or several pairs of evenly (5 ms) spaced slots. Of the paired slots one is for transmit and one for receive.

The simplest duplex service uses a single pair of time slots to provide e.g. a 32 kbit/s (2-level modulation) digital information channel capable of carrying coded speech or other low rate digital data. Higher data rates are achieved by using more time slots in the TDMA structure, and a lower data rate may be achieved by using half-slot data bursts. Different uplink and downlink bitrates are realized by using asymmetric connections, where a different number of time slots is used for the uplink and downlink. For efficient transmission of packet data the radio connection can be suspended after the data has been sent and as soon as new data arrives, the radio connection is resumed again.

DECT is able to support a number of alternative system configurations ranging from single cell equipment (e.g. domestic FPs) to large multiple cell installations (e.g. large business cordless PBXs or converged IP based business systems), public pedestrian systems and fixed wireless access (radio local loop) systems.

The protocols are designed to support uncoordinated system installation, even where the systems co-exist in the same physical location. Efficient sharing of the radio spectrum (of the physical channels) is achieved using a careful mechanism for selection of channels prior to their use. This is called dynamic channel selection (see ETR 310 [i.7]).

In addition, the DECT protocols provide two internal mechanisms to support rapid handover of calls in progress (both intracell and intercell handover are supported). These handover mechanisms allows a high quality of service to be maintained where the mobility of the PP requires transparent re-connection to another FP or where a new physical channel is required in response to a disturbances in the radio environment.

Wireless Relay Stations (WRSs) for wireless coverage enhancements, direct communication from PT to PT and wireless communication between FTs is also supported.

DECT is an access technology providing sufficient flexibility for access to various communication networks, e.g. IP, PSTN, ISDN, LAN, GSM, UMTS, etc.

---

## 7 Description of the protocol architecture

### 7.1 General

The structure of the present document is based on the layered principles used in the ISO Open Systems Interconnection (OSI) model. The complete CI corresponds to the lower 3 layers of the ISO OSI model. In order to take care of the uncertainties introduced by using radio transmissions at the PHL and to include the concept of handover, the layer 2 has been split into two sub-layers. Therefore DECT defines 4 layers of protocol.

### 7.2 The DECT layered structure

A structure of four layers is used for the signalling protocols as shown in figure 1.

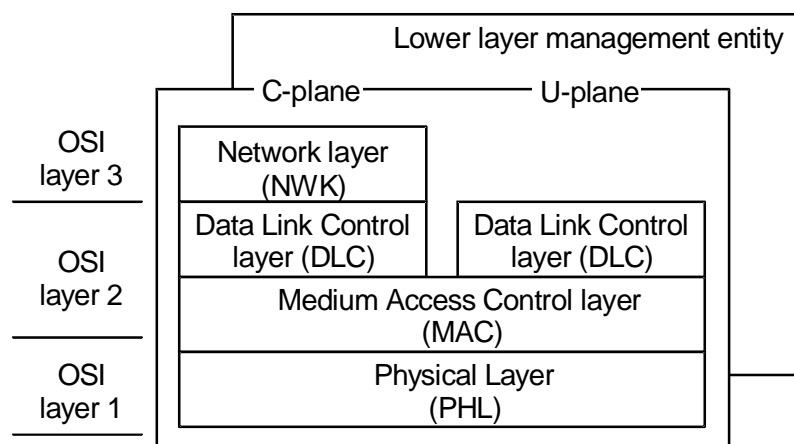

**Figure 1: The layered structure**

The top of the NWK layer corresponds to the top of the OSI layer 3. The intermediate boundaries have no OSI equivalent but for ease of understanding an approximate correspondence is given below:

- OSI Layer 1: all of the PHL plus part of MAC layer;
- OSI Layer 2: most of MAC layer plus all of DLC;
- OSI Layer 3: all of the NWK layer.

## 7.3 Physical Layer (PHL)

The PHL (EN 300 175-2 [2]) divides the radio spectrum into the physical channels. This division occurs in two fixed dimensions, frequency and time.

The frequency and time division uses Time Division Multiple Access (TDMA) operation on multiple RF carriers. Typically ten carriers are provided within the actual frequency band (1 880 MHz to 1 900 MHz is the most common frequency allocation for DECT). The present document also provides for possible extensions of the band to meet future demand. On each carrier the TDMA structure defines 24 full-slots in a 10 ms frame, where each timeslot may be used to transmit one self contained packet of data. Each transmitted packet contains a synchronization field, together with control information, service information and error control.

**NOTE:** In addition the radio spectrum is divided spatially into cells, where the same physical channels may be re-used in different (geographic) locations. The spatial re-use operates according to the principles of Dynamic Channel Selection (DCS) as described in ETR 310 [i.7] dealing with DECT features.

Each radio end point operates according to a timing reference and the PHL is then responsible for transmitting packets of data under direct control of the MAC layer. Adjacent FPs may be synchronized. This provides some advantages, particularly in high traffic situations (see ETR 310 [i.7]).

## 7.4 MAC layer

The MAC layer (EN 300 175-3 [3]) performs two main functions. Firstly, it selects physical channels, and then establishes and releases connections on those channels. Secondly, it multiplexes (and demultiplexes) control information, together with higher layer information and error control information, into slot-sized packets.

These functions are used to provide three independent services; a broadcast service, a connection oriented service and a connectionless service.



The broadcast service is a special DECT feature: it multiplexes a range of broadcast information into a reserved field (the A-field), and this field appears as part of all active transmissions. The broadcast service is always transmitted in every cell (even in the absence of user traffic) on at least one physical channel. These "beacon" transmissions allow PPs to quickly identify all FPs that are within range, to select one, and to lock to it without requiring any portable transmissions.

## 7.5 DLC layer

The DLC layer (EN 300 175-4 [4]) is concerned with the provision of very reliable data links to the NWK layer. Many of the imperfections of the radio transmissions are already removed by the efforts of the MAC layer, and the DLC layer is designed to work closely with the MAC layer to provide higher levels of data integrity than can be provided by the MAC layer alone.

The DECT layered model separates into two planes of operation at the DLC layer; the C-plane and the U-plane.

The C-plane is common to all applications, and provides very reliable links for the transmission of internal control signalling and limited quantities of user information traffic. Full error control is provided with a balanced Link Access Protocol (LAPC).

The U-plane provides a family of alternative services, where each service is optimized to the particular need of a specific type of services. The simplest service is the transparent unprotected service used for speech transmission. Other services support circuit mode and packet mode data transmission, with varying levels of protection.

## 7.6 Network (NWK) layer

The NWK (EN 300 175-5 [5]) layer is the main signalling layer of the protocol. It adopts a similar style to the ISDN layer 3 protocol (see EN 300 403-1 [i.1]) and offers a similar level of functions.

The NWK layer operates using an exchange of messages between peer entities. The basic set of messages supports the establishment, maintenance and release of calls. Additional messages support a range of extended capabilities.

The basic CC provides a circuit switched service selected from one of the range of DLC options. Other network layer services are SS, COMS, CLMS and MM. These services are arranged as independent entities, and a particular application can be realized using more than one.

The MM is a particularly important group of services. This group contains the procedures that support the special cordless mobility of PPs, for example authentication and location registration.

## 7.7 Lower Layer Management Entity (LLME)

The LLME contains defined procedures that concern more than one layer. The LLME procedures are included in EN 300 175-3 [3] to EN 300 175-5 [5]. Most of these procedures have only local significance, and they are defined in general terms to allow for alternative implementations. The location of some selected LLME procedures is as follows:

MAC layer:

- creation, maintenance and release of bearers, by activating and deactivating pairs of physical channels;
- physical channel management, including the choice of free physical channels and the assessment of the quality of received signals;
- switching between PT and FT mode when direct PT to PT or wireless FT to FT communication is provided.

DLC layer:

- connection management, which includes the establishment and release of connections in response to NWK layer demands;
- routing of C-plane and U-plane data to suitable connections.

NWK layer:

- service negotiation and mapping;
- application parameters (e.g. addresses) and DECT identities resolution.

## 7.8 Interworking Units (IWU)

Transport of the information to the end user requires additional layers of protocol that are outside the scope of the present document. In general, an IWU will be required to provide the necessary interworking functions. This IWU plays an important role in defining the exact service that is provided. Specifications of IWUs defining the interworking between the DECT air interface and various networks and line interfaces can be found in additional DECT profile specifications. A brief overview can be found in TR 101 178 [i.4].

# 8 Proprietary escapes within the CI

A set of defined escape routes has been provided for implementers that wish to implement proprietary additions or alternatives to the CI protocol, as shown in figure 2.

## 8.1 Primary escape routes

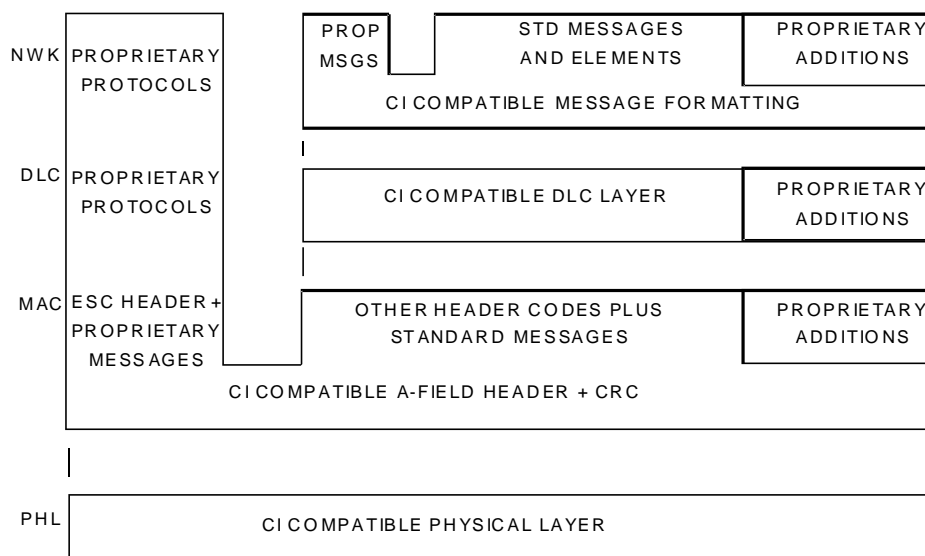

**Figure 2: Structure of escape routes within the CI**

Two primary escape routes are defined within the CI standard, one at the MAC layer and one at the NWK layer. In both cases these escape routes provide the possibility for manufacturers to branch into a family of proprietary protocols. These branches provide a compatible method for proprietary systems to operate without causing confusion or interference to systems that implement the other CI provisions.

The lowest branch occurs at the MAC layer. The branch is defined at this level in order to ensure a minimum level of conformance to the CI. The minimum level of conformance therefore includes all of the PHL and the lower parts of the MAC layer (in particular, the MAC A-field header, A-field CRC and the channel selection procedures).

This MAC branch operates by using one reserved code in the MAC header field (the field that appears at the start of every transmission, see EN 300 175-3 [3]). All equipment shall understand this reserved code. This reserved code shall be used in every transmission from proprietary equipment and shall never be used by equipment that conforms to the standard branch. This means that transmissions from proprietary systems can be immediately identified by all other equipment.

For approvals testing purposes a small number of standard messages shall be supported by proprietary equipment when operating in a special test mode. No messages are mandated for proprietary equipment in normal operating mode.

At the NWK layer the escape route operates by using a reserved protocol discriminator code. All equipment shall understand this code, it shall be used exclusively by proprietary protocols (other codes are reserved for the standard protocols) to clearly indicate that a proprietary protocol is in use. In this case proprietary protocols can co-exist with standard protocols as part of the same equipment.

## 8.2 Secondary escape routes

In addition to these primary escape routes, a series of secondary escape routes are defined at all layers using reserved codes or optional elements, as appropriate. These small branches allow proprietary information to be included in addition to the CI information. They are designed to allow manufactures to enhance the CI with proprietary features without compromising the basic level of interoperability.

---

# 9 Levels of conformance

The following levels of CI conformance are defined:

- CI-PROFILE-PLUS: ETSI approved CI operating profile(s) with proprietary extensions;
- CI-PROFILE: ETSI approved CI operating profile(s) (e.g. GAP);
- CI-BASE: PHL and minimum MAC conformance.

The CI-Base defines the minimum level of conformance to the CI standard. It does not imply any speech transmission characteristics.

---

## Annex A (informative): Bibliography

- IETF RFC 0791: "Internet protocol".
- IETF RFC 2460: "Internet Protocol, Version 6 (IPv6) Specification".
- ITU-T Recommendation R.140 (1988): "Definitions of essential technical terms in the field of telegraph transmission", definition 6014.
- ITU-T Recommendation X.25: "Interface between Data Terminal Equipment (DTE) and Data Circuit-terminating Equipment (DCE) for terminals operating in the packet mode and connected to public data networks by dedicated circuit".

## Annex B (informative): Change history

The following table presents main changes from a published version to the next version (published or to be published).

| <b>Subject/Comment</b>  | <b>Old</b> | <b>New</b> |
|---|------------|------------|
| The enhancement of the DECT base standard to support higher data rates includes the 16 QAM/64 QAM modulation option and the Channel Coding based on the Turbo Code Principle.     | 1.6.1      | 1.7.1      |
| The enhancement of the DECT base standard to support DECT Broadband service and backwards compatible changes for support of DECT access to IP networks (TS 102 265 V1.1.1 [i.8]). | 1.7.1      | 1.8.1      |
| Editorial update, UPCS information added  | 1.8.1      | 1.9.1      |
| New Generation DECT: A major revision of the DECT base standard introducing wideband speech, improved data services, new slot types and other technical enhancements.             | 1.9.1      | 2.1.1      |
| Update of symbols and abbreviations list. Editorial review.   | 2.1.1      | 2.2.1      |
| Update of definitions, symbols and abbreviations lists.   | 2.2.1      | 2.3.1      |

## History

| <b>Document history</b> |                |   |
|-------------------------|----------------|---|
| Edition 1               | October 1992   | Publication as ETS 300 175-1 (Historical)                               |
| Edition 2               | September 1996 | Publication as ETS 300 175-1 (Historical)                               |
| V1.4.2                  | June 1999      | Publication   |
| V1.5.1                  | February 2001  | Publication   |
| V1.6.1                  | January 2002   | Publication   |
| V1.7.1                  | July 2003      | Publication   |
| V1.8.1                  | November 2004  | Publication   |
| V1.9.1                  | September 2005 | Publication   |
| V2.1.1                  | August 2007    | Publication   |
| V2.2.1                  | November 2008  | Publication   |
| V2.3.0                  | February 2010  | One-step Approval Procedure      OAP 20100605: 2010-02-05 to 2010-06-07 |