

Draft **EN 300 175-1** V1.4.1 (1998-02)

---

*European Standard (Telecommunications series)*

**Digital Enhanced Cordless Telecommunications (DECT);  
Common Interface (CI);  
Part 1: Overview**

---



*European Telecommunications Standards Institute*

---

---

Reference

REN/DECT-000129-1 (1mc90jco.PDF)

---

Keywords

DECT, radio

***ETSI Secretariat***

---

Postal address

F-06921 Sophia Antipolis Cedex - FRANCE

---

Office address

650 Route des Lucioles - Sophia Antipolis  
Valbonne - FRANCE  
Tel.: +33 4 92 94 42 00 Fax: +33 4 93 65 47 16  
Siret N° 348 623 562 00017 - NAF 742 C  
Association à but non lucratif enregistrée à la  
Sous-Préfecture de Grasse (06) N° 7803/88

---

X.400

c= fr; a=atlas; p=etsi; s=secretariat

---

Internet

secretariat@etsi.fr  
<http://www.etsi.fr>

---

***Copyright Notification***

No part may be reproduced except as authorized by written permission.  
The copyright and the foregoing restriction extend to reproduction in all media.

---

# Contents

Intellectual Property Rights.....	4
Foreword .....	5
1 Scope.....	6
2 References.....	6
2.1 Normative references.....	6
2.2 Informative references .....	7
3 Definitions and abbreviations .....	7
3.1 Definitions .....	7
3.2 Abbreviations.....	14
4 Structure .....	16
4.1 Part 1: Overview .....	16
4.2 Part 2: Physical Layer (PHL).....	16
4.3 Part 3: Medium Access Control (MAC) layer.....	16
4.4 Part 4: Data Link Control (DLC) layer .....	17
4.5 Part 5: Network (NWK) layer.....	17
4.6 Part 6: Identities and addressing .....	17
4.7 Part 7: Security features .....	17
4.8 Part 8: Speech coding and transmission.....	17
5 The objectives of the CI standard .....	18
6 General description of the system.....	19
7 Description of the protocol architecture .....	20
7.1 General.....	20
7.2 The DECT layered structure .....	20
7.3 Physical Layer (PHL) .....	20
7.4 MAC layer .....	21
7.5 DLC layer .....	21
7.6 Network (NWK) layer .....	21
7.7 Lower Layer Management Entity (LLME) .....	22
7.8 Interworking Units (IWU) .....	22
8 Proprietary escapes within the CI .....	22
8.1 Primary escape routes .....	22
8.2 Secondary escape routes .....	23
9 Levels of conformance.....	23
History .....	24

---

## Intellectual Property Rights

IPRs essential or potentially essential to the present document may have been declared to ETSI. The information pertaining to these essential IPRs, if any, is publicly available for **ETSI members and non-members**, and can be found in ETR 314: "*Intellectual Property Rights (IPRs); Essential, or potentially Essential, IPRs notified to ETSI in respect of ETSI standards*", which is available **free of charge** from the ETSI Secretariat. Latest updates are available on the ETSI Web server (<http://www.etsi.fr/ipr>).

Pursuant to the ETSI Interim IPR Policy, no investigation, including IPR searches, has been carried out by ETSI. No guarantee can be given as to the existence of other IPRs not referenced in ETR 314 (or the updates on <http://www.etsi.fr/ipr>) which are, or may be, or may become, essential to the present document.

## Foreword

This European Standard (Telecommunications series) has been produced by ETSI Project Digital Enhanced Cordless Telecommunications (DECT), and is now submitted for the Public Enquiry phase of the ETSI standards Two-step Approval Procedure.

The present document forms part 1 of a series of 9-8 laying down the arrangements for the Digital Enhanced Cordless Telecommunications (DECT) Common Interface (CI), and provides an overview of the whole EN.

**Part 1: "Overview";**

Part 2 "Physical Layer (PHL)";

Part 3 "Medium Access Control (MAC) layer";

Part 4 "Data Link Control (DLC) layer";

Part 5: "Network (NWK) layer";

Part 6: "Identities and addressing";

Part 7: "Security features";

Part 8: "Speech coding and transmission".

~~Part 9: "Public Access Profile (PAP)".~~

The following aspects of the present document are subject to controlled distribution:

- a) DECT identities, as defined in EN 300 175-6 [5];
- b) DECT cryptographic algorithms.

The cryptographic algorithms specify the details of the DECT standard authentication algorithm and the DECT standard cipher.

These aspects are distributed on an individual basis. Further information and details of the current distribution procedures can be obtained from the ETSI Secretariat at the address on the first page of the present document.

Further details of the DECT system may be found in ETR 015 [10], ETR 043 [12], and ETR 056 [13].

This version of the CI standard has been converted to an EN, in line with parts 2 - 8 of the standard. ETS 300 175-9 has not been converted, as it is no longer maintained by the DECT Project.

Changes from the second edition of ETS 300 175-1 are shown with revision marks, which may be removed after adoption of the present document. Formatting changes due to the conversion to EN are not shown.

<b>Proposed national transposition dates</b>	
Date of latest announcement of this EN (doa):	3 months after ETSI publication
Date of latest publication of new National Standard or endorsement of this EN (dop/e):	6 months after doa
Date of withdrawal of any conflicting National Standard (dow):	6 months after doa

---

# 1 Scope

This standard gives an introduction and overview of the complete Digital Enhanced Cordless Telecommunications (DECT) Common Interface (CI).

This part of the DECT CI contains an abstract of the other parts of the DECT standard together with a general description of:

- the objectives of the the present document;
- the DECT CI;
- the protocol architecture of DECT.

This part also provides an extensive vocabulary, in particular it contains the common definitions of all the technical terms used in different parts of the present document.

---

# 2 References

References may be made to:

- a) specific versions of publications (identified by date of publication, edition number, version number, etc.), in which case, subsequent revisions to the referenced document do not apply; or
- b) all versions up to and including the identified version (identified by "up to and including" before the version identity); or
- c) all versions subsequent to and including the identified version (identified by "onwards" following the version identity); or
- d) publications without mention of a specific version, in which case the latest version applies.

A non-specific reference to an ETS shall also be taken to refer to later versions published as an EN with the same number.

## 2.1 Normative references

- [1] EN 300 175-2: "Digital Enhanced Cordless Telecommunications (DECT); Common Interface (CI); Part 2: Physical Layer (PHL)".
- [2] EN 300 175-3: "Digital Enhanced Cordless Telecommunications (DECT); Common Interface (CI); Part 3: Medium Access Control (MAC) layer".
- [3] EN 300 175-4: "Digital Enhanced Cordless Telecommunications (DECT); Common Interface (CI); Part 4: Data Link Control (DLC) layer".
- [4] EN 300 175-5: "Digital Enhanced Cordless Telecommunications (DECT); Common Interface (CI); Part 5: Network (NWK) layer".
- [5] EN 300 175-6: "Digital Enhanced Cordless Telecommunications (DECT); Common Interface (CI); Part 6: Identities and addressing".
- [6] EN 300 175-7: "Digital Enhanced Cordless Telecommunications (DECT); Common Interface (CI); Part 7: Security features".
- [7] EN 300 175-8: "Digital Enhanced Cordless Telecommunications (DECT); Common Interface (CI); Part 8: Speech coding and transmission".
- [8] ~~ETS 300 175 9 (1996): "Radio Equipment and Systems (RES); Digital Enhanced Cordless Telecommunications (DECT); Common Interface (CI); Part 9: Public Access Profile (PAP)".~~

- [9] EN 300 176: "Digital Enhanced Cordless Telecommunications (DECT); Approval test specification".

## 2.2 Informative references

- [10] ETR 015: "Digital Enhanced Cordless Telecommunications (DECT); Reference document".
- [11] ETR 042: "Digital Enhanced Cordless Telecommunications (DECT); A Guide to DECT features that influence the traffic capacity and the maintenance of high radio link transmission quality, including the results of simulations".
- [12] ETR 043: "Digital Enhanced Cordless Telecommunications (DECT); Common interface; Services and facilities requirements specification".
- [13] ETR 056: "Digital Enhanced Cordless Telecommunications (DECT); System description document".
- [14] EN 300 403: "Integrated Services Digital Network (ISDN); Digital Subscriber Signalling System No. one (DSS1) protocol; Signalling network layer for circuit-mode basic call control".
- [15] CEPT Recommendation T/SGT SF2 (89) 6/0: "Draft Recommendation T/SF Services and Facilities of Digital European Cordless Telecommunications".
- [16] CCIR Report 662 (1978): "Definition of spectrum use and efficiency".

---

## 3 Definitions and abbreviations

### 3.1 Definitions

For the purposes of the present document, the following definitions apply:

**antenna diversity:** Diversity implies that the Radio Fixed Part (RFP) for each bearer independently can select different antenna properties such as gain, polarization, coverage patterns, and other features that may effect the practical coverage. A typical example is space diversity, provided by two vertically polarized antennas separated by 10 - 20 cm.

**attach:** The process whereby a Portable Part (PP) within the coverage area of a Fixed Part (FP) to which it has access rights, notifies the FP that it is operative. The reverse process is detach, which reports the PP as inoperative.

NOTE 1: An operative PP is assumed to be ready to receive calls.

**authentication (of a subscriber):** The process whereby a DECT subscriber is positively verified to be a legitimate user of a particular FP.

NOTE 2: Authentication is generally performed at call set-up, but may also be done at any other time (e.g. during a call).

**bearer:** See Medium Access Control (MAC) bearer or bearer service.

**bearer handover:** The internal handover process provided by the MAC layer, whereby one MAC connection can modify its underlying bearers while maintaining the service provided to the Data Link Control (DLC) layer.

NOTE 3: Bearer handover is slot based.

**bearer service:** A type of telecommunication service that provides a defined capability for the transmission of signals between user-network interfaces.

NOTE 4: The DECT user-network interface corresponds to the top of the DECT network layer (layer 3).

**broadcast:** A simplex point-to-multipoint mode of transmission.

NOTE 5: The transmitter may disregard the presence or absence of receivers.

**C-plane:** The control plane of the DECT protocol stacks, which contains all of the internal DECT protocol control, but may also include some external user information.

NOTE 6: The C-plane stack always contains protocol entities up to and including the network layer.

**call:** All of the Network (NWK) layer processes involved in one NWK layer peer-to-peer association.

NOTE 7: Call may sometimes be used to refer to processes of all layers, since lower layer processes are implicitly required.

**cell:** The domain served by a single antenna(e) system (including a leaky feeder) of one FP.

NOTE 8: A cell may include more than one source of radiated Radio Frequency (RF) energy (i.e. more than one radio end point).

**Central Control Fixed Part (CCFP):** A physical grouping that contains the central elements of a FP. A FP contains a maximum of one CCFP.

NOTE 9: A CCFP controls one or more RFPs.

**centrex:** An implementation of a private telecommunication network exchange that is not located on the premises of the private network operator. It may be co-located with, or physically a part of a public exchange.

**channel:** See physical channel.

**cluster:** A logical grouping of one or more cells between which bearer handover is possible. A Cluster Control Function (CCF) controls one cluster.

NOTE 10: Internal handover to a cell which is not part of the same cluster can only be done by connection handover.

**connection:** See "MAC connection".

**connection handover:** The internal handover process provided by the DLC layer, whereby one set of DLC entities (C-plane and U-plane) can re-route data from one MAC connection to a second new MAC connection, while maintaining the service provided to the NWK layer.

NOTE 11: Connection handover is DLC frame based.

**Connectionless mode (C/L):** A transmission mode that transfers one packet (one self contained unit) of data from one source point to one (or more) destination points in a single phase.

NOTE 12: Connectionless transmissions require the peer-to-peer associations to be prearranged, and the transmission is unacknowledged at that layer.

**Connection Oriented mode (C/O):** A transmission mode that transfers data from one source point to one or more destination points using a protocol based on three phases: "Set-up", "Data transfer" and "Release".

NOTE 13: C/O mode requires no prearranged associations between peer entities (unlike C/L mode).

**Cordless Radio Fixed Part (CRFP):** A Wireless Relay Station (WRS) that provides independent bearer control to a PT and FT for relayed connections.

**coverage area:** The area over which reliable communication can be established and maintained.

**DECT Network (DNW):** A network that uses the DECT air interface to interconnect a local network to one or more portable applications. The logical boundaries of the DECT network are defined to be at the top of the DECT NWK layer.

NOTE 14: A DNW is a logical grouping that contains one or more Fixed radio Terminations (FTs) plus their associated Portable radio Termination (PT). The boundaries of the DECT network are not physical boundaries.



**DLC broadcast:** A simplex "connectionless" mode of transmission from the DLC broadcast entity of one FT to the DLC broadcast entities in one or more PT.

NOTE 15: The transmitter may disregard the presence or absence of receivers.

**DLC data link (DLC link):** An association between two DLC layer entities. This can either be one C-plane association or one U-plane association.

NOTE 16: This is not the same as a MAC connection.

**DLC frame:** The format used to structure all messages that are exchanged between DLC layer peer entities.

NOTE 17: Different DLC frames are used in the C-plane and the U-plane, and there is more than one format of DLC frame in each plane.

**double duplex bearer:** The use of two duplex bearers (see duplex bearer) which refer to the same MAC connection, sharing their simplex bearers (see simplex bearer) for the information flow.

**double-simplex bearer:** The use of two simplex bearers operating in the same direction on two physical channels. These pairs of channels always use the same RF carrier and always use evenly spaced slots (i.e. separated by 0,5 Time Division Multiple Access (TDMA) frame).

A double-simplex bearer only exists as part of a multibearer MAC connection.

**down-link:** Transmission in the direction FT to PT.

**duplex bearer:** The use of two simplex bearers operating in opposite directions on two physical channels. These pairs of channels always use the same RF carrier and always use evenly spaced slots (i.e. separated by 0,5 TDMA frame).

**End System (ES):** A logical grouping that contains application processes and supports telecommunication services.

NOTE 18: From the OSI point of view, end systems are considered as sources and sinks of information.

**external handover:** The process of switching a call in progress from one FP to another FP.

**field:** A continuous region of data (i.e. adjacent bits) that jointly convey information. Typically, a message will contain several fields. If data is not continuous then it is defined as two (or more) fields.

**Fixed Part (DECT Fixed Part) (FP):** A physical grouping that contains all of the elements in the DECT network between the local network and the DECT air interface.

NOTE 19: A DECT FP contains the logical elements of at least one FT, plus additional implementation specific elements.

**Fixed radio Termination (FT):** A logical group of functions that contains all of the DECT processes and procedures on the fixed side of the DECT air interface.

NOTE 20: A FT only includes elements that are defined in EN 300 175 parts 1 to 8 [1] to [7]. This includes radio transmission elements (layer 1) together with a selection of layer 2 and layer 3 elements.

**flow control:** The mechanism that is used to regulate the flow of data between two peer entities.

**fragment:** One of the Service Data Units (SDUs) that is produced by the process of fragmentation.

NOTE 21: This is not the same as a segment.

**fragmentation:** The process of dividing a Protocol Data Unit (PDU) into more than one SDU for delivery to a lower layer. The reverse process is recombination.

NOTE 22: This is not the same as segmentation.

**frame:** See TDMA frame or DLC frame.

**full slot (slot):** One 24th of a TDMA frame which is used to support one physical channel.

**generic:** A generalized set or general purpose set, often in the sense of basic or ordinary.

**geographically unique:** This term relates to FP identities, Primary Access Rights Identifiers (PARIs) and Radio Fixed Part Identifiers (RFPIs). It indicates that two FPs with the same PARI, or respectively two RFPIs with the same RFPI, can not be reached or listened to at the same geographical position.

**Global NetWork (GNW):** A telecommunication network capable of offering a long distance telecommunication service.

NOTE 23: The term does not include legal or regulatory aspects, nor does it indicate if the network is a public or a private network.

**globally unique identity:** The identity is unique within DECT (without geographical or other restrictions).

**guard space:** The nominal interval between the end of a radio transmission in a given slot, and the start of a radio transmission in the next successive slot.

NOTE 24: This interval is included at the end of every slot, in order to prevent adjacent transmissions from overlapping even when they originate with slightly different timing references (e.g. from different radio end points).

**half slot:** One 48th of a TDMA frame which is used to support one physical channel.

**handover:** The process of switching a call in progress from one physical channel to another physical channel. These processes can be internal (see internal handover) or external (see external handover).

NOTE 25: There are two physical forms of handover, intracell handover and intercell handover. Intracell handover is always internal, intercell handover can be internal or external.

**incoming call:** A call received at a PP.

**intercell handover:** The switching of a call in progress from one cell to another cell.

**internal handover:** Handover processes that are completely internal to one FT. Internal handover reconnects the call at the lower layers, while maintaining the call at the NWK layer.

NOTE 26: The lower layer reconnection can either be at the DLC layer (see connection handover) or at the MAC layer (see bearer handover).

**interoperability:** The capability of FPs and PPs, that enable a PP to obtain access to teleservices in more than one location area and/or from more than one operator (more than one service provider).

**interoperator roaming:** Roaming between FP coverage areas of different operators (different service providers).

**Interworking Unit (IWU):** A unit that is used to interconnect subnetworks.

NOTE 27: The IWU will contain the InterWorking Functions (IWF) necessary to support the required subnetwork interworking.

**intracell handover:** The switching of a call in progress from one physical channel of one cell to another physical channel of the same cell.

**intraoperator roaming:** Roaming between different FP coverage areas of the same operator (same service provider).

**link:** See DLC data link.

**Local Network (LNW):** A telecommunication network capable of offering local telecommunication services.

NOTE 28: The term does not include legal or regulatory aspects, nor does it indicate if the network is a public network or a private network.

**locally unique identity:** The identity is unique within one FP or location area, depending on application.

**location area:** The domain in which a PP may receive (and/or make) calls as a result of a single location registration.

**location registration:** The process whereby the position of a DECT portable termination is determined to the level of one location area, and this position is updated in one or more databases.

NOTE 29: These databases are not included within the DECT FT.

**logical channel:** A generic term for any distinct data path. Logical channels can be considered to operate between logical end points.

**Lower Layer Management Entity (LLME):** A management entity that spans a number of lower layers, and is used to describe all control activities which do not follow the rules of layering.

NOTE 30: The DECT LLME spans the NWK layer, the DLC layer, the MAC layer and the PHL.

**MAC bearer (bearer):** MAC bearers are the service elements that are provided by each Cell Site Function (CSF). Each MAC bearer corresponds to a single service instance to the physical layer. See also simplex bearer, duplex bearer and double simplex bearer.

**MAC connection (connection):** An association between one source MAC Multi-Bearer Control (MBC) entity and one destination MAC MBC entity. This provides a set of related MAC services (a set of logical channels), and it can involve one or more underlying MAC bearers.

**multiframe:** A repeating sequence of 16 successive TDMA frames, that allows low rate or sporadic information to be multiplexed (e.g. basic system information or paging).

**network (telecommunication network):** All the means of providing telecommunication services between a number of locations where the services are accessed via equipment attached to the network.

**node:** A point at which switching occurs.

**operator (DECT operator):** The individual or entity who or which is responsible for operation of one or more DECT FPs.

NOTE 31: The term does not imply any legal or regulatory conditions, nor does it imply any aspects of ownership.

**outgoing call:** A call originating from a PP.

**paging:** The process of broadcasting a message from a DECT FP to one or more DECT PPs.

NOTE 32: Different types of paging message are possible. For example, the {Request paging} message orders the recipient to respond with a call set-up attempt.

**paging area:** The domain in which the PP will be paged as a part of incoming call establishment.

NOTE 33: In general, the paging area will be equal to the Temporary Portable User Identity (TPUI) domain, since the TPUI is used for paging.

**phase:** One discrete part of a procedure, where the start and end of the part can be clearly identified (e.g. by the arrival or dispatch of a primitive).

**physical channel (channel):** The simplex channel that is created by transmitting in one particular slot on one particular RF channel in successive TDMA frames. See also simplex bearer.

NOTE 34: One physical channel provides a simplex service. Two physical channels are required to provide a duplex service.

**Portable Application (PA):** A logical grouping that contains all the elements that lie beyond the DECT network boundary on the portable side.

NOTE 35: The functions contained in the portable application may be physically distributed, but any such distribution is invisible to the DECT network.

**Portable Handset (PHS):** A single physical grouping that contains all of the portable elements that are needed to provide a teleservice to the user.

NOTE 36: PHS is a subset of all possible portable parts. This subset includes all physical groupings that combine one PT plus at least one portable application in a single physical box.

**Portable Part (DECT Portable Part) (PP):** A physical grouping that contains all elements between the user and the DECT air interface. PP is a generic term that may describe one or several physical pieces.

NOTE 37: A DECT PP is logically divided into one PT plus one or more portable applications.

**Portable radio Termination (PT):** A logical group of functions that contains all of the DECT processes and procedures on the portable side of the DECT air interface.

NOTE 38: A PT only includes elements that are defined in EN 300 175 [1] to [7]. This includes radio transmission elements (layer 1) together with a selection of layer 2 and layer 3 elements.

**primitive:** A distinct (but abstract) data element that is passed between adjacent protocol layers.

NOTE 39: A service primitive contains one SDU.

**private:** An attribute indicating that the application of the so qualified term, e.g. a network, an equipment, a service, is offered to, or is in the interest of, a determined set of users.

NOTE 40: The term does not include any legal or regulatory aspects, nor does it indicate any aspects of ownership.

**public:** An attribute indicating that the application of the so qualified term, e.g. a network, an equipment, a service, is offered to, or is in the interest of, the general public.

NOTE 41: The term does not include any legal or regulatory aspects, nor does it indicate any aspects of ownership.

**Public Access Profile (PAP):** A defined part of this ETS, i.e. ETS 300 175 9 [8] that profile which ensures interoperability between FPs and PPs for public access services.

**public access service:** A service that provides access to a public network for the general public.

NOTE 42: The term does not imply any legal or regulatory aspect, nor does it imply any aspects of ownership.

**radio channel:** No defined meaning. See RF channel or physical channel.

**radio end point:** A physical grouping that contains one radio transceiver (transmitter/receiver), fixed or portable.

NOTE 43: A radio end point may operate only as a receiver or only as a transmitter.

**Radio Fixed Part (RFP):** One physical sub-group of a FP that contains all the radio end points (one or more) that are connected to a single system of antennas.

**registration:** An ambiguous term, that should always be qualified. See either location registration or subscription registration.

**Repeater Part (REP):** A WRS that relays information within the half frame time interval.

**RF carrier (carrier):** The centre frequency occupied by one DECT transmission.

**RF channel:** The nominal range of frequencies (RF spectrum) allocated to the DECT transmissions of a single RF carrier.

**roaming:** The movement of a PP from one FP coverage area to another FP coverage area, where the capabilities of the FPs enable the PP to make or receive calls in both areas.

NOTE 44: Roaming requires the relevant FPs and PPs to be interoperable.

**roaming service:** A service which can be used in more than one FP coverage area.

**segment:** One of the pieces of data that is produced by the process of segmentation.

NOTE 45: In general, one segment only represents a portion of a complete message.

**segmentation:** The process of partitioning one SDU from a higher layer into more than one PDU. The reverse process is assembly.

**service provider (telecommunications service provider):** The individual, or entity, who, or which, interfaces to the customer in providing telecommunications service.

NOTE 46: The term does not imply any legal or regulatory conditions, nor does it indicate whether public service or private service is provided.

NOTE 47: The term service provider is also used with a different meaning in the ISO/OSI layered model.

**sequencing (sequence numbering):** The process of adding a sequence number to a set of data packets so that the packets can be reassembled in the correct order, regardless of the order they are received. See also segmentation.

**simplex bearer:** A simplex bearer is the MAC layer service that is created using one physical channel. See also duplex bearer and double simplex bearer.

**Single Radio Fixed Part (SRFP):** A radio FP that contains only one radio end point.

NOTE 48: The SRFP is defined for DECT system analysis. Unless otherwise stated, a SRFP is assumed to support multiple calls, and is limited only by the capacity of its single radio end point.

**subscriber (customer):** The natural person, or the juristic person who has subscribed to telecommunication services, and is, therefore, responsible for payment.

**subscription registration:** The infrequent process whereby a subscriber obtains access rights to one or more FPs.

NOTE 49: Subscription registration is usually required before a user can make or receive calls.

**Supplementary Service (SS):** A service that modifies or supplements a basic telecommunication service.

NOTE 50: Three functional groups of SSs are defined for DECT:

- 1) DECT TRANSPARENT supplementary services:
  - the service elements are unspecified within the present document;
- 2) DECT STANDARD supplementary services:
  - the service elements are specified within the present document by reference to other standards;
- 3) DECT SPECIFIC supplementary services:
  - the service elements are fully specified within the present document.

**switching:** The process of interconnecting functional units, transmission channels or telecommunication circuits for as long as required to convey signals.

**TDMA frame:** A time-division multiplex of 10 ms duration containing 24 successive full slots. A TDMA frame starts with the first bit period of full slot 0 and ends with the last bit period of full slot 23.

**telecommunication:** Any transmission and/or emission and/or reception of signals representing signs, writings, images, and sounds or intelligence of any nature by wire, radio, optical or other electromagnetic systems.

**teleservice:** A type of telecommunication service that provides the complete capability, including terminal equipment functions, for communication between users, according to protocols that are established by agreement.

**TPUI domain:** The domain over which every TPUI is (locally) unique.

NOTE 51: In general, the TPUI domain will be equal to the paging area and thereby equal to the location area.

**U-plane:** The user plane of the DECT protocol stacks. This plane contains most of the end-to-end (external) user information and user control.

NOTE 52: The U-plane protocols do not include any internal DECT protocol control, and it may be null at the NWK layer and at the DLC layers for some services.

**up link:** Transmission in the direction PT to FT.

**user (of a telecommunication network):** A person or machine delegated by a subscriber (by a customer) to use the services, and/or facilities, of a telecommunication network.

**Wireless Relay Station (WRS):** A physical grouping that combines elements of both PTs and FTs to relay information on a physical channel from one DECT termination to a physical channel to another DECT termination.

NOTE 53: The DECT termination can be a PT or an FT or another WRS.

## 3.2 Abbreviations

For the purposes of the present document the following abbreviations apply.

AC	Authentication Code
ACP	Adjacent Channel Power
ACK	Acknowledgement
ADPCM	Adaptive Differential Pulse Code Modulation
ARC	Access Rights Class
ARD	Access Rights Details
ARI	Access Rights Identity
ARQ	Automatic Repeat reQuest
BCD	Binary Coded Decimal
BMC	Broadcast Message Control
CBC	Connectionless Bearer Control
CC	Call Control
CCF	Cluster Control Function
CCFP	Central Control Fixed Part
CEP	Connection End Point
CI	Common Interface
CK	Cipher Key
CODEC	Coder-Decoder
CLMS	Connectionless Message Service
CMC	Connectionless Message Control
COMS	Connection Oriented Message Service
C-Plane	Control Plane
CRC	Cyclic Redundancy Check
CRFP	Cordless Radio Fixed Part
CSF	Cell Site Function
CSPDN	Circuit Switched Public Data Network
CX	Co-Existence standard
C/L	Connectionless mode
C/O	Connection Orientated mode
DAM	DECT Authentication Module
DBC	Dummy Bearer Control
dBc	dB relative to the peak power of an unmodulated carrier
dBm	dB relative to 1 milliwatt
DCK	Derived Cipher Key
DECT	Digital Enhanced Cordless Telecommunications
DLC	Data Link Control
DLEI	Data Link Endpoint Identifier
DLI	Data Link Identifier
DNW	DECT Network
DSAA	DECT Standard Authentication Algorithm
DSC	DECT Standard Cipher

ERP	Effective Radiated Power
ES	End System
FMID	Fixed part MAC Identity
FP	Fixed Part
FT	Fixed radio Termination
GFSK	Gaussian Frequency Shift Keying
GNW	Global NetWork
HDB	Home Data Base
IA5	International Alphabet No. 5
IFEI	International Fixed Equipment Identity
IPEI	International Portable Equipment Identity
IPIU	International Portable User Identity
IRC	Idle Receiver Control
ISDN	Integrated Services Digital Network
IWF	Interworking Functions
IWU	Interworking Unit
K	authentication Key
KS	PP authentication Session Key
KS'	FP authentication Session Key
KSG	Key Stream Generator
KSS	Key Stream Segment
LAPC	a DLC layer C-plane protocol entity
LAN	Local Area Network
LBN	Logical Bearer Number
LCE	Link Control Entity
LCN	Logical Connection Number
LLME	Lower Layer Management Entity
LLN	Logical Link Number
LNW	Local Network
MAC	Medium Access Control
MBC	Multiple Bearer Control
MCEI	MAC Connection Endpoint Identification
MM	Mobility Management
MUX	time MULTipleXor
NWK	Network layer
OSI	Open Systems Interconnection
PA	Portable Application
PAP	Public Access Profile
PARI	Primary Access Rights Identity
PARK	Portable Access Rights Key
PARK{y}	PARK with value y for it's Park length indicator
PBX(PABX)	Private Automatic Branch Exchange
PCI	Protocol Control Information
PDU	Protocol Data Unit
PHL	PHysical Layer
PHS	Portable Handset
PLI	Park Length Indicator
PMID	Portable part MAC IDentity
POT(S)	Plain Old Telephone (Service)
PP	Portable Part
PSPDN	Packet Switched Public Data Network
PSTN	Public Switched Telephone Network
PT	Portable radio Termination
PTN	Private Telecommunication Network
PUN	Portable User Number
PUT	Portable User Type
RAND_F	a Random challenge issued by a FT
RAND_P	a Random challenge issued by a PT
REP	Repeater Part
RES1	a Response calculated by a PT

RES2	a Response calculated by an FT
RF	Radio Frequency
RFP	Radio Fixed Part
RFPI	Radio Fixed Part Identity
RPN	Radio fixed Part Number
RS	a value used to establish authentication session keys
RSSI	Radio Signal Strength Indicator
SAP	Service Access Point
SARI	Secondary Access Rights Identity
SCK	Static Cipher Key
SDU	Service Data Unit
SS	Supplementary Services
TARI	Tertiary Access Rights Identity
TBC	Traffic Bearer Control
TDD	Time Division Duplex
TDMA	Time Division Multiple Access
TI	Transaction Identifier
TPUI	Temporary Portable User Identity
UAK	User Authentication Key
UPI	User Personal Identification
U-Plane	User Plane
VDB	Visitors Data Base
WRS	Wireless Relay Station
XRES1	an Expected Response calculated by a FT
XRES2	an Expected Response calculated by a PT

---

## 4 Structure

The present document consists of 9-8 parts (parts 1 to 9-8 inclusive) which are briefly described in subclauses 4.1 to ~~4-9~~ 4.8.

Parts 2 to 5 inclusive specify the air interface. They are structured into layers corresponding to the lower layers of the ISO OSI model. Part 6 specifies the identities and addressing structure and part 7 specifies the security features. Part 8 specifies speech aspects and ~~Part 9 specifies the Public Access Profile (PAP)~~.

In addition there exists a DECT approval test specification EN 300 176 [9] which is not described in the present document.

### 4.1 Part 1: Overview

The overview contains an introduction to the complete European Standard. It includes a description of the system and the protocol architecture and a vocabulary of terms.

### 4.2 Part 2: Physical Layer (PHL)

The PHL specifies radio parameters such as the frequency, timing and power values, the bit and slot synchronization and the transmitter and receiver performance.

### 4.3 Part 3: Medium Access Control (MAC) layer

The MAC layer specifies three groups of MAC services. These are the broadcast message control service, the connectionless message control service and the multi-bearer control service. It also specifies the logical channels, which are used by the above mentioned services, and how they are multiplexed and mapped on to the physical channels.



## 4.4 Part 4: Data Link Control (DLC) layer

The DLC layer specifies two groups of DLC services. These are the services for the C-plane and the services for the U-plane.

For the C-plane a point-to-point service and a broadcast service are defined. The point-to-point service can operate in acknowledged or unacknowledged mode and provides addressing, frame delimiting, error control, flow control, segmentation of network layer information fields, fragmentation of DLC frames and connection handover.

For the U-plane the transparent unprotected service, the frame relay service, the frame switching service and the rate adaptation service are defined.

## 4.5 Part 5: Network (NWK) layer

The NWK layer specifies the functions for the link control, the Call Control (CC), the Supplementary Services (SS), the Connection Oriented Message Service (COMS), the Connectionless Message Service (CLMS) and the Mobility Management (MM). For these groups it contains the procedures, messages and information elements.

## 4.6 Part 6: Identities and addressing

The identities and addressing specifies the main identities and addresses which are used in DECT. They are divided into the following four categories: FP identities, PP identities, connection related identities and equipment related identities.

Several of the FP identities and PP identities are allocated centrally in order to maintain global uniqueness for these identities.

## 4.7 Part 7: Security features

The security features specify the overall security architecture for DECT, the types of cryptographic algorithms required and the way in which they are to be used, and the requirements for integrating the security features provided by the architecture into the DECT air interface. It also describes how the features may be managed and how they relate to certain DECT fixed systems and local network configurations.

## 4.8 Part 8: Speech coding and transmission

The speech coding and transmission specifies the requirements for DECT equipment which includes all the necessary functions to provide real-time two-way speech conversation. It defines the speech encoding algorithm and the detailed speech performance characteristics such as sensitivity, frequency response, sidetone, terminal coupling loss, distortion, variation of gain with input level, out of band signals, noise, acoustic shock, delay and network echo control.

A 3,1 kHz telephony teleservice conveyed over a DECT link (including FP and PP) which is capable of being connected (directly or indirectly) to the public network access point shall comply with the requirements in EN 300 175-8 [7].

Furthermore, all DECT implementations capable of voice transmission that are not required to comply with EN 300 175-8 [7] shall not use more than 20 % of the available physical channels for connections that use more than one full slot duplex bearer.

Tethered fixed point local loop applications are not required to comply with the requirements of EN 300 175-8 [7].

## ~~4.9 Part 9: Public Access Profile (PAP)~~

~~The PAP specifies the mandatory (minimum) and optional requirements for DECT equipment offering, or using, public access services. This profile specifies an interoperable subset of the protocol independently for FPs and PPs, by detailed references to the other parts of the present document.~~

---

## 5 The objectives of the CI standard

The DECT standard has grown out of the need to provide cordless communications, primarily for voice traffic, and also to provide support for a range of data traffic requirements.

The DECT standard is designed to support this versatility of applications at a cost that encourages wide adoption. It is envisaged that DECT will provide personal telecommunication services in residential, neighbourhood and business environments. It is particularly targeted at the following applications:

- residential - domestic cordless telephones;
- public access services;
- cordless business telephones (PBXs);
- cordless data - Local Area Networks (LANs);
- evolutionary applications (extensions to cellular radio, and extensions of the local public network).

One primary objective of this CI standard is to provide for interoperability between equipment of different origin, so offering users a family of telecommunication services for voice or data, either as basic services, or with optional (and compatible) extensions.

While providing for compatibility, the present document provides standard escape routes that allow manufacturers to retain options for innovation and product differentiation (see clause 8). In addition, reserved codes have been included in the present document to provide mechanisms for evolutionary development of the present document. At the same time, the existence of this common standard allows implementors to design systems that can provide telecommunications to users in several different locations.

At a more detailed level, the protocols in this document are designed to provide for the specific services and facilities defined in ETR 043 [12] and CEPT Recommendation T/SGT SF2 (89) 6/0 [15]. In the design process, the following additional objectives were considered:

- the structure should allow any other reasonable application;
- the structure should allow any reasonable implementation.

Lastly, the present document also has the objective of regulating the use of, and interface of, two shared resources:

- the RF spectrum which is allocated to provide for the cordless operation of the communication system; and
- one or more networks for which the DECT network provides cordless connection.

It is the objective of the present document to ensure that conforming equipment will be able to use the above resources efficiently and with the minimum degree of mutual interference, i.e. avoiding adverse affects to existing, or future, users of those resources - see also CCIR Report 662 [16].

---

## 6 General description of the system

DECT is based on a micro-cellular radio communication system that provides low-power radio (cordless) access between PPs and (DECT) FPs at ranges up to a few hundred metres. The basic technical characteristics are as follows:

- frequency band: 1 880 - 1 900 MHz;
- number of carriers: 10;
- carrier spacing: 1,728 MHz;
- peak transmit power: 250 mW;
- carrier multiplex: TDMA; 24 slots per frame;
- frame length: 10 ms;
- basic duplexing: TDD using 2 slots on same RF carrier;
- gross bit rate: 1 152 kbit/s;
- net channel rates: 32 kbit/s B-field (traffic) per slot;  
6,4 kbit/s A-field (control/signalling) per slot.

A connection is provided by transmitting bursts of data in the defined time slots. These may be used to provide simplex or duplex communications. Duplex operation uses a pair of evenly spaced slots; one for transmit and one for receive.

The simplest duplex service uses a single pair of time slots to provide a 32 kbit/s digital information channel capable of carrying coded speech or other low rate digital data. Higher data rates are achieved by using more time slots in the TDMA structure, and a lower data rate may be achieved by using half-slot data bursts.

DECT is able to support a number of alternative system configurations ranging from single cell equipment (e.g. domestic FPs) to large multiple cell installations (e.g. large business cordless PBXs).

The protocols are designed to support uncoordinated system installation, even where the systems co-exist in the same physical location. Efficient sharing of the radio spectrum (of the physical channels) is achieved using a careful mechanism for selection of channels prior to their use. This is called dynamic channel selection (see ETR 042 [11]).

In addition, the DECT protocols provide two internal mechanisms to support rapid handover of calls in progress (both intracell and intercell handover are supported). These handover mechanisms allows a high quality of service to be maintained where the mobility of the PP requires transparent re-connection to another FP or where a new physical channel is required in response to a disturbances in the radio environment. The importance of handover is discussed in ETR 042 [11].

Direct communication from PT to PT is also supported.

## 7 Description of the protocol architecture

### 7.1 General

The structure of the present document is based on the layered principles used in the ISO Open Systems Interconnection (OSI) model. The complete CI corresponds to the lower 3 layers of the ISO OSI model, but DECT defines 4 layers of protocol. These lower layers differ from the OSI model because the OSI model takes no account of either the uncertainties introduced by using radio transmissions at the PHL or of the concept of handover.

### 7.2 The DECT layered structure

A structure of four layers is used for the signalling protocols as shown in figure 1.

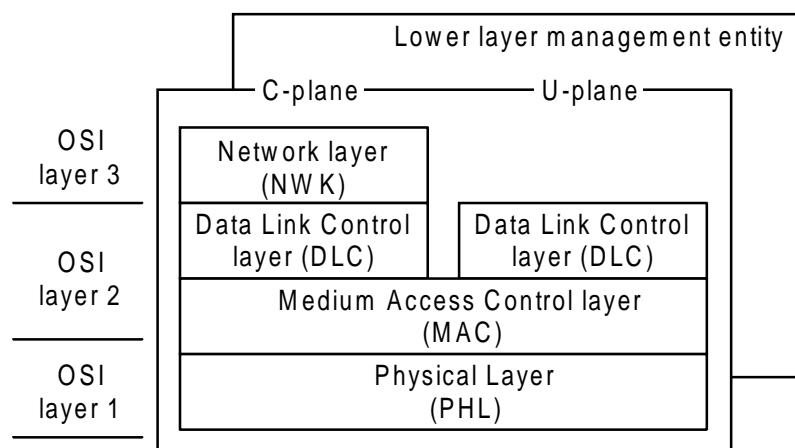

**Figure 1: The layered structure**

The top of the NWK layer corresponds to the top of the OSI layer 3. The intermediate boundaries have no OSI equivalent but for ease of understanding an approximate correspondence is given below:

- OSI Layer 1: all of the PHL plus part of MAC layer;
- OSI Layer 2: most of MAC layer plus all of DLC;
- OSI Layer 3: all of the NWK layer.

### 7.3 Physical Layer (PHL)

The PHL divides the radio spectrum into the physical channels. This division occurs in two fixed dimensions, frequency and time.

The frequency and time division uses Time Division Multiple Access (TDMA) operation on multiple RF carriers. Ten carriers are provided in the frequency band 1 880 to 1 900 MHz. This standard also provides for possible extensions of the band to meet future demand. On each carrier the TDMA structure defines 24 timeslots in a 10 ms frame, where each timeslot may be used to transmit one self contained packet of data. Each transmitted packet contains a synchronization field, together with control information, service information and error control.

**NOTE:** In addition the radio spectrum is divided spatially into cells, where the same physical channels may be re-used in different (geographic) locations. The spatial re-use operates according to the principles of Dynamic Channel Selection (DCS) as described in ETR 042 [11] dealing with DECT features.

Each FP radio end point operates according to a local timing reference and the PHL is then responsible for transmitting packets of data under direct control of the MAC layer. Adjacent FPs may be synchronized. This provides some advantages, particularly in high traffic situations (see ETR 042 [11]).

## 7.4 MAC layer

The MAC layer performs two main functions. Firstly, it selects physical channels, and then establishes and releases connections on those channels. Secondly, it multiplexes (and demultiplexes) control information, together with higher layer information and error control information, into slot-sized packets.

These functions are used to provide three independent services; a broadcast service, a connection oriented service and a connectionless service.

The broadcast service is a special DECT feature: it multiplexes a range of broadcast information into a reserved field (the A-field), and this field appears as part of all active transmissions. The broadcast service is always transmitted in every cell (even in the absence of user traffic) on at least one physical channel. These "beacon" transmissions allow PPs to quickly identify all FPs that are within range, to select one, and to lock to it without requiring any portable transmissions.

## 7.5 DLC layer

The DLC layer is concerned with the provision of very reliable data links to the NWK layer. Many of the imperfections of the radio transmissions are already removed by the efforts of the MAC layer, and the DLC layer is designed to work closely with the MAC layer to provide higher levels of data integrity than can be provided by the MAC layer alone.

The DECT layered model separates into two planes of operation at the DLC layer; the C-plane and the U-plane.

The C-plane is common to all applications, and provides very reliable links for the transmission of internal control signalling and limited quantities of user information traffic. Full error control is provided with a balanced Link Access Protocol (LAPC).

The U-plane provides a family of alternative services, where each service is optimized to the particular need of a specific type of services. The simplest service is the transparent unprotected service used for speech transmission. Other services support circuit mode and packet mode data transmission, with varying levels of protection.

## 7.6 Network (NWK) layer

The NWK layer is the main signalling layer of the protocol. It adopts a similar style to the ISDN layer 3 protocol (see EN 300 403 [14]) and offers a similar level of functions.

The NWK layer operates using an exchange of messages between peer entities. The basic set of messages supports the establishment, maintenance and release of calls. Additional messages support a range of extended capabilities.

The basic CC provides a circuit switched service selected from one of the range of DLC options. Other network layer services are SS, COMS, CLMS and MM. These services are arranged as independent entities, and a particular application can be realized using more than one.

The MM is a particularly important group of services. This group contains the procedures that support the special cordless mobility of PPs, for example authentication and location registration.

## 7.7 Lower Layer Management Entity (LLME)

The LLME contains defined procedures that concern more than one layer. The LLME procedures are included in EN 300 175 parts 3 to 5, [2] to [4]. Most of these procedures have only local significance, and they are defined in general terms to allow for alternative implementations. The location of some selected LLME procedures is as follows:

MAC layer:

- creation, maintenance and release of bearers, by activating and deactivating pairs of physical channels;
- physical channel management, including the choice of free physical channels and the assessment of the quality of received signals.

DLC layer:

- connection management, which includes the establishment and release of connections in response to NWK layer demands;
- routing of C-plane and U-plane data to suitable connections.

NWK layer:

- service negotiation and mapping.

## 7.8 Interworking Units (IWU)

Transport of the information to the end user requires additional layers of protocol that are outside the scope of the present document. In general, an IWU will be required to provide the necessary interworking functions. This IWU plays a important role in defining the exact service that is provided. Guidance on possible interworking arrangements for the target applications can be found in ETR 056 [13], clause 7.

---

## 8 Proprietary escapes within the CI

A set of defined escape routes have been provided for implementors that wish to implement proprietary additions or alternatives to the CI protocol, as shown in figure 2.

### 8.1 Primary escape routes

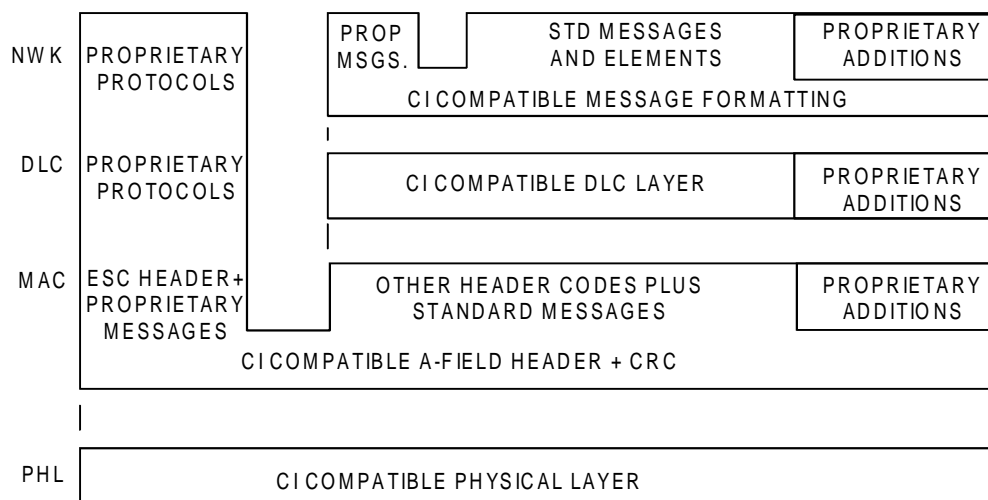

Figure 2: Structure of escape routes within the CI

Two primary escape routes are defined within the CI standard, one at the MAC layer and one at the NWK layer. In both cases these escape routes provide the possibility for manufacturers to branch into a family of proprietary protocols. These branches provide a compatible method for proprietary systems to operate without causing confusion or interference to systems that implement the other CI provisions.

The lowest branch occurs at the MAC layer. The branch is defined at this level in order to ensure a minimum level of conformance to the CI. The minimum level of conformance therefore includes all of the PHL and the lower parts of the MAC layer (in particular, the MAC A-field header, A-field CRC and the channel selection procedures).

This MAC branch operates by using one reserved code in the MAC header field (the field that appears at the start of every transmission - see EN 300 175-3 [2]). All equipment shall understand this reserved code. This reserved code shall be used in every transmission from proprietary equipment and shall never be used by equipment that conforms to the standard branch. This means that transmissions from proprietary systems can be immediately identified by all other equipment.

For approvals testing purposes a small number of standard messages shall be supported by proprietary equipment when operating in a special test mode. No messages are mandated for proprietary equipment in normal operating mode.

At the NWK layer the escape route operates by using a reserved protocol discriminator code. All equipment shall understand this code, it shall be used exclusively by proprietary protocols (other codes are reserved for the standard protocols) to clearly indicate that a proprietary protocol is in use. In this case proprietary protocols can co-exist with standard protocols as part of the same equipment.

## 8.2 Secondary escape routes

In addition to these primary escape routes, a series of secondary escape routes are defined at all layers using reserved codes or optional elements, as appropriate. These small branches allow proprietary information to be included in addition to the CI information. They are designed to allow manufactures to enhance the CI with proprietary features without compromising the basic level of interoperability.

---

## 9 Levels of conformance

The following levels of CI conformance are defined:

CI-PROFILE-PLUS	ETSI approved CI operating profile(s) with proprietary extensions;
CI-PROFILE	ETSI approved CI operating profile(s) (e.g. PAP);
CI-BASE	PHL and minimum MAC conformance.

The CI-Base defines the minimum level of conformance to the CI standard. This shall apply to all DECT equipment. It does not imply any speech transmission characteristics.

---

# History

<b>Document history</b>		
Edition 1	October 1992	Publication as ETS 300 175-1
Edition 2	September 1996	Publication as ETS 300 175-1
V1.4.1	February 1998	Public Enquiry PE 9824: 1998-02-13 to 1998-06-12