

**Transmission and Multiplexing (TM);
Synchronous Digital Hierarchy (SDH);
Multiplexing structure**

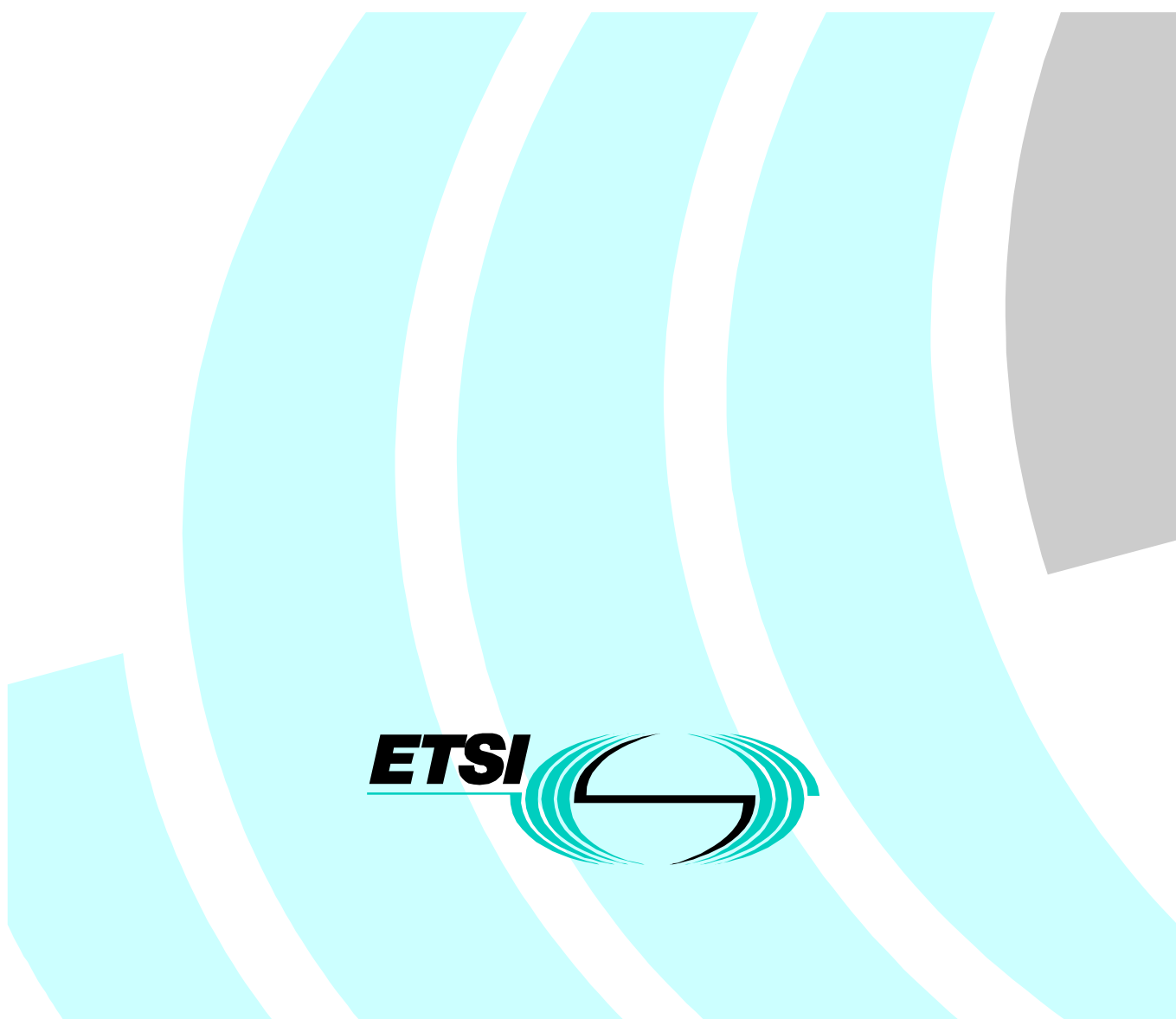

Reference

REN/TM-01063

Keywords

architecture, MUX, SDH, Transmission

ETSI

650 Route des Lucioles
F-06921 Sophia Antipolis Cedex - FRANCE

Tel.: +33 4 92 94 42 00 Fax: +33 4 93 65 47 16

Siret N° 348 623 562 00017 - NAF 742 C
Association à but non lucratif enregistrée à la
Sous-Préfecture de Grasse (06) N° 7803/88

Important notice

Individual copies of the present document can be downloaded from:

<http://www.etsi.org>

The present document may be made available in more than one electronic version or in print. In any case of existing or perceived difference in contents between such versions, the reference version is the Portable Document Format (PDF). In case of dispute, the reference shall be the printing on ETSI printers of the PDF version kept on a specific network drive within ETSI Secretariat.

Users of the present document should be aware that the document may be subject to revision or change of status. Information on the current status of this and other ETSI documents is available at <http://www.etsi.org/tb/status/>

If you find errors in the present document, send your comment to:
editor@etsi.fr

Copyright Notification

No part may be reproduced except as authorized by written permission.
The copyright and the foregoing restriction extend to reproduction in all media.

© European Telecommunications Standards Institute 2001.
All rights reserved.

Contents

Intellectual Property Rights	4
Foreword.....	4
Introduction	4
1 Scope	5
2 References	5
3 Definitions, abbreviations and conventions	5
3.1 Definitions	5
3.2 Abbreviations	5
3.3 Conventions.....	6
4 Basic multiplexing principles	6
5 Multiplexing method	8
6 Pointers.....	9
7 Overhead bytes description	10
8 Mapping of tributaries into VC-n	11
9 VC Concatenation	11
10 Statements to the annexes.....	12
11 Conformance testing.....	12
Annex A (normative): G.707 corrigendum	14
Annex B (informative): Bibliography.....	19
History	20

Intellectual Property Rights

IPRs essential or potentially essential to the present document may have been declared to ETSI. The information pertaining to these essential IPRs, if any, is publicly available for **ETSI members and non-members**, and can be found in ETSI SR 000 314: "*Intellectual Property Rights (IPRs); Essential, or potentially Essential, IPRs notified to ETSI in respect of ETSI standards*", which is available from the ETSI Secretariat. Latest updates are available on the ETSI Web server (<http://www.etsi.org/ipr>).

Pursuant to the ETSI IPR Policy, no investigation, including IPR searches, has been carried out by ETSI. No guarantee can be given as to the existence of other IPRs not referenced in ETSI SR 000 314 (or the updates on the ETSI Web server) which are, or may be, or may become, essential to the present document.

Foreword

This European Standard (Telecommunications series) has been produced by ETSI Technical Committee Transmission and Multiplexing (TM), and is now submitted for the ETSI standards One-step Approval Procedure.

The present document specifies the physical and electrical characteristics of hierarchical interfaces based on IUT-T Recommendation G.707 [1] but it does not intend to preclude the use of interfaces covered in other standards.

The aim of the present document is to provide inter-vendor and inter-operator compatibility.

The conformance testing requirements corresponding to the specifications contained in the present document are to be specified in a different EN.

Physical parameters for optical interfaces for the Synchronous Digital Hierarchy (SDH) are to be specified in a different standard which is under development.

Proposed national transposition dates	
Date of latest announcement of this EN (doa):	3 months after ETSI publication
Date of latest publication of new National Standard or endorsement of this EN (dop/e):	6 months after doa
Date of withdrawal of any conflicting National Standard (dow):	6 months after doa

Introduction

The present document is a delta document based on ITU Recommendation G.707 [1].

1 Scope

The present document specifies the hierarchical bit rates, the multiplexing structure and the mapping schemes to be used in the transmission networks based on the Synchronous Digital Hierarchy (SDH).

2 References

The following documents contain provisions which, through reference in this text, constitute provisions of the present document.

- References are either specific (identified by date of publication and/or edition number or version number) or non-specific.
- For a specific reference, subsequent revisions do not apply.
- For a non-specific reference, the latest version applies.

[1] ITU-T Recommendation G.707 (2000): "Network node interface for the synchronous digital hierarchy (SDH)".

NOTE: ITU-T Recommendation G.707 (2000) [1] contains some errors which were identified in the ITU. A corrigendum to the Recommendation [G.707 Corr.1p] [2] has been published by the ITU. Refer to annex A.

[2] ITU-T Corrigendum 1 (2001) to Recommendation G.707 [G.707 Corr.1p]

[3] ITU-T Recommendation G.702: "Digital hierarchy bit rates".

3 Definitions, abbreviations and conventions

3.1 Definitions

For the purposes of the present document, the definitions given in clause 3 of ITU-T Recommendation G.707 [1] apply.

NOTE: In ITU-T Recommendation G.707 [1], clause 3.15, the number of the information bits k is wrongly defined. Refer to annex A.

3.2 Abbreviations

For the purposes of the present document, the following abbreviations apply:

AIS	Alarm Indication Signal
APS	Automatic Protection Switching
ATM	Asynchronous Transfer Mode
AU-n	Administrative Unit-n
AUG	Administrative Unit Group
BIP-X	Bit Interleaved Parity-X
CRC-N	Cyclic Redundancy Check-N
DCC	Data Communication Channel
DQDB	Distributed Queue Dual Bus
FDDI	Fibre Distributed Data Interface
FEC	Forward Error Correction
HDLC	High-level Data Link Control
MS-RDI	Multiplex Section Remote Defect Indication
MS-REI	Multiplex Section Remote Error Indication
MSF-AIS	Multiplex Section FEC Alarm Indication Signal

NDF	New Data Flag
NNI	Network Node Interface
POH	Path OverHead
RDI	Remote Defect Indication
SDH	Synchronous Digital Hierarchy
SOH	Section OverHead
STM(-N)	Synchronous Transport Module (-N)
TU-n	Tributary Unit-n
TUG(-n)	Tributary Unit Group (-n)
VC-n	Virtual Container-n

3.3 Conventions

The order of transmission of information in all diagrams in ITU-T Recommendation G.707 [1] is first from left to right and then from top to bottom. Within each byte, the most significant bit is transmitted first. The most significant bit (bit 1) is illustrated at the left in all diagrams.

In clauses 4 to 10, the status of each requirement is given with reference to ITU-T Recommendation G.707 [1] with the following conventions:

Normative (N): Requirements with which it is necessary to comply in order to be able to claim compliance with the present document.

Not Relevant (N/R): Clause (of ITU-T Recommendation G.707 [1]) is not relevant to the present document.

The present document is not an equipment specification. The fact that a requirement is defined as normative does not imply that the associated function has to be implemented but means that, if implemented, the function shall be implemented in accordance with this requirement.

4 Basic multiplexing principles

The basic multiplexing principles are as given in clause 6 of ITU-T Recommendation G.707 [1] together with the following statements and modifications.

Table 1: Modifications and statements to clause 6 of ITU-T Recommendation G.707 [1]

Clause	Title	Statement
6	Basic Multiplexing principles	N/R
6.1	Multiplexing structure The basic SDH multiplexing structure shall be as described in figure 1. This SDH multiplexing structure is a subset of the SDH multiplexing structure defined in the clause 6.1 of ITU-T Recommendation G.707 [1]	
6.2	Basic frame structure	
6.2.1	Section overhead	N
6.2.2	Administrative Unit pointers	N
6.2.3	Administrative Units in the STM-N In this clause, reference to AU-3 is N/R	N
6.2.4	Maintenance signals	N
6.2.4.1	Alarm Indication Signals	
6.2.4.1.1	MS-AIS	N
6.2.4.1.2	MSF-AIS	
6.2.4.1.3	AU/TU-AIS	N
6.2.4.1.4	VC-AIS	N
6.2.4.2	Unequipped VC-n signal	
6.2.4.2.1	Case of network supporting the transport of Tandem Connection signals	N
6.2.4.2.2	Case of network not supporting the transport of Tandem Connection signals	N/R
6.2.4.3	Supervisory-unequipped VC-n signal	
6.2.4.3.1	Case of network supporting the transport of Tandem Connection signals	N
6.2.4.3.2	Case of network not supporting the transport of Tandem Connection signals	N/R
6.3	Hierarchical bit rates	N
6.4	Interconnection of STM-Ns	N
6.5	Scrambling (see note)	N
6.6	Physical specification of the NNI	N
NOTE:	Figures 9-2 to 9-7 of ITU-T Recommendation G.707 [1] could lead to misinterpretation of the unscrambled bytes. Refer to annex A.	

5 Multiplexing method

The multiplexing method is as given in clause 7 of ITU-T Recommendation G.707 [1] together with the following statements and modifications.

Table 2: Modifications and statements to clause 7 of ITU-T Recommendation G.707 [1]

Clause	Title	Statement
7	Multiplexing method	
7.1	Multiplexing of Administrative Units into STM-N	
7.1.1	Multiplexing of Administrative Unit Groups (AUGs) into STM-N	N
7.1.1.1	Multiplexing of AUG-N into STM-N, N=(1, 4, 16, 64, 256)	N
7.1.1.2	Multiplexing of AUG-Ns into AUG-4xN	N
7.1.2	Multiplexing of an AU-4 via AUG-1	N
7.1.3	Multiplexing of AU-3s via AUG-1	N/R
7.1.4	Multiplexing of AU-3 into STM-0	N
7.2	Multiplexing of Tributary Units into VC-4 and VC-3	
7.2.1	Multiplexing of Tributary Unit Group-3s (TUG-3s) into a VC-4	N
7.2.2	Multiplexing of a TU-3 via TUG-3	N
7.2.3	Multiplexing of TUG-2s via a TUG-3	N
7.2.4	Multiplexing of TUG-2s into a VC-3	N/R
7.2.5	Multiplexing of a TU-2 via TUG-2s	N
7.2.6	Multiplexing of TU-1s via TUG-2s	N
7.3	AU-n/TU-n numbering scheme	N
7.3.1	Numbering of AU-ns (VC-ns) in a STM-256	N
	In this clause, reference to AU-3 is N/R	
7.3.1.1	Numbering of AU-4s (VC-4s) in a STM-256	N
7.3.1.2	Numbering of AU-3s (VC-3s) in a STM-256	N/R
7.3.1.3	Numbering of AU-4-4cs (VC-4-4cs) in a STM-256	N
7.3.1.4	Numbering of AU-4-16cs (VC-4-16cs) in a STM-256	N
7.3.1.5	Numbering of AU-4-64cs (VC-4-64cs) in a STM-256	N
7.3.1.6	Numbering of an AU-4-256c in an STM-256	N
7.3.2	Numbering of AU-ns (VC-ns) in a STM-64	N
	In this clause, reference to AU-3 is N/R	
7.3.2.1	Numbering of AU-4s (VC-4s) in a STM-64	N
7.3.2.2	Numbering of AU-3s (VC-3s) in a STM-64	N/R
7.3.2.3	Numbering of AU-4-4cs (VC-4-4cs) in a STM-64	N
7.3.2.4	Numbering of AU-4-16cs (VC-4-16cs) in a STM-64	N
7.3.2.5	Numbering of an AU-4-64c in an STM-64	N
7.3.3	Numbering of AU-ns (VC-ns) in a STM-16	N
	In this clause, reference to AU-3 is N/R	
7.3.3.1	Numbering of AU-4s (VC-4s) in a STM-16	N
7.3.3.2	Numbering of AU-3s (VC-3s) in a STM-16	N/R
7.3.3.3	Numbering of AU-4-4cs (VC-4-4cs) in a STM-16	N
7.3.3.4	Numbering of AU-4-16c in an STM-16	N
7.3.4	Numbering of AU-ns (VC-ns) in a STM-4	N
	In this clause, reference to AU-3 is N/R	
7.3.4.1	Numbering of AU-4s (VC-4s) in a STM-4	N
7.3.4.2	Numbering of AU-3s (VC-3s) in a STM-4	N/R
7.3.4.3	Numbering of an AU-4-4c in an STM-4	N
7.3.5	Numbering of AU-4 (VC-4) in an STM-1 signal	N
7.3.6	Numbering of AU-3 (VC-3) in an STM-0 signal	N
7.3.7	Numbering of TU-3s in a VC-4	N
7.3.8	Numbering of TU-2s in a VC-4	N
7.3.9	Numbering of TU-12s in a VC-4	N
7.3.10	Numbering of TU-11s in a VC-4	N/R
7.3.11	Numbering of TU-2s in a VC-3	N/R
7.3.12	Numbering of TU-12s in a VC-3	N/R
7.3.13	Numbering of TU-11s in a VC-3	N/R

6 Pointers

The pointers description is as given in clause 8 of ITU-T Recommendation G.707 [1] together with the following statements and modifications.

Table 3: Modifications and statements to clause 8 of ITU-T Recommendation G.707 [1]

Clause	Title	Statement
8	Pointers	
8.1	AU-n pointer In this clause, references to AU-3 pointers are not relevant	
8.1.1	AU-n pointer location	Z
8.1.2	AU-n pointer value	Z
8.1.3	Frequency justification	Z
8.1.4	New Data Flag (NDF)	Z
8.1.5	Pointer generation	Z
8.1.6	Pointer interpretation	Z
8.1.7	AU-4 concatenation	Z
8.2	TU-3 pointer	
8.2.1	TU-3 pointer location	Z
8.2.2	TU-3 pointer value	Z
8.2.3	Frequency justification	Z
8.2.4	New Data Flag (NDF)	Z
8.2.5	Pointer generation	Z
8.2.6	Pointer interpretation	Z
8.3	TU-2/TU-1 pointer In this clause, references to TU-11 pointer are not relevant	
8.3.1	TU-2/TU-1 pointer location	Z
8.3.2	TU-2/TU-1 pointer value	Z
8.3.3	TU-2/TU-1 frequency justification	Z
8.3.4	New Data Flag (NDF)	Z
8.3.5	TU-2/TU-1 pointer generation and interpretation	Z
8.3.6	TU-2 concatenation	
8.3.7	TU-2/TU-1 sizes	Z
8.3.8	TU-2/TU-1 multiframe indication byte In this clause, reference to VC-3 is not relevant	Z

7 Overhead bytes description

The Overhead bytes description is as given in clause 9 of ITU-T Recommendation G.707 [1] together with the following statements and modifications.

Table 4: Modifications and statements to clause 9 of ITU-T Recommendation G.707 [1]

Clause	Title	Statement
9	Overhead bytes description	
9.1	Types of overhead	
9.1.1	SOH	N
9.1.2	Virtual Container POH	N
9.2	SOH description	
9.2.1	SOH bytes location	N
9.2.2	SOH bytes description	
9.2.2.1	Framing: A1, A2	N
9.2.2.2	Regenerator Section Trace: J0 In this clause, the 16-byte frame applies.	N
9.2.2.3	Spare: Z0	N
9.2.2.4	BIP-8: B1	N
9.2.2.5	Orderwire: E1, E2	N
9.2.2.6	User channel: F1	N
9.2.2.7	RS Data Communication Channel (DCCR): D1-D3	N
9.2.2.8	MS Data Communication Channel (DCCM): D4-D12	N
9.2.2.9	Extended MS Data Communication Channel (DCCMx): D13-D156	N
9.2.2.10	BIP-Nx24: B2	N
9.2.2.11	Automatic Protection Switching (APS) channel: K1, K2 (b1-b5)	N
9.2.2.12	MS-RDI: K2 (b6-b8)	N
9.2.2.13	Synchronization status: S1 (b5-b8)	N
9.2.2.14	MS-REI: M0, M1	N
9.2.2.15	Media dependant bytes	N
9.2.3	Reduced SOH functionalities interface	N
9.2.4	Forward Error Correction: P1, Q1	N
9.3	POH descriptions	
9.3.1	VC-4-Xc/VC-4/VC-3 POH	
9.3.1.1	Path trace: J1 In this clause, the 16-byte frame applies	N
9.3.1.2	Path BIP-8: B3	N
9.3.1.3	Signal label: C2	N
9.3.1.4	Path status: G1: Enhanced RDI is not supported. Consequently Bits 6 and 7 shall be set to "00" or "11" in the source direction and ignored in the sink direct.	N
9.3.1.5	Path user channels: F2, F3	N
9.3.1.6	Position and Sequence indicator: H4	N
9.3.1.7	Automatic Protection Switching (APS) channel: K3 (b1-b4)	N
9.3.1.8	Network operator byte: N1 Option 2 described in annex D of ITU-T Recommendation G.707 [1] applies	N
9.3.1.9	Data link K3 (b7-b8):	N
9.3.1.10	Spare: K3 (b5-b6)	N
9.3.2	VC-2/VC-1 POH	
9.3.2.1	V5 byte	N
9.3.2.2	Path Trace: J2	N
9.3.2.3	Network operator byte: N2	N
9.3.2.4	Extended signal label: K4 (b1)	N
9.3.2.5	Low Order Virtual Concatenation: K4 (b2)	N
9.3.2.6	Automatic Protection Switching (APS) channel: K4 (b3-b4)	N
9.3.2.7	Reserved: K4 (b5-b7): Enhanced RDI is not supported. These bits shall be set to "000" or "111" in the source direction and ignored in the sink direction	N
9.3.2.8	Data link: K4 (b8)	N
NOTE:	Regarding 9.3.2.1 (V5 byte), bit 4 of the V5 byte (RFI) of the VC-1/2 POH is not used within European countries.	

8 Mapping of tributaries into VC-n

The mapping of tributaries into VC-n is as described in clause 10 of ITU-T Recommendation G.707 [1] together with the following statements and modifications.

Table 5: Modifications and statements to clause 10 of ITU-T Recommendation G.707 [1]

Clause	Title	Statement
10	Mapping of tributaries into VC-n	
10.1	Mapping of ITU-T Recommendation G.702 [3] type signals	
10.1.1	Mapping into VC-4	
10.1.1.1	Asynchronous mapping of 139 264 kbit/s	N
10.1.2	Mapping into VC-3	
10.1.2.1	Asynchronous mapping of 44 736 kbit/s	N
10.1.2.2	Asynchronous mapping of 34 368 kbit/s	N
10.1.3	Mapping into VC-2	
10.1.3.1	Asynchronous mapping of 6 312 kbit/s	N/R
10.1.3.2	Bit synchronous mapping of 6 312 kbit/s	N/R
10.1.4	Mapping into VC-12	
10.1.4.1	Asynchronous mapping of 2 048 kbit/s	N
10.1.4.2	Byte synchronous mapping of 2 048 kbit/s	N
10.1.4.3	Byte synchronous mapping of 31 x 64 kbit/s	N
10.1.5	Mapping into VC-11	
10.1.5.1	Asynchronous mapping of 1 544 kbit/s	N
10.1.5.2	Bit synchronous mapping of 1 544 kbit/s	N/R
10.1.5.3	Byte synchronous mapping of 1 544 kbit/s	N
10.1.5.4	Byte synchronous mapping of 384 kbit/s	N
10.1.6	VC-11 to VC-12 conversion for transport by a TU-12	N
10.2	Mapping of ATM cells	
10.2.1	Mapping into VC-4-Xc/VC-4-Xv	N
10.2.2	Mapping into VC-4/VC-3	N
10.2.3	Mapping into VC-2-Xc/VC-2-Xv	N
10.2.4	Mapping into VC-2	N
10.2.5	Mapping into VC-12/VC-11	N
10.3	Mapping of HDLC framed signals	N
10.4	Mapping of DQDB into VC-4	N
10.5	Asynchronous mapping for FDDI at 125 000 kbit/s into VC-4	N

9 VC Concatenation

The mapping of tributaries into VC-n is as described in clause 11 of ITU-T Recommendation G.707 [1] together with the following statements and modifications.

Table 6: Modifications and statements to clause 11 of ITU-T Recommendation G.707 [1]

Clause	Title	Statement
11	VC Concatenation	N
11.1	Contiguous concatenation of X VC-4s (VC-4-Xc, X = 4, 16, 64, 256)	N
11.2	Virtual concatenation of X VC-3/4s (VC-3/4-Xv, X = 1 ... 256)	N
11.3	Contiguous concatenation of X VC-2s in a higher order VC-3 (VC-2-Xc, X = 1 ... 7)	N/R
11.4	Virtual concatenation of X VC-2/1s	N

10 Statements to the annexes

Forward Error Correction and Tandem Connection Monitoring are described in the annexes of ITU-T Recommendation G.707 [1] together with the following statements.

Table 7: Statements to the annexes of ITU-T Recommendation G.707 [1]

Annex	Title	Statement
A	Forward Error Correction for STM-64, and STM-256 (see note)	N
B	CRC-7 polynomial algorithm	N
C	VC-4-Xc/VC-4/VC-3 Tandem Connection Monitoring protocol: option 1	N/R
D	VC-4-Xc/VC-4/VC-3 Tandem Connection Monitoring protocol: option 2	N
E	VC-2/VC-1 Tandem Connection Monitoring protocol	N
NOTE:	Annex A of ITU-T Recommendation G.707 [1] leaves room for misinterpretation of the order of FEC and B2 processing. Refer to clauses A.1 and A.3.6	

11 Conformance testing

An SDH based interface can contain any one of a very large number of multiplexing possibilities depending upon the signals being transported over the interface. Recognizing this variety and the fact that the interface terminates on network elements, SDH equipment function standards are based on the identification of atomic functions which are then rigorously specified in terms of information flows into and out of the atomic functions.

Conformance testing is concerned with testing the functional blocks contained within a network element. Conformance testing is performed using a SDH interface(s) to exercise the functional block. Conformance testing principles will, therefore, be associated with the relevant equipment function standards.

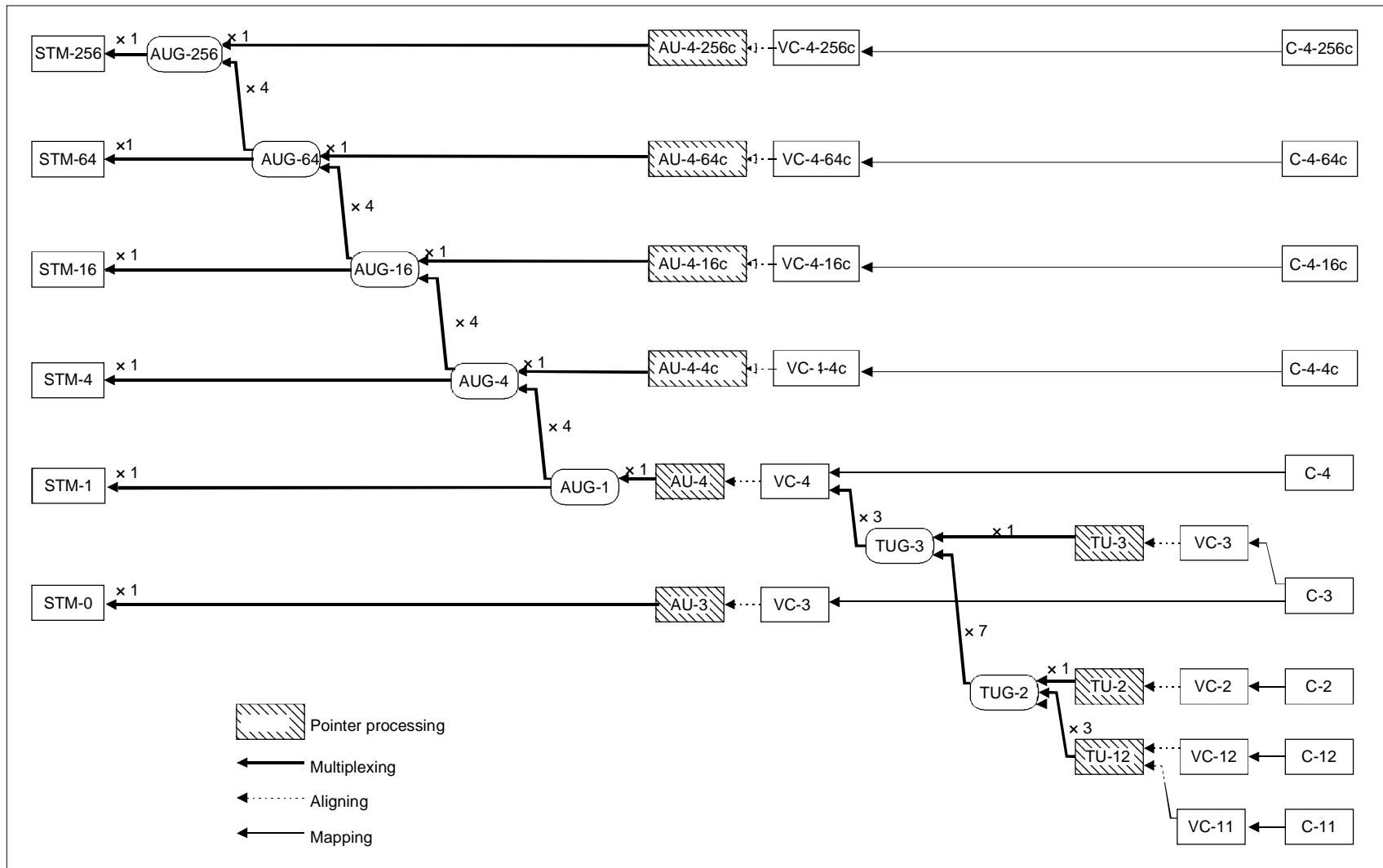

Figure 1: Multiplexing structure

Annex A (normative): G.707 corrigendum

ITU-T Recommendation G.707 [1] version contains some errors, which were discovered in the ITU. A corrigendum to the Recommendation is being developed by the ITU. Errors are identified in the description of the FEC/B2 processing and in the description of the BCH code. Probable misinterpretation of the unscrambled bytes in the section overheads result in an editorial improvement of figures 9-2 to 9-7.

ITU-T Recommendation G.707 [1], clause 3.15: shortened binary-BCH

A shortened version of the class of the block linear cyclic codes. These shortened binary BCH codes have the following common properties, i.e.

$$n = 2^m - 1 - s$$

$$k = n - t \times m$$

$$d = 2 \times t + 1$$

where:

n = the size of the whole code word;

k = the number of the information bits;

m = the parameter of the BCH code;

t = the number of the corrected errors within the block of the BCH code;

d = minimum code distance;

s = the amount of information eliminated as part of the code shorting.

ITU-T Recommendation G.707 [1], clause 9.2.1: SOH bytes location

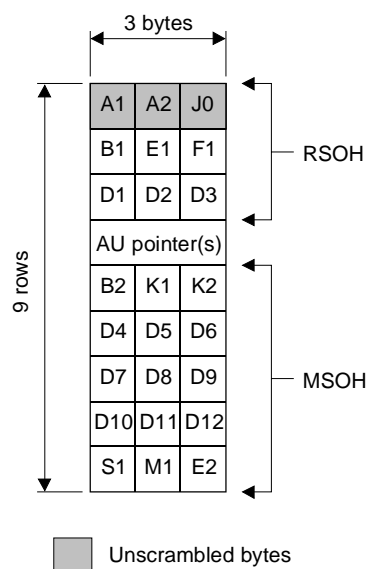

T1523130-96

Figure 9-2 of ITU-T Recommendation G.707 [1]: STM-0 SOH

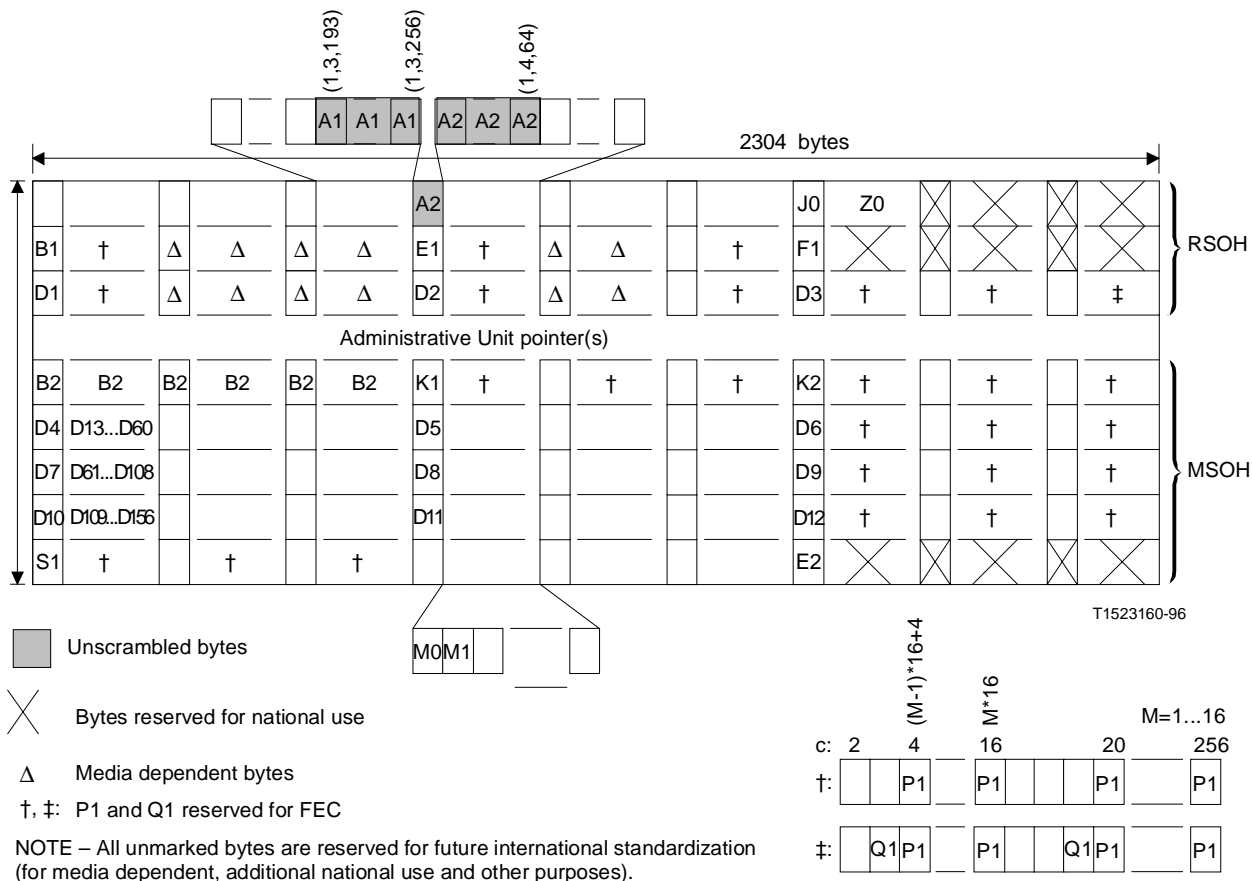

Figure 9-7 of ITU-T Recommendation G.707 [1]: STM-256 SOH

Annex A of ITU-T Recommendation G.707 [1]

Forward Error Correction for STM-64, and STM-256

ITU-T Recommendation G.707 [1], clause A.1: Network reference model

The network reference model for in-band FEC has the following characteristics:

- Conceptually, the FEC falls below the MS layer and provides a "correction service" to the MS layer. Correction at intermediate regenerators is possible.
- FEC covers and provides correction for the AUG-N area, all MSOH bytes and the FSI byte located in the RSOH.
- The FEC uses overhead bytes from the MSOH and RSOH. Regenerators have to pass-through the FEC related RSOH bytes.
- The FEC insertion function shall compensate B2 appropriately to reflect the changes in the FEC MSOH bytes. The FEC parity covers the compensated B2 bytes.
- The MS layer signal degrade and other performance monitoring functions based on B2 apply to the corrected data; they are thus appropriate for service-related performance measurements (e.g., as used for protection switching), but give no information about the raw performance of the line.
- FEC performance monitoring functions can provide information about the condition of the raw performance of the multiplex section. Use of in-band FEC performance monitoring is for further study.

ITU-T Recommendation G.707 [1], clause A 3.6: B2 Calculation at Encoder and Decoder

B2 is calculated according to clause 9.2.2.8. The FEC code bytes and FSI byte in the RSOH are not included in the B2 calculation. The FEC parity bytes in the MSOH are included in the B2 calculation. In other words, the B2 has to be **compensated** to include the FEC parity bytes accordingly in order to show the correct B2 parity.

NOTE: The FEC coding is performed over the compensated B2 parity.

The B2 bit errors are calculated after the FEC decoding based on the corrected signal and B2 bytes.

Annex B (informative): Bibliography

- ITU-T Recommendation G.704: "Synchronous frame structures used at 1 544, 6 312, 2 048, 8 488 and 44 736 kbit/s hierarchical levels".
- ITU-T Recommendation G.811: "Timing characteristics of primary reference clocks".
- ITU-T Recommendation G.831: "Management capabilities of transport networks based on the synchronous digital hierarchy (SDH)".

History

Document history		
Edition 1	March 1992	Publication
Edition 2	January 1995	Publication
Edition 3	April 1997	Publication
V1.4.1	May 2001	One-step Approval Procedure OAP 20010921: 2001-05-23 to 2001-09-21