

**Electromagnetic compatibility
and Radio spectrum Matters (ERM);
Land mobile service;
Radio equipment intended for the transmission
of data (and/or speech) using constant or non-constant
envelope modulation and having an antenna connector;
Part 1: Technical characteristics and
methods of measurement**



Reference

REN/ERM-RP02-054-1

Keywords

antenna, data, mobile, PMR, radio, speech

ETSI

650 Route des Lucioles
F-06921 Sophia Antipolis Cedex - FRANCE

Tel.: +33 4 92 94 42 00 Fax: +33 4 93 65 47 16

Siret N° 348 623 562 00017 - NAF 742 C
Association à but non lucratif enregistrée à la
Sous-Préfecture de Grasse (06) N° 7803/88

Important notice

Individual copies of the present document can be downloaded from:

<http://www.etsi.org>

The present document may be made available in more than one electronic version or in print. In any case of existing or perceived difference in contents between such versions, the reference version is the Portable Document Format (PDF). In case of dispute, the reference shall be the printing on ETSI printers of the PDF version kept on a specific network drive within ETSI Secretariat.

Users of the present document should be aware that the document may be subject to revision or change of status. Information on the current status of this and other ETSI documents is available at

<http://portal.etsi.org/tb/status/status.asp>

If you find errors in the present document, send your comment to:

editor@etsi.fr

Copyright Notification

No part may be reproduced except as authorized by written permission.
The copyright and the foregoing restriction extend to reproduction in all media.

© European Telecommunications Standards Institute 2001.
All rights reserved.

Contents

Intellectual Property Rights	8
Foreword.....	8
Introduction	8
1 Scope	10
2 References	11
3 Definitions, symbols and abbreviations	11
3.1 Definitions	11
3.2 Symbols.....	12
3.3 Abbreviations	13
4 General	13
4.1 Selection of equipment for testing purposes	14
4.2 Mechanical and electrical design.....	14
4.2.1 General.....	14
4.2.2 Controls	14
4.2.3 Transmitter shut-off facility.....	15
4.2.4 Marking	15
4.3 Interpretation of the measurement results	15
4.4 Testing using bit streams or messages.....	15
5 Technical characteristics	15
5.1 Transmitter parameter limits	15
5.1.1 Frequency error.....	15
5.1.2 Carrier power (conducted).....	16
5.1.3 Effective radiated power	16
5.1.4 Adjacent channel power.....	17
5.1.5 Spurious emissions	17
5.1.6 Intermodulation attenuation.....	18
5.1.7 Transmitter attack time	18
5.1.8 Transmitter release time.....	18
5.1.9 Transient behaviour of the transmitter.....	18
5.1.9.1 Time domain analysis of power and frequency.....	19
5.1.9.2 Adjacent channel transient power	19
5.1.9.2.1 Equipment measured as constant envelope angle modulation equipment	19
5.1.9.2.2 Equipment measured as non-constant envelope modulation equipment	19
5.2 Receiver parameter limits.....	20
5.2.1 Maximum usable sensitivity (data or messages, conducted)	20
5.2.2 Average usable sensitivity (data or messages, field strength).....	20
5.2.3 Error behaviour at high input levels.....	20
5.2.4 Co-channel rejection	20
5.2.5 Adjacent channel selectivity	21
5.2.6 Spurious response rejection	21
5.2.7 Intermodulation response rejection.....	21
5.2.8 Blocking or desensitization.....	21
5.2.9 Spurious radiations	21
5.3 Duplex operation - receiver limits.....	22
5.3.1 Receiver desensitization and maximum usable sensitivity (with simultaneous transmission and reception).....	22
5.3.2 Receiver spurious response rejection (with simultaneous transmission and reception).....	22
6 Test conditions, power sources and ambient temperatures	22
6.1 Normal and extreme test conditions	22
6.2 Test power source.....	22
6.3 Normal test conditions.....	23
6.3.1 Normal temperature and humidity	23

6.3.2	Normal test power source	23
6.3.2.1	Mains voltage	23
6.3.2.2	Regulated lead-acid battery power sources used on vehicles	23
6.3.2.3	Other power sources	23
6.4	Extreme test conditions	23
6.4.1	Extreme temperatures	23
6.4.2	Extreme test source voltages	23
6.4.2.1	Mains voltage	23
6.4.2.2	Regulated lead-acid battery power sources on vehicles	24
6.4.2.3	Power sources using other types of batteries	24
6.4.2.4	Other power sources	24
6.5	Procedure for tests at extreme temperatures	24
6.5.1	Procedure for equipment designed for continuous operation	24
6.5.2	Procedure for equipment designed for intermittent operation	25
7	General conditions	25
7.1	Arrangements for test signals applied to the receiver input	25
7.2	Receiver mute or squelch facility	25
7.3	Normal test signals (wanted and unwanted signals)	25
7.3.1	Equipment measured as constant envelope angle modulation equipment	25
7.3.2	Equipment measured as non constant envelope modulation equipment	26
7.4	Encoder for receiver measurements	27
7.5	Transceiver data interface	27
7.6	Impedance	27
7.7	Artificial antenna	27
7.8	Tests of equipment with a duplex filter	27
7.9	Facilities for access	27
7.9.1	Analogue access	27
7.9.2	Test points for bit stream measurements	28
7.9.3	Coupling arrangements	28
7.9.3.1	Arrangements for measurements with continuous bit streams	28
7.9.3.2	Arrangements for measurements with messages	28
7.10	Test site and general arrangements for measurements involving the use of radiated fields	28
7.11	Modes of operation of the transmitter	29
8	Methods of measurement for transmitter parameters	29
8.1	Frequency error	29
8.1.1	Definition	29
8.1.2	Method of measurement	29
8.2	Carrier power (conducted)	30
8.2.1	Definitions	30
8.2.1.1	Equipment measured as constant envelope angle modulation equipment	30
8.2.1.2	Equipment measured as non-constant envelope modulation equipment	30
8.2.2	Method of measurement	30
8.2.2.1	Equipment measured as constant envelope angle modulation equipment	30
8.2.2.2	Equipment measured as non-constant envelope modulation equipment	30
8.3	Effective radiated power (field strength)	31
8.3.1	Definition	31
8.3.1.1	Equipment measured as constant envelope angle modulation equipment	31
8.3.1.2	Equipment measured as non-constant envelope modulation equipment	31
8.3.2	Methods of measurement	32
8.3.2.1	Equipment measured as constant envelope angle modulation equipment	33
8.3.2.2	Equipment measured as non-constant envelope modulation equipment	34
8.4	Maximum permissible frequency deviation	35
8.4.1	Definition	35
8.4.2	Method of measurement	35
8.5	Adjacent channel power	36
8.5.1	Definition	36
8.5.2	Method of measurement	36
8.6	Spurious emissions	37
8.6.1	Definition	37
8.6.2	Method of measuring the power level	37

8.6.2.1	Equipment measured as constant envelope angle modulation equipment.....	38
8.6.2.2	Equipment measured as non-constant envelope modulation equipment.....	38
8.6.3	Method of measuring the effective radiated power.....	39
8.6.3.1	Equipment measured as constant envelope angle modulation equipment.....	39
8.6.3.2	Equipment measured as non-constant envelope modulation equipment.....	40
8.7	Intermodulation attenuation.....	41
8.7.1	Definition.....	41
8.7.2	Method of measurement	42
8.8	Transmitter attack time.....	42
8.8.1	Definition.....	43
8.8.2	Method of measurement	43
8.9	Transmitter release time	43
8.9.1	Definition.....	43
8.9.2	Method of measurement	44
8.10	Transient behaviour of the transmitter.....	44
8.10.1	Definitions	44
8.10.2	Timings, frequencies and powers	45
8.10.3	Methods of measurement.....	49
8.10.3.1	Time domain measurements of power and frequency.....	49
8.10.3.2	Test arrangement and characteristics of the test discriminator.....	50
8.10.3.3	Adjacent channel transient power measurements.....	50
8.10.3.3.1	Definition.....	50
8.10.3.3.2	Equipment measured as constant envelope angle modulation equipment.....	50
8.10.3.3.3	Equipment measured as non-constant envelope modulation equipment	51
8.10.3.4	Characteristics of the adjacent channel transient power measuring device.....	52
9	Methods of measurement for receiver parameters	52
9.1	Maximum usable sensitivity (data or messages, conducted).....	52
9.1.1	Definition.....	52
9.1.2	Method of measurement with continuous bit streams.....	53
9.1.3	Method of measurement with messages	53
9.2	Average usable sensitivity (data or messages, field strength)	54
9.3	Level of the wanted signal for the degradation measurements (data or messages)	54
9.4	Error behaviour at high input levels	54
9.4.1	Definition.....	54
9.4.2	Method of measurement with continuous bit streams.....	55
9.4.3	Method of measurement with messages	55
9.5	Co-channel rejection.....	56
9.5.1	Definition.....	56
9.5.2	Method of measurement with continuous bit streams.....	56
9.5.3	Method of measurement with messages	57
9.6	Adjacent channel selectivity.....	58
9.6.1	Definition.....	58
9.6.2	Method of measurement with continuous bit streams.....	58
9.6.3	Method of measurement with messages	59
9.7	Spurious response rejection.....	60
9.7.1	Definition.....	60
9.7.2	Introduction to the method of measurement	61
9.7.3	Method of search over the "limited frequency range"	61
9.7.4	Method of measurement with continuous bit streams.....	62
9.7.5	Method of measurement with messages	63
9.8	Intermodulation response rejection	64
9.8.1	Definition.....	64
9.8.2	Method of measurement with continuous bit streams.....	64
9.8.3	Method of measurement with messages	65
9.9	Blocking or desensitization	66
9.9.1	Definition.....	66
9.9.2	Method of measurement with continuous bit streams.....	66
9.9.3	Method of measurement with messages	67
9.10	Spurious radiations	68
9.10.1	Definition.....	68
9.10.2	Method of measuring the power level	69

9.10.3	Method of measuring the effective radiated power.....	69
10	Duplex operation	71
10.1	Receiver desensitization (with simultaneous transmission and reception).....	71
10.1.1	Definition.....	71
10.1.2	Desensitization measured with continuous bit streams.....	71
10.1.2.1	Method of measurement when the equipment has a duplex filter.....	71
10.1.2.2	Method of measurement when the equipment has to operate with two antennas.....	72
10.1.3	Desensitization measured with messages	73
10.1.3.1	Method of measurement when the equipment has a duplex filter	73
10.1.3.2	Method of measurement when the equipment has to operate with two antennas.....	74
10.2	Receiver spurious response rejection (with simultaneous transmission and reception)	75
10.2.1	Definition.....	75
10.2.2	Method of measurement	75
11	Measurement uncertainty	76
Annex A (normative): Radiated measurement.....		77
A.1	Test sites and general arrangements for measurements involving the use of radiated fields	77
A.1.1	Anechoic Chamber	77
A.1.2	Anechoic Chamber with a conductive ground plane	78
A.1.3	Open Area Test Site (OATS)	79
A.1.4	Test antenna.....	80
A.1.5	Substitution antenna	81
A.1.6	Measuring antenna	81
A.2	Guidance on the use of radiation test sites	81
A.2.1	Verification of the test site	81
A.2.2	Preparation of the EUT.....	81
A.2.3	Power supplies to the EUT	81
A.2.4	Volume control setting for analogue speech tests	82
A.2.5	Range length.....	82
A.2.6	Site preparation	82
A.3	Coupling of signals.....	83
A.3.1	General	83
A.3.2	Data Signals.....	83
A.3.3	Speech and analogue signals	83
A.3.3.1	Acoustic coupler description.....	83
A.3.3.2	Calibration	84
Annex B (normative): Specification for some particular measurement arrangements.....		85
B.1	Power measuring receiver specification.....	85
B.1.1	IF filter	85
B.1.2	Attenuation indicator.....	86
B.1.3	rms value indicator	86
B.1.4	Oscillator and amplifier.....	86
B.2	Spectrum analyser specification.....	87
B.3	Integrating and power summing device	87
Annex C (normative): Identification		88
C.1	Scope	88
C.2	General	88
C.3	Position of the identification code.....	89
C.3.1	Base stations.....	89
C.3.1.1	System without windows	89
C.3.1.2	Systems with windows.....	89
C.3.2	Mobile stations	89
C.4	Bit rates and modulations	90

C.5	Format of the identification.....	91
C.6	Synchronization.....	91
C.7	Code and block length.....	92
C.8	Contents of the identification block	92
C.8.1	Header	92
C.8.2	Country/regional code	93
C.8.3	National Information	94
C.8.3.1	Field description	94
C.8.3.2	Field size options	94
C.8.3.3	Options for the organization of the fields	94
C.8.3.4	Examples of user/system information usage.....	95
C.9	Combinations	96
C.9.1	List of possible combinations.....	96
C.9.2	Relations between country/regional code and allowed combinations	96
C.9.3	Interpretation of the fields of the ID block.....	97
Annex D (normative):	Graphical representation of the selection of equipment and frequencies for testing	98
D.1	Tests on a single sample.....	98
D.2	Tests and samples needed when the switching range is a subset of the alignment range	99
D.3	Tests and samples for a family of equipment where the alignment range is a subset of the total operating frequency range	100
D.3.1	Test scenario 1.....	100
D.3.2	Test scenario 2.....	100
Annex E (informative):	Information on modulation, coding and format	102
Annex F (informative):	Bibliography.....	103
History		104

Intellectual Property Rights

IPRs essential or potentially essential to the present document may have been declared to ETSI. The information pertaining to these essential IPRs, if any, is publicly available for **ETSI members and non-members**, and can be found in ETSI SR 000 314: "*Intellectual Property Rights (IPRs); Essential, or potentially Essential, IPRs notified to ETSI in respect of ETSI standards*", which is available from the ETSI Secretariat. Latest updates are available on the ETSI Web server (<http://webapp.etsi.org/IPR/home.asp>).

Pursuant to the ETSI IPR Policy, no investigation, including IPR searches, has been carried out by ETSI. No guarantee can be given as to the existence of other IPRs not referenced in ETSI SR 000 314 (or the updates on the ETSI Web server) which are, or may be, or may become, essential to the present document.

Foreword

This European Standard (Telecommunications series) has been produced by ETSI Technical Committee Electromagnetic compatibility and Radio spectrum Matters (ERM), and is now submitted for the Vote phase of the ETSI standards Two-step Approval Procedure.

The present document was previously submitted to V20010125 and due to technical errors was withdrawn.

The present document is part 1 of a multi-part deliverable covering the Electromagnetic compatibility and Radio spectrum Matters (ERM); Land mobile service; Radio equipment intended for the transmission of data (and/or speech) using constant or non-constant envelope modulation and having an antenna connector, as identified below:

Part 1: "Technical characteristics and methods of measurement";

Part 2: "Harmonized EN covering essential requirements under article 3.2 of the R&TTE Directive".

Proposed national transposition dates	
Date of latest announcement of this EN (doa):	3 months after ETSI publication
Date of latest publication of new National Standard or endorsement of this EN (dop/e):	6 months after doa
Date of withdrawal of any conflicting National Standard (dow):	6 months after doa

Introduction

The present document is intended to specify the minimum performance and the methods of measurement of radio equipment for use in the land mobile service as specified in the scope.

The present document is based upon EN 300 113-1 (version 1.3.1) [10].

EN 300 113-1 (version 1.3.1) [10] covered only constant envelope angle modulation equipment. The present document covers both constant envelope angle modulation and non-constant envelope modulation equipment as described in the scope.

This is a general standard which may be overridden or complemented by specific standards addressing specific applications. It applies to equipment designed to operate within the professional mobile radio service and to the associated frequency planning.

Equipment similar to that covered by the present document, but using constant envelope modulation only (at the time of publication of present document) and having an integral antenna is covered by EN 300 390 [2] (for details, see the scope of the present document as well as the scope of EN 300 390 [2]).

Access protocols for equipment covered by the present document are the subject of other ETSI standards such as EN 300 471-1 [11].

Channel separations, maximum transmitter output power/effective radiated power, class of transmitter intermodulation attenuation and the inclusion of automatic transmitter shut-off facility may all be conditions relating to the issue of a licence by the appropriate administration.

- Annex A: is normative and provides additional information concerning radiated measurements.
- Annex B: is normative and gives the requirements for equipment to be used for the measurements of adjacent channel power.
- Annex C: is normative and presents the technical characteristics to be fulfilled, when required by the appropriate national regulatory authority, for the identification of stations for professional mobile radio systems, that do not comply with other system protocols (e.g. trunking protocols); it is the responsibility of the manufacturer to ensure that the modulation that he has chosen for the identification, in accordance with the tables of this annex fulfils the requirements corresponding to the channels where the equipment is designed to operate, as specified in the main body of the present document. The tables of this annex are expected to be updated regularly in order to reflect the progress accomplished in the field of mobile data transmissions.
- Annex D: is informative and gives a graphic representation corresponding to the selection of equipment for testing purposes (it is based on EN 300 793 [3]).
- Annex E: is informative and provides guidance concerning the technical characteristics of the modulation, coding and format.

Clause 5 provides the appropriate limits. These limits have been chosen to ensure an acceptable grade of service and to minimize harmful interference to other equipment and services. They are based on the interpretation of the measurement results described in clause 4.3.

Provision for the placing on the market of radio equipment in EU Member States can be found in the R&TTE Directive (Directive 1999/5/EC). It can also be noted that some of the parameters considered as essential under the R&TTE Directive had already been listed as essential under the EMC Directive.

The present document may also be used in CEPT Countries that are not EU Member States. For the benefit of these Countries, mechanisms for mutual recognition of type approval have been identified in CEPT/ERC/DEC(97)10.

Alternatively, another approach may be used in Countries that have not implemented this Decision: type test measurements performed in an accredited test laboratory in one country would be accepted by the Administration in another country provided that the national regulatory requirements are met (CEPT/ERC/REC 01-06).

Decision CEPT/ERC/DEC(97)10 also addresses issues related to total quality management.

The present document may, in particular, be used by accredited test laboratories for the assessment of the performance of the equipment. The performance of the equipment, in the case of conformity assessment measurements, shall be representative for the performance of the corresponding production model. In order to avoid any ambiguity in that assessment, the present document contains general instructions (clause 4), conditions (clauses 6 and 7) and methods of measurement (clauses 8, 9 and 10).

The present document was drafted on the assumption that if equipment available on the market is required to be checked, it should be tested in accordance with the methods of measurement specified in the present document.

1 Scope

The present document covers the minimum characteristics considered necessary in order to avoid harmful interference and to make acceptable use of the available frequencies. It does not necessarily include all the characteristics which may be required by a user, nor does it necessarily represent the optimum performance achievable.

The present document applies to either constant envelope angle modulation systems or to non-constant envelope modulation systems for use in the land mobile service, operating on radio frequencies between 30 MHz and 1 GHz, with channel separations of 12,5 kHz, 20 kHz and 25 kHz, intended for data transmissions. It applies to digital and combined analogue and digital radio equipment with an internal or external antenna connector intended for the transmission of data and/or speech.

The particular type of modulation will be chosen by the manufacturer, although it is recognized that in some countries national legislation may limit the use of certain code structures/data formats.

The technical characteristics given in the present document are independent of data rate but may in practice limit the maximum data rate achievable.

In the present document different requirements are given for the different radio frequency bands, channel separations, etc. where appropriate.

In the present document, data transmission systems are defined as systems which transmit and/or receive data. The equipment comprises a transmitter and associated encoder and modulator and/or a receiver and associated demodulator and decoder.

The types of equipment covered by the present document are as follows:

- base station (equipment fitted with an antenna socket, intended for use in a fixed location);
- mobile station (equipment fitted with an antenna socket, normally used in a vehicle or as a transportable);
- and those hand portable stations:
 - a) fitted with an antenna socket; or
 - b) without an external antenna socket (integral antenna equipment), but fitted with a permanent internal or a temporary internal 50 Ω Radio Frequency (RF) connector which allows access to the transmitter output and the receiver input.

Hand portable equipment without an external or internal RF connector and without the possibility of having a temporary internal 50 Ω RF connector is not covered by the present document (integral antenna equipment is covered by EN 300 390 [2] for details, see the corresponding scope).

Additional standards or specifications may also be required for equipment such as that intended for connection to the Public Switched Telephone Network (PSTN), or data networks.

Requirements to be fulfilled by equipment designed to meet several standards can be found in clause 4.

2 References

The following documents contain provisions which, through reference in this text, constitute provisions of the present document.

- References are either specific (identified by date of publication and/or edition number or version number) or non-specific.
- For a specific reference, subsequent revisions do not apply.
- For a non-specific reference, the latest version applies.

- [1] ETSI EN 300 086 (all parts): "Electromagnetic compatibility and Radio spectrum Matters (ERM); Land Mobile Service; Radio equipment with an internal or external RF connector intended primarily for analogue speech".
- [2] ETSI EN 300 390 (all parts): "Electromagnetic compatibility and Radio spectrum Matters (ERM); Land Mobile Service; Radio equipment intended for the transmission of data (and speech) and using an integral antenna".
- [3] ETSI EN 300 793: "Electromagnetic compatibility and Radio spectrum Matters (ERM); Land mobile service; Presentation of equipment for type testing".
- [4] ETSI TR 100 028 (all parts): "Electromagnetic compatibility and Radio spectrum Matters (ERM); Uncertainties in the measurement of mobile radio equipment characteristics".
- [5] ETSI ETR 273 (all parts): "Electromagnetic compatibility and Radio spectrum Matters (ERM); Improvement of radiated methods of measurement (using test sites) and evaluation of the corresponding measurement uncertainties".
- [6] ITU-T Recommendation O.153: "Basic parameters for the measurement of error performance at bit rates below the primary rate".
- [7] ANSI/IEEE C63.5 (1998): "American National Standard for Electromagnetic Compatibility - Radiated Emission Measurements in Electro Magnetic Interference (EMI) Control - Calibration of Antennas (9 kHz to 40 GHz)".
- [8] IEC 60489-3 (1988): "Methods of measurement for radio equipment used in the mobile services. Part 3: Receivers for A3E or F3E emissions".
- [9] CEPT/ERC/REC 74-01E (Siófok 1998, Nice 1999): "Spurious emissions".
- [10] ETSI EN 300 113-1 (V1.3.1): "Electromagnetic compatibility and Radio spectrum Matters (ERM); Land mobile service; Radio equipment intended for the transmission of data (and speech) and having an antenna connector; Part 1: Technical characteristics and methods of measurement".
- [11] ETSI EN 300 471-1: "Electromagnetic compatibility and Radio spectrum Matters (ERM); Land Mobile Service; Rules for Access and the Sharing of common used channels by equipment complying with EN 300 113; Part 1: Technical characteristics and methods of measurement".

3 Definitions, symbols and abbreviations

3.1 Definitions

For the purposes of the present document, the following terms and definitions apply:

base station: equipment fitted with an antenna socket, for use with an external antenna, and intended for use in a fixed location

mobile station: mobile equipment fitted with an antenna socket, for use with an external antenna, normally used in a vehicle or as a transportable station

hand portable station: equipment either fitted with an antenna socket or integral antenna, or both, normally used on a stand-alone basis, to be carried on a person or held in the hand

integral antenna: antenna designed to be connected to the equipment without the use of a 50 Ω external connector and considered to be part of the equipment

NOTE: An integral antenna may be fitted internally or externally to the equipment.

angle modulation: either phase modulation or frequency modulation

full tests: All tests are defined in EN 300 113-1.

limited tests: limited tests, as defined in EN 300 793 [3], are as follows:

- transmitter frequency error, clause 8.1;
- transmitter carrier power (conducted), clause 8.2;
- transmitter effective radiated power, clause 8.3, integral antenna equipment only;
- transmitter adjacent channel power, clause 8.5;
- receiver maximum usable sensitivity (conducted): clause 9.1;
- receiver average usable sensitivity (field strength), clause 9.2, integral antenna equipment only;
- receiver adjacent channel selectivity, clause 9.6.

conducted measurements: measurements which are made using direct 50 Ω connection to the equipment under test

radiated measurements: measurements which involve the absolute measurement of a radiated field

bit: binary digit

block: smallest quantity of information that is sent over the radio channel

NOTE: A constant number of useful bits are always sent together with the corresponding redundancy bits.

packet: one block or a contiguous stream of blocks sent by one (logical) transmitter to one particular receiver or one particular group of receivers

transmission (physical): one or several packets transmitted between power on and power off of a particular transmitter

window: set of inter-related transmissions which may be limited in time by an appropriate access protocol and corresponding occupation rules

session: set of inter-related exchange of packets occupying one or several windows or part thereof (if applicable)

NOTE: It corresponds to a complete interactive procedure for interchanging data between users, comprising initiation, data transmission and termination procedures. The session can be short (e.g. 2 packets), or long (e.g. one full page of text).

message: user data to be transferred in one or more packets in a session

3.2 Symbols

For the purposes of the present document, the following symbols apply:

E _o	reference field strength
R _o	reference distance
dBd	antenna gain relative to $\lambda/2$ dipole (clause A.1.3)
dBi	antenna gain relative to an isotropic radiator (clause A.1.3)
D-M0, D-M1...	names of signals defined in clause 7.3

The symbols used in the clauses relating to transients and timings can be found in clause 8.10.1.

3.3 Abbreviations

For the purposes of the present document, the following abbreviations apply:

AR1, AR2	Categories of "alignment range" as defined in clause 4.1
BS	Base Station
CRC	Cyclic Redundancy Code
CSP	Channel Separation
CW	Continuous Wave
dBc	decibels relative to the carrier power
emf	electromotive force
FEC	Forward Error Correction
FFSK	Fast Frequency Shift Keying
FSK	Frequency Shift Keying
GMSK	Gaussian Minimum Shift Keying
IF	Intermediate Frequency
LSB	Least Significant Bit
MSB	Most Significant Bit
MSK	Minimum Shift Keying
OQAM	Offset Quadrature Amplitude Modulation
OQPSK	Offset Quaternary Phase Shift Keying
PEP	Peak Envelope Power
PLL	Phase Locked Loop
PSK	Phase Shift Keying
PSTN	Public Switched Telephone Network
QAM	Quadrature Amplitude Modulation
RF	Radio Frequency
rms	root mean square
sr	switching range
Tx	Transmitter

4 General

Equipment may be designed to fulfil the requirements of one or more standards.

In the case of combined full bandwidth analogue speech/full bandwidth digital equipment, if the analogue part of the equipment has already been measured according to EN 300 086 [1], only some additional measurements have to be performed; they shall ensure that the equipment fulfils the requirements of the following clauses:

- 5.1.4 (8.5) Adjacent channel power;
- 5.1.5 (8.6) Spurious emissions;
- 5.1.7 (8.8) Transmitter attack time;
- 5.1.8 (8.9) Transmitter release time;
- 5.1.9 (8.10) Transient behaviour of the transmitter;
- 5.2.1 (9.1) Maximum usable sensitivity (data or messages, conducted);
- 5.2.2 (9.2) Average usable sensitivity (data or messages, field strength) in the case of equipment having an integral antenna;
- 5.2.3 (9.4) Error behaviour at high input levels;
- 5.2.4 (9.5) Co-channel rejection;
- 5.2.5 (9.6) Adjacent channel selectivity.

More precisely, the measurement of the spurious emissions (clauses 5.1.5 and 8.6) should be performed when an equipment, previously measured to EN 300 086 [1], is being measured to the present document with an add-on data unit. If the equipment has been originally combined for analogue and digital operation, the measurement of the spurious emissions need not to be performed again if the data port(s) (and the data circuits/modules) were active while making this measurement for the test to EN 300 086 [1].

In the case where an equipment has already been measured according to the present document and is to be measured again with an add-on data unit using another type of modulation without affecting any other characteristic of the equipment, only some additional measurements should be performed; they shall ensure that the equipment fulfils the requirements of the following clauses:

- 5.1.4 (8.5) Adjacent channel power;
- 5.1.5 (8.6) Spurious emissions;
- 5.2.1 (9.1) Maximum usable sensitivity (data or messages, conducted);
- 5.2.2 (9.2) Average usable sensitivity (data or messages, field strength) in the case of equipment having an integral antenna;
- 5.2.3 (9.4) Error behaviour at high input levels;
- 5.2.4 (9.5) Co-channel rejection;
- 5.2.5 (9.6) Adjacent channel selectivity.

The foregoing seven measurements shall be performed on one piece of equipment tuned to a frequency in the centre of the band.

In the case where data is transmitted simultaneously together with analogue speech, the speech part of the equipment is tested according to EN 300 086 [1], and it shall also be checked that the data does not cause the adjacent channel power and spurious emissions to fall outside the appropriate limits.

Constant envelope angle modulation systems can be measured following the measurement procedure either for constant envelope angle modulation equipment or for non-constant envelope modulation equipment.

Non-constant envelope modulation systems shall always be measured following the measurement procedure for non-constant envelope modulation equipment.

In both cases, the type of measurement procedure used shall be reported in the test report.

4.1 Selection of equipment for testing purposes

For information regarding the selection of equipment for testing purposes, refer to EN 300 793 [3].

It is expected that the usage of similar measurement methodologies will make it more likely that different laboratories measuring the same equipment get comparable measurement results.

4.2 Mechanical and electrical design

4.2.1 General

The equipment shall be designed, constructed and manufactured in accordance with good engineering practice, and with the aim of minimizing harmful interference to other equipment and services.

4.2.2 Controls

Those controls, which if maladjusted, might increase the interfering potentialities of the equipment shall not be accessible for adjustment by the user.

4.2.3 Transmitter shut-off facility

When a timer for an automatic shut-off facility is operative, at the moment of the time-out the transmitter shall automatically be switched off (the re-activation of the transmitter shall reset the timer).

A shut-off facility shall be inoperative for the duration of the measurements unless it has to remain operative to protect the equipment. If the shut off facility is left operative the status of the equipment shall be indicated.

4.2.4 Marking

The equipment shall be marked in a visible place. This marking shall be legible, tamperproof and durable.

The marking shall be in accordance with EC Directives and/or CEPT decisions or recommendations as appropriate.

4.3 Interpretation of the measurement results

The interpretation of the results (e.g. results recorded in a test report) for the measurements described in the present document shall be as follows:

- a) the measured value related to the corresponding limit shall be used to decide whether an equipment meets the requirements for that parameter of the present document;
- b1) the value of the actual measurement uncertainty shall be, for each measurement, equal to or lower than the figures given in clause 11 (maximum acceptable values of the measurement uncertainties);
- b2) the actual measurement uncertainty of the laboratory carrying out the measurements, for each particular measurement, shall be included in the corresponding test report (if any).

For the test methods, according to the present document, the measurement uncertainty figures shall be calculated in accordance with TR 100 028 [4] and shall correspond to an expansion factor (coverage factor) $k = 1,96$ or $k = 2$ (which provide confidence levels of respectively 95 % and 95,45 % in the case where the distributions characterizing the actual measurement uncertainties are normal (Gaussian)).

The particular expansion factor used for the evaluation of the measurement uncertainty shall be stated.

4.4 Testing using bit streams or messages

The manufacturer may elect to have the equipment tested using bit streams or messages. It should be noted that the methods of measurement using messages are usually more time consuming.

5 Technical characteristics

This clause contains the limit values of the parameters defined in clauses 8 to 10.

5.1 Transmitter parameter limits

5.1.1 Frequency error

For the definition and the method of measurement, see clause 8.1.

The frequency error shall not exceed the values given in table 1, under normal and extreme test conditions, or in any intermediate set of conditions. However, for practical reasons the measurement shall be performed only at nominal and extreme test conditions as defined in clause 8.1.

Table 1: Frequency error

Channel separation (kHz)	Frequency error limit (kHz)				
	below 47 MHz	47 MHz to 137 MHz	above 137 MHz to 300 MHz	above 300 MHz to 500 MHz	above 500 MHz to 1 000 MHz
20 & 25	±0,60	±1,35	±2,00	±2,00 (note)	±2,50 (note)
12,5	±0,60	±1,00	±1,00 (B) ±1,50 (M)	±1,00 (B) ±1,50 (M) (note)	No value specified

NOTE: For hand portable stations having integral power supplies, these limits only apply to the reduced extreme temperature range 0°C to +30°C.
However for the full extreme temperature conditions (clause 6.4.1), exceeding the reduced extreme temperature range above, the following frequency error limits apply:

- ±2,50 kHz between 300 MHz and 500 MHz;
- ±3,00 kHz between 500 MHz and 1 000 MHz.

(B) base station.
(M) mobile station.

5.1.2 Carrier power (conducted)

This measurement applies to all equipment covered by the present document.

For the definition and the method of measurement, see clause 8.2.

The carrier power (conducted) under the specified conditions of measurement (clause 8.2.2) and at normal test conditions, shall be within ±1,5 dB of the rated carrier power (conducted).

The carrier power (conducted) under extreme test conditions shall be within +2,0 dB and -3,0 dB of the rated output power.

5.1.3 Effective radiated power

This measurement applies only to equipment without a 50 Ω external antenna connector.

For the definition and the method of measurement, see clause 8.3.

The measurement shall be carried out under normal test conditions only.

The effective radiated power under normal test conditions shall be within d_f from the rated effective radiated power.

The allowance for the characteristics of the equipment (±1,5 dB) shall be combined with the actual measurement uncertainty in order to provide d_f , as follows:

$$d_f^2 = d_m^2 + d_e^2$$

where:

- d_m is the actual measurement uncertainty;
- d_e is the allowance for the equipment (1,5 dB);
- d_f is the final difference.

All values shall be expressed in linear terms.

In all cases the actual measurement uncertainty shall comply with clause 11.

Furthermore, the maximum effective radiated power shall not exceed the maximum value allowed by the Administrations.

Example of the calculation of d_f :

- $d_m = 6$ dB (value acceptable, as indicated in the table of maximum uncertainties);
- $d_m = 3,98$ in linear terms;
- $d_e = 1,5$ dB (fixed value for all equipment fulfilling the requirements of the present document);
- $d_e = 1,41$ in linear terms;
- $df^2 = (3,98)^2 + (1,41)^2$;

Therefore, $d_f = 4,22$ in linear terms, or 6,25 dB.

This calculation shows that in this case d_f is in excess by 0,25 dB compared to d_m , the actual measurement uncertainty (6 dB).

5.1.4 Adjacent channel power

For the definition and the method of measurement, see clause 8.5.

For channel separations of 20 kHz and 25 kHz, the adjacent channel power shall not exceed a value of 70,0 dB below the carrier power (conducted) of the transmitter without any need to be below 0,2 μ W (-37 dBm).

For a channel separation of 12,5 kHz, the adjacent channel power shall not exceed a value of 60,0 dB below the transmitter carrier power (conducted) without the need to be below 0,2 μ W (-37 dBm).

5.1.5 Spurious emissions

For the definition and the method of measurement, see clause 8.6.

The power of any spurious emission shall not exceed the values given in tables 2 and 3.

Table 2: Conducted emissions

Frequency range	Tx operating	Tx standby
9 kHz to 1 GHz	0,25 μ W (-36 dBm)	2,0 nW (-57 dBm)
above 1 GHz to 4 GHz, or above 1 GHz to 12,75 GHz (clause 8.6.2)	1,00 μ W (-30 dBm)	20 nW (-47 dBm)

Table 3 a): Radiated emissions

Frequency range	Tx operating	Tx standby
30 MHz to 1 GHz	0,25 μ W (-36 dBm)	2,0 nW (-57 dBm)
above 1 GHz to 4 GHz	1,00 μ W (-30 dBm)	20 nW (-47 dBm)

In the case of radiated measurements for hand portable stations the following conditions apply:

- for equipment with an internal integral antenna, the normal antenna shall remain connected;
- for equipment with an external antenna socket, an artificial load shall be connected to the socket for the test.

In the case of equipment measured as non-constant envelope modulation equipment, the reference bandwidths used in clause 8.6 shall be as stated in the table 3 b):

Table 3 b): Reference bandwidths to be used for the assessment of conformity with spurious emissions limits

Frequency range (offset from channel centre)	Reference bandwidth
250 % of the CSP to 100 kHz	1 kHz
100 kHz to 500 kHz	10 kHz
> 500 kHz	The reference bandwidth shall be chosen according to the measurement frequency as follows: - 1 kHz between 9 kHz and 150 kHz - 10 kHz between 150 kHz and 30 MHz - 100 kHz between 30 MHz and 1 GHz - 1MHz above 1 GHz
NOTE: The limits above are consistent with CEPT/ERC/REC/74-01E [9] (cf. recommends 1, 4 and annex 2).	

5.1.6 Intermodulation attenuation

This requirement applies only to transmitters to be used in base stations. For the definition and the method of measurement, see clause 8.7.

Two classes of transmitter intermodulation attenuation are defined, the equipment shall fulfil one of the requirements:

- in general the intermodulation attenuation ratio shall be at least 40,0 dB for any intermodulation component;
- for base station equipment to be used in special service conditions (e.g. at sites where more than one transmitter will be in service) or when the regulatory authority makes it a condition of the licence, the intermodulation attenuation ratio shall be at least 70,0 dB for any intermodulation component. In the case where the performance is achieved by additional internal or external isolating devices (such as circulators) these are expected to be available at the time the measurements are made and shall be used for the measurements.

5.1.7 Transmitter attack time

For the definitions and the method of measurement, see clauses 8.8 and 8.10.1 and figures 13 and 14.

The transmitter attack time shall not exceed 25 ms ($t_{am} \leq t_{al}$).

5.1.8 Transmitter release time

For the definitions and the method of measurement, see clauses 8.9 and 8.10.1 and figure 15.

The transmitter release time shall not exceed 20 ms ($t_{rm} \leq t_{rl}$).

5.1.9 Transient behaviour of the transmitter

Transients may occur very often in some types of equipment (e.g. packet data systems) and are a potential source of interference for equipment operating both in adjacent channels and much further away in the spectrum.

The effects of transients can be very different from case to case because there are a number of possible mechanisms relating to such phenomena. For that reason, the method of measurement provided in the present document is expected to capture events that may have a high probability of happening, but some other unacceptable effects of transients may require specific methods to be detected and measured.

The method and limits provided in the present document are therefore the result of a compromise between an acceptable level of confidence and an acceptable complexity of the measurement.

For the definition and the method of measurement, see clause 8.10 and figures 13, 14 and 15.

5.1.9.1 Time domain analysis of power and frequency

When appropriate, the plots of carrier power (conducted) and carrier frequency as a function of time, covering in an appropriate way the transients, shall be included in test reports.

At any time when the carrier power is above $P_c - 30$ dB, the carrier frequency shall remain within half a channel separation (df_c) from the steady carrier frequency (F_c).

In case of equipment operating with channel separation of 12,5 kHz, the slopes of the plots "power as a function of time" corresponding to both attack and release times, shall be such that:

- $t_p \geq 0,10$ ms and $t_d \geq 0,10$ ms, for attack and release time;
- between the $P_c - 30$ dB point and the $P_c - 6$ dB point, both in the case of attack and release time, the sign of the slope shall not change.

In case of equipment operating with channel separation of 20 kHz or 25 kHz, the slopes of the plots "power as a function of time" corresponding to both attack and release times, shall be such that:

- $t_p \geq 0,05$ ms and $t_d \geq 0,05$ ms, for attack and release time;
- between the $P_c - 30$ dB point and the $P_c - 6$ dB point, both in the case of attack and release time, the sign of the slope shall not change.

5.1.9.2 Adjacent channel transient power

5.1.9.2.1 Equipment measured as constant envelope angle modulation equipment

The transient power, in the adjacent channels shall not exceed a value of:

- 60,0 dB below the carrier power (conducted) of the transmitter in decibels relative to the carrier power (dBc) without the need to be below $2 \mu\text{W}$ (-27,0 dBm), for channel separations of 20 kHz and 25 kHz;
- 50,0 dB below the carrier power (conducted) of the transmitter (in dBc) without the need to be below $2 \mu\text{W}$ (-27,0 dBm), for a channel separation of 12,5 kHz.

5.1.9.2.2 Equipment measured as non-constant envelope modulation equipment

Figure 1 shows the position of adjacent and alternate channels with respect to the wanted channel.

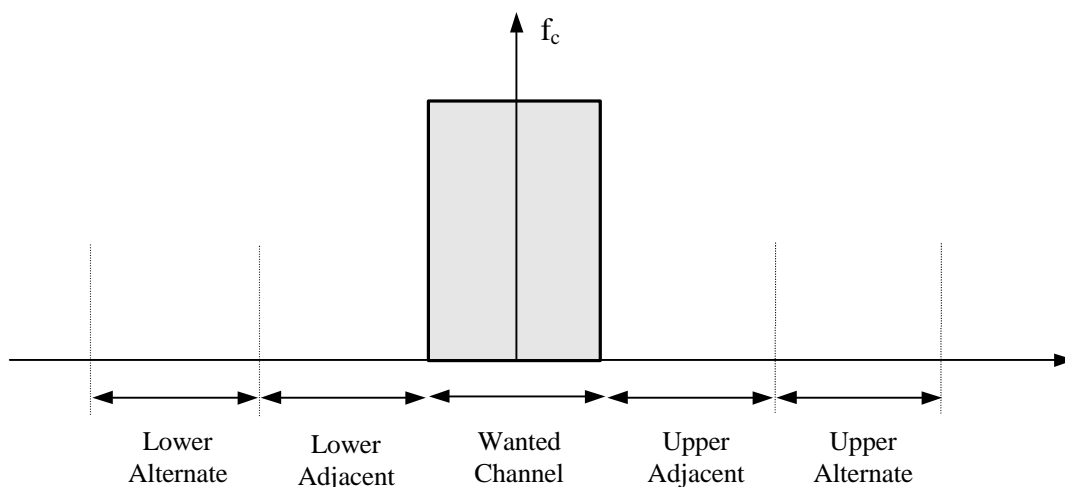

Figure 1: Adjacent and alternate channel definitions

The transient power, in the adjacent channels shall not exceed a value of:

- 60,0 dB below the carrier power (conducted) of the transmitter in decibels relative to the carrier power (dBc) without the need to be below 2 μ W (-27,0 dBm), for channel separations of 20 kHz and 25 kHz;
- 50,0 dB below the carrier power (conducted) of the transmitter (in dBc) without the need to be below 2 μ W (-27,0 dBm), for a channel separation of 12,5 kHz.

The transient power, in the alternate channels shall not exceed a value of:

- 65,0 dB below the carrier power (conducted) of the transmitter in decibels relative to the carrier power (dBc) without the need to be below 2 μ W (-27,0 dBm), for channel separations of 20 kHz and 25 kHz;
- 60,0 dB below the carrier power (conducted) of the transmitter (in dBc) without the need to be below 2 μ W (-27,0 dBm), for a channel separation of 12,5 kHz.

For measurements at 100 kHz and 1 MHz (from the wanted channel), the transient power shall not exceed a value:

- 65,0 dB below the carrier power (conducted) of the transmitter in decibels relative to the carrier power (dBc) without the need to be below 2 μ W (-27,0 dBm), for channel separations of 20 kHz and 25 kHz.
- 60,0 dB below the carrier power (conducted) of the transmitter (in dBc) without the need to be below 2 μ W (-27,0 dBm), for a channel separation of 12,5 kHz.

5.2 Receiver parameter limits

5.2.1 Maximum usable sensitivity (data or messages, conducted)

This measurement applies to all equipment covered by the present document.

For the definition and the method of measurement, see clause 9.1.

The maximum usable sensitivity shall not exceed an electromotive force (emf) of +3,0 dB μ V under normal test conditions, and an emf of +9,0 dB μ V under extreme test conditions.

5.2.2 Average usable sensitivity (data or messages, field strength)

This measurement applies only to equipment without a 50 Ω external antenna connector.

For the definition and the method of measurement see EN 300 390 [2], clause 9.1 (see also clause 9.2 of the present document).

For the categories of equipment and the average usable sensitivity limits, see EN 300 390 [2], clause 5.2.1.

5.2.3 Error behaviour at high input levels

For the definition and the method of measurement, see clause 9.4.

The bit error ratio (continuous bit streams) shall not exceed 10^{-4} .

The number of messages not correctly received (lost or corrupted) shall not exceed 1.

5.2.4 Co-channel rejection

For the definition and the method of measurement, see clause 9.5.

The value of the co-channel rejection ratio, expressed in dB, at the signal displacements given in the method of measurement, shall be:

- between -8,0 dB and 0 dB, for channel separations of 20 kHz and 25 kHz;
- between -12,0 dB and 0 dB, for channel separations of 12,5 kHz.

Any positive value is also acceptable.

5.2.5 Adjacent channel selectivity

For the definition and the method of measurement, see clause 9.6.

The adjacent channel selectivity for different channel separations shall not be less than the values given in table 4.

Table 4: Adjacent channel selectivity

	Channel separation	
	12,5 kHz	20/25 kHz
normal test conditions	60,0 dB	70,0 dB
extreme test conditions	50,0 dB	60,0 dB

5.2.6 Spurious response rejection

For the definition and the method of measurement, see clause 9.7.

At any frequency separated from the nominal frequency of the receiver by two channels or more, the spurious response rejection shall not be less than 70,0 dB.

5.2.7 Intermodulation response rejection

For the definition and the method of measurement, see clause 9.8.

The intermodulation response rejection ratio shall not be less than 70,0 dB for base station equipment and 65,0 dB for mobile and hand portable equipment.

5.2.8 Blocking or desensitization

For the definition and the method of measurement, see clause 9.9.

The blocking ratio for any frequency within the specified ranges shall not be less than 84,0 dB, except at frequencies on which spurious responses are found (clause 9.7).

5.2.9 Spurious radiations

For the definition and the method of measurement, see clause 9.10.

The power of any spurious radiation shall not exceed the values given in tables 5 and 6.

Table 5: Conducted components

Frequency range	Limit
9 kHz to 1 GHz	2,0 nW (-57 dBm)
above 1 GHz to 4 GHz, or above 1 GHz to 12,75 GHz (clause 9.10.2)	20,0 nW (-47 dBm)

Table 6: Radiated components

Frequency range	Limit
30 MHz to 1 GHz	2,0 nW (-57 dBm)
above 1 GHz to 4 GHz	20,0 nW (-47 dBm)

In the case of radiated measurements for hand portable stations the following conditions apply:

- for equipment having an external antenna socket, an artificial load shall be connected to the socket during the test;
- for equipment having no external antenna socket, the normal integral antenna shall be used.

5.3 Duplex operation - receiver limits

5.3.1 Receiver desensitization and maximum usable sensitivity (with simultaneous transmission and reception)

For the definition and the method of measurement, see clause 10.1.

The desensitization shall not exceed 3,0 dB and the limit of maximum usable sensitivity under normal test conditions shall be met (clause 5.2.1).

5.3.2 Receiver spurious response rejection (with simultaneous transmission and reception)

For the definition and the method of measurement, see clause 10.2.

At any frequency separated from the nominal frequency of the receiver by two channels or more, the spurious response rejection ratio shall be greater than 67,0 dB.

6 Test conditions, power sources and ambient temperatures

6.1 Normal and extreme test conditions

Measurements shall be made under normal test conditions, and also, where stated, under extreme test conditions.

The test conditions and procedures shall be as specified in clauses 6.2 to 6.5.

6.2 Test power source

During measurements, the power source of the equipment shall be replaced by a test power source, capable of producing normal and extreme test voltages as specified in clauses 6.3.2 and 6.4.2. The internal impedance of the test power source shall be low enough for its effect on the test results to be negligible. For the purpose of tests, the voltage of the power source shall be measured at the input terminals of the equipment.

If the equipment is provided with a permanently connected power cable, the test voltage shall be that measured at the point of connection of the power cable to the equipment.

For battery operated equipment the battery shall be removed and the test power source shall be applied as close to the battery terminals as practicable.

During tests the power source voltages shall be maintained within a tolerance ± 1 % relative to the voltage at the beginning of each test. The value of this tolerance is critical for power measurements. Using a smaller tolerance provides a better uncertainty value for these measurements.

6.3 Normal test conditions

6.3.1 Normal temperature and humidity

The normal temperature and humidity conditions for tests shall be any convenient combination of temperature and humidity within the following ranges:

- temperature: +15°C to +35°C;
- relative humidity: 20 % to 75 %.

When it is impracticable to carry out the tests under these conditions, a note to this effect, stating the ambient temperature and relative humidity during the tests, shall be added to test reports.

6.3.2 Normal test power source

6.3.2.1 Mains voltage

The normal test voltage for equipment to be connected to the mains shall be the nominal mains voltage. For the purpose of the present document, the nominal voltage shall be the declared voltage or any of the declared voltages for which the equipment was designed.

The frequency of the test power source corresponding to the ac mains shall be between 49 Hz and 51 Hz.

6.3.2.2 Regulated lead-acid battery power sources used on vehicles

When the radio equipment is intended for operation from the usual types of regulated lead-acid battery power source used on vehicles, the normal test voltage shall be 1,1 times the nominal voltage of the battery (for nominal voltages of 6 V and 12 V, these are 6,6 V and 13,2 V respectively).

6.3.2.3 Other power sources

For operation from other power sources or types of battery (primary or secondary), the normal test voltage shall be that declared by the equipment manufacturer.

6.4 Extreme test conditions

6.4.1 Extreme temperatures

For tests at extreme temperatures, measurements shall be made in accordance with the procedures specified in clause 6.5, at the upper and lower temperatures of the following range:

- -20°C to +55°C.

For the purpose of the note to table 1, clause 5.1.1, an additional reduced extreme temperature range of 0°C to +30°C shall be used when appropriate.

Test reports shall state the temperature range used.

6.4.2 Extreme test source voltages

6.4.2.1 Mains voltage

The extreme test voltage for equipment to be connected to an ac mains source shall be the nominal mains voltage ± 10 %.

6.4.2.2 Regulated lead-acid battery power sources on vehicles

When the radio equipment is intended for operation from the usual type of regulated lead-acid battery power sources used on vehicles, the extreme test voltages shall be 1,3 and 0,9 times the nominal voltage of the battery (for a nominal voltage of 6 V, these are 7,8 V and 5,4 V respectively and for a nominal voltage of 12 V, these are 15,6 V and 10,8 V respectively).

6.4.2.3 Power sources using other types of batteries

The lower extreme test voltage for equipment with power sources using batteries shall be as follows:

- for the Leclanché or the lithium type of battery:
 - 0,85 times the nominal voltage of the battery;
- for the mercury type or nickel-cadmium type of battery:
 - 0,9 times the nominal voltage of the battery.

No upper extreme test voltages apply.

In the case where no upper extreme test voltage above the nominal voltage is applicable, the corresponding four extreme test conditions are:

- V_{\min} / T_{\min} , V_{\min} / T_{\max} ;
- $(V_{\max} = \text{nominal}) / T_{\min}$, $(V_{\max} = \text{nominal}) / T_{\max}$.

6.4.2.4 Other power sources

For equipment using other power sources, or capable of being operated from a variety of power sources, the extreme test voltages shall be, as appropriate, either those selected by the manufacturer or those agreed between the equipment manufacturer and the testing laboratory. They shall be recorded in test reports.

6.5 Procedure for tests at extreme temperatures

Before measurements are made the equipment shall have reached thermal balance in the test chamber. The equipment shall be switched off during the temperature stabilizing period.

In the case of equipment containing temperature stabilization circuits designed to operate continuously, the temperature stabilization circuits may be switched on for 15 minutes after thermal balance has been obtained, and the equipment shall then meet the specified requirements. For such equipment the manufacturer shall provide for the power source circuit feeding the crystal oven, to be independent of the power source for the rest of the equipment.

If the thermal balance is not checked by measurements, a temperature stabilizing period of at least one hour, or a longer period of time as may be decided by the testing laboratory, shall be allowed. The sequence of measurements shall be chosen, and the humidity content in the test chamber shall be controlled so that excessive condensation does not occur.

6.5.1 Procedure for equipment designed for continuous operation

If the manufacturer states that the equipment is designed for continuous operation, the test procedure shall be as follows.

Before tests at the upper extreme temperature the equipment shall be placed in the test chamber and left until thermal balance is attained. The equipment shall then be switched on in the transmit condition for a period of half an hour after which the equipment shall meet the specified requirements.

Before tests at the lower extreme temperature the equipment shall be left in the test chamber until thermal balance is attained, then switched to the standby or receive condition for a period of one minute after which the equipment shall meet the specified requirements.

6.5.2 Procedure for equipment designed for intermittent operation

If the manufacturer states that the equipment is designed for intermittent operation, the test procedure shall be as follows.

Before tests at the upper extreme temperature the equipment shall be placed in the test chamber and left until thermal balance is attained. The equipment shall then be switched on for one minute in the transmit condition, followed by four minutes in the receive condition, after which the equipment shall meet the specified requirements.

Before tests at the lower extreme temperature the equipment shall be left in the test chamber until thermal balance is attained, then switched to the standby or receive condition for one minute after which the equipment shall meet the specified requirements.

7 General conditions

7.1 Arrangements for test signals applied to the receiver input

Sources of test signals for application to the receiver input shall be connected in such a way that the source impedance presented to the receiver input is 50 Ω (non-reactive, clause 7.6).

This requirement shall be met irrespective of whether one or more signals using a combining network are applied to the receiver simultaneously.

The levels of the test signals at the receiver input terminals (RF socket) shall be expressed in terms of emf.

The effects of any intermodulation products and noise produced in the test signal sources shall be negligible.

7.2 Receiver mute or squelch facility

If the receiver is equipped with a mute or squelch circuit, this shall be made inoperative for the duration of the measurements.

7.3 Normal test signals (wanted and unwanted signals)

7.3.1 Equipment measured as constant envelope angle modulation equipment

When the equipment is designed to transmit continuous bit streams (e.g. data, facsimile, image transmission, digital speech) the normal test signal shall be as follows:

- signal D-M0, consisting of an infinite series of 0 bits;
- signal D-M1, consisting of an infinite series of 1 bits;
- signal D-M2, consisting of a pseudo-random bit sequence of at least 511 bits according to ITU-T Recommendation O.153 [6];
- signal D-M2', this is the same type as D-M2, but the pseudo-random bit sequence is independent of D-M2 (perhaps identical with D-M2 but started at another point of time);
- signal A-M3, consisting of an RF signal, modulated by an audio frequency signal of 400 Hz with a deviation of 12 % of the channel separation. This signal is used as an unwanted signal.

Applying an infinite series of 0 bits or 1 bits does not normally produce the typical bandwidth. Signal D-M2 is designed to produce a good approximation of the typical bandwidth.

Information concerning technical characteristics of modulation, coding and format is given in annex E.

If the transmission of a continuous bit stream is not possible, the normal test signal shall be trains of correctly coded bits or messages. This signal shall be, as appropriate, either selected by the manufacturer or agreed between the manufacturer and the testing laboratory, and shall produce the greatest radio frequency occupied bandwidth. Details of this test signal shall be included in test reports.

In this case, the encoder, which is associated with the transmitter, shall be capable of supplying the normal test signal. The resulting modulation is called the normal test modulation. If possible this should be continuous modulation for the duration of the measurements.

For measurements using the up-down method (see note) it shall be possible to trigger single test signals "D-M3" either manually or by an automatic testing system.

The test signal D-M4 consists of correctly coded signals, messages transmitted sequentially, one by one, without gaps between them. This transmission is necessary for measurements such as adjacent channel power (clauses 5.1.4 and 8.5) and spurious emissions (clauses 5.1.5 and 8.6).

The signal A-M3 is used as an unwanted signal for measurements such as co-channel rejection (clauses 5.2.4 and 9.5) and adjacent channel selectivity (clauses 5.2.5 and 9.6).

Details of D-M3 and D-M4 shall be recorded in test reports.

NOTE 1: A method of measurement implementing the "up-down method" can be found in clause 9.1.3 (method of measurement of the maximum usable sensitivity using messages).

NOTE 2: Transmitters may have limitations concerning their maximum continuous transmit time and/or their transmission duty cycle. It is intended that such limitations be respected during testing.

7.3.2 Equipment measured as non constant envelope modulation equipment

When the equipment is designed to transmit continuous bit streams (e.g. data, facsimile, image transmission, digital speech) the normal test signal shall be as follows:

- signal D-M5, consisting of a pseudo-random bit sequence of at least 511 bits according to ITU-T Recommendation O.153 [6];
- signal D-M5', this is the same type as D-M5, but the pseudo-random bit sequence is independent of D-M5 (perhaps identical with D-M5 but started at another point of time);
- signal C1 shall be any signal that provides a constant envelope of output power at the output of the transmitter. This may be a CW tone or a modulated signal with constant envelope (e.g. GMSK). The envelope shall be flat to ± 1 dB.

If the transmission of a continuous bit stream is not possible, the normal test signal D-M7 shall be trains of correctly coded bits or messages. This signal shall be, as appropriate, either selected by the manufacturer or agreed between the manufacturer and the testing laboratory, and shall produce the greatest radio frequency occupied bandwidth. Details of this test signal shall be included in test reports.

In this case, the encoder, which is associated with the transmitter, shall be capable of supplying the normal test signal. The resulting modulation is called the normal test modulation. If possible this should be continuous modulation for the duration of the measurements.

The test signal D-M7 consists of correctly coded signals, messages transmitted sequentially, one by one, without gaps between them. This transmission is necessary for measurements such as adjacent channel power (clauses 5.1.4 and 8.5) and spurious emissions (clauses 5.1.5 and 8.6).

For the purpose of testing the carrier power in clauses 5.1.2 and 5.1.3, test signals D-M5 and D-M7 should produce the largest value of output power (PEP) possible with digital modulation. If this is not the case then a test signal that does produce the largest possible value of output power (PEP) with digital modulation should be used in the testing in clauses 5.1.2 and 5.1.3.

The PEP is the average power supplied to the artificial antenna by a transmitter during one RF cycle at the highest crest of the modulation envelope. For practical purposes the methods of measurements in clauses 8.2.2.2 and 8.3.2.2 should be used.

Details of D-M5 and D-M7 shall be recorded in test reports.

7.4 Encoder for receiver measurements

Whenever needed and in order to facilitate measurements on the receiver, an encoder for the data system is expected to accompany the equipment to be measured, together with details of the normal modulation process. The encoder is used to modulate a signal generator for use as a test signal source.

In the case of equipment unable to operate with continuous bit streams, the encoder shall be capable of operation in a repetitive mode, with intervals between each message that are not less than the reset time of the receiver.

Complete details of all codes and code format(s) used shall be made available for the measurements.

7.5 Transceiver data interface

Equipment that does not integrate the keyboard and display used for normal operation shall provide a V.24/V.28 interface (preferably) or other suitable interfaces.

In the case where the equipment uses a proprietary interface, appropriate means and documentation allowing for the equipment to be tested are expected to be provided in View of the measurements.

Variation in the level of the input signals, within the specified limits for that interface, shall have no measurable influence on the characteristics of the signals on the radio path.

7.6 Impedance

In the present document the term "50 Ω " is used for a 50 Ω non-reactive impedance.

7.7 Artificial antenna

Tests shall be carried out using an artificial antenna which shall be a substantially non-reactive non-radiating load of 50 Ω connected to the antenna connector.

NOTE: Some of the methods of measurement described in the present document for the transmitters, allow for two or more different test set ups in order to perform that measurement, all supposed to provide equivalent results. The corresponding figures illustrate therefore one particular test set up, and are given as examples. In many of those figures, power attenuators (providing a substantially non-reactive non-radiating load of 50 Ω to the antenna connector) have been shown (and not "artificial antennas" as defined here above).

7.8 Tests of equipment with a duplex filter

If the equipment is provided with a built-in duplex filter or with a separate associated filter, the requirements of the present document shall be met when the measurements are carried out using the antenna connector of the filter.

7.9 Facilities for access

7.9.1 Analogue access

In order to simplify the measurements in clauses 9.2 and 9.7, temporary access to a point where the amplitude of the analogue output of the RF part can be measured should be provided, e.g. Intermediate Frequency (IF) output or the demodulated subcarrier point may be provided for the equipment to be tested. This access can be used to determine or verify the frequency where a spurious response is expected.

7.9.2 Test points for bit stream measurements

It is recognized that it is not always possible to measure the air interface bit stream. The manufacturer shall define the test points at which the equipment shall be tested in order to make the measurements on bit streams according to clauses 8, 9 and 10.

Figure 2 is presented as an example for clarification only.

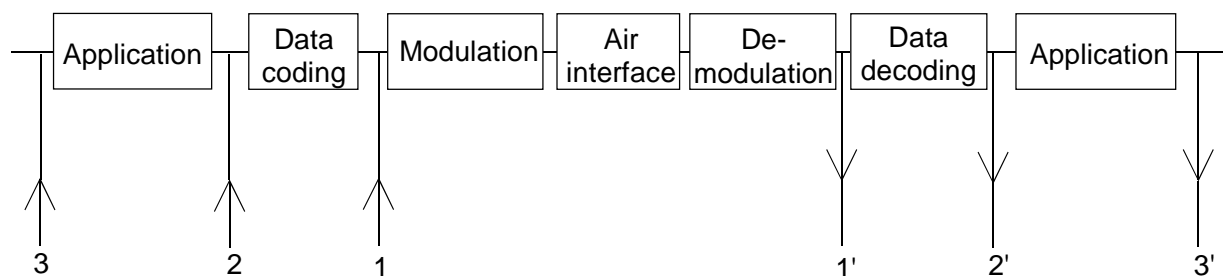

Figure 2: Test points for bit stream measurements

It should be noted that the closer the test access point is located to the air interface (figure 2), the fewer the number of Variants that may have to be measured because the measurement is less application dependent.

The tests shall be performed by use of corresponding test points (1,1' or 2,2' or 3,3').

The test points used shall be recorded in test reports.

7.9.3 Coupling arrangements

If the equipment does not have an external antenna connector, arrangements shall be made by the manufacturer to couple the unit to be tested to the test equipment by a method which does not affect the radiated field (e.g. acoustic, ultra sonic or optic) and according to clauses 7.9.3.1 and 7.9.3.2.

These arrangements are required for testing integral antenna equipment in accordance with EN 300 390 [2].

7.9.3.1 Arrangements for measurements with continuous bit streams

For the measurements of the receiver on a test site, arrangements to couple the unit to be tested to the bit error ratio measuring device shall be available (clause 7.9.2).

Furthermore, the manufacturer may also provide another facility to give access to the analogue information (clause 7.9.1).

7.9.3.2 Arrangements for measurements with messages

For the measurement of the receiver on a test site, arrangements to couple the unit to be tested to the error observation device (or to an operator) shall be available.

Furthermore, the manufacturer shall also provide another facility to give access to the analogue information (clause 7.9.1).

7.10 Test site and general arrangements for measurements involving the use of radiated fields

For guidance see annex A: descriptions of the radiated measurement arrangements are included in this annex.

7.11 Modes of operation of the transmitter

For the purpose of the measurements according to the present document, there should preferably be a facility to operate the transmitter unmodulated.

The method of obtaining an unmodulated carrier or special types of modulation patterns may also, as appropriate, either be selected by the manufacturer or be agreed between the manufacturer and the test laboratory. It shall be described in test reports.

It may involve suitable temporary internal modifications of the equipment under test. For instance in the case of direct Frequency Shift Keying (FSK), a means to continuously transmit a sequence D-M0 containing only "zeros" and a sequence D-M1 containing only "ones" is desirable.

8 Methods of measurement for transmitter parameters

When performing transmitter tests on equipment designed for intermittent operation, the specified maximum transmit time shall not be exceeded.

8.1 Frequency error

This measurement is made if the equipment is capable of producing an unmodulated carrier or a modulated carrier, provided that the presence of modulation allows sufficiently accurate measurement of the carrier frequency. Otherwise the adjacent channel power shall also be measured under extreme test conditions and the limits given in clause 5.1.4 shall be met.

8.1.1 Definition

The frequency error of the transmitter is the difference between the measured carrier frequency in the absence of modulation (or with modulation, provided that the presence of modulation allows sufficiently accurate measurement of the carrier frequency,) and the nominal frequency of the transmitter.

8.1.2 Method of measurement

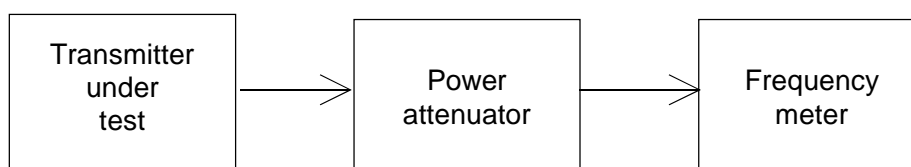

Figure 3: Measurement arrangement

The equipment shall be connected to the artificial antenna (clause 7.7).

The carrier frequency shall be measured in the absence of modulation. The measurement shall be made under normal test conditions (clause 6.3) and extreme test conditions (clauses 6.4.1 and 6.4.2 applied simultaneously).

The limit(s) corresponding to this parameter can be found in clause 5.1.1.

8.2 Carrier power (conducted)

It is assumed that the appropriate Administration will state the maximum transmitter output power/effective radiated power (as a condition for issuing licences).

If the equipment is designed to operate with different carrier powers, the rated power for each level, or range of levels, shall be declared by the manufacturer. The power adjustment control shall not be accessible to the user.

The requirements of the present document shall be met for all power levels at which the transmitter is intended to operate. For practical reasons, measurements shall be performed only at the lowest and highest power level at which the transmitter is intended to operate.

8.2.1 Definitions

8.2.1.1 Equipment measured as constant envelope angle modulation equipment

The transmitter carrier power (conducted) is the mean power delivered to the artificial antenna during a radio frequency cycle.

The rated output power is the carrier power (conducted) of the equipment declared by the manufacturer.

8.2.1.2 Equipment measured as non-constant envelope modulation equipment

The transmitter carrier power (conducted) is the mean power delivered to the artificial antenna during a radio frequency cycle at the highest crest of the modulation envelope (PEP: Peak Envelope Power).

The rated output power is the carrier power (conducted) of the equipment declared by the manufacturer.

8.2.2 Method of measurement

8.2.2.1 Equipment measured as constant envelope angle modulation equipment

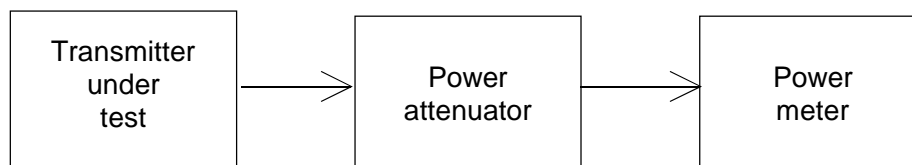

Figure 4: Measurement arrangement

The measurement shall be performed preferably in the absence of modulation.

When it is not possible to measure it in the absence of modulation, this fact shall be stated in test reports (clause 7.11).

The transmitter shall be connected to an artificial antenna (clause 7.7), and the power delivered to this artificial antenna shall be measured.

The measurement shall be made under normal test conditions (clause 6.3) and extreme test conditions (clauses 6.4.1 and 6.4.2 applied simultaneously).

The limit(s) corresponding to this parameter can be found in clause 5.1.2.

8.2.2.2 Equipment measured as non-constant envelope modulation equipment

The measurement shall be performed with test signals D-M5 or D-M7 as appropriate.

The transmitter shall be connected to an artificial antenna (clause 7.7), and the power delivered to this artificial antenna shall be measured. The measuring instrument shall have a measurement bandwidth not less than sixteen times the channel bandwidth.

The measurement shall be made under normal test conditions (clause 6.3) and extreme test conditions (clauses 6.4.1 and 6.4.2 applied simultaneously).

The limit(s) corresponding to this parameter can be found in clause 5.1.2.

8.3 Effective radiated power (field strength)

This measurement applies only to equipment without an external antenna connector.

If the equipment is designed to operate with different carrier powers, the rated power for each level, or range of levels, shall be declared by the manufacturer. The power adjustment control shall not be accessible to the user.

The requirements of the present document shall be met for all power levels at which the transmitter is intended to operate. For practical reasons measurements shall be performed only at the lowest and highest power level at which the transmitter is intended to operate.

8.3.1 Definition

8.3.1.1 Equipment measured as constant envelope angle modulation equipment

The effective radiated power is the power radiated in the direction of the maximum field strength under specified conditions of measurements.

The rated effective radiated power is the effective radiated power of the equipment as declared by the manufacturer.

8.3.1.2 Equipment measured as non-constant envelope modulation equipment

The effective radiated power of the transmitter is the value of the output PEP for any condition of modulation radiated in the direction of the maximum field strength.

The rated effective radiated power is the effective radiated power of the equipment as declared by the manufacturer.

8.3.2 Methods of measurement

Test site

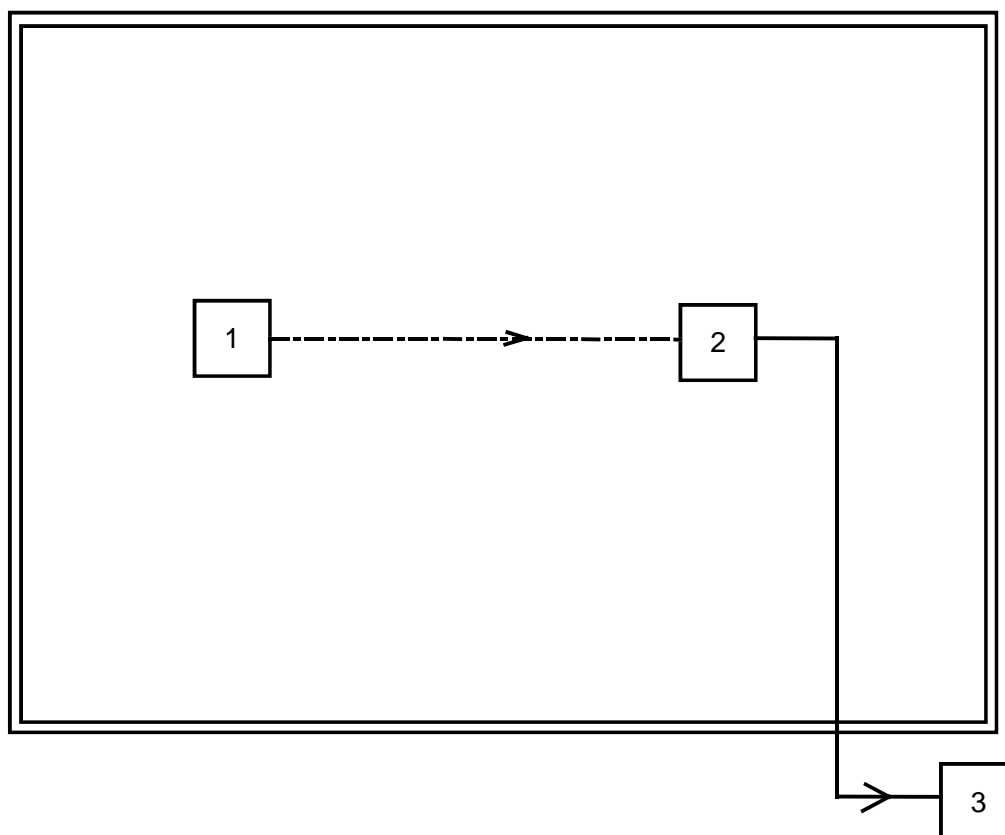

- 1) Transmitter under test
- 2) Test antenna
- 3) Spectrum analyser or selective Voltmeter (test receiver)

Figure 5: Measurement arrangement

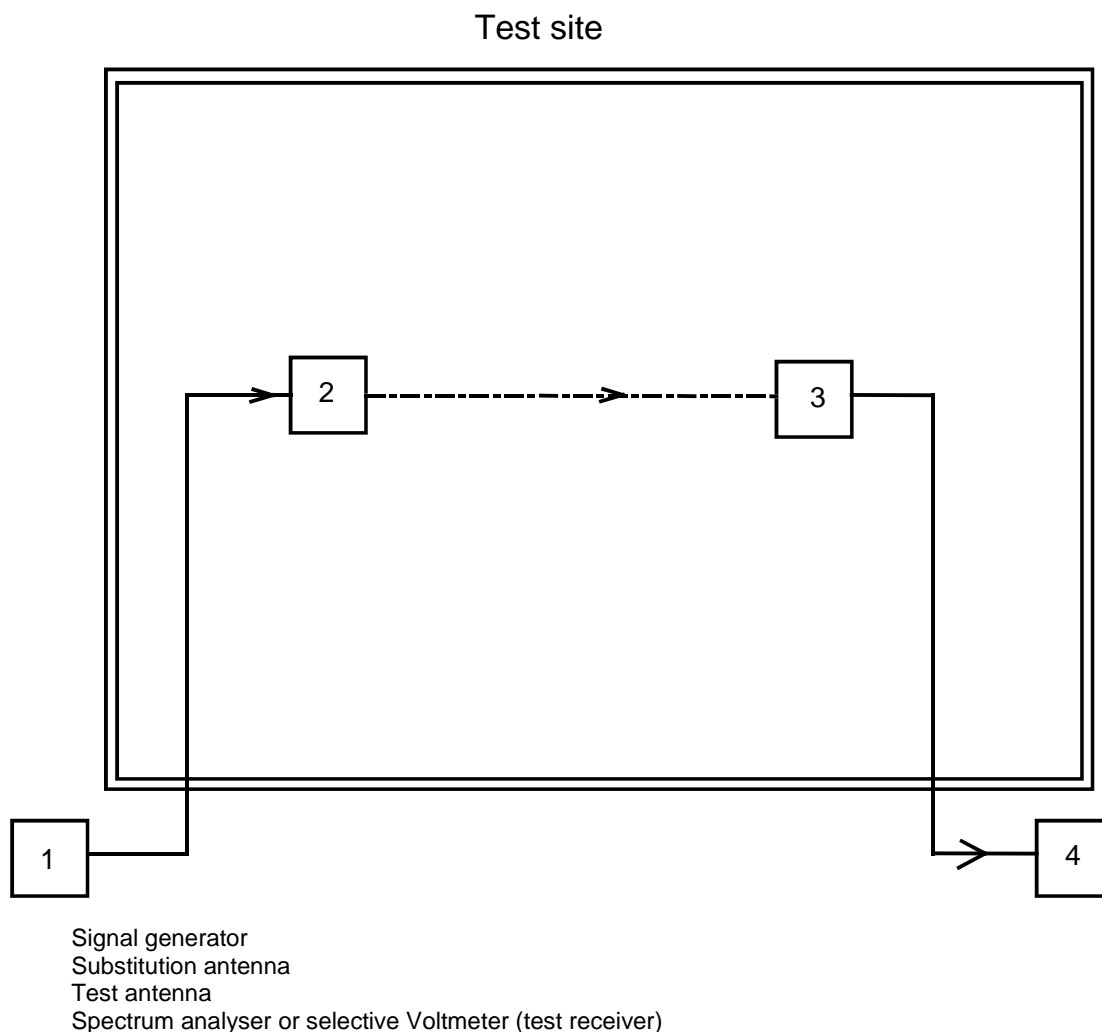

Figure 6: Measurement arrangement

8.3.2.1 Equipment measured as constant envelope angle modulation equipment

The measurement shall be performed preferably in the absence of modulation.

When it is not possible to measure it in the absence of modulation this fact shall be stated in test reports (clause 7.11).

The measurement procedure shall be as follows:

- a) a test site, selected from annex A, which fulfils the requirements of the specified frequency range of this measurement shall be used. The test antenna shall be orientated initially for vertical polarization unless otherwise stated;

The transmitter under test shall be placed at the specified height on a non-conducting support in the position closest to normal use as declared by the manufacturer. This position shall be recorded in test reports.

- b) the spectrum analyser or selective Voltmeter shall be tuned to the transmitter carrier frequency. The test antenna shall be raised or lowered through the specified height range until the maximum signal level is detected on the spectrum analyser or selective Voltmeter;

The test antenna need not be raised or lowered if the measurement is carried out on a test site according to clause A.3 (i.e. an anechoic chamber).

- c) the transmitter shall be rotated through 360° about a vertical axis until a higher maximum signal is received;

- d) the test antenna shall be raised or lowered again through the specified height range until a maximum is obtained. This level shall be recorded. (This maximum may be a lower value than the value obtainable at heights outside the specified limits);

The test antenna need not be raised or lowered if the measurement is carried out on a test site according to clause A.3 (i.e. an anechoic chamber).

- e) using the measurement arrangement of figure 6, the substitution antenna (clauses A.1.3 to A.1.5) shall replace the transmitter antenna in the same position and in vertical polarization. The frequency of the signal generator shall be adjusted to the transmitter carrier frequency. The test antenna shall be raised or lowered as necessary to ensure that the maximum signal is still received;

The test antenna need not be raised or lowered if the measurement is carried out on a test site according to clause A.3 (i.e. an anechoic chamber).

The input signal to the substitution antenna shall be adjusted in level until an equal or a known related level to that detected from the transmitter is obtained in the test receiver. The maximum carrier radiated power is equal to the power supplied by the signal generator, increased by the known relationship if necessary and after corrections due to the gain of the substitution antenna and the cable loss between the signal generator and the substitution antenna.

- f) steps b) to e) above shall be repeated with the test antenna and the substitution antenna orientated in horizontal polarization.

The measure of the effective radiated power is the larger of the two power levels recorded at the input to the substitution antenna, corrected for the gain of the antenna if necessary.

The limit(s) corresponding to this parameter can be found in clause 5.1.3.

8.3.2.2 Equipment measured as non-constant envelope modulation equipment

Evaluation of CW-to-PEP correction factor for signal C1:

The transmitter permanent internal or a temporary internal 50 Ω RF connector shall be connected to a 50 Ω power attenuator. The transmitter shall be switched on with test signal C1 (see clause 7.3.2) applied and the PEP delivered shall be measured. The measuring instrument shall have a measurement bandwidth not less than sixteen times the CBW. The mean power delivered shall also be measured. The difference between the PEP and the mean power shall be less than 1 dB.

Modulation test signal D-M5 or D-M7 as appropriate, (see clause 7.3.2) shall then be applied at the transmitter. The PEP delivered to its artificial antenna shall be measured.

The difference (in dB) between the PEP measured for D-M5 or D-M7 modulation and the mean power measured for C1 modulation shall be recorded. This value is the CW-to-PEP correction factor for signal C1.

The measurement procedure shall be as follows:

- a) a test site, selected from annex A, which fulfils the requirements of the specified frequency range of this measurement shall be used. The test antenna shall be orientated initially for Vertical polarization unless otherwise stated;

The transmitter under test shall be placed at the specified height on a non-conducting support in the position closest to normal use as declared by the manufacturer. This position shall be recorded in test reports.

- b) the transmitter shall be switched on with test signal C1 (see clause 7.3.2) applied and the spectrum analyser or selective Voltmeter shall be tuned to the transmitter carrier frequency. The test antenna shall be raised or lowered through the specified height range until the maximum signal level is detected on the spectrum analyser or selective Voltmeter;

The test antenna need not be raised or lowered if the measurement is carried out on a test site according to clause A.3 (i.e. an anechoic chamber).

- c) the transmitter shall be rotated through 360° about a Vertical axis until a higher maximum signal is received;

- d) the test antenna shall be raised or lowered again through the specified height range until a maximum is obtained. This level shall be recorded. (This maximum may be a lower value than the value obtainable at heights outside the specified limits);

The test antenna need not be raised or lowered if the measurement is carried out on a test site according to clause A.3 (i.e. an anechoic chamber).

- e) using the measurement arrangement of figure 6, the substitution antenna (clauses A.1.3 to A.1.5) shall replace the transmitter antenna in the same position and in Vertical polarization. The frequency of the signal generator shall be adjusted to the transmitter carrier frequency. The test antenna shall be raised or lowered as necessary to ensure that the maximum signal is still received;

The test antenna need not be raised or lowered if the measurement is carried out on a test site according to clause A.3 (i.e. an anechoic chamber).

The input signal to the substitution antenna shall be adjusted in level until an equal or a known related level to that detected from the transmitter is obtained in the test receiver. The maximum carrier radiated power is equal to the power supplied by the signal generator, corrected by the CW-to-PEP correction factor for signal C1, increased by the known relationship if necessary and after corrections due to the gain of the substitution antenna and the cable loss between the signal generator and the substitution antenna.

- f) steps b) to e) above shall be repeated with the test antenna and the substitution antenna orientated in horizontal polarization.

The measure of the effective radiated power is the larger of the two power levels recorded at the input to the substitution antenna, corrected for the gain of the antenna if necessary.

The limit(s) corresponding to this parameter can be found in clause 5.1.3.

8.4 Maximum permissible frequency deviation

This measurement is only performed with equipment using subcarrier FSK-modulation.

It is more particularly suitable for use in the case of field measurements. No limits are given for this parameter.

8.4.1 Definition

The maximum permissible frequency deviation is the maximum value of the frequency deviation, measured according to the present document.

8.4.2 Method of measurement

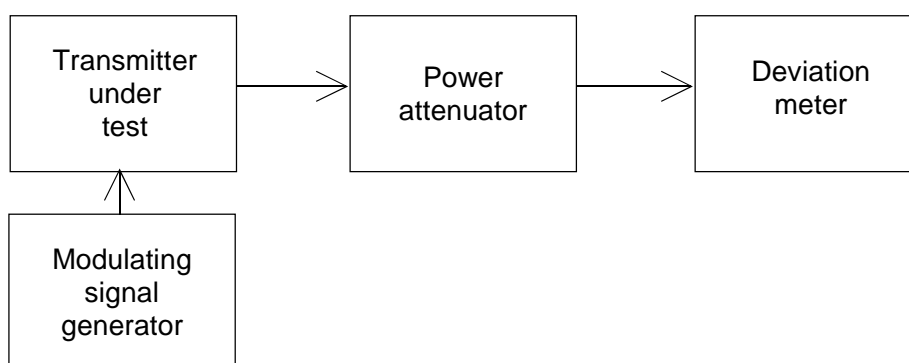

Figure 7: Measurement arrangement

The frequency deviation shall be measured at the output of the transmitter connected to an artificial antenna (clause 7.7), by means of a deviation meter capable of measuring the maximum deviation, including that due to any harmonics and intermodulation products which may be generated in the transmitter.

Two types of measurement shall be carried out:

- one with the test signal D-M0, producing a frequency deviation of F_0 ;
- the other with the test signal D-M1, producing a frequency deviation of F_1 .

8.5 Adjacent channel power

8.5.1 Definition

The adjacent channel power is that part of the total power output of a transmitter under defined conditions of modulation, which falls within a specified pass-band centred on the nominal frequency of either of the adjacent channels. This power is the sum of the mean power produced by the modulation, hum and noise of the transmitter.

8.5.2 Method of measurement

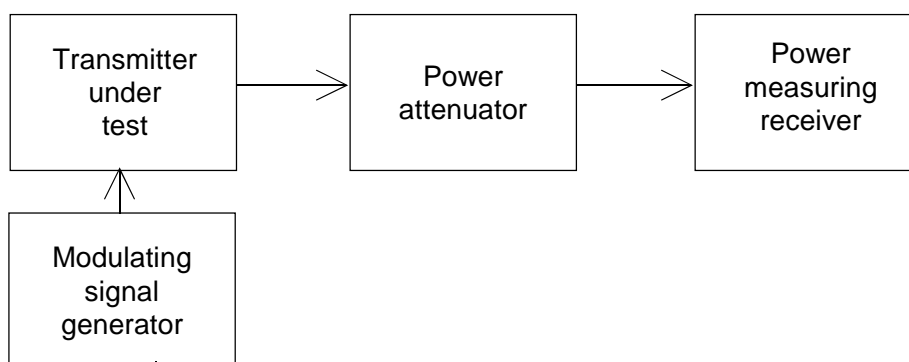

Figure 8: Measurement arrangement

The adjacent channel power may be measured, as follows, with a power measuring receiver which conforms to annex B (referred to in this clause as the "receiver"):

- a) the transmitter shall be operated at the carrier power determined in clause 8.2 under normal test conditions (clause 6.3). The output of the transmitter shall be linked to the input of the "receiver" by a connecting device such that the impedance presented to the transmitter is 50Ω and the level at the "receiver input" is appropriate;
- b) with the transmitter unmodulated, the tuning of the "receiver" shall be adjusted so that a maximum response is obtained. This is the 0 dB response point. The "receiver" attenuator setting and the reading of the meter shall be recorded. If an unmodulated carrier cannot be obtained, then the measurement shall be made with the transmitter modulated with the normal test signal D-M2, D-M4, D-M5 or D-M7 as appropriate, according to clause 7.3, in which case this fact shall be recorded in test reports;
- c) the frequency of the "receiver" shall be adjusted above the carrier so that the "receiver" -6 dB response nearest to the transmitter carrier frequency is located at a displacement from the nominal carrier frequency as given in table 7;

Table 7: Frequency displacement

Channel separation (kHz)	Specified necessary bandwidth (kHz)	Displacement from the -6 dB point (kHz)
12,5	8,5	8,25
20	14	13
25	16	17

- d) the transmitter shall be modulated by a normal test signal D-M2, D-M4, D-M5 or D-M7 as appropriate, according to clause 7.3;

- e) the "receiver" Variable attenuator shall be adjusted to obtain the same meter reading as in step b), or a known relation to it;
- f) the ratio of the adjacent channel power to the carrier power is the difference between the attenuator settings in steps b) and e), corrected for any differences in the reading of the meter;

For each adjacent channel, the adjacent channel power shall be recorded.

- g) the measurement shall be repeated with the frequency of the "receiver" adjusted below the carrier so that the "receiver" -6 dB response nearest to the transmitter carrier frequency is located at a displacement from the nominal carrier frequency as given in table 7;
- h) the adjacent channel power of the equipment under test shall be expressed as the higher of the two values recorded in step f) for the upper and lower channels nearest to the channel considered;
- i) when it is not possible to perform the measurement of frequency error in the absence of modulation (clause 8.1), this measurement shall be repeated under extreme test conditions (clauses 6.4.1 and 6.4.2 applied simultaneously).

The limit(s) corresponding to this parameter can be found in clause 5.1.4.

8.6 Spurious emissions

8.6.1 Definition

Spurious emissions are emissions at frequencies other than those of the carrier and sidebands associated with normal modulation.

The level of spurious emissions shall be measured by:

either:

- a) their power level in a specified load (conducted spurious emission); and
- b) their effective radiated power when radiated by the cabinet and structure of the equipment (cabinet radiation);
or
- c) their effective radiated power when radiated by the cabinet and by the integral antenna, in the case of hand portable equipment fitted with such an antenna and no external RF connector.

8.6.2 Method of measuring the power level

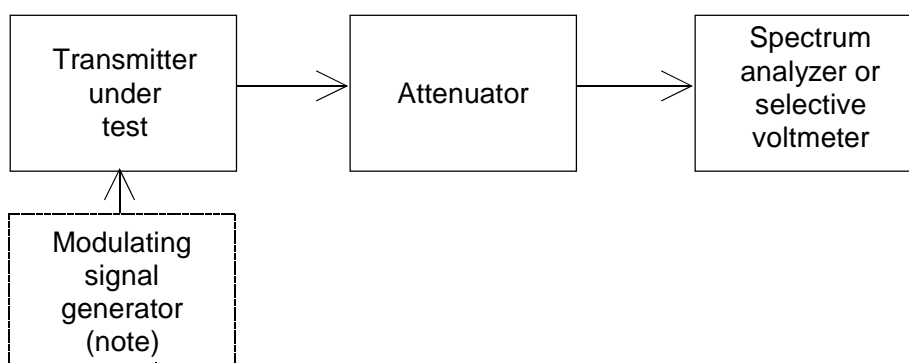

NOTE: Used only if it is not possible to perform the measurement with the transmitter unmodulated.

Figure 9: Measurement arrangement

This method applies only to equipment having an external connector.

Spurious emissions shall be measured as the power level of any discrete signal (excluding the wanted signal) delivered into a 50 Ω load. This may be done by connecting the transmitter output through an attenuator to a spectrum analyser

(see clause B.2) or selective Voltmeter, or by monitoring the relative levels of the spurious signals delivered to an artificial antenna (see clause 7.7).

If possible, the measurement shall be made with the transmitter unmodulated. If this is not possible, the transmitter shall be modulated by the normal test signal D-M2, D-M4, D-M5 or D-M7 as appropriate (see clause 7.3). If possible the modulation should be continuous for the duration of the measurement.

The measurements shall be made, for equipment operating on frequencies not exceeding 470 MHz, in the frequency range 9 kHz to 4 GHz, and for equipment operating on frequencies above 470 MHz, additionally in the frequency range 4 GHz to 12,75 GHz, except for the channel on which the transmitter is intended to operate, and its adjacent channels.

The measurement shall be repeated with the transmitter in the "stand-by" position.

8.6.2.1 Equipment measured as constant envelope angle modulation equipment

The resolution bandwidth of the measuring instrument shall be the smallest bandwidth available which is greater than the spectral width of the spurious component being measured. This shall be considered to be achieved when the next highest bandwidth causes less than 1 dB increase in amplitude.

The conditions used in the relevant measurements shall be recorded in test reports.

The limit(s) corresponding to this parameter can be found in clause 5.1.5.

8.6.2.2 Equipment measured as non-constant envelope modulation equipment

As a general rule, the resolution bandwidth of the measuring receiver should be equal to the reference bandwidth as given in clause 5.1.5 (table 3 b)).

"To improve measurement accuracy, sensitivity and efficiency, the resolution bandwidth can be different from the reference bandwidth. When the resolution bandwidth is smaller than the reference bandwidth, the result should be integrated over the reference bandwidth. When the resolution bandwidth is greater than the reference bandwidth, the result for broadband spurious emissions should be normalized to the bandwidth ratio. For discrete spur, normalization is not applicable, while integration over the reference bandwidth is still applicable" (extract from CEPT/ERC/REC 74.01 E [9], recommend 4, page 5).

The conditions used in the relevant measurements shall be reported in the test report.

The limit(s) corresponding to this parameter can be found in clause 5.1.5.

8.6.3 Method of measuring the effective radiated power

Test site

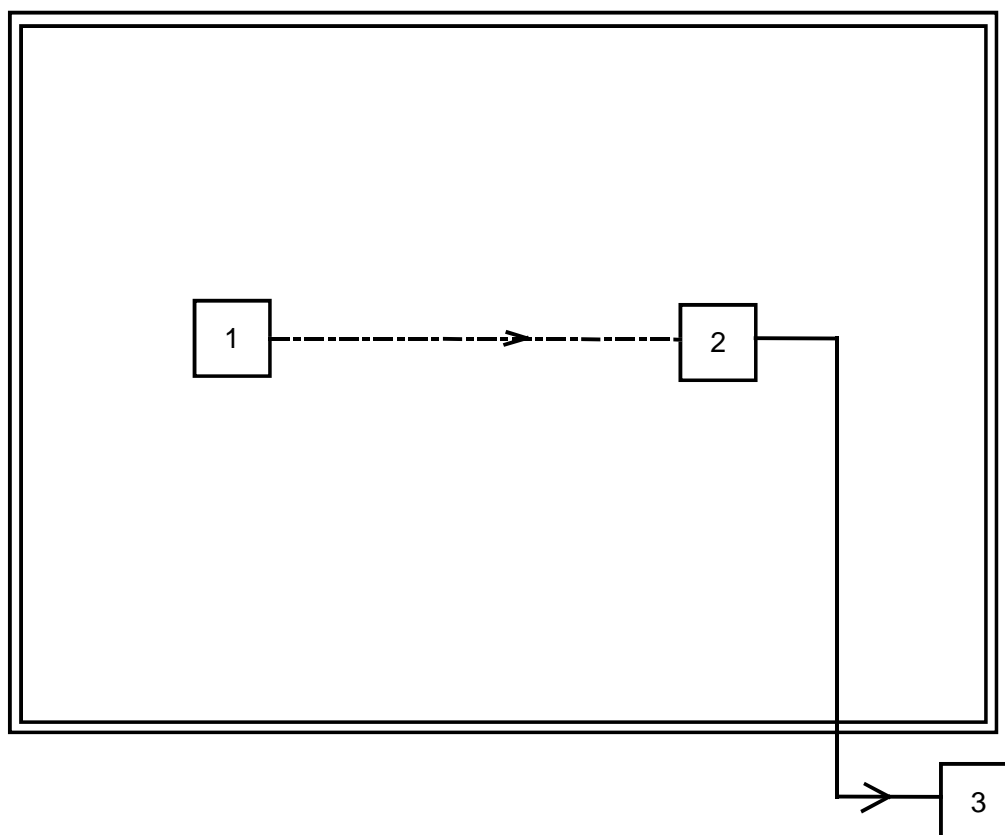

- 1) Transmitter under test
- 2) Test antenna
- 3) Spectrum analyser or selective Voltmeter (test receiver)

Figure 10: Measurement arrangement

8.6.3.1 Equipment measured as constant envelope angle modulation equipment

The measurement procedure shall be as follows:

- a) on a test site, fulfilling the requirements of annex A, the sample shall be placed at the specified height on the support;

The transmitter shall be operated at the carrier power as specified under clause 8.2, delivered to:

- an artificial antenna (clause 7.7) for equipment having an external antenna connector (clause 8.6.1, b)); or
- to the integral antenna (clause 8.6.1, c)).

- b) if possible, the measurement shall be made with the transmitter unmodulated. If this is not possible, the transmitter shall be modulated by the normal test signal D-M2, D-M4 as appropriate (clause 7.3). If possible the modulation should be continuous for the duration of the measurement;

The resolution bandwidth of the measuring instrument shall be the smallest bandwidth available which is greater than the spectral width of the spurious component being measured. This shall be considered to be achieved when the next highest bandwidth causes less than 1 dB increase in amplitude.

The conditions used in the relevant measurements shall be recorded in test reports.

- c) the radiation of any spurious components shall be detected by the test antenna and receiver, over the frequency range 30 MHz to 4 GHz, except for the channel on which the transmitter is intended to operate and its adjacent channels;
- d) at each frequency at which a component is detected, the sample shall be rotated to obtain maximum response and the effective radiated power of that component determined by a substitution measurement, using the measurement arrangement of figure 11;

The value of the effective radiated power of that component shall be recorded.

- e) the measurements shall be repeated with the test antenna in the orthogonal polarization plane;
- f) the measurements shall be repeated with the transmitter in the "stand-by" position.

The limit(s) corresponding to this parameter can be found in clause 5.1.5.

8.6.3.2 Equipment measured as non-constant envelope modulation equipment

The measurement procedure shall be as follows:

- a) on a test site, fulfilling the requirements of annex A, the sample shall be placed at the specified height on the support;

The transmitter shall be operated at the carrier power as specified under clause 8.2, delivered to:

- an artificial antenna (clause 7.7) for equipment having an external antenna connector (clause 8.6.1, b)); or
- to the integral antenna (clause 8.6.1, c)).

- b) if possible, the measurement shall be made with the transmitter unmodulated. If this is not possible, the transmitter shall be modulated by the normal test signal, D-M5 or D-M7 as appropriate (clause 7.3). If possible the modulation should be continuous for the duration of the measurement;

As a general rule, the resolution bandwidth of the measuring receiver should be equal to the reference bandwidth as given in clause 5.1.5 (table 3 b)).

"To improve measurement accuracy, sensitivity and efficiency, the resolution bandwidth can be different from the reference bandwidth. When the resolution bandwidth is smaller than the reference bandwidth, the result should be integrated over the reference bandwidth. When the resolution bandwidth is greater than the reference bandwidth, the result for broadband spurious emissions should be normalized to the bandwidth ratio. For discrete spur, normalization is not applicable, while integration over the reference bandwidth is still applicable" (extract from CEPT/ERC/REC 74-01E, recommend 4, page 5 [9]).

The conditions used in the relevant measurements shall be recorded in test reports.

- c) the radiation of any spurious components shall be detected by the test antenna and receiver, over the frequency range 30 MHz to 4 GHz, except for the channel on which the transmitter is intended to operate and its adjacent channels;
- d) at each frequency at which a component is detected, the sample shall be rotated to obtain maximum response and the effective radiated power of that component determined by a substitution measurement, using the measurement arrangement of figure 11;

The value of the effective radiated power of that component shall be recorded.

- e) the measurements shall be repeated with the test antenna in the orthogonal polarization plane;
- f) the measurements shall be repeated with the transmitter in the "stand-by" position.

The limit(s) corresponding to this parameter can be found in clause 5.1.5.

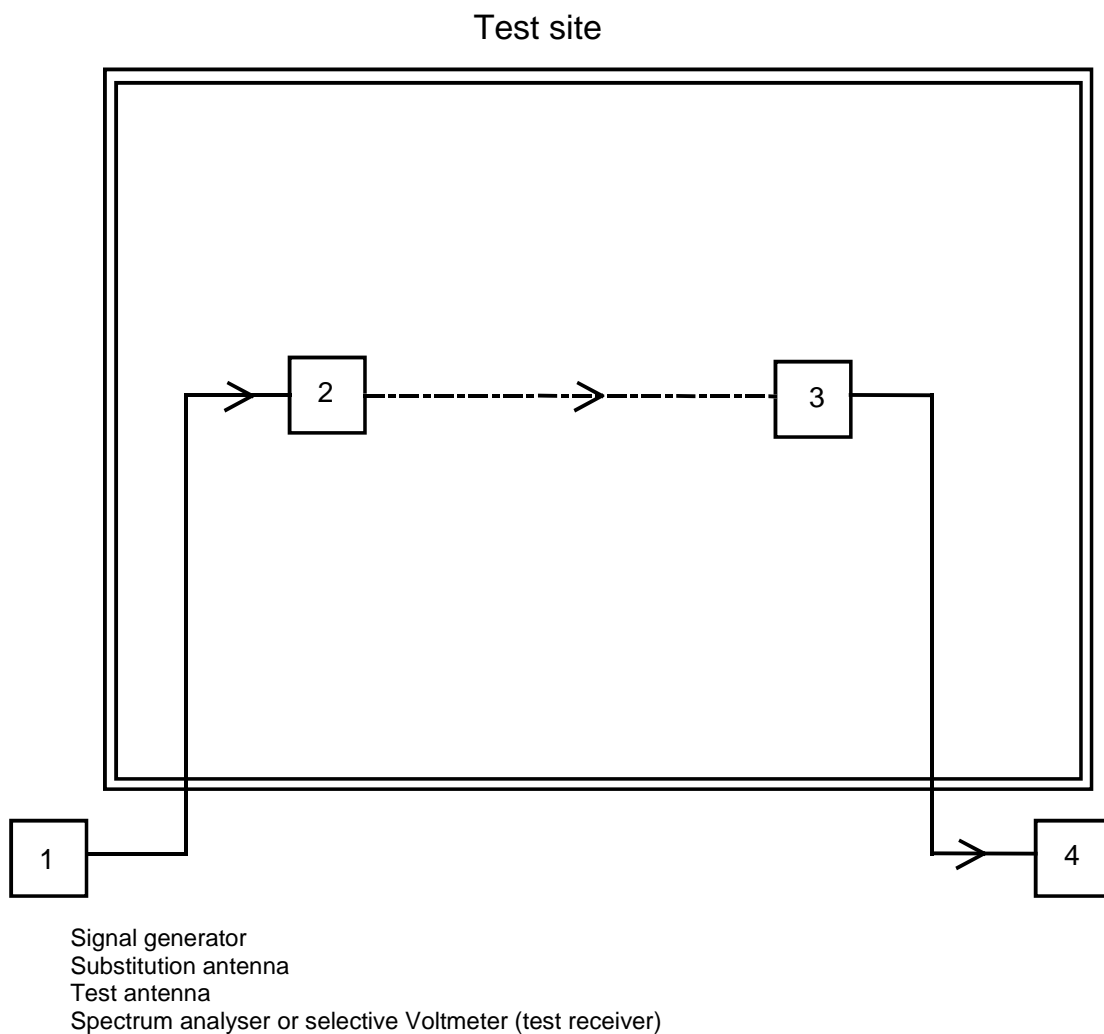

Figure 11: Measurement arrangement

8.7 Intermodulation attenuation

This requirement applies only to transmitters to be used in base stations.

8.7.1 Definition

For the purpose of the present document the intermodulation attenuation is a measure of the capability of a transmitter to inhibit the generation of signals in its non-linear elements caused by the presence of the carrier and an interfering signal entering the transmitter via its antenna.

8.7.2 Method of measurement

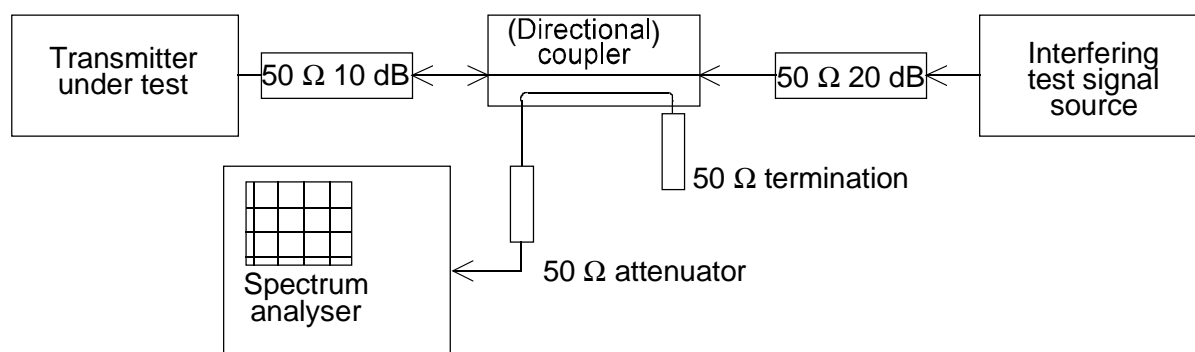

Figure 12: Measurement arrangement

The measurement arrangement shown in figure 12 should be used.

The transmitter shall be connected to a 50 Ω 10 dB power attenuator and via a (directional) coupler to a spectrum analyser. An additional attenuator may be required between the directional coupler and the spectrum analyser to avoid overloading.

In order to reduce the influence of mismatch errors it is important that the 10 dB power attenuator is coupled to the transmitter under test with the shortest possible connection.

The interfering test signal source may be either a transmitter providing the same power output as the transmitter under test and be of a similar type, or a signal generator and a linear power amplifier capable of delivering the same output power as the transmitter under test.

The (directional) coupler shall have an insertion loss of less than 1 dB. If a directional coupler is used, it shall have a sufficient bandwidth and a directivity of at least 20 dB.

The transmitter under test and the test signal source shall be physically separated in such a way that the measurement is not influenced by direct radiation.

The transmitter under test shall be unmodulated and the spectrum analyser adjusted to give a maximum indication with a frequency scan width of 500 kHz.

The interfering test signal source shall be unmodulated and the frequency shall be within 50 kHz to 100 kHz above the frequency of the transmitter under test.

The frequency shall be chosen in such a way that the intermodulation components to be measured do not coincide with other spurious components. The power output of the interfering test signal source shall be adjusted to the carrier power level of the transmitter under test by the use of a power meter.

The intermodulation component shall be measured by direct observation on the spectrum analyser of the ratio of the largest third order intermodulation component with respect to the carrier.

This value shall be recorded.

This measurement shall be repeated with the interfering test signal source at a frequency within 50 kHz to 100 kHz below the frequency of the transmitter under test.

The intermodulation attenuation of the equipment under test shall be expressed as the lower of the two values recorded in above.

The limit(s) corresponding to this parameter can be found in clause 5.1.6.

8.8 Transmitter attack time

This measurement does not apply to transmitters intended for continuous transmission only.

8.8.1 Definition

The transmitter attack time (t_a) is the time which elapses between the initiation of the "transmitter on" function ($T_{x_{on}}$, see definitions in clause 8.10.1) and:

- a) the moment when the transmitter output power has reached a level 1 dB below or 1,5 dB above the steady state power (P_c) and maintains a level within +1,5 dB/-1 dB from P_c thereafter as seen on the measuring equipment or in the plot of power as a function of time; or
- b) the moment after which the frequency of the carrier always remains within ± 1 kHz of its steady state frequency, F_c , as seen on the measuring equipment or the plot of frequency as a function of time;

whichever occurs later (clause 8.10, figures 13 and 14).

The measured value of t_a is t_{am} ; its limit is t_{al} .

The choice of conditions for b), above, is made in order to make the method of measurement easier to perform and to have good repeatability. It is expected that under these conditions, in the worst case, the frequency of the carrier will be within the frequency tolerance of the steady state, df_c , a few ms after the end of the attack time as defined in b) above.

8.8.2 Method of measurement

For the test arrangement see clause 8.10.3.2, figure 16.

The measurement procedure shall be as follows:

- a) the transmitter is connected to a RF detector and to a test discriminator via a matched test load. The attenuation of the test load shall be chosen in such a way that the input of the test discriminator is protected against overload and the limiter amplifier of the test discriminator operates correctly in the limiting range as soon as the transmitter carrier power (before attenuation) exceeds 1 mW. A dual trace storage oscilloscope (or a transient recorder) records the amplitude transient from the detector on a logarithmic scale and the frequency transient from the discriminator;

A trigger device may be required to ensure that the start of the sweep of the oscilloscope time base occurs at the instant at which the "transmitter on" function is initiated. The measuring arrangement is shown in figure 16 of clause 8.10.

A spectrum analyser and a test discriminator/storage oscilloscope can also be used.

- b) the traces of the oscilloscope shall be calibrated in power and frequency (y-axes) and in time (x-axis), using the signal generator;
- c) the transmitter attack time shall be measured by direct reading on the oscilloscope while the transmitter is preferably unmodulated. If this is not possible, and only in case of equipment measured as non-constant envelope modulation equipment, the transmitter shall be modulated by the normal test signal C1 (clause 7.3).

The limit(s) corresponding to this parameter can be found in clause 5.1.7.

8.9 Transmitter release time

This measurement does not apply to transmitters intended for continuous transmission only.

8.9.1 Definition

The transmitter release time (t_r) is the time which elapses between the initiation of the "transmitter off" function ($T_{x_{off}}$, see definitions in clause 8.10.1) and the moment when the transmitter output power has reduced to a level 50 dB below the steady state power (P_c) and remains below this level thereafter as seen on the measuring equipment or in the plot of power as a function of time (clause 8.10, figure 16).

The measured value of t_r is t_{rm} ; its limit is t_{rl} .

8.9.2 Method of measurement

For the test arrangement see clause 8.10.3.2, figure 16.

The measurement procedure shall be as follows:

- a) the transmitter is connected to a RF detector and to a test discriminator via a matched power attenuator. Its attenuation shall be chosen in such a way that the input of the test discriminator is protected against overload and that the limiter amplifier of the test discriminator operates correctly in the limiting range as long as the transmitter carrier power (before attenuation) exceeds 1 mW. A dual trace storage oscilloscope (or a transient recorder) records the amplitude transient from the detector on a logarithmic scale and the frequency transient from the discriminator. A trigger device may be required to ensure that the start of the sweep of the oscilloscope timebase occurs the instant at which the "transmitter off" function is initiated. If the transmitter possesses an automatic powering down facility (e.g. in the case of fixed length message transmission), it may replace the trigger device for starting the sweep of the oscilloscope. The measuring arrangement is shown in figure 16 of clause 8.10;

A spectrum analyser and a test discriminator/storage oscilloscope can also be used.

- b) the traces of the oscilloscope shall be calibrated in power and frequency (y-axes) and in time (x-axis) by replacing the transmitter and test load by the signal generator;
- c) the transmitter release time shall be measured by direct reading on the oscilloscope while the transmitter is preferably unmodulated. If this is not possible, and only in case of equipment measured as non-constant envelope modulation equipment, the transmitter shall be modulated by the normal test signal C1 (clause 7.3).

The limit(s) corresponding to this parameter can be found in clause 5.1.8.

8.10 Transient behaviour of the transmitter

Limitations of the transmitter attack and release times (clauses 8.8 and 8.9) are intended to improve the spectrum efficiency. The attack and release times can also be used to allow the definition of the timings in the protocols.

The measurements of transient behaviour are intended to ensure that the transmitter will not cause harmful interference in the other channels when the operating frequency is outside the tolerance of the steady state df_c .

In case of equipment measured as constant envelope angle modulation equipment, the method of measurement includes:

- the drawing of plots of "carrier power as a function of time" and "carrier frequency as a function of time";
- the evaluation of the slopes of those plots between predetermined points;
- the measurement of the transient power in the adjacent channels.

In case of equipment measured as non-constant envelope modulation equipment, the method of measurement includes:

- the drawing of plots of "carrier power as a function of time" and "carrier frequency as a function of time";
- the evaluation of the slopes of those plots between predetermined points;
- the measurement of the transient power in the adjacent channels, in the alternates channels and at ± 100 kHz and ± 1 MHz offsets from channel centre frequency.

8.10.1 Definitions

The transient behaviour of the transmitter is defined as the time-dependency of transmitter frequency, power and spectrum when the RF output power is switched on and off.

The following powers, frequencies, frequency tolerances and transient times are specified:

P₀: rated power;

P_c: steady state power;

- P_a**: adjacent channel transient power. It is transient power falling into the adjacent channels due to switching the transmitter on and off (clause 8.10.3.3);
- F_o**: nominal carrier frequency;
- F_c**: steady state carrier frequency;
- df**: frequency difference (relative to F_c) or frequency error (absolute) (clause 8.1.1), of the transmitter;
- df_e**: limit of the frequency error (df) in the steady state (clause 5.1.1);
- df₀**: limit of the frequency difference (df) equal to 1 kHz. If it is impossible to switch off the transmitter modulation one half channel separation is added;
- df_c**: limit of the frequency difference (df) during the transient, equal to one half channel separation; while the frequency difference is less than df_c, the carrier frequency remains within the boundaries of the allocated channel. If it is impossible to switch off the transmitter modulation another half channel separation is added;
- Tx_{on}**: time at which the final irrevocable logic decision to power on the transmitter is taken.

If an access point is unavailable then the time after which the carrier power exceeds (P_c - 50 dB) may be taken. This fact shall be recorded in test reports.

The power starts to rise somewhere between Tx_{on} and t_{on} (RF-power on):

- t_{on}**: time when the carrier power, measured at the transmitter output, exceeds P_c - 30 dB;
- t_p**: period of time starting at t_{on} and finishing when the power reaches P_c - 6dB;
- t_a**: transmitter attack time as defined in clause 8.8;
- t_{am}**: measured value of t_a;
- t_{al}**: limit of t_{am} as given in clause 5.1.7;

Tx_{off}: time at which the final irrevocable logic decision to power off the transmitter is taken.

If an access point is unavailable then the time after which the carrier power remains below (P_c - 3 dB) may be taken. This fact shall be recorded in test reports.

The power starts to decrease somewhere between Tx_{off} and the moment when P_c - 6 dB is reached (RF-power off):

- t_{off}**: time when the carrier power falls below P_c - 30 dB;
- t_d**: period of time starting when the power falls below P_c - 6 dB and finishing at t_{off};
- t_r**: transmitter release time as defined in clause 8.9 (after the end of the release time, the power remains below P_c - 50 dB);
- t_{rm}**: measured value of t_r;
- t_{rl}**: limit of t_{rm} as given in clause 5.1.8.

If use is made of a synthesizer and/or a Phase Locked Loop (PLL) system, for determining the transmitter frequency, then the transmitter shall be inhibited when synchronization is absent or in the case of PLL, when the loop system is not locked.

8.10.2 Timings, frequencies and powers

Figures 13, 14 and 15 represent the timings, frequencies and powers as defined in clauses 8.8.1, 8.9.1 and 8.10.1.

The corresponding limits are given in clauses 5.1.7, 5.1.8 and 5.1.9.

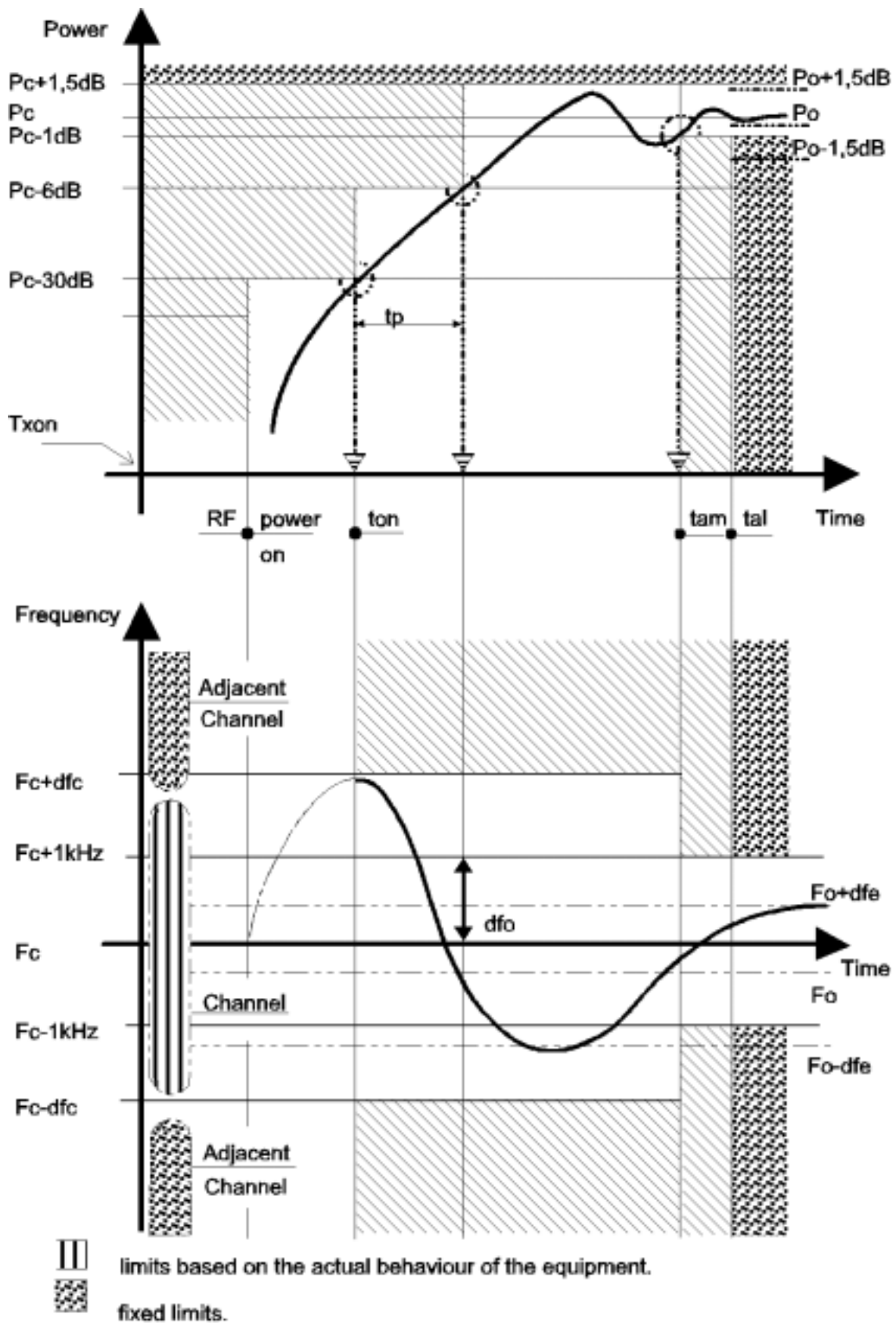

Figure 13: Transmitter attack time according to clause 8.8.1 a) and transient behaviour during switch-on (case where the attack time is given by the behaviour of the power rise)

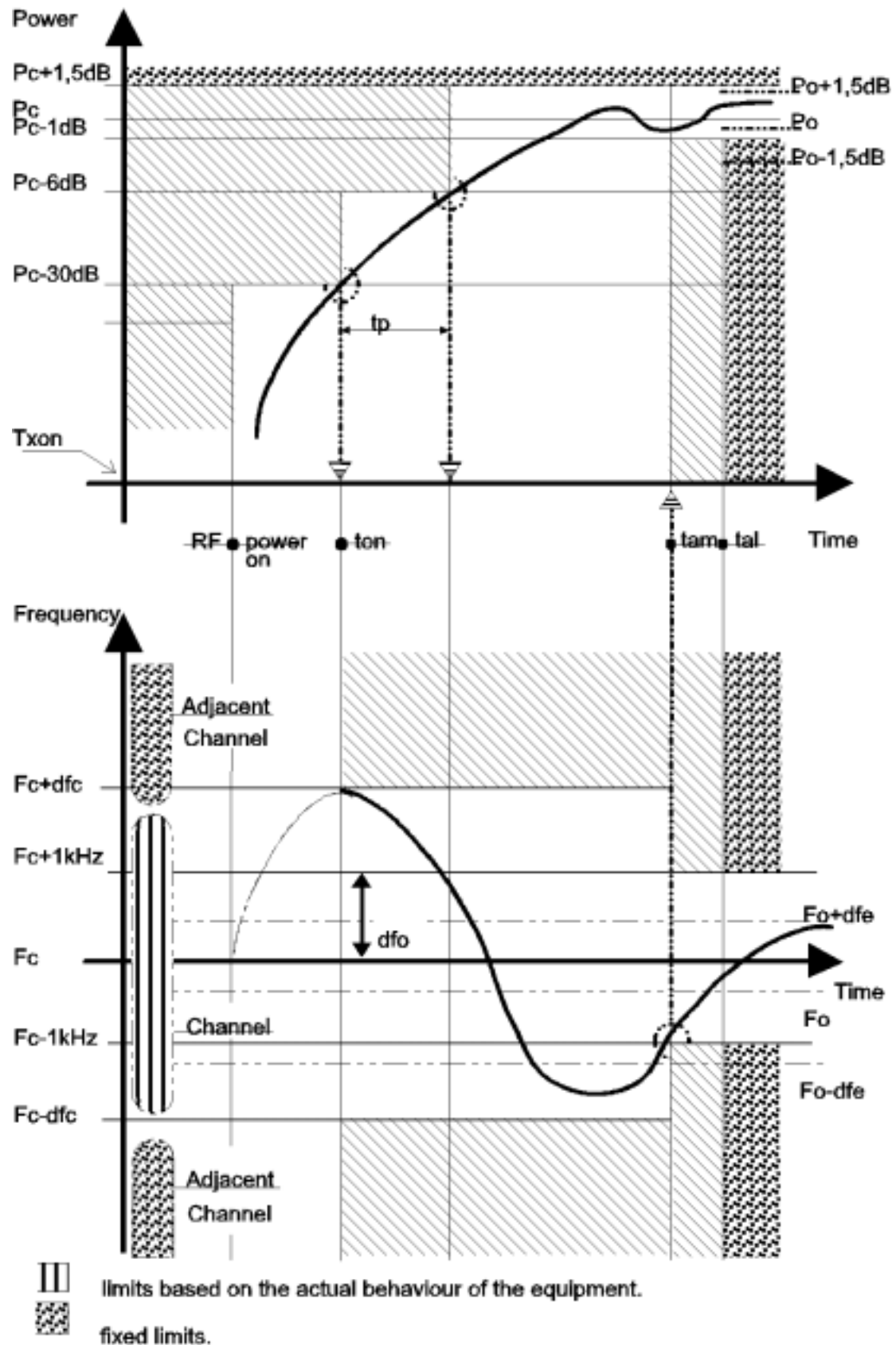

Figure 14: Transmitter attack time according to clause 8.8.1 b) and transient behaviour during switch-on (case where the attack time is given by the behaviour of the frequency)

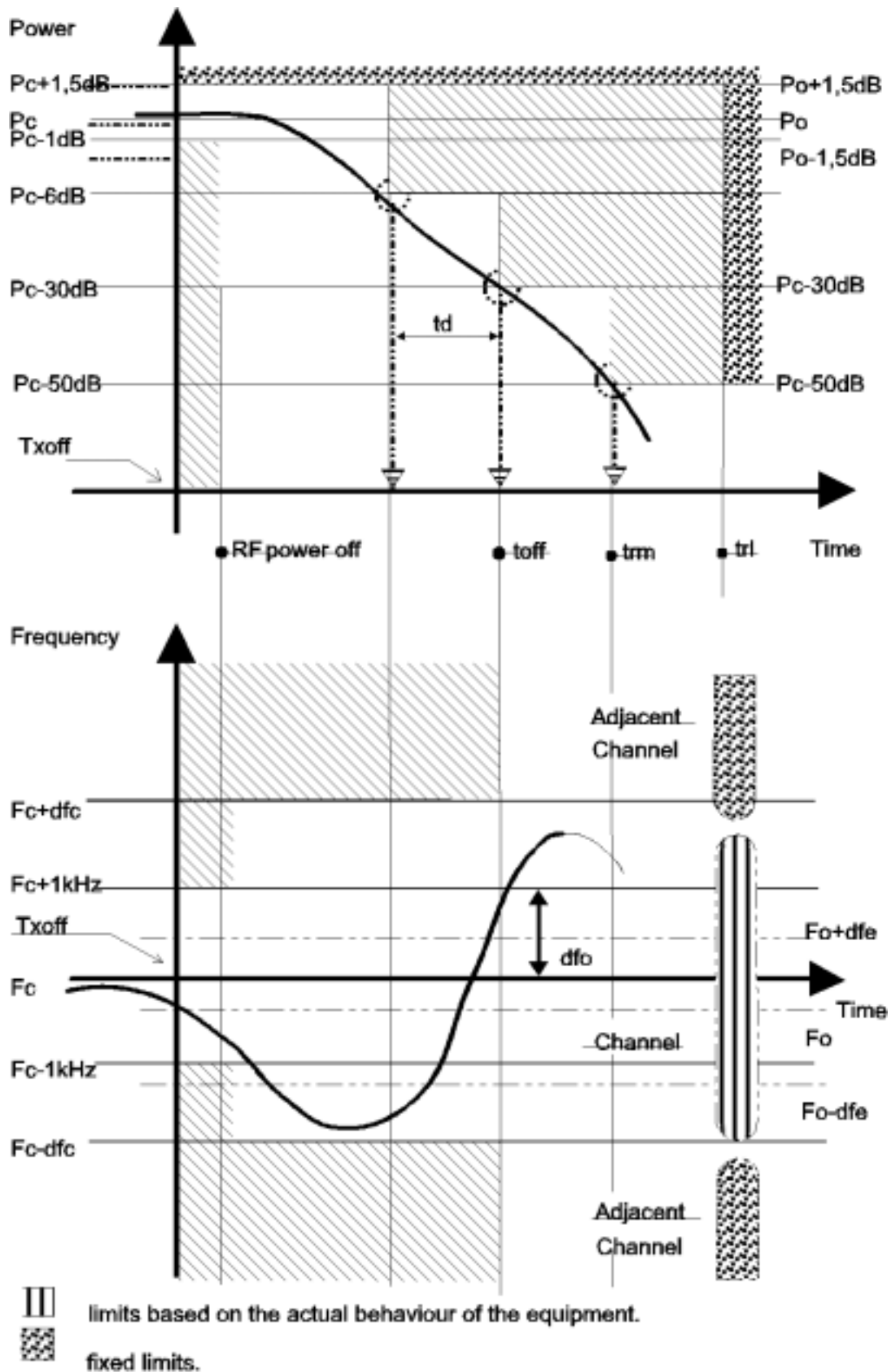

Figure 15: Transmitter release time according to clause 8.9.1 and transient behaviour, during switch-off

8.10.3 Methods of measurement

The transient timings (switch on/switch off cases) and the frequency differences occurring during these periods of time can be measured by means of a spectrum analyser and a test discriminator which meets the requirements indicated in clause 8.10.3.2. The corresponding limits are given in clause 5.1.9.1.

The power, impairing the operation on the adjacent channels, can be measured using an appropriate transient power measuring device which meets the requirements of clause 8.10.3.4. The corresponding limits are given in clause 5.1.9.2.

8.10.3.1 Time domain measurements of power and frequency

The measurement shall be performed with the transmitter unmodulated if possible. If this is not possible, and only in case of equipment measured as non-constant envelope modulation equipment, the transmitter shall be modulated by the normal test signal C1 (clause 7.3). If the transmitter cannot be operated unmodulated, the measurement shall be performed with modulation and this fact shall be recorded in test reports.

The transmitter shall be connected to the test set-up as shown in figure 16.

The calibration of the test set-up shall be checked. The transmitter output is connected to the input of the spectrum analyser and test discriminator via power attenuators and a power splitter.

The attenuation of the power attenuators shall be chosen in such a way that the input of the test equipment is protected against overload and that the limiter amplifier of the test discriminator operates correctly in the limiting range when the power conditions of clause 8.10.1 are reached.

The spectrum analyser is set to measure and display power as a function of time ("zero span mode").

The test discriminator shall be calibrated. This can be done by feeding RF voltages from a signal generator with defined frequency differences from the nominal frequency of the transmitter.

By appropriate means, a triggering pulse is generated for the test equipment when the $T_{x_{on}}$ function or the $T_{x_{off}}$ function are activated.

The "RF power on" and the "RF power off" can be monitored.

The voltage occurring at the test discriminator output shall be recorded as a function of time in correspondence with the power level on a storage device or a transient recorder. This voltage is a measure of the frequency difference. The elapsed periods of time during the frequency transient can be measured using the time base of the storage device. The output of the test discriminator is valid only after t_{on} and before t_{off} .

A cross over impulse (noise to signal) of the instrument, if any, shall be disregarded.

8.10.3.2 Test arrangement and characteristics of the test discriminator

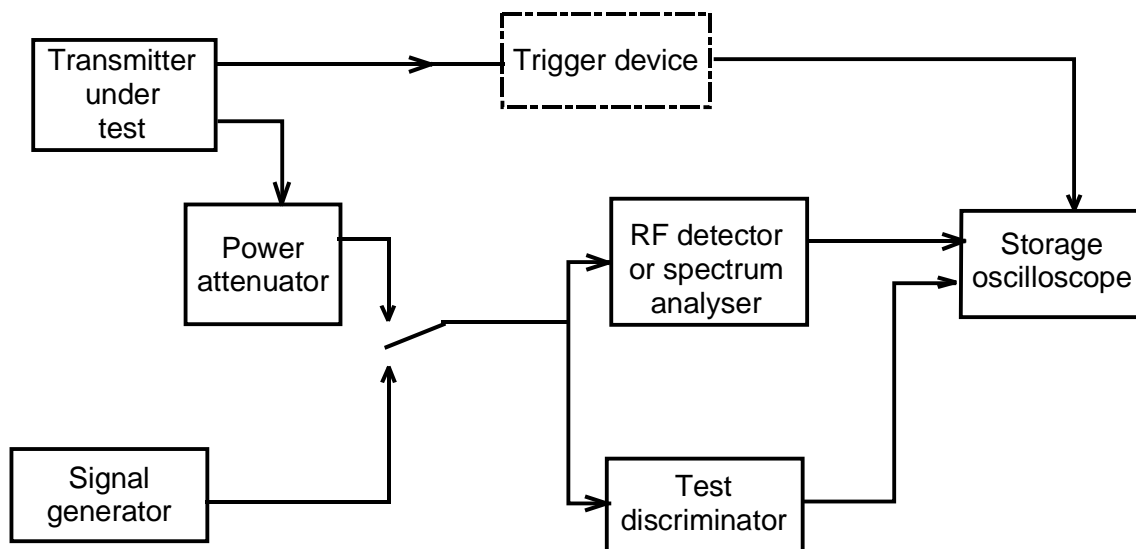

Figure 16: Test arrangement for transient behaviour of transmitter power and frequency, including transmitter attack and release time

The test discriminator may consist of a mixer and a local oscillator (providing the auxiliary frequency) used to convert the transmitter frequency to be measured into the frequency fed to the (broadband) limiter amplifier and the associated broadband discriminator:

- the test discriminator shall be sensitive enough to measure input signals down to $P_c - 30$ dB;
- the test discriminator shall be fast enough to display the frequency deviations (approximately 100 kHz/100 ms);
- the test discriminator output shall be dc coupled.

8.10.3.3 Adjacent channel transient power measurements

The transmitter under test shall be connected via the power attenuator to the "adjacent channel transient power measuring device" as described in clause 8.10.3.4, so that the level at its input is suitable, e.g. between 0 dBm and -10 dBm when the transmitter power is P_c .

8.10.3.3.1 Definition

Transient power is the power falling into adjacent (or other) spectrum due to the switching on or off of a transmitter.

8.10.3.3.2 Equipment measured as constant envelope angle modulation equipment

The measurement shall be performed with the transmitter unmodulated if possible. If the transmitter cannot be operated unmodulated, the measurement shall be performed with modulation and this fact shall be recorded in test reports.

The measurement procedure shall be as follows:

- a) the transmitter shall be operated at the maximum rated carrier power level, under normal test conditions (clause 6.3);
- b) the tuning of the "transient power measuring device" shall be adjusted so that a maximum response is obtained. This is the 0 dBc reference level;

The transmitter shall then be switched off.

- c) the tuning of the "transient power measuring device" shall be adjusted away from the carrier so that its -6 dB response nearest to the transmitter carrier frequency is located at a displacement from the nominal carrier frequency as given in table 8 a);

Table 8 a): Frequency displacement

Channel separation (kHz)	Displacement (kHz)
12,5	8,25
20	13
25	17

- d) the transmitter shall be switched on;
- e) the spectrum analyser shall be used to record the envelope of the transient power as a function of time (approximately 50 ms duration). The peak envelope transient power shall be noted in dBc;
- f) the transmitter shall be switched off;
- g) the spectrum analyser shall be used to record the envelope of the transient power as a function of time (approximately 50 ms duration). The peak envelope transient power shall be noted in dBc;
- h) steps d) to g) shall be repeated five times and the highest response during "switch-on" and "switch-off" conditions shall be recorded;
- i) steps c) to h) shall be repeated with the "transient power measuring device" tuned to the other side of the carrier;
- j) the adjacent channel transient power during the attack and release times is the dBc value corresponding to the highest of the values recorded in step h).

This value shall be recorded.

8.10.3.3.3 Equipment measured as non-constant envelope modulation equipment

The transmitter shall be modulated by the normal test signal, D-M5 or D-M7 as appropriate (clause 7.3).

For constant envelope modulation schemes it is not required to apply modulation. The modulation used, if any, shall be recorded in the test report.

The measurement procedure shall be as follows:

- a) the transmitter shall be operated at the maximum rated carrier power level, under normal test conditions (clause 6.3);
- b) the tuning of the "transient power measuring device" shall be adjusted so that a maximum response is obtained. This is the 0 dBc reference level;

The transmitter shall then be switched off.

- c) the tuning of the "transient power measuring device" shall be adjusted away from the carrier so that its -6 dB response nearest to the transmitter carrier frequency is located at a displacement from the nominal carrier frequency as given in table 8 b);

Table 8 b): Frequency displacements

	Adjacent Channel Measurement	Alternate Channel Measurement	100 kHz Measurement	1 MHz Measurement
Channel separation (kHz)	Displacement (kHz)	Displacement (kHz)	Displacement (kHz)	Displacement (MHz)
12,5	8,25	20,75	100	1
20	13	33	100	1
25	17	42	100	1

- d) the transmitter shall be switched on;
- e) the spectrum analyser shall be used to record the envelope of the transient power as a function of time (approximately 50 ms duration). The peak envelope transient power shall be noted in dBc;

- f) the transmitter shall be switched off;
- g) the spectrum analyser shall be used to record the envelope of the transient power as a function of time (approximately 50 ms duration). The peak envelope transient power shall be noted in dBc;
- h) steps d) to g) shall be repeated five times and the highest response during "switch-on" and "switch-off" conditions shall be recorded;
- i) steps c) to h) shall be repeated with the "transient power measuring device" tuned to the other side of the carrier;
- j) steps c) to i) shall be repeated with the tuning of the "transient power measuring device" adjusted away from the centre of the channel so that its -6 dB response nearest to the transmitter channel centre frequency is located successively at displacements from the nominal carrier frequency as given in table 8 b);
- k) the adjacent channel transient power during the attack and release times is the dBc value corresponding to the highest of the values recorded in step h).

This value shall be recorded.

8.10.3.4 Characteristics of the adjacent channel transient power measuring device

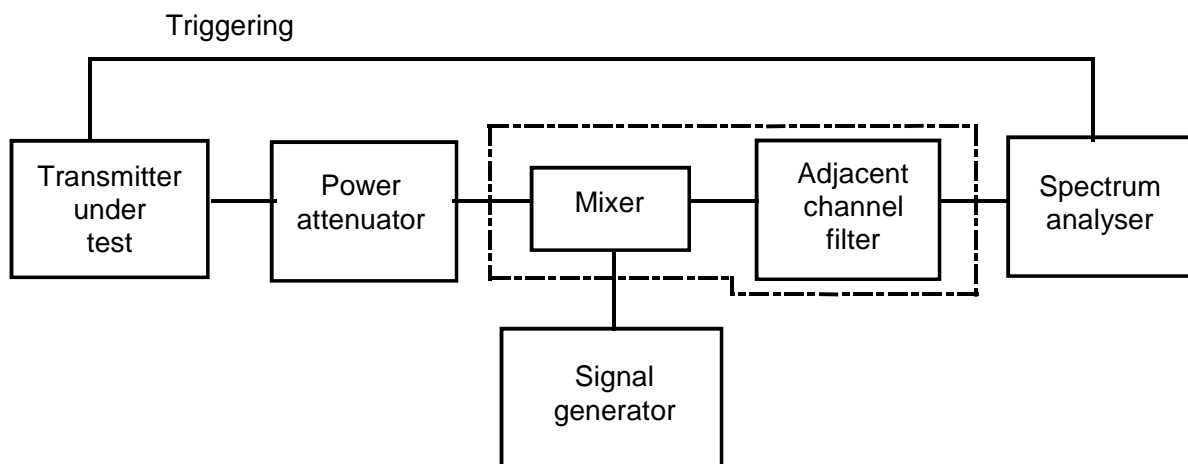

Figure 17: Adjacent channel transient power measuring device measurement arrangement

The adjacent channel transient power measuring device may be as follows:

mixer:	50 Ω balanced diode mixer; with an appropriate local oscillator level, for example +7 dBm;
adjacent channel filter:	matched to 50 Ω (clause B.1.1);
spectrum analyser:	- 100 kHz bandwidth - peak detection, or power/time measurement provision.

9 Methods of measurement for receiver parameters

9.1 Maximum usable sensitivity (data or messages, conducted)

9.1.1 Definition

The maximum usable sensitivity (data or messages, conducted) is the minimum level of signal (emf) at the receiver input, produced by a carrier at the nominal frequency of the receiver, modulated with the normal test signal (clause 7.3), which will, without interference, produce after demodulation a data signal with a specified bit error ratio or a specified successful message ratio. The specified bit error ratio is 10^{-2} . The specified successful message ratio is 80 %.

9.1.2 Method of measurement with continuous bit streams

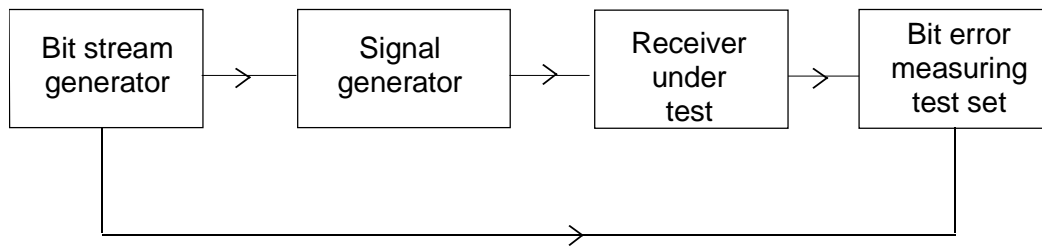

Figure 18: Measurement arrangement

The measurement procedure shall be as follows:

- an input signal with a frequency equal to the nominal frequency of the receiver, modulated by the normal test signal D-M2 or D-M5, as appropriate (clause 7.3), shall be applied to the receiver input terminals;
- the bit pattern of the modulating signal shall be compared to the bit pattern obtained from the receiver after demodulation (see also clause 7.9.2 and figure 2B);
- the emf of the input signal to the receiver is adjusted until the bit error ratio is 10^{-2} or better. (When the value of 10^{-2} cannot be reached exactly, this shall be taken into account in the evaluation of the measurement uncertainty (TR 100 028 [4]));
- the maximum usable sensitivity is the emf of the input signal to the receiver;
This value shall be recorded.
- the measurement shall be repeated under extreme test conditions (clauses 6.4.1 and 6.4.2 applied simultaneously).

The limit(s) corresponding to this parameter can be found in clause 5.2.1.

9.1.3 Method of measurement with messages

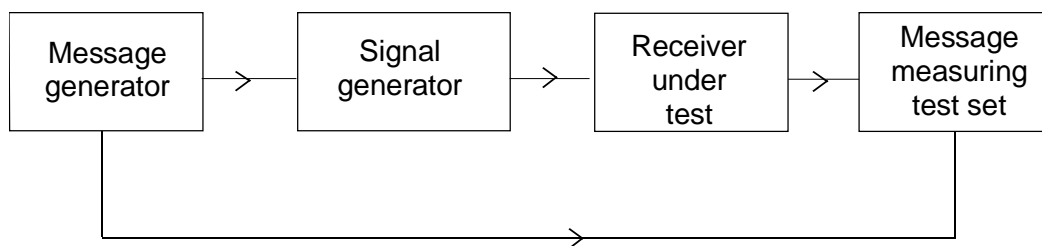

Figure 19: Measurement arrangement

The measurement procedure shall be as follows:

- an input signal with a frequency equal to the nominal frequency of the receiver, having normal test modulation (clause 7.3), in accordance with the instructions of the manufacturer (and accepted by the testing laboratory), shall be applied to the receiver input terminals;
- the level of this signal shall be such that a successful message ratio of less than 10 % is obtained;
- the normal test signal (clause 7.3) shall then be transmitted repeatedly whilst observing in each case whether or not a message is successfully received;

The level of the input signal shall be increased by 2 dB for each occasion that a message is not successfully received.

The procedure shall be continued until three consecutive messages are successfully received.

The level of the input signal shall then be noted.

- d) the level of the input signal shall be reduced by 1 dB and the new value noted;

The normal test signal (clause 7.3) shall then be transmitted 20 times. In each case, if a message is not successfully received the level of the input signal shall be increased by 1 dB and the new value noted.

If a message is successfully received, the level of the input signal shall not be changed until three consecutive messages have been successfully received. In this case, the level of the input signal shall be reduced by 1 dB and the new value noted.

No level of the input signal shall be noted unless preceded by a change in level.

- e) the maximum usable sensitivity is the average of the values noted in steps c) and d) (which provides the level corresponding to the successful message ratio of 80 %);

This value shall be recorded.

- f) the measurement shall be repeated under extreme test conditions (clauses 6.4.1 and 6.4.2 applied simultaneously).

The limit(s) corresponding to this parameter can be found in clause 5.2.1.

9.2 Average usable sensitivity (data or messages, field strength)

This measurement applies only to equipment without an external antenna connector.

For the definition and the method of measurement, see EN 300 390 [2], clause 9.1.

The limit(s) corresponding to this parameter can be found in clause 5.2.1 of EN 300 390 [2], as stated in clause 5.2.2 of the present document.

9.3 Level of the wanted signal for the degradation measurements (data or messages)

Degradation measurements are those measurements which are made on the receiver to establish the degradation of the performance of the receiver due to the presence of (an) unwanted (interfering) signal(s).

The level of the wanted signal for the degradation measurements, under normal test conditions (clause 6.3), shall be an emf of +6 dB μ V. It is 3 dB above the limit of the maximum usable sensitivity (data or messages, conducted).

9.4 Error behaviour at high input levels

9.4.1 Definition

The error behaviour (performance) at high input levels (noise free operation) is defined by the bit error ratio (continuous bit stream) or by the number of messages lost or corrupted when the level of the wanted signal is significantly above the maximum usable sensitivity.

9.4.2 Method of measurement with continuous bit streams

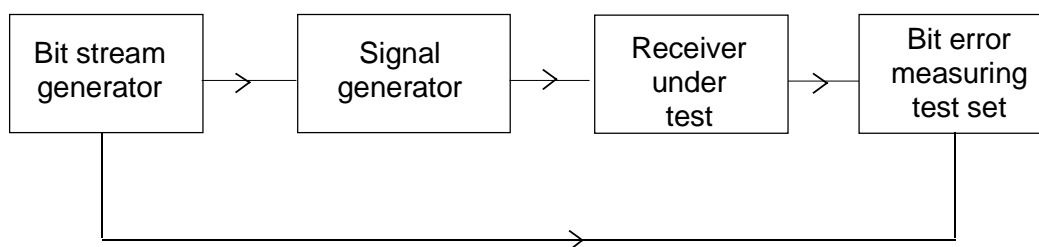

Figure 20: Measurement arrangement

The measurement procedure shall be as follows:

- a) an input signal with a frequency equal to the nominal frequency of the receiver, modulated by the normal test signal D-M2 or D-M5, as appropriate (clause 7.3), shall be applied to the receiver input terminals;
- b) the bit pattern of the modulating signal shall be compared to the bit pattern obtained from the receiver after demodulation (see also clause 7.9.2 and figure 2B);
- c) the level of the input signal shall be adjusted to a level which is 30 dB above the level of the wanted signal for the degradation measurements (clause 9.3);
- d) the number of errors that occur at the data output terminals or at a special measuring terminal of the receiver, during a period of 3 minutes, shall be counted;

This value shall be recorded.

- e) the measurement shall be repeated with the level of the input signal of the receiver adjusted to a level which is 100 dB above the level of the wanted signal for the degradation measurements (clause 9.3).

The limit(s) corresponding to this parameter can be found in clause 5.2.3.

9.4.3 Method of measurement with messages

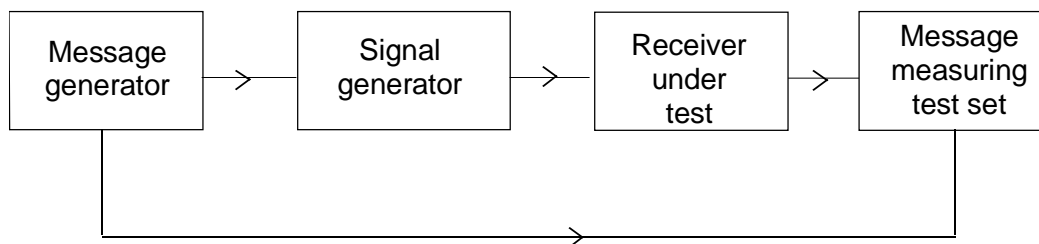

Figure 21: Measurement arrangement

The measurement procedure shall be as follows:

- a) an input signal with a frequency equal to the nominal frequency of the receiver, having normal test modulation (clause 7.3), in accordance with the instructions of the manufacturer (and accepted by the testing laboratory), shall be applied to the receiver input terminals;
- b) the level of the input signal shall be adjusted to a level which is 30 dB above the level of the wanted signal for the degradation measurements (clause 9.3);
- c) the normal test signal (clause 7.3) shall then be transmitted 100 times whilst observing in each case whether or not a message is successfully received;
- d) the number of messages not successfully received shall be recorded;
- e) the measurement shall be repeated with the input signal of the receiver at a level which is 100 dB above the wanted signal for the degradation measurements (clause 9.3).

The limit(s) corresponding to this parameter can be found in clause 5.2.3.

9.5 Co-channel rejection

9.5.1 Definition

The co-channel rejection is a measure of the capability of the receiver to receive a wanted modulated signal without exceeding a given degradation due the presence of an unwanted modulated signal, both signals being at the nominal frequency of the receiver.

9.5.2 Method of measurement with continuous bit streams

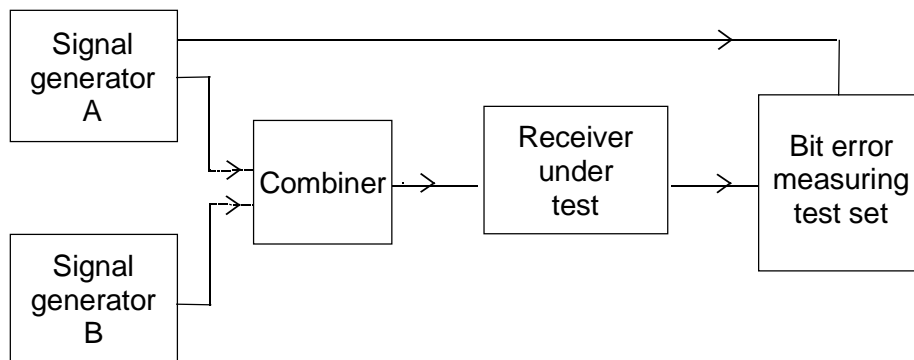

Figure 22: Measurement arrangement

The measurement procedure shall be as follows:

- a) two signal generators, A and B, shall be connected to the receiver via a combining network (clause 7.1);

The wanted signal, provided by signal generator A, shall be at the nominal frequency of the receiver and shall be modulated by the normal test signal D-M2 or D-M5, as appropriate (clause 7.3).

The unwanted signal, provided by signal generator B, shall be modulated with signal A-M3 (clause 7.3).

Both input signals shall be at the nominal frequency of the receiver under test.

- b) initially, signal generator B (unwanted signal) shall be switched off (maintaining the output impedance);

The level of the wanted signal from generator A shall be adjusted to a level which is 3 dB above the level of the limit of the maximum usable sensitivity as specified in clause 9.3 (data or messages), at the receiver input terminals (i.e. 6 dB above 1 μ V emf under normal test conditions).

- c) signal generator B shall then be switched on, and the level of the unwanted signal adjusted until a bit error ratio of 10^{-1} or worse is obtained;
- d) the normal test signal D-M2 or D-M5 as appropriate shall be transmitted whilst observing the bit error ratio;
- e) the level of the unwanted signal shall be reduced in steps of 1 dB until a bit error ratio of 10^{-2} or better is obtained. The level of the unwanted signal shall then be noted;
- f) for each frequency of the unwanted signal, the co-channel rejection ratio shall be expressed as the ratio, in dB, of the level of the unwanted signal to the level of the wanted signal, at the receiver input;

This ratio shall be recorded.

- g) the measurement shall be repeated for displacements of the unwanted signal of $\pm 12\%$ of the channel separation;

- h) the co-channel rejection ratio of the equipment under test shall be expressed as the lowest of the three values expressed in dB, calculated in step f);

The value of the co-channel rejection ratio, expressed in dB, is generally negative (therefore, for example, -12 dB is lower than -8 dB).

The limit(s) corresponding to this parameter can be found in clause 5.2.4.

9.5.3 Method of measurement with messages

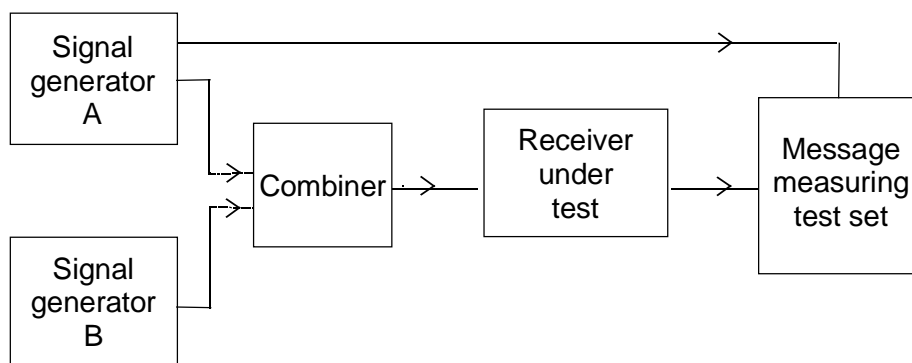

Figure 23: Measurement arrangement

The measurement procedure shall be as follows:

- a) two signal generators, A and B, shall be connected to the receiver via a combining network (clause 7.1);

The wanted signal, provided by signal generator A, shall be at the nominal frequency of the receiver and shall have normal test modulation (clause 7.3).

The unwanted signal, provided by signal generator B, shall be modulated with signal A-M3 (clause 7.3).

Both input signals shall be at the nominal frequency of the receiver.

- b) initially, signal generator B (unwanted signal) shall be switched off (maintaining the output impedance);

The level of the wanted signal from generator A shall be adjusted to a level which is 3 dB above the level of the limit of the maximum usable sensitivity as specified in clause 9.3) (data or messages) at the receiver input terminals (i.e. 6 dB above 1 μ V emf under normal test conditions).

- c) signal generator B shall then be switched on, and the level of the unwanted signal adjusted until a successful message ratio of less than 10 % is obtained;

- d) the normal test signal (clause 7.3) shall then be transmitted repeatedly whilst observing in each case whether or not a message is successfully received;

The level of the unwanted signal shall be reduced by 2 dB for each occasion that a message is not successfully received.

The procedure shall be continued until three consecutive messages are successfully received. The level of the input signal shall then be noted.

- e) the level of the unwanted signal shall be increased by 1 dB and the new value noted;

The normal test signal (clause 7.3) shall then be transmitted 20 times. In each case, if a message is not successfully received the level of the unwanted signal shall be reduced by 1 dB and the new value noted.

If a message is successfully received, the level of the unwanted signal shall not be changed until three consecutive messages have been successfully received. In this case the unwanted signal shall be increased by 1 dB and the new value noted.

No level of the unwanted signal level shall be noted unless preceded by a change in level.

The average of the values noted in steps d) and e) (which provides the level corresponding to the successful message ratio of 80 %) shall be noted.

- f) for each frequency of the unwanted signal, the co-channel rejection ratio shall be expressed as the ratio, in dB, of the average level noted in step e) to the level of the wanted signal, at the receiver input;

This ratio shall be recorded.

- g) the measurement shall be repeated for displacements of the unwanted signal of $\pm 12\%$ of the channel separation;
- h) the co-channel rejection of the equipment under test shall be expressed as the lowest of the three values expressed in dB, recorded in step f);

The value of the co-channel rejection ratio, expressed in dB, is generally negative (therefore, for example, -12 dB is lower than -8 dB).

The limit(s) corresponding to this parameter can be found in clause 5.2.4.

9.6 Adjacent channel selectivity

9.6.1 Definition

The adjacent channel selectivity is a measure of the capability of the receiver to receive a wanted modulated signal without exceeding a given degradation due to the presence of an unwanted signal which differs in frequency from the wanted signal by an amount equal to the adjacent channel separation for which the equipment is intended.

9.6.2 Method of measurement with continuous bit streams

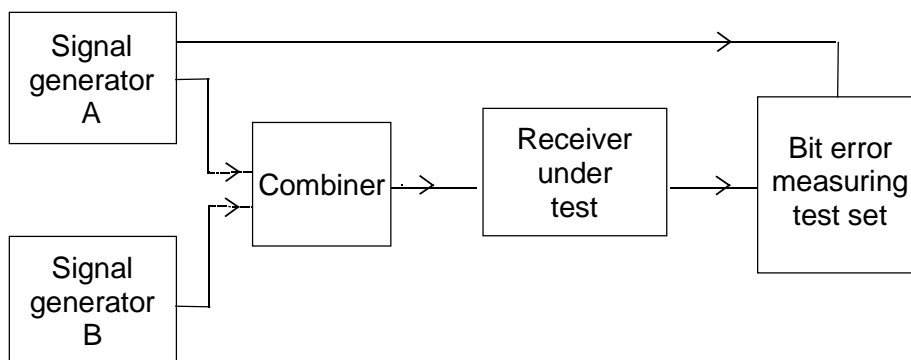

Figure 24: Measurement arrangement

The measurement procedure shall be as follows:

- a) two signal generators, A and B, shall be connected to the receiver via a combining network (clause 7.1);

The wanted signal, provided by signal generator A, shall be at the nominal frequency of the receiver and shall be modulated by the normal test signal D-M2 or D-M5, as appropriate (clause 7.3).

The unwanted signal, provided by signal generator B, shall be modulated with signal A-M3 (clause 7.3) and shall be at the frequency of the channel immediately above that of the wanted signal.

- b) initially, signal generator B (unwanted signal) shall be switched off (maintaining the output impedance);

The level of the wanted signal from generator A shall be adjusted to the level which is 3 dB above the level of the limit of the maximum usable sensitivity as specified in clause 9.3 (data or messages), at the receiver input terminals (i.e. 6 dB above 1 μ V emf under normal test conditions).

- c) signal generator B shall then be switched on, and the level of the unwanted signal adjusted until a bit error ratio of 10^{-1} or worse is obtained;

- d) the normal test signal D-M2 or D-M5 as appropriate shall be transmitted whilst observing the bit error ratio;
- e) the level of the unwanted signal shall be reduced in steps of 1 dB until a bit error ratio of 10^{-2} or better is obtained. The level of the unwanted signal shall then be noted;
- f) for each adjacent channel, the selectivity shall be expressed as the ratio, in dB, of the level of the unwanted signal to the level of the wanted signal, at the receiver input;

This ratio shall be recorded.

- g) the measurement shall be repeated with the unwanted signal at the frequency of the channel below that of the wanted signal;
- h) the adjacent channel selectivity of the equipment under test shall be expressed as the lower of the two values measured in the upper and lower channels nearest to the receiving channel (see step f) above);
- i) the measurement shall be repeated under extreme test conditions (clauses 6.4.1 and 6.4.2 applied simultaneously), using the level of the wanted signal, as specified in clause 9.3 (data or messages), increased by 6 dB.

If analogue measurements according to EN 300 086 [1] have been made before, including adjacent channel selectivity under extreme test conditions, the adjacent channel selectivity (data or messages) shall be measured at normal test conditions only.

NOTE: This is a valid procedure, because the degradation of adjacent channel selectivity at extreme test conditions is known by the analogue measurement results.

The limit(s) corresponding to this parameter can be found in clause 5.2.5.

9.6.3 Method of measurement with messages

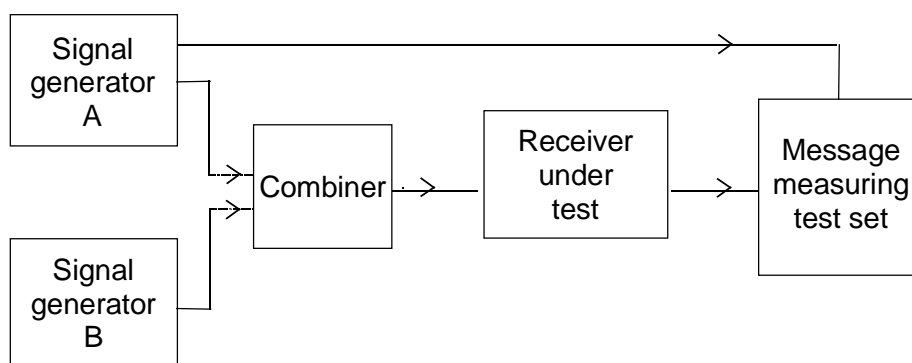

Figure 25: Measurement arrangement

The measurement procedure shall be as follows:

- a) two signal generators, A and B, shall be connected to the receiver via a combining network (clause 7.1);
 The wanted signal, provided by signal generator A, shall be at the nominal frequency of the receiver and shall have normal test modulation (clause 7.3).
 The unwanted signal, provided by signal generator B, shall be modulated with signal A-M3 (clause 7.3) and shall be at the frequency of the channel immediately above that of the wanted signal.
- b) initially, signal generator B (unwanted signal) shall be switched off (maintaining the output impedance).
 The level of the wanted signal from generator A shall be adjusted to the level which is 3 dB above the level of the limit of the maximum usable sensitivity as specified in clause 9.3 (data or messages), at the receiver input terminals (i.e. 6 dB above 1 μ V emf under normal test conditions).
- c) signal generator B shall then be switched on, and the level of the unwanted signal adjusted until a successful message ratio of less than 10 % is obtained;

- d) the normal test signal (clause 7.3) shall then be transmitted repeatedly whilst observing in each case whether or not a message is successfully received;

The level of the unwanted signal shall be reduced by 2 dB for each occasion that a message is not successfully received.

The procedure shall be continued until three consecutive messages are successfully received. The level of the input signal shall then be noted.

- e) the level of the unwanted signal shall be increased by 1 dB and the new value noted;

The normal test signal (clause 7.3) shall then be transmitted 20 times. In each case, if a message is not successfully received the level of the unwanted signal shall be reduced by 1 dB and the new value noted.

If a message is successfully received, the level of the unwanted signal shall not be changed until three consecutive messages have been successfully received. In this case the unwanted signal shall be increased by 1 dB and the new value noted.

No level of the unwanted signal shall be noted unless preceded by a change in level.

The average of the values noted in steps d) and e) (which provides the level corresponding to the successful message ratio of 80 %) shall be noted.

- f) for each adjacent channel, the selectivity shall be expressed as the ratio, in dB, of the average level noted in step e) to the level of the wanted signal, at the receiver input;

This value shall be recorded.

- g) the measurement shall be repeated with the unwanted signal at the frequency of the channel below that of the wanted signal;

- h) the adjacent channel selectivity of the equipment under test shall be expressed as the lower of the two values measured in the upper and lower adjacent channel nearest to the receiving channel (see step f) above);

- i) the measurement shall be repeated under extreme test conditions (clauses 6.4.1 and 6.4.2 applied simultaneously), using the level of the wanted signal, as specified in clause 9.3 (data or messages), increased by 6 dB.

If analogue measurements according to EN 300 086 [1] have been made before, including adjacent channel selectivity under extreme test conditions, the adjacent channel selectivity (data or messages) shall be measured at normal test conditions only.

NOTE: This is a valid procedure because the degradation of adjacent channel selectivity at extreme test conditions is known by the analogue measurement results.

The limit(s) corresponding to this parameter can be found in clause 5.2.5.

9.7 Spurious response rejection

Spurious responses may occur at all frequencies throughout the frequency spectrum and the requirements of the present document shall be met for all frequencies. However, for practical reasons the measurements shall be performed as specified in the present document. More specifically, this method of measurement is not intended to capture all spurious responses but selects those that have a high probability of being present. However, in a limited frequency range close to the nominal frequency of the receiver, it has been considered impossible to determine the probability of a spurious response and therefore a search shall be performed over this limited frequency range. This method provides a high degree of confidence that the equipment also meets the requirements at frequencies not being measured.

9.7.1 Definition

The spurious response rejection is a measure of the capability of the receiver to receive a wanted modulated signal without exceeding a given degradation due to the presence of an unwanted modulated signal at any other frequency, at which a response is obtained.

9.7.2 Introduction to the method of measurement

To determine the frequencies at which spurious responses can occur the following calculations shall be made:

a) calculation of the "limited frequency range":

- the limited frequency range is defined as the frequency of the local oscillator signal (f_{LO}) applied to the first mixer of the receiver plus or minus the sum of the intermediate frequencies (f_{I1}, \dots, f_{In}) and a half the switching range (sr) of the receiver (clause 4);
- hence, the frequency f_l of the limited frequency range is:

$$f_{LO} - \sum_{j=1}^{j=n} f_{Ij} - \frac{sr}{2} \leq f_l \leq f_{LO} + \sum_{j=1}^{j=n} f_{Ij} + \frac{sr}{2}$$

b) calculation of frequencies outside the limited frequency range:

- a calculation of the frequencies at which spurious responses can occur outside the range determined in a) is made for the remainder of the frequency range of interest, as appropriate (clauses 9.7.4 and 9.7.5);
- the frequencies outside the limited frequency range are equal to the harmonics of the frequency of the local oscillator signal (f_{LO}) applied to the first mixer of the receiver plus or minus the first intermediate frequency (f_{I1}) of the receiver;
- hence, the frequencies of these spurious responses are:

$$nf_{LO} \pm f_{I1}$$

- where n is an integer greater than or equal to 2.

The measurement of the first image response of the receiver shall initially be made to verify the calculation of spurious response frequencies.

For the calculations a) and b) above, the manufacturer shall state the frequency of the receiver, the frequency of the local oscillator signal (f_{LO}) applied to the 1st mixer of the receiver, the intermediate frequencies (f_{I1} , f_{I2} etc.), and the switching range (sr) of the receiver.

9.7.3 Method of search over the "limited frequency range"

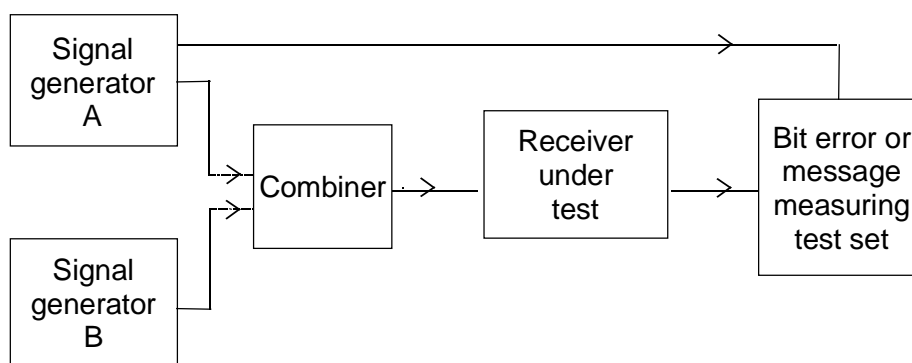

Figure 26: Measurement arrangement

The measurement procedure shall be as follows:

a) two signal generators, A and B, shall be connected to the receiver via a combining network (clause 7.1);

The wanted signal, provided by signal generator A, shall be at the nominal frequency of the receiver and shall have the normal test signal or modulation (clause 7.3).

The unwanted signal, provided by signal generator B, shall be modulated with signal A-M3 (clause 7.3).

- b) initially, signal generator B (unwanted signal) shall be switched off (maintaining the output impedance);

The level of the wanted signal from generator A shall be adjusted to the level which is 3 dB above the level of the limit of the maximum usable sensitivity as specified in clause 9.3 (data or messages), at the receiver input terminals (i.e. 6 dB above 1 μ V emf under normal test conditions).

In the case where a continuous bit stream is used, the bit error ratio of the receiver after demodulation shall be noted.

- c) signal generator B shall then be switched on, and the level of the unwanted signal adjusted to 86 dB μ V at the receiver input terminals;

The frequency of the unwanted signal generator shall be varied in increments of 5 kHz over the limited frequency range (clause 9.7.2 a)) and over the frequencies in accordance with the calculations outside of this frequency range (clause 9.7.2 b)).

- d) the frequency of any spurious response detected (e.g. by an increase in the previously noted bit error ratio) during the search shall be recorded for use in the measurements in accordance with clauses 9.7.4 and 9.7.5;
- e) in the case where operation using a continuous bit stream is not possible a similar method shall be used. In such case, instead of identifying a spurious response by noting an increase in the bit error ratio, spurious responses shall be identified by a degradation of the successful message ratio.

9.7.4 Method of measurement with continuous bit streams

The measurement shall be performed as follows, using the measurement arrangement of figure 26 in clause 9.7.3:

- a) two signals generators, A and B, shall be connected to the receiver via a combining network (clause 7.1);

The wanted signal, provided by signal generator A, shall be at the nominal frequency of the receiver and shall be modulated by the normal test signal D-M2 or D-M5, as appropriate (clause 7.3).

The unwanted signal, provided by signal generator B, shall be modulated with a frequency of 400 Hz and with a deviation of 12 % of the channel separation (A-M3) (clause 7.3), and shall be at the frequency of that spurious response being considered.

- b) initially, signal generator B (unwanted signal) shall be switched off (maintaining the output impedance);

The level of the wanted signal from generator A shall be adjusted to the level which is 3 dB above the level of the limit of the maximum usable sensitivity as specified in clause 9.3 (data or messages), at the receiver input terminals (i.e. 6 dB above 1 μ V emf under normal test conditions).

- c) signal generator B shall then be switched on, and the level of the unwanted signal adjusted until a bit error ratio of 10^{-1} or worse is obtained;
- d) the normal test signal D-M2 or D-M5 as appropriate shall be transmitted whilst observing the bit error ratio;
- e) the level of the unwanted signal shall be reduced in steps of 1 dB until a bit error ratio of 10^{-2} or better is obtained. The level of the unwanted signal shall then be noted;
- f) for each frequency, the spurious response rejection shall be expressed as the ratio, in dB, of the level of the unwanted signal to the level of the wanted signal, at the receiver input;

This ratio shall be recorded.

- g) the measurement shall be repeated at all spurious response frequencies found during the search over the "limited frequency range" (clause 9.7.2 a)) and at frequencies calculated for the remainder of the spurious response frequencies (clause 9.7.2 b)) in the frequency range from $f_{Rx}/3,2$ or 30 MHz, whichever is higher, to $3,2 \times f_{Rx}$, where f_{Rx} is the nominal frequency of the receiver;
- h) the spurious response rejection of the equipment under test shall be expressed as the lowest value recorded in step f).

The limit(s) corresponding to this parameter can be found in clause 5.2.6.

9.7.5 Method of measurement with messages

The measurement shall be performed as follows, using the measurement arrangement of figure 26 in clause 9.7.3:

- a) two signal generators, A and B, shall be connected to the receiver via a combining network (clause 7.1);

The wanted signal, provided by signal generator A, shall be at the nominal frequency of the receiver and shall have normal test modulation (clause 7.3).

The unwanted signal, provided by signal generator B, shall be modulated with a frequency of 400 Hz and with a deviation of 12 % of the channel separation (A-M3) (clause 7.3), and shall be at the frequency of that spurious response being considered.

- b) initially, signal generator B (unwanted signal) shall be switched off (maintaining the output impedance);

The level of the wanted signal from generator A shall be adjusted to the level which is 3 dB above the level of the limit of the maximum usable sensitivity as specified in clause 9.3 (data or messages), at the receiver input terminals (i.e. 6 dB above 1 μ V emf under normal test conditions).

- c) signal generator B shall then be switched on, and the level of the unwanted signal adjusted until a successful message ratio of less than 10 % is obtained;
- d) the normal test signal (clause 7.3) shall then be transmitted repeatedly whilst observing in each case whether or not a message is successfully received;

The level of the unwanted signal shall be reduced by 2 dB for each occasion that a message is not successfully received.

The procedure shall be continued until three consecutive messages are successfully received. The level of the input signal shall then be noted.

- e) the level of the unwanted signal shall be increased by 1 dB and the new value noted;

The normal test signal (clause 7.3) shall then be transmitted 20 times. In each case, if a message is not successfully received the level of the unwanted signal shall be reduced by 1 dB and the new value noted.

If a message is successfully received, the level of the unwanted signal shall not be changed until three consecutive messages have been successfully received. In this case the unwanted signal shall be increased by 1 dB and the new value noted.

No level of the unwanted signal shall be noted unless preceded by a change in level.

The average of the values noted in steps d) and e) (which provides the level corresponding to the successful message ratio of 80 % shall be noted.

- f) for each frequency, the spurious response rejection shall be expressed as the ratio, in dB, of the level of the unwanted signal to the level of the wanted signal, at the receiver input;

This ratio shall be recorded.

- g) the measurement shall be repeated at all spurious response frequencies found during the search over the limited frequency range, (clause 9.7.2 a)) and at frequencies calculated for the remainder of the spurious response frequencies (clause 9.7.2, b)) in the frequency range from $f_{R_x}/3,2$ or 30 MHz, whichever is higher, to $3,2 \times f_{R_x}$, where f_{R_x} is the nominal frequency of the receiver;

- h) the spurious response rejection of the equipment under test shall be expressed as the lowest value recorded in step f).

The limit(s) corresponding to this parameter can be found in clause 5.2.6.

9.8 Intermodulation response rejection

9.8.1 Definition

The intermodulation response rejection is a measure of the capability of the receiver to receive a wanted modulated signal, without exceeding a given degradation due to the presence of two or more unwanted signals with a specific frequency relationship to the wanted signal frequency.

9.8.2 Method of measurement with continuous bit streams

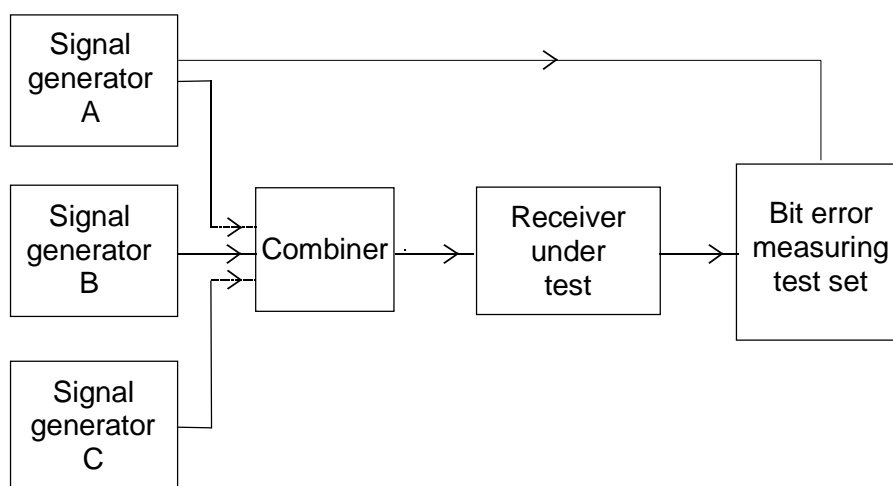

Figure 27: Measurement arrangement

The measurement procedure shall be as follows:

- a) three signal generators, A, B and C, shall be connected to the receiver via a combining network (clause 7.1);
 - The wanted signal, provided by signal generator A, shall be at the nominal frequency of the receiver and shall be modulated by the normal test signal D-M2 or D-M5, as appropriate (clause 7.3).
 - The first unwanted signal, provided by signal generator B, shall be unmodulated and adjusted to a frequency 50 kHz above the nominal frequency of the receiver.
 - The second unwanted signal, provided by signal generator C, shall be modulated with signal A-M3 (clause 7.3) and adjusted to a frequency 100 kHz above the nominal frequency of the receiver.
- b) initially, signal generators B and C (unwanted signals) shall be switched off (maintaining the output impedance);

The level of the wanted signal from generator A shall be adjusted to the level which is 3 dB above the level of the limit of the maximum usable sensitivity as specified in clause 9.3 (data or messages), at the receiver input terminals (i.e. 6 dB above 1 μ V emf under normal test conditions).
- c) signal generators B and C shall then be switched on; the levels of the two unwanted signals shall be maintained equal and shall be adjusted until a bit error ratio of 10^{-1} or worse is obtained;
- d) the normal test signal D-M2 or D-M5, as appropriate shall then be transmitted whilst observing the bit error ratio;
- e) the level of the unwanted signals shall be reduced in steps of 1 dB until a bit error ratio of 10^{-2} or better is obtained. The level of the unwanted signals shall then be noted;
- f) for each configuration of the unwanted signals, the intermodulation response rejection shall be expressed as the ratio, in dB, of the level of the unwanted signals to the level of the wanted signal, at the receiver input;

This ratio shall be recorded.

- g) the measurement shall be repeated with the unwanted signal generator B at the frequency 50 kHz below that of the wanted signal and the frequency of the unwanted signal generator C at the frequency 100 kHz below that of the wanted signal;
- h) the intermodulation response rejection of the equipment under test shall be expressed as the lower of the two values recorded in step f).

The limit(s) corresponding to this parameter can be found in clause 5.2.7.

9.8.3 Method of measurement with messages

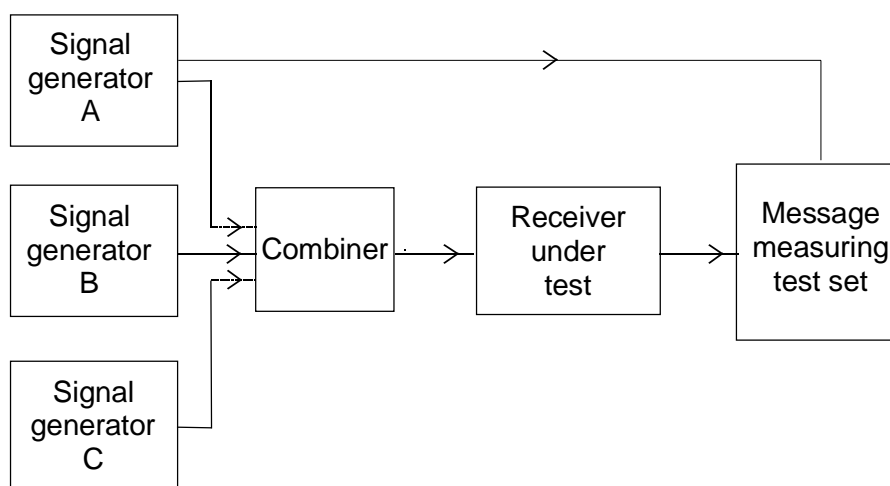

Figure 28: Measurement arrangement

The measurement procedure shall be as follows:

- a) three signal generators, A, B and C, shall be connected to the receiver via a combining network (clause 7.1);
- The wanted signal, provided by signal generator A, shall be at the nominal frequency of the receiver and shall have normal test modulation (clause 7.3).
- The first unwanted signal, provided by signal generator B, shall be unmodulated and adjusted to a frequency 50 kHz above the nominal frequency of the receiver.
- The second unwanted signal, provided by signal generator C, shall be modulated with signal A-M3 (clause 7.3) and adjusted to a frequency 100 kHz above the nominal frequency of the receiver.
- b) initially, signal generators B and C (unwanted signals) shall be switched off (maintaining the output impedance);
- The level of the wanted signal from generator A shall be adjusted to the level which is 3 dB above the level of the limit of the maximum usable sensitivity as specified in clause 9.3 (data or messages), at the receiver input terminals (i.e. 6 dB above 1 μ V emf under normal test conditions).
- c) signal generators B and C shall then be switched on; the levels of the two unwanted signals shall be maintained equal and shall be adjusted until a successful message ratio of less than 10 % is obtained;
- d) the normal test signal (clause 7.3) shall then be transmitted repeatedly whilst observing in each case whether or not a message is successfully received;
- The levels of the unwanted signals shall be reduced by 2 dB for each occasion that a message is not successfully received.
- The procedure shall be continued until three consecutive messages are successfully received. The level of the input signals shall then be noted.

- e) the level of the unwanted signals shall be increased by 1 dB and the new value noted;

The normal test signal (clause 7.3) shall then be transmitted 20 times. In each case, if a message is not successfully received the level of the unwanted signals shall be reduced by 1 dB and the new value noted.

If a message is successfully received, the level of the unwanted signals shall not be changed until three consecutive messages have been successfully received. In this case the unwanted signals shall be increased by 1 dB and the new value noted.

No level of the unwanted signals shall be noted unless preceded by a change in level.

The average of the values noted in steps d) and e) (which provides the level corresponding to the successful message ratio of 80 %) shall be noted.

- f) for each configuration of the unwanted signals, the intermodulation response rejection shall be expressed as the ratio, in dB, of the average level noted in step e) to the level of the wanted signal, at the receiver input;

This ratio shall be recorded.

- g) the measurement shall be repeated with the unwanted signal generator B at the frequency 50 kHz below that of the wanted signal and the frequency of the unwanted signal generator C at the frequency 100 kHz below that of the wanted signal;

- h) the intermodulation response rejection of the equipment under test shall be expressed as the lower of the two values recorded in step f).

The limit(s) corresponding to this parameter can be found in clause 5.2.7.

9.9 Blocking or desensitization

9.9.1 Definition

Blocking is a measure of the capability of the receiver to receive a wanted modulated signal without exceeding a given degradation due to the presence of an unwanted input signal at any frequencies other than those of the spurious responses or the adjacent channels.

9.9.2 Method of measurement with continuous bit streams

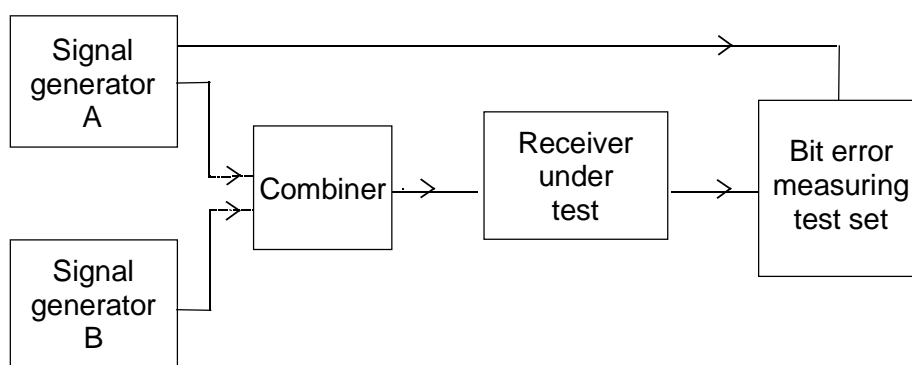

Figure 29: Measurement arrangement

The measurement procedure shall be as follows:

- a) two signal generators, A and B, shall be connected to the receiver via a combining network (clause 7.1);

The wanted signal, provided by signal generator A, shall be at the nominal frequency of the receiver and shall be modulated by the normal test signal D-M2 or D-M5, as appropriate (clause 7.3).

The unwanted signal, provided by signal generator B, shall be unmodulated and shall be at a frequency from 1 MHz to 10 MHz away from the nominal frequency of the receiver.

For practical reasons the measurements shall be carried out at frequencies of the unwanted signal at approximately ± 1 MHz, ± 2 MHz, ± 5 MHz and ± 10 MHz, avoiding those frequencies at which spurious responses could occur (clause 9.7).

- b) initially, signal generator B (unwanted signal) shall be switched off (maintaining the output impedance);

The level of the wanted signal from generator A shall be adjusted to the level which is 3 dB above the level of the limit of the maximum usable sensitivity as specified in clause 9.3 (data or messages), at the receiver input terminals (i.e. 6 dB above 1 μ V emf under normal test conditions).

- c) signal generator B shall then be switched on, and the level of the unwanted signal adjusted until a bit error ratio of 10^{-1} or worse is obtained;
- d) the normal test signal D-M2 or D-M5, as appropriate shall be transmitted whilst observing the bit error ratio;
- e) the level of the unwanted signal shall be reduced in steps of 1 dB until a bit error ratio of 10^{-2} or better is obtained. The level of the unwanted signal shall then be noted;
- f) for each frequency, the blocking or desensitization shall be expressed as the ratio, in dB, of the level of the unwanted signal to the level of the wanted signal, at the receiver input;

This ratio shall be recorded.

- g) the measurement shall be repeated for all the frequencies defined in step a);
- h) the blocking or desensitization of the equipment under test shall be expressed as the lowest of the values recorded in step f).

The limit(s) corresponding to this parameter can be found in clause 5.2.8.

9.9.3 Method of measurement with messages

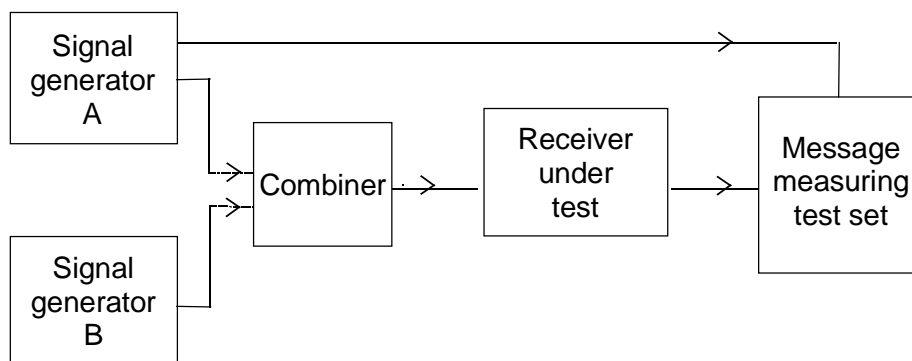

Figure 30: Measurement arrangement

The measurement procedure shall be as follows:

- a) two signal generators, A and B, shall be connected to the receiver via a combining network (clause 7.1);

The wanted signal, provided by signal generator A, shall be at the nominal frequency of the receiver and shall have normal test modulation (clause 7.3).

The unwanted signal, provided by signal generator B, shall be unmodulated and shall be at a frequency from 1 MHz to 10 MHz away from the nominal frequency of the receiver.

For practical reasons the measurements shall be carried out at frequencies of the unwanted signal at approximately ± 1 MHz, ± 2 MHz, ± 5 MHz and ± 10 MHz, avoiding those frequencies at which spurious responses could occur (clause 9.7).

- b) initially, signal generator B (unwanted signal) shall be switched off (maintaining the output impedance);

The level of the wanted signal from generator A shall be adjusted to the level which is 3 dB above the level of the limit of the maximum usable sensitivity as specified in clause 9.3 (data or messages) at the receiver input terminals (i.e. 6 dB above 1 μ V emf under normal test conditions).

- c) signal generator B shall then be switched on, and the level of the unwanted signal adjusted until a successful message ratio of less than 10 % is obtained;
- d) the normal test signal (clause 7.3) shall then be transmitted repeatedly whilst observing in each case whether or not a message is successfully received;

The level of the unwanted signal shall be reduced by 2 dB for each occasion that a message is not successfully received.

The procedure shall be continued until three consecutive messages are successfully received. The level of the input signal shall then be noted.

- e) the level of the unwanted signal shall be increased by 1 dB and the new value noted;

The normal test signal (clause 7.3) shall then be transmitted 20 times. In each case, if a message is not successfully received the level of the unwanted signal shall be reduced by 1 dB and the new value noted.

If a message is successfully received, the level of the unwanted signals shall not be changed until three consecutive messages have been successfully received. In this case the unwanted signal shall be increased by 1 dB and the new value noted.

No level of the unwanted signal shall be noted unless preceded by a change in level.

The average of the values noted in steps d) and e) (which provides the level corresponding to the successful message ratio of 80 %) shall be noted.

- f) for each frequency, the blocking or desensitization shall be expressed as the ratio, in dB, of the level of the unwanted signal to the level of the wanted signal, at the receiver input;

This ratio shall be recorded.

- g) the measurement shall be repeated for all the frequencies defined in step a);

- h) the blocking or desensitization of the equipment under test shall be expressed as the lowest of the values recorded in step f).

The limit(s) corresponding to this parameter can be found in clause 5.2.8.

9.10 Spurious radiations

9.10.1 Definition

Spurious radiations from the receiver are emissions at any frequency, radiated by the equipment and its antenna.

The level of spurious radiations shall be measured by:

either:

- a) their power level in a specified load (conducted spurious emission); and
- b) their effective radiated power when radiated by the cabinet and structure of the equipment (cabinet radiation);
or
- c) their effective radiated power when radiated by the cabinet and by the integral antenna, in the case of hand portable equipment fitted with such an antenna and no external RF connector.

9.10.2 Method of measuring the power level

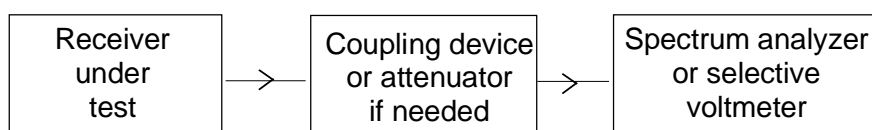

Figure 31: Measurement arrangement

This method applies only to equipment having an external antenna connector.

Spurious radiations shall be measured as the power level of any discrete signal at the input terminals of the receiver. The receiver input terminals are connected to a spectrum analyser or selective Voltmeter having an input impedance of 50 Ω and the receiver is switched on.

If the detecting device is not calibrated in terms of power input, the level of any detected components shall be determined by a substitution method using a signal generator.

The measurements shall extend, for equipment operating on frequencies not exceeding 470 MHz, over the frequency range of 9 kHz to 4 GHz, and in addition shall be repeated over the frequency range 4 GHz to 12,75 GHz for equipment operating on frequencies above 470 MHz.

The limit(s) corresponding to this parameter can be found in clause 5.2.9.

9.10.3 Method of measuring the effective radiated power

Test site

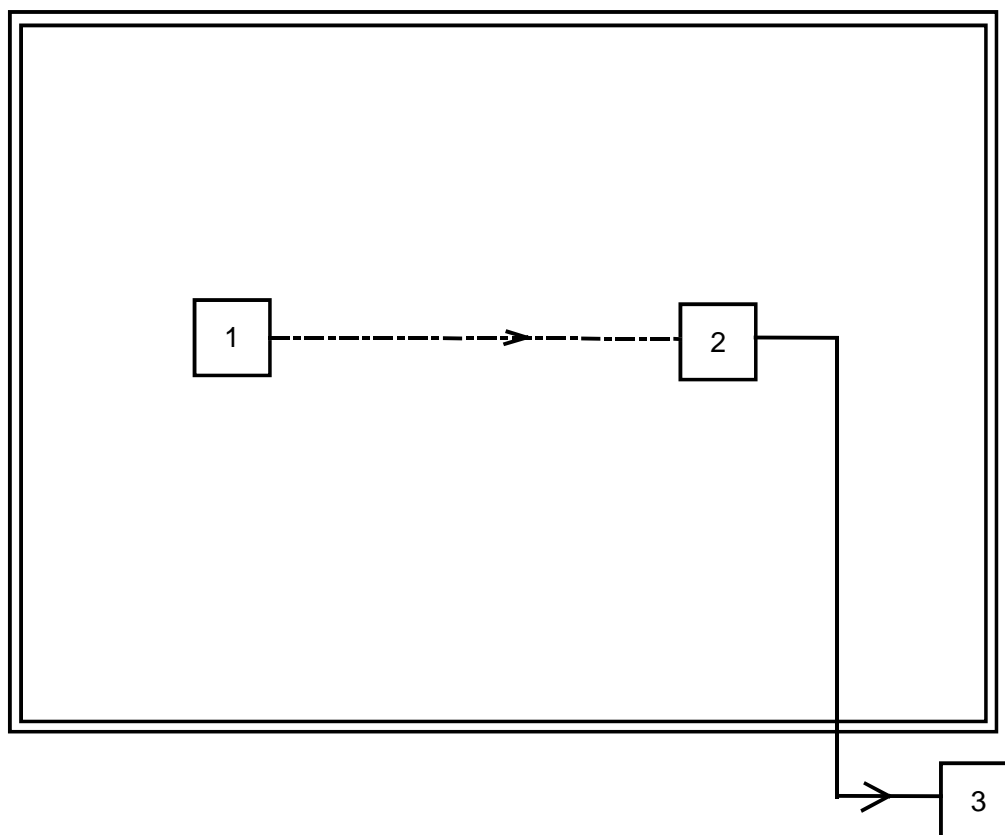

- 1) receiver under test
- 2) test antenna
- 3) spectrum analyser or selective Voltmeter (test receiver)

Figure 32: Measurement arrangement

The measurement procedure shall be as follows:

- a) on a test site, fulfilling the requirements of annex A, the sample shall be placed at the specified height on the non-conducting support;

The receiver shall be operated from a power source via a radio frequency filter to avoid radiation from the power leads.

- b) the receiver shall be connected:

- to an artificial antenna (clause 7.7) for equipment having an external antenna connector (clause 9.10.1 b)); or
- to the integral antenna (clause 9.10.1 c));

- c) radiation of any spurious components shall be detected by the test antenna and receiver, over the frequency range 30 MHz to 4 GHz;

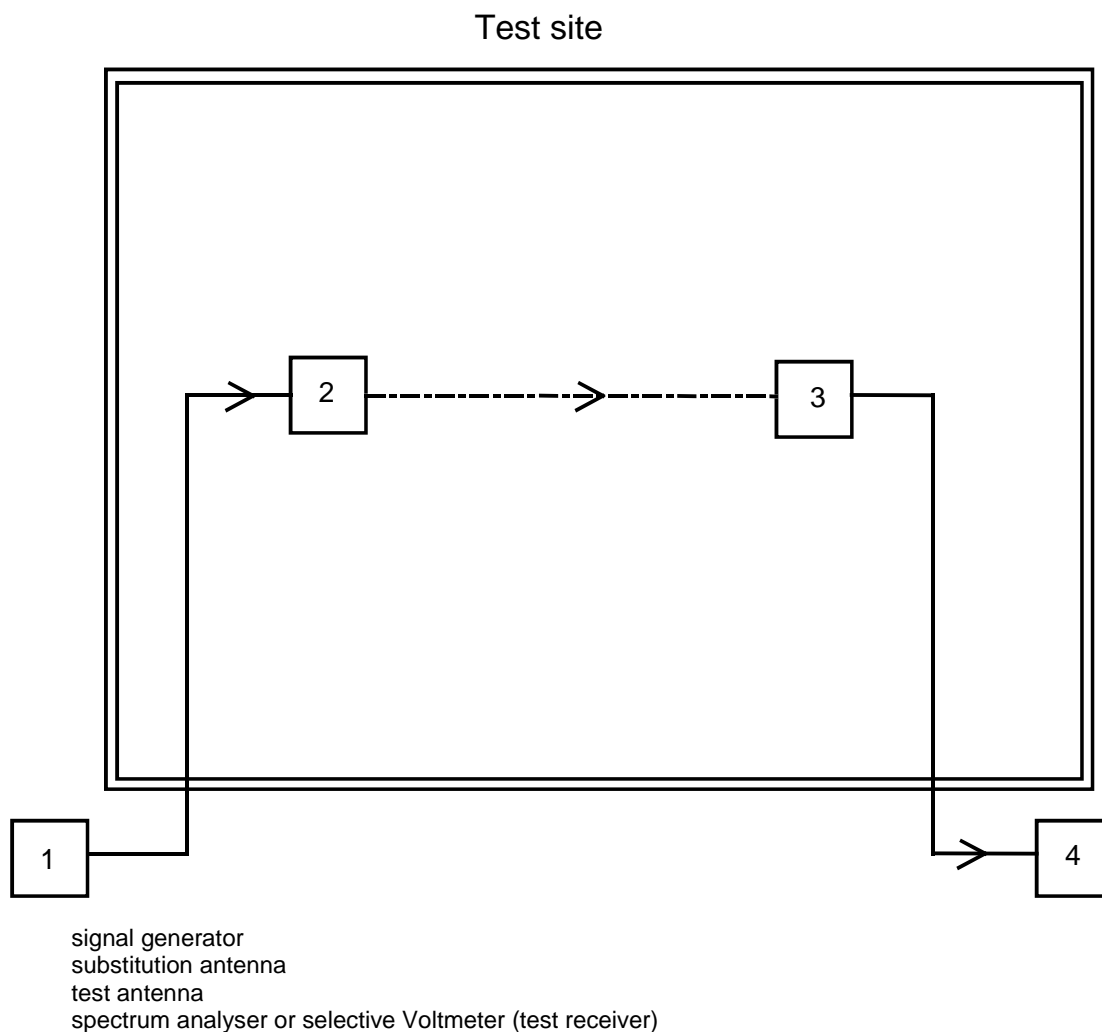

Figure 33: Measurement arrangement

- d) at each frequency at which a component is detected, the sample shall be rotated to obtain maximum response and the effective radiated power of that component determined by a substitution measurement, using the measurement arrangement of figure 33;

The value of the effective radiated power of that component shall be recorded.

- e) the measurement shall be repeated with the test antenna in the orthogonal polarization plane.

The limit(s) corresponding to this parameter can be found in clause 5.2.9.

10 Duplex operation

If the equipment is designed for duplex operation, the following additional measurements shall be carried out to ensure satisfactory duplex operation.

Equipment made available for such measurements shall be fitted with a duplex filter.

Duplex measurements shall be carried out on a single pair of frequencies only, as specified by the manufacturer (in consultation with the appropriate testing laboratory (if appropriate)).

10.1 Receiver desensitization (with simultaneous transmission and reception)

10.1.1 Definition

The desensitization is the degradation of the sensitivity of the receiver resulting from the transfer of power from the transmitter to the receiver due to coupling effects. It is expressed as the difference in dB between the maximum usable sensitivity levels (data or messages, conducted), with and without simultaneous transmissions.

10.1.2 Desensitization measured with continuous bit streams

10.1.2.1 Method of measurement when the equipment has a duplex filter

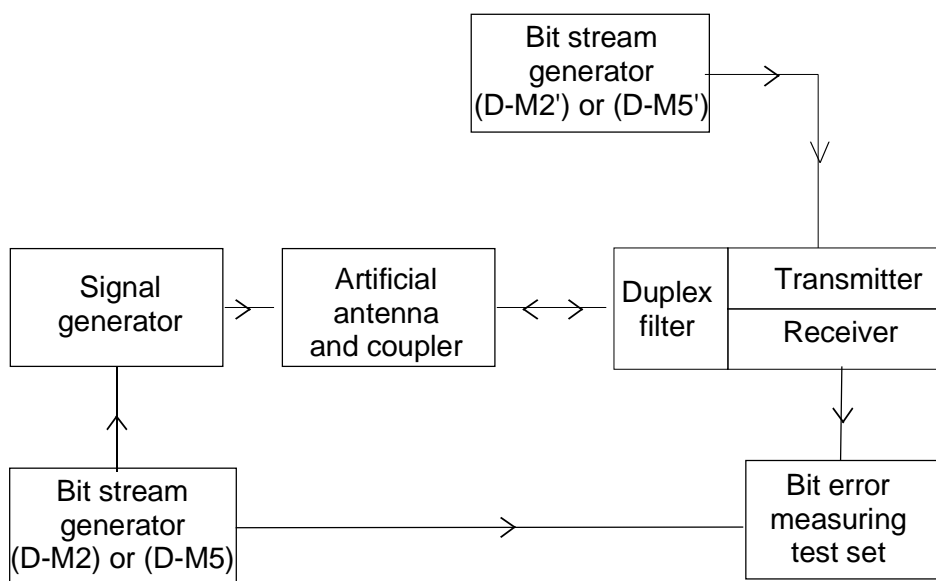

Figure 34: Measurement arrangement

The measurement procedure shall be as follows:

- a) the antenna terminal of the equipment comprising of the receiver, transmitter and duplex filter, shall be connected through a coupling device to the artificial antenna specified in clause 7.7;

A signal generator modulated by the normal test signal D-M2 or D-M5, as appropriate (clause 7.3), shall be connected to the coupling device so that it does not affect the impedance matching and does not generate intermodulation products which could impair the results of the measurement.

- b) the transmitter shall be brought into operation at the carrier output power as defined in clause 8.2, modulated by the normal test signal D-M2' or D-M5', as appropriate (clause 7.3);

The receiver sensitivity (data, conducted) shall then be measured in accordance with clause 9.1.2.

- c) the output level of the signal generator shall be noted as C in dB relative to an emf of 1 μ V;
- d) the transmitter shall then be switched off and the receiver sensitivity (data, conducted) is measured again;
- e) the output level of the signal generator shall be noted as D in dB relative to an emf of 1 μ V;
- f) the desensitization is the difference between the values of C and D in dB.

The limit(s) corresponding to this parameter can be found in clause 5.3.1.

10.1.2.2 Method of measurement when the equipment has to operate with two antennas

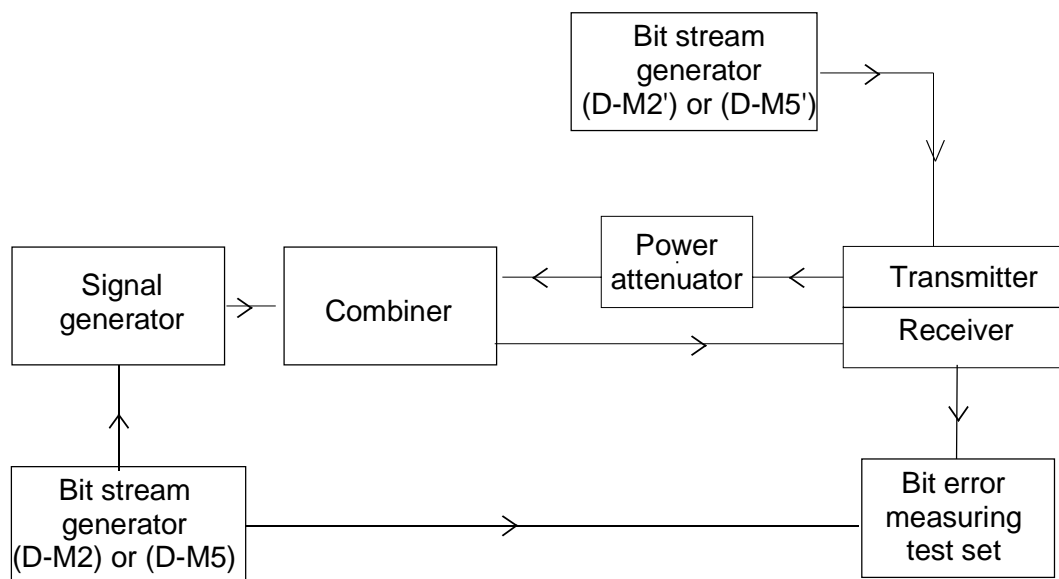

Figure 35: Measurement arrangement

The measurement procedure shall be as follows:

- a) the transmitter shall be connected to a power attenuator (in order to dissipate the nominal RF output power of the transmitter) the rating of which shall be declared by the manufacturer;

The attenuator output shall be connected to the receiver input by means of a coupling device and a filter, if the latter is part of the standard equipment. The total attenuation between transmitter and receiver shall be 30 dB.

A signal generator modulated by the normal test signal D-M2 or D-M5, as appropriate (clause 7.3) shall be connected to the coupling device in such a way as not to affect the impedance matching and does not generate intermodulation products which could impair the results of the measurement.

- b) the transmitter shall be brought into operation with an output power as defined in clause 8.2, modulated by the normal test signal D-M2' or D-M5', as appropriate (clause 7.3);

The receiver sensitivity (data, conducted) shall then be measured in accordance with clause 9.1.2.

- c) the output level of the signal generator shall be noted as C in dB relative to an emf of 1 μ V;
- d) the transmitter shall then be switched off and the receiver sensitivity (data, conducted) measured again;
- e) the output level of the signal generator shall be noted as D in dB relative to an emf of 1 μ V;
- f) the desensitization is the difference between the values of C and D in dB.

The limit(s) corresponding to this parameter can be found in clause 5.3.1.

10.1.3 Desensitization measured with messages

10.1.3.1 Method of measurement when the equipment has a duplex filter

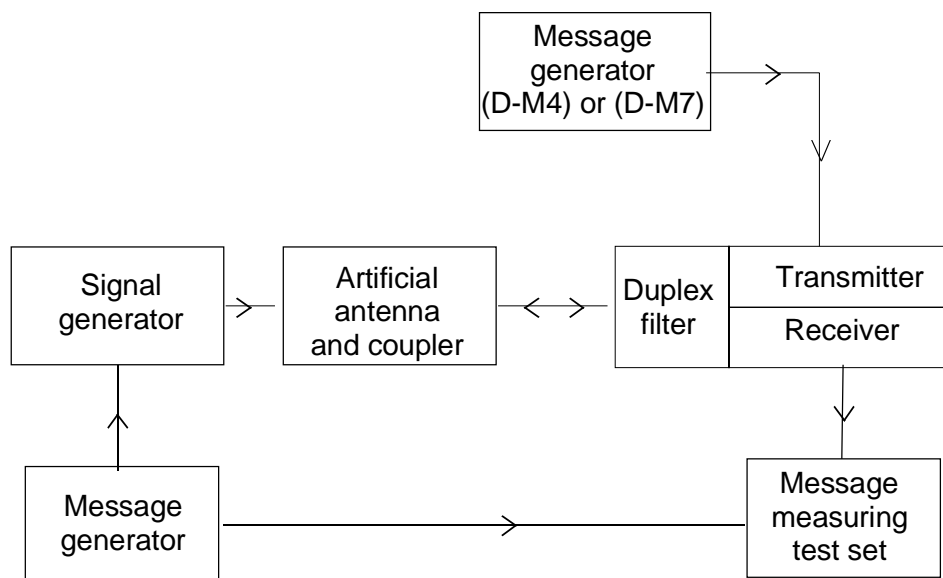

Figure 36: Measurement arrangement

The measurement procedure shall be as follows:

- a) the antenna terminal of the equipment comprising of the receiver, transmitter and duplex filter, shall be connected through a coupling device to the artificial antenna specified in clause 7.7;

A signal generator having normal test modulation (clause 7.3) shall be connected to the coupling device so that it does not affect the impedance matching and does not generate intermodulation products which could impair the results of the measurement.

- b) the transmitter shall be brought into operation with an output power as defined in clause 8.2, and shall be modulated by the normal test signal D-M4 or D-M7, as appropriate (clause 7.3), using a message different from the message used in step a);

The receiver sensitivity (messages, conducted) shall then be measured in accordance with clause 9.1.3.

- c) the output level of the signal generator shall be noted as C in dB relative to an emf of 1 μ V;
- d) the transmitter shall then be switched off and the receiver sensitivity (messages, conducted) measured again;
- e) the output level of the signal generator shall be noted as D in dB relative to an emf of 1 μ V;
- f) the desensitization is the difference between the values of C and D in dB.

The limit(s) corresponding to this parameter can be found in clause 5.3.1.

10.1.3.2 Method of measurement when the equipment has to operate with two antennas

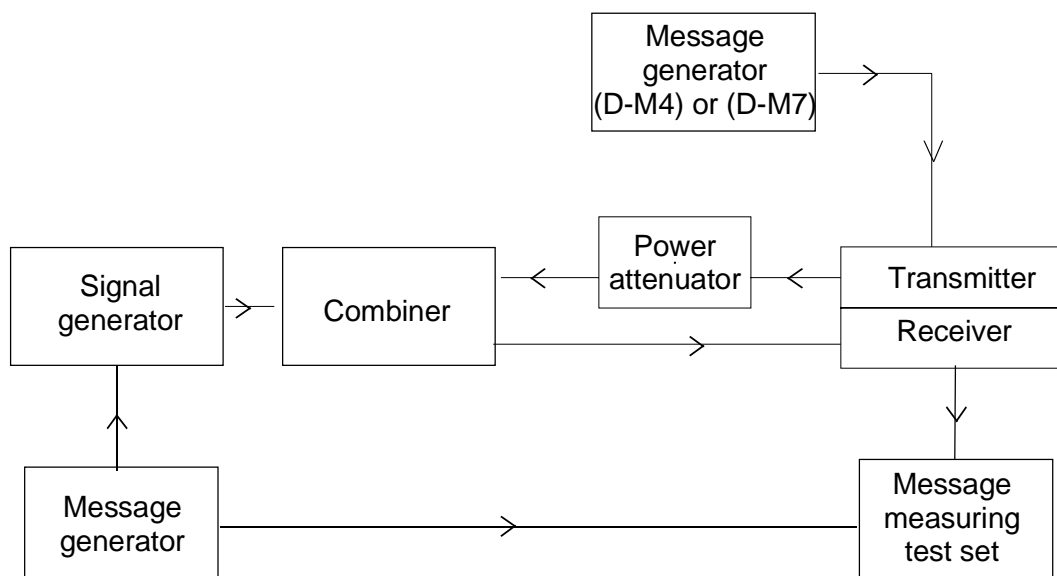

Figure 37: Measurement arrangement

The measurement procedure shall be as follows:

- a) the transmitter shall be connected to a power attenuator (in order to dissipate the nominal RF output power of the transmitter) the rating of which shall be declared by the manufacturer;

The attenuator output shall be connected to the receiver input by means of a coupling device and a filter, if the latter is part of the standard equipment. The total attenuation between transmitter and receiver shall be 30 dB.

A signal generator having normal test modulation (clause 7.3) shall be connected to the coupling device so that it does not affect the impedance matching and does not generate intermodulation products which could impair the results of the measurement.

- b) the transmitter shall be brought into operation with an output power as defined in clause 8.2, and shall be modulated by the normal test signal D-M4 or D-M7, as appropriate (clause 7.3) using a message different from the message used in step a);

The receiver sensitivity (messages, conducted) shall then be measured in accordance with clause 9.1.3.

- c) the output level of the signal generator shall be noted as C in dB relative to an emf of 1 μ V;
- d) the transmitter shall then be switched off and the receiver sensitivity (messages, conducted) measured again;
- e) the output level of the signal generator shall be noted as D in dB relative to an emf of 1 μ V;
- f) the desensitization is the difference between the values of C and D in dB.

The limit(s) corresponding to this parameter can be found in clause 5.3.1.

10.2 Receiver spurious response rejection (with simultaneous transmission and reception)

10.2.1 Definition

The spurious response rejection, under duplex operation, is a measure of the capability of the receiver to achieve a specific spurious response rejection ratio when receiving a wanted modulated signal in the presence of:

- a) an unwanted signal at any other frequency, at which a response may be obtained; and
- b) the unmodulated signal of the transmitter operating at duplex frequency distance, at the rated output power and attenuated by the duplex filter or by the distance between the antennas.

10.2.2 Method of measurement

The receiver spurious response rejection under duplex operation shall be measured as specified in clause 9.7 with the measurement arrangement described in clauses 10.1.2 or 10.1.3, except that the transmitter shall be unmodulated. The transmitter shall be operated at the carrier output power as defined in clause 8.2.

The measurement shall be performed around frequencies f_m derived from the expressions:

$$(p)f_t + (q)f_m = f_r \text{ and } f_m = (n)f_t \pm f_{I1};$$

where:

- f_t is the transmitter frequency;
- f_r is the receiver frequency; and
- f_{I1} is the first IF of the receiver;
- $n = \geq 2$.

Particular attention should be made to the following values:

$$(p) = -1, (q) = 2 \text{ and } (p) = 2, (q) = -1.$$

It should be noted that the method of measurement described may cause errors at certain frequencies due to the effect of signal generator intermodulation. To overcome such errors, a band stop filter at the transmitting frequency may be used, in conjunction with the signal generator combining network.

The limit(s) corresponding to this parameter can be found in clause 5.3.2.

11 Measurement uncertainty

Table 9: Absolute measurement uncertainties: maximum values

Parameter	Uncertainty
Radio Frequency	$\pm 1 \times 10^{-7}$
RF Power, conducted (up to 160 W)	$\pm 0,75$ dB
Radiated RF power	± 6 dB
Adjacent channel power	± 5 dB
Sensitivity	± 3 dB
Two-signal measurement, valid up to 4 GHz	± 4 dB
Three-signal measurement	± 3 dB
Conducted spurious emission of transmitter, valid up to 12,75 GHz	± 4 dB
Conducted spurious emission of receiver, valid up to 12,75 GHz	± 3 dB
Radiated emission of the transmitter, valid up to 4 GHz	± 6 dB
Radiated emission of receiver, valid up to 4 GHz	± 6 dB
Transmitter transient frequency (frequency difference)	± 250 Hz
Transmitter transient time	± 20 %
NOTE: Values valid up to 1 GHz for the RF parameters unless otherwise stated.	

For the test methods, according to the present document, the measurement uncertainty figures shall be calculated in accordance with TR 100 028 [4] and shall correspond to an expansion factor (coverage factor) $k = 1,96$ or $k = 2$ (which provide confidence levels of respectively 95 % and 95,45 % in the case where the distributions characterizing the actual measurement uncertainties are normal (Gaussian)).

Table 9 is based on such expansion factors.

The particular expansion factor used for the evaluation of the measurement uncertainty shall be stated.

ETR 273 [5] provides further information concerning the usage of test sites.

Annex A (normative): Radiated measurement

A.1 Test sites and general arrangements for measurements involving the use of radiated fields

This annex introduces three most commonly available test sites, an Anechoic Chamber, an Anechoic Chamber with a ground plane and an Open Area Test Site (OATS), which may be used for radiated tests. These test sites are generally referred to as free field test sites. Both absolute and relative measurements can be performed in these sites. Where absolute measurements are to be carried out, the chamber should be verified. A detailed verification procedure is described in ETR 273 [5] relevant parts 2, 3 and 4.

NOTE: To ensure reproducibility and traceability of radiated measurements only these test sites should be used in measurements in accordance with the present document.

A.1.1 Anechoic Chamber

An Anechoic Chamber is an enclosure, usually shielded, whose internal walls, floor and ceiling are covered with radio absorbing material, normally of the pyramidal urethane foam type. The chamber usually contains an antenna support at one end and a turntable at the other. A typical Anechoic Chamber is shown in figure A.1.

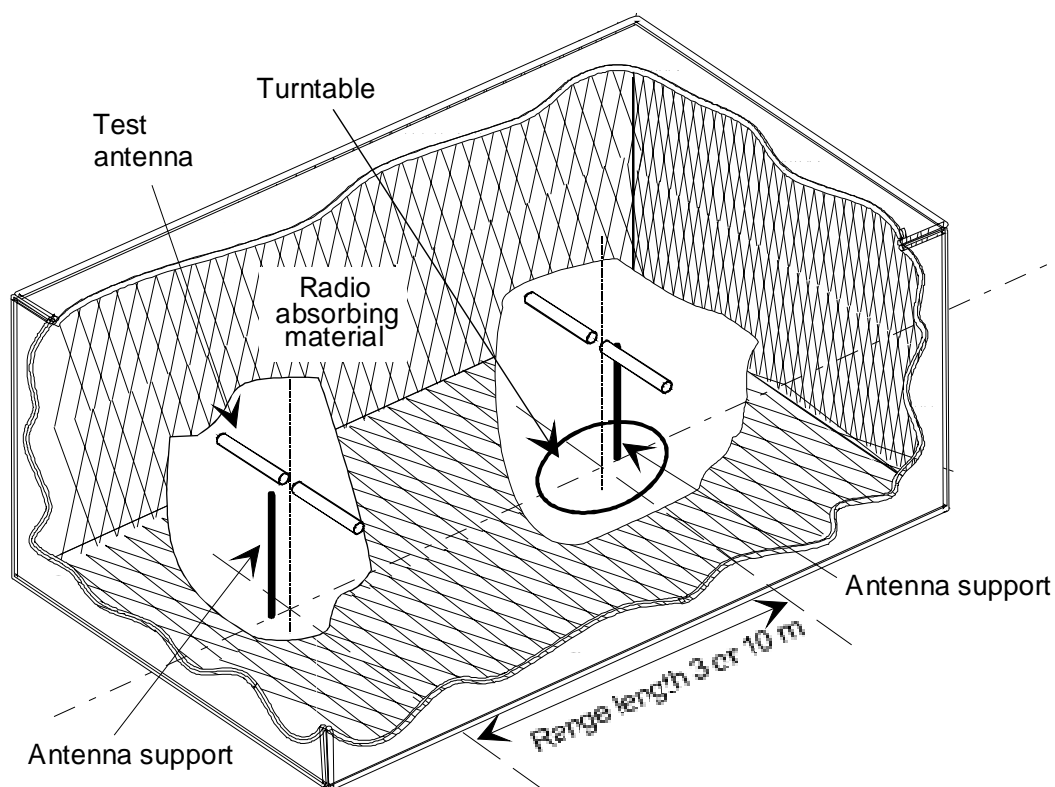

Figure A.1: A typical Anechoic Chamber

The chamber shielding and radio absorbing material work together to provide a controlled environment for testing purposes. This type of test chamber attempts to simulate free space conditions.

The shielding provides a test space, with reduced levels of interference from ambient signals and other outside effects, whilst the radio absorbing material minimizes unwanted reflections from the walls and ceiling which can influence the measurements. In practice it is relatively easy for shielding to provide high levels (80 dB to 140 dB) of ambient interference rejection, normally making ambient interference negligible.

A turntable is capable of rotation through 360° in the horizontal plane and it is used to support the test sample (EUT) at a suitable height (e.g. 1 m.) above the ground plane. The chamber shall be large enough to allow the measuring distance of at least 3 m or $2(d_1 + d_2)^2/\lambda$ (m), whichever is greater (see to clause A.2.5). The distance used in actual measurements shall be recorded with the test results.

The Anechoic Chamber generally has several advantages over other test facilities. There is minimal ambient interference, minimal floor, ceiling and wall reflections and it is independent of the weather. It does however have some disadvantages which include limited measuring distance and limited lower frequency usage due to the size of the pyramidal absorbers. To improve low frequency performance, a combination structure of ferrite tiles and urethane foam absorbers is commonly used.

All types of emission, sensitivity and immunity testing can be carried out within an Anechoic Chamber without limitation.

A.1.2 Anechoic Chamber with a conductive ground plane

An Anechoic Chamber with a conductive ground plane is an enclosure, usually shielded, whose internal walls and ceiling are covered with radio absorbing material, normally of the pyramidal urethane foam type. The floor, which is metallic, is not covered and forms the ground plane. The chamber usually contains an antenna mast at one end and a turntable at the other. A typical Anechoic Chamber with a conductive ground plane is shown in figure A.2.

This type of test chamber attempts to simulate an ideal Open Area Test Site whose primary characteristic is a perfectly conducting ground plane of infinite extent.

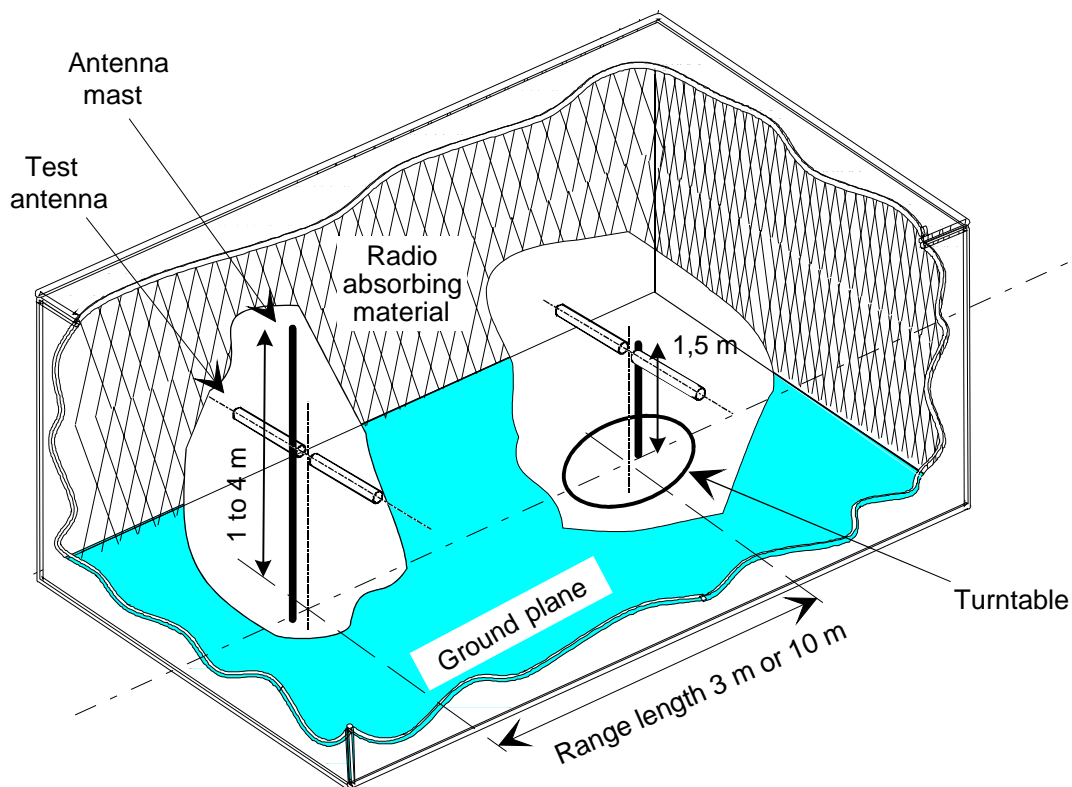

Figure A.2: A typical Anechoic Chamber with a conductive ground plane

In this facility the ground plane creates the wanted reflection path, such that the signal received by the receiving antenna is the sum of the signals from both the direct and reflected transmission paths. This creates a unique received signal level for each height of the transmitting antenna (or EUT) and the receiving antenna above the ground plane.

The antenna mast provides a variable height facility (from 1 m to 4 m) so that the position of the test antenna can be optimized for maximum coupled signal between antennas or between a EUT and the test antenna.

A turntable is capable of rotation through 360° in the horizontal plane and it is used to support the test sample (EUT) at a specified height, usually 1,5 m. above the ground plane. The chamber shall be large enough to allow the measuring distance of at least 3 m or $2(d_1 + d_2)^2/\lambda$ (m), whichever is greater (see clause A.2.5). The distance used in actual measurements shall be recorded with the test results.

Emission testing involves firstly "peaking" the field strength from the EUT by raising and lowering the receiving antenna on the mast (to obtain the maximum constructive interference of the direct and reflected signals from the EUT) and then rotating the turntable for a "peak" in the azimuth plane. At this height of the test antenna on the mast, the amplitude of the received signal is noted. Secondly the EUT is replaced by a substitution antenna (positioned at the EUT's phase or volume centre) which is connected to a signal generator. The signal is again "peaked" and the signal generator output adjusted until the level, noted in stage one, is again measured on the receiving device.

Receiver sensitivity tests over a ground plane also involve "peaking" the field strength by raising and lowering the test antenna on the mast to obtain the maximum constructive interference of the direct and reflected signals, this time using a measuring antenna which has been positioned where the phase or volume centre of the EUT will be during testing. A transform factor is derived. The test antenna remains at the same height for stage two, during which the measuring antenna is replaced by the EUT. The amplitude of the transmitted signal is reduced to determine the field strength level at which a specified response is obtained from the EUT.

A.1.3 Open Area Test Site (OATS)

An Open Area Test Site comprises a turntable at one end and an antenna mast of variable height at the other end above a ground plane which, in the ideal case, is perfectly conducting and of infinite extent. In practice, whilst good conductivity can be achieved, the ground plane size has to be limited. A typical Open Area Test Site is shown in figure A.3.

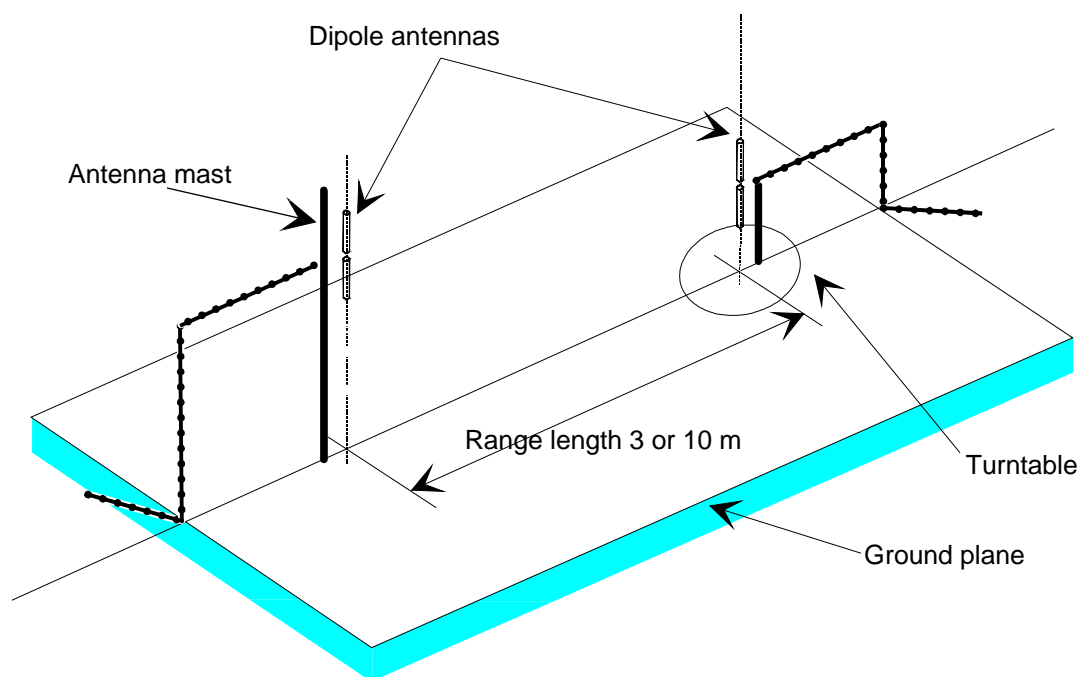

Figure A.3: A typical Open Area Test Site

The ground plane creates a wanted reflection path, such that the signal received by the receiving antenna is the sum of the signals received from the direct and reflected transmission paths. The phasing of these two signals creates a unique received level for each height of the transmitting antenna (or EUT) and the receiving antenna above the ground plane.

Site qualification concerning antenna positions, turntable, measurement distance and other arrangements are same as for Anechoic Chamber with a ground plane. In radiated measurements an OATS is also used by the same way as anechoic chamber with a ground plane.

Typical measuring arrangement common for ground plane test sites is presented in figure A.4.

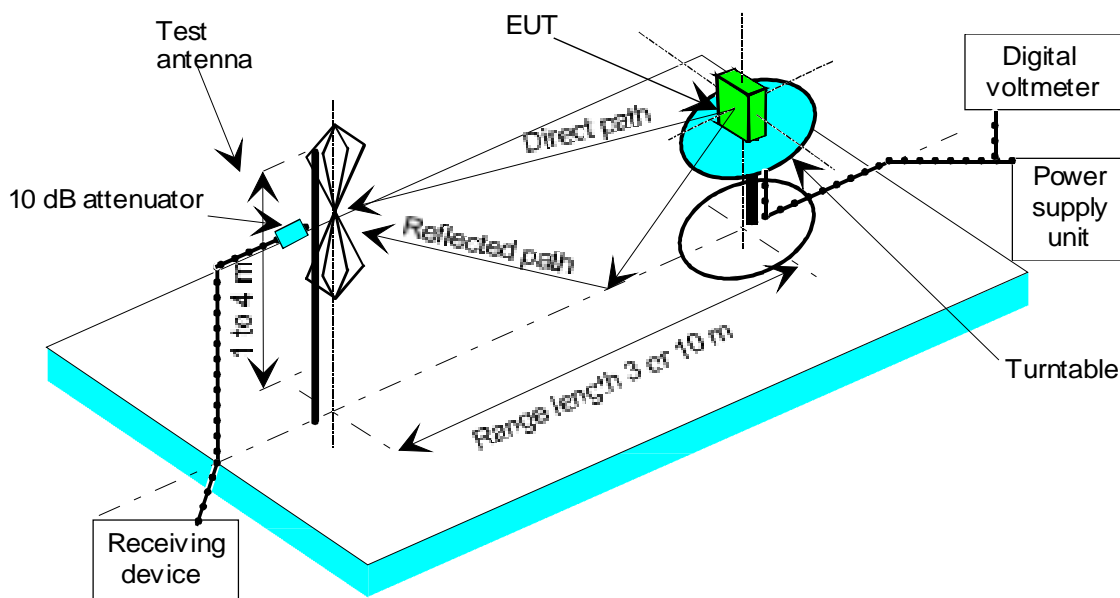

Figure A.4: Measuring arrangement on ground plane test site (OATS set-up for spurious emission testing)

A.1.4 Test antenna

A test antenna is always used in radiated test methods. In emission tests (i.e. frequency error, effective radiated power, spurious emissions and adjacent channel power) the test antenna is used to detect the field from the EUT in one stage of the measurement and from the substitution antenna in the other stage. When the test site is used for the measurement of receiver characteristics (i.e. sensitivity and various immunity parameters) the antenna is used as the transmitting device.

The test antenna should be mounted on a support capable of allowing the antenna to be used in either horizontal or vertical polarization which, on ground plane sites (i.e. Anechoic Chambers with ground planes and Open Area Test Sites), should additionally allow the height of its centre above the ground to be varied over the specified range (usually 1 m to 4 m).

In the frequency band 30 MHz to 1 000 MHz, dipole antennas (constructed in accordance with ANSI/IEEE C63.5 [7]) are generally recommended. For frequencies of 80 MHz and above, the dipoles should have their arm lengths set for resonance at the frequency of test. Below 80 MHz, shortened arm lengths are recommended. For spurious emission testing, however, a combination of bicones and log periodic dipole array antennas (commonly termed "log periodics") could be used to cover the entire 30 MHz to 1 000 MHz band. Above 1 000 MHz, waveguide horns are recommended although, again, log periodics could be used.

NOTE: The gain of a horn antenna is generally expressed relative to an isotropic radiator.

A.1.5 Substitution antenna

The substitution antenna is used to replace the EUT for tests in which a transmitting parameter (i.e. frequency error, effective radiated power, spurious emissions and adjacent channel power) is being measured. For measurements in the frequency band 30 MHz to 1 000 MHz, the substitution antenna should be a dipole antenna (constructed in accordance with ANSI/IEEE C63.5 [7]). For frequencies of 80 MHz and above, the dipoles should have their arm lengths set for resonance at the frequency of test. Below 80 MHz, shortened arm lengths are recommended. For measurements above 1 000 MHz, a waveguide horn is recommended. The centre of this antenna should coincide with either the phase centre or volume centre.

A.1.6 Measuring antenna

The measuring antenna is used in tests on a EUT in which a receiving parameter (i.e. sensitivity and various immunity tests) is being measured. Its purpose is to enable a measurement of the electric field strength in the vicinity of the EUT. For measurements in the frequency band 30 MHz to 1 000 MHz, the measuring antenna should be a dipole antenna (constructed in accordance with ANSI/IEEE C63.5 [7]). For frequencies of 80 MHz and above, the dipoles should have their arm lengths set for resonance at the frequency of test. Below 80 MHz, shortened arm lengths are recommended. The centre of this antenna should coincide with either the phase centre or volume centre (as specified in the test method) of the EUT.

A.2 Guidance on the use of radiation test sites

This clause details procedures, test equipment arrangements and verification that should be carried out before any of the radiated test are undertaken. These schemes are common to all types of test sites described in annex A.

A.2.1 Verification of the test site

No test should be carried out on a test site which does not possess a valid certificate of verification. The verification procedures for the different types of test sites described in annex A (i.e. Anechoic Chamber, Anechoic Chamber with a ground plane and Open Area Test Site) are given in ETR 273 [5] parts 2, 3 and 4, respectively.

A.2.2 Preparation of the EUT

The manufacturer should supply information about the EUT covering the operating frequency, polarization, supply voltage(s) and the reference face. Additional information, specific to the type of EUT should include, where relevant, carrier power, channel separation, whether different operating modes are available (e.g. high and low power modes) and if operation is continuous or is subject to a maximum test duty cycle (e.g. one minute on, four minutes off).

Where necessary, a mounting bracket of minimal size should be available for mounting the EUT on the turntable. This bracket should be made from low conductivity, low relative dielectric constant (i.e. less than 1,5) material(s) such as expanded polystyrene, balsawood, etc.

A.2.3 Power supplies to the EUT

All tests should be performed using power supplies wherever possible, including tests on EUT designed for battery-only use. In all cases, power leads should be connected to the EUT's supply terminals (and monitored with a digital voltmeter) but the battery should remain present, electrically isolated from the rest of the equipment, possibly by putting tape over its contacts.

The presence of these power cables can, however, affect the measured performance of the EUT. For this reason, they should be made to be "transparent" as far as the testing is concerned. This can be achieved by routing them away from the EUT and down to the either the screen, ground plane or facility wall (as appropriate) by the shortest possible paths. Precautions should be taken to minimize pick-up on these leads (e.g. the leads could be twisted together, loaded with ferrite beads at 0,15 m spacing or otherwise loaded).

A.2.4 Volume control setting for analogue speech tests

Unless otherwise stated, in all receiver measurements for analogue speech the receiver volume control where possible, should be adjusted to give at least 50 % of the rated audio output power. In the case of stepped volume controls, the volume control should be set to the first step that provides an output power of at least 50 % of the rated audio output power. This control should not be readjusted between normal and extreme test conditions in tests.

A.2.5 Range length

The range length for all these types of test facility should be adequate to allow for testing in the far-field of the EUT i.e. it should be equal to or exceed:

$$\frac{2(d_1 + d_2)^2}{\lambda}$$

where:

d_1 is the largest dimension of the EUT/dipole after substitution (m);

d_2 is the largest dimension of the test antenna (m);

λ is the test frequency wavelength (m).

It should be noted that in the substitution part of this measurement, where both test and substitution antennas are half wavelength dipoles, this minimum range length for far-field testing would be:

$$2\lambda$$

It should be noted in test reports when either of these conditions is not met so that the additional measurement uncertainty can be incorporated into the results.

NOTE 1: **For the fully Anechoic Chamber**, no part of the volume of the EUT should, at any angle of rotation of the turntable, fall outside the "quiet zone" of the chamber at the nominal frequency of the test.

NOTE 2: The "quiet zone" is a volume within the Anechoic Chamber (without a ground plane) in which a specified performance has either been proven by test, or is guaranteed by the designer/manufacture. The specified performance is usually the reflectivity of the absorbing panels or a directly related parameter (e.g. signal uniformity in amplitude and phase). It should be noted however that the defining levels of the quiet zone tend to vary.

NOTE 3: **For the Anechoic Chamber with a ground plane**, a full height scanning capability, i.e. 1 to 4 m, should be available for which no part of the test antenna should come within 1 m of the absorbing panels. For both types of Anechoic Chamber, the reflectivity of the absorbing panels should not be worse than -5 dB.

NOTE 4: **For both the Anechoic Chamber with a ground plane and the Open Area Test Site**, no part of any antenna should come within 0,25 m of the ground plane at any time throughout the tests. Where any of these conditions cannot be met, measurements should not be carried out.

A.2.6 Site preparation

The cables for both ends of the test site should be routed horizontally away from the testing area for a minimum of 2 m (unless, in the case both types of Anechoic Chamber, a back wall is reached) and then allowed to drop vertically and out through either the ground plane or screen (as appropriate) to the test equipment. Precautions should be taken to minimize pick up on these leads (e.g. dressing with ferrite beads, or other loading). The cables, their routing and dressing should be identical to the verification set-up.

NOTE: For ground reflection test sites (i.e. Anechoic Chambers with ground planes and Open Area Test Sites) which incorporate a cable drum with the antenna mast, the 2 m requirement may be impossible to comply with.

Calibration data for all items of test equipment should be available and valid. For test, substitution and measuring antennas, the data should include gain relative to an isotropic radiator (or antenna factor) for the frequency of test. Also, the VSWR of the substitution and measuring antennas should be known.

The calibration data on all cables and attenuators should include insertion loss and VSWR throughout the entire frequency range of the tests. All VSWR and insertion loss figures should be recorded in the log book results sheet for the specific test.

Where correction factors/tables are required, these should be immediately available.

For all items of test equipment, the maximum errors they exhibit should be known along with the distribution of the error e.g.:

- cable loss: $\pm 0,5$ dB with a rectangular distribution;
- measuring receiver: 1,0 dB (standard deviation) signal level accuracy with a Gaussian error distribution.

At the start of measurements, system checks should be made on the items of test equipment used on the test site.

A.3 Coupling of signals

A.3.1 General

The presence of leads in the radiated field may cause a disturbance of that field and lead to additional measurement uncertainty. These disturbances can be minimized by using suitable coupling methods, offering signal isolation and minimum field disturbance (e.g. optical and acoustic coupling).

A.3.2 Data Signals

Isolation can be provided by the use of optical, ultra sonic or infra red means. Field disturbance can be minimized by using a suitable fibre optic connection. Ultra sonic or infra red radiated connections require suitable measures for the minimization of ambient noise.

A.3.3 Speech and analogue signals

Where an audio output socket is not available an acoustic coupler should be used.

When using the acoustic coupler, care should be exercised that possible ambient noise does not influence the test result.

A.3.3.1 Acoustic coupler description

The acoustic coupler comprises a plastic funnel, an acoustic pipe and a microphone with a suitable amplifier. The materials used to fabricate the funnel and pipe should be of low conductivity and of low relative dielectric constant (i.e. less than 1,5).

- The acoustic pipe should be long enough to reach from the EUT to the microphone which should be located in a position that will not disturb the RF field. The acoustic pipe should have an inner diameter of about 6 mm and a wall thickness of about 1,5 mm and should be sufficiently flexible so as not to hinder the rotation of the turntable.
- The plastic funnel should have a diameter appropriate to the size of the loudspeaker in the EUT, with soft foam rubber glued to its edge, it should be fitted to one end of the acoustic pipe and the microphone should be fitted to the other end. It is very important to fix the centre of the funnel in a reproducible position relative to the EUT, since the position of the centre has a strong influence on the frequency response that will be measured. This can be achieved by placing the EUT in a close fitting acoustic mounting jig, supplied by the manufacturer, of which the funnel is an integral part.

- The microphone should have a response characteristic flat within 1 dB over a frequency range of 50 Hz to 20 kHz, a linear dynamic range of at least 50 dB. The sensitivity of the microphone and the receiver audio output level should be suitable to measure a signal to noise ratio of at least 40 dB at the nominal audio output level of the EUT. Its size should be sufficiently small to couple to the acoustic pipe.
- The frequency correcting network should correct the frequency response of the acoustic coupler so that the acoustic SINAD measurement is valid (see IEC 60489-3 [8], appendix F).

A.3.3.2 Calibration

The aim of the calibration of the acoustic coupler is to determine the acoustic SINAD ratio which is equivalent to the SINAD ratio at the receiver output.

Annex B (normative): Specification for some particular measurement arrangements

B.1 Power measuring receiver specification

The power measuring receiver consists of a mixer, an IF filter, an oscillator, an amplifier, a Variable attenuator and a root mean squared (rms) value indicator.

Instead of the Variable attenuator with the rms value indicator it is also possible to use a rms Voltmeter calibrated in dB. The technical characteristics of the power measuring receiver are given below.

An alternative measuring method shall consist in using, in place of the IF filter and the rms Voltmeter calibrated in dB, a spectrum analyser with a resolution bandwidth of 100 Hz and integrating the power of all the 100 Hz sub-band measurements, over a total bandwidth of $\pm D2$ (see table B.1).

B.1.1 IF filter

The IF filter shall be within the limits of the selectivity characteristic of figure B.1.

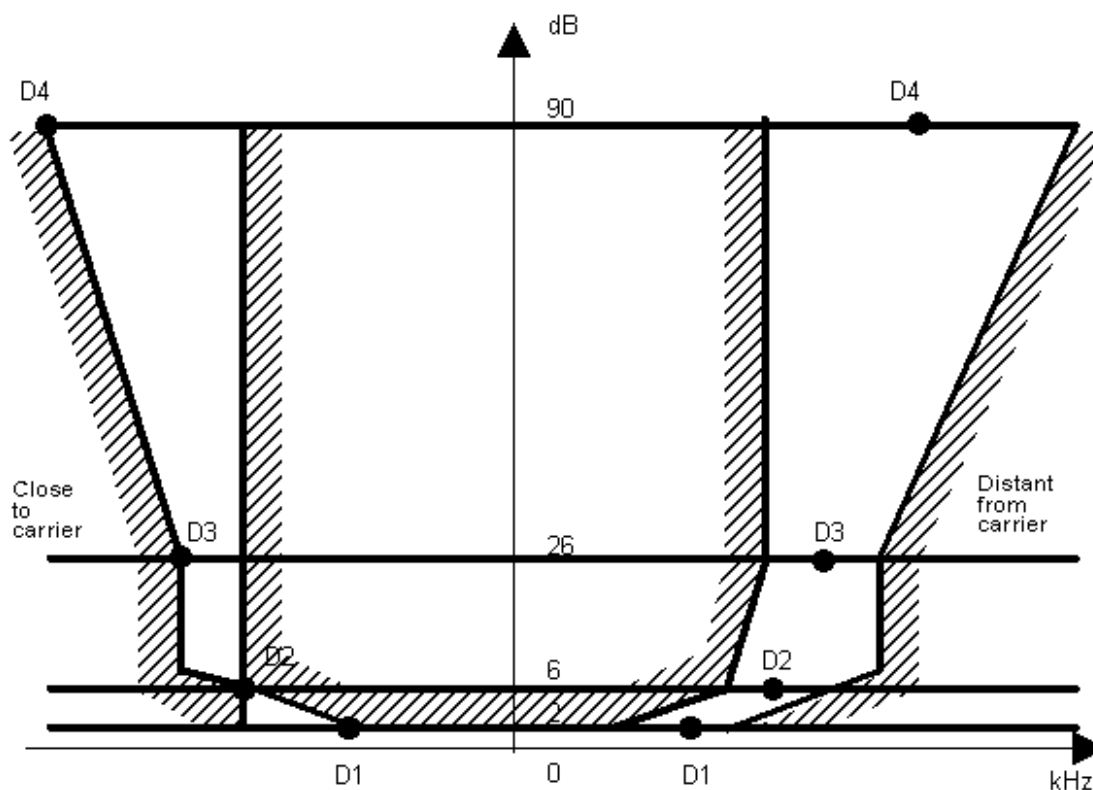

Figure B.1: IF filter

Depending on the channel separation, the selectivity characteristic shall keep the frequency separations from the nominal centre frequency of the adjacent channel as stated in table B.1.

Table B.1: Selectivity characteristic

Channel separation (kHz)	Frequency separation of filter curve from nominal centre frequency of adjacent channel (kHz)			
	D1	D2	D3	D4
12,5	3	4,25	5,5	9,5
20	4	7,0	8,25	12,25
25	5	8,0	9,25	13,25

Depending on the channel separation, the attenuation points shall not exceed the tolerances as stated in tables B.2 and B.3.

Table B.2: Attenuation points close to carrier

Channel separation (kHz)	Tolerances range (kHz)			
	D1	D2	D3	D4
12,5	+1,35	±0,1	-1,35	-5,35
20	+3,1	±0,1	-1,35	-5,35
25	+3,1	±0,1	-1,35	-5,35

Table B.3: Attenuation points distant from the carrier

Channel separation (kHz)	Tolerance range (kHz)			
	D1	D2	D3	D4
12,5	±2,0	±2,0	±2,0	+2,0 -6,0
20	±3,0	±3,0	±3,0	+3,0 -7,0
25	±3,5	±3,5	±3,5	+3,5 -7,5

The minimum attenuation of the filter, outside the 90 dB attenuation points, shall be greater than or equal to 90 dB.

B.1.2 Attenuation indicator

The attenuation indicator shall have a minimum range of 80 dB and a reading accuracy of 1 dB. With a view to future regulations, an attenuation of 90 dB or more is recommended.

B.1.3 rms value indicator

The instrument shall accurately indicate non-sinusoidal signals in a ratio of up to 10:1 between peak value and rms value.

B.1.4 Oscillator and amplifier

The oscillator and the amplifier shall be designed in such a way that the measurement of the adjacent channel power of a low-noise unmodulated transmitter, whose self-noise has a negligible influence on the measurement result, yields a measured value of ≤ -90 dB for channel separations of 20 kHz and 25 kHz and of ≤ -80 dB for a channel separation of 12,5 kHz, referred to the carrier of the oscillator.

B.2 Spectrum analyser specification

The specification shall include the following requirements.

It shall be possible, using a resolution bandwidth of 1 kHz, to measure the amplitude of a signal, or noise at a level 3 dB or more above the noise level of the spectrum analyser, as displayed on the screen, to an accuracy of ± 2 dB in the presence of the wanted signal.

The accuracy of relative amplitude measurements shall be within ± 1 dB.

For statistically distributed modulations, the spectrum analyser and the integrating device (when appropriate) shall allow determination of the real spectral power density (energy per time and bandwidth), which has to be integrated over the bandwidth in question.

NOTE: This point should be considered very carefully.

B.3 Integrating and power summing device

The integrating and power summing device is connected to the video output of the spectrum analyser, referred to in clause B.2.

It shall be possible to sum the effective power of all discrete components, the spectral power density and the noise power in the selected bandwidth and to measure this as a ratio relative to the carrier power.

The position and the width of the integration range selected can be indicated on the spectrum analyser by brightening the trace.

Annex C (normative): Identification

The requirements set out in this annex are optional. This annex presents the technical characteristics to be fulfilled, when required by the appropriate national regulatory authority, for the identification of stations for private mobile radio systems, that do not comply with other system protocols (e.g. trunking protocols); it is the responsibility of the manufacturer to ensure that the modulation that he has chosen for the identification, in accordance with the tables of this annex fulfils the requirements corresponding to the channels where the equipment is designed to operate, as specified in the main body of the present document. The tables of this annex are expected to be updated regularly in order to reflect the progress accomplished in the field of mobile data transmissions.

C.1 Scope

The identification code should fulfil the specifications given in this annex unless identification is included in a system protocol approved by the appropriate Administration. It should also be used by combined speech/non speech equipment in the case of speech transmissions.

C.2 General

The design of a mobile system depends upon the requirements of that system, the evolution of technology and the specific needs and/or requirements of each country or region. When possible, the transmission of the identification code (ID) would use the same techniques as the transmission of the user information itself. Therefore, a variety of possibilities have been specified in this annex. They are presented using several item tables and/or cross-tables:

- modulation (indicating speed, channel separation and modulation): see table C.1;
- bitsync (if needed) and synchronization word: see table C.2;
- redundancy code (Forward Error Correction (FEC)) and length of the useful bits protected by that code (e.g. Cyclic Redundancy Code (CRC)): see table C.3;
- header of the ID (length and contents should be unique to avoid ambiguous situations): see table C.4;
- country or regional code and length of national or regional information: see table C.5;
- national/regional information subdivided in fields: table C.6 (table C.7 and figures C.2 to C.6);
- combinations of the previous items that could be used: see table C.8;
- combinations of the previous items that will in fact be used in the various countries or regions: see table C.9;
- organization of the fields that will in fact be used in the various countries or regions: see table C.10.

These tables can be used by manufacturers for the design of the equipment, by the monitoring stations for the analysis of the identification of the transmissions and for testing purposes.

It is the responsibility of the manufacturer to ensure that the modulation that he has chosen for the identification, in accordance with the tables of this annex, fulfils the requirements corresponding to the channels where the equipment is designed to operate, as specified in the main body of the present document.

C.3 Position of the identification code

Considering that a receiver in the monitoring service is often operated in scanning mode and stops on a detected carrier, the identification code will be transmitted as described below.

C.3.1 Base stations

For base stations, the identification, ID, should be transmitted at the beginning and end of each session, at the end of the corresponding packets. If the session lasts for more than three minutes, an ID will also be transmitted at the end of the first transmitted packet after the moment when 3 minutes have elapsed since the last transmission of the ID (this is the "3 minutes rule"). There is no need for more than one ID per packet, unless 3 minutes have elapsed since the last transmission of the ID.

C.3.1.1 System without windows

In the case of continuous transmissions, the "3 minutes rule" should apply (not more than 3 minutes between transmissions of the ID).

C.3.1.2 Systems with windows

In the case of windows of less than 3 minutes, the ID should also be sent at the end of the first packet of each window.

In the case of windows of more than 3 minutes, the ID should, in addition, be sent according to the "3 minutes rule".

C.3.2 Mobile stations

The same rule as for the base stations applies except that a mobile only transmitting to a Base Station (BS) with a transmission shorter than 300 ms (e.g. the duration of a data burst), does not have to transmit its ID systematically in each session. Instead, the 3 minute rule applies, as follows:

- the ID should be sent at the end of the first packet to be sent after the moment when 3 minutes have elapsed since the last transmission of the ID.

C.4 Bit rates and modulations

Using table C.1, demodulation can be performed, producing a bit stream.

In the case of sub-carrier modulation (indirect modulation), the carrier can be modulated in phase (/ph.) or frequency (/frq.).

Table C.1: Bit rate and modulation schemes

Name	Bit Rate (b/s)	Channel separation (kHz)	Modulation (or reference)	Details (or reference)
MM12n /ph. /frq.	1 200	12,5	MSK (FFSK)	0 = 1 800 Hz, 1 = 1 200 Hz
MM12w /ph. /frq.	1 200	20/25	MSK (FFSK)	0 = 1 800 Hz, 1 = 1 200 Hz
MV22w	1 200	20/25	ITU-T Recommendation V 22	4 phase state
MV23w	1 200	20/25	ITU-T Recommendation V 23	0 = 2 100 Hz, 1 = 1 300 Hz
MM24n	2 400	12,5	MSK (FFSK)	0 = 2 400 Hz, 1 = 1 200 Hz
MM24w	2 400	20/25	MSK (FFSK)	0 = 2 400 Hz, 1 = 1 200 Hz
MD24n	2 400	12,5	Direct	
MD24w	2 400	20/25	Direct	
MM36n	3 600	12,5	MSK (FFSK)	0 = 3 600 Hz, 1 = 1 800 Hz
MM36w	3 600	20/25	MSK (FFSK)	0 = 3 600 Hz, 1 = 1 800 Hz
MD36n	3 600	12,5	Direct	
MD36w	3 600	20/25	Direct	
MM48n	4 800	12,5	MSK (FFSK)	0 = 4 800 Hz, 1 = 2 400 Hz
MM48w	4 800	20/25	MSK (FFSK)	0 = 4 800 Hz, 1 = 2 400 Hz
MD48n	4 800	12,5	Direct	
MD48w	4 800	20/25	Direct	
MD72n	7 200	12,5	Direct	
MD72w	7 200	20/25	Direct	
MD80n	8 000	12,5	Direct	
MD80w	8 000	20/25	Direct	
MD96n	9 600	12,5	Direct	
MD96w	9 600	20/25	Direct	
MD160	16 000	(20)/25	Direct	
MD192	19 200	25	Direct	
NOTE 1: The direct modulation concerns constant envelope modulation or non constant envelope modulation methods and includes: GMSK, generalized tamed FM, multilevel state FM, PLL-4-PSK, 8 PSK, QAM, OQAM, OQPSK, etc.				
NOTE 2: Other modulation systems are under consideration and may be added later to this table if proven to provide better performance.				
NOTE 3: The frequency shift used with the direct FSK modulation should be chosen to meet clause 8.5 (adjacent channel transmitter power).				
NOTE 4: Some modulation methods presented in this table have not yet been proven to meet clause 8.5 (adjacent channel transmitter power).				

C.5 Format of the identification

The identification, ID, should be transmitted in one block (see definitions in clause 3.1).

If bit rate/modulation used to transmit "user's information" and of the "ID block" are not the same, the "ID block" should be preceded by "bit sync".

If bit rate and modulation are the same, the "bit sync" is optional. However, it is well known that the auto-correlation properties of the "sync words" are calculated with respect to their corresponding "bit sync" (see table C.2).

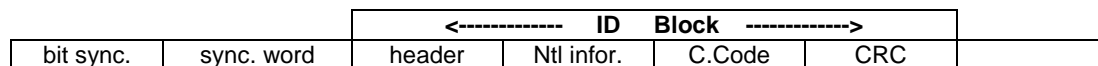

Figure C.1: ID block organization

C.6 Synchronization

Using table C.2, the monitoring station receiver/decoder can be synchronized (detection of the beginning of each block) and bits can be extracted from the bit stream. Bits should be transmitted in the order of Most Significant Bit (MSB) first.

Table C.2: Synchronization

Bit sync (if needed)	Sync. word		Notes
	name	value	
1010 1010 1010 1010	S1	1011 0100 0011 0011	note 1
1010 1010 1010 1010	S2	0011 1011 0010 1000	
10 10 10 10	S3	1100 1110 00	note 2
01 01 01 01	S3'	0011 0001 11	note 2
1010 1010 1010 1010	S4	1100 0100 1101 0111	
1010 1010 1010 1010	S5	(1)010 0010 1111 0111	
	S6	(1)101 1101 0000 1000	
1010 1010 1010 1010	S7	1010 1111 0001 0010	
NOTE 1: This sync word has optimal auto-correlation properties.			
NOTE 2: Frame synchronization comprises 10 bits with the structure: S3 = transmissions Base to Hand portable/Mobile; S3' = transmissions Hand portable/Mobile to Base. Only these 10 bits are used for frame synchronization when hand portables or mobiles evaluate base stations. These 10 bits plus base identity (10 bits) in the scheme apply to all other communication with the current base as synchronization word for frame synchronization. Furthermore, four control flags are included in the synchronization word, i.e. the total length of the frame head is: 24 bits + bit sync.			

NOTE: Table C.2 is valid in the case of modulations for which 101010 is an effective bit sync pattern. In the case of direct modulation methods for which the patterns given in table C.2 are not appropriate, the way in which entries of table C.2 have to be adapted to the constraints of a particular type of modulation, is to be agreed by the appropriate Administration.

C.7 Code and block length

Using table C.3, the "useful" bits of each block can be counted and checked (error detection can be performed). Corrections could also be performed: a trade-off between detection and correction performance and notes concerning the code are proposed in column "Det/Corr" (information concerning detection/correction).

Table C.3: Code and block length

Name	Sizes	Notes	Details	Det/Corr
C1	(64,48)		$X^{15} + X^{14} + X^{13} + X^{11} + X^4 + X^2 + 1$ cyclic (63,48), LSB inv. +1 parity (even) bit appended	Det = < 5 errors
C2	(n+8,n)		$X^8 + X^7 + X^4 + 1$ all bits	
C3	(69,48)		Shortened cyclic	Det/Corr
C4	(16,8)	note 1	Block code: Corr 2 er.	
OC1	16 x (8,4)	note 2	for "overcoding" the block in certain frequency bands parity check matrix: (01 --- --) (10 01 -- --) (10 10 01 --) (00 10 10 01)	Corr 2 err.
NOTE 1: Code C4 may be used in systems which need high protection and with a small amount of data to be transferred in a normal transmission. (6 blocks are needed to transmit the ID).				
NOTE 2: Code OC1, in some frequency bands, may be used to protect all the bits of the block (in order to allow the correction of errors due to ignition noise, etc.). In the case where the code OC1 is used, the code C1 should only be used for error detection.				

C.8 Contents of the identification block

C.8.1 Header

Using table C.4, the nature of the information contained in one particular block can be determined as ID or users/system information.

Many of the combinations in this header are free for other use. Using such an organization could allow systems using only one block for the ID to use the first bit of the blocks as an "ID/information flag" (user/system), while leaving it open for others to use more bits.

For hunting purposes, the bits of the header could also be considered as part of the sync word.

Table C.4: Header information

Name	Length	Binary	Interpretation
H1	4 bits	Hn2 = 0 0 x x	ID word to be used during the session (monitored on F1 or F2)
		Hn1 = 0 1 x x	ID word transmitting on F1; it can be used to activate the corresponding repeater
		Hd = 1 y x x	user/system information block; bits y and x are free for future use or for transmitting user/system information
NOTE: When a repeater is used, "F1" is the frequency used for the mobiles to transmit, "F2" is the output frequency of the repeater.			

C.8.2 Country/regional code

Table C.5 allows for the transcoding of the 5 bit CC field into the country or region to which the ID has been allocated.

The codes found in this table have originally been allocated so that the codes corresponding to regions close to each other are separated by a large Hamming distance (i.e. many bits are different). Table C.5 has been subsequently expanded in such a way to ensure "upwards compatibility".

Table C.5: Country codes

Country code	Country	Length of Ntl info (if deviating from 39 bits) (clause C.8.3)
00 000	Others	
01 111	Germany (Fed. Rep.)	41 bits
01 110	Andorra	(note 2)
11 001	Austria	
10 110	Baltic Republics	(note 2)
00 110	Bulgaria	(note 2)
01 100	Belgium	
11 101	Croatia	(note 2)
00 100	Cyprus	
00 011	Czech Republic	(note 2)
01 000	Denmark	
10 111	Spain	
01 110	Faroe Islands	(note 2)
01 011	Finland	
10 000	France	
10 011	Russia and countries from IEC not explicitly quoted in the table	
00 111	Greece	
00 110	Hungary	(note 2)
11 110	Ireland	
11 000	Iceland	
01 010	Italy	
11 010	Liechtenstein	
11 011	Luxembourg	
11 101	Malta	(note 2)
11 111	Monaco	
01 101	Norway	
10 001	Netherlands	
10 101	Poland	
00 010	Portugal	
00 110	Romania	(note 2)
01 001	United Kingdom	
10 110	San Marino	(note 2)
00 011	Slovak Republic	(note 2)
11 101	Slovenia	(note 2)
10 010	Sweden	
00 101	Switzerland	
11 100	Turkey	
00 001	Vatican (City)	
10 100	Countries from ex-Yugoslavia not explicitly quoted in the table	
NOTE 1: In the allocation some codes are missing due to recent developments in Europe; table C.5 will be completed when possible in the future.		
NOTE 2: Two or more countries can use the same 5 bit CC code in which case the differentiation can be made using the LOF field ("Regional Licensing Office").		
NOTE 3: When mobiles from two or more countries are not expected to interfere with each other, then these countries can use the same 5 bit CC code.		

C.8.3 National Information

The following options for the fields containing the "National" (Ntl) information are based on the assumption that the ID blocks contain 48 useful bits and provide 39 bits for the "National" information field ("Ntl info" or field F).

C.8.3.1 Field description

The fields shown in table C.6 can either be used for the purpose of identification and/or used for transmitting information corresponding to user data or system needs.

Table C.6: Field description

Category	No of bits
Licensee number	Lnb: 0 - 14
Individual transmitter identification	TID: 0 - 20
Network identification	NID:14 - 20
Regional licensing office	LOF: 0 - 8
Relay station number	Rnb: 0 - 12
National Additional information	NAI: 0 - 20
User group	UG: 0 - 7
Field free for system or user data	FF:

The maximum total number of bits available in field F is 39 bits (however national information can go up to 41 bits by overflow of 2 bits into the header Hxx bits).

All categories are expected to be coded in binary (and will be presented in 4 bit nibbles).

C.8.3.2 Field size options

Table C.7: Field size options

Name of the scheme	Field description		
	Size	Name	Usage
FZ1	7 bits	LOF	regional licensing office ID
	7 bits	UG	user group
	14 bits	NID	network identification
	13 bits	TID	individual transmitter ID
FZ2	5 bits	Rnb	relay number
	18 bits	NID	network ID
	12 bits	TID	individual mobile number
FZ3	27 bits	Lnb	licensee number
	14 bits	NID	network ID

C.8.3.3 Options for the organization of the fields

Figures C.2 to C.6 show possible organizations of the fields within the "ID block".

* bit	0	2	9	13	16	30	43
sync word	H Oy	UG 7 bits	LOFM 4 bits	LOFL 3 bits	NID 14 bits	TID 13 bits	CC 5 bits

Figure C.2: FO1

bit	0	4	9	13	31	43
sync word	H Oyxx	Rnb 5 bits	FF 4 bits	NID 18 bits	TID 12 bits	CC 5 bits

Figure C.3: FO2

bit	0	2	29	43
sync word	H Oy	Lnb 27 bits	NID 14 bits	CC 5 bits

Figure C.4: FO3

bit	0	4	9	36	43
sync word	H Obxx	FF 5 bits	Lnb 27 bits	NID 7 bits	CC 5 bits

Figure C.5: FO3b

bit	0	4	9	13	17	31	43
sync word	H Obxx	Rnb 5 bits	FF 4 bits	Ext 4 bits	NID 14 bits	TID 12 bits	CC 5 bits

Figure C.6: FO4

Option F04, given in figure C.6 above, is a common representation where the field extension ("Ext": 4 bits) could be either FF or LOF(L) or an extension for NID.

C.8.3.4 Examples of user/system information usage

The bits of the ID block that have not been allocated in table C.6 (free fields "FF") can be:

- used for numbering the blocks in the packets (e.g. 3 bits);
- used as a function code (e.g. 2 bits);
- used for the transmission of status;
- used to transmit an acknowledge;
- used to transmit a no-acknowledge;
- used to clear down the repeater (deactivation of the repeater after an activation using, for instance, Header code Hn1).

C.9 Combinations

Tables C.8 and C.9 indicate which of the combinations given in the "Items Tables" will in fact be used.

C.9.1 List of possible combinations

Table C.8 indicates the "lower layer" combinations that have been explicitly supported by the regulatory authorities and that could be accepted in some countries. Knowing these formats and codes, "Ntl information" can be easily accessed.

Table C.8: Combinations table

Modulation	Sync. word	Code length	Header	Freq.Band	Comb. name + notes
MM12w	S1	C1	H1(w/2bit)		ACx
MM12n	S1	C1	H1	< 500 MHz	ACy
MM12n,w	S3 + S3'	C3	H1	< 1 000 MHz	ACzn, ACzw
MM12n,w	S7	C4	H1	< 500 MHz	ACtn, ACTw
NOTE: To be completed in the future.					

C.9.2 Relations between country/regional code and allowed combinations

Table C.9 indicates, among the combinations included in table C.8, those which are, or will soon be, effectively allowed in the different countries or regions.

Table C.9: Combinations in a country

Country code	Allowed combinations	Notes
D 01 111	ACx, Fs	Not all combinations will be allowed
And 01 110		
A 11 001		
B 01 100		
CY 00 100		
DK 01 000	Fs	
E 10 111	Fs	
SF 01 011	Fs	
F 10 000	ACy	Until further notice, only one is allowed
GR 00 111		
IRL 11 110		
IS 11 000		
I 01 010	Fs	
FL 11 010		
L 11 011		
M 11 101		
MC 11 111		
N 01 101	Fs	
NL 10 001	Fs	In the future only a few combinations will be allowed
P 00 010	Fs	
GB 01 001	ACy	Other combinations may be allowed
SMR 10 110		
S 10 010	ACzw, ACTw	Other combinations may be allowed
CH 00 101	Fs	
TR 11 100		
SCV 00 001		
YU 10 100		
NOTE: Fs: further study is needed.		

C.9.3 Interpretation of the fields of the ID block

Using table C.10, interpretation of the various fields could be performed.

Table C.10: Interpretation table

Country code		Scheme for organization of NTL info (note 2)
D	01 111	Z1/F01
And	01 110	
A	11 001	
B	01 100	
CY	00 100	
DK	01 000	Fs (note 1)
E	10 111	Fs
SF	01 011	Fs
F	10 000	FZ2/F02, equivalent to F04 with EXT used for extension of NID
GR	00 111	
IRL	11 110	
IS	11 000	
I	01 010	Fs
FL	11 010	
L	11 011	
M	11 101	
MC	11 111	
N	01 101	
NL	10 001	
P	00 010	
GB	01 001	
SMR	10 110	
S	10 010	Fs
CH	00 101	
TR	11 100	
SCV	00 001	
YU	10 100	
NOTE 1: Fs: further study is needed.		
NOTE 2: For NTL information see clause C.8.3, including tables C.6 and C.7 and figures C.2 to C.6.		

Annex D (normative): Graphical representation of the selection of equipment and frequencies for testing

Information regarding the selection of equipment for testing purposes can be found in EN 300 793 [3].

The following graphs, imported from EN 300 793 [3], illustrate the principles used in that standard, in particular, concepts such as full and limited tests. For further details concerning the present annex (e.g. definitions, references), please, refer to EN 300 793 [3].

D.1 Tests on a single sample

If the Operating Frequency Range (OFR) of each equipment corresponds to its alignment range (AR0, AR1, AR2, or AR3) then only one sample shall be tested.

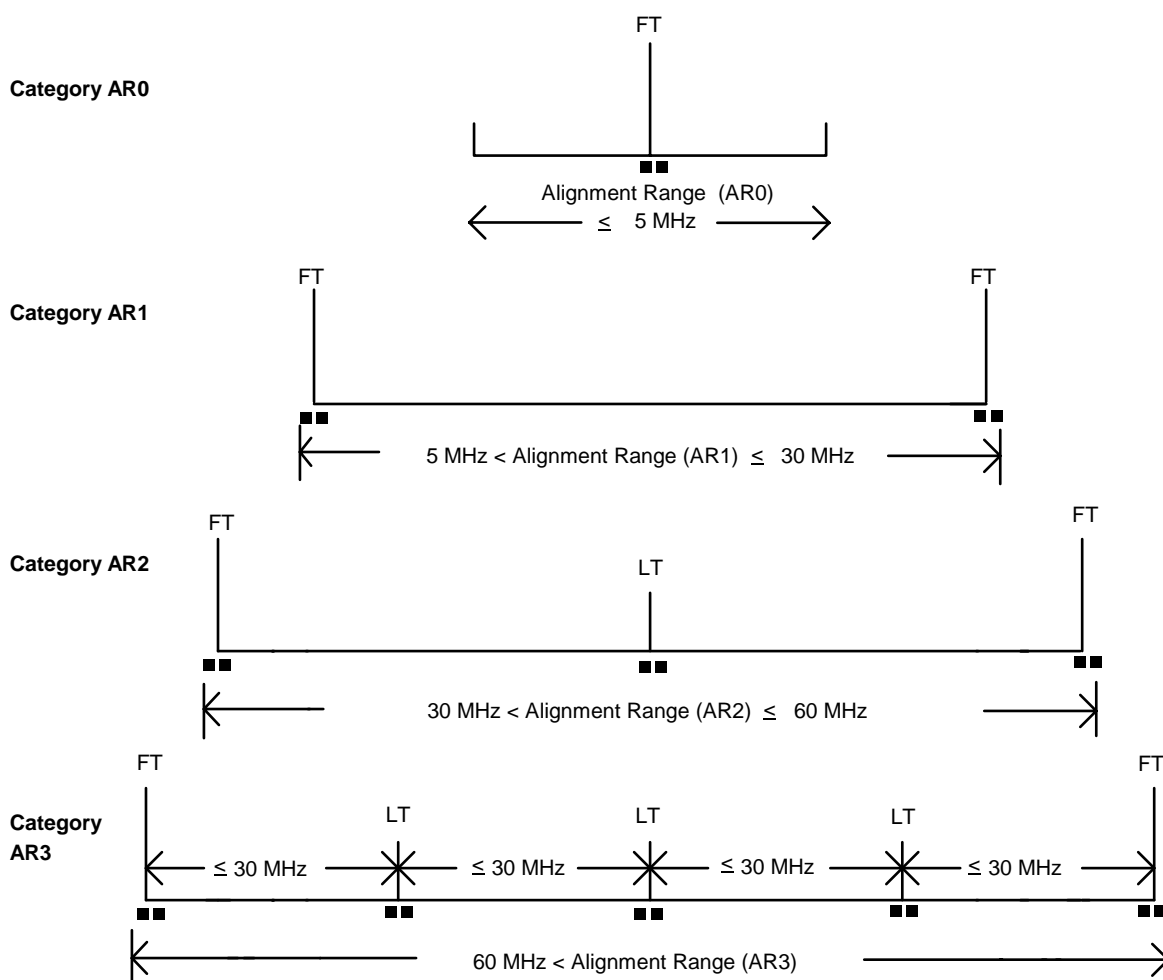

NOTE:

AR0, AR1, AR2, AR3: Categories of alignment range, see clause 4.3 in EN 300 793 [3].

FT: Full tests.

LT: Limited tests.

■ ■: 50 kHz range in which tests are carried out.

Figure D.1: Tests on a single sample for equipment that has a switching range equal to its alignment range

D.2 Tests and samples needed when the switching range is a subset of the alignment range

In order to cover an alignment range several separate samples, having different switching ranges (SR) within the alignment range, may be needed. Samples shall be then provided for testing in accordance with clauses 4.4, 4.5, 4.6, and 4.7 in EN 300 793 [3], as appropriate. The following examples assume a switching range (SR) of 5 MHz.

Category AR1



2 Samples, 2 FT

Category AR2

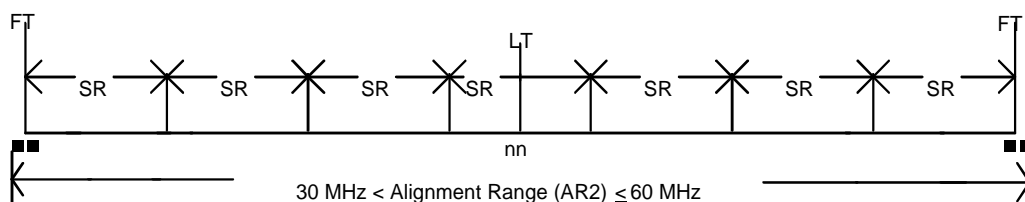

3 Samples, 2 FT, 1 LT.

Category AR3

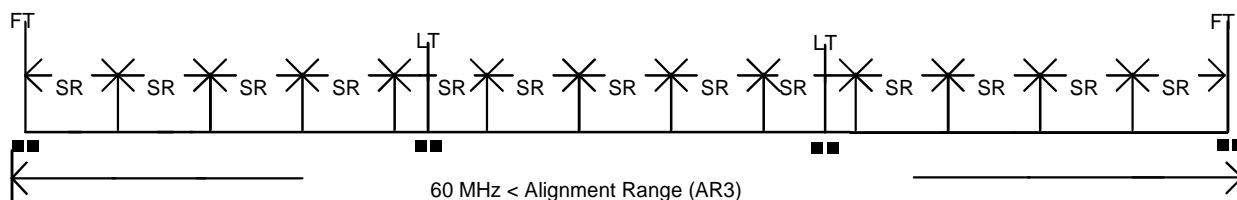

4 Samples, 2 FT, 2 LT.

NOTE:

- SR: Switching Range, see clause 4.2 in EN 300 793 [3].
- AR1, AR2, AR3: Categories of alignment range, see clause 4.3 in EN 300 793 [3].
- FT: Full tests.
- LT: Limited tests.
- ■: 50 kHz range in which tests are carried out.

Figure D.2: Tests on equipment having switching ranges that are subsets of their alignment range

D.3 Tests and samples for a family of equipment where the alignment range is a subset of the total operating frequency range

If the alignment range of a piece of equipment is a subset of the total operating frequency range then the operating frequency range shall be divided into appropriate categories of alignment range. Samples shall be then provided for testing in accordance with clauses 4.4, 4.5, 4.6, and 4.7 of EN 300 793 [3], as appropriate.

For example the applicant seeks type approval for a family of equipment having an operating frequency range of 403 MHz to 470 MHz. The equipment to be tested does not cover this range with one category of alignment range.

D.3.1 Test scenario 1

The Operating Frequency Range (OFR) could be covered by two alignment ranges a) and b), implemented in samples a) and b):

- a) 403 MHz to 430 MHz: This is category AR1;
- b) 425 MHz to 470 MHz: This is category AR2.

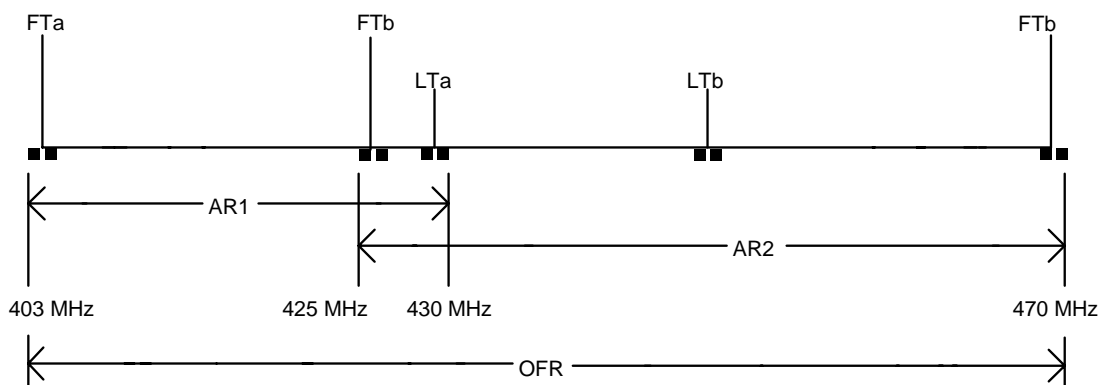

NOTE 1:

- OFR: Operating Frequency Range, see clause 4.2 in EN 300 793 [3].
- AR1, AR2: Categories of alignment range, see clause 4.3 in EN 300 793 [3].
- FTa: Full tests on sample(s) a).
- LTa: Limited tests on sample(s) a).
- FTb: Full tests on sample(s) b).
- LTb: Limited test on sample(s) b).
- ■: 50 kHz range in which tests are carried out.

NOTE 2: This example requires a minimum of two test samples and a maximum of five test samples to cover the operating frequency range.

Figure D.3: Tests on family member equipment having alignment ranges that are subsets of the total operating frequency range (example 1)

D.3.2 Test scenario 2

The Operating Frequency Range (OFR) could alternatively be covered by three alignment ranges of category AR1, implemented in samples a), b) and c):

- a) 403 MHz to 430 MHz: this is category AR1;
- b) 425 MHz to 450 MHz: this is category AR1;
- c) 450 MHz to 470 MHz: this is category AR1.

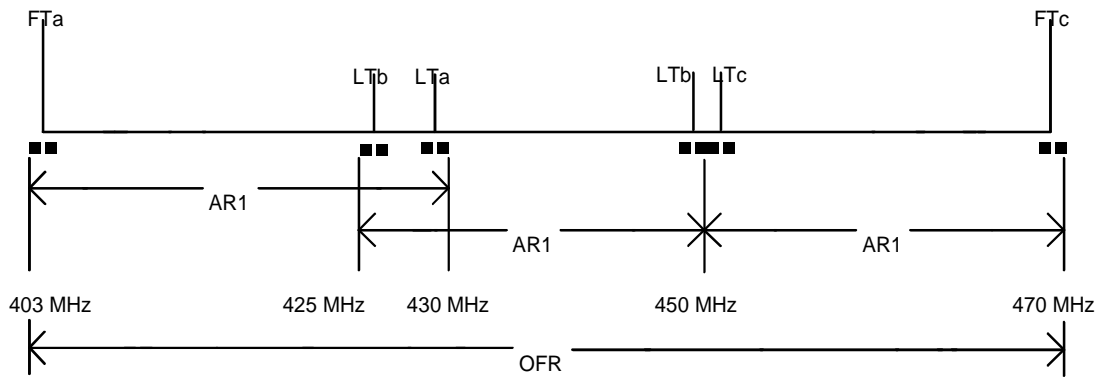

NOTE 1:

- OFR: Operating Frequency Range, see clause 4.2 in EN 300 793 [3].
 AR1: Second category of alignment range, see clause 4.3 in EN 300 793 [3].
 FTa: Full tests on sample(s) a).
 LLa: Limited tests on sample(s) a).
 LTb: Limited test on sample(s) b).
 FTc: Full tests on sample(s) c).
 LTc: Limited tests on sample(s) c).
 ■: 50 kHz range in which tests are carried out.

NOTE 2: This example requires a minimum of three test samples and a maximum of six test samples to cover the operating frequency range.

Figure D.4: Tests on family member equipment having alignment ranges that are subsets of the total operating frequency range (example 2)

Annex E (informative): Information on modulation, coding and format

It is pointed out that the present document addresses only the minimum performance of the hardware/lower layers of the data equipment and that it does not cover measurements that confirm the bit error ratio performance of the radio data systems in real or simulated mobile environment conditions (multipath fading, burst interference, ignition noise, etc.).

Attention is drawn to the fact that ITU-T Recommendations do not address the mobile system bit error ratio issue. Therefore equipment designed to meet such standards is not necessarily suitable for use in mobile radio systems. Specifically external modems, protocols and also ancillary units used in conjunction with mobile radio equipment should be capable of operating with the mobile radio system in such a manner as to minimize the system bit error ratio in real conditions, and to provide good spectrum efficiency.

Attention is also drawn to the availability of ITU-R Recommendations and reports on the subject (see old CCIR Volume VIII).

Furthermore, it is recommended to obtain the approval of the mobile radio manufacturer of any equipment to be incorporated in a mobile radio data system (e.g. in "OEM" basis).

Annex F (informative): Bibliography

COST 207 final report, Brussels 1989.

Directive 1999/5/EC of the European Parliament and of the Council of 9 March 1999 on radio equipment and telecommunications terminal equipment and the mutual recognition of their conformity (R&TTE Directive).

Council Directive 89/336/EEC of 3 May 1989 on the approximation of the laws of the Member States relating to electromagnetic compatibility (EMC Directive).

ETSI EN 300 219: "Electromagnetic compatibility and Radio spectrum Matters (ERM); Land mobile service; Technical characteristics and test conditions for radio equipment transmitting signals to initiate a specific response in the receiver".

ETSI EN 300 113: "Electromagnetic compatibility and Radio spectrum Matters (ERM); Land mobile service; Technical characteristics and test conditions for radio equipment intended for the transmission of data (and speech) and having an antenna connector".

ETSI EN 300 296: "Electromagnetic compatibility and Radio spectrum Matters (ERM); Land mobile service; Technical characteristics and test conditions for radio equipment using integral antennas intended primarily for analogue speech".

ETSI EN 300 341: "Electromagnetic compatibility and Radio spectrum Matters (ERM); Land mobile service; Technical characteristics and test conditions for radio equipment using an integral antenna transmitting signals to initiate a specific response in the receiver".

ETSI EN 301 166: "Electromagnetic compatibility and Radio spectrum Matters (ERM); Land mobile service; Technical characteristics and test conditions for radio equipment for analogue and/or digital communication (speech and/or data) and operating on narrowband channels and having an antenna connector".

CEPT Recommendation T/R 24-01: "Specifications of equipment for use in the Land Mobile Service".

CEPT/ERC/DEC(96)07: "ERC Decision of 1 November 1996 on the adoption of approval regulations for radio equipment to be used in the land mobile service intended for the transmission of data (and speech) and having an antenna connector, based on the European Telecommunications Standard (ETS) 300 113".

ITU-T Recommendation O.41: "Psophometer for use on telephone-type circuits".

ITU-T Recommendation V.22: "1 200 bits per second duplex modem standardized for use in the general switched telephone network and on point-to-point 2-wire leased telephone-type circuits".

ITU-T Recommendation V.23: "600/1 200-baud modem standardized for use in the general switched telephone network".

CEPT/ERC/DEC(97)10: "ERC Decision of 30 June 1997 on the mutual recognition of conformity assessment procedures including marking of radio equipment and radio terminal equipment".

CEPT/ERC/REC 01-06: "Procedure for mutual recognition of type testing and type approval for radio equipment".

History

Document history		
Edition 1	January 1992	Publication as I-ETS 300 113
Edition 2	June 1996	Publication as ETS 300 113
Amendment 1	March 1997	Amendment 1 to 2 nd Edition of ETS 300 113
V1.3.1	March 2001	Publication
V1.4.1	July 2001	Public Enquiry PE 20011109: 2001-07-11 to 2001-11-09
V1.4.1	December 2001	Vote V 20020215: 2001-12-17 to 2002-02-15