

**Access and Terminals (AT);
Public Switched Telephone Network;
Support of legacy terminals
by Broadband IP networks and equipment;
Part 2: Analogue PSTN terminals**



Reference

REG/AT-040005-02

Keywords

access, analogue, broadband, IP, multimedia,
terminal, PSTN

ETSI

650 Route des Lucioles
F-06921 Sophia Antipolis Cedex - FRANCE

Tel.: +33 4 92 94 42 00 Fax: +33 4 93 65 47 16

Siret N° 348 623 562 00017 - NAF 742 C
Association à but non lucratif enregistrée à la
Sous-Préfecture de Grasse (06) N° 7803/88

Important notice

Individual copies of the present document can be downloaded from:

<http://www.etsi.org>

The present document may be made available in more than one electronic version or in print. In any case of existing or perceived difference in contents between such versions, the reference version is the Portable Document Format (PDF). In case of dispute, the reference shall be the printing on ETSI printers of the PDF version kept on a specific network drive within ETSI Secretariat.

Users of the present document should be aware that the document may be subject to revision or change of status. Information on the current status of this and other ETSI documents is available at

<http://portal.etsi.org/tb/status/status.asp>

If you find errors in the present document, please send your comment to one of the following services:

http://portal.etsi.org/chaicor/ETSI_support.asp

Copyright Notification

No part may be reproduced except as authorized by written permission.
The copyright and the foregoing restriction extend to reproduction in all media.

© European Telecommunications Standards Institute 2004.
All rights reserved.

DECTTM, **PLUGTESTS**TM and **UMTS**TM are Trade Marks of ETSI registered for the benefit of its Members.
TIPHONTM and the **TIPHON logo** are Trade Marks currently being registered by ETSI for the benefit of its Members.
3GPPTM is a Trade Mark of ETSI registered for the benefit of its Members and of the 3GPP Organizational Partners.

Contents

Intellectual Property Rights	5
Foreword.....	5
1 Scope	6
2 References	6
3 Definitions and abbreviations.....	8
3.1 Definitions	8
3.2 Abbreviations	9
4 Overview	10
4.1 Principles for the Analogue presentation of the PSTN.....	10
5 Features and Functionality Summary	11
5.1 Summary of basic features of analogue PSTN terminal equipment	11
5.2 Basic network functions	13
5.3 Enhanced network functions	13
6 Network Tones	17
6.1 General	17
6.2 Basic Network Tones	19
6.2.1 Dial Tone	19
6.2.2 Busy Tone.....	19
6.2.3 Ringing Tone	19
6.2.4 Release Tone.....	19
6.3 Additional Tones	19
6.3.1 Special Dial Tones.....	19
6.3.1.1 Secondary Dial Tone.....	19
6.3.1.2 Special (Intermittent or Stutter) Dial Tone.....	19
6.3.2 Special Information Tone	19
6.3.3 Congestion Tone.....	20
6.3.4 Call Waiting Tone.....	20
7 Ringing.....	20
7.1 General	20
7.2 Basic Ringing Signals	20
7.3 Additional Ringing Signals	20
8 Dialling.....	20
8.1 DTMF Dialling.....	20
8.2 Loop Disconnect (Pulse) Dialling	21
8.3 Other Dialling Systems	21
9 Supplementary Services	21
9.1 General	21
9.2 Signalling mechanisms supporting Supplementary Services	22
9.2.1 General.....	22
9.2.2 DTMF signalling	22
9.2.3 Register Recall (RR).....	23
9.2.4 Additional signalling in the loop state	23
9.2.5 Signalling in the quiescent state.....	23
9.2.6 Distinctive Ringing.....	23
9.2.7 Additional Supervisory Tones from the Network.....	23
9.2.8 Polarity Reversal.....	23
9.2.9 Short Message Service (SMS)	24
10 Presentation of Network Termination Point.....	24
Annex A (informative): Network Tones	25

A.1	Basic Analogue Network Tones.....	25
A.1.1	Dial Tone.....	25
A.1.2	Busy Tone	25
A.1.3	Ringing Tone.....	26
A.1.4	Release Tone	26
A.2	Additional Tones	27
A.2.1	Special Dial Tones.....	27
A.2.1.1	Secondary Dial Tone	27
A.2.1.2	Special (Intermittent or Stutter) Dial Tone	27
A.2.2	Special Information Tone	28
A.2.3	Congestion Tone	28
A.2.4	Call Waiting Tone	28
Annex B (informative): Basic Call Information Flows		29
B.1	Purpose	29
B.2	Explanation of Basic Call Information Flows	29
B.2.1	Detection of loop state by the NTE	29
B.2.2	Handling of supervisory tones by the NTE	29
B.2.3	Detection of Dial Tone by the TE	29
B.2.4	Handling of dialled digits by NTE	29
B.2.5	Detection of call progress tones by the TE.....	29
B.2.6	Generation of Ringing Signal by the NTE	30
B.2.7	Detection of Ringing signal.....	30
B.2.8	Detection of on-hook state by the NTE.....	30
B.2.9	Generation of clearing signal by the NTE.....	30
B.2.10	Detection of clearing signal by the TE	30
B.2.11	No Answer Time Out	30
B.2.12	Handling modem and facsimile transmission by NTE	30
Annex C (informative): Bibliography		34
History		35

Intellectual Property Rights

IPRs essential or potentially essential to the present document may have been declared to ETSI. The information pertaining to these essential IPRs, if any, is publicly available for **ETSI members and non-members**, and can be found in ETSI SR 000 314: "*Intellectual Property Rights (IPRs); Essential, or potentially Essential, IPRs notified to ETSI in respect of ETSI standards*", which is available from the ETSI Secretariat. Latest updates are available on the ETSI Web server (<http://webapp.etsi.org/IPR/home.asp>).

Pursuant to the ETSI IPR Policy, no investigation, including IPR searches, has been carried out by ETSI. No guarantee can be given as to the existence of other IPRs not referenced in ETSI SR 000 314 (or the updates on the ETSI Web server) which are, or may be, or may become, essential to the present document.

Foreword

This ETSI Guide (EG) has been produced by ETSI Technical Committee Access and Terminals (AT), and is now submitted for the ETSI standards Membership Approval Procedure.

The present document is part 2 of a multi-part deliverable. Full details of the entire series can be found in part 1 [33].

1 Scope

The present document describes the functional technical characteristics supported by PSTNs across the wider European market, in order to provide guidance to developers of broadband networks and equipment (e.g. IPCablecom MTA, FWA subscriber units) that support an analogue PSTN terminal.

The present document does not include any Safety or EMC aspects or requirements.

2 References

The following documents contain provisions which, through reference in this text, constitute provisions of the present document.

- References are either specific (identified by date of publication and/or edition number or version number) or non-specific.
- For a specific reference, subsequent revisions do not apply.
- For a non-specific reference, the latest version applies.

Referenced documents which are not found to be publicly available in the expected location might be found at <http://docbox.etsi.org/Reference>.

- [1] ETSI EG 201 121: "A guide to the application of TBR 021".
- [2] ETSI EG 201 188: "Public Switched Telephone Network (PSTN); Network Termination Point (NTP) analogue interface; Specification of physical and electrical characteristics at a 2-wire analogue presented NTP for short to medium length loop applications".
- [3] ETSI ES 201 970: "Access and Terminals (AT); Public Switched Telephone Network (PSTN); Harmonized specification of physical and electrical characteristics at a 2-wire analogue presented Network Termination Point (NTP)".
- [4] ETSI TR 101 182: "Analogue Terminals and Access (ATA); Definitions, abbreviations and symbols".
- [5] ETSI TR 101 183: "Public Switched Telephone Network (PSTN); Analogue ringing signals".
- [6] ETSI TR 101 768: "Public Switched Telephone Network (PSTN); Study on the generation of analogue ringing signals".
- [7] ETSI TR 103 000-1: "Access and Terminals (AT); Analogue Access to Public Telephone Network; Advisory Notes to Standards Harmonizing Terminal Interface; Part 1: List of all Advisory Notes".
- [8] ETSI EN 300 659-1: "Access and Terminals (AT); Analogue access to the Public Switched Telephone Network (PSTN); Subscriber line protocol over the local loop for display (and related) services; Part 1: On-hook data transmission".
- [9] ETSI EN 300 659-2: "Access and Terminals (AT); Analogue access to the Public Switched Telephone Network (PSTN); Subscriber line protocol over the local loop for display (and related) services; Part 2: Off-hook data transmission".
- [10] ETSI EN 300 659-3: "Access and Terminals (AT); Analogue access to the Public Switched Telephone Network (PSTN); Subscriber line protocol over the local loop for display (and related) services; Part 3: Data link message and parameter codings".
- [11] ETSI ES 200 778-1: "Access and Terminals (AT); Analogue access to the Public Switched Telephone Network (PSTN); Protocol over the local loop for display and related services; Terminal Equipment requirements; Part 1: On-hook data transmission".

- [12] ETSI ES 200 778-2: "Access and Terminals (AT); Analogue access to the Public Switched Telephone Network (PSTN); Protocol over the local loop for display and related services; Terminal Equipment requirements; Part 2: Off-hook data transmission".
- [13] ETSI ES 201 187: "2-wire analogue voice band interfaces; Loop Disconnect (LD) dialling specific requirements".
- [14] ETSI ES 201 235-1: "Specification of Dual Tone Multi-Frequency (DTMF) Transmitters and Receivers; Part 1: General".
- [15] ETSI ES 201 235-2: "Access and Terminals (AT); Specification of Dual-Tone Multi-Frequency (DTMF) Transmitters and Receivers; Part 2: Transmitters".
- [16] ETSI ES 201 235-3: "Access and Terminals (AT); Specification of Dual-Tone Multi-Frequency (DTMF) Transmitters and Receivers; Part 3: Receivers".
- [17] ETSI ES 201 235-4: "Access and Terminals (AT); Specification of Dual-Tone Multi-Frequency (DTMF) Transmitters and Receivers; Part 4: Transmitters and Receivers for use in Terminal Equipment for end-to-end signalling".
- [18] ETSI TR 101 959: "Access and Terminals (AT); Ringing without DC for Terminal Equipment (TE), Terminal Support Interfaces (TSI) and Local Exchange Interfaces (LEI)".
- [19] ETSI TBR 021: "Terminal Equipment (TE); Attachment requirements for pan-European approval for connection to the analogue Public Switched Telephone Networks (PSTNs) of TE (excluding TE supporting the voice telephony service) in which network addressing, if provided, is by means of Dual Tone Multi Frequency (DTMF) signalling".
- [20] ITU-T Recommendation G.165: "Echo cancellers".
- [21] ITU-T Recommendation G.168: "Digital network echo cancellers".
- [22] ITU-T Recommendation G.711: "Pulse code modulation (PCM) of voice frequencies".
- [23] ITU-T Recommendation G.723.1: "Speech coders: Dual rate speech coder for multimedia communications transmitting at 5,3 and 6,3 kbit/s".
- [24] ITU-T Recommendation G.729: "Coding of speech at 8 kbit/s using conjugate-structure algebraic-code-excited linear-prediction (CS-ACELP)".
- [25] ITU-T Recommendation T.30: "Procedures for document facsimile transmission in the general switched telephone network".
- [26] ITU-T Recommendation T.38: "Procedures for real-time Group 3 facsimile communication over IP networks".
- [27] IETF RFC 2833: "RTP Payload for DTMF Digits, Telephony Tones and Telephony Signals", H. Schulzrinne, S. Petrack. May 2000.
- [28] ETSI EN 300 001: "Attachments to the Public Switched Telephone Network (PSTN); General technical requirements for equipment connected to an analogue subscriber interface in the PSTN".
- [29] ETSI ES 201 729: "Public Switched Telephone Network (PSTN); 2-wire analogue voice band switched interfaces; Timed break recall (register recall); Specific requirements for terminals".
- [30] ETSI TR 101 041-2: "Human Factors (HF); European harmonization of network generated tones; Part 2: Listing and analysis of European, World and Standardized tones".
- [31] ETSI ES 201 912: "Access and Terminals (AT); Short Message Service (SMS) for PSTN/ISDN; Short Message Communication between a fixed network Short Message Terminal Equipment and a Short Message Service Centre".
- [32] ETSI ETS 300 085: "Integrated Services Digital Network (ISDN); 3,1 kHz telephony teleservice; Attachment requirements for handset terminals (Candidate NET 33)".

- [33] ETSI EG 201 973-1: "Access and Terminals (AT); Public Switched Telephone Network; Support of legacy terminals by Broadband IP networks and equipment; Part 1: General (common part covering both PSTN Analogue and ISDN TE; including definitions for enhanced network functions and supplementary services)".
- [34] ITU-T Recommendation V.18: "Operational and interworking requirements for DCEs operating in the text telephone mode".
- [35] ETSI TBR 038: "Public Switched Telephone Network (PSTN); Attachment requirements for a terminal equipment incorporating an analogue handset function capable of supporting the justified case service when connected to the analogue interface of the PSTN in Europe".
- [36] ETSI EN 301 437: "Terminal Equipment (TE); Attachment requirements for pan-European approval for connection to the analogue Public Switched Telephone Networks (PSTNs) of TE supporting the voice telephony service in which network addressing, if provided, is by means of Dual Tone Multi Frequency (DTMF) signalling".
- [37] IETF RFC 1889: "RTP: A Transport Protocol for Real-Time Applications".

3 Definitions and abbreviations

3.1 Definitions

For the purposes of the present document, the terms and definitions given in TR 101 182 [4] and the following apply:

distinctive ringing: special ringing patterns sent by the network to convey information to the TE about the called number, the calling number or the status of an automatic call request

NOTE: See TR 101 183 [5].

idle line signalling state: state into which the TE when connected to the network, is placed such that it is capable of receiving or sending speechband signalling without entering the loop state

loop state: state where the TE draws sufficient DC current to activate the exchange

NOTE: The Loop state is also known as the on-line state or the off-hook state. See TBR 021 [19].

loop steady state: loop state excluding the transitions from and to quiescent state

NOTE: See TBR 021 [19].

off-hook: See loop state.

on-hook: See quiescent state.

on-line signalling state: on-line state of the TE when the TE is capable of receiving Frequency-Shift Keying (FSK) data, and the normal transmission functions are suspended

quiescent state: state where the TE draws insufficient DC current to activate the exchange

NOTE 1: The Quiescent state is also known as the idle state, off-line state or the on-hook state.

NOTE 2: See TBR 021 [19].

quiescent steady state: quiescent state excluding the transitions from and to quiescent state

Register Recall signal (RR): signal sent from the TE to the telephone network during the communication phase of a call requesting the connection of a dialling detector

release: transition from loop to quiescent state

NOTE: It includes the time slot from the end of loop steady state to the begin of quiescent steady state.

repeat call attempt: further call attempt to the same network address resulting from a failure to establish connection during the previous call attempt

NOTE: See TBR 021 [19].

TE Alerting Signal (TAS): signal transmitted from the network to the TE to initiate a change in state of the TE from idle state to the idle line signalling state

timed break recall: See register recall.

3.2 Abbreviations

For the purposes of the present document, the following abbreviations apply:

3PTY	Three Party Service
ACC	Account Card Calling
ACCS	Automatic Credit Card Service
ACR	Anonymous Call Rejection
AoC	Advice of Charge
AoC-E	Advice of Charge, charging information at the End of the call
CB	Call Back
CCBS	Completion of Calls to Busy Subscriber
CCC	Charge Card Calling
CCNR	Completion of Calls on No Reply
CDIST	Call DISTribution
CF	Call Forwarding
CFB	Call Forwarding Busy
CFNR	Call Forwarding No Reply
CFU	Call Forwarding Unconditional
CIDCW	Calling Identity Delivery on Call Waiting
CL	Call Logging
CLI	Calling Line Identification
CLIP	Calling Line Identification Presentation
CLIR	Calling Line Identification Restriction
CNAM	Calling NAME delivery
CND	Calling Number Delivery
CNIP	Calling Name Identification Presentation
CNIR	Calling Name Identification Restriction
COLP	COnnected Line identification Presentation
COLR	COnnected Line identification Restriction
CONF	CONFerence call, add on
CRED	CREDit card calling
CT	Call Transfer
CUG	Closed User Group
CVD	Call Volume Distribution
CW	Call Waiting
DC	Delivery Confirmation
DC	Direct Current
DDI	Direct Dialling In
DR	Distinctive Ringing
DRCN	Distinctive Ringing Called Number dependent
DRCW	Distinctive Ringing/Call Waiting
DT	Dial Tone
DTMF	Dual Tone Modulation Frequency
DTMF	Dual Tone Multi-Frequency
ECT	Explicit Call Transfer
EMEA	European Technology Services
EP ATA	ETSI Project Analogue Terminals and Access
FSK	Frequency Shift Keying
FWA	Fixed Wireless Access
GD	General Deactivation
HOLD	call HOLD

ICB	Incoming Call Barring
IFS	International Freephone Service
IP	Internet Protocol
LH	Line Hunting
MBG	Multi-location Business Group
MCID	Malicious Call IDentification
MF	Multi-Frequency (see DTMF)
MLPP	MultiLevel Precedence and Pre-emption
MMC	Meet-Me Conference
MR	Message Relay
MTA	Media Terminal Adapter
MWI	Message Waiting Indication
NCT	Normal Call Transfer
NGN	Next Generation Network
NTE	Network Terminating Equipment
NTP	Network Termination Point
OCB	Outgoing Call Barring
PABX	Private Automatic Branch eXchange
PAD	Packet Assembler/Disassembler
PC	Permanent Circuit
PRI	PRIority
PS	Priority Selection
PSN	Permanent Subscriber Number
PSTN	Public Switched Telephone Network
PVC	Permanent Virtual Circuit
QoS	Quality of Service
RCSS	Remote Control of Supplementary Services
RLC	Repeat Last Call
RLR	Receive Loudness Rating
RR	Register Recall
RTP	Real-Time Protocol

NOTE: See RFC 1889 [37].

RTP	Realtime Transport Protocol
SA	Selective Accounting
SCF	Selective Call Forwarding
SCT	Single step Call Transfer
SLE	Screening List Edit
SMS	Short Message Service
SPNP	Support of Private Numbering Plan
TE	Terminal Equipment
TH	Trunk Hunting
TP	Terminal Portability
TTE	Telecommunications Terminal Equipment
UAN	Universal Access Number
UDR	User Defined Routing
UUS	User-User Signalling
VB	Voice Box
VCC	Virtual Card Calling
VOT	teleVOTing

4 Overview

4.1 Principles for the Analogue presentation of the PSTN

Although the presentation of national public switched telephone networks has evolved over an extended period, much effort within ETSI TC Access and Terminals and its predecessors (EP ATA and STC TE4 and STC TE5) has brought about a massive reduction in the presentation of technical differences between the networks.

These characteristics were largely harmonized by TBR 021 [19], EN 301 437 [36] and TBR 038 [35], but some enhancements and additional network particularities are listed in EG 201 121 [1] and later in the TR 103 000-1 [7] and corresponding subparts.

TBR 021 [19] and ES 201 970 [3] consider the harmonization of basic electrical and mechanical characteristics; e.g. a harmonized plug and socket for these Telecommunications Terminal Equipment (TTE), the recommended presentation is given in clause 10 of the present document.

NOTE: Draft ES 203 021 is presently transferring and updating the technical content of TBR 021 [19] to reflect the market and global realities.

The following are the core features/functions that are used as the basis for the present 1st edition of the present document:

- Seize;
- Hold;
- Release;
- Dial;
- Call progress indication;
- Network tones;
- Ring;
- Transmit and receive information for voice and other voice band services.

The following features/functions are identified, but not completely studied in the present document:

- Register Recall;
- Meter Pulses;
- Advice of Charge (AoC);
- Calling Line Identification (CLI) features;
- Other Supplementary Services (e.g. SMS), as relevant.

5 Features and Functionality Summary

5.1 Summary of basic features of analogue PSTN terminal equipment

Table 1 lists the basic features of analogue TE and how they are implemented.

Table 1: Basic features supported by analogue PSTN terminal equipment

	Feature Name	Implementation by TE	Related standards	Comments
Basic Features	Seize	Off-hook d.c. conditions established	TBR 021 [19]	
	Hold	d.c. conditions established	TBR 021 [19]	
	Release	On-hook d.c. conditions established	TBR 021 [19]	
	Dial	DTMF typically supported.	TBR 021 [19], ES 201 235-1 [14], ES 201 187 [13]	Older TE may also only support Loop Disconnect (pulse) dialling.
	Ringing	Ringing detector	TBR 021 [19], TR 101 183 [5], TR 101 959 [18], TR 101 768 [6]	
	Polarity Reversal	Intolerance to reversal of polarity	EN 300 659 EG 201 188 [2]	Polarity reversal can be used to indicate called party answer and end-of-call. Polarity reversal can also be used for other signalling purposes.
	Dial Tone (DT)	Optionally detected by autocalling equipment.	TBR 021 [19]	Within a handset/cordless or hands free telephone TE this is passed to the ear-piece/speaker.
	Second DT	Optionally detected by autocalling equipment.	TBR 021 [19]	Within a handset/cordless or hands free telephone TE this is passed to the ear-piece/speaker.
	Special DT	Optionally detected by autocalling equipment.	TBR 021 [19]	Within a handset/cordless or hands free telephone TE this is passed to the ear-piece/speaker.
	Busy Tone	Should be detected by autocalling equipment.		Within a handset/cordless or hands free telephone TE this is passed to the ear-piece/speaker.
	Ringing Tone	Should be detected by autocalling equipment.		Within a handset/cordless or hands free telephone TE this is passed to the ear-piece/speaker.
	Register Recall (RR)	Timed break of off-hook d.c. conditions	ES 201 729 [29]	
	Auto-Calling	Seize and dial functions not under direct user control	TBR 021 [19]	
	Auto-Answer	Uses ringing detector to detect an incoming call and automatically answer	TBR 021 [19], TR 101 183 [5], TR 101 959 [18]	A variety of functions can be provided in the loop state by an auto-answering device, including playing a recorded announcement, recording a message from a caller, a variety on interactive features based on receipt of DTMF signals, or data/faxes may be sent or received
	Auto-Clearing	Detection of polarity reversal, k-break, or loss of data carrier signal, detection of a period of time with low speechband signal levels, or clear-down after a fixed time in the loop state or after completing the sending of data (e.g. completion of a fax)	TBR 021 [19]	Fax/modem equipment generally automatically clears on loss of carrier, and therefore does not require special signalling from the network to detect a far-end clear.
	Voice transmission	Basic voice transmission	TBR 038 [35]	For a simple handset.

5.2 Basic network functions

Table 2 lists the essential network facilities/functions and identifies how they are supported by analogue NTE.

Table 2: Basic Network functions supported by analogue PSTN NTE

	Function Name	Implementation by NTE	Related standards	Comments	
Basic Features	Seize	Detection of loop current.	ES 201 970 [3]		
	Hold	Detection of loop current.	ES 201 970 [3]		
	Release	Detection of loss of loop current.	ES 201 970 [3]		
	Dial	Detection of loop-disconnect and/or DTMF signals.	ES 201 235-3 [16] ES 201 970 [3] ES 201 187 [13]		
	Ringing	Generation and cadence of ringing voltage.	TR 101 183 [5]	In order to ensure compatibility with the installed base of terminals in certain European States it may be necessary to use polarity reversals to indicate start and end of ringing signal. In these cases, compatibility should be adequately ensured if the normal DC polarity is reversed when the first ringing voltage is applied. The polarity should revert to the normal polarity when the line is seized or cleared.	
	Call Progress	Dial Tone (DT)	Generated either within the NTE or within the Call Control function.	ES 201 970 [3]	See call information flow examples in annex B and clause B.2.2.
		Second DT	Generated either within the NTE or within the Call Control function.	ES 201 970 [3]	See call information flow examples in annex B and clause B.2.2.
		Busy Tone	Generated either within the NTE or within the Call Control function.	ES 201 970 [3]	See call information flow examples in annex B and clause B.2.2.
		Ringing Tone	Generated either within the NTE or within the Call Control function.	ES 201 970 [3]	See call information flow examples in annex B and clause B.2.2.
	Additional Supervisory Tones	Release Tone	Generated either within the NTE or within the Call Control function.	ES 201 970 [3]	See call information flow examples in annex B and clause B.2.2.
		Congestion Tone	Generated either within the NTE or within the Call Control function.	ES 201 970 [3]	See call information flow examples in annex B and clause B.2.2.
		Special Information Tone	Generated either within the NTE or within the Call Control function.	ES 201 970 [3]	This is largely not harmonized throughout Europe.
		Call Waiting Tone	Generated either within the NTE or within the Call Control function.	ES 201 970 [3]	Data modems and facsimile TE generally require the ability to temporarily turn off this network feature prior to communication. As the transmission quality is degraded and interrupted as a result of Call Waiting Tone being provided by the network.

5.3 Enhanced network functions

In some cases, Enhanced network functions (e.g. supplementary services and SMS) will require a variety of additional signalling arrangements beyond those necessary for a basic call.

Table 3 describes possible technical solutions for the implementation of a variety of supplementary services and other enhanced network functions over an analogue 2-wire interface.

Currently the majority of the service descriptions produced that are available within ETSI relate to ISDN, however, these may be of use when defining the support of enhanced network functions by Analogue TE within non-ISDN broadband networks.

Table 3: Enhanced Network functions supported by analogue PSTN terminal equipment

		Service Type and Name	Possible implementation by TE	Comments and reference standards
Enhanced Features	Abbrev. Address Services	AA	For further study.	
		FDC	For further study.	
		RLC	For further study.	
	Address Information Services	APC	For further study.	
		DDI	For further study.	
		DR	No impact on ring detect circuit of a simple telephone.	Unless the network parameters for a specific ring pattern have been pre-defined, such that TE with an automatic answer function can be designed to detect the pattern, certain TE may not be able to use this facility.
		DRCN	No impact on ring detect circuit of a simple telephone.	Unless the network parameters for a specific ring pattern have been pre-defined, such that TE with an automatic answer function can be designed to detect the pattern, certain TE may not be able to use this facility.
		DRCW	No impact on ring detect circuit of a simple telephone.	Unless the network parameters for a specific ring pattern have been pre-defined, such that TE with an automatic answer function can be designed to detect the pattern, certain TE may not be able to use this facility.
		MSN	Distinctive ringing cadence and/or in-band or out-band signalling from the network to the terminal in the on-hook signalling state.	
		SUB	Distinctive ringing cadence and/or in-band or out-band signalling from the network to the terminal in the on-hook signalling state.	
	Advice of Charge Services	AoC	In-band signalling from the network to the terminal in the off-hook and/or on-hook signalling state.	Refer to ES 300 778-1 [11] and ES 300 778-2 [12]
		AoC-S	For further study.	Defined with EN 300 659-3 [10]
		AoC-D	For further study.	Defined with EN 300 659-3 [10]
		AoC-E	The Advice of Charge: Charging information at the End of the call (AoC-E) supplementary service enables a user to receive information on the recorded charges for a call when the call is terminated.	Defined with EN 300 659-3 [10]
		AoC-R	For further study.	
	Call Booking Services	Alarm Call	For further study.	
		Booked Call	For further study.	
		Diary Service	For further study.	
	Call Barring Services	CUG	No user-network signalling required.	
		ICB	For further study.	
		OCB-F	No user-network signalling required.	
		OCB-UC	DTMF signalling.	Requires that changes to barring are validated by means of password.
		SS	For further study.	
		IIFC	For further study.	
		ACR	For further study.	
		SCA	For further study.	
		SCR	For further study.	
ADS	For further study.			

Service Type and Name		Possible implementation by TE	Comments and reference standards	
Enhanced Features	Call Completion Services	CW	To detect a waiting call: 1) Supervisory tones or voice announcements; or 2) Out-of-band signalling. To retrieve a waiting call, timed-break recall, possibly with DTMF signalling.	Option 2 requires special terminal able to recognize the signalling.
		CCBS	Distinctive ringing cadence and DTMF signalling.	
		QS	For further study.	
		CCNR	For further study.	
		Called Line Free Indication	For further study.	
		Call Return	For further study.	
	Call Reg. Services	CB	For further study.	
		Date and Time Call Record	For further study.	
		CL	For further study.	
		MCID	No implementation.	
	Changed Charging Services	BCLID	For further study.	
		FPH	For further study.	
REV-S		For further study.		
REV-U		For further study.		
Transfer of Charge		For further study.		
Wide Area Service		For further study.		
Split Charging		For further study.		
Premium Rate		For further study.		
International [Premium Rate] Service		For further study.		
IFS		No user-network signalling required.		
Diversion Services	Home Country Direct	For further study.		
	CFU	DTMF signalling required to activate or deactivate.		
	CB	For further study.		
	CD	Outband signalling from the terminal in on-hook signalling state.		
	SCF	For further study.		
	CF	DTMF signalling required to activate or deactivate.		
	CFB	DTMF signalling required to activate or deactivate.		
	CFB-S	DTMF signalling required to activate or deactivate.		
	CFNR	DTMF signalling required to activate or deactivate.		
	CFNR-S	DTMF signalling required to activate or deactivate.		
	CFU-S	DTMF signalling required to activate or deactivate.		
	SCF Busy	DTMF signalling required to activate or deactivate.		
SCF Reply	DTMF signalling required to activate or deactivate.			

Service Type and Name		Possible implementation by TE	Comments and reference standards
Enhanced Features	Help Services	Fault Reporting	For further study.
		GD	For further study.
		Operator Access to and Control of Supplementary Services	For further study.
		RCSS	For further study.
		Time Dependent Control of Supplementary Services	For further study.
		SLE	For further study.
	Information Transfer Services	DC	For further study.
		PDC	For further study.
		UUS	Two-way outband signalling in the online state.
		VB	For further study.
		MWI	In-band or out-band signalling from the network to the terminal in the on-hook state, or line polarity reversal.
		SMS Text [S21 and S22]	For further study.
	Multiline Services	Centrex	For further study.
		LH	For further study.
		TH	For further study.
		SPNP	For further study.
		MBG	For further study.
	Multiparty Calls	HOLD	Timed-break recall, possibly with DTMF signalling.
		3PTY	Timed-break recall with DTMF signalling.
		CT	For further study.
		NCT	For further study.
		ECT	Timed-break recall with DTMF signalling.
		SCT	For further study.
		CONF	Timed-break recall with DTMF signalling.
		MMC	For further study.
		Lecture Call	For further study.
		PCC	For further study.
	Booked Add-On Conference	For further study.	
Identification Services	CIDCW	For further study.	
	CLIP	For further study.	EN 300 659-1 [8], EN 300 659-2 [9], EN 300 659-3 [10].
	CLIR	For further study.	
	CNAM	For further study.	
	CND	For further study.	
	CNIP	For further study.	
	CNIR	For further study.	
	COLP	For further study.	
COLR	For further study.		
Numbering Services	Out of Area Line	For further study.	
	PSN	For further study.	
	UAN	For further study.	
	CDIST	For further study.	
	CVD	For further study.	
	UDR	For further study.	
	Temporary Location of Outgoing Calls	For further study.	
	PC	For further study.	
PVC	For further study.		

Service Type and Name		Possible implementation by TE	Comments and reference standards
Enhanced Features	Payment Charging Services	CRED	For further study.
		Payphone	For further study.
		ACCS	For further study.
		ACC	For further study.
		Automatic Transfer Call Charge	For further study.
		SA	For further study.
		CCC	For further study.
		VCC	For further study.
	Priority Service	PRI	For further study.
		PS	For further study.
		MLPP	For further study.
	Opinion Collecting Services	VOT	For further study.
		Teledialogue	For further study.
		Mass Calling	For further study.
	Miscellaneous Services	Alarm (Warning)	For further study.
		Changing of Service during an Established Call	For further study.
		Expediting of a call in progress	For further study.
		Interception of Calls	Not Implemented.
		National Selection and Indication of Throughput Class	Not Implemented.
		TP	Specific to ISDN basic rate, not required for analogue.
User selection of PAD Parameter Settings		For further study.	Unlikely to be required, since most data services will normally be carried through the broadband connection.
CDO		For further study.	
IM		For further study.	
Pick-up facility		For further study.	
MR		For further study.	

NOTE: Future revisions of the present document may enhance table 3 to show complete examples of impact and implementation within analogue TE of such enhanced features (supplementary services).

6 Network Tones

6.1 General

When a user makes a telephone call, tones are a necessary part of the interaction between the network and the user in the process of setting up the call.

The user of a simple telephone terminal only requires that the tones be presented at a suitable time and at a suitable level. This generally implies that when going off hook, a normal transmission path should be established between the telephone line and the receive output transducer, whether it is an earphone or a loudspeaker. The network designer shall ensure that the tones are applied at a level compatible with the terminal Receive Loudness Rating (RLR) suitable for speech transmission.

One additional factor to be considered is the presence of any receive volume control or mute switch. It is a common requirement of telephone specifications that at the minimum setting of the volume control it should still be possible to hear the network tones. This has been specified in ETS 300 085 [32] by requiring that "with the volume control set to the minimum position, the RLR shall not be greater than (quieter than) 18 dB" (it may be noted that, due to the history of their derivation, high positive values of loudness rating are indicative of low sensitivity or quietness, and low or negative values indicative of high sensitivity).

It is recommended that any receive mute condition that has a latching arrangement should be arranged such that the mute is removed after hanging up so that normal transmission is available when going off hook again, in case a user in an emergency situation is misled into the belief that the telephone or its associated line is defective or out of use.

Terminals that offer automatic calling have additional special requirements. The user of such a terminal, whether it is a telephone, PABX, fax or modem requires the call to be set up as rapidly as possible. Similarly, the network designer requires the minimum possible unpaid network occupancy.

To achieve the shortest possible call set up time a terminal needs to detect dial tone before initiating dialling. If dial tone detection is not implemented, dialling too soon may generate either incomplete or incorrect numbers, or excessive delays may be caused by waiting for a sufficient period (typically 4 s) to give a reasonable assurance that dial tone is present before dialling. Such a wait is not compatible with the recommendation by Gallaway that system activation or requests for a complex service should achieve response times of 3 to 5 s.

Where dial tone is presented to the user in the normal manner so that the decision to commence automatic dialling can be taken by the user, such a dial tone detector is not necessary.

In order to ensure the minimum possible unpaid network occupancy, a fully automatic terminal is often required to detect call progress tones and clear down on receipt of tones indicating an ineffective call. It is usual for modems to be able to detect and discriminate between dial tone, busy tone, ring tone, answer tone, carrier and speech. Whether the detection facility is used or not, and the timings for which tones are awaited are usually software controllable.

It is common for modems and fax machines not to detect any progress tones or other signals, but to clear down if the normal connection protocols that follow call answer are not received from the called terminal within a predetermined time period.

Tones that occur during the Talk phase create problems for modems or fax machines in that they interfere with the received signal. It is thus necessary to make arrangements for such tones to be able to be suppressed, preferably on a per call basis.

Dial, ringing, busy and release tones as specified in ES 201 970 [3], clause 13 should only be used when they will be associated to:

- DIAL (invitation for the user to dial the number of the called party);
- RINGING (indication that the called party is being called);
- BUSY (indication that the called party is busy); and
- RELEASE (indication that the network released the connection) functions.

NOTE 1: The aforementioned harmonized tones are not necessarily the ones supplied by all the existing networks, they were nevertheless identified as the ones covering more appropriately the largest majority of the market situation.

NOTE 2 ES 201 970 [3], clause 13 makes also useful references to other existing network tones. It is important to consider that the user has a limited capability of identifying different tones.

The intention of this clause is mainly to require that:

- 1) "network fundamental tones" should not be used for other purposes; and
- 2) a secondary requirement could be to standardize some tones like the special information tone, which would probably be the most useful to an announcement server application. There might be advantages and risks to harmonize the special information tone, slightly different applications for machine-machine dialogs, may need small variations in the tones used.

The following clauses identify the harmonized parameters for basic and additional network tones. Although it is the intension of the present document to also identify the variances that have been implemented within analogue TE, in order for them to operate correctly throughout the geographical study area (see table 1 of EG 201 973-1 [33]), this work may be covered in a later study phase.

6.2 Basic Network Tones

6.2.1 Dial Tone

Taking into consideration the harmonization of analogue TE throughout the European Union based upon TBR 021 [19], the recommended nominal cadences and frequency values for Dial Tone are those specified in ES 201 970 [3] and are shown in table A.1 under group A.

6.2.2 Busy Tone

Taking into consideration the harmonization of analogue TE throughout the European Union based upon TBR 021 [19], the recommended values for Busy Tone are those specified in ES 201 970 [3] and are shown in table A.2 under group A.

6.2.3 Ringing Tone

Taking into consideration the harmonization of analogue TE throughout the European Union based upon TBR 021 [19], the recommended values for Ringing Tone are those specified in ES 201 970 [3] and are shown in table A.3 under group A.

6.2.4 Release Tone

Taking into consideration the harmonization of analogue TE throughout the European Union based upon TBR 021 [19], the recommended values for Release Tone are those specified in ES 201 970 [3] and are shown in table A.4 under group A.

6.3 Additional Tones

Call Progress Indication is an expression preferred in the ISDN environment and is covered in this clause on additional Network Tones.

6.3.1 Special Dial Tones

6.3.1.1 Secondary Dial Tone

Taking into consideration the harmonization of analogue TE throughout the European Union based upon TBR 021 [19], the recommended values for Secondary Dial Tone are those specified in ES 201 970 [3] and are shown in table A.5 under group A.

6.3.1.2 Special (Intermittent or Stutter) Dial Tone

Taking into consideration the harmonization of analogue TE throughout the European Union based upon TBR 021 [19], the recommended values for Special Dial Tone are those specified in ES 201 970 [3] and are shown in table A.6 under group A.

6.3.2 Special Information Tone

Taking into consideration the harmonization of analogue TE throughout the European Union based upon TBR 021 [19], the recommended values for Special Information Tone are those specified in ES 201 970 [3] and are shown in table A.7 under group A.

6.3.3 Congestion Tone

Taking into consideration the harmonization of analogue TE throughout the European Union based upon TBR 021 [19], the recommended values for Congestion Tone are those specified in ES 201 970 [3] and are shown in table A.8 under group A.

6.3.4 Call Waiting Tone

Taking into consideration the harmonization of analogue TE throughout the European Union based upon TBR 021 [19], the recommended values for Call Waiting Tone are those specified in ES 201 970 [3] and are shown in table A.9 under group A.

7 Ringing

7.1 General

Reference should generally be made to TR 101 183 [5], TR 101 768 [6], TR 101 959 [18] and ES 201 970 [3]. The intention of this clause is simply to identify the variables related to the parameters that would need to be supported within a NGN.

7.2 Basic Ringing Signals

Guidance on the generation of ringing signals may be found in TR 101 768 [6]. Guidance on ringing without DC may be found in TR 101 959 [18]. Electrical characteristics of the ringing drive capability (i.e. ring frequency and voltage) and the nominal cadence of a basic ringing signal are given in ES 201 970 [3].

Refer to TR 101 183 [5] for more details of the cadences used in different countries.

7.3 Additional Ringing Signals

Additional ringing signals vary from the basic ringing signal in the cadence given, in order to provide distinctive ringing. Again, the cadence used varies between countries. Refer to TR 101 183 [5] and TR 101 959 [18] for more details.

It may be appropriate to ensure that automatic answering equipment can be programmed to distinguish between basic ringing and distinctive ringing, so that it does not automatically answer a distinctive ring used for a ringback (i.e. indicating that a busy number previously called is now free.)

8 Dialling

8.1 DTMF Dialling

DTMF dialling is the preferred method of address signalling. ES 201 235-1 [14] specifies the basic characteristics for DTMF signalling, such as the assignment of codes to frequency pairs. ES 201 235-2 [15] specifies the characteristics of DTMF transmitters in the terminal equipment. ES 201 235-3 [16] specifies the characteristics of the DTMF receiver in the network equipment, used for detecting the address signalling sent by the user.

Whilst the majority of legacy TE available within European countries may have been designed to meet the requirements as specified in TBR 021 [19], the DTMF dialling requirements of central and east European countries are different; both are given as examples below:

- TBR 021 [19] specifies that the level of any tone in the DTMF high frequency group shall be $-9,0$ dBV $+2,0/-2,5$ dB and the level of any tone in the low frequency group shall be $-11,0$ dBV $+2,5/-2,0$ dB when the TE interface is terminated with the complex reference impedance. TBR 021 [19] also specifies that during sending of any DTMF frequency combination, the level of the tone in the high frequency group shall be 1 dB to 4 dB higher than the level of the tone in the low frequency.
- Throughout many central and eastern European countries the level of any tone in the DTMF high frequency group is specified as $-6,0$ dBm $\pm 2,0$ dBm and the level of any tone in the low frequency group as $-8,0$ dBm $\pm 2,0$ dBm. Generally it is required that the sending level of any DTMF combination in the high frequency group shall be 1 dB to 3 dB higher than the level of the tone in the low frequency. When the TE interface is terminated with a 600Ω reference impedance.

NOTE 1: In the development of TBR 021 [19] the values specified in the second bullet were considered and were intended to ensure backwards compatibility as far as is possible.

Broadband terminals should therefore have sufficient tolerance to correctly recognize DTMF dialled digits from a wide range of legacy analogue terminals, for this purpose the values as specified in clause 11 of ES 201 970 [3] should be used.

NOTE 2: DTMF signalling is also widely used for end-to-end signalling through the network (e.g. issuing commands to voice mail systems). Refer to clause 9.2.2 for further information.

8.2 Loop Disconnect (Pulse) Dialling

Loop Disconnect dialling is an older signalling system still in widespread use. ES 201 187 [13] specifies the characteristics of terminal equipment that implements Loop Disconnect dialling.

DTMF is generally preferred to Loop Disconnect, both because the address information is sent more quickly, and also because DTMF can also be used for end-to-end signalling.

8.3 Other Dialling Systems

While analogue interfaces have been developed in the past that use a variety of other signalling systems for communicating address information, none is now in widespread use on ordinary subscriber interfaces to the PSTN.

9 Supplementary Services

9.1 General

A variety of signalling is required to support calling features such as:

- Advice of Charge;
- Call Back;
- Call Waiting;
- Cancel Call Waiting;
- Call Forwarding (no-answer, busy, variable);
- Three-way Calling (3PTY);
- Voice mail Message Waiting Indicator;

- Calling Number Delivery;
- Calling Name Delivery;
- Calling Identity Delivery On Call Waiting;
- Calling Identity Delivery Blocking;
- Anonymous Call Rejection;
- Automatic Callback;
- Automatic Recall;
- Distinctive Ringing;
- Call Waiting;
- Customer Originated Trace.

Annex B of EG 201 973-1 [33] lists the relevant supplementary service definitions.

9.2 Signalling mechanisms supporting Supplementary Services

9.2.1 General

There are several signalling mechanisms that can be used to support supplementary services, many of these mechanisms have standardized codes associated. Different mechanisms are needed depending on the nature of the service provided. These include the following:

- DTMF signalling in the active state of the call (end-to-end).
- Register recall.
- Additional signalling in the loop state.
- Signalling in the quiescent state.
- Distinctive ringing.
- Additional supervisory tones from the network.
- Polarity reversal in the on-hook or off-hook state.

9.2.2 DTMF signalling

DTMF signalling can be used in the loop state to activate or deactivate supplementary services, such as activating Call Forward and specifying the forwarded number. It can also be used in association with Register Recall during an active call, to invoke a conference connection. Or simply to issue commands to voice mail systems, ES 201 235-4 [17] specifies the characteristics of DTMF transmitters and receivers in remote equipment using DTMF for this purpose.

The same DTMF transmitters and receivers can be used for supplementary services as for address signalling. See clause 8.1 for more details.

However, a broadband network may employ the use of low bit-rate audio codecs to encode audio channels - this encoding process destroys in-band signalling information which is carried using the least-significant bit ("robbed bit signalling") and may also interfere with in-band signalling tones, such as the MF digit tones and modem tones (ITU-T Recommendation V.18 [34]) as supported by Text Telephones. Thus, the gateway needs to remove the in-band signalling information from the bit stream. As an example a broadband network may use an "RTP trunk" application, RTP is used to replace a normal circuit-switched trunk between two nodes. In this case, each end of the RTP trunk encodes audio channels into the appropriate encoding, such as ITU-T Recommendations G.723.1 [23] or G.729 [24].

It is therefore highly recommended that such applications use the payload format(s) as described in RFC 2833 [27] to support end-to-end DTMF/MF signalling.

9.2.3 Register Recall (RR)

Register Recall (also known as timed-break recall) occurs when the TE makes a break in the loop current of a duration generally in the range 90 ms to 120 ms. ES 201 729 [29] specifies the characteristics of the Register Recall signal.

Register recall is used to alert the network equipment that a supplementary service is about to be requested for the call currently in progress, such as call hold or conference call. The register recall is usually followed by DTMF signalling, which communicates the details of the requested service

9.2.4 Additional signalling in the loop state

Additional signalling in the loop state is sometimes necessary to provide additional services.

Out-of-band signalling is sometimes necessary to communicate information during a call without disrupting the voice path. The most common example is metering, where meter pulses using 12 kHz or 16 kHz signals are used. See ES 201 970 [3], clause 14.3.

In-band signalling, as described in EN 300 659-2 [9] and ES 200 778-2 [12], is used for providing PSTN display services such as call waiting indication.

9.2.5 Signalling in the quiescent state

Signalling in the quiescent state (also known as on-hook signalling) is used to transmit information not associated with a call (e.g. message services or message waiting indication) or information associated with the call, but prior to the call being answered (e.g. CLIP).

EN 300 659-1 [8] and ES 200 778-1 [11] specify the characteristics of on-hook data transmission.

9.2.6 Distinctive Ringing

Distinctive Ringing can be used to indicate that a supplementary service is associated with an incoming call. See clause 7.3 for more details. Refer also to TR 101 183 [5] for a list of the variations.

9.2.7 Additional Supervisory Tones from the Network

Additional supervisory tones can be generated by the network for a variety of purposes associated with supplementary services.

Supervisory tones can either be sent during an active call (such as Call Waiting tone) to indicate the availability of a supplementary service, or as an acknowledgement of a command from the terminal equipment. In the latter case, the tone may be followed by a recorded voice announcement.

9.2.8 Polarity Reversal

Simple signalling conditions can be indicated by the network in the form of polarity reversal on the loop state or quiescent state. For instance, Message Waiting Indication could be implemented by a polarity reversal in the quiescent state.

9.2.9 Short Message Service (SMS)

The ETSI SMS assumes that both the sending and receiving terminal equipment (TE) have appropriate capabilities to send, receive, store, display and delete short messages.

The SMS can be realized in two ways:

- either a **User Based Solution (UBS)** (refer to ES 201 912 [31]) using the basic call procedures; or
- a **Network Based Solution (NBS)**.

The UBS service is provided as part of a function within the end-user equipment, which does not require any specific short message transfer function inside the public network.

Two protocols are available and are currently being developed:

- **Protocol UBS 1:** this protocol is fully compliant with the GSM SMS service;
- **Protocol UBS 2:** this protocol is specifically focuses on the residential fixed network environment.

10 Presentation of Network Termination Point

The recommended harmonized arrangement for the presentation of the NTP to analogue TE is as a socket, as specified in ES 201 970 [3], clause 5 option 2 (TBR 021 [19]). A variety of national presentations can be found in EN 300 001 [28].

Annex A (informative): Network Tones

This annex studies and groups the various network tones supported by analogue TE, which have been designed to comply with both harmonized standards and historical national standards. The purpose of this annex is to highlight the reality and possible incidence of such TE in use, which broadband equipment may be designed to support throughout the geographical study area (see EG 201 973-1, table 1 [33]).

The information provided in this clause is non-exhaustive and a complete list of countries variables is for further study.

A.1 Basic Analogue Network Tones

A.1.1 Dial Tone

Table A.1: Supervisory signal Dial Tone - Nominal cadences and frequencies

Country/Region	Cadence	Frequency
Group A (Harmonized)	Continuous	425 Hz
Group B	0,33 s on, 0,33 s off, 0,66 s on, 0,66 s off	425 Hz \pm 20 Hz
Group C	Continuous	425 Hz \pm 25 Hz
Group D	0,7 s on, 0,8 s off, 0,2 s on, 0,3 s off	425 Hz
Bulgaria (older variance 1)	0,25 s on, 0,3 s off, 0,7 s on, 0,8 s off	425 Hz
Bulgaria (older variance 2)	0,25 s on, 0,75 s off, 0,75 s on, 1 s off	425 Hz
Croatia (older variance)	0,2 s on, 0,3 s off, 0,7 s on, 0,8 s off	425 Hz
Hungary	Continuous	425 Hz - 8,2 % + 9,4 %
Italy (older variance)	0,2 s on, 0,2 s off, 0,6 s on, 1 s off	425 Hz
Turkey (older variance)	Continuous	450 Hz

Unless otherwise specified the tolerances for cadences are $\pm 10\%$ and for frequencies $\pm 1,5\%$.

Group A: Albania, Austria, Belgium, Bulgaria*, Croatia*, Cyprus, Denmark, Finland, France, Germany, Greece, Iceland, Ireland, Italy*, Luxembourg, Netherlands, Norway, Poland*, Portugal, Romania*, Slovenia*, Spain, Sweden, Switzerland, Turkey* and United Kingdom.

Group B: Czech Republic and Slovak Republic.

Group C: Belarus, Estonia, Latvia, Lithuania, Russian Federation and Turkmenistan.

Group D: Slovenia (older variance), Yugoslavia.

Sources: ES 201 970 [3], Independent studies by European Technology Services (EMEA), TR 101 041-2 [30] and GOST 26557-85 and FMS č.j. 6123/92.

NOTE: * Some variances exist in the provision of the supervisory tone and hence older analogue TE may only recognize the national (regional) variance.

A.1.2 Busy Tone

Table A.2: Supervisory signal Busy Tone - Nominal cadences and frequencies

Country/Region	Cadence	Frequency
Group A (Harmonized)	0,5 s on, 0,5 s off	425 Hz
Group B	0,33 s on, 0,33 s off	425 Hz \pm 20 Hz
Hungary	0,3 s on, 0,3 s off	390 Hz to 465 Hz

Unless otherwise specified the tolerances for cadences are $\pm 10\%$ and for frequencies $\pm 1,5\%$.

Group A: Austria, Belgium, Bulgaria, Croatia, Cyprus, Denmark, Finland, France, Germany, Greece, Iceland, Ireland, Italy, Luxembourg, Netherlands, Norway, Poland, Portugal, Slovenia, Spain, Sweden, Switzerland, United Kingdom and Yugoslavia.

Group B: Czech Republic, Slovak Republic.

Sources: ES 201 970 [3], Independent studies by European Technology Services (EMEA), FMS č.j. 6123/92 and TR 101 041-2 [30].

NOTE: * Some variances exist in the provision of the supervisory tone and hence older analogue TE may only recognize the national (regional) variance.

A.1.3 Ringing Tone

Table A.3: Supervisory signal Ringing Tone - Nominal cadences and frequencies

Country/Region	Cadence		Frequency
Group A (Harmonized)	1 s on,	4 s off	425 Hz
Group B	1 s on,	4 s off	425 Hz \pm 20 Hz
Group C	0,8 on,	3,2 s off	425 Hz
Czech Republic PABX variant (1)	0,3 s on,	0,3 s off	425 Hz \pm 20 Hz
PABX variant (2)	0,3 s on, 0,3 s off,	0,3 s on, 4 s off	425 Hz \pm 20 Hz
Hungary	1,25 s on,	3,75 s off	16,66 Hz or 25 Hz or 390 Hz to 465 Hz

Unless otherwise specified the tolerances for cadences are $\pm 10\%$ and for frequencies $\pm 1,5\%$.

Group A: Albania, Austria, Belgium, Bulgaria*, Croatia, Denmark, Estonia, Finland, France, Germany, Greece, Iceland, Ireland, Italy, Luxembourg, Netherlands, Norway, Portugal, Poland, Russian Federation*, Slovak Republic, Slovenia*, Spain, Sweden, Switzerland, United Kingdom and Yugoslavia*.

Group B: Czech Republic*.

Group C: Lithuania and Russian Federation (older variance).

Sources: ES 201 970 [3], Independent studies by European Technology Services (EMEA), FMS č.j. 6123/92 and TR 101 041-2 [30].

NOTE: * Some variances exist in the provision of the supervisory tone and hence older analogue TE may only recognize the national (regional) variance.

A.1.4 Release Tone

Table A.4: Supervisory signal Release Tone - Nominal cadences and frequencies

Country/Region	Cadence		Frequency
Group A (Harmonized)	0,25 s on,	0,25 s off	425 Hz
Group B	Not supported		N/A

Unless otherwise specified the tolerances for cadences are $\pm 10\%$ and for frequencies $\pm 1,5\%$.

Group A: Austria, Belgium, Denmark, Finland, France, Germany, Greece, Iceland, Ireland, Italy, Luxembourg, Netherlands, Norway, Portugal, Spain, Sweden, Switzerland, United Kingdom.

Group B: Czech Republic.

Sources: ES 201 970 [3] and FMS č.j. 6123/92.

A.2 Additional Tones

Call Progress Indication is an expression preferred in the ISDN environment and is covered in this clause on additional Network Tones.

A.2.1 Special Dial Tones

A.2.1.1 Secondary Dial Tone

Table A.5: Supervisory signal Secondary Dial Tone - Nominal cadences and frequencies

Country/Region	Cadence	Frequency
Group A (Harmonized)	Continuous	425 Hz
Group B	For expansion in next phase	For expansion in next phase
Group C	Not supported	N/A
Spain (national variance)	Continuous	600 Hz \pm 30 Hz

Unless otherwise specified the tolerances for cadences are $\pm 10\%$ and for frequencies $\pm 1,5\%$.

Group A: Austria, Belgium, Denmark, Finland, France, Germany, Greece, Hungary, Iceland, Ireland, Italy, Luxembourg, Netherlands, Norway, Portugal, Spain*, Sweden, Switzerland and United Kingdom.

Group B: For further study.

Group C: Czech Republic.

Sources: ES 201 970 [3], Independent studies by European Technology Services (EMEA) and FMS č.j. 6123/92.

NOTE: * Some variances exist in the provision of the supervisory tone and hence older analogue TE may only recognize the national (regional) variance.

A.2.1.2 Special (Intermittent or Stutter) Dial Tone

Table A.6: Supervisory signal Special Dial Tone - Nominal cadences and frequencies

Country/Region	Cadence		Frequency
Group A (Harmonized)	0,5 s on,	0,05 s off	425 Hz
Group B	Not supported		N/A
Czech Republic	0,165 s on,	0,165 s off	425 Hz \pm 20 Hz
	0,165 s on,	0,165 s off	
	0,165 s on,	0,165 s off	
	0,66 s on,	0,66 s off	

Unless otherwise specified the tolerances for cadences are $\pm 10\%$ and for frequencies $\pm 1,5\%$.

Group A: Austria, Belgium, Denmark, Finland, France, Germany, Greece, Iceland, Ireland, Italy, Luxembourg, Netherlands, Norway, Portugal, Spain, Sweden, Switzerland, United Kingdom - complete list still under study.

Group B: For further study.

Sources: ES 201 970 [3], Independent studies by European Technology Services (EMEA) and FMS č.j. 6123/92.

NOTE: * Some variances exist in the provision of the supervisory tone and hence older analogue TE may only recognize the national (regional) variance.

A.2.2 Special Information Tone

Table A.7: Supervisory signal Special Information Tone - Nominal cadences and frequencies

Country/Region	Cadence	Frequency
Group A (Harmonized)	0,33 s on, 0,33 s on, 0,33 s on, 1 s off	950 Hz, 1 400 Hz, 1 800 Hz
Czech Republic	0,33 s ± 0,07 s on, ≤ 0,03 s off 0,33 s ± 0,07 s on, ≤ 0,03 s off 0,33 s ± 0,07 s on, ≤ 0,03 s off 0,33 s ± 0,07 s on, 1 s ± 0,25 s off	950 Hz ± 50Hz, 1 400 Hz ± 50Hz, 1 800 Hz ± 50Hz
Hungary (variance on tolerances)	0,33 s ± 0,07 s on, ≤ 30 s off 0,33 s ± 0,07 s on, ≤ 30 s off 0,33 s ± 0,07 s on, ≤ 30 s off 0,33 s ± 0,07 s on, 1 s ± 0,25 s off	950 Hz ± 50Hz, 1 400 Hz ± 50Hz, 1 800 Hz ± 50Hz

Unless otherwise specified the tolerances for cadences are ±10 % and for frequencies ±1,5 %.

Group A: Austria, Belgium, Denmark, Finland, France, Germany, Greece, Hungary*, Iceland, Ireland, Italy, Luxembourg, Netherlands, Norway, Portugal, Spain, Sweden, Switzerland and United Kingdom.

Sources: ES 201 970 [3], Independent studies by European Technology Services (EMEA) and FMS č.j. 6123/92.

NOTE: * Some variances exist in the provision of the supervisory tone and hence older analogue TE may only recognize the national (regional) variance.

A.2.3 Congestion Tone

Table A.8: Supervisory signal Congestion Tone - Nominal cadences and frequencies

Country/Region	Cadence	Frequency
Group A (Harmonized)	0,25 s on, 0,25 s off	425 Hz
Czech Republic	0,165 s on, 0,165 s off	425 Hz ± 20 Hz

Unless otherwise specified the tolerances for cadences are ±10 % and for frequencies ±1,5 %.

Group A: Austria, Belgium, Denmark, Finland, France, Germany, Greece, Iceland, Ireland, Italy, Luxembourg, Netherlands, Norway, Portugal, Spain, Sweden, Switzerland and United Kingdom.

Sources: ES 201 970 [3], Independent studies by European Technology Services (EMEA) and FMS č.j. 6123/92.

A.2.4 Call Waiting Tone

Table A.9: Supervisory signal Call Waiting Tone - Nominal cadences and frequencies

Country/Region	Cadence	Frequency
Group A (Harmonized)	0,2 s on, 0,2 s off, 0,2 s on, 9 s off	425 Hz
Czech Republic	0,33 s on, 9 ± 0,5 s off	425 Hz ± 20 Hz

Unless otherwise specified the tolerances for cadences are ±10 % and for frequencies ±1,5 %.

Group A: Austria, Belgium, Denmark, Finland, France, Germany, Greece, Iceland, Ireland, Italy, Luxembourg, Netherlands, Norway, Portugal, Spain, Sweden, Switzerland and United Kingdom.

Sources: ES 201 970 [3], Independent studies by European Technology Services (EMEA), FMS č.j. 6123/92 and TR 101 041-2 [30].

Annex B (informative): Basic Call Information Flows

B.1 Purpose

The purpose of providing a series of basic call information flow scenarios is to assist developers of broadband equipment and associated technologies in understanding the various timing constraints already applied to legacy analogue terminals. The call flow uses an elementary "technology independent" naming convention to illustrate the types of event messages that may be passed within a broadband network, these are in no way definitive and are provided as an example.

B.2 Explanation of Basic Call Information Flows

Figure B.1 illustrates the basic call flow to establish a connection between an originating analogue TE (TE_O) and a terminating analogue TE (TE_T). Figure B.1 has not identified any additional signalling (e.g. QoS, security, billing etc) call flows that may be employed within a broadband network. The following clauses should be read in conjunction with the call flow diagram to assist in understanding the normal operating characteristics and event timing constraints associated with analogue TE.

B.2.1 Detection of loop state by the NTE

The NTE detects the electrical change in line state and notifies the appropriate call control network element (e.g. call agent). Refer to ES 201 970 [3] for electrical characteristics. This applies in two separate cases:

- 1) For an outgoing call, when the loop voltage is being applied by the NTE; and
- 2) For an incoming call, when Ringing Signal is being applied by the NTE.

B.2.2 Handling of supervisory tones by the NTE

In the specific broadband network implementation an NTE may just receive a message to generate Supervisory Tones locally. Alternatively, the Supervisory Tone is provided by an announcement player within the call control function and routed to the NTE as part of the in-band voice transmission.

B.2.3 Detection of Dial Tone by the TE

A TE with an auto-calling feature and Dial Tone detection will validate the electrical signal received prior to commencing the dial sequence within time T2. It should be noted that TE without Dial Tone detection or those employing blind-dial are required in most countries to wait before dialling, time T3 covers the minimum and maximum values specified in those countries listed in table 1 of EG 201 973-1 [33].

B.2.4 Handling of dialled digits by NTE

The NTE detects the dialled digits from the TE and either converts them to an appropriate address format, or in the case of DTMF digits these may be passed "in-band" for recognition by the call agent function. ES 201 235-3 [16] should be consulted for the correct reception of DTMF.

B.2.5 Detection of call progress tones by the TE

A TE with an auto-calling feature and Call Progress Tone detection will validate the electrical signal received prior to taking appropriate action (e.g. clearing the call attempt on receipt of Busy Tone).

B.2.6 Generation of Ringing Signal by the NTE

The NTE will receive a message to generate Ringing Signal locally, where the cadence and frequency of such ringing may either be fixed within the NTE or defined within specific elements of the network call control protocol.

B.2.7 Detection of Ringing signal

The TE detects Ringing signal and:

- 1) provides an audible or visible signal to the user; and/or
- 2) automatically answers.

B.2.8 Detection of on-hook state by the NTE

The NTE detects the electrical change in line state and notifies the appropriate call control network element (e.g. call agent). Refer to ES 201 970 [3] for electrical characteristics.

B.2.9 Generation of clearing signal by the NTE

The NTE may provide a polarity reversal or a k-break to indicate that the distant party has cleared the call.

B.2.10 Detection of clearing signal by the TE

A TE that implements auto-calling or auto-answering may detect a polarity reversal or a k-break, and clear the call in response. Alternatively, the TE may clear the call on loss of carrier, it is sends and received data (e.g. a modem or fax machine), or after a fixed period of time (e.g. an answering machine).

B.2.11 No Answer Time Out

In instances where the called party has not answered within a pre-defined time period, two scenarios are possible:

- a) the network will remove Ring Tone and play Release Tone (an alternative would be to perform *polarity reversal* or *k-break*) to indicate to the TE (User) to return on-hook; or
- b) a TE with an auto-calling feature (e.g. Facsimile) will normally and automatically return on-hook within between 60 s and 180 s, however, TE in regions outside the European Union (e.g. Belarus, Azerbaijan etc.) usually have a facility for this time-out period to be specified by the user - maximum 255 s. The reason for the user-defined period is to allow a modem/fax carrier signal to be returned on long distance or international calls when excessive delay is experienced (i.e. multiple PSTN gateways, satellite hop).

B.2.12 Handling modem and facsimile transmission by NTE

At the discretion of the implementing broadband network technology, the Originating and Terminating NTEs may switch to an ITU-T Recommendation G.711 [22] codec.

Upon the detection of fax or modem tones the codec at each end is switched to ITU-T Recommendation G.711 [22] for the remainder of the session. Additionally, echo cancellation is disabled in response to a disabling signal sent by some TE (fax or modem) consisting of a 2 100 Hz tone with periodic phase reversals as per ITU-T Recommendations G.165 [20] and G.168 [21]. After the TE session has completed, echo compensation would then have to be enabled. Alternatively, the NTE_O may employ fax relay. Fax relay involves demodulating the ITU-T Recommendation T.30 [25] transmission and sending control and image data over the IP network. At NTE_T, the received data is remodulated and sent to the fax terminal using another ITU-T Recommendation T.30 [25] session. Refer to ITU-T Recommendation T.38 [26].

Table B.1: Timing associated to the correct operation of analogue TE

Timer	Description	Value
T1	Time between the TE going off-hook and provision of Dial Tone	≤ 5 s
T2	Time between the Dial Tone detection and the start of dial sequence	≤ 8 s See TBR 021 [19]
T3	Time between the TE going off-hook and the start of dial sequence - TE without Dial Tone detection or those employing blind-dialling	≥ 5 s ≤ 20 s
T4	Time between the end of dial sequence and modem/fax carrier detection	$50 \leq 255$ s
T5	Time between the end of the call and the transition into the on-hook state	50 ms to 200 ms

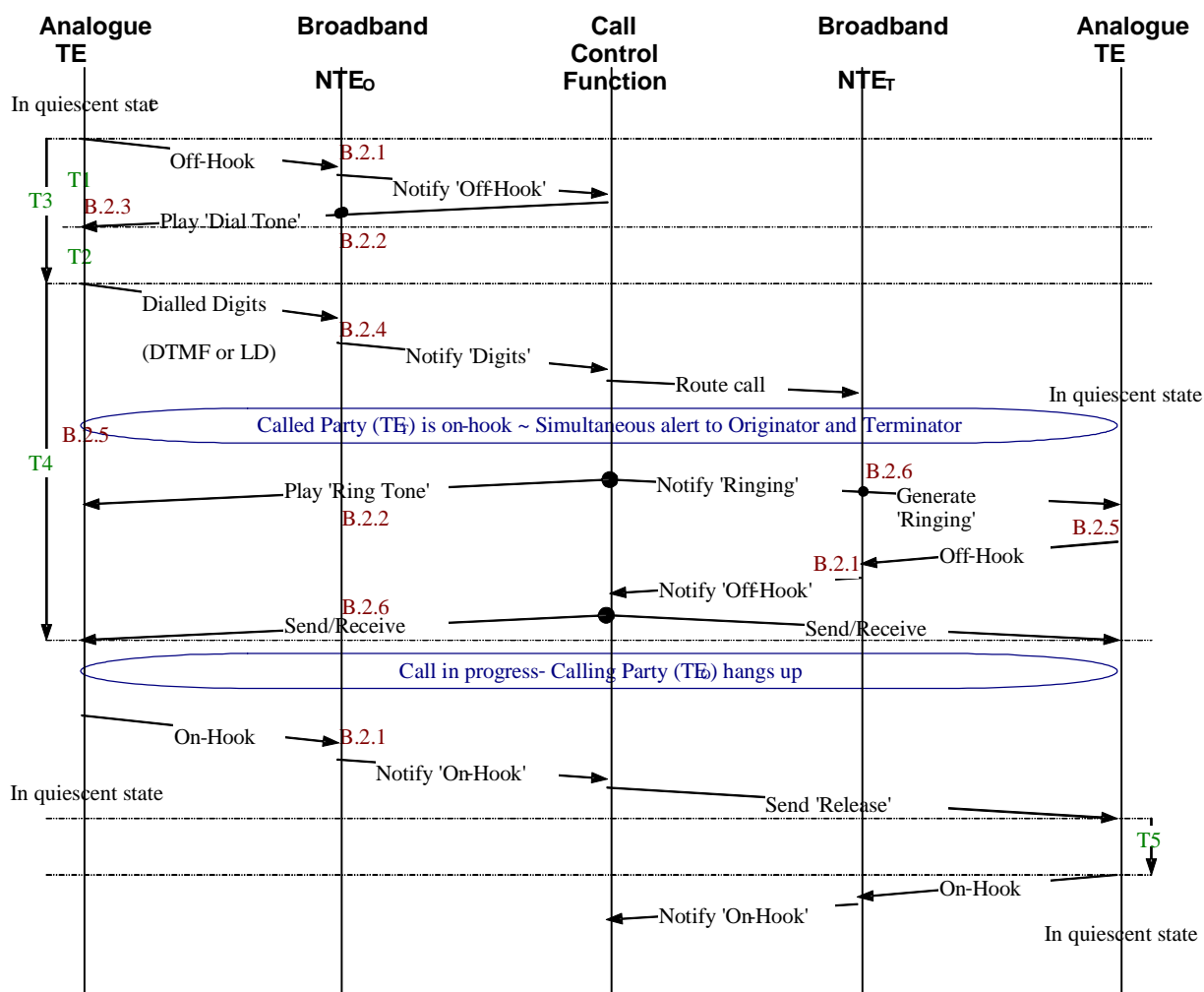

Figure B.1: Basic Call Flow - successful connection of Analogue TE

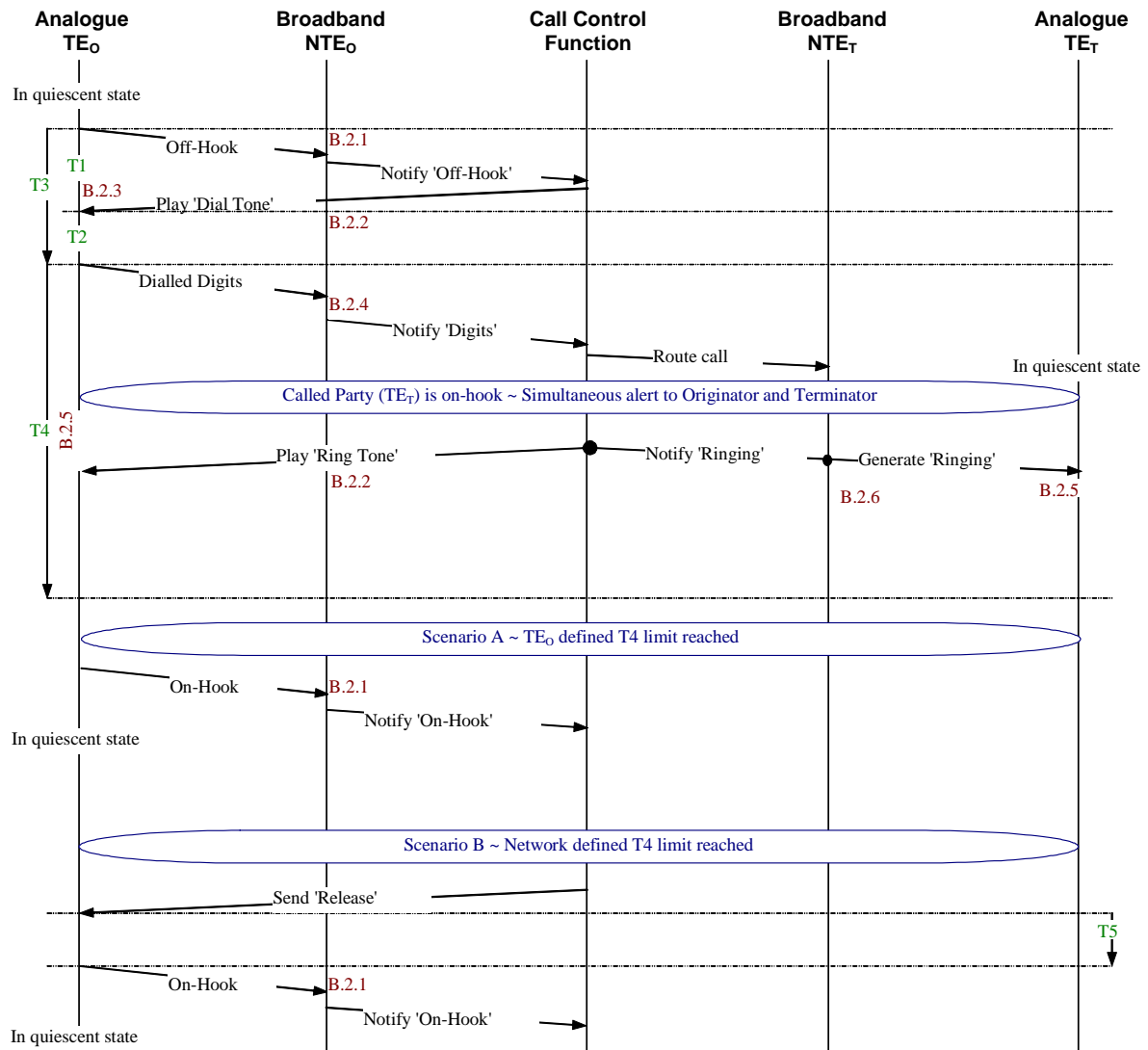

Figure B.2: Basic Call Flow - unsuccessful connection NO ANSWER

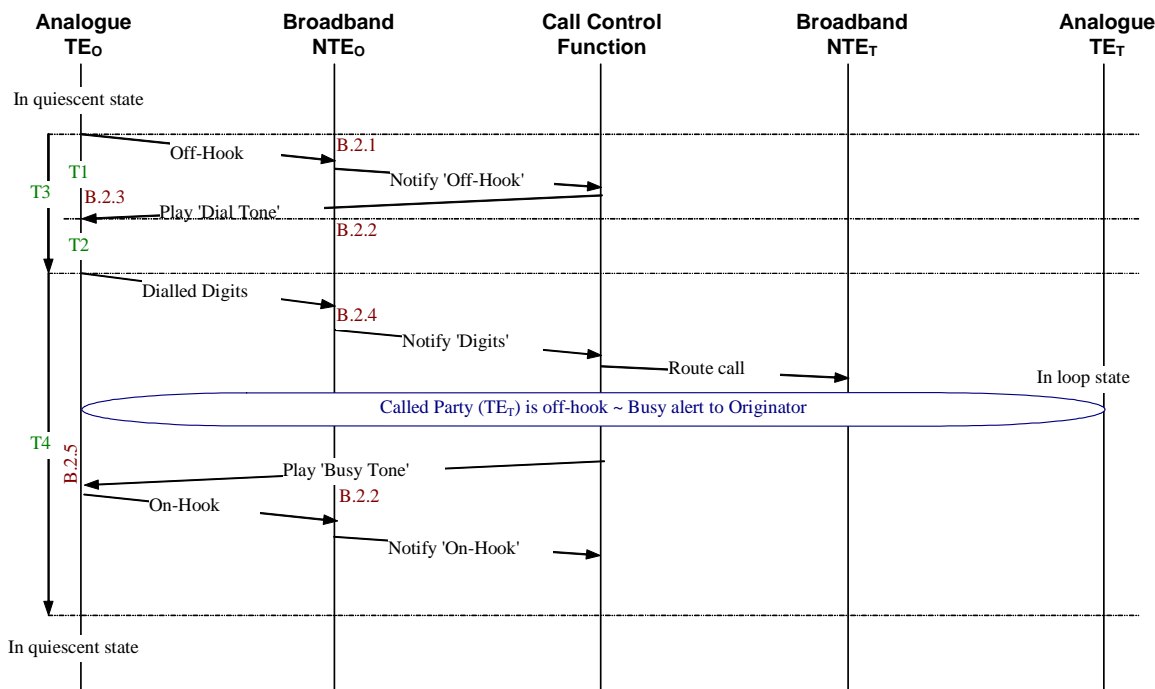

Figure B.3: Basic Call Flow - unsuccessful connection BUSY

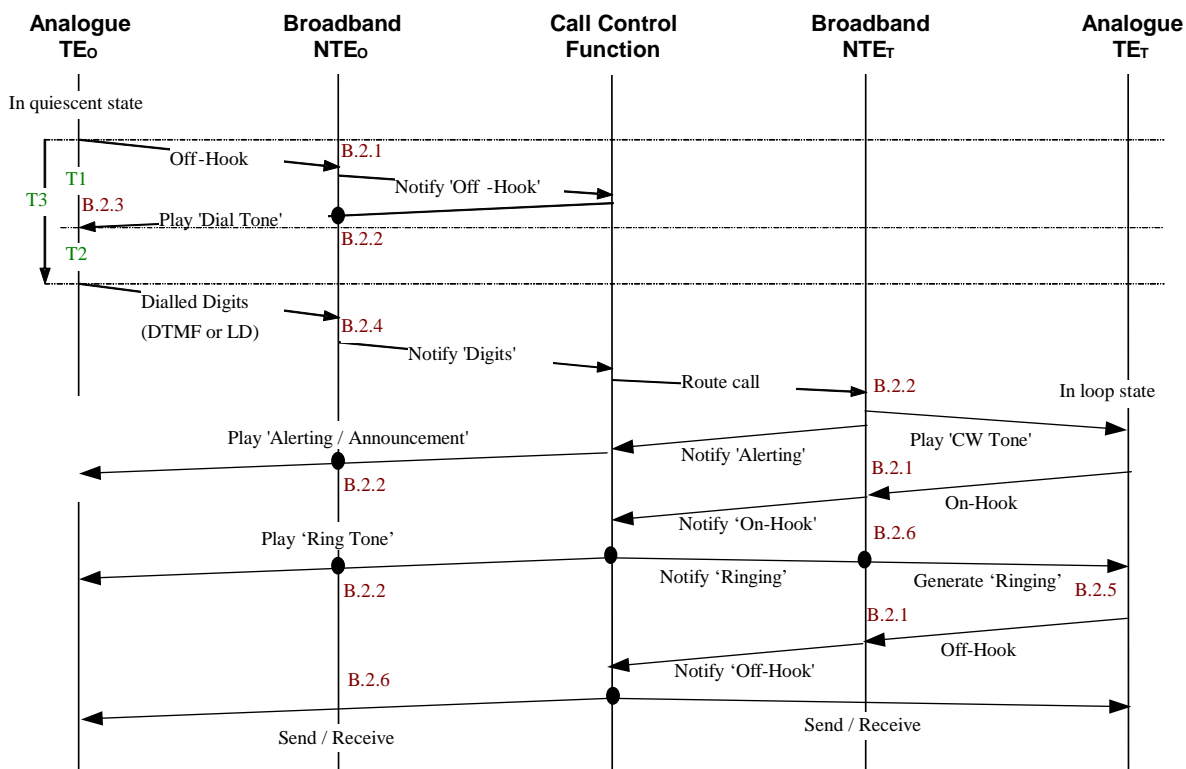

Figure B.4: Basic Call Flow - successful connection of Analogue TE BUSY - CALL WAITING

Annex C (informative): Bibliography

ETSI TR 101 730 (V1.1.1): "Publication of interface specification under R&TTE directive 1999/5/EC; Guidelines for describing analogue interfaces".

ETSI TR 101 730 (V2.1.1): "Access and Terminals (AT); Publication of interface specification under Directive 1999/5/EC; Guidelines for describing analogue interfaces".

Directive 1999/5/EC of the European Parliament and of the Council of 9 March 1999 on radio equipment and telecommunications terminal equipment and the mutual recognition of their conformity (R&TTE Directive).

ITU-T Recommendation V.17 (1991): "A 2-wire modem for facsimile applications with rates up to 14 400 bit/s".

ITU-T Recommendation V.90 (1998): "A digital modem and analogue modem pair for use on the Public Switched Telephone Network (PSTN) at data signalling rates of up to 56 000 bit/s downstream and up to 33 600 bit/s upstream".

ITU-T Recommendation V.92 (2000): "Enhancements to Recommendation V.90".

GOST 26557-85: "Russian Federal Technical Standard for Telephone Terminal Equipment".

ETSI EG 201 120: "Public Switched Telephone Network (PSTN); Method of rating terminal equipment so that it can be connected in series and/or in parallel to a Network Termination Point (NTP)".

ETSI EG 201 184: "2-wire analogue voice band interfaces; Multiple line terminal equipment specific characteristics".

ETSI EG 201 185: "Terminal support interface for harmonized analogue PSTN terminals".

ETSI TR 101 149: "2-wire analogue voice band interfaces; Terminal Equipment transmitting voice signals; Test simulation for level limitation requirements".

ETSI TR 102 088: "Public Switched Telephone Network (PSTN); Subscriber line protocol for Advice of Charge (AoC) display services".

ETSI ES 200 778-3: "Access and Terminals (AT); Analogue access to the Public Switched Telephone Network (PSTN); Protocol over the Local loop for display and related services; Terminal equipment requirements; Part 3: Protocol Implementation Conformance Statement (PICS) proforma specification; On-Hook and Off-Hook".

ETSI TR 101 844: "Access and Terminals (AT); Study of the global usage and acceptance of non-radio TBRs and associated documents".

ETSI TR 101 963: "Access and Terminals (AT); Report on the Requirements of European Cable Industry for Implementation of IPCablecom Technologies; Identification of high level requirements and establishment of priorities".

ITU-T Recommendation H.323: "Packet-based multimedia communications systems".

ETSI TR 101 041-1: "Human Factors (HF); European harmonization of network generated tones; Part 1: A review and recommendations".

FMS č.j. 6123/92: "Czech Federal Technical Specification for Telephone Terminal Equipment".

GOST 26557-85: "Russian Federal Technical Standard for Telephone Terminal Equipment".

ITU-T Recommendation Q.552: "Transmission characteristics at 2-wire analogue interfaces of digital exchanges".

ETSI Draft ES 203 021: "Access and Terminals (AT); Harmonized basic attachment requirements for Terminals for connection to analogue interfaces of the Telephone Networks; Update of the technical contents of Analogue PSTN TBR's for a global non-regulatory application".

History

Document history		
V1.1.1	December 2002	Publication as TR 101 973-2
V1.2.1	December 2004	Membership Approval Procedure MV 20050218: 2004-12-21 to 2005-02-18