

**Services and Protocols for Advanced Networks (SPAN);  
Narrowband Services over ATM;  
Loop Emulation Service (LES) using AAL2;  
Part 1: LES Interface specification**

[ATM Forum Specification AF-VMOA-0145.000 (2000), modified]

---



---

**Reference**

DEG/SPAN-130104-1

---

**Keywords**

AAL, ATM, endorsement, V5 Interface

**ETSI**

---

650 Route des Lucioles  
F-06921 Sophia Antipolis Cedex - FRANCE

Tel.: +33 4 92 94 42 00 Fax: +33 4 93 65 47 16

Siret N° 348 623 562 00017 - NAF 742 C  
Association à but non lucratif enregistrée à la  
Sous-Préfecture de Grasse (06) N° 7803/88

---

**Important notice**

Individual copies of the present document can be downloaded from:

<http://www.etsi.org>

The present document may be made available in more than one electronic version or in print. In any case of existing or perceived difference in contents between such versions, the reference version is the Portable Document Format (PDF). In case of dispute, the reference shall be the printing on ETSI printers of the PDF version kept on a specific network drive within ETSI Secretariat.

Users of the present document should be aware that the document may be subject to revision or change of status. Information on the current status of this and other ETSI documents is available at <http://www.etsi.org/tb/status/>

If you find errors in the present document, send your comment to:  
editor@etsi.fr

---

**Copyright Notification**

No part may be reproduced except as authorized by written permission.  
The copyright and the foregoing restriction extend to reproduction in all media.

© European Telecommunications Standards Institute 2001.  
All rights reserved.

---

## Intellectual Property Rights

IPRs essential or potentially essential to the present document may have been declared to ETSI. The information pertaining to these essential IPRs, if any, is publicly available for **ETSI members and non-members**, and can be found in ETSI SR 000 314: "*Intellectual Property Rights (IPRs); Essential, or potentially Essential, IPRs notified to ETSI in respect of ETSI standards*", which is available from the ETSI Secretariat. Latest updates are available on the ETSI Web server (<http://www.etsi.org/ipr>).

Pursuant to the ETSI IPR Policy, no investigation, including IPR searches, has been carried out by ETSI. No guarantee can be given as to the existence of other IPRs not referenced in ETSI SR 000 314 (or the updates on the ETSI Web server) which are, or may be, or may become, essential to the present document.

---

## Foreword

This ETSI Guide (EG) has been produced by ETSI Technical Committee Services and Protocols for Advanced Networks (SPAN).

The present document is part 1 of a multi-part deliverable covering the Narrowband Services over ATM; Loop Emulation Service (LES) using AAL2, as identified below:

**Part 1:** "**LES interface specification [ATM Forum Specification AF-VMOA-0145.000 (2000), modified]**";

Part 2: "Protocol Implementation Conformance Statement (PICS) proforma specification".

# 1 Scope

The present document specifies the ETSI endorsement of the ATM Forum specification AF-VMOA-0145.000 (2000-07) 'Loop emulation service using AAL2'.

The present document provides appropriate selection or restriction of options and, if necessary, modifications and amendments to the ATM Forum specification in order to meet the requirements of markets where ETSI V5 standards are prevalent.

# 2 Endorsement notice

The elements of ATM-Forum specification 'Loop emulation service using AAL2 AF-VMOA-0145.000 (2000)', apply, with the following modifications:

NOTE: New or modified text is indicated using sidebars. In addition, underlining and/or strike-out are used to highlight detailed modifications where necessary.

## Clause 1.3

Replace text in clause '1.3 Abbreviations' by:

For the purposes of the present document, the following abbreviations apply: AAL2 ATM Adaptation Layer type 2

AAL5	ATM Adaptation Layer type 5
AAL2 VCC	an ATM VCC using AAL2
AAL5 VCC	an ATM VCC using AAL5
ADPCM	Adaptive Differential Pulse Code Modulation
ADSL	Asymmetric Digital Subscriber Line
AINI	ATM Inter Network Interface
AIS	Alarm Indication Signal
AppId	APPLication ID
AN	Access Node
<del>ANSI</del>	<del>American National Standards Institute</del>
ATM	Asynchronous Transfer Mode
B-HLI	Broadband - High Layer Information
BCC	Bearer Channel Connection protocol
BRI	Basic Rate Interface
CAS	Channel Associated Signalling
CCS	Common Channel Signalling
CDV	Cell Delay Variation
CID	AAL2 Channel Identifier
CMIP	Common Management Information Protocol
CO	Central Office
CO-IWF	Central Office Interworking Function
CP-IWF	Customer Premises Interworking Function
CPS	Common Part Sublayer
<del>CRV</del>	<del>Call Reference Value</del>
<del>CSC</del>	<del>Common Signaling Channel</del>
DSS1	Digital Subscriber Signalling System number 1
DSS2	Digital Subscriber Signalling System number 2
DTMF	Dual Tone Multi-Frequency
ELCP	Emulated Loop Control Protocol
EOC	Embedded Operations Channel
ETSI	European Telecommunications Standards Institute
FAX	Facsimile
FCS	Frame Check Sequence
FSK	Frequency Shift Keyed
<del>GIT</del>	<del>Generic Identifier Transport</del>
HDLC	High-level Data Link Control

HDLC-F	HDLC - Framing
HDSL	High-speed Digital Subscriber Line
HFC	Hybrid Fiber Coax
<del>IDT</del>	<del>Integrated Digital Terminal</del>
IE	Information Element
IEC	International Electro-technical Commission
ILMI	Integrated Local Management Interface
ISDN	Integrated Services Digital Network
ISO	International Standards Organization
ITU-T	International Telecommunications Union, Telecommunications sector
IWF	Interworking Function
LAPD	Link Access Protocol for ISDN D-channel
LAPV5	Link Access Protocol for V5-interface
LAPV5-DL	LAPV5 Data Link sublayer
LE	Local Exchange
LES	Loop Emulation Service
MBS	Maximum Burst Size
MIB	Management Information Base
OAM	Operation Administration and Maintenance
OUI	Organizational Unit Identifier
PBX	Private Branch exchange
PCM	Pulse Code Modulation
PDU	Protocol Data Unit
PDV	Packet Delay Variation
PNNI	Private Network-to-Network Interface
PRS	Primary Reference Source
PSTN	Public Switched Telephone Network
PVC	Permanent Virtual Circuit
RDI	Remote Defect Indication
<del>RDT</del>	<del>Remote Digital Terminal</del>
RFC	Request For Comments
SAAL	Signalling ATM Adaptation Layer
SAPI	Service Access Point Identifier
SAR	Segmentation And Reassembly
SCR	Sustainable Cell Rate
SDU	Service Data Unit
SHDSL	Symmetric High-speed Digital Subscriber Line
SID	Silence Insertion Descriptor
<del>SigVCCI</del>	<del>Signaling VCCI</del>
SNI	Service Node Interface
SNMP	Simple Network Management Protocol
SPVC	Soft Permanent Virtual Circuit
SSCS	Service Specific Convergence Sublayer
SSSAR	Service Specific SAR
SSTED	Service Specific Transmission Error Detection
SSTED-CI	SSTED - Congestion Indication
SSTED-LP	SSTED - Loss Priority
SSTED-UU	SSTED - User-to-User indication
SVC	Switched Virtual Circuit
TDD	Telecommunications Device for the Deaf
TDM	Time Division Multiplexing
TED	Transmission Error Detection
<del>TMC</del>	<del>Timeslot Management Channel</del>
TMF	Timeslot Management Function
UNI	User Network Interface
UII	User-to-User Indication
VCC	Virtual Channel Connection (where it may be a PVC, SPVC, or SVC)
VCCI	VCC Identifier
xDSL	any variety of Digital Subscriber Line, e.g. ADSL or SDSL

## Clause 1.8

Replace text in clause '1.8 CP-IWF functionality' by:

Depending on the configuration, a CP-IWF includes a subset of the following functions:

- physical layer interfaces to customer-located telephony equipment such as analog POTS; or basic rate ISDN or channelized DS1;
- signalling Interworking, to receive signalling from and insert signalling into both the narrowband interfaces, and the ATM broadband interfaces;
- SSCS User functions, including e.g. voice codecs for speech compression, echo cancellers and Fax demodulation/remodulation units;
- AAL2 SSCS functions, to format User information into packets for transport on AAL2 connections;
- AAL2 CPS functions, for multiplexing AAL2 connections into ATM cells;
- ATM VCC Management, to allocate and deallocate ATM VCCs to distant CO-IWFs as needed to support the traffic;
- AAL2 Channel Management, to allocate and de-allocate AAL2 channels to distant CO-IWFs as needed to support the traffic;
- SAAL functions to support ATM UNI signalling activity for the establishment of SVCs on demand;
- a management interface to allow management of the telephony functions remotely from the CO-IWF.

## Clause 1.9

Add the following introductory text in clause '1.9 References':

References may be made to:

- a) specific versions of publications (identified by date of publication, edition number, version number, etc.), in which case, subsequent revisions to the referenced document do not apply; or
- b) all versions up to and including the identified version (identified by "up to and including" before the version identity); or
- c) all versions subsequent to and including the identified version (identified by "onwards" following the version identity); or
- d) publications without mention of a specific version, in which case the latest version applies.

A non-specific reference to an ETS shall also be taken to refer to later versions published as an EN with the same number.

### Clause 1.9.1

Replace text in clause '1.9.1 Normative' by:

~~The following references contain provisions that, through reference in this text, constitute provisions of this specification. At the time of publication, the editions indicated were valid. All references are subject to revision, and parties to agreements based on this specification are encouraged to investigate the possibility of applying the most recent editions of the references indicated below.~~

- [1] DSL Forum TR-017 (1999): "ATM over ADSL Recommendations".
- [2] ~~Void. ANSI T1.401-1993, Interface between carriers and customer installations— analog voice grade switched access lines using loops start and ground start signaling.~~
- [3] ~~Void. ANSI T1.405-1996, Network to customer installation interfaces— direct inward dialing analog voice grade switched access using loop reverse battery signaling.~~

- [4] Void. ~~ANSI T1.409-1996, Network to customer installation interfaces-- analog voice grade special access lines using E&M signaling.~~
- [5] Void. ~~ANSI T1.602-1996, Integrated services digital network (ISDN) -- Data link layer signaling specification for application at the user-network interface.~~
- [6] Void. ~~ANSI T1.607-1990 (R-1995) and ANSI T1.607a-1996, Digital subscriber signaling system number 1 (DSS1) -- layer 3 signaling specification for circuit switched bearer services.~~
- [7] ATM Forum af-pnni-0055.000 (1996): "Private Network-Network Interface Specification Version 1.0".
- [8] ATM Forum af-sig-0061.000 (1996): "ATM User-Network Interface (UNI) Signalling Specification Version 4.0".
- [9] ATM Forum af-ilmi-0065.000 (1996): "Integrated Local Management Interface (ILMI) Specification Version 4.0".
- [10] ATM Forum af-vtoa-0113.000 (1999): "ATM Trunking using AAL2 for Narrowband Services".
- [11] ATM Forum af-cs-0125.000 (1999): "ATM Inter-Network Interface (AINI) Specification".
- [12] ETSI ETS 300 012-1 (1998): "Integrated Services Digital Network (ISDN); Basic User-Network Interface (UNI); Layer 1 specification".
- [13] ETSI EN 300 324-1 (V2.1.1 2000~~4999~~): "V interfaces at the digital Local Exchange (LE); V5.1 interface for the support of Access Network (AN); Part 1: V5.1 interface specification".
- [14] ETSI EN 300 347-1 (V2.2.2): "V interfaces at the digital Local Exchange (LE); V5.2 interface for the support of Access Network (AN); Part 1: V5.2 interface specification".
- [15] ETSI ETS 300 402-1 (1995): "Integrated Services Digital Network (ISDN); Digital Subscriber Signalling System No. 1 (DSS1) protocol; Data link Layer; Part 1: General aspects [ITU-T Recommendation Q.920 (1993), modified]".
- [16] ETSI ETS 300 402-2 (1995): "Integrated Services Digital Network (ISDN); Digital Subscriber Signalling System No. 1 (DSS1) protocol; Data link Layer; Part 2: General protocol specification [ITU-T Recommendation Q.921 (1993), modified]".
- [17] IETF STD0002 (RFC1700) (1994): "Assigned numbers".
- [18] ITU-T Recommendation G.991.2: "Single-Pair High-Speed Digital Subscriber Line (SHDSL) transceivers".
- [19] ITU-T Recommendation G.992.1 (1999): "Asymmetric Digital Subscriber Line (ADSL) transceivers".
- [20] ITU-T Recommendation G.992.2 (1999): "Splitterless Asymmetric Digital Subscriber Line (ADSL) transceivers".
- [21] ITU-T Recommendation G.964 (1994): "V-Interfaces at the digital local exchange (LE) - V5.1 interface (based on 2 048 kbit/s) for the support of access network (AN)".
- [22] ITU-T Recommendation G.965 (1995): "V-Interfaces at the digital local exchange (LE) - V5.2 interface (based on 2 048 kbit/s) for the support of access network (AN)".
- [23] ITU-T Recommendation I.363.2 (1997): "B-ISDN ATM Adaptation Layer (AAL) type 2 specification".
- [24] ITU-T Recommendation I.363.5 (1996): "B-ISDN ATM Adaptation Layer specification: Type 5 AAL".
- [25] ITU-T Recommendation I.366.1 (1998): "Segmentation and Reassembly Service Specific Convergence Sublayer for the AAL type 2".

- [26] ITU-T Recommendation I.366.2 (1999): "AAL Type 2 service specific convergence sublayer for narrowband services".
- [27] ITU-T Recommendation I.430 (1995): "Basic user-network interface - Layer 1 specification".
- [28] ITU-T Recommendation I.432.1 (1999): "B-ISDN user-network interface- Physical layer specification: General characteristics".
- [29] ITU-T Recommendation I.432.2 (1999): "B-ISDN user-network interface - Physical layer specification: 155 520 kbit/s and 622 080 kbit/s operation".
- [30] ITU-T Recommendation I.432.3 (1996): "B-ISDN user-network interface - Physical layer specification: 1544 kbit/s and 2048 kbit/s operation".
- [31] ITU-T Recommendation I.432.4 (1999): "B-ISDN user-network interface - Physical layer specification: 51 840 kbit/s operation".
- [32] ITU-T Recommendation I.432.5 (1997): "B-ISDN user-network interface - Physical layer specification: 25 600 kbit/s operation".
- [33] ITU-T Recommendation I.610 (1999): "B-ISDN operation and maintenance principles and functions".
- [34] ITU-T Recommendation Q.2931 (1995): "Broadband Integrated Services Digital Network (B-ISDN) - Digital Subscriber Signalling System No. 2 (DSS 2) - User-Network Interface (UNI) Layer 3 specification for basic call/connection control".
- [35] ~~ITU-T Q.2941.2, 1999, Broadband Integrated Services Digital Network (B-ISDN) - Digital Subscriber Signalling System No. 2 (DSS 2) - Generic identifier transport (Draft).~~
- [36] ITU-T Recommendation Q.921 (1997): "ISDN user-network interface - Data link layer specification".
- [37] ITU-T Recommendation Q.931 (1998): "ISDN user-network interface layer 3 specification for basic call control".
- [38] ITU-T Recommendation V.8 (1998): "Procedures for starting sessions of data transmission over the general switched telephone network".
- [39] ITU-T Recommendation V.25 (1996): "Automatic answering equipment and general procedures for automatic calling equipment on the general switched telephone network including procedures for disabling of echo control devices for both manually and automatically established calls".
- [40] ~~Telecordia Generic Requirements GR-303-CORE Issue 2, 1998, Integrated Digital Loop Carrier System Generic Requirements, Objectives, and Interface.~~

NOTE: ITU-T Recommendations G.964 and G.965 are functionally equivalent to ETSI EN 300 324-1 and ETSI EN 300 347-1 respectively. In cases where detail differences exist between the ITU-T and ETSI versions of the specifications, the ETSI versions of the specifications should apply.

## Clause 1.9.2

Replace text in clause '1.9.2 Informative' by:

- [1] ~~Void. ANSI T1.101-1994, Telecommunications Synchronization Interface Standard.~~
- [2] ~~Void. ANSI T1.508-1992, Network Performance Loss Plan for Evolving Digital Networks.~~
- [3] DSL Forum TR-036 ~~WT-043 Rev 0.5~~ (2000): "Requirements for Voice over DSL".
- [4] ITU-T Recommendation G.114 (1996): "One-way transmission time".
- [5] ITU-T Recommendation G.131 (1996): "Control of talker echo".
- [6] ITU-T Recommendation G.168 (1997): "Digital network echo cancellers".



- [7] ~~Void~~Telecordia Technical Reference TR-TSY-000008 Issue 2, 1987, Digital Interface between the SLC<sup>®</sup>96 Digital Loop Carrier and a Local Digital Switch.
- [8] ~~Void~~Telecordia Technical Reference TR-NWT-000057 Issue 2, 1993, Functional Criteria for Digital Loop Carrier Systems.
- [9] ~~Void~~Telecordia TR-NWT-000393, 1991, Generic Requirements For ISDN Basic Access Digital Subscriber Lines.
- [10] United Kingdom V5 PSTN Mapping Requirements SSPE/Specification/001-1.
- [11] British Standard BS 7378-3 (1998): "Apparatus for connection to public telecommunications systems using the Digital Access Signalling System No. 2 (DASS 2) via a 2 048 kbit/s CCITT Recommendation G.703 interface. Requirements for apparatus for connection to Channel Associated Signalling Systems (CASS)".

## Clause 2

Replace introductory text in clause '2 Interfaces supported' by:

The present document identifies the user-side interfaces supported at the CP-IWF, and specifies the ATM interfaces at both the CP-IWF and the CO-IWF. It does not define the interfaces on the network side of the CO-IWF, because it is intended that the protocol operating between the IWFs should offer generic support for the delivery of narrowband services at the CP-IWF user-side interfaces in a manner that is independent of the Service Node Interface at the CO-IWF.

It is anticipated that some implementations of the CO-IWF will support narrowband Service Node interfaces to circuit-switched voice networks in accordance with ~~well known access network interface specifications such as Telecordia GR-303, Telecordia TR-008,~~ ETSI V5.1 (ITU-T Recommendation G.964) and ETSI V5.2 (ITU-T Recommendation G.965). To assist implementors with the development of such devices, a series of ~~informative~~ appendices are included with the present document which provide examples of mappings between the protocols that exist across these ~~well known~~ V5 interfaces, and the protocols that are defined in the present document between CO-IWF and CP-IWF.

## Clause 2.1

Replace text in clause '2.1 Physical layer' by:

The interface between a CO-IWF and the ATM network should be any ATM interface defined by the ATM Forum or by the ITU-T recommendation I.432.x series of UNI recommendations, or the following interface types:

- ATM over ADSL in accordance with DSL Forum TR-017;
- other ATM physical layer specifications for SDSL, HFC and wireless transmission systems depending on the application.

Examples of SDSL presently being standardized are:

- ITU-T SHDSL (Recommendation G.991.2, Single-pair high speed digital subscriber line (SHDSL) transceivers);
- ~~ANSI HDSL2 (High bit rate Digital Subscriber Line 2nd Generation (HDSL2));~~
- ETSI SDSL (Symmetric single pair high bit rate digital subscriber line (SDSL) transmission system on metallic local lines).

## Clause 2.2

Replace text in clause '2.2 CP-IWF User side Interfaces' by:

A CP-IWF should support appropriate interfaces for connection to customer-located telephony equipment. These interfaces may include analog telephony and basic rate ISDN, ~~and DS1 with robbed bit signaling.~~

Specifications for these interfaces include the following:

- Analog telephony interface in accordance with ~~ANSI T1.401, ANSI T1.405, ANSI T1.409, Telecordia TR-NWT-000057~~ or equivalent a national standard or equivalent network operator specification;
- Basic rate ISDN interface in accordance with ITU-T Recommendation I.430, ~~Telecordia TR-NWT-000393, ETSI ETS 300 012,~~ or equivalent national standard or network operator specification.

Other line side customer interfaces depending on the application.

## Clause 3.3

Replace introductory text in clause '3.3 Signalling' by:

The CP-IWF and the CO-IWF shall support the transport of signalling information across the ATM network between the narrowband interface of the customer-located telephony equipment at the CP-IWF, and the Service Node Interface at the CO-IWF.

This clause provides protocol reference models that illustrate the interworking between the narrowband user side interfaces and the ATM network side interface at the CP-IWF.

Protocol reference models for the CO-IWF are not illustrated here because the present document does not define the Service Node Interface at the CO-IWF. The ATM network side protocols are terminated at the CO-IWF in the same manner as illustrated here for the CP-IWF. ~~Example p~~ Protocol reference models for the CO-IWF can be found in ~~informative~~ appendixes B and C that describes the operation of the CO-IWF with ~~specific~~ V5 based narrowband Service Node Interfaces ~~including GR-303 and V5.~~

## Clause 3.7

Replace text in clause '3.7 Echo cancellation' by:

For voice applications, the combination of delay and echo causes an impairment to speech quality which is subjectively determined and which may require measures to be taken to minimize the impact. Since most causes of delay cannot be avoided or minimized, reduction of echo must be considered.

Delay is introduced into an end-to-end connection by a variety of factors including:

- Packetization.
- Compression algorithms.
- Physical transmission time.
- Switching of ATM cells in the network.
- Queuing.
- Build-out delay for accommodating PDV.

Echo is caused by:

- Hybrids used to go from 4-wire circuits to 2-wire circuits (typically at analog loops).
- Acoustical feedback at the end user's terminal (especially when the user places a telephone receiver down on a hard surface).

DSL Forum TR-036~~WT-043~~ suggests that the one-way delay introduced in the voice path by systems that implement LES-AAL2 with typical DSL access connections is of the order of 20 ms to 25 ms. This is well in excess of the upper limit of delay specified in ANSI T1.508 for digital access networks without echo cancellation. The use of echo cancellation is therefore strongly advised.

Applicable ITU-T Recommendations such as G.131, G.114, G.165, G.168, and other references contain information on this subject. Generally, the control of echo is best performed as close to the source of that echo as practicable. The present document addresses neither the methods used to determine the need for nor the procedures for applying echo cancellation. An IWF may support echo cancellation.

#### Clause 4.1.1

Replace text in clause '4.1.1 Application Identifier (AppId)' by:

The Application Identifier (AppId) specifies protocol combinations used between IWFs. Values are defined under the ATM Forum OUI for the following:

- Loop Emulation Service using CAS (POTS only) without ELCP.
- Loop Emulation Service using PSTN signalling (POTS only) without ELCP.
- Loop Emulation Service using PSTN signalling (POTS only) with ELCP.
- Loop Emulation Service using DSS1 in support of BRI (BRI only) without ELCP.
- Loop Emulation Service using DSS1 in support of BRI (BRI only) with ELCP.
- Loop Emulation Service using CAS in support of POTS and DSS1 in support of BRI (without ELCP).
- Loop Emulation Service using PSTN signalling in support of POTS and DSS1 in support of BRI (without ELCP).
- Loop Emulation Service using PSTN signalling in support of POTS and DSS1 in support of BRI (with ELCP).
- ~~Loop Emulation Service using other variety of CCS.~~
- ~~Unspecified mode of Loop Emulation Service.~~

#### Clause 5.1.1.1

Replace text in clause '5.1.1.1 Supervisory signalling' by:

Supervisory line states such as on-hook, off-hook, idle and ringing are conveyed between the CP-IWF and the CO-IWF in the form of 4-bit codewords known as ABCD bits. Each value of the ABCD bit codeword represents a specific supervisory line state. IWFs that support CAS shall transport the CAS ABCD bits to the other IWF as type 3 packets using AAL2 in accordance with the procedures in Annex L of I.366.2. An IWF may have the capability to debounce the CAS bits before transport over the ATM network in order to reduce unnecessary transmission.

The CP-IWF shall map the CAS ABCD bits associated with each AAL2 channel to analog line states at the POTS port that corresponds with this channel. The mapping between analog line states and ABCD bit codewords is outside the scope of this specification and is defined in the related CAS national standard (e.g. BS 7378-3 for the UK) or equivalent network specification. ~~shall be as defined in Telcordia GR-303 CORE tables 12-3 through 12-6.~~

#### Clause 5.1.2.1.3

Replace text in clause '5.1.2.1.3 Country/Operator specific usage of PSTN messages' by:

The PSTN message set defined in clause 13 of ETSI EN 300 324-1 and its associated information elements provides a flexible and comprehensive solution to signalling analog line states, taking into account the many variations that are seen in individual national implementations of analog POTS.

Most real implementations of POTS require only a small subset of the information elements that are specified for use with PSTN protocol messages. Details of the PSTN messages and information elements that are needed for any specific implementation should be available from the service provider that is making use of this implementation.

An example usage of PSTN messages to support analog POTS in North American markets is given in Appendix D.

## Clause 9.2

Replace text in clause '9.2 Timing considerations' by:

A CO-IWF shall derive its timing from the Service Node interface.

A CP-IWF should derive its timing by one of the following methods.

- from the physical layer timing derived from the xDSL or HFC receiver interface, corrected if appropriate by adequate Network Timing Reference information as specified by, for example, T1.413 Issue 2;
- by deducing timing information which is implicit in the rate of arrival of incoming AAL2 packets from the CO-IWF.

In both cases, the objective is that the timing used by the CP-IWF should be traceable to a Primary Reference Source. Information on the distribution of network timing may be found in ~~ANSI T1.101~~ and ISO/IEC 11573. If the physical layer timing derived from the xDSL or HFC receiver interface at the CP-IWF is not traceable to a PRS, then the CP-IWF should not use this method to obtain timing information, but should instead deduce timing information from the rate of arrival of AAL2 packets from the CO-IWF.

A CP-IWF may use a free-running local timing source. The use of a free-running clock less accurate than Stratum 3 is not recommended since it may result in service impairments due to periodic clock slips.

## Appendix A, clause A.1

Replace text in clause 'A.1 Operation of CO-IWF' by:

A CO-IWF may operate in "concentrated" or "non-concentrated" mode. In non-concentrated mode, each timeslot in each TDM connection between CO-IWF and Service Node is statically allocated to a specific AAL2 channel. In concentrated mode, the allocation of timeslots to AAL2 channels is carried out dynamically in the CO-IWF, as and when originating or terminating call attempts occur.

The operation of the CO-IWF, in terms of the functionality depicted in figure A-1, is described in the following paragraphs for the case of concentrated access mode. In the case of non-concentrated access mode, the Call Handling function is null and signalling and bearer information is passed through the IWF according to a fixed mapping of narrowband time slots to AAL2 channels.

~~E1/DS1~~ TDM trunks terminate on a Multiplexer/Demultiplexer function, which distributes the individual 64 kbit/s channels between the trunks and the Switch function. The narrowband signalling associated with the individual 64 kbit/s channels, whether out-of band or -in-band is extracted via the Switch by the Signalling Interworking function. This narrowband signalling includes both end-to-end signalling in CAS or CCS format that will be forwarded over the ATM network to the CP-IWF, and local signalling supporting the Timeslot Management Function.

The Signalling Interworking function separates the local TMF signalling from the end-to-end CAS or CCS signalling, and passes the TMF signalling to the Call Handling Function. The Call Handling Function instructs the Switch to set up and tear down connections between specific narrowband channels and AAL2 channels in accordance with information received via the TMF signalling.

The Signalling Interworking function also performs any conversion that may be necessary between the CAS and CCS signalling on the narrowband and ATM sides of the CO-IWF. In networks where Loop Emulation Service is supported by means of SVCs, the Signalling Interworking Function interacts with the VCC Management function to initiate the setup and teardown of SVCs to carry AAL2 bearer traffic.

Individual bearer streams leaving the switch on the ATM side are processed by the SSCS User function. For voice, this comprises a Codec with or without Speech Activity Detection, as indicated by the profile in use on the connection. For facsimile, the SSCS User may comprise a facsimile demodulation/remodulation capability. The resulting SDUs from the SSCS User are passed to an SSCS (either I.366.1 or I.366.2) for AAL2 packetization. The AAL2 packets are then transferred to the AAL2 CPS function for multiplexing into cells for transfer to the ATM function. An inverse set of procedures is followed for information arriving at an IWF in the opposite direction of transmission.

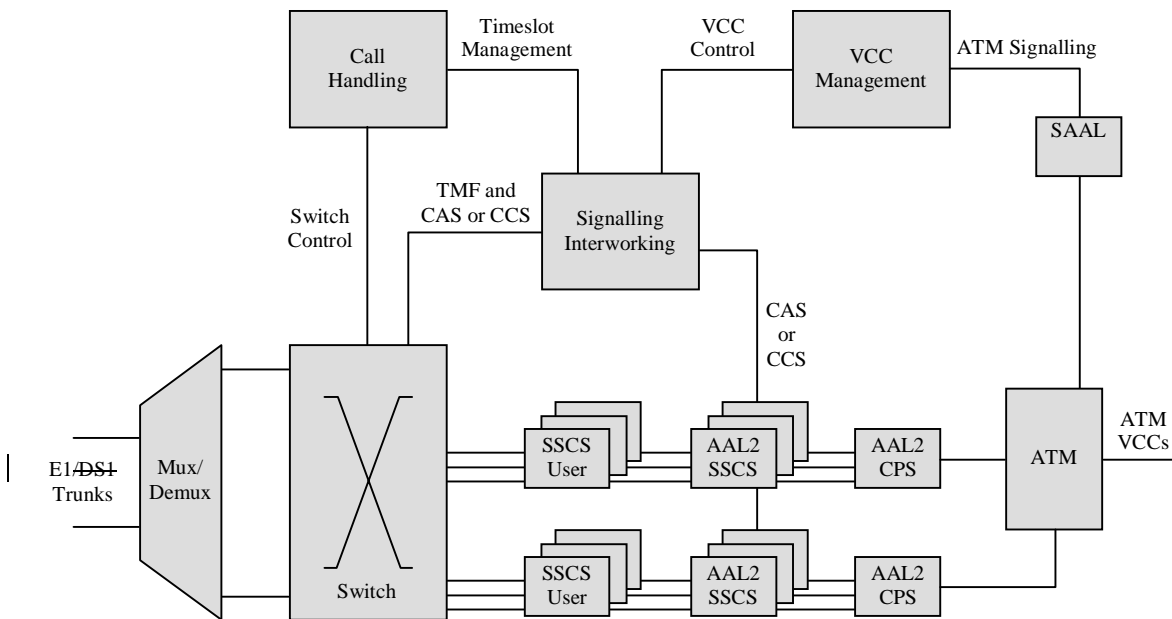

**Figure A-1: Example of functions within a CO-IWF**

## Appendix B

Appendix B 'Operation of GR-303 or TR-008 Service Node Interface at CO-IWF' is not applicable.

## Appendix C

Replace introductory text of appendix C 'Operation of a V5 Service Node Interface at the CO-IWF' by:

This informative appendix describes two kinds of Service Node Interface that are prevalent in markets where European telecoms standards apply, and illustrates interworking functions within the CO-IWF that are appropriate for these Service Node Interfaces. The contents of appendix C shall be considered as normative.

### Appendix C, clause C.1

Replace text in clause 'C.1, The V5 interfaces' by:

The V5 specifications define digital access network interfaces based on European (E1) standards, and were originally specified by the European Telecommunications Standards Institute (ETSI) although these specifications have now been adopted by the ITU. The relevant specification references are:

	<b>ETSI</b>	<b>ITU-T Recommendations</b>
<b>V5.1</b>	ETS 300 324	ITU-T Recommendation G.964
<b>V5.2</b>	ETS 300 347	ITU-T Recommendation G.965

The V5.x interfaces are based on physical links operating at 2 048 kbit/s which are channelized as 32 x 64 kbit/s timeslots. Of these, 2 timeslots are reserved for signalling and other purposes, allowing a maximum of 30 timeslots in each 2 048 kbit/s physical link for bearer traffic.

Both interfaces support access networks that provide any mix of analog POTS and ISDN Basic Rate Access lines. V5.1 is defined as a single 2 048 kbit/s link where bearer channels are permanently assigned either to a specific POTS line or a specific ISDN B-channel from an end user. In other words, V5.1 supports only static timeslot assignment.

V5.2 is a superset of V5.1, and much of the V5.2 specification refers directly to clauses in V5.1. The key differences between V5.1 and V5.2 are as follows:

- V5.2 interfaces comprise between 1 and 16 physical 2 048 kbit/s links.

- Timeslots in the 2 048 kbit/s links are allocated dynamically to end-user POTS lines or ISDN B-channels, usually on a call-by-call basis.
- V5.2 interfaces can support ISDN Primary Rate Access as well as POTS and ISDN Basic Rate.

Since V5.2 is a superset of V5.1, and since the majority of LES applications ~~in markets outside North America~~ will likely be based on V5.2 rather than V5.1 to take advantage of the concentration capabilities offered by dynamic timeslot assignment, this appendix will consider the details of V5.2 first.

#### Appendix C, clause C.2.1

Replace text in clause 'C.2.1 Overview of V5.2' by:

A V5.2 interface connects an "Access Network" (AN) to a "Local Exchange" (LE). ~~These are equivalent to the GR-303 terms RDT (Remote Digital Terminal) and IDT (Integrated Digital Terminal).~~

A V5.2 interface comprises between 1 and 16 physical 2 048 kbit/s links which support both bearer channels and logical "communications channels" which convey signalling and control information over the interface. In general the communications channels occupy timeslot 16 on one or more of the 2 048 kbit/s links. Where the V5.2 interface comprises two or more 2 048 kbit/s links, two of these links are designated respectively the "primary" and the "secondary," and the communications channels are provisioned on timeslot 16 of these two links. A protection protocol is used to switch communications from the primary to the secondary link in the event of the failure of the primary link.

The communications channels supported over the V5.2 interface transport the following protocols between the AN and the LE:

- ISDN D-channel signalling to and from end-user ISDN ports;
- PSTN signalling which conveys supervisory line states to and from end-user analog POTS ports;
- control protocol which is used to block, unblock, activate and de-activate both ISDN and analog POTS user ports;
- Bearer Channel Connection protocol which is used for dynamic assignment of timeslots to both ISDN B-channel and analog POTS user ports;
- protection protocol which is used to support the switchover of communications channels between primary and secondary links in the event of a communications channel failure;
- link control protocol which is used to identify and control the state of the physical 2 048 kbit/s links that make up the V5.2 interface.

These protocols are multiplexed onto the communications channels by means of an encapsulation known as the LAPV5 Envelope Function. The LAPV5-EF uses an Envelope Function Address (EFaddr) to identify the destination process of the encapsulated message. EFaddr values in the range 0-8175 are reserved for ISDN D-channel signalling messages. For these, the value of EFaddr maps to the ISDN end-user port number. EFaddr values in the range 8176-8180 are assigned to the other protocols that operate over the communications channels, including the PSTN protocol, the BCC protocol and the Protection protocol.

The ISDN D-channel protocols are not terminated by the AN. They are forwarded by the AN to the BRA or PRA port on the end-user terminal equipment that is identified by the value of EFaddr. The assignment of EFaddr values to end-user BRA or PRA ports is carried out by provisioning.

All the other protocols that are supported by the communications channels between the AN and the LE are terminated in the AN. Each of these protocols runs over its own Data Link layer using the Link Access Protocol V5 Data Link (LAPV5-DL) which is a subset of the LAP-D protocol defined by Q.921.

### Appendix C, clause C.2.1.3

Replace text in clause 'C.2.1.3, PSTN protocol' by:

The PSTN protocol conveys the supervisory state of all analog POTS end-user lines between the AN and the LE. There is one instance of the PSTN protocol between the AN and the LE, and this handles the supervisory states of all the analog POTS ports defined at the AN. The port with which any given PSTN protocol message is associated is identified by means of a Layer 3 Address in each PSTN protocol message. The L3 Address is effectively the user port number of the analog POTS port, equivalent to a CRV in the GR-303 specification.

The V5 PSTN protocol is described as essentially a "stimulus" protocol, in that it conveys information about analog line state changes in the upstream direction from AN to LE, and requests to change state in the direction from LE to AN.

A call may be initiated from either end with an ESTABLISH message. This is acknowledged by the other end with an ESTABLISH ACK message. If the call is a terminating call (from the network to the user) then the ESTABLISH message may contain information about what ringing cadence is to be used.

The ESTABLISH message effectively seizes the line. Once seized, and until it is released, further supervisory signalling on the line is conveyed in either direction by means of a SIGNAL message, which is acknowledged by the other end with a SIGNAL ACK message. The SIGNAL message may be used to convey in the upstream direction, for example, a switch hook flash (known in V5 as "register recall"), a pulsed dial digit or a return to on-hook. In the downstream direction, the SIGNAL message may be used to convey DDI digits or metering pulses.

The line may be released from either end with a DISCONNECT message, and is acknowledged from the other end by DISCONNECT COMPLETE.

The PSTN protocol as defined in V5.1 and V5.2 is extremely flexible and supports a very wide range of possible operations on an analog line. The actual subset of PSTN protocol messages and information elements that is used in a given implementation of the V5 interface is defined by the "National PSTN" protocol specification which is the responsibility of the local service provider. The V5 specifications give some simple examples of how the PSTN protocol may be used to support telephony services over analog lines, but little detail is provided. It would not be possible to create a useful implementation of V5 support for analog POTS without first obtaining details of the National PSTN protocol that applied to the territory to be served.

### Appendix C, clause C.2.1.4

Replace text in clause 'C.2.1.4, Bearer channel connection protocol' by:

The BCC protocol is used to control the dynamic assignment of timeslots within the 2 048 kbit/s links that make up the V5 interface to end-user bearer channels that may be analog POTS lines or ISDN B-channels.

~~The BCC protocol is somewhat simpler than the TMC protocol used in GR-303. One of the reasons for this is that, unlike GR-303, it is not necessary for the AN to monitor the supervisory signaling on user ports that are not currently assigned to timeslots, as is the case with GR-303. Supervisory signaling from all user ports, regardless of whether they are assigned to timeslots or not, is carried by the PSTN protocol to the LE. The LE monitors this signaling and when it sees an off-hook event on a user port which does not currently have a timeslot assignment, it initiates the timeslot assignment process.~~

It is based on two kinds of message from LE to AN, ALLOCATE and DE-ALLOCATE, and two kinds of responses from the AN to the LE, COMPLETE or REJECT.

ALLOCATE and DE-ALLOCATE messages from LE to AN request the allocation or de-allocation of a given timeslot to a given user bearer channel. Both types of message contain a unique BCC reference number to uniquely identify the request, and this reference number is repeated by the AN in its response message to the LE so that the LE can correlate the response with the request.

The ALLOCATE message specifies the identity of the timeslot (2 048 kbit/s link identity and timeslot number) and the identity of the user port that are to be cross-connected by the AN. The message contains a marker bit indicating whether the user port is an ISDN user port or a POTS user port. If the user port is an ISDN user port, then the ALLOCATE message also indicates which B-channel on the user port is to be cross-connected to the specified timeslot.

If the AN is able to complete the requested allocation, it responds with an ALLOCATION COMPLETE message, specifying only the BCC reference number of the allocation request. If it cannot complete the requested allocation, then it responds with an ALLOCATION REJECT message, specifying the BCC reference number of the allocation request together with a cause code indicating the reason for the rejection.

When the LE wishes to de-allocate the timeslot, exactly the same procedure is followed as for allocation, except that the message send to the AN is DE-ALLOCATION, and the possible response messages from the AN are DE-ALLOCATION COMPLETE or DE-ALLOCATION REJECT.

The BCC protocol also defines an AUDIT message that allows the LE to query the AN for details of timeslot allocation either by identifying a given timeslot or by identifying a given user bearer channel.

Add following new clause in appendix C:

#### **C.4 CO-IWFs supporting V5 with LES CAS**

Although CCS between the IWFs provides a convenient and natural solution for CO-IWF with a V5 SNI, it is not the only solution. The V5 PSTN signalling at the V5 SNI can be mapped to CAS signalling on the ATM side. An example mapping between the PSTN signalling at the V5 SNI and LES CAS signalling is provided in appendix F.

#### **Appendix D**

Appendix D 'Mapping of North American analog signalling to PSTN messages' is not applicable.

#### **Appendix E**

Replace text in appendix E 'Example parameters for CP-IWF configuration' by:

This informative appendix identifies parameters that may have to be configured at the CP-IWF for inter-operation with a CO-IWF, and offers example values for these parameters.



Table E-1: CP-IWF configuration parameters

Parameter Name	Parameter Value
AAL2 Bearer Channel Virtual Circuit	VPI = 0, VCI = 40 <sub>10</sub>
AAL2 ApplD	0 x 0000000A
AAL2 CPS parameter values	
Max CPS-SDU size	45 <sub>10</sub>
Max number of multiplexed channels	112 <sub>10</sub>
CID range for AAL2 user channels	16.127
SSCS parameter values	
SSCS type	I.366.2
Audio Service	Enabled
Circuit Mode Data	Disabled
Frame Mode Data	Disabled
Fax Demodulation/Remodulation	Disabled
CAS (Channel Associated Signalling)	Enabled
DTMF Dialed Digits	Disabled
MF-R1 Dialed Digits	Disabled
MF-R2 Dialed Digits	Disabled
PCM Encoding	Generic PCM encoded as A <sub>#</sub> law
Max length frame mode data	65 535 <sub>10</sub>
Profile source	Other predefined profile
Predefined profile identifier	7
OUI Profile Source	00A03E <sub>16</sub>
Broadband Bearer Capability	
Bearer Class	10 000 <sub>2</sub>
ATM Transfer Capability	0001001 <sub>2</sub>
ATM Traffic Descriptors	
Forward PCR CLP = 0 + 1	Dependent on services offered
Backward PCR CLP = 0 + 1	Dependent on services offered
Forward SCR CLP = 0 + 1	Dependent on services offered
Backward SCR CLP = 0 + 1	Dependent on services offered
Forward MBS CLP = 0 + 1	Dependent on services offered
Backward MBS CLP = 0 + 1	Dependent on services offered

Add following new appendix F:

---

## Appendix F (informative): Example of mapping between LES CAS signalling and V5 PSTN signalling at the SNI

### F.1 Purpose

The purpose of this informative appendix is to illustrate through an example of how CO-IWFs that support V5 at the SNI could interwork with CAS based signalling used between the CP-IWF and the CO-IWF.

The CAS "ABCD" bits that are transported between the CP-IWF and the CO-IWF represent supervisory and address signals that are coded as per national standard or network operator specification (see clause 5.1.1). Thus the example considered in this appendix maps UK V5 PSTN Signalling defined in the UK V5 PSTN Requirements Specification SSPE/SPEC/001-1 to UK CAS signalling defined in BS 7378-3:1998.

---

### F.2 Mapping Details

The mapping details are partitioned into two tables. The first table focuses on the mapping in the direction of CAS signals received from the CP-IWF which are then mapped to the V5 UK PSTN signals sent over the SNI. Whilst the second table describes the reverse mapping in the direction of the SNI to the CP-IWF.

The table identifies the four types of user ports that are supported within the UK and these are:

- DEL - Direct Exchange Line. Used for supporting an ordinary domestic apparatus;
- LCPBX - Loop Calling Private Branch Exchange. Used for supporting an analogue PBX that uses loop start signalling;
- ECPBX - Earth Calling Private Branch Exchange. Used for supporting an analogue PBX that uses earth calling start signalling;
- DDI - Direct Dial In PBX. This represents an analogue DDI PBX and only incoming calls are presented to a user port marked as DDI. Outgoing calls from a DDI PBX are presented on a user port marked as ECPBX or LCPBX.

Table F-1: UK CAS signals to UK V5 PSTN signal mappings

Direction: CP-IWF to SNI				
UK CAS		V5 UK PSTN		Comments
CAS Signal	ABCD bits	V5 Message	User Port Type	
Seize	0 1 0 1	Establish (Steady Signal - Off Hook)	DEL, LCPBX, ECPBX	Indicates that the apparatus wishes to make an outgoing call.
Alternate Break/Make Answer	1 1 0 1 / 0 1 0 1	Signal (Digit Signal)	DEL, LCPBX, ECPBX	Used for reporting loop disconnect digits.
Answer	0 1 0 1	Signal (Steady Signal - Off Hook)	DEL, LCPBX, ECPBX	Indicates that the incoming call has been accepted or the call has been re-answered.
Idle	1 1 0 1	Signal (Steady Signal - On Hook)	DEL, LCPBX, ECPBX	Indicates that the CPE is free to receive incoming calls and requires the network to release the call.
Alternate Break/Make	1 1 0 1 / 0 1 0 1	Signal (Digit Signal = 1) or Signal (Pulsed Signal = Register Recall)	DEL, LCPBX, ECPBX	If the pulse is the of the same duration as a loop disconnect Digit 1, then a V5 digit signal is sent. However, if the pulse duration is longer than digit 1 and shorter than an On-Hook, then a V5 register recall is sent.
Answer	0 1 0 1	Signal (Steady Signal - Reversed Polarity)	DDI	An indication that the called party has answered.
Free	1 1 0 1	Signal (Steady Signal - Normal Polarity)	DDI	Indicates that the DDI PBX is ready to receive incoming calls.
Backward Busy	1 1 1 1	Establish (Steady Signal - No battery)	DDI	Sent whilst there was no call present to indicate that the DDI PBX does not wish to receive calls and should be considered busy.
Backward Busy	1 1 1 1	Signal (Steady Signal - No battery)	DDI	Sent during a call to indicate that the DDI PBX does not wish to receive calls and should be considered busy.

Table F-2: UK V5 PSTN signal to UK CAS signal mappings

Direction: SNI to CP-IWF				
V5 PSTN		UK CAS		Comments
V5 Message	User Port Type	CAS Signal	ABCD bits	
Establish (Cadence Ringing)	DEL, LCPBX, ECPBX	Alternate Ringing On/Off	1 0 1 1 / 1 0 0 1	<b>A signal to indicate that ringing is applied with the specified cadence when a new incoming call is detected.</b>
Signal (Cadence Ringing)	DEL, LCPBX, ECPBX	Alternate Ringing On/Off	1 0 1 1 / 1 0 0 1	A signal sent during a call to indicate the subscriber should be re-rung with the specified cadence.
Establish (Pulsed Signal - Initial Ring)	DEL, LCPBX, ECPBX	Alternate Ringing On/Off	1 0 1 1 / 1 0 0 1	An indication that a single pulse of ringing should be applied. This signal is typically used as a wake up signal for number display purposes or to indicate that an incoming call has been forwarded. (see note)
Signal (Pulsed Signal - Initial Ring)	DEL, LCPBX	Alternate Ringing On/Off	1 0 1 1 / 1 0 0 1	An indication that a single pulse of ringing should be applied. This signal is typically used as a wake up signal for number display purposes or to indicate that an incoming call has been forwarded. (see note)
Establish (Steady Signal - Reversed Polarity)	DEL, LCPBX, ECPBX	Line reversal	0 1 0 1	An indication that reverse polarity line feed should be applied. This signal is typically

Direction: SNI to CP-IWF				
V5 PSTN		UK CAS		Comments
V5 Message	User Port Type	CAS Signal	ABCD bits	
Signal (Steady Signal - Reversed Polarity)	DEL, LCPBX, ECPBX	Called Party Answer	0 1 0 1	used as a wake up signal for number display purposes. An indication to the calling apparatus that the called party has answered the outgoing call.
Signal (Pulsed Signal - pulsed no battery)	DEL, LCPBX, ECPBX	Disconnect Clear	0 0 0 1	Normally indicates that the network has accepted the on-hook and has cleared the call. (see note)
Establish Ack (Pulsed Signal - pulsed no battery)	LCPBX, ECPBX	Disconnect Clear	0 0 0 1	Informs the apparatus that the network has rejected the outgoing call attempt. (see note)
Signal (Pulsed Signal - pulsed reduce battery)	DEL	End of Call	0 0 0 1	Informs the apparatus that the network has cleared the call towards the other party. (see note)
Establish Ack (Pulsed Signal - pulsed reduce battery)	DEL,	End of Call	0 0 0 1	Informs the apparatus that the network has rejected the outgoing call attempt. (see note)
Signal (Pulsed Signal - Meter Pulse)	DEL, LCPBX, ECPBX	Subscriber Meter Pulse	0 1 1 1	A request to generate meter pulses and the number of pulses that are generated is determined by the "number of pulses" field in the V5 message. (see note)
Disconnect	DEL, LCPBX, ECPBX, DDI	Free	1 1 0 1	<b>Used to indicate that the call has finished and that the analogue port should transit into the free state.</b>
Establish (Steady Signal - Off Hook)	DDI	Seize	0 1 0 1	An indication to signal to the DDI PBX the arrival of an incoming call.
Signal (Digit Signal)	DDI	Alternate Break/Make	1 1 0 1/ 0 1 0 1	<b>Used for sending loop disconnect digits to the DDI PBX.</b>
Signal (Pulsed Signal - Pulsed On Hook)	DDI	Idle	1 1 0 1	An indication to the DDI PBX that the call has been cleared by the network.

NOTE: After completion of the pulsed signal the steady signal condition that was present prior to the application of pulsed signal will be reflected in the CAS signal.

---

## History

<b>Document history</b>		
V1.1.1	February 2001	Membership Approval Procedure    MV 20010406: 2001-02-06 to 2001-04-06
V1.1.1	April 2001	Publication