

**Intelligent Network (IN);
Service provider access requirements;
Enhanced telephony services**



Reference

REG/SPAN-141604

Keywords

protocol, telephony, access, UNI, NNI, IN

ETSI

650 Route des Lucioles
F-06921 Sophia Antipolis Cedex - FRANCE

Tel.: +33 4 92 94 42 00 Fax: +33 4 93 65 47 16

Siret N° 348 623 562 00017 - NAF 742 C
Association à but non lucratif enregistrée à la
Sous-Préfecture de Grasse (06) N° 7803/88

Important notice

Individual copies of the present document can be downloaded from:

<http://www.etsi.org>

The present document may be made available in more than one electronic version or in print. In any case of existing or perceived difference in contents between such versions, the reference version is the Portable Document Format (PDF). In case of dispute, the reference shall be the printing on ETSI printers of the PDF version kept on a specific network drive within ETSI Secretariat.

Users of the present document should be aware that the document may be subject to revision or change of status. Information on the current status of this and other ETSI documents is available at <http://www.etsi.org/tb/status/>

If you find errors in the present document, send your comment to:
editor@etsi.fr

Copyright Notification

No part may be reproduced except as authorized by written permission.
The copyright and the foregoing restriction extend to reproduction in all media.

© European Telecommunications Standards Institute 2000.
All rights reserved.

Contents

Intellectual Property Rights	8
Foreword.....	8
1 Scope	9
2 References	9
3 Definitions and abbreviations.....	10
3.1 Definitions	10
3.2 Abbreviations	11
4 Introduction	12
4.1 Current situation	12
4.2 Regulatory aspects.....	13
4.3 Security aspects	14
4.4 Service interaction aspects	14
4.5 Charging aspects	15
4.6 Guidelines for the service provider access requirements.....	15
5 Functional requirements for service provider access	15
5.1 Framework and overall list of the requirements	15
5.2 Calling party information handling capabilities	16
5.2.1 Reception of the calling line identity	16
5.2.2 Presentation of the complete CLI information to the PTN	16
5.2.3 Addition or substitution of a calling line identity	17
5.2.4 Provision of CLI information to an SP-initiated call	17
5.2.5 Relaying of the malicious call identification data of a received call.....	17
5.3 Basic call set-up and clear-down capabilities.....	17
5.3.1 Return speech path connection from the terminating PTN to the calling party	17
5.3.2 Routing of an originating or incoming call from the PTN to the SP.....	17
5.3.3 Indication of an originating or incoming call from the PTN to the SP	17
5.3.4 Routing of a terminating call from the PTN to the SP.....	17
5.3.5 Indication of a terminating call from the PTN to the SP.....	17
5.3.6 Reception of an indication of the cause of an unsuccessful call	18
5.3.7 Provision of information for the destination and routing of a call	18
5.3.8 Call drop-back	18
5.3.9 User interaction without service charging of the end user	18
5.3.10 Reception of the originally dialled digits	18
5.3.11 Disconnection of a call in progress	18
5.3.12 Connection of a call to an interactive voice response unit in the PTN	18
5.3.13 Alternate routing of a call or the indication of a call to another "point of presence" of the SP	18
5.4 Supplementary call and data processing capabilities.....	19
5.4.1 Interrogation of a network termination point for data delivery.....	19
5.4.2 Overriding of the "incoming call barring" supplementary service.....	19
5.4.3 Bypassing of the "call diversion" supplementary service	19
5.4.4 Message waiting indication	19
5.5 Charging-related capabilities.....	19
5.5.1 Changes in the charging rate of a call	19
5.6 Traffic-related capabilities.....	19
5.6.1 Event traceability	19
5.6.2 Traffic control capabilities.....	19
5.6.3 Avoidance of the cyclical routing of a call	20
6 Circuit-related functional requirements.....	20
6.1 Call connection scenarios	20
6.2 Calling party information handling capabilities	21
6.2.1 Reception of the calling line identity	21
6.2.1.1 Priority	21
6.2.1.2 Example of usage	21

6.2.1.3	Technical aspects	21
6.2.1.4	Information flow chart	22
6.2.2	Presentation of the complete CLI information to the PTN	22
6.2.2.1	Priority	22
6.2.2.2	Example of usage	22
6.2.2.3	Technical aspects	22
6.2.2.4	Information flow chart	23
6.2.3	Addition or substitution of a calling line identity	23
6.2.3.1	Priority	23
6.2.3.2	Example of usage	23
6.2.3.3	Technical aspects	23
6.2.3.4	Information flow chart	24
6.2.4	Provision of CLI information to an SP-initiated call	24
6.2.4.1	Priority	24
6.2.4.2	Example of usage	24
6.2.4.3	Technical aspects	24
6.2.4.4	Information flow chart	24
6.2.5	Relaying of the malicious call identification data of a received call.....	25
6.2.5.1	Priority	25
6.2.5.2	Example of usage	25
6.2.5.3	Technical aspects	25
6.2.5.4	Information flow chart	25
6.3	Basic call set-up and clear-down capabilities	27
6.3.1	Return speech path connection from the terminating PTN to the calling party	27
6.3.1.1	Priority	27
6.3.1.2	Example of usage	27
6.3.1.3	Technical aspects	27
6.3.1.4	Information flow chart	27
6.3.2	Routing of an originating or incoming call from the PTN to the SP.....	27
6.3.2.1	Priority	28
6.3.2.2	Example of usage	28
6.3.2.3	Technical aspects	28
6.3.2.4	Information flow chart	28
6.3.3	Indication of an originating or incoming call from the PTN to the SP	29
6.3.4	Routing of a terminating call from the PTN to the SP	29
6.3.4.1	Priority	29
6.3.4.2	Example of usage	29
6.3.4.3	Technical aspects	29
6.3.4.4	Information flow chart	30
6.3.5	Indication of a terminating call from the PTN to the SP.....	30
6.3.6	Reception of an indication of the cause of an unsuccessful call	31
6.3.6.1	Priority	31
6.3.6.2	Example of usage	31
6.3.6.3	Technical aspects	31
6.3.6.4	Information flow chart	31
6.3.7	Provision of information for the destination and routing of a call	32
6.3.7.1	Priority	32
6.3.7.2	Example of usage	32
6.3.7.3	Technical aspects	32
6.3.7.4	Information flow chart	32
6.3.8	Call drop-back	33
6.3.8.1	Priority	33
6.3.8.2	Example of usage	33
6.3.8.3	Technical aspects	33
6.3.8.4	Information flow chart	33
6.3.9	User interaction without service charging of the end user	33
6.3.9.1	Priority	33
6.3.9.2	Example of usage	33
6.3.9.3	Technical aspects	34
6.3.9.4	Information flow chart	34
6.3.10	Reception of the originally dialled digits	34
6.3.10.1	Priority	34

6.3.10.2	Example of usage	34
6.3.10.3	Technical aspects	34
6.3.10.4	Information flow chart	35
6.3.11	Disconnection of a call in progress	35
6.3.11.1	Priority	36
6.3.11.2	Example of usage	36
6.3.11.3	Technical aspects	36
6.3.11.4	Information flow chart	36
6.3.12	Connection of a call to an interactive voice response unit in the PTN	36
6.3.13	Alternate routing of a call or the indication of a call to another "point of presence" of the SP	36
6.3.13.1	Priority	36
6.3.13.2	Example of usage	37
6.3.13.3	Technical aspects	37
6.3.13.4	Information flow chart	37
6.4	Supplementary call and data processing capabilities.....	37
6.4.1	Interrogation of a network termination point for data delivery.....	37
6.4.1.1	Priority	37
6.4.1.2	Example of usage	37
6.4.1.3	Technical aspects	37
6.4.1.4	Information flow chart	38
6.4.2	Overriding of the "incoming call barring" supplementary service.....	38
6.4.2.1	Priority	38
6.4.2.2	Example of usage	38
6.4.2.3	Technical aspects	38
6.4.2.4	Information flow chart	38
6.4.3	Bypassing of the "call diversion" supplementary service	39
6.4.3.1	Priority	39
6.4.3.2	Example of usage	39
6.4.3.3	Technical aspects	39
6.4.3.4	Information flow chart	39
6.4.4	Message waiting indication	40
6.4.4.1	Priority	40
6.4.4.2	Example of usage	40
6.4.4.3	Technical aspects	40
6.4.4.4	Information flow chart	40
6.5	Charging-related capabilities.....	41
6.5.1	Changes in the charging rate of a call	41
6.5.1.1	Priority	41
6.5.1.2	Example of usage	41
6.5.1.3	Technical aspects	41
6.5.1.4	Information flow chart	41
6.6	Traffic-related capabilities.....	42
6.6.1	Event traceability	42
6.6.1.1	Priority	42
6.6.1.2	Example of usage	42
6.6.1.3	Technical aspects	42
6.6.1.4	Information flow chart	43
6.6.2	Traffic control capabilities.....	43
6.6.2.1	Priority	43
6.6.2.2	Example of usage	43
6.6.2.3	Technical aspects	43
6.6.2.4	Information flow chart	43
6.6.3	Avoidance of the cyclical routing of a call	44
6.6.3.1	Priority	44
6.6.3.2	Example of usage	44
6.6.3.3	Technical aspects	44
6.6.3.4	Information flow chart	44
7	Non-circuit-related functional requirements	45
7.1	Call connection scenarios	45
7.2	Calling party information handling capabilities	46
7.2.1	Reception of the calling line identity	46

7.2.1.1	Priority	46
7.2.1.2	Example of usage	46
7.2.1.3	Technical aspects	46
7.2.1.4	Information flow chart	47
7.2.2	Presentation of the complete CLI information to the PTN	47
7.2.2.1	Priority	47
7.2.2.2	Example of usage	47
7.2.2.3	Technical aspects	47
7.2.2.4	Information flow chart	47
7.2.3	Addition or substitution of a calling line identity	48
7.2.3.1	Priority	48
7.2.3.2	Example of usage	48
7.2.3.3	Technical aspects	48
7.2.3.4	Information flow chart	48
7.2.4	Provision of CLI information to an SP-initiated call	49
7.2.4.1	Priority	49
7.2.4.2	Example of usage	49
7.2.4.3	Technical aspects	49
7.2.4.4	Information flow chart	49
7.2.5	Relaying of the malicious call identification data of a received call.....	50
7.3	Basic call set-up and clear-down capabilities	50
7.3.1	Return speech path connection from the terminating PTN to the calling party	50
7.3.1.1	Priority	50
7.3.1.2	Example of usage	50
7.3.1.3	Technical aspects	50
7.3.1.4	Information flow chart	50
7.3.2	Routing of an originating or incoming call from the PTN to the SP.....	51
7.3.3	Indication of an originating or incoming call from the PTN to the SP	51
7.3.3.1	Priority	51
7.3.3.2	Example of usage	51
7.3.3.3	Technical aspects	51
7.3.3.4	Information flow chart	52
7.3.4	Routing of a terminating call from the PTN to the SP	52
7.3.5	Indication of a terminating call from the PTN to the SP.....	52
7.3.5.1	Priority	52
7.3.5.2	Example of usage	52
7.3.5.3	Technical aspects	53
7.3.5.4	Information flow chart	53
7.3.6	Reception of an indication of the cause of an unsuccessful call	53
7.3.6.1	Priority	54
7.3.6.2	Example of usage	54
7.3.6.3	Technical aspects	54
7.3.6.4	Information flow chart	54
7.3.7	Provision of information for the destination and routing of a call	54
7.3.7.1	Priority	54
7.3.7.2	Example of usage	54
7.3.7.3	Technical aspects	55
7.3.7.4	Information flow chart	55
7.3.8	Call drop-back	55
7.3.9	User interaction without service charging of the end user	55
7.3.10	Reception of the originally dialled digits	55
7.3.10.1	Priority	55
7.3.10.2	Example of usage	55
7.3.10.3	Technical aspects	55
7.3.10.4	Information flow chart	55
7.3.11	Disconnection of a call in progress	56
7.3.11.1	Priority	56
7.3.11.2	Example of usage	56
7.3.11.3	Technical aspects	57
7.3.11.4	Information flow chart	57
7.3.12	Connection of a call to an interactive voice response unit in the PTN	57
7.3.12.1	Priority	57

7.3.12.2	Example of usage	57
7.3.12.3	Technical aspects	57
7.3.12.4	Information flow chart	57
7.3.13	Alternate routing of a call or the indication of a call to another "point of presence" of the SP	58
7.3.13.1	Priority	58
7.3.13.2	Example of usage	58
7.3.13.3	Technical aspects	58
7.3.13.4	Information flow chart	58
7.4	Supplementary call and data processing capabilities.....	59
7.4.1	Interrogation of a network termination point for data delivery.....	59
7.4.1.1	Priority	59
7.4.1.2	Example of usage	59
7.4.1.3	Technical aspects	59
7.4.1.4	Information flow chart	59
7.4.2	Overriding of the "incoming call barring" supplementary service.....	60
7.4.2.1	Priority	60
7.4.2.2	Example of usage	60
7.4.2.3	Technical aspects	60
7.4.2.4	Information flow chart	60
7.4.3	Bypassing of the "call diversion" supplementary service	61
7.4.3.1	Priority	61
7.4.3.2	Example of usage	61
7.4.3.3	Technical aspects	61
7.4.3.4	Information flow chart	61
7.4.4	Message waiting indication	61
7.4.4.1	Priority	61
7.4.4.2	Example of usage	61
7.4.4.3	Technical aspects	61
7.4.4.4	Information flow chart	62
7.5	Charging-related capabilities.....	62
7.5.1	Changes in the charging rate of a call.....	62
7.5.1.1	Priority	62
7.5.1.2	Example of usage	62
7.5.1.3	Technical aspects	62
7.5.1.4	Information flow chart	62
7.6	Traffic-related capabilities.....	63
7.6.1	Event traceability	63
7.6.1.1	Priority	63
7.6.1.2	Example of usage	63
7.6.1.3	Technical aspects	63
7.6.1.4	Information flow chart	63
7.6.2	Traffic control capabilities.....	64
7.6.2.1	Priority	64
7.6.2.2	Example of usage	64
7.6.2.3	Technical aspects	64
7.6.2.4	Information flow chart	64
7.6.3	Avoidance of the cyclical routing of a call	64
8	Architectural view of the service provider access.....	64
8.1	Introduction	64
8.2	Network configuration scenarios.....	65
8.3	SPAI guidelines.....	66
8.4	Service providers' interface scenarios	66
8.5	Functional framework of the SPA on the network level	67
Annex A (informative): Bibliography.....		69
History		70

Intellectual Property Rights

IPRs essential or potentially essential to the present document may have been declared to ETSI. The information pertaining to these essential IPRs, if any, is publicly available for **ETSI members and non-members**, and can be found in ETSI SR 000 314: *"Intellectual Property Rights (IPRs); Essential, or potentially Essential, IPRs notified to ETSI in respect of ETSI standards"*, which is available from the ETSI Secretariat. Latest updates are available on the ETSI Web server (<http://www.etsi.org/ipr>).

Pursuant to the ETSI IPR Policy, no investigation, including IPR searches, has been carried out by ETSI. No guarantee can be given as to the existence of other IPRs not referenced in ETSI SR 000 314 (or the updates on the ETSI Web server) which are, or may be, or may become, essential to the present document.

Foreword

This ETSI Guide (EG) has been produced by ETSI Technical Committee Services and Protocols for Advanced Networks (SPAN), and is now submitted for the ETSI standards Membership Approval Procedure.

1 Scope

The present document lists the first set of access requirements that Service Providers (SPs) have in delivering services over one or more Public Telecommunications Networks (PTNs), primarily fixed PTNs, e.g. Public Switched Telecommunications Networks (PSTNs) and Integrated Services Digital Networks (ISDNs). These requirements are intended to facilitate a non-discriminatory access to the PTNs. The present document does not fully take into account the network integrity, security, charging, and other related aspects from a PTNO's perspective. These aspects are defined in EG 201 807 [4]. The present document and EG 201 807 [4], should not be considered separately for implementation.

The scope of the present document is to present generic functional requirements regarding the Service Provider Access (SPA). The priority of each requirement is based on the need perceived from the SP's viewpoint. Service interaction aspects are outside the scope of the present document.

To fulfil these requirements, appropriate protocols may have to be enhanced or developed based on information flows and taking into account network integrity considerations expressed in the present document.

Clause 4 contains introductory text describing the background and motivations of the requirements of a SPA. Clause 5 contains a summary of requirements regarding the Service Provider Access Interface (SPAI) and a framework that helps the reader to get an overview. Clause 6 contains a description of the requirements concerning the Circuit-Related (CR) aspects of the SPAI, and clause 7 contains the requirements regarding the non-circuit-related (NCR) aspects. Clause 8 contains information on the architectural view of the SP access.

The present document relates to the role of the SP and the role of the Public Telecommunications Network Operator (PTNO), with the realization that market players may act in multiple roles. This is in alignment with the current European legislation, which specifies that all capabilities utilized by a Significant Market Power (SMP) network operator's internal service provisional body, shall also be offered on equal terms to external entities.

2 References

The following documents contain provisions which, through reference in this text, constitute provisions of the present document.

- References are either specific (identified by date of publication, edition number, version number, etc.) or non-specific.
- For a specific reference, subsequent revisions do not apply.
- For a non-specific reference, the latest version applies.

- [1] ETSI ETR 322: "Intelligent network (IN); Vocabulary of terms and abbreviations for CS-1 and CS-2".
- [2] ETSI ETS 300 089 (1992): "Integrated Services Digital Network (ISDN); Calling Line Identification Presentation (CLIP) supplementary service; Service description".
- [3] ETSI ETR 339 (1997): "Intelligent Network (IN); IN interconnect business requirements".
- [4] EG 201 807: "Network Aspects (NA); Network intelligence; Network Operators' requirements for the delivery of Service Provider Access".
- [5] ETSI TR 101 365: "Intelligent Network (IN); IN interconnect threat analysis".
- [6] ETSI TR 101 664: "Intelligent Network (IN); IN interconnect security features".
- [7] ETSI ETS 300 128 (1992): "Integrated Services Digital Network (ISDN); Malicious Call Identification (MCID) supplementary service; Service description".
- [8] ETSI ETS 300 200 (1994): "Integrated Services Digital Network (ISDN); Call Forwarding Unconditional (CFU) supplementary service; Service description".

- [9] Directive 98/10/EC of the European Parliament and Council of 26 February 1998 on the application of Open Network Provisions to voice telephony and on universal service for telecommunications in a competitive environment.
- [10] Directive 97/33/EC of the European Parliament and Council of 30 June 1997 on interconnection in telecommunications with regard to ensuring universal service and interoperability through the application of Open Network Provisions.
- [11] CEPT/ECTRA Recommendation on a Set of Guidelines on Responsibilities for ensuring maintenance of Network Integrity (NI) in an interconnected environment, Rec(98)01, 12th of March 1998.
- [12] CEPT/ECTRA Recommendation on the use of Special Network Access, Rec(99)01, 3rd of March 1999.
- [13] Directive 97/66/EC of the European Parliament and Council on the processing of personal data and the protection of privacy in the telecommunications sector.
- [14] ETSI ETS 300 090 (1992): "Integrated Services Digital Network (ISDN); Calling Line Identification Restriction (CLIR) supplementary service; Service description".
- [15] ETSI ETS 300 335: "Integrated Services Digital Network (ISDN); Signalling System No.7; ISDN User Part (ISUP) version 1; Test specification".
- [16] ITU-T Recommendation Q.1200: "General series Intelligent Network Recommendation structure".

3 Definitions and abbreviations

3.1 Definitions

For the purpose of the present document, the following terms and definitions apply:

calling line identity: number that uniquely identifies a subscriber line that is used for a call

circuit-related interface: signalling connection between a public telecommunications network operator and a service provider, with the extension of the call connection from the public telecommunications network to the service provider's equipment

end user: see "service user" definition

network-network interface: interface at a network node which is used to interconnect the node with another network node

network-provided calling line identity: that is provided by the originating public telecommunications network to a call setup request, if the calling party has not provided any calling line identity or the user-provided calling line identity has not passed a verification in the network [15]

non-call-related: call-unrelated

non-circuit-related interface: control connection between a public telecommunications network operator and a service provider, without the extension of the call connection from the public telecommunications network to the service provider's equipment

presentation-restricted calling line identity: calling line identity that is associated with a marking informing the terminating local exchange not to display this calling line identity to the called party [14]

public telecommunications network: telecommunications network which provides telecommunications services to the general public [1]

public telecommunications network operator: entity which is responsible for the development, provisioning and maintenance of telecommunications services to the general public and for operating the corresponding networks [1]

public telecommunications network originating: pTN to which either the originating line is directly connected or in which an incoming call initiates a service

public telecommunications network terminating: pTN to which either the terminating line is directly connected or in which the terminating line's user profile is stored

service: that which is offered by an administration or recognized private operating agency (i.e. a public or private service provider) to its customers in order to satisfy a telecommunication requirement [1]

service provider: entity which provides services to its service subscribers on a contractual basis and who is responsible for the services offered. The same organization may act as a public telecommunications network operator and a service provider [1]

service provider access: access facility that enables a service provider to access specific functionality of a public telecommunications network.

service provider access interface: interface between a public telecommunications network and a service provider's equipment for enabling the service provider to access specific functionality of a public telecommunications network

service provider access requirement: requirement for access by a service provider to specific functionality of a public telecommunications network

service provider originating: service provider that provides either services relating to the originating line (or to the originating profile), or services acting on the information coming from the originating or incoming call

service provider terminating: service provider that provides either services relating to the terminating line (or to the terminating profile), or services acting on the call-related information coming from the terminating party's line

service subscriber: entity that contracts for services offered by service providers [1]

service user: entity external to the network that uses the services offered by the PTNO or SP

significant market power network operator: see [9]

special network access: access at network termination points other than the more commonly provided network termination points, such as the conventional user-network interfaces. See Article 16 of [9]

user-network interface: interface between the terminal equipment and a network termination point at which the access protocols apply

user-provided calling line identity: network number that has been provided by the calling party [15]

user-provided, not screened calling line identity: network number that has been provided by the calling party and has been passed forward by the originating public telecommunications network without performing any screening function for verification purposes [15]

user-provided, verified and passed calling line identity: network number that has been provided by the calling party and has been successfully verified in the originating public telecommunications network [15]

3.2 Abbreviations

For the purposes of the present document, the following abbreviations apply:

CAMEL	Customized Applications for Mobile Networks Enhanced Logic
CdPy	Called Party
CFU	Call Forwarding Unconditional
CgPy	Calling Party
CLI	Calling Line Identity
CLIP	Calling Line Identification Presentation

CLIR	Calling Line Identification Restriction
CP	Control Plane
CPE	Customer Premises Equipment
CR	Circuit-Related
CS-n	Capability Set n
DSS1	Digital Signalling System 1
EC	European Community
IN	Intelligent Network
INAP	Intelligent Network Application Part
IP	Internet Protocol
ISDN	Integrated Services Digital Network
ISUP	ISDN User Part
ITU-T	International Telecommunications Union - Telecommunication standardization sector
IVR	Interactive Voice Response
LI	Lawful Interception
MAP	Mobile Application Part
MCID	Malicious Call IDentification
MP	Management Plane
NCR	Non-Circuit-Related
NNI	Network-Network Interface
NRA	National Regulatory Authority
NTP	Network Termination Point
PSTN	Public Switched Telephone Network
PTN	Public Telecommunications Network
PTNO	Public Telecommunications Network Operator
PTNorig	originating Public Telecommunications Network
PTNterm	terminating Public Telecommunications Network
PTNtran	transit Public Telecommunications Network
SCP	Service Control Point
SMP	Significant Market Power
SNA	Special Network Access
SP	Service Provider
SPA	Service Provider Access
SPAI	Service Provider Access Interface
SPorig	Service Provider originating
SPterm	Service Provider terminating
SSP	Service Switching Point
TCP	Transmission Control Protocol
UNI	User-Network Interface

4 Introduction

4.1 Current situation

Different types of network control (or signalling) interfaces exist within a public telecommunications network (PTN), between PTNs and for those accessing the PTNs.

There are provisions in two of the open network provisions directives of the European Commission [9] and [10] that provide a regulatory framework for organizations delivering publicly available telecommunications services to request a non-discriminatory access to the networks of those public telecommunications network operator (PTNOs) which have been determined as having "significant market power" (SMP).

Therefore, in order to enable (SPs to deliver services by utilizing the network functionality of one or more PTNs, a specific SPAI may become necessary.

Although there is current work going on within the Internet Engineering Task Force and the Parlay Group that may be relevant; apart from enhancing the basic integrated services digital network (ISDN) access, i.e. DSS1, there are no standardized interfaces available between the SP and the PTNO domains to enable SPA requirements to be satisfied.

The present document defines the first set of service providers' access requirements. The existing network-to-network interfaces (NNI) and user-to-network interfaces (UNI) do not, without enhancement, have the necessary functionality to meet the SPA requirements. Moreover, the existing IN interfaces defined within the ETSI and ITU-T as part of INAP CS-1 were designed primarily for intra-network use with IN CS-2 offering an initial inter-network IN control relationship, neither were specifically designed to meet the requirements of an "open" access interface or to incorporate features that ensure network access integrity and security.

It is seen, therefore, as desirable to develop standardized interfaces to meet the SPA requirements that include features to ensure network integrity and security. There may also be a need to consider service feature interaction. These standardized interfaces are referred to, in the present document, as SPAI.

It will be seen that the SPA requirements fall into circuit-related (CR) and non-circuit-related (NCR) categories, hence development of the SPAI could use the existing CR and NCR interfaces as a basis, or alternatively, entirely new interfaces could be developed.

4.2 Regulatory aspects

Special network access (SNA) is a regulatory provision specified in Article 16 of [9]. The SNA concept has been introduced to enable those organizations providing telecommunications services to gain access to the public telecommunication networks of SMP organizations, at network termination points (NTPs) other than the more commonly provided NTPs such as the typical range of user-network interfaces for the PSTN and ISDN.

The SNA may be facilitated via technical interfaces between SP organizations requesting such access and those organizations which are obligated under the directives to respond to requests for its provision.

The Voice Telephony directive [9] requires that SMP organizations offering the SNA should follow the principle of non-discrimination. This means that SMP organizations shall provide SNA facilities to requesting organizations under the same conditions and the same quality that they provide for their own services or subsidiaries.

This implies that under the Voice Telephony directive [9] SPs could expect to receive network functions or capabilities on the same terms and conditions as what SMP organizations offer to their own service subsidiary. It will be a matter for national regulatory authorities (NRAs) to decide what capabilities can be reasonably made available via the SNA, should there be commercial disputes.

The specification of the SPA requirements and the resulting interfaces should be guided by the work done by the European Committee for Telecommunications Regulatory Affairs (ECTRA) and the European Telecommunications Platform (ETP) on both network integrity and the special network access as introduced in the relevant EC directives [12].

All the requirements that are related to the usage and delivery of the calling line identity (CLI) shall be in accordance with the legal and regulatory provisions in each country, as well as the general provision of the European directive of privacy and data protection [13].

The technical requirements of legal interception (see ES 201 158 in Annex A) and [13] will need to accord with the specific national regulations on security and interception that are in force in the respective countries.

SPs wishing to operate in one or more countries will need to comply with the specific regulatory requirements of the different NRAs. This may entail some kind of authorization or other rules which are applicable in various countries. Such rules may include the procedures by which the SPs are allocated numbers for their specific services. The requirements of national licensing or authorizations is however outside the scope of the present document.

4.3 Security aspects

End users, SPs and PTNOs have a range of different business objectives and requirements regarding the provision of telecommunication services over PTNs. A number of those objectives have been identified [3]. In order to meet them, security aspects need to be carefully considered in a new environment with a multitude of interconnections and access configurations for SPs.

From the viewpoint of the end users, the key requirements are:

- availability of the services;
- correct billing;
- fraud protection;
- confidentiality; and
- privacy.

From the viewpoint of the SPs and PTNOs, the key requirements are:

- availability of the network, services, and maintenance;
- correct charging;
- capability of tracing individual calls;
- protection of subscriber-related data against intruders; and
- elimination of fraudulent use of the equipment of the PTNOs and SPs.

Security violations may have a significant negative business impact for both SPs and NOs, e.g. loss of income, reputation and market share.

In particular, network integrity is a key issue when inter-network relationships are established between PTNOs and SPs. In the connection of the SPA, a basic set of facilities may be needed to secure the interfaces between the PTNOs and SPs [6] and [11]. A threat analysis of IN-based interconnections is presented in TR 101 365 [5], and some guidelines on the relevant security measures are given in TR 101 664 [6].

Screening and mapping functions are used to control and secure bilateral agreements on the interfaces between the PTNs. Today, the PTNOs have screening and mapping facilities on some of the inter-connecting NNIs, such as the ISUP connections. These facilities and functions need to be gradually extended to cover all of the interfaces between the PTNOs and SPs.

4.4 Service interaction aspects

In an environment where an end user subscribes to a range of services from more than one provider, adverse interactions may occur between services and service features. This implies the need for additional functionality to manage the interaction aspects to enable integrated and coherent service delivery.

Further study is needed for service interaction aspects, including the adverse interactions that may occur between the PTNO's and SP's equipment, when more than one of the parties involved in the call handling requires to be able to control the call.

A major example of such service interaction issues is provided by the combination of number portability and service providers access requirements. For instance, several requirements state that an SP-related action may be triggered on the basis of a call with the calling party's CLI in a specific numbering range. Due to the service portability mechanisms, the detection of such numbering range is not a guarantee that the call will have to be processed by the SP to which the numbering range was initially allocated.

4.5 Charging aspects

The standard charging mechanisms allow the charging of a successful call, i.e. between the called party's answer and the release of the call. Some requirements from the SPs imply the usage of the PTNO's network outside this standard case, and the implementation of a related charging mechanism between the PTNO and the SP is therefore necessary, in order to cover such a usage. This is true e.g. in the case of the following requirements of the SPs:

- requesting the PTN to open a backward in-band message path to the calling party immediately upon the arrival of a confirmation of the call set-up, without returning an "answer" signal;
- conveying the indication of an unsuccessful call from the terminating PTN, i.e. either when an indication other than "ringing" is returned to the calling party, or when a "no reply" situation occurs;
- providing call destination and routing information for controlling the destination and routing of the call;
- interacting with the service user before any service charging begins;
- sending data to and receiving data from the SP's NTP without an alerting signal, such as "ringing";
- call charging and billing aspects, as seen from the PTNO's perspective, are considered in EG 201 807 [4].

In the case where end user charging is suspended, delayed, altered or in other ways different from standard call charging mechanisms, the appropriate events has to be created for possible logging e.g. thus providing the necessary data for appropriate accounting between the SP and PTNO.

4.6 Guidelines for the service provider access requirements

In the specification of the SP access requirements, the following aspects need to be taken into consideration.

- The definition of the SPA requirements needs to be based upon service capability requirements from the viewpoint of the SPs and the related requirements of PTNOs, e.g. on service interoperability, network integrity and security.
- The SP shall not have the ability to override PTN restrictions which are due either to national regulations or to high-level network restrictions and barrings.
- The SPA is not required to guarantee that service requests or responses can be passed across the boundaries of different PTNs, especially between different countries.

5 Functional requirements for service provider access

5.1 Framework and overall list of the requirements

SPs have requirements for accessing functionality of a PTN. Access to this functionality is necessary to meet specific service requirements that are not supported by the existing access interfaces. A variety of different services are expected to be offered by SPs to end users. Some of the services will be available to the service subscribers of the SPs only.

The provision of some services requires that the call connection is extended from the PTN to the SP's equipment. In this case, a circuit-related connection (CR) is established between the PTNO and the SP, and a number of requirements can be identified regarding the CR aspects of the SPA.

On the other hand, the provision of some other services requires only a control connection between the PTNO and the SP, called a non-circuit-related (NCR) connection, without extending the call connection from the PTN to the SP's equipment. A number of SPA requirements can be identified regarding the NCR aspects of the SPA.

In this clause, high-level descriptions of both CR and NCR requirements of the SPA are given. A list of the requirements is presented and summarized in table 1. The priority and applicability of each requirement for the CR and NCR case is indicated in the two columns of this table. In clause 6 and 7, the CR and NCR requirements, respectively, are described in more detail.

Table 1: The priorities and application scope of the requirements from the SP's viewpoint

	Requirement	CR	NCR
Calling party information handling capabilities			
5.2.1	Reception of the calling line identity	high	high
5.2.2	Presentation of the complete CLI information to the PTN	high	high
5.2.3	Addition or substitution of a calling line identity	high	high
5.2.4	Provision of CLI information to an SP-initiated call	high	high
5.2.5	Relaying of the malicious call identification data of a received call	high	void
Basic call set-up and clear-down capabilities			
5.3.1	Return speech path connection from the terminating PTN to the calling party	high	high
5.3.2	Routing of an originating or incoming call from the PTN to the SP	high	void
5.3.3	Indication of an originating or incoming call from the PTN to the SP	void	high
5.3.4	Routing of a terminating call from the PTN to the SP	high	void
5.3.5	Indication of a terminating call from the PTN to the SP	void	high
5.3.6	Reception of a indication of the cause of an unsuccessful call	high	high
5.3.7	Provision of information for the destination and routing of a call	high	high
5.3.8	Call drop-back	medium	void
5.3.9	User interaction without service charging of the end user	medium	void
5.3.10	Reception of the originally dialled digits	low	low
5.3.11	Disconnection of a call in progress	medium	medium
5.3.12	Connection of a call to an interactive voice response unit in the PTN	void	medium
5.3.13	Alternate routing of a call or the indications of calls to another "point of presence" of the SP	medium	medium
Supplementary call and data processing capabilities			
5.4.1	Interrogation of a network termination point for data delivery	medium	medium
5.4.2	Overriding of the "incoming call barring" supplementary service	high	high
5.4.3	Bypassing of the "call diversion" supplementary service	low	low
5.4.4	Message waiting indication	high	high
Charging-related capabilities			
5.5.1	Changes in the charging rate of a call	high	high
Traffic-related capabilities			
5.6.1	Event traceability	medium	medium
5.6.2	Traffic control capabilities	medium	medium
5.6.3	Avoidance of the cyclical routing of a call	medium	void

5.2 Calling party information handling capabilities

The implementation of the SP functional requirements relating to the CLI should be in conformance with the general EC and national regulations and with bilateral agreements where they exist, as per clauses 4.2 and 4.6.

5.2.1 Reception of the calling line identity

The SP needs to receive the calling line identity (CLI) from the PTN with a call or call indication, if the CLI is available in the PTN. If the calling party is using the services of the SP and national regulations and/or legislation allows it, this requirement also applies to a CLI marked as "presentation-restricted". All the indicators associated with the CLI need also to be delivered.

This is a CR and NCR requirement.

5.2.2 Presentation of the complete CLI information to the PTN

The SP needs the ability to present all the CLI information about the calling party to the PTN. This includes the original CLI together with the related status information, as well as all the relevant indicators of the category of the call.

This is a CR and NCR requirement.

5.2.3 Addition or substitution of a calling line identity

The SP needs the ability to add or substitute the User Provided CLI to the CLI information of a call when passing it forward.

This is a CR and NCR requirement.

5.2.4 Provision of CLI information to an SP-initiated call

The SP needs the ability to provide CLI information to an SP-initiated call.

This is a CR and NCR requirement.

5.2.5 Relaying of the malicious call identification data of a received call

The SP needs the ability to relay all the received call-specific information unchanged to the terminating network, that may be used for malicious call tracing.

This is a CR requirement.

5.3 Basic call set-up and clear-down capabilities

5.3.1 Return speech path connection from the terminating PTN to the calling party

The SP needs the ability to request the through-connection of a backward in-band message path to the calling party immediately upon the arrival of a confirmation of the call set-up. There should be a mechanism for the support of charging between the PTNO and the SP.

This is a CR and NCR requirement.

5.3.2 Routing of an originating or incoming call from the PTN to the SP

On defined criteria, the SP needs an originating or incoming call from an SP service user to be routed from the PTN to the SP, e.g. based on the dialled digits or CLI.

This is a CR requirement.

5.3.3 Indication of an originating or incoming call from the PTN to the SP

On defined criteria, the SP needs from the PTN the indication of an originating or incoming call from an SP service user e.g. based on the dialled digits or CLI.

This is an NCR requirement.

5.3.4 Routing of a terminating call from the PTN to the SP

On defined criteria, the SP needs to receive a terminating call of the SP's service user, e.g. based on the dialled digits or CLI. After that, the SP can take a further action to direct the destination and routing of the call.

This is a CR requirement.

5.3.5 Indication of a terminating call from the PTN to the SP

On defined criteria, the SP needs to receive from the PTN the indication of a terminating call to the SP's service user, e.g. based on the dialled digits or CLI.

This is an NCR requirement.

5.3.6 Reception of an indication of the cause of an unsuccessful call

On defined criteria, the SP needs to receive from the terminating PTN the indication of an unsuccessful call and the cause value, i.e. either when an indication other than "alerting tone" is returned to the calling party, or when a "no reply" situation occurs. After receiving this indication, the SP needs the ability to send a response to the PTN for further control of the call. The indication is needed on the basis of defined call unsuccessful cause values, such as "called party busy" or "no reply". There should be a mechanism for the support of charging between the PTNO and the SP.

This is a CR and NCR requirement.

5.3.7 Provision of information for the destination and routing of a call

The SP needs the ability to provide call destination and routing information. If the SP is not connected to the speech path, the SP needs to receive the indication of a call. The SP also needs the ability to return a message to the PTN for controlling the destination and routing of the call. There should be a mechanism for the support of charging between the PTNO and the SP.

This is a CR and NCR requirement.

5.3.8 Call drop-back

The SP needs the ability to drop a call back to the same PTN that delivered the call.

This is a CR requirement.

5.3.9 User interaction without service charging of the end user

The SP needs the ability to interact with the end user before any service charging begins. The end user is not charged. There should be a mechanism for the support of charging between the PTNO and the SP.

This is a CR requirement.

5.3.10 Reception of the originally dialled digits

The SP needs the ability to receive all originally dialled digits from the PTN.

This is a CR and NCR requirement.

5.3.11 Disconnection of a call in progress

The SP needs the ability to disconnect a call in progress, if either the calling or called party is a service user of the SP.

This is a CR and NCR requirement.

5.3.12 Connection of a call to an interactive voice response unit in the PTN

The SP needs the ability to instruct the PTN to connect a call to an interactive voice response (IVR) unit in the PTN.

This is an NCR requirement.

5.3.13 Alternate routing of a call or the indication of a call to another "point of presence" of the SP

The SP needs the ability to instruct the PTN to route calls or the indications of calls to another "point of presence" of the SP, if the first "point of presence" is not reachable.

This is a CR and NCR requirement.

5.4 Supplementary call and data processing capabilities

5.4.1 Interrogation of a network termination point for data delivery

The SP needs the ability to send data to and to receive data from the NTP of a service user without an alerting signal. There should be a mechanism for the support of charging between the PTNO and the SP.

This is a CR and NCR requirement.

5.4.2 Overriding of the "incoming call barring" supplementary service

The SP needs the ability to request the PTN to override any "incoming call barring" supplementary service activated on one of the SP's service users' lines, provided this is allowed by bilateral agreements between the SP and the provider of the "incoming call barring" supplementary service.

This is a CR and NCR requirement.

5.4.3 Bypassing of the "call diversion" supplementary service

The SP needs the ability to request the PTN to bypass any "call diversion" supplementary service on one of the SP's service users' lines, provided this is allowed by bilateral agreements between the SP and the provider of the "call diversion" supplementary service.

This is a CR and NCR requirement.

5.4.4 Message waiting indication

The SP needs the ability to activate and deactivate a message waiting indication to an SP service user's line.

This is a CR and NCR requirement.

5.5 Charging-related capabilities

5.5.1 Changes in the charging rate of a call

The SP needs the ability to instruct the PTN to change the charging rate of a call, applied to the SP's service user, during the call set-up phase and the duration of the call.

This is a CR and NCR requirement.

5.6 Traffic-related capabilities

5.6.1 Event traceability

The SP needs the ability to perform event traceability with the PTN, which should produce relevant call tracing data.

This is a CR and NCR requirement.

5.6.2 Traffic control capabilities

The SP needs the ability to control the signalling and/or call traffic between the SP's equipment and the PTN.

This is a CR and NCR requirement.

5.6.3 Avoidance of the cyclical routing of a call

The SP needs the ability to detect and stop cyclical routing of a call between the PTN and the SP's equipment.

This is a CR requirement.

6 Circuit-related functional requirements

6.1 Call connection scenarios

In this clause, only the CR requirements of the SPA are described. Technical aspects (which further elaborate the high-level description), examples of usage and information flow charts are presented. Furthermore, the priority (from the SP's point of view) is presented.

For clarity purposes, the distinction is made between:

- the SP originating (SPorig), that provides either:
 - services relating to the originating line (or to the originating profile), or
 - services acting on the information coming from the originating or incoming call;
- the SP terminating (SPterm) that provides either:
 - services relating to the terminating line (or to the terminating profile), or
 - services acting on the call-related information coming from the terminating party's line.

Note that this distinction does not cover the contractual relationship between the SP and its customer: some services, e.g. "freephone", are provided by the SPorig but the contractual relationship is with the terminating customer.

Also note that a SP organization could perform both the roles of SPorig and SPterm.

For calls from a calling party (CgPy) in the originating PTN (PTNorig) to a called party (CdPy) in the terminating PTN (PTNterm), in which both PTNs and SPs are involved, various call connection scenarios are possible. Figure 1 visualizes two examples of a call connection scenario from the viewpoint of the requirements of the SPs of the originating- and terminating-call-related services, called SPorig and SPterm, respectively.

Scenario A is an example of a call in which SPorig is involved. In this scenario A, the call is forwarded from the PTNorig to SPorig which provides a service to the call. SPorig returns the call to the PTNorig. The call is then forwarded from the PTNorig, eventually via a transit network (PTNtran), to the PTNterm in which the call is terminated at the called party's (CdPy) line.

Note that the scenario A in figure 1 is just one example of the possible call connection scenarios. From the SPorig onwards, there are different routing scenarios, including call connection scenarios in which the SP interacts directly with several PTNs, within the same call, if necessary, without having to relay information back to PTNorig.

Scenario B is an example of a call in which both the SPorig and the SPterm are involved. In this scenario, the call is forwarded from the PTNorig to SPorig which provides a service to the call. SPorig returns the call to the PTNorig. The call is then forwarded from the PTNorig, eventually via a transit network (PTNtran), to the PTNterm. Then, from the PTNterm the call is forwarded to SPterm which provides a service to the call. SPterm returns the call to the PTNterm, in which the call is terminated at the called party's (CdPy) line.

Note that the scenario B in figure 1 is just one example of the possible call connection scenarios. From the SPterm onwards, there are different routing scenarios, including call connection scenarios in which the SP interacts directly with several PTNs, within the same call, if necessary, without having to relay information back to PTNorig.

Note that in the case of some call connection scenarios, a SP may drop a call back to the PTN when the speech path need not be maintained via the SP during the call itself.

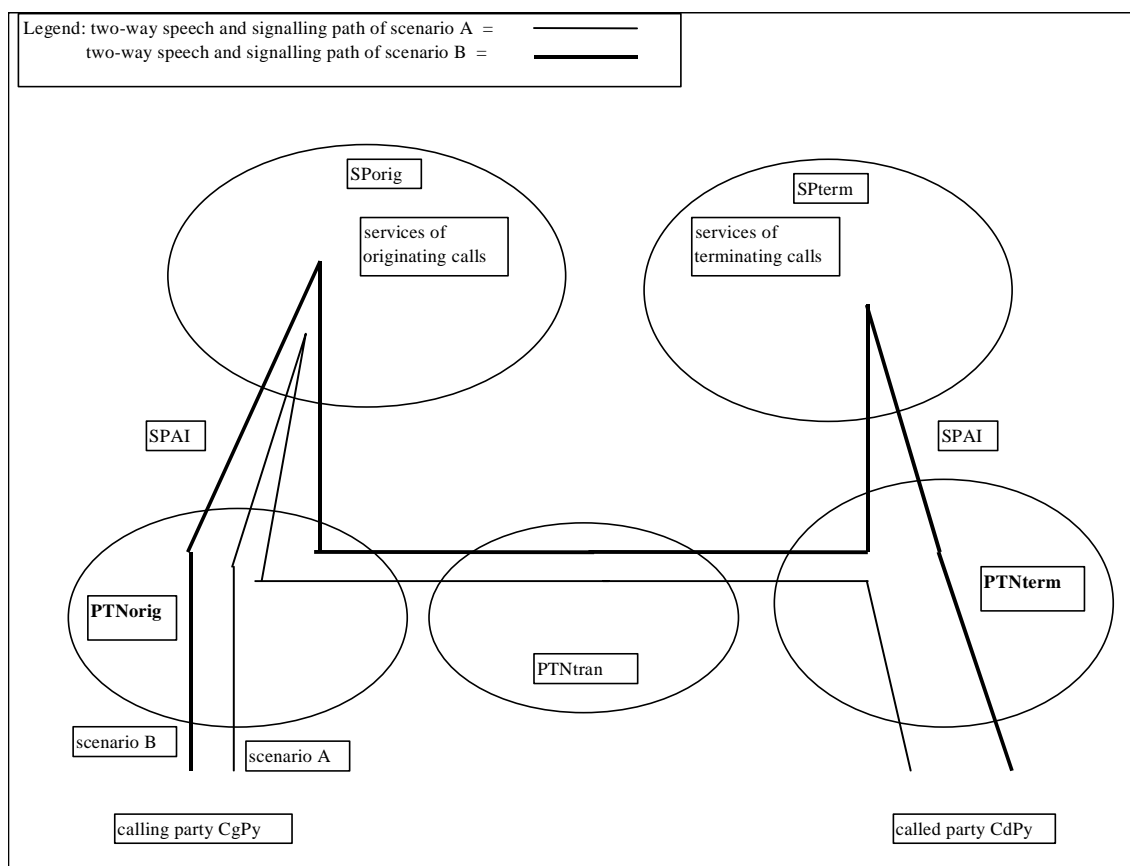

Figure 1: Examples of call connection scenarios in the case of a circuit-related SP access

In this clause, those requirements that are not relevant from the CR viewpoint are marked as "void".

6.2 Calling party information handling capabilities

6.2.1 Reception of the calling line identity

The SP needs to receive the calling line identity (CLI) from the PTN with a call, if the CLI is available in the PTN. If the calling party is using the services of the SP and national regulations and/or legislation allows it, this requirement also applies to a CLI marked as "presentation-restricted". All the indicators associated with the CLI need also to be delivered.

6.2.1.1 Priority

The priority of this requirement is high.

6.2.1.2 Example of usage

The SP needs the CLI, including all related indicators, in order to produce services such as origin dependent routing. Other services depending on CLI for user verification, such as message retrieval from personal Voice Mail services, also require CLI with all indicators.

6.2.1.3 Technical aspects

The SP needs the CLI, including all the related indicators, to initiate a forward/continued call set-up with the correct information. The "user-provided, verified and passed" or "network-provided" CLI needs to be delivered to the SP, and it needs to unambiguously identify the calling party's NTP.

The "user-provided" CLI of a call is expected to be verified by the originating PTNO. The originating access needs to provide the extension number digits to the PTNO, when appropriate. Note that the PTNO is not able to validate a "user-provided" CLI, unless it is the network number of the NTP.

6.2.1.4 Information flow chart

A message sequence scenario is presented in figure 2 from the viewpoint of the SPorig. The corresponding scenario is similar, when the SPterm receives the call from the PTNterm.

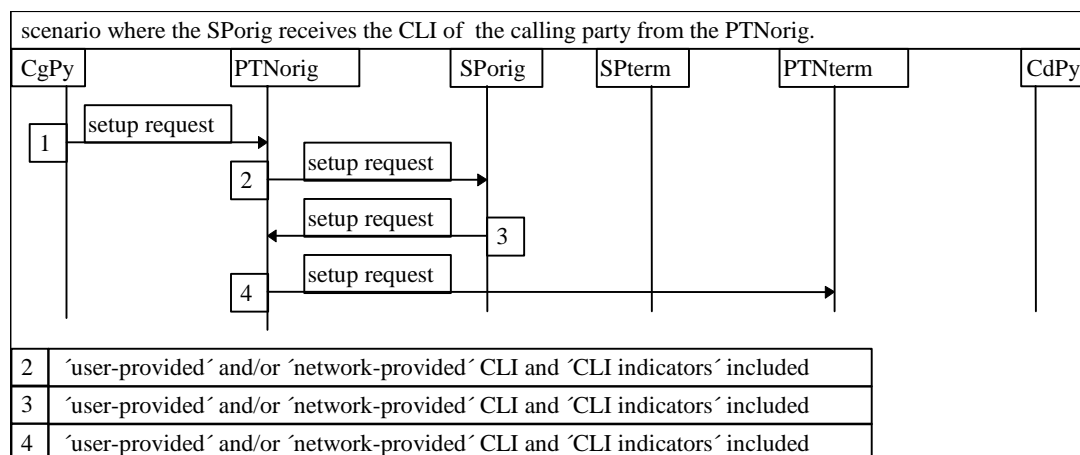

Figure 2: Reception of the calling line identity

6.2.2 Presentation of the complete CLI information to the PTN

The SP needs the ability to present all the CLI information about the calling party to the PTN. This includes the original CLI together with the related status information, as well as all the relevant indicators of the category of the call.

6.2.2.1 Priority

The priority of this requirement is high.

6.2.2.2 Example of usage

Due to the fact that other SPs may also be involved in the call set-up procedure, e.g. in the case of "service chaining", every SP and PTNO needs to be able to relay all the received information about the calling party, including the relevant indicators of the category of the call (e.g. "payphone call", "operator-initiated call"). However, for certain services, the SP may have to change part of this information, e.g. the redirection number and redirection indicator.

6.2.2.3 Technical aspects

If the called party is e.g. an alarm centre or an crisis hotline having the relevant permission to receive the CLI, and the PTNO of the called party has coded the terminating line with the "CLIR override" option [14], the called party has to be able to receive the CLI of the calling party in the same protocol data fields and with the same indicators, as if the call had been routed without the involvement of an SP.

Similarly, the called party receives the CLI unchanged, i.e. in the same protocol data fields with the same indicators, as if the call had been routed without the involvement of an SP.

Depending on bilateral agreement or national regulation, the originating PTN may restrict the information conveyed in the generic number and/or calling party number protocol parameter from being forwarded to the terminating PTN, when the CLIR supplementary service is applicable [14]. E.g. for calls to or via non-ISDNs, it can not be assured that the address presentation restriction indication can be carried to the terminating PTN. As a national option, the originating PTN may restrict information identifying the calling party from being forwarded to the terminating PTN, when the CLIR supplementary service is applicable [14]. This requirement does not imply that the SP should always forward the received information unchanged.

6.2.2.4 Information flow chart

A message sequence scenario is presented in figure 3 from the viewpoint of the SPorig. The corresponding scenario is similar, when the SPterm receives the call from the PTNterm returning it to the same network or re-routing it directly to another network.

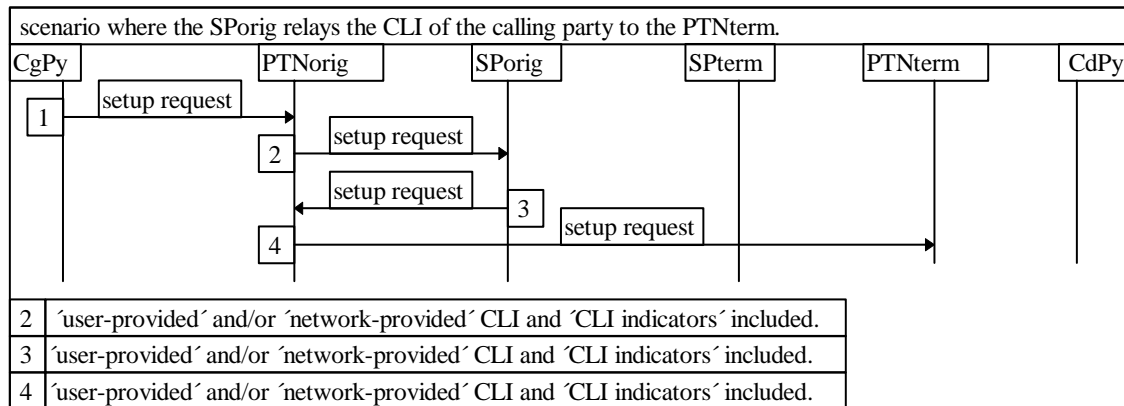

Figure 3: Presentation of the complete CLI information to the PTN

6.2.3 Addition or substitution of a calling line identity

The SP needs the ability to add or substitute the User Provided CLI to the CLI information of a call when passing it forward.

6.2.3.1 Priority

The priority of this requirement is high.

6.2.3.2 Example of usage

When the SP passes a call to the terminating PTN, an additional or alternative number may need to be delivered as a "user-provided, not screened" CLI to inform the called party of the SP or service involved.

6.2.3.3 Technical aspects

The "network provided" or "user provided, verified and passed" CLI of the calling party in the network provided CLI field shall not be replaced, but accompanied by the CLI information provided by the SP, because the original CLI also needs to be delivered.

If the called party has the relevant permission to receive the "network provided" or "user provided, verified and passed" CLI (e.g. in the case of a crisis hotline), and the PTNO term has coded the terminating line with the "CLIR override" option, this called party should be able to receive the CLI of the calling party in the same protocol data fields and with the same indicators, as if the call had been routed without the involvement of an SP.

The SP could only change the information in the user provided CLI field when previously populated by the service user:

- if, the service subscriber had contractually agreed to the SP doing so, and
- the service is a value-added feature for calls/services originated by the SP's service users.

The SP may only populate the information in the user provided CLI field where not previously populated:

- if their service subscribers had contracted to the service, and
 - the service is initiated by the SP, or
 - the service is a value-added feature for calls/services originated by the SP's service users.

6.2.3.4 Information flow chart

A message sequence scenario is presented in figure 4 from the viewpoint of the SPorig. The corresponding scenario is similar, when the SPterm receives the setup request from the PTNterm returning it to the same network or re-routing it directly to another terminating network.

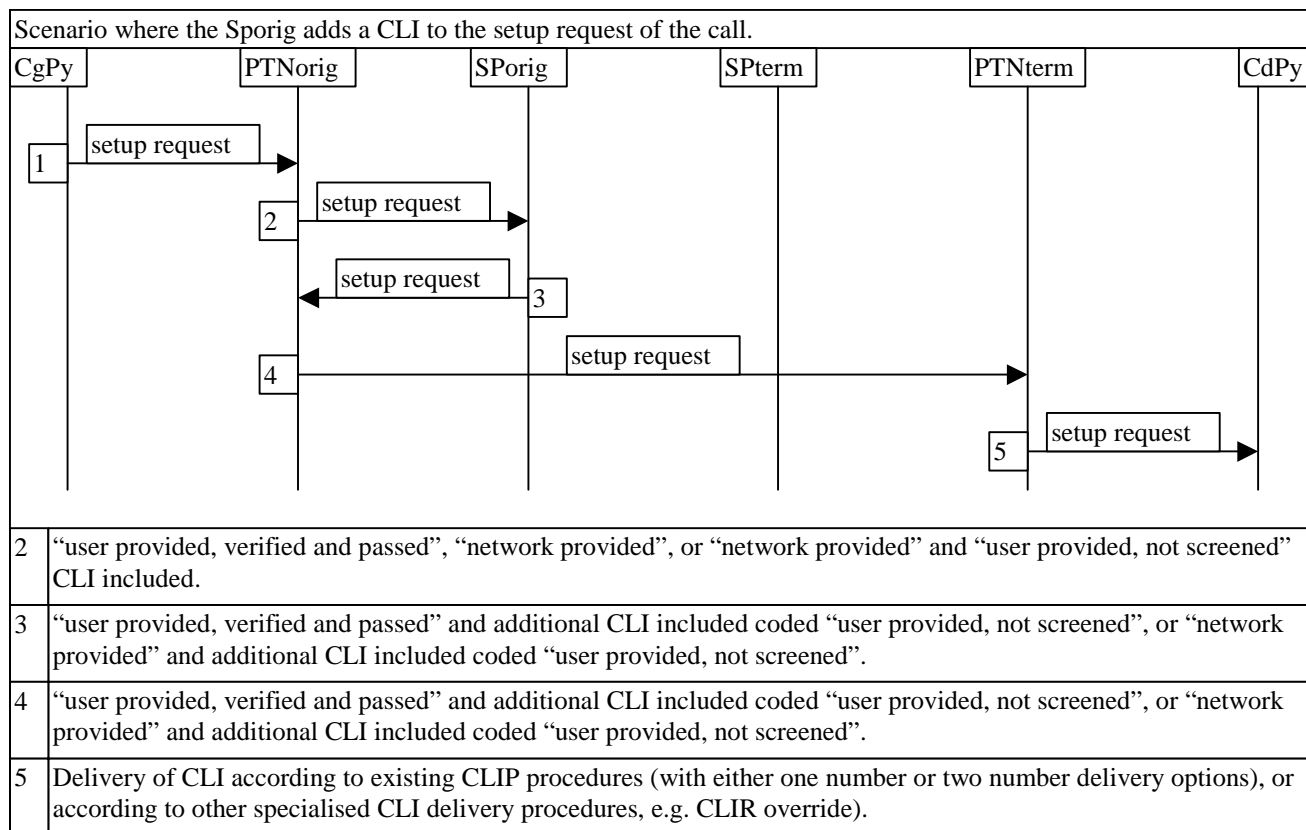

Figure 4: Addition of a calling line identity

6.2.4 Provision of CLI information to an SP-initiated call

The SP needs the ability to provide CLI information to an SP-initiated call.

6.2.4.1 Priority

The priority of this requirement is high.

6.2.4.2 Example of usage

The SP may need to provide a CLI for presentation to the end user in case of wake-up call.

6.2.4.3 Technical aspects

The CLI provided by the SP needs to be delivered as a "network-provided" CLI. In addition, the SP needs to be able to provide another service-specific number to be delivered as a "user-provided, not screened" CLI.

6.2.4.4 Information flow chart

A message sequence scenario is presented in figure 5 from the viewpoint of the SPorig.

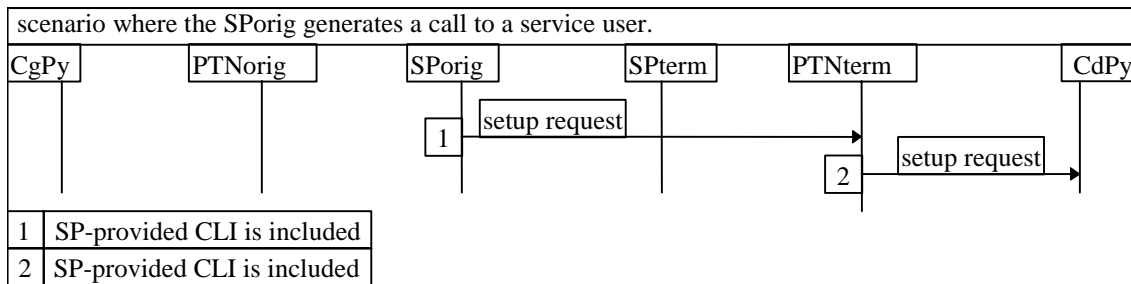

Figure 5: Provision of CLI information to an SP-initiated call

6.2.5 Relaying of the malicious call identification data of a received call

The SP needs the ability to relay all the received call-specific information unchanged to the terminating network, that may be used for malicious call tracing.

6.2.5.1 Priority

The priority of this requirement is high.

6.2.5.2 Example of usage

"Malicious call tracing" is a service example.

6.2.5.3 Technical aspects

The service logic of the SP should not interfere with the MCID supplementary service [7]. When a MCID interrogation or data logging occurs, it is necessary that the information contained in the relevant data fields is correct and represents the true identity of the NTP. SP therefore needs to forward all the received data that can be used for this purpose. Only when SP generates the call in the absence of another calling party, the SP itself is responsible for generating information that can be used for malicious call tracing.

6.2.5.4 Information flow chart

A message sequence scenario is presented in figure 6 from the viewpoint of the SPorig. The corresponding scenario is similar, when the SPterm receives the call from the PTNterm returning it to the same network or re-routing it directly to another network.

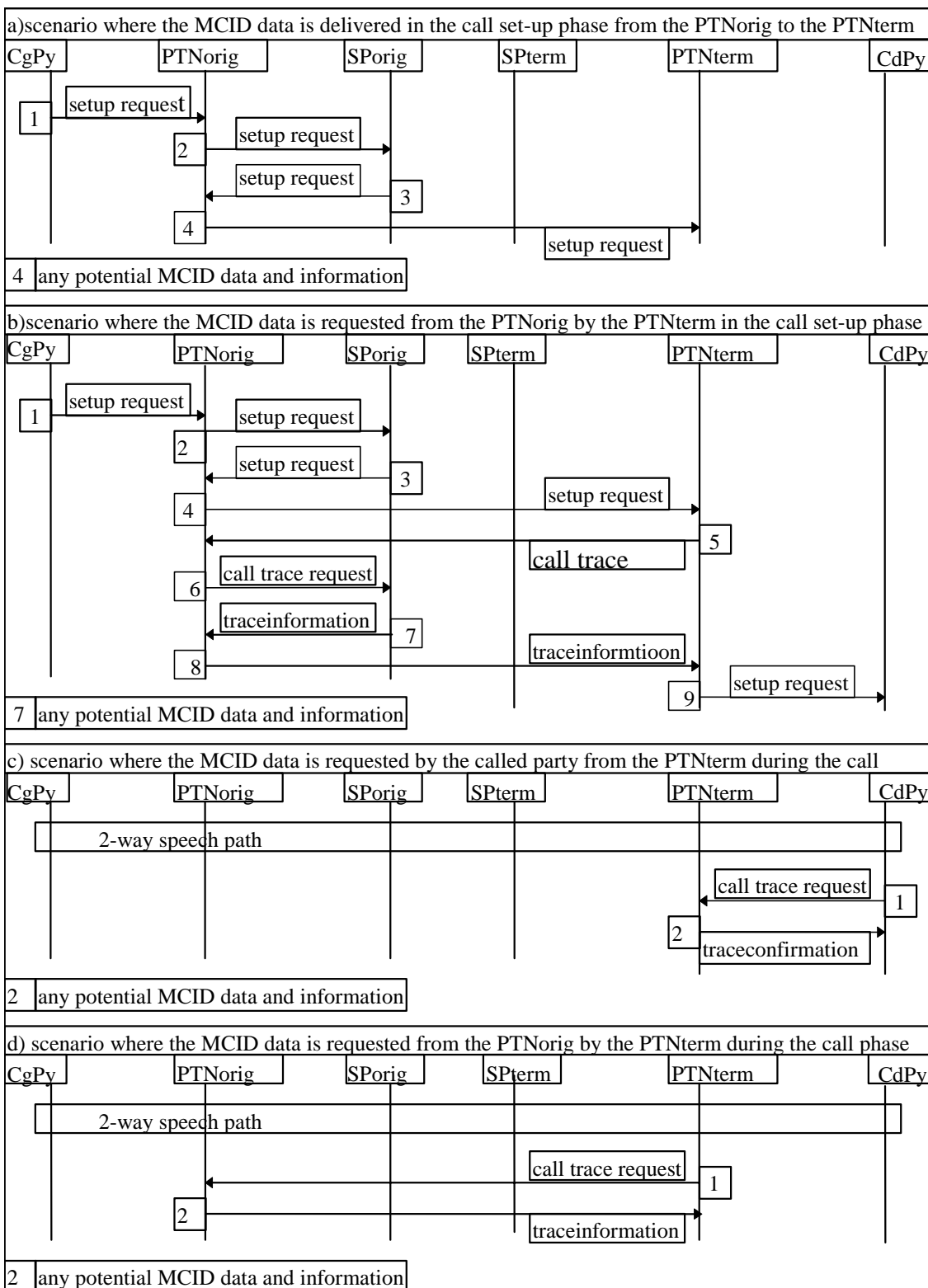

Figure 6: Relaying of the malicious call identification data of a received call

6.3 Basic call set-up and clear-down capabilities

6.3.1 Return speech path connection from the terminating PTN to the calling party

The SP needs the ability to request the through-connection of a backward in-band message path to the calling party immediately upon the arrival of a confirmation of the call set-up. There has to be a mechanism for the support of charging between the PTNO and the SP.

6.3.1.1 Priority

The priority of this requirement is high.

6.3.1.2 Example of usage

If the user of a call diversion service has specified a cellular phone as the terminating address, and the cellular phone happens to be out of radio coverage, the terminating PTN plays an in-band message, in order to inform the calling party that the called party is not reachable.

6.3.1.3 Technical aspects

The required capability is needed for relaying in-band messages related to the call set-up from the terminating PTN to the calling party without returning an "answer" signal. The required capability needs to be similar to the corresponding capability of the PTNO, i.e. without the returning of an "answer" signal. Depending on the inter-network signalling systems used, it is possible that a return speech path is built from the calling party to the terminating network during the forward signalling phase.

6.3.1.4 Information flow chart

A message sequence scenario is presented in figure 7 from the viewpoint of both the SPorig and SPterm.

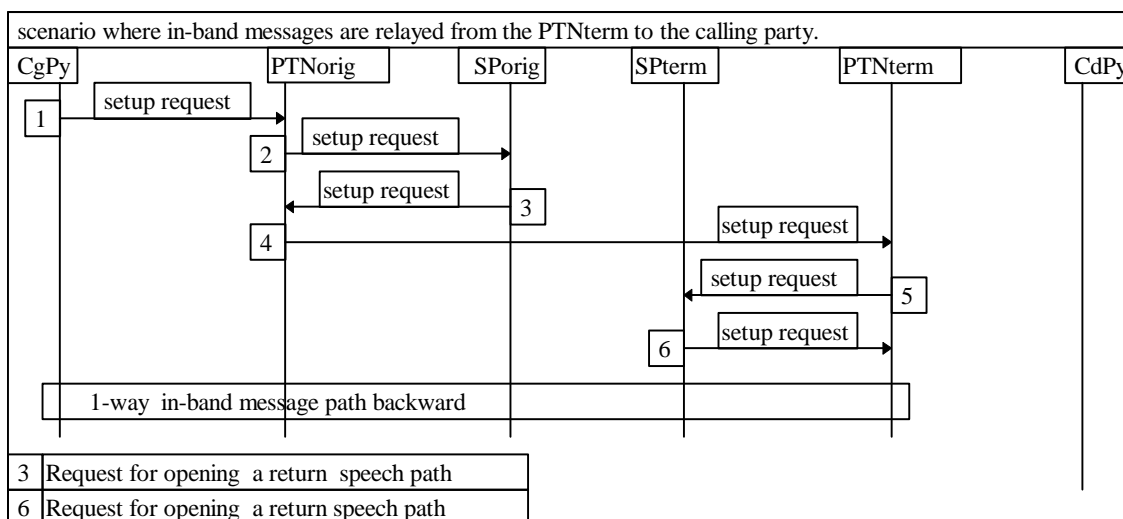

Figure 7: Return speech path connection from the PTNterm to the calling party

6.3.2 Routing of an originating or incoming call from the PTN to the SP

On defined criteria, the SP needs an originating or incoming call of the SP's service user to be routed from the PTN to the SP, e.g. based on the dialled digits or CLI.

6.3.2.1 Priority

The priority of this requirement is high.

6.3.2.2 Example of usage

"Freephone" and "selective call barring" are examples.

6.3.2.3 Technical aspects

An originating call may be routed to a SP on defined criteria to enable the SP to control further routing of the call, e.g. via a translation of the dialled number. Examples of these criteria are:

- a call dialled with a prefix that identifies the SP;
- a call dialled without an "escape" prefix;
- a call with the CLI of the calling party in a specific number range (not applicable in the case of number portability);
- a call made by a specific calling party (i.e. CLI);
- a call made at a specific NTP; or
- a call directed to a specific destination or subdestination.

Interactions between the above-mentioned criteria and the existing carrier selection and carrier pre-selection criteria may occur.

The dialled digits can represent either a normal called party number or an indicator (e.g. a prefix or a short code) that can be used to select a SP directly or to prompt for further digits for the selection.

After receiving the call from the PTN, the SP is able to control the destination and routing of the call, e.g. in the form of a new destination number and possibly a set of digits for carrier selection.

When an end user makes a call and the dialled digits are analysed, the call is forwarded to the SP containing data, such as the identity of the original calling party's line (i.e. CLI) and the dialled digits.

Access to the emergency services is considered. The network may need to trap specific calls, e.g. emergency calls, instead of routing these calls to the SP.

The routing to the SP in case of detection of an end user's off-hook may require special arrangements to handle emergency calls.

6.3.2.4 Information flow chart

A message sequence scenario is presented in figure 8 from the viewpoint of the SPorig.

The SPorig may be connected to only one PTN, in which case the onward routing of the call will always take place via this network (PTNorig, scenario a). Alternatively, the SPorig may have a possibility to route the call via another network (PTNterm, scenario b).

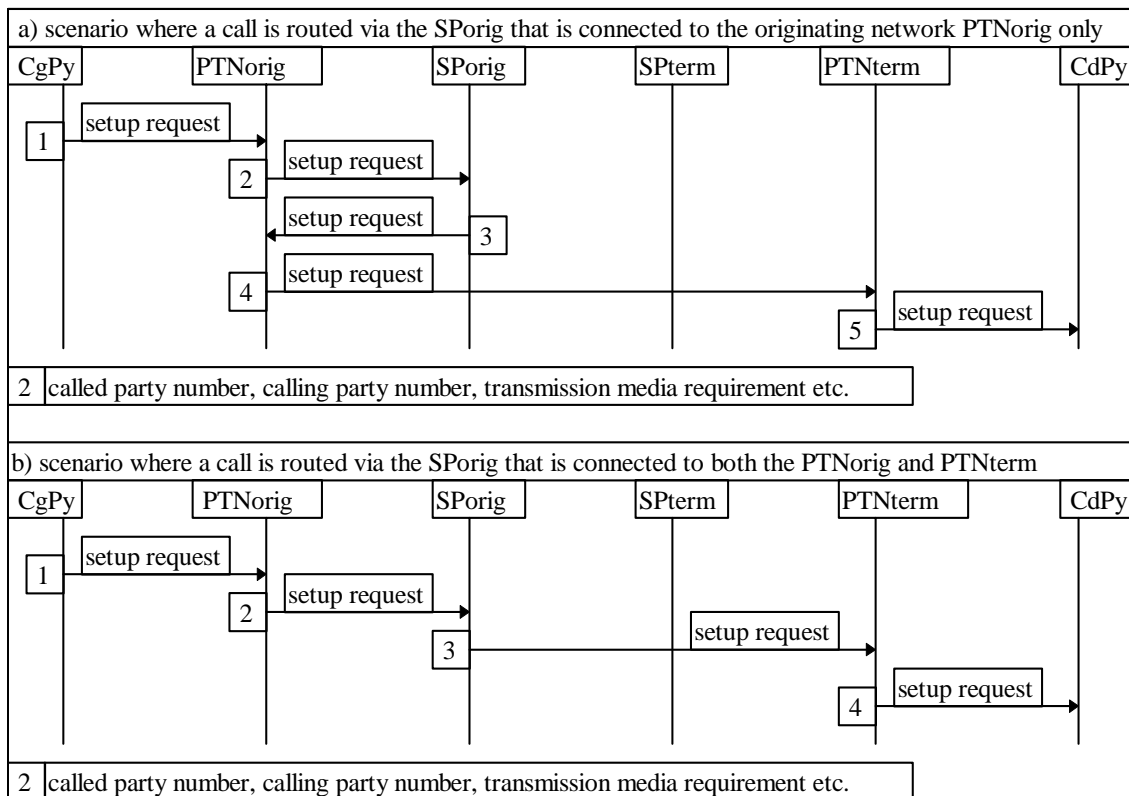

Figure 8: Routing of an originating or incoming call from the PTN to the SP

6.3.3 Indication of an originating or incoming call from the PTN to the SP

Void.

6.3.4 Routing of a terminating call from the PTN to the SP

On defined criteria, the SP needs to receive a terminating call of the SP's service user, e.g. based on the dialled digits or CLI. After that, the SP can take a further action to direct the destination and routing of the call.

6.3.4.1 Priority

The priority of this requirement is high.

6.3.4.2 Example of usage

"Distinctive ringing" and "terminating call screening" services are examples.

6.3.4.3 Technical aspects

Depending on the type of the service, a call may need to be routed by the terminating PTN to the SP on defined criteria, e.g. when the called party is a service user of the SP. After that, the SP can take an action to control the destination and routing. Examples of these criteria are:

- a call to a dialled number that is a specific number range;
- a call to a specific dialled number;
- a call that is destined to a specific number and is unsuccessful for some reason;
- a call that is unsuccessful for some reason with the dialled number being in a specific number range; or

- a call of a particular type destined to an individual number or number block (e.g. long-distance calls or international calls).

After receiving the routing number, the SP can provide the PTN a new number, which may include the actual destination number preceded by a set of digits for carrier selection purposes. This new number provided by the SP shall comply with the numbering plan.

The requirement is only applicable when the routing number uniquely identifies the terminating NTP (e.g. in the case of an ordinary geographic number).

The routing of a call to the SP can be accomplished in the terminating PTN by means of the call forwarding capability.

6.3.4.4 Information flow chart

A message sequence scenario is presented in figure 9 from the viewpoint of the SPterm.

The SPterm may be connected to only one PTN, in which case the onward routing of the call will always take place via this network (PTNterm, scenario a and b). Alternatively, the SPterm may have a possibility to route the call via another network (PTNterm[^], scenario c).

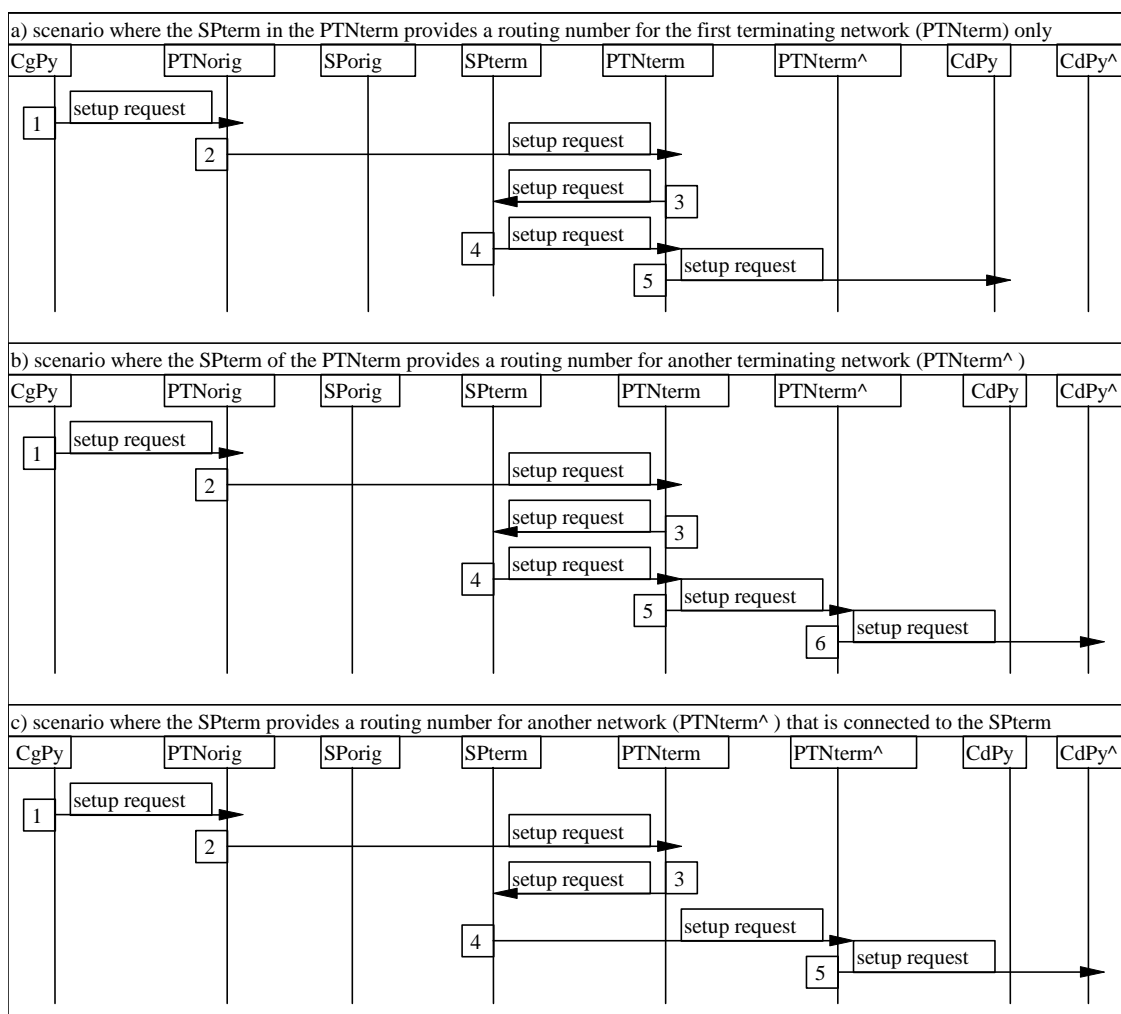

Figure 9: Routing of a terminating call from the PTNterm to the SP

6.3.5 Indication of a terminating call from the PTN to the SP

Void.

6.3.6 Reception of an indication of the cause of an unsuccessful call

On defined criteria, the SP needs to receive from the terminating PTN the indication of an unsuccessful call and the cause value, i.e. either when an indication other than "alerting tone" is returned to the calling party, or when a "no reply" situation occurs. After receiving this indication, the SP needs the ability to send a response to the PTN for further control of the call. The indication is needed on the basis of defined call unsuccessful cause values, such as "called party busy" or "no reply". There should be a mechanism for the support of charging between the PTNO and the SP.

6.3.6.1 Priority

The priority of this requirement is high.

6.3.6.2 Example of usage

Routing a call to a voice messaging system in the event that the called party is busy can be given as an example.

6.3.6.3 Technical aspects

A call is considered to be unsuccessful, if e.g.:

- the destination is busy;
- a timeout expires (e.g. in case of a "no reply" situation);
- the call is rejected at the destination;
- the destination is not reachable;
- the dialled number is invalid;
- the network is congested; or
- there is a routing error (i.e. a route selection failure).

If the SP is connected to the speech path, the indication of an unsuccessful call can be received from the terminating PTN.

6.3.6.4 Information flow chart

In figure 10, a message sequence scenario is presented from the viewpoint of the SP_{orig} in the presence of a speech path connection, assuming that the SP_{orig} is connected to only the PTN_{orig} and the call is unsuccessful due to the called party being busy (scenario a) or rejecting the call (scenario b).

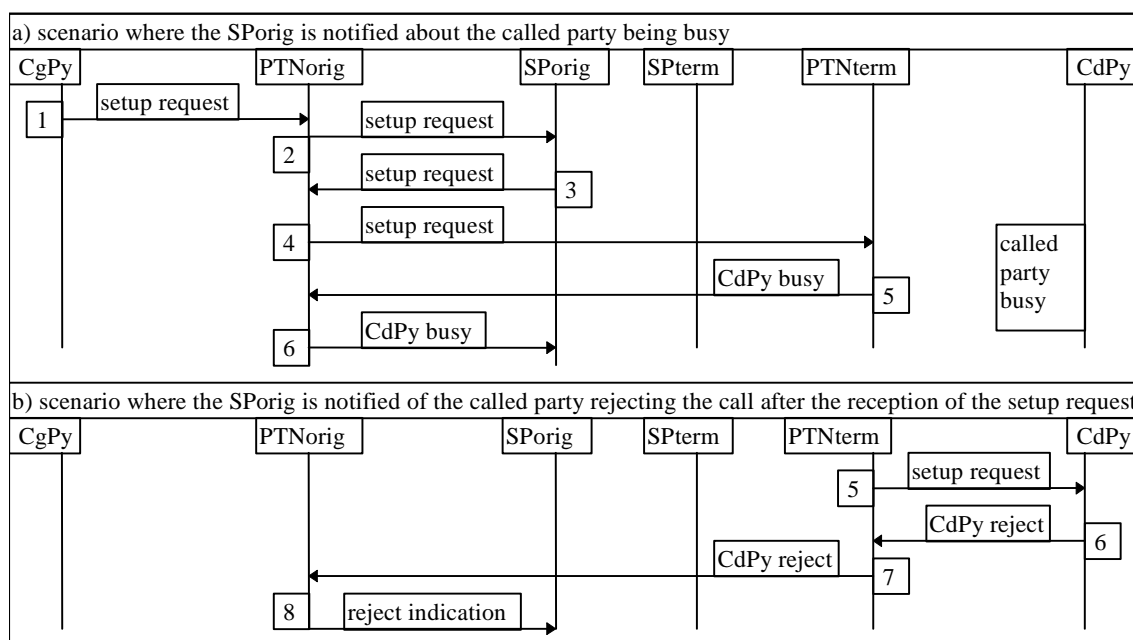

Figure 10: Reception of an indication of the cause of an unsuccessful call

6.3.7 Provision of information for the destination and routing of a call

The SP needs the ability to provide call destination and routing information. If the SP is not connected to the speech path, the SP needs to receive the indication of a call. The SP also needs the ability to return a message to the PTN for controlling the destination and routing of the call. There should be a mechanism for the support of charging between the PTNO and the SP.

6.3.7.1 Priority

The priority of this requirement is high.

6.3.7.2 Example of usage

In the connection of many services, the SP needs to provide an actual routing number to the PTN on the basis of the dialled number.

6.3.7.3 Technical aspects

The PTN can route the call to the SP for instructions regarding the destination and routing of the call.

6.3.7.4 Information flow chart

The PTN routes the call to the SPorig as described in figure 11.

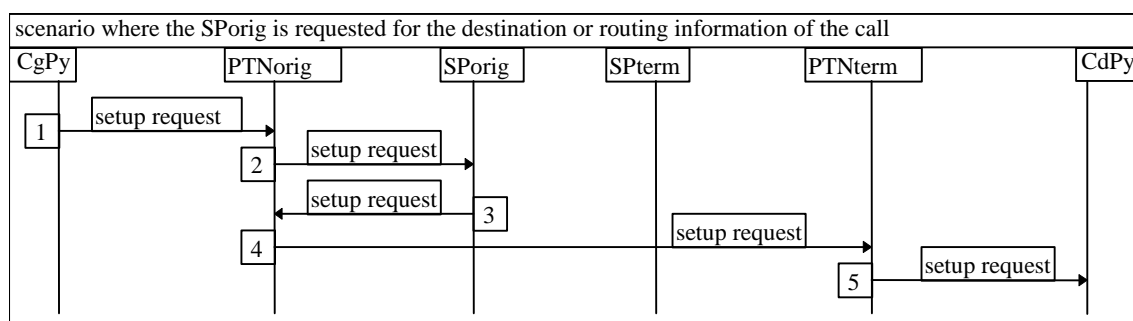

Figure 11: Provision of information for the destination and routing of a call

6.3.8 Call drop-back

The SP needs the ability to drop a call back to the same PTN that delivered the call.

6.3.8.1 Priority

The priority of this requirement is medium.

6.3.8.2 Example of usage

Route optimization is an example.

6.3.8.3 Technical aspects

Call drop-back is an approach to release the usage of network resources that are not needed throughout the duration of the call after the intervention of the SP during the call set-up phase.

Number analysis is needed before call drop-back may occur. There are certain call destinations that do not allow call drop-back to be invoked. Both the trunks and the signalling are dropped back.

6.3.8.4 Information flow chart

A message sequence scenario is presented in figure 12 from the viewpoint of the SPorig. The corresponding scenario is similar, when the SPterm receives the setup request from the PTNterm.

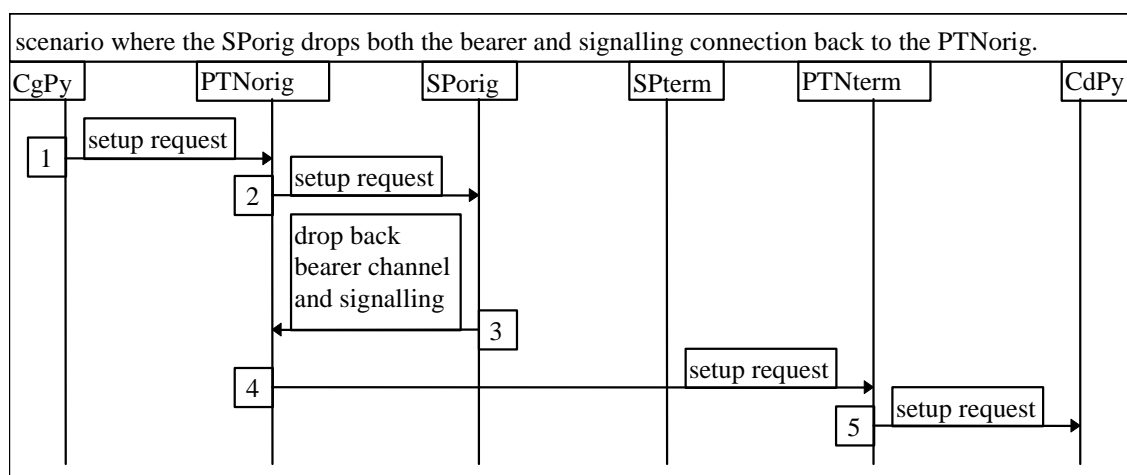

Figure 12: Call drop-back

6.3.9 User interaction without service charging of the end user

The SP needs the ability to interact with the end user before any service charging begins. The end user is not charged. There should be a mechanism for the support of charging between the PTNO and the SP.

6.3.9.1 Priority

The priority of this requirement is medium.

6.3.9.2 Example of usage

The SPs and PTNs utilizing the relevant signalling protocols are able to open speech paths in both directions during the call set-up phase before the call reaches its final destination and the charging is applied. This capability is often used by SPs to allow menus etc. for user-controlled intelligent routing of the call.

6.3.9.3 Technical aspects

The SPs and PTNs need the ability to through-connect the speech path in both directions during the call set-up phase before the call reaches its final destination and the charging is applied.

6.3.9.4 Information flow chart

A message sequence scenario is presented in figure 13 from the viewpoint of the SPorig.

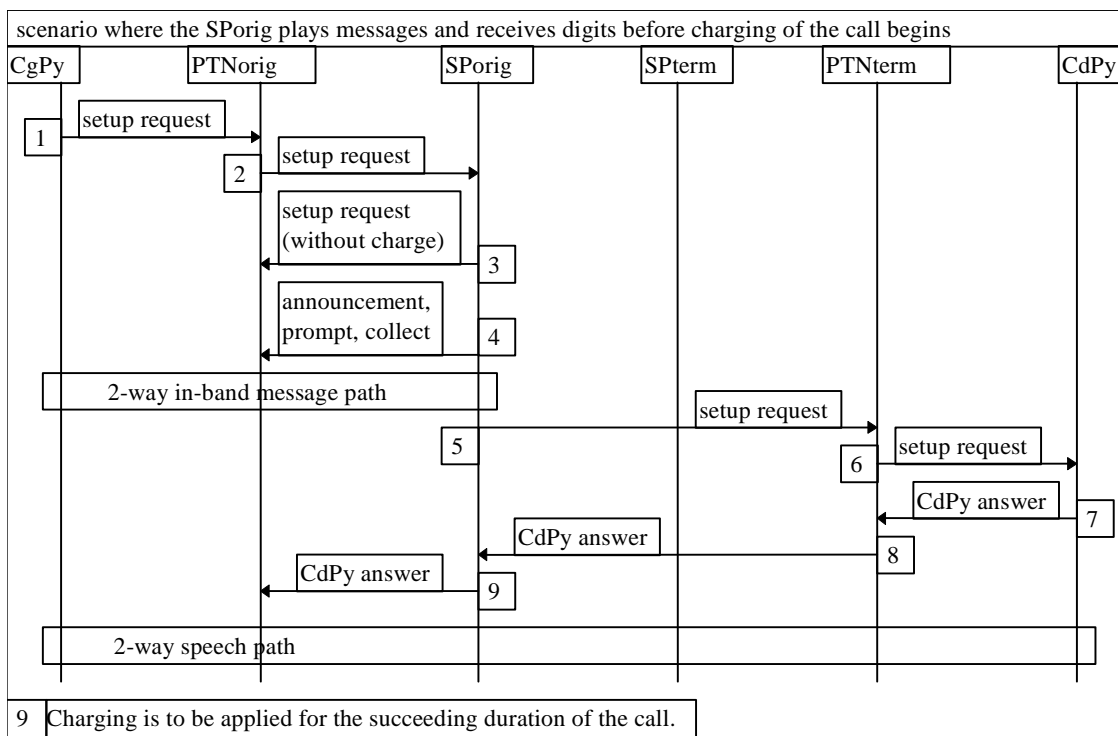

Figure 13: User interaction without service charging

Figure 14: Void

6.3.10 Reception of the originally dialled digits

The SP needs the ability to receive all originally dialled digits from the PTN.

6.3.10.1 Priority

The priority of this requirement is low.

6.3.10.2 Example of usage

The SP needs to know the original number that was dialled, e.g. in the case of a "freephone" or "follow-me" number.

6.3.10.3 Technical aspects

This requirement is also valid when the dialled number has been translated before the SP receives a call.

If the originating PTN has translated the dialled number and the SP requires the originally dialled digits, then the SP needs both the routing number and all originally dialled digits.

6.3.10.4 Information flow chart

The flowcharts in figure 15 describe message sequence scenarios in a situation where the call itself is connected to the SP's equipment. Since the SPorig or SPterm is connected to the speech path, the original dialled number is expected to be available in the setup request that is provided by the PTN.

The first flowchart a) in figure 15 presents a message sequence scenario from the viewpoint of the SPorig and SPterm when the dialled number is not translated before the PTNterm receives the call. The second flowchart b) presents the corresponding scenario assuming that the SPorig performs a number translation. After that, both the dialled number (DNr) and the current routing number (RNr[^]) are carried forwards.

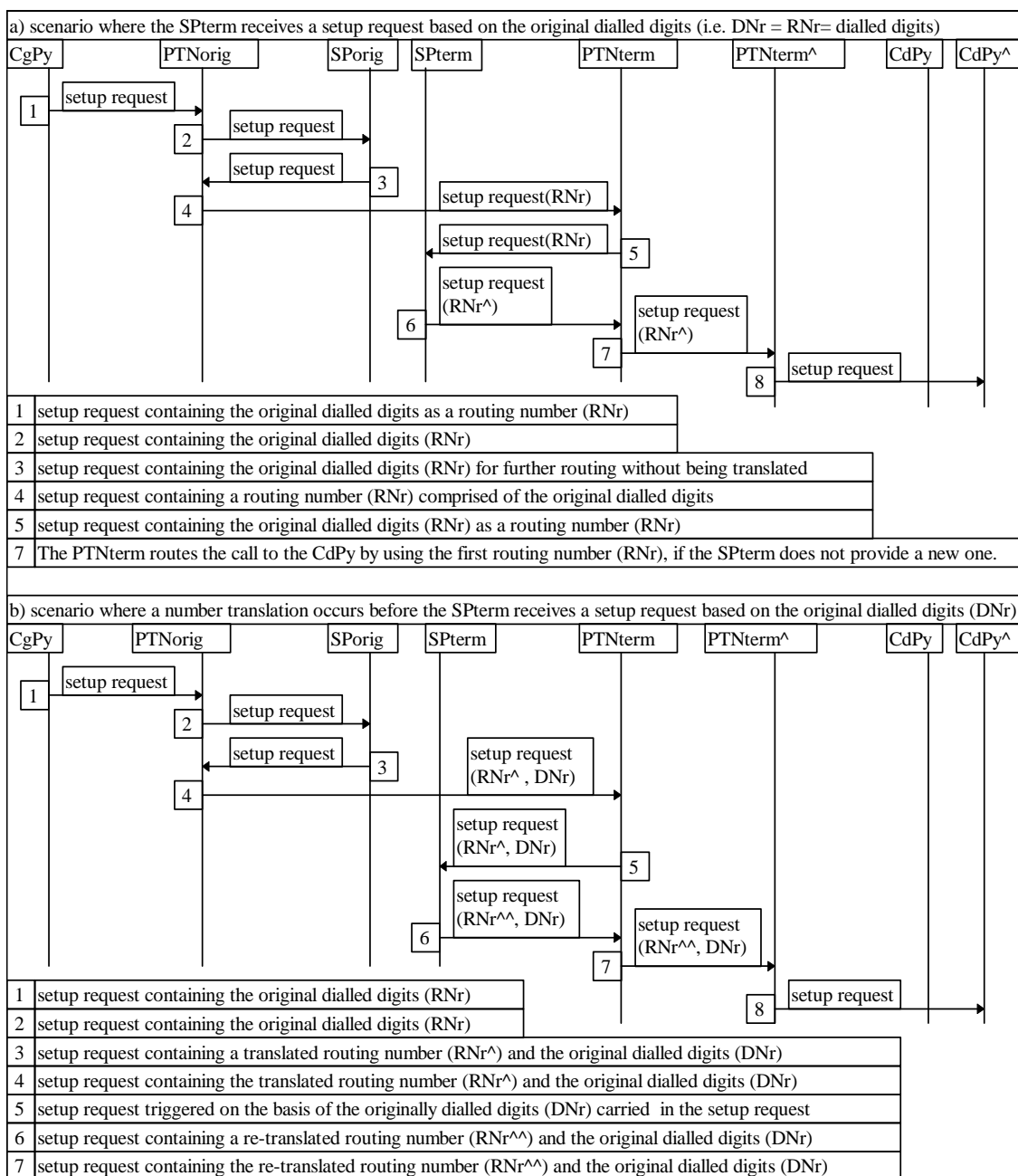

Figure 15: Reception of the originally dialled digits

6.3.11 Disconnection of a call in progress

The SP needs the ability to disconnect a call in progress, if either the calling or called party is a service user of the SP.

6.3.11.1 Priority

The priority of this requirement is medium.

6.3.11.2 Example of usage

Calling card running out of credit is an example.

6.3.11.3 Technical aspects

If the SP is connected to the speech path, the disconnection capability is technically available.

6.3.11.4 Information flow chart

The first flowchart a) in figure 16 presents a message sequence scenario from the viewpoint of the SPorig. The second flowchart b) presents the corresponding scenario assuming that the SPterm disconnects the call.

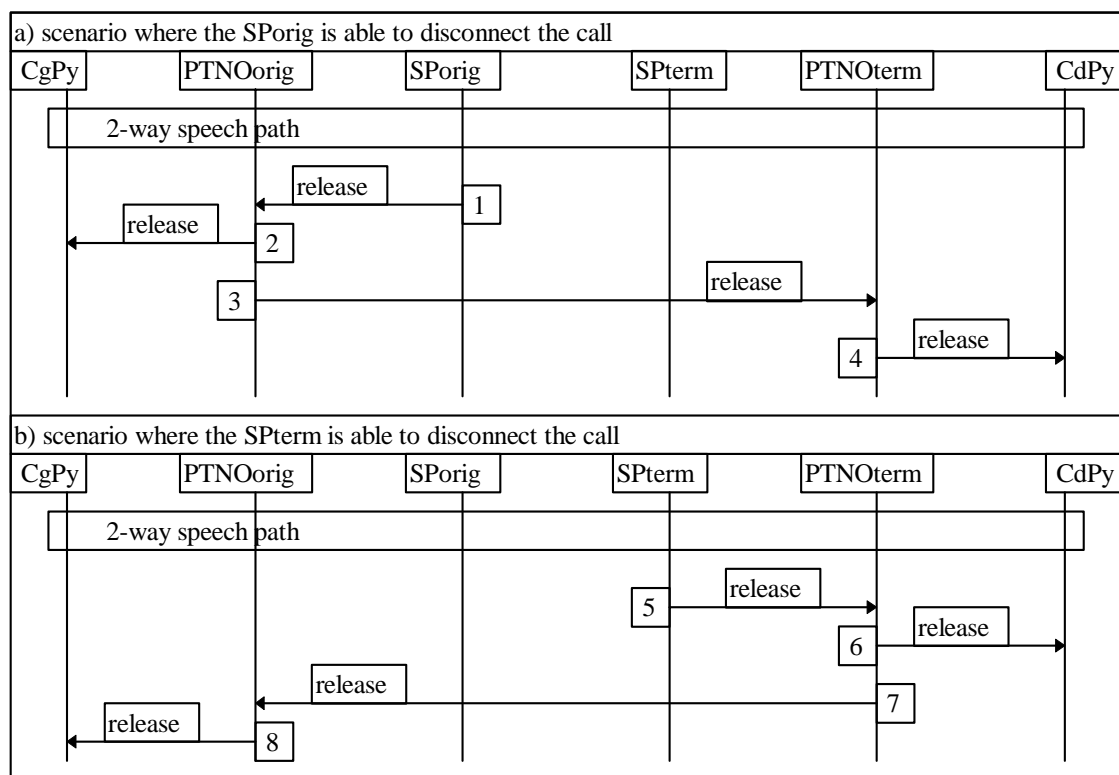

Figure 16: Disconnection of a call in progress

6.3.12 Connection of a call to an interactive voice response unit in the PTN

Void.

6.3.13 Alternate routing of a call or the indication of a call to another "point of presence" of the SP

The SP needs the ability to instruct the PTN to route calls or the indications of calls to another "point of presence" of the SP, if the first "point of presence" is not reachable.

6.3.13.1 Priority

The priority of this requirement is medium.

6.3.13.2 Example of usage

For reliability or capacity reasons, the SP may have several "points of presence", i.e. network interconnection points between the SP and PTN. The capability to instruct a PTN about the configuration of the routing of traffic to "points of presence" can be useful in case a particular "point of presence" is out of service e.g. in case of maintenance.

6.3.13.3 Technical aspects

This alternate routing is not needed on a call by call basis.

6.3.13.4 Information flow chart

The following flowchart in figure 17 presents the provision of the address data of another "point of presence" to the PTN.

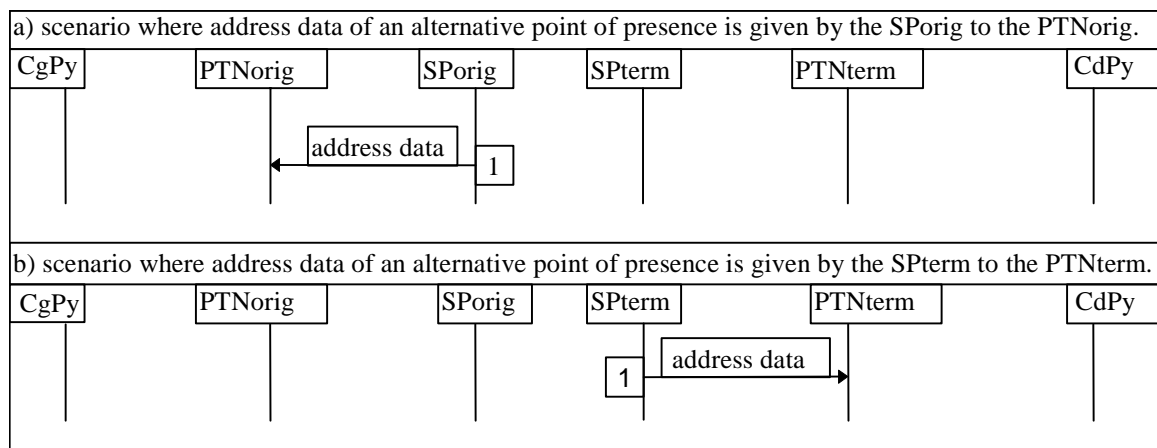

Figure 17: Alternate routing of a call or the indication of a call to another "point of presence" of the SP

6.4 Supplementary call and data processing capabilities

6.4.1 Interrogation of a network termination point for data delivery

The SP needs the ability to send data to and to receive data from the NTP of a service user without an alerting signal. There should be a mechanism for the support of charging between the PTNO and the SP.

6.4.1.1 Priority

The priority of this requirement is medium.

6.4.1.2 Example of usage

"Remote meter reading" service is an example.

6.4.1.3 Technical aspects

The required capability is also called "Collection of Telemetry". In the longer term, "collection of telemetry" could be possible without setting up a call. Note that different solutions may be applicable to the ISDN users. One solution could be that the NTP would have a capability to recognize the SP's CLI in the case of a terminating call and the CPE would be able to answer the call without any user intervention. The interrogation may be difficult in the case of a CR interface due to the call state model of the ISDN access line.

6.4.1.4 Information flow chart

The flowchart in figure 18 presents a message sequence scenario from the viewpoint of the SPterm, because the called party is located in the PTNterm and the SP in that network is called SPterm.

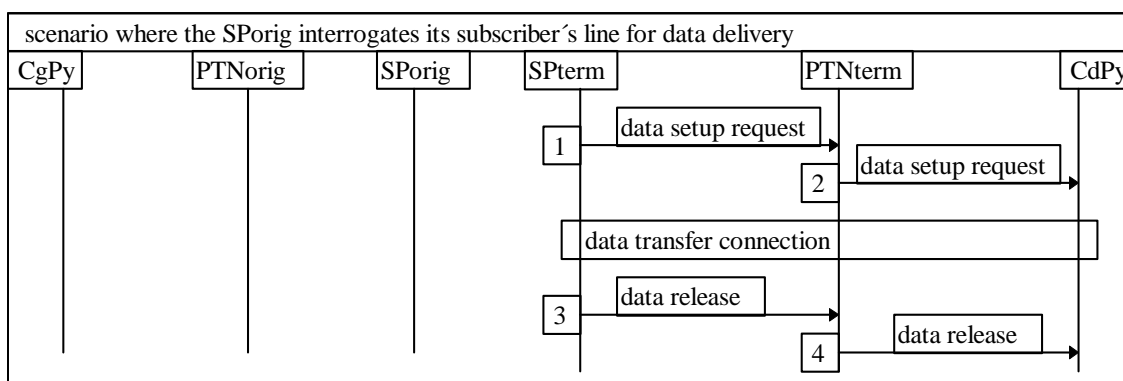

Figure 18: Interrogation of a network termination point for data delivery

6.4.2 Overriding of the "incoming call barring" supplementary service

The SP needs the ability to request the PTN to override any "incoming call barring" supplementary service activated on one of the SP's service users' lines, provided this is allowed by bilateral agreements between the SP and the provider of the "incoming call barring" supplementary service.

6.4.2.1 Priority

The priority of this requirement is high.

6.4.2.2 Example of usage

SP management access to a "premium rate" service line, e.g. in the case of entertainment services, is an example.

6.4.2.3 Technical aspects

"Incoming call barring" and similar supplementary services are often used to protect the underlying phone numbers of special service subscribers (e.g. premium rate numbers) against direct access and thus fraud. The dialled number has to be converted into a call with a routing number to pass through this call barring, and an indicator is applied in the call setup message. Overriding of this call barring may be achieved by the use of relevant indicators. Calls where the "overriding" and "number translation" indicators match may override this call barring. Otherwise, the call may be rejected.

6.4.2.4 Information flow chart

The flowchart in figure 19 presents a message sequence scenario from the viewpoint of the SPterm, because the "incoming call barring" is a supplementary service of the called party.

In this scenario, the call itself is connected to the SP's equipment. Since the SPterm is connected to the speech path, the PTNterm sends the setup request to the SPterm.

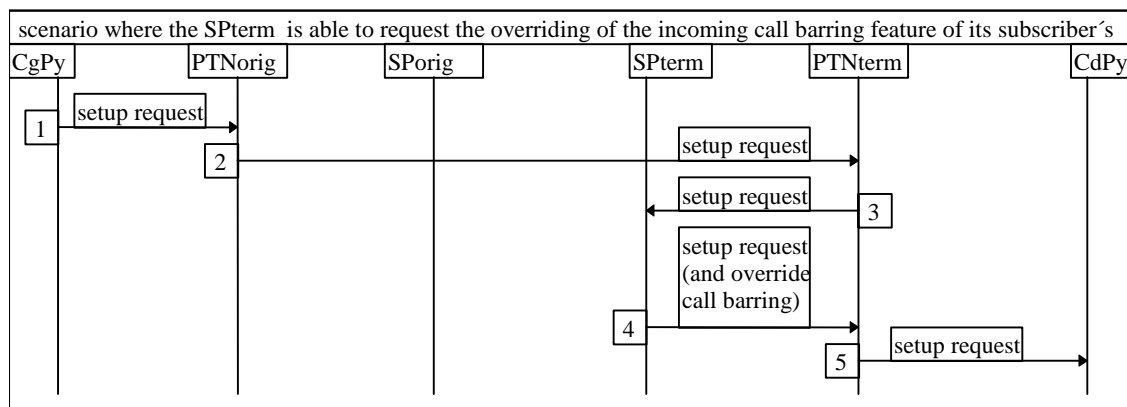

Figure 19: Overriding of the "incoming call barring" supplementary service

6.4.3 Bypassing of the "call diversion" supplementary service

The SP needs the ability to request the PTN to bypass any "call diversion" supplementary service on one of the SP's service users' lines, provided this is allowed by bilateral agreements between the SP and the provider of the "call diversion" supplementary service.

6.4.3.1 Priority

The priority of this requirement is low.

6.4.3.2 Example of usage

An example is the case where a service subscriber has diverted all calls to an answering service, but the SP needs to bypass the call diversion for a wake-up call.

6.4.3.3 Technical aspects

This requirement can be fulfilled by activating a call diversion service for the SP's service user in the related local exchange towards the SP [8]. In order to complete the required service, the SP needs the ability to bypass a call diversion service, i.e. to route the terminating call through to the called party.

An end user may wish to receive calls from only those callers who have the CLIP [2] supplementary service active. One possibility is to block all the calls that are associated with an active CLIR [14] supplementary service. Alternatively, the end user may want to allow the access to only selected calling parties or to deny the access from specified calling parties.

The SP may be able to cut through and bypass the call diversion, by placing a call with a "bypass indicator" set, to the service user.

6.4.3.4 Information flow chart

The flowchart in figure 20 presents a message sequence scenario from the viewpoint of the SPterm, because the "call diversion" is a supplementary service of the called party. In this scenario, the call itself is connected to the SP's equipment. Since the SPterm is connected to the speech path, the PTNterm sends the setup request to the SPterm.

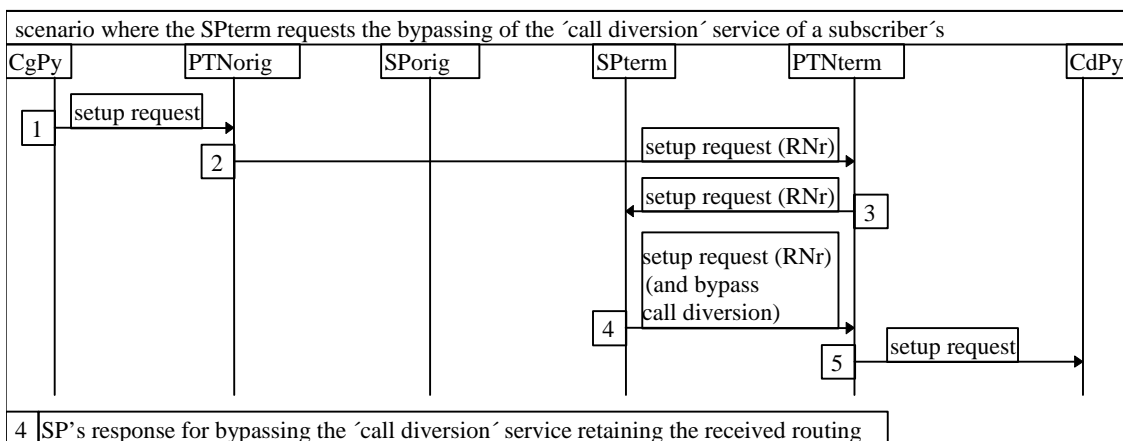

Figure 20: Bypassing of the call diversion supplementary service

6.4.4 Message waiting indication

The SP needs the ability to activate and deactivate a message waiting indication to an SP service user's line.

6.4.4.1 Priority

The priority of this requirement is high.

6.4.4.2 Example of usage

"Notification of the arrival of an e-mail message" service is an example.

6.4.4.3 Technical aspects

This may be implemented as "distinctive ringing" or a "call-back" after a call has been made or received.

6.4.4.4 Information flow chart

The flowchart in figure 21 describes the related message sequence scenarios from the viewpoint of the SPterm, because the message waiting indication is a service of the called party.

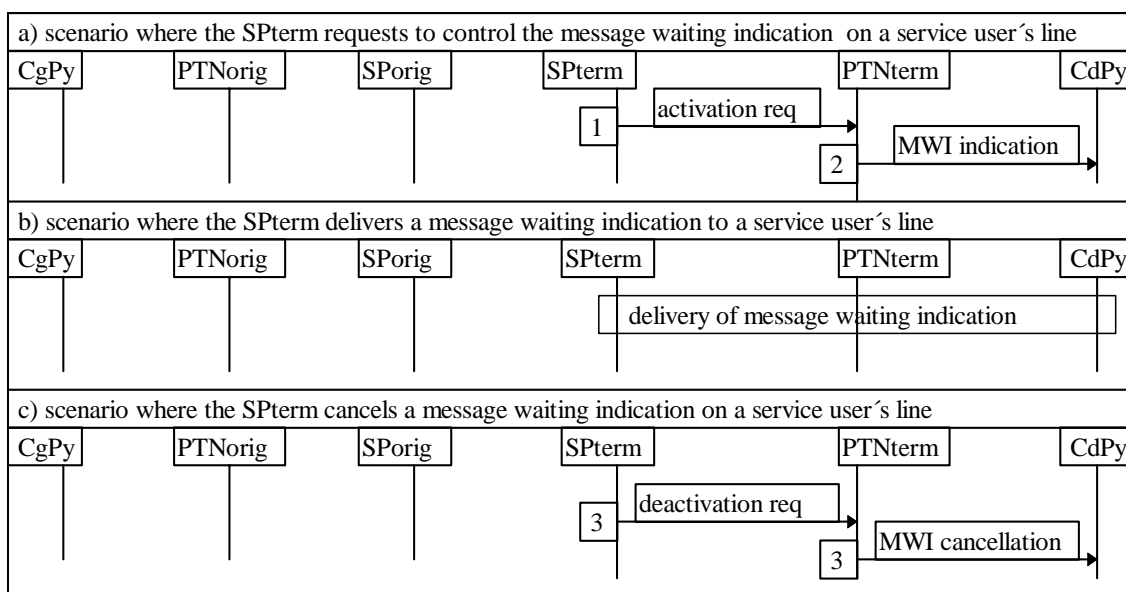

Figure 21: Message waiting indication

6.5 Charging-related capabilities

6.5.1 Changes in the charging rate of a call

The SP needs the ability to instruct the PTN to change the charging rate of a call, applied to the SP's service user, during the call set-up phase and the duration of the call.

6.5.1.1 Priority

The priority of this requirement is high.

6.5.1.2 Example of usage

A service example is a remotely located menu-based selection of services where the charge rate depends on the choice made by the calling party.

6.5.1.3 Technical aspects

The request to the SP to change the charging rate may be invoked by an external event, possibly after a request from either the calling or called party. Normally, the call charge rate is determined during the call set-up phase, based on the number dialled, time of day, day of week etc. To control the charging flexibly in such a situation, the remote unit (CPE of the called party or the SP) needs the ability to send a message to the SP's service control system, for authorization and further processing.

The interface between the CgPy/CdPy and PTN/SP shall accommodate the necessary events required by the service, such as the appropriate mid-call triggering criteria.

Charging aspects need to be considered in the case of multiple PTNs and SPs.

6.5.1.4 Information flow chart

Message sequence scenarios a), b) and c) in figure 22 describe, how the SPorig in the PTNorig instructs the PTNorig during a call that the charging rate should be changed. In scenario d), the called party's CPE informs the SPorig about the need of a rate change (e.g. in the case of a premium rate service).

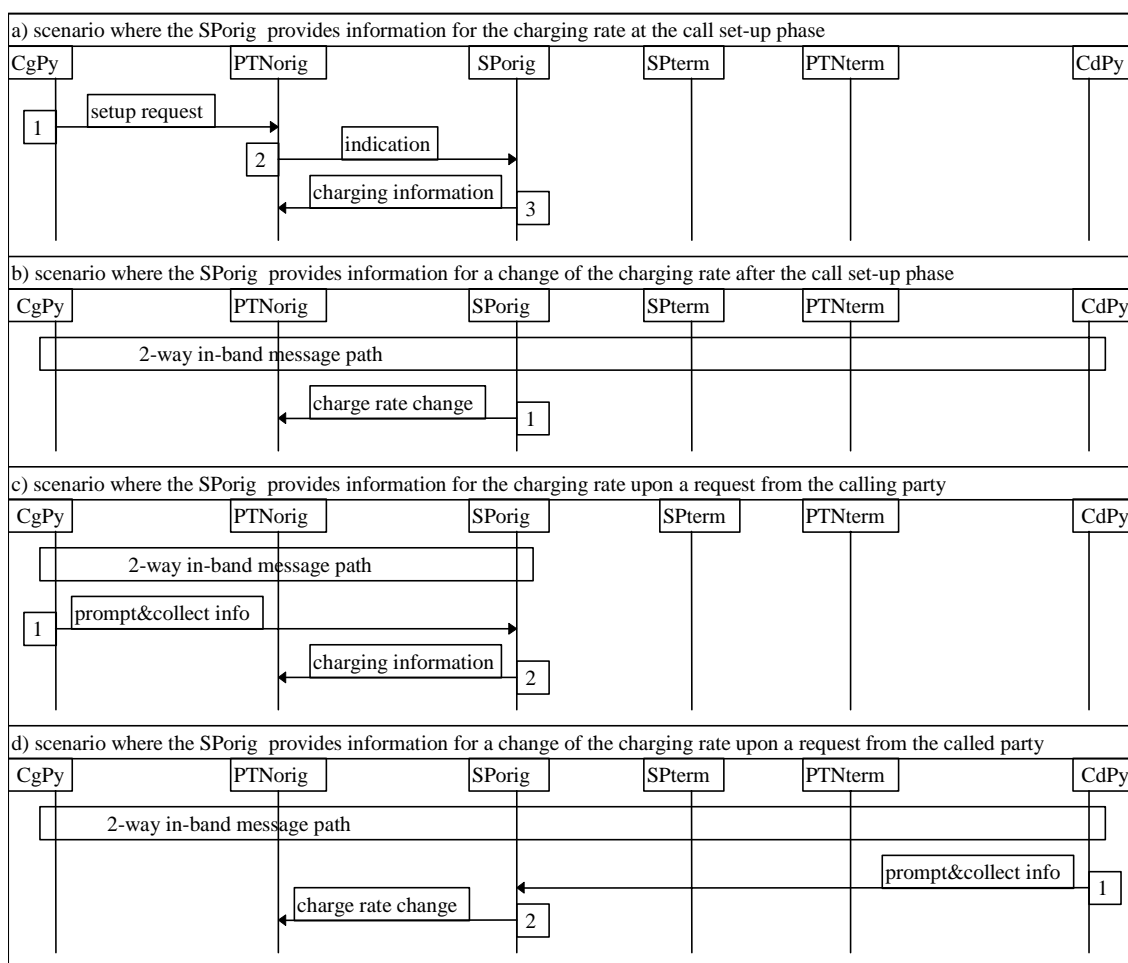

Figure 22: Changes in the charging rate of a call

6.6 Traffic-related capabilities

6.6.1 Event traceability

The SP needs the ability to perform event traceability with the PTN, which should produce relevant call tracing data.

6.6.1.1 Priority

The priority of this requirement is medium.

6.6.1.2 Example of usage

The SP needs event traceability in order to enable the combination of all the data of each call in off-line processing, e.g. for billing purposes or fault analysis.

Event traceability may also be useful for fraud prevention in the case of a CR interface, so that the PTNO can identify that a call entering the network was originally originated within the same network.

6.6.1.3 Technical aspects

The utilization of a global call reference numbers would facilitate event traceability.

6.6.1.4 Information flow chart

In the message sequence scenario a) in figure 23, call detail data is exchanged between the PTNorig and the related SPorig. In the second scenario b), call detail data is exchanged between the terminating PTN and the related SPterm.

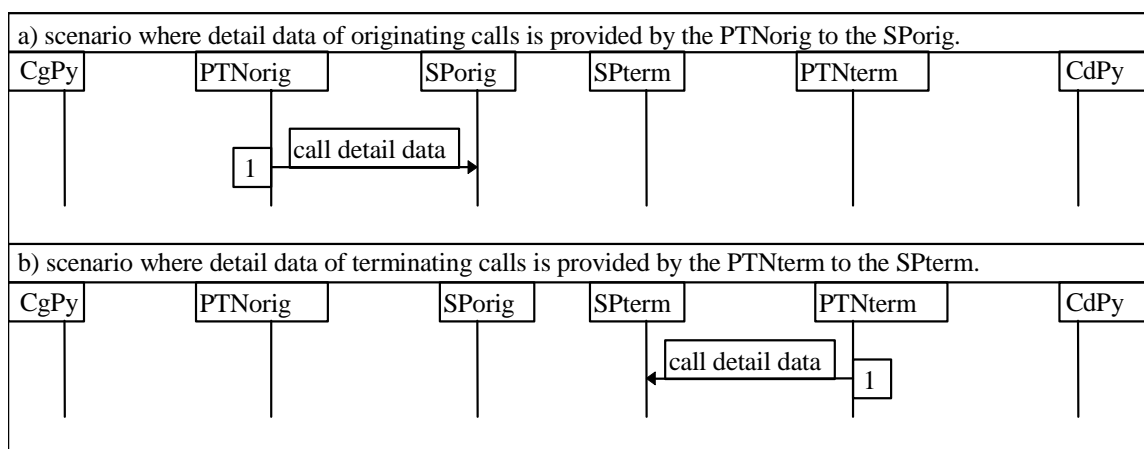

Figure 23: Event traceability

6.6.2 Traffic control capabilities

The SP needs the ability to control the signalling and/or call traffic between the SP's equipment and the PTN.

6.6.2.1 Priority

The priority of this requirement is medium.

6.6.2.2 Example of usage

Traffic control capabilities may also be needed at the time of overload or congestion.

6.6.2.3 Technical aspects

In order to ensure a sufficient quality of service for the carried traffic, the SP and PTNO may desire that the traffic offered to the SP's equipment does not exceed the dimensioned capacity of the related connection or the SP's equipment. Therefore, capabilities may be needed by both the SP and PTNO to control the signalling and call traffic between the SP's equipment and the PTN.

6.6.2.4 Information flow chart

In the message sequence scenario a) in figure 24, traffic data is exchanged between the PTNorig and the related SPorig. In the second scenario b), traffic data is exchanged between the PTNterm and the related SPterm.

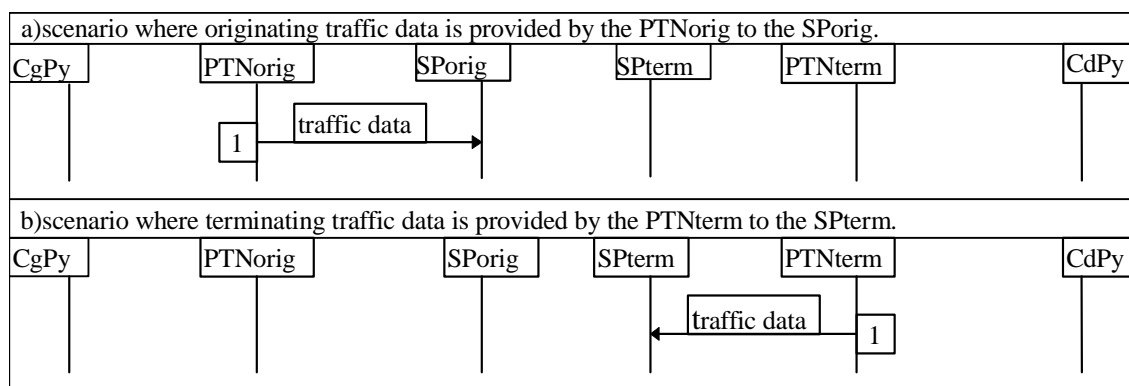

Figure 24: Traffic control capabilities

6.6.3 Avoidance of the cyclical routing of a call

The SP needs the ability to detect and stop cyclical routing of a call between the PTN and the SP's equipment.

6.6.3.1 Priority

The priority of this requirement is medium.

6.6.3.2 Example of usage

During the connection set-up phase of any single call, the call could be forwarded several times incorporating multiple number translations. In some situations, repeated call forwarding may cause undesirable cyclical routing of the call.

6.6.3.3 Technical aspects

To avoid undesirable cyclical routing, one alternative is that sufficient data is associated with the call (e.g. a "hop" counter of the forwarding operations performed).

6.6.3.4 Information flow chart

Void.

7 Non-circuit-related functional requirements

7.1 Call connection scenarios

In this clause, only the NCR requirements of the SPA are described. Technical aspects (which further elaborate the high-level description), examples of usage and information flow charts are presented. Furthermore, the priority (from the SP's point of view) is presented.

For calls from a calling party (CgPy) in the originating PTN (PTNorig) to a called party (CdPy) in the terminating PTN (PTNterm), in which both PTNs and SPs are involved, various call connection scenarios are possible. Figure 25 visualizes two examples of a call connection scenario in the NCR case from the viewpoint of the requirements of the SPs of the originating- and terminating-call-related services, called SPorig and SPterm, respectively.

Scenario C is an example of a call in which SPorig is involved. In this scenario, the signalling in the control plane is forwarded from the PTNorig to SPorig which provides a service to the call. Then, the signalling in the control plane is returned to the PTNorig, which forwards the call to the PTNterm, eventually via a transit network (PTNtran), in which the call is terminated at the called party's (CdPy) line.

Scenario D is an example of a call in which SPorig is involved. In this scenario, the signalling in the control plane is forwarded from the PTNorig to SPorig which provides a service to the call. The signalling in the control plane is then returned to the PTNorig, which forwards the call to the PTNterm, eventually via a transit network (PTNtran). Then, the control plane signalling is forwarded from the PTNterm to SPterm which provides a service to the call. The signalling in the control plane is then returned to the PTNterm, in which the call is terminated at the called party's (CdPy) line.

Note that scenario C and D in figure 25 are just examples of the possible call connection scenarios.

Note that an SP organization could perform both the roles of SPorig and SPterm.

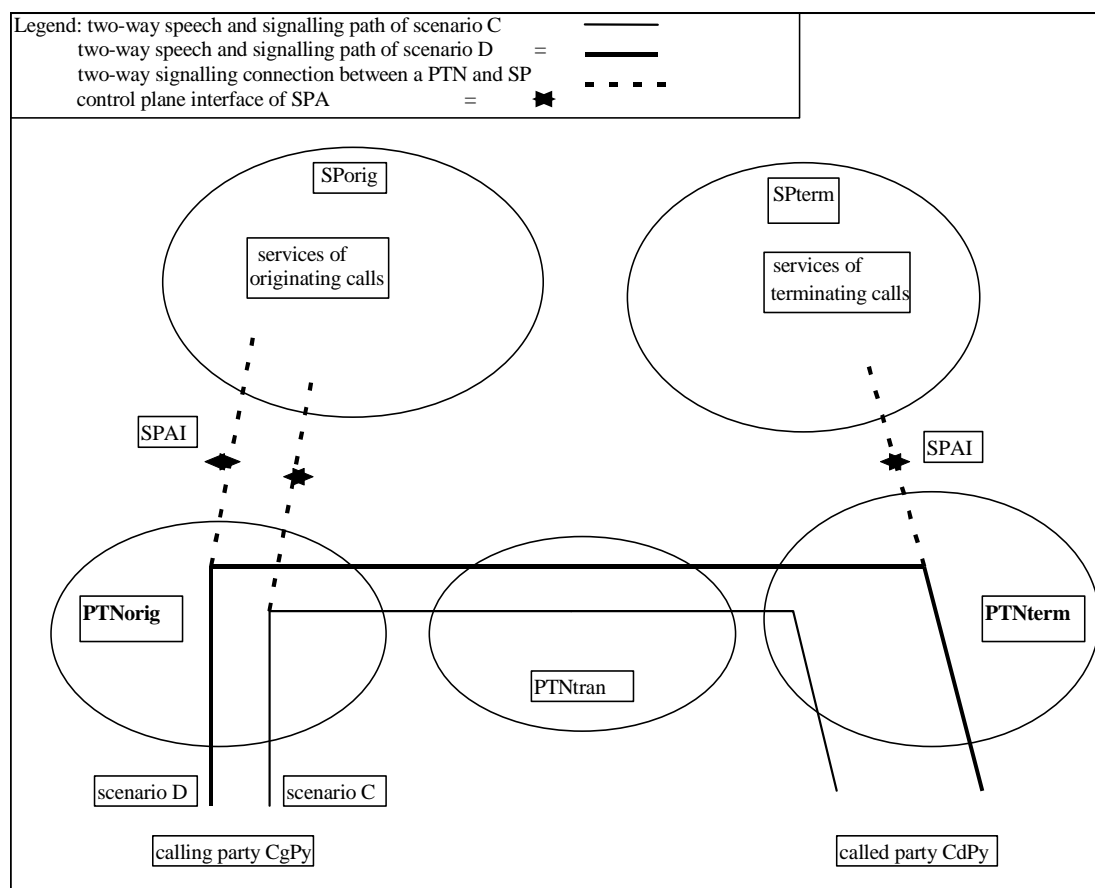

Figure 25: Examples of call connection scenarios in the case of a non-circuit-related SPA

In this clause, those requirements that are not relevant from the NCR viewpoint are marked as "void".

7.2 Calling party information handling capabilities

7.2.1 Reception of the calling line identity

The SP needs to receive the calling line identity (CLI) from the PTN with a call indication, if the CLI is available in the PTN. If the calling party is using the services of the SP and the national regulations and/or legislation allows it, this requirement also applies to a CLI marked as "presentation-restricted". All the indicators associated with the CLI need also to be delivered.

7.2.1.1 Priority

The priority of this requirement is high.

7.2.1.2 Example of usage

The SP needs the CLI, including all related indicators, in order to produce services such as origin dependent routing. Other services depending on CLI for user verification, such as message retrieval from personal Voice Mail services, also require CLI with all indicators.

7.2.1.3 Technical aspects

Refer to clause 6.2.1.3.

7.2.1.4 Information flow chart

A message sequence scenario is presented in figure 26 from the viewpoint of the SPorig. The corresponding scenario is similar, when the SPterm receives the call indication from the PTNterm.

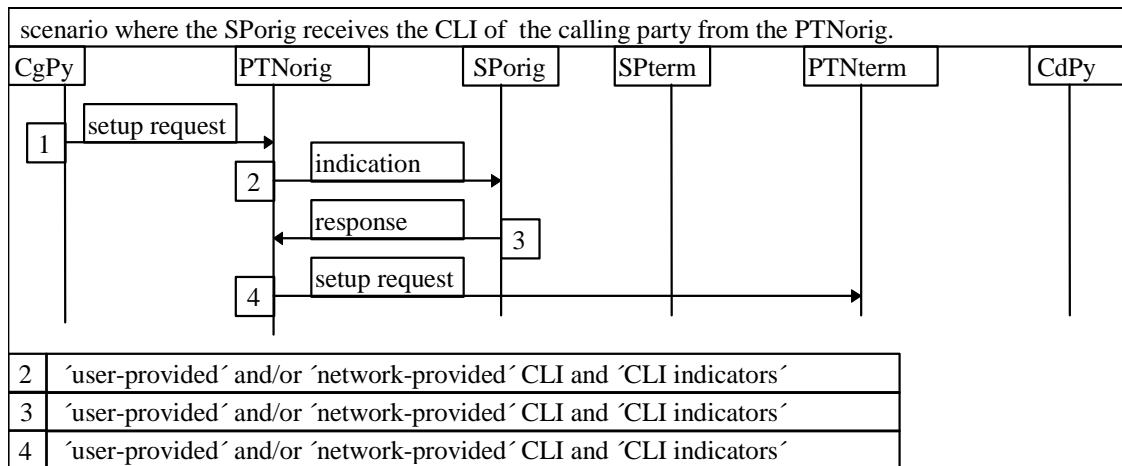

Figure 26: Reception of the calling line identity

7.2.2 Presentation of the complete CLI information to the PTN

The SP needs the ability to present all the CLI information about the calling party to the PTN. This includes the original CLI together with the related status information, as well as all the relevant indicators of the category of the call.

7.2.2.1 Priority

The priority of this requirement is high.

7.2.2.2 Example of usage

Due to the fact that other SPs may also be involved in the call set-up procedure, e.g. in the case of "service chaining", every SP and PTNO needs to be able to relay all the received information about the calling party, including the relevant indicators of the category of the call (e.g. "payphone call", "operator-initiated call"). However, for certain services, the SP may have to change part of this information, e.g. the redirection number and redirection indicator.

7.2.2.3 Technical aspects

This requirement does not imply that the SP should always forward the received information unchanged.

7.2.2.4 Information flow chart

A message sequence scenario is presented in figure 27 from the viewpoint of the SPorig. The corresponding scenario is similar, when the SPterm receives the call indication from the PTNterm returning a response to the same network or re-routing it directly to another network.

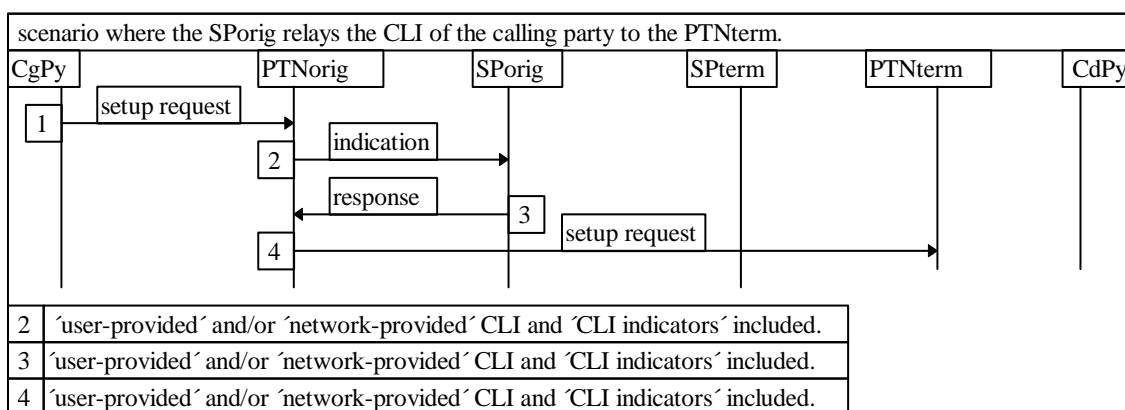

Figure 27: Presentation of the complete CLI information to the PTN

7.2.3 Addition or substitution of a calling line identity

The SP needs the ability to add or substitute the User Provided CLI to the CLI information of a call when passing it forward.

7.2.3.1 Priority

The priority of this requirement is high.

7.2.3.2 Example of usage

When the SP passes a call to the terminating PTN, an additional or alternative number may need to be delivered as a "user-provided, not screened" CLI to inform the called party of the SP or service involved.

7.2.3.3 Technical aspects

The "network provided" or "user provided, verified and passed" CLI of the calling party in the network provided CLI field shall not be replaced, but accompanied by the CLI information provided by the SP, because the original CLI also needs to be delivered.

7.2.3.4 Information flow chart

A message sequence scenario is presented in figure 28 from the viewpoint of the SPorig. The corresponding scenario is similar, when the SPterm receives the indication of a call from the PTNterm returning a response.

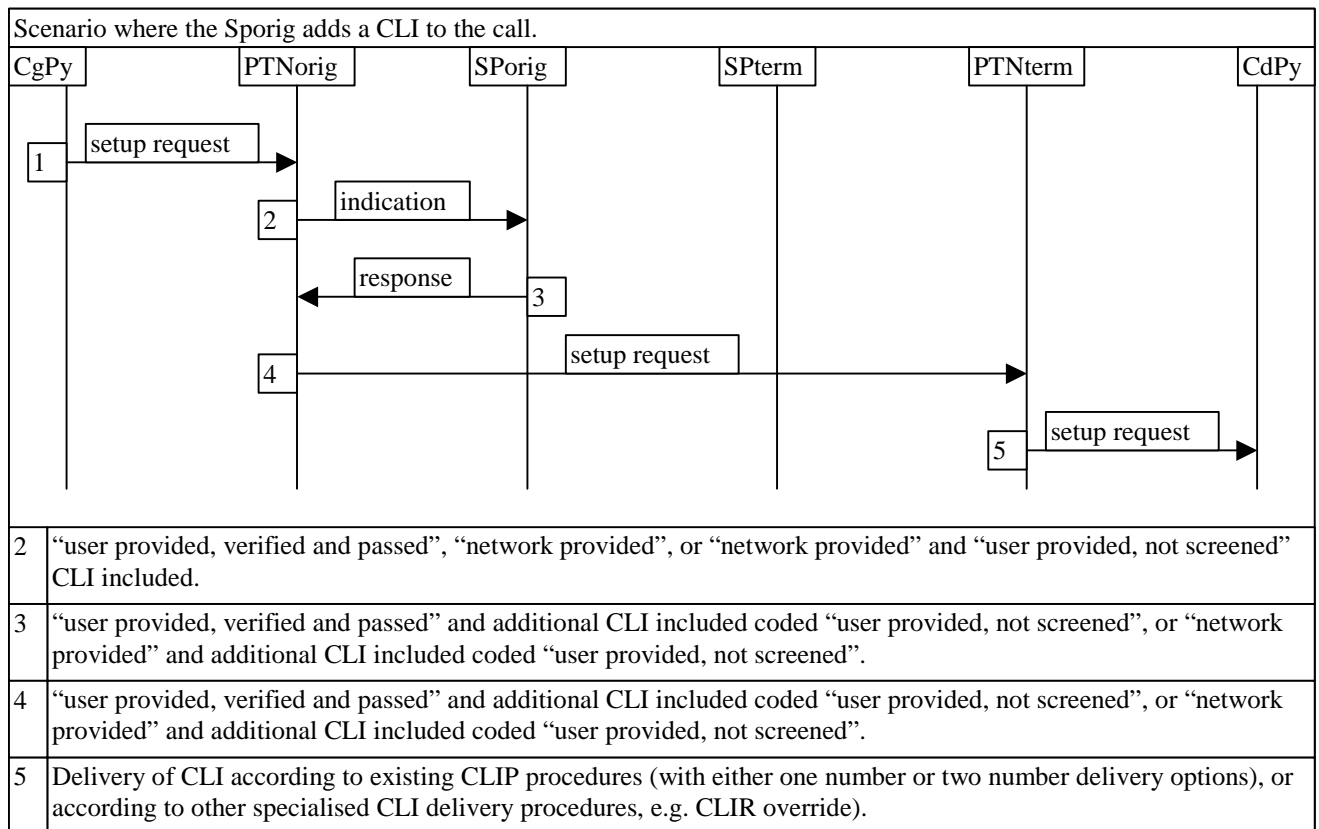

Figure 28: Addition of CLI information to a call

7.2.4 Provision of CLI information to an SP-initiated call

The SP needs the ability to provide CLI information to an SP-initiated call that the SP instructs to be originated by the PTN.

7.2.4.1 Priority

The priority of this requirement is high.

7.2.4.2 Example of usage

In a situation where the SP is providing a service where it places outbound IVR calls to debtors on behalf of a debt collection agency, the SP would want to populate the CLI field with the CLI of the debt collection agency.

7.2.4.3 Technical aspects

The CLI provided by the SP needs to be delivered as a "network-provided" CLI. In addition, the SP needs to be able to provide another service-specific number to be delivered as a "user-provided, not screened" CLI.

7.2.4.4 Information flow chart

A message sequence scenario is presented in figure 29 from the viewpoint of the SPorig that sends a call request to the PTNorig.

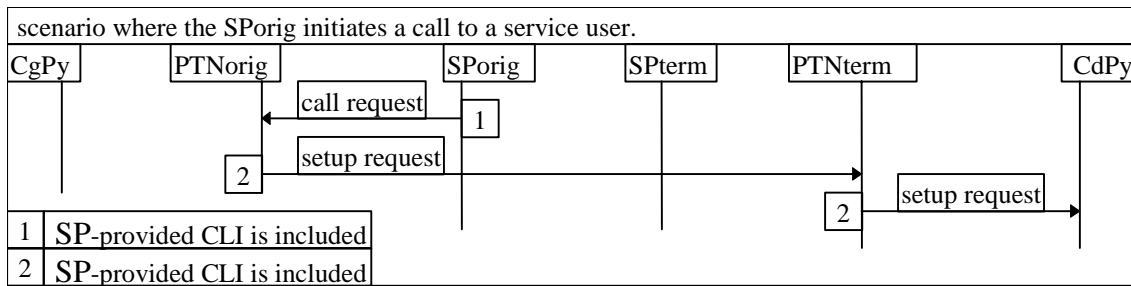

Figure 29: Provision of CLI information to an SP-initiated call

7.2.5 Relaying of the malicious call identification data of a received call

Void.

7.3 Basic call set-up and clear-down capabilities

7.3.1 Return speech path connection from the terminating PTN to the calling party

The SP needs the ability to request the through-connection of a backward in-band message path to the calling party immediately upon the arrival of a confirmation of the call set-up. There should be a mechanism for the support of charging between the PTNO and the SP.

7.3.1.1 Priority

The priority of this requirement is high.

7.3.1.2 Example of usage

If the user of a call diversion service has specified a cellular phone as the terminating address, and the cellular phone happens to be out of radio coverage, the terminating PTN plays an in-band message, in order to inform the calling party that the called party is not reachable.

7.3.1.3 Technical aspects

Refer to clause 6.3.1.3.

7.3.1.4 Information flow chart

A message sequence scenario is presented in figure 30 from the viewpoint of both the SPorig and SPterm.

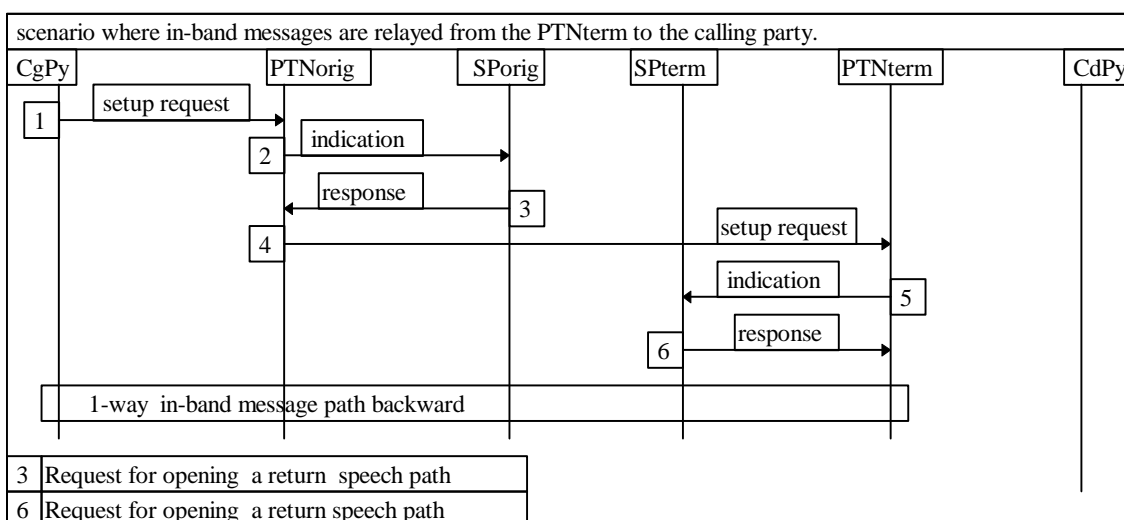

Figure 30: Return speech path connection from the PTNterm to the calling party

7.3.2 Routing of an originating or incoming call from the PTN to the SP

Void.

7.3.3 Indication of an originating or incoming call from the PTN to the SP

On defined criteria, the SP needs from the PTN the indication of an originating or incoming call from an SP's service user, e.g. based on the dialled digits or CLI. There should also be a mechanism for the support of charging between the PTNO and the SP.

7.3.3.1 Priority

The priority of this requirement is high.

7.3.3.2 Example of usage

"Freephone" and "selective call barring" services are examples.

7.3.3.3 Technical aspects

An indication of an originating call may be routed to the SP on defined criteria to enable the SP to control further routing of the call, e.g. via a translation of the dialled number. Examples of these criteria are:

- a call dialled with a prefix that identifies the SP;
- a call dialled without an "escape" prefix;
- a call with the CLI of the calling party in a specific number range (not applicable in the case of number portability);
- a call made by a specific calling party (i.e. CLI);
- a call made at a specific NTP; or
- a call directed to a specific destination and subdestination.

Interactions between the above-mentioned criteria and the existing carrier selection and carrier pre-selection criteria may occur.

The PTN needs to send an indication to the SP after the calling party has dialled a number. After the dialled digits are analysed, an indication is sent to the SP's equipment containing data, such as the dialled digits and the identity of the calling party's line (i.e. CLI).

After receiving the indication of the call from the PTN, the SP is able to give instructions on the destination and routing of the call, e.g. in the form of a new destination number and possibly a set of digits for carrier selection.

The dialled digits can represent either a normal called party number, or an indication (e.g. a prefix or a short code), which may be used for the selection of a SP directly or which can prompt for further digits for the selection.

Access to the emergency services shall be considered. The network may have to trap specific calls, e.g. emergency calls, instead of indicating these calls to the SP.

The sending of a query to the SP in case of detection of an end user's off-hook may require special arrangements to handle emergency calls.

7.3.3.4 Information flow chart

In the first message sequence scenario a) in figure 31, the PTNorig sends only an indication to the SP. In scenario b), the SPorig returns a response to the PTNorig.

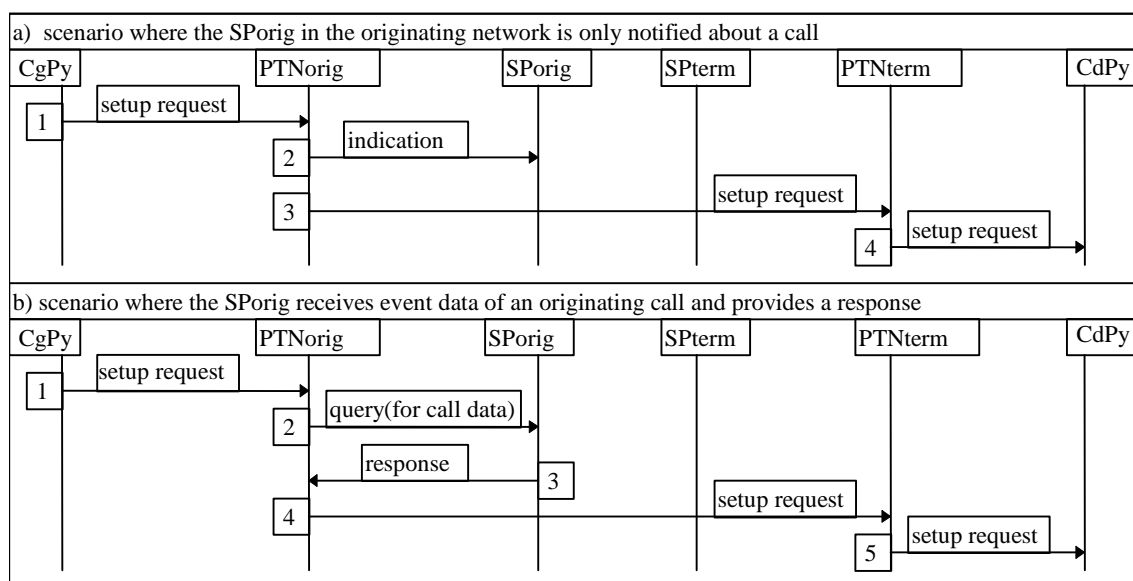

Figure 31: Indication of an originating or incoming call from the PTN to the SP

7.3.4 Routing of a terminating call from the PTN to the SP

Void.

7.3.5 Indication of a terminating call from the PTN to the SP

On defined criteria, the SP needs to receive from the PTN the indication of a terminating call of the SP's service user, e.g. based on the dialled digits or CLI.

7.3.5.1 Priority

The priority of this requirement is high.

7.3.5.2 Example of usage

"Distinctive ringing" and "call screening" services are examples.

7.3.5.3 Technical aspects

Depending on the type of the service, an indication of a terminating call may need to be sent by the terminating PTN to the SP on defined criteria, e.g. when the called party is a service user of the SP. An indication is needed on the basis of defined criteria, e.g. in the case of

- a call with the dialled number in a specific number range; or
- a call to a specific dialled number;
- a call that is destined to a specific number and is unsuccessful for some reason;
- a call that is unsuccessful for some reason with the dialled number being in a specific number range;
- a call of a particular type destined to an individual number or number block (e.g. long-distance calls or international calls).

After receiving the indication of a call, including the routing number, the SP can provide the PTN a new number, which may include the actual destination number preceded by a set of digits for carrier selection purposes. This new number provided by the SP shall comply with the numbering plan.

The requirement is only applicable, when the routing number uniquely identifies the terminating line (e.g. in the case of an ordinary geographic number).

7.3.5.4 Information flow chart

In the message sequence scenario a) in figure 32, the SPterm receives an indication of a terminating call solely for notification purposes. In the second scenario b), the SPterm returns a response to the PTNterm for further control of the call.

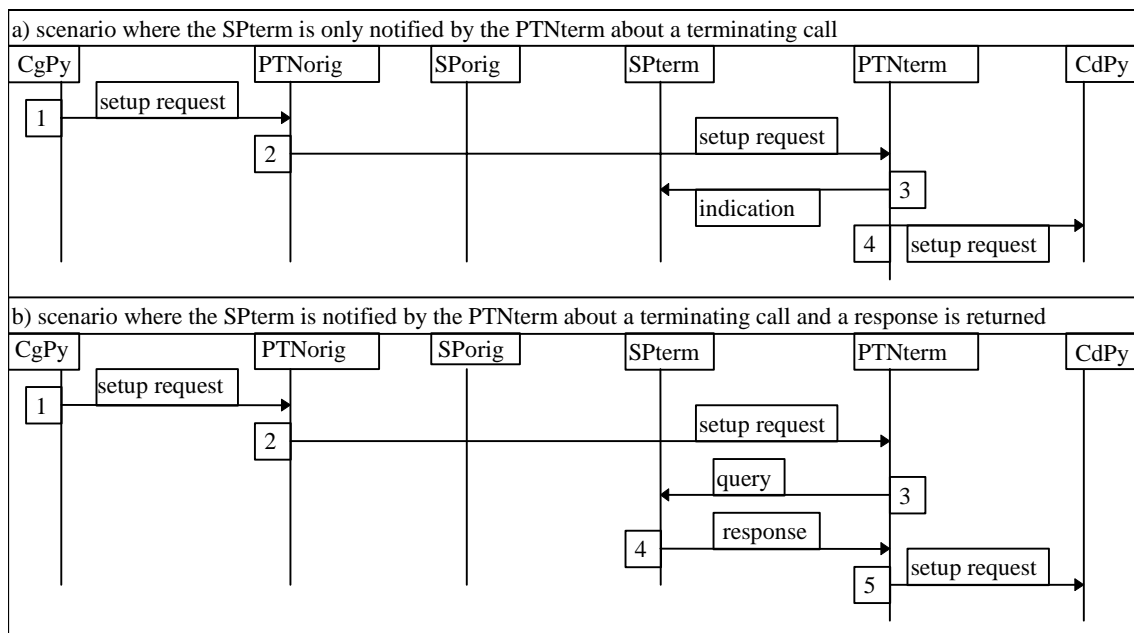

Figure 32: Indication of a terminating call from the PTN to the SP

7.3.6 Reception of an indication of the cause of an unsuccessful call

On defined criteria, the SP needs to receive from the terminating PTN the indication of an unsuccessful call and the cause value, i.e. either when an indication other than "alerting tone" is returned to the calling party, or when a "no reply" situation occurs. After receiving this indication, the SP needs the ability to send a response to the PTN for further control of the call. The indication is needed on the basis of defined call unsuccessful cause values, such as "called party busy" or "no reply". There should be a mechanism for the support of charging between the PTNO and the SP.

7.3.6.1 Priority

The priority of this requirement is high.

7.3.6.2 Example of usage

An instruction of the SP to the PTN to route a call to a voice messaging system in the event that the called party is busy can be given as an example.

7.3.6.3 Technical aspects

Refer to clause 6.3.6.3.

7.3.6.4 Information flow chart

In figure 33, a message sequence scenario is presented from the viewpoint of the SPorig in the presence of a speech path connection, assuming that the SPorig is connected to only the PTNorig and the call is unsuccessful due to the called party being busy (scenario a) or rejecting the call (scenario b).

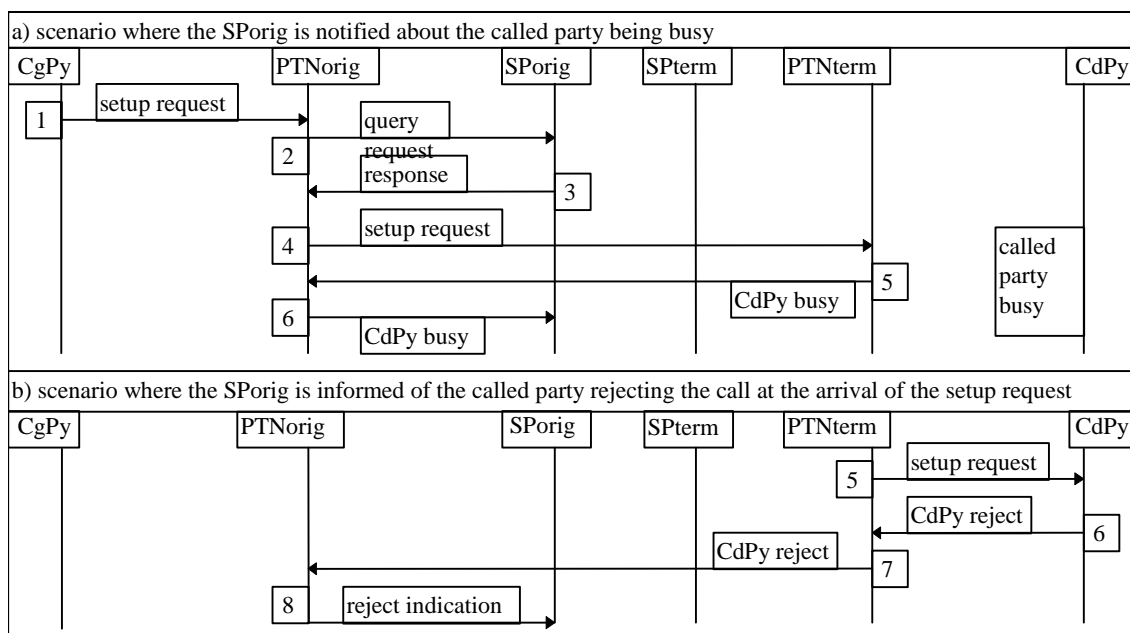

Figure 33: Reception of an indication of the cause of an unsuccessful call

7.3.7 Provision of information for the destination and routing of a call

The SP needs the ability to provide call destination and routing information. If the SP is not connected to the speech path, the SP needs to receive the indication of a call. The SP also needs the ability to return a message to the PTN for controlling the destination and routing of the call. There should be a mechanism for the support of charging between the PTNO and the SP.

7.3.7.1 Priority

The priority of this requirement is high.

7.3.7.2 Example of usage

In the connection of many services, the SP needs to provide an actual routing number to the PTN on the basis of the dialled number.

7.3.7.3 Technical aspects

The PTN can send a query to the SP for instructions regarding the destination and routing of the call.

7.3.7.4 Information flow chart

The PTN sends a query to the SPorig, as described in figure 34.

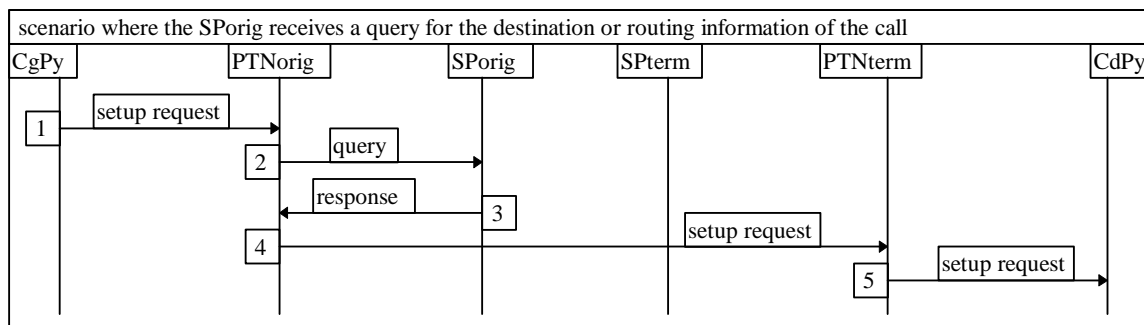

Figure 34: Provision of information for the destination and routing of a call

7.3.8 Call drop-back

Void.

7.3.9 User interaction without service charging of the end user

Void.

7.3.10 Reception of the originally dialled digits

The SP needs the ability to receive all originally dialled digits from the PTN.

7.3.10.1 Priority

The priority of this requirement is low.

7.3.10.2 Example of usage

The SP needs to know the original number that was dialled, e.g. in the case of a "freephone" or "follow-me" number.

7.3.10.3 Technical aspects

This requirement is also valid when the dialled number has been translated before the SP receives an indication of the call.

If the originating PTN has translated the dialled number and the SP requires the originally dialled digits, then the SP needs both the routing number and all originally dialled digits.

7.3.10.4 Information flow chart

The flowcharts in figure 35 describe message sequence scenarios in a situation where the call itself is not connected to the SP's equipment. Since the SPorig or SPterm is not connected to the speech path, the original dialled number is expected to be available in the indication of the call that is provided by the PTN.

The first flowchart a) in figure 35 presents a message sequence scenario from the viewpoint of the SPorig and SPterm when the dialled number is not translated before the terminating network receives the call. The second flowchart b) presents the corresponding scenario assuming that the SPorig performs a number translation.

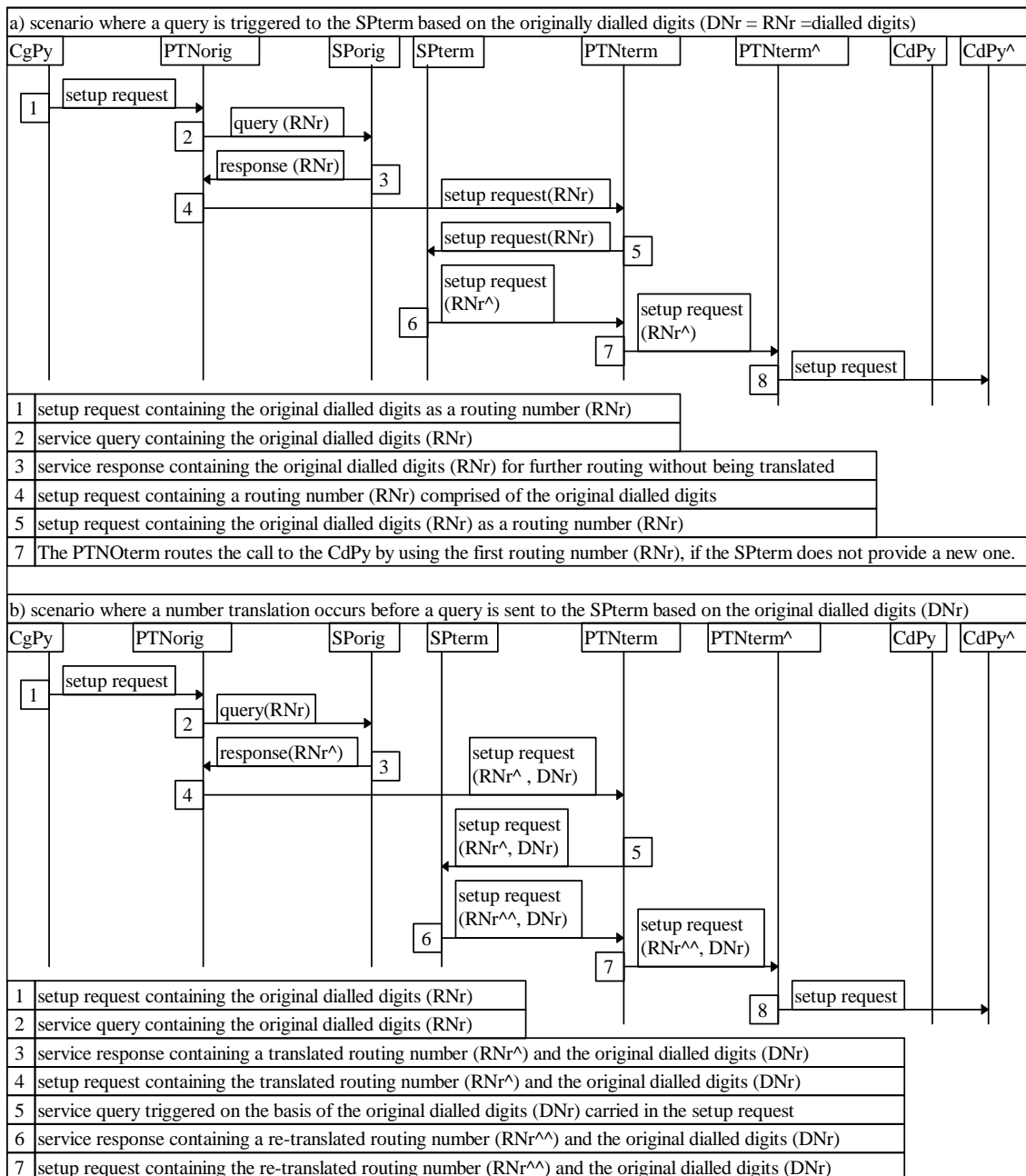

Figure 35: Reception of the originally dialled digits

7.3.11 Disconnection of a call in progress

The SP needs the ability to instruct the PTN to disconnect a call in progress, if either the calling or called party is a service user of the SP.

7.3.11.1 Priority

The priority of this requirement is medium.

7.3.11.2 Example of usage

Calling card running out of credit is an example.

7.3.11.3 Technical aspects

The SP needs the ability to request the PTN to disconnect a call in progress, if either the calling or called party is a service user of the SP.

7.3.11.4 Information flow chart

The first flowchart a) in figure 36 presents a message sequence scenario from the viewpoint of the SPorig. The second flowchart b) presents the corresponding scenario assuming that the SPterm disconnects the call.

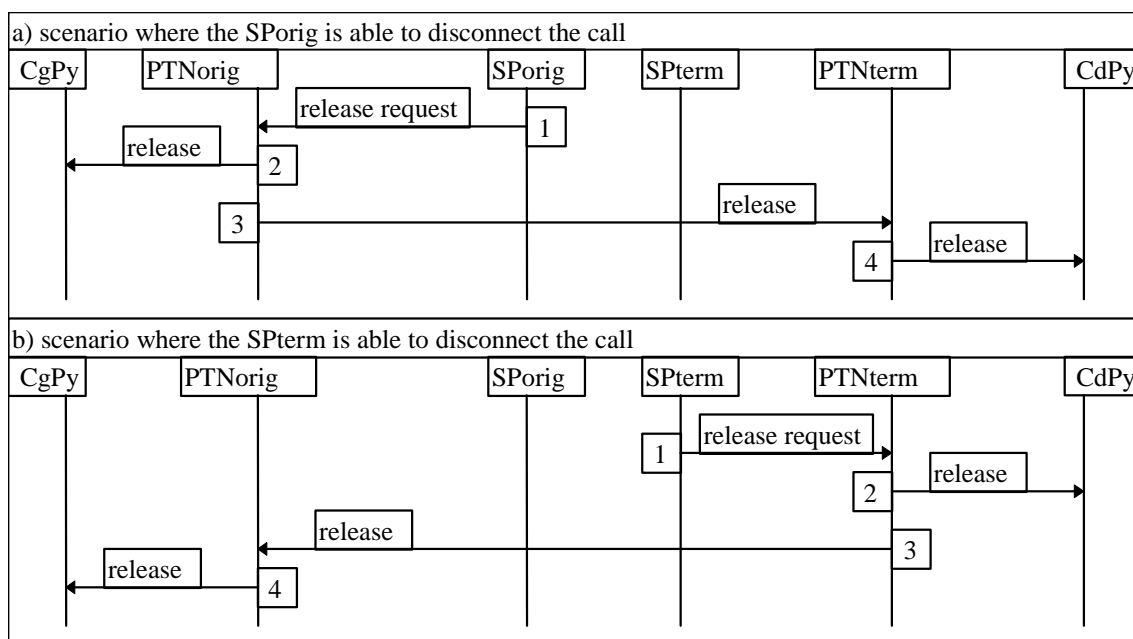

Figure 36: Disconnection of a call in progress

7.3.12 Connection of a call to an interactive voice response unit in the PTN

The SP needs the ability to instruct the PTN to connect a call to an interactive voice response (IVR) unit in the PTN.

7.3.12.1 Priority

The priority of this requirement is medium.

7.3.12.2 Example of usage

In order to enable the SP to offer interactive voice response (IVR) services by means of e.g. a service node, a signalling connection carrying the network signalling information from the SP to the PTN is needed.

7.3.12.3 Technical aspects

Both a speech path (e.g. UNI or NNI) and the correlated control connection (e.g. INAP) may be needed to carry the required network signalling information between the SP and PTN.

The location of the IVR unit (remote SP's premises, PTNO premises or third party premises) does not have impact on the requirement.

7.3.12.4 Information flow chart

The flowchart of figure 37 presents a message sequence scenario where the SPorig interactively controls the playing of recorded messages and collection of menu-based responses via an IVR unit in the PTN.

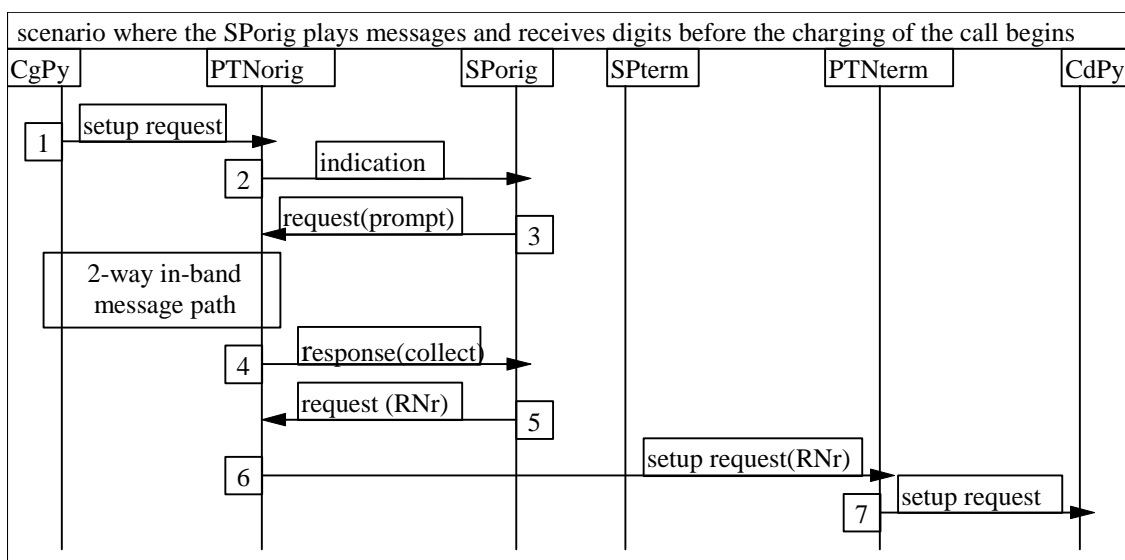

Figure 37: Connection of a call to an interactive voice response unit in the PTN

7.3.13 Alternate routing of a call or the indication of a call to another "point of presence" of the SP

The SP needs the ability to instruct the PTN to route calls or the indications of calls to another "point of presence" of the SP, if the first "point of presence" is not reachable.

7.3.13.1 Priority

The priority of this requirement is medium.

7.3.13.2 Example of usage

For reliability or capacity reasons, the SP may have several "points of presence", i.e. network interconnection points between the SP and PTN. The capability to instruct a PTN about the configuration of the routing of traffic to "points of presence" can be useful in case a particular "point of presence" is out of service e.g. in case of maintenance.

7.3.13.3 Technical aspects

This alternate routing is not needed on a call by call basis.

7.3.13.4 Information flow chart

The flowcharts a) in figure 38 present a message sequence scenario where the SPorig informs the PTNorig about another "point of presence". Scenario b) presents the corresponding scenario from the viewpoint of the SPterm.

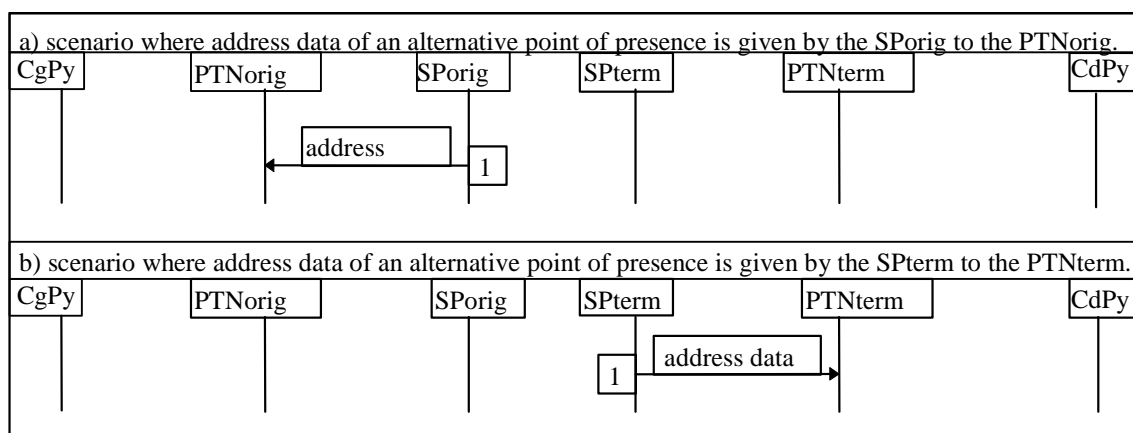

Figure 38: Alternate routing of a call or the indication of a call to another "point of presence" of the SP

7.4 Supplementary call and data processing capabilities

7.4.1 Interrogation of a network termination point for data delivery

The SP needs the ability to send data to and to receive data from the NTP of a service user without an alerting signal. There has to be a mechanism for the support of charging between the PTNO and the SP.

7.4.1.1 Priority

The priority of this requirement is medium.

7.4.1.2 Example of usage

"Remote meter reading" service is an example.

7.4.1.3 Technical aspects

The required capability is also called "Collection of Telemetry". In the longer term, "collection of telemetry" could be possible without setting up a call. Note that different solutions may be applicable to the ISDN users. One solution could be that the NTP would have a capability to recognize the SP's CLI in the case of a terminating call and the CPE would be able to answer the call without any user intervention.

If supported by the CPE, the SP should be able to interrogate and collect meter readings etc. via D-channel signalling and other similar NCR methods.

7.4.1.4 Information flow chart

The flowchart in figure 39 presents a message sequence scenario from the viewpoint of the SPterm, because the called party is located in the PTNterm and the SP in that network is called SPterm.

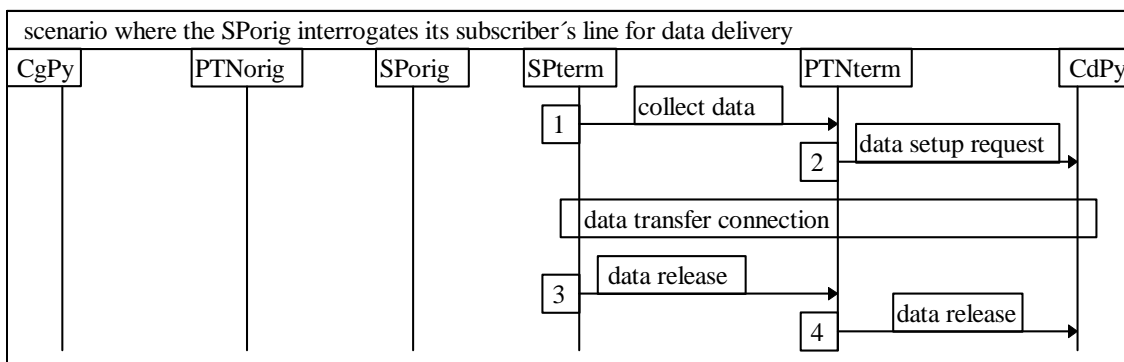

Figure 39: Interrogation of a network termination point for data delivery

7.4.2 Overriding of the "incoming call barring" supplementary service

The SP needs the ability to request the PTN to override any "incoming call barring" supplementary service activated on one of the SP's service users' lines, provided this is allowed by bilateral agreements between the SP and the provider of the "incoming call barring" supplementary service.

7.4.2.1 Priority

The priority of this requirement is high.

7.4.2.2 Example of usage

SP management access to a "premium rate" service line, e.g. in the case of entertainment services, is an example.

7.4.2.3 Technical aspects

"Incoming call barring" and similar supplementary services are often used to protect the underlying phone numbers of special service subscribers (e.g. premium rate numbers) against direct access and thus fraud. Thus the dialled number has to be converted into a special routing number to pass through this call barring, and a special indicator is applied in the call instruction. Special overriding of this call barring may be achieved by the use of a special indicator. Calls where these two indicators match may override this Call Barring. Calls without the matching of these indicators match may be rejected.

7.4.2.4 Information flow chart

The flowchart in figure 40 presents a message sequence scenario where the SPterm requests the PTNterm to override the "incoming call barring" supplementary service of one of its subscribers.

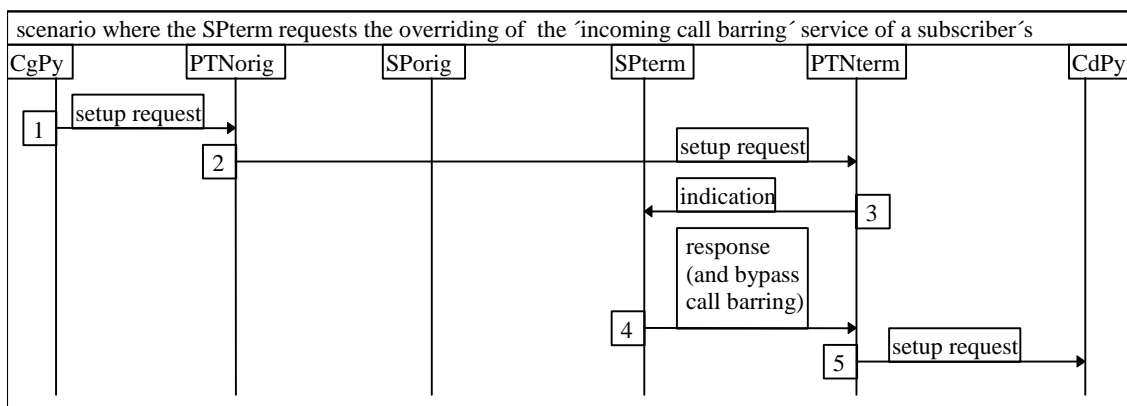

Figure 40: Overriding of the "incoming call barring" supplementary service

7.4.3 Bypassing of the "call diversion" supplementary service

The SP needs the ability to request the PTN to bypass any "call diversion" supplementary service on one of the SP's service users' lines, provided this is allowed by bilateral agreements between the SP and the provider of the "call diversion" supplementary service.

7.4.3.1 Priority

The priority of this requirement is low.

7.4.3.2 Example of usage

An example is the case where a service subscriber has diverted all calls to an answering service, and the SP needs to bypass the call diversion for a wake-up call.

7.4.3.3 Technical aspects

Void.

7.4.3.4 Information flow chart

The flowchart in figure 41 presents a message sequence scenario where the SPterm requests the PTNterm to bypass the "call diversion" supplementary service of one of its subscribers.

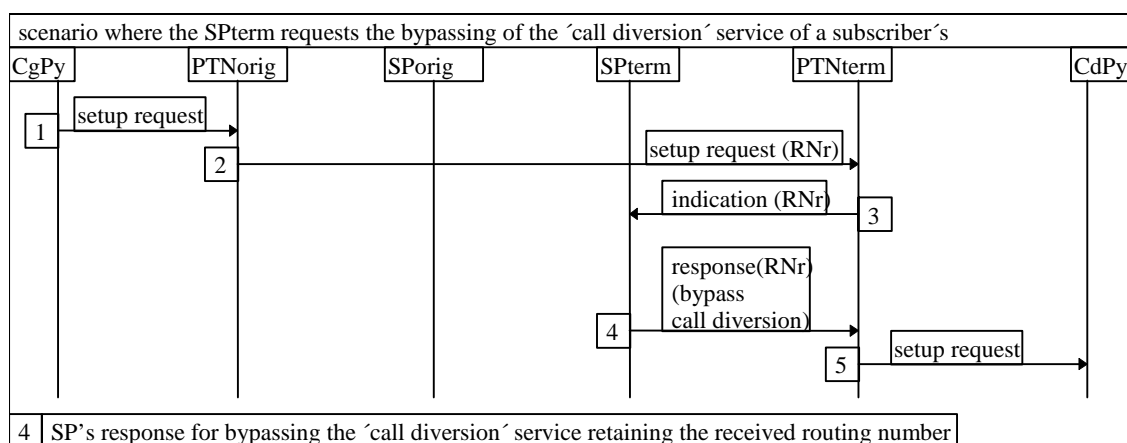

Figure 41: Bypassing of the "call diversion" supplementary service

7.4.4 Message waiting indication

The SP needs the ability to activate and deactivate a message waiting indication to an SP service user's line.

7.4.4.1 Priority

The priority of this requirement is high.

7.4.4.2 Example of usage

"Notification of the arrival of an e-mail message" service is an example.

7.4.4.3 Technical aspects

Void.

7.4.4.4 Information flow chart

The flowchart in figure 42 presents the related message sequence scenarios from the viewpoint of the SPterm, because the message waiting indication is a service of the called party.

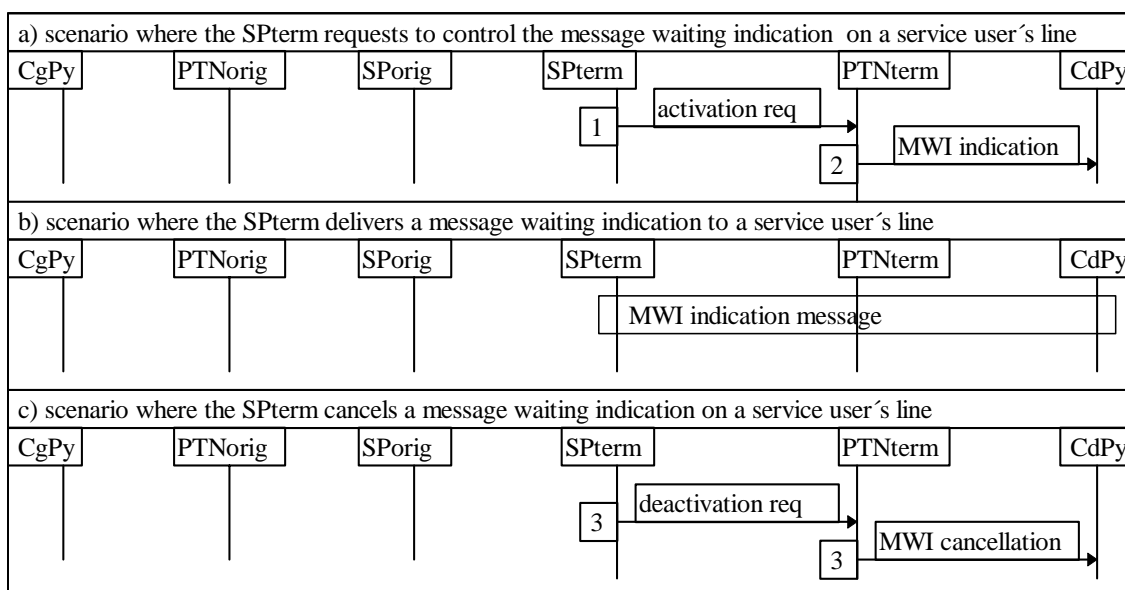

Figure 42: Message waiting indication

7.5 Charging-related capabilities

7.5.1 Changes in the charging rate of a call

The SP needs the ability to instruct the PTN to change the charging rate of a call, applied to the SP's service user, during the call set-up phase and the duration of the call.

7.5.1.1 Priority

The priority of this requirement is high.

7.5.1.2 Example of usage

A service example is a remotely located menu-based selection of services where the charge rate depends on the choice made by the calling party.

7.5.1.3 Technical aspects

The request to the SP to change the charging rate, may be invoked by an external event, possibly after a request from either the calling or called party. Normally, the call charge rate is determined during the call set-up phase, based on the number dialled, time of day, day of week etc. In addition, INAP CS-1 allows the SP to control the charging during the active state of a call in a pre-defined model. To control the charging flexibly in such a situation, the remote unit (CPE of the called party or the SP) needs the ability to send a message to the SP's service control system, for authorization and further processing.

7.5.1.4 Information flow chart

The flowchart in figure 43 presents a message sequence scenario where the SPorig provides charging information to the PTNorig.

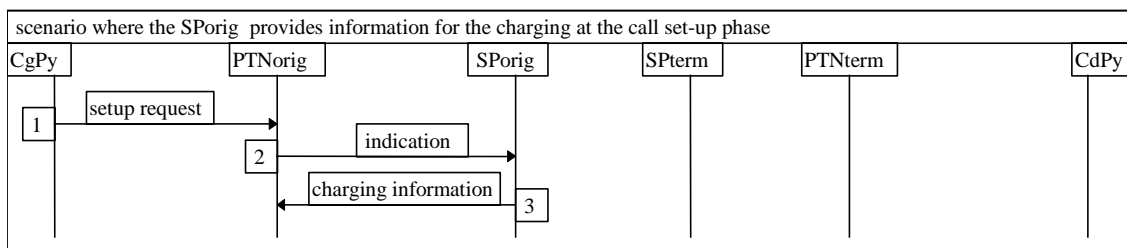

Figure 43: Changes in the charging rate of a call

7.6 Traffic-related capabilities

7.6.1 Event traceability

The SP needs the ability to perform event traceability with the PTN, which should produce relevant call tracing data.

7.6.1.1 Priority

The priority of this requirement is medium.

7.6.1.2 Example of usage

The SP needs event traceability in order to enable the combination of all the data of each call in off-line processing, e.g. for billing purposes or fault analysis.

7.6.1.3 Technical aspects

Event traceability may also be useful for fraud prevention in the case of a CR interface, so that the PTNO can identify that a call entering the network was originally originated within the same network.

The utilization of global call reference numbers would facilitate event traceability.

7.6.1.4 Information flow chart

In the message sequence scenario a) in figure 44, call detail data is exchanged between the originating PTN and the related SPorig. In the second scenario b), call detail data is exchanged between the PTNterm and the related SPterm.

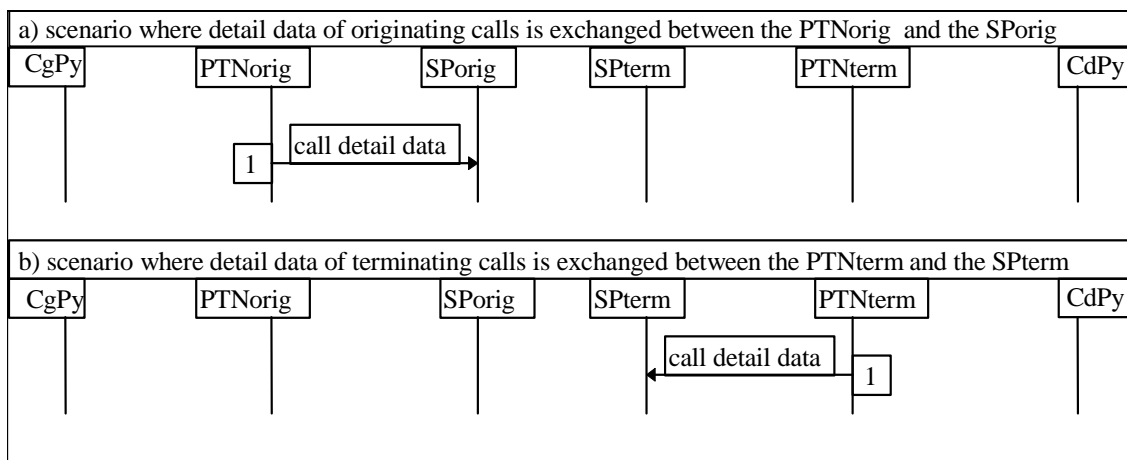

Figure 44: Event traceability

7.6.2 Traffic control capabilities

The SP needs the ability to control the signalling traffic between the SP's equipment and the PTN.

7.6.2.1 Priority

The priority of this requirement is medium.

7.6.2.2 Example of usage

Traffic control capabilities may be needed at the time of overload or congestion.

7.6.2.3 Technical aspects

In order to ensure a sufficient quality of service for the call/signalling traffic, the SP and PTNO may desire that the required signalling traffic does not exceed the dimensioned capacity of the related signalling route or the SP's equipment. Therefore, capabilities may be needed by both the SP and PTNO to control the signalling traffic between the SP's equipment and the PTN.

7.6.2.4 Information flow chart

In the message sequence scenario a) in figure 45, traffic data is exchanged between the PTNorig and the related SPorig. In the second scenario b), traffic data is exchanged between the PTNterm and the related SPterm.

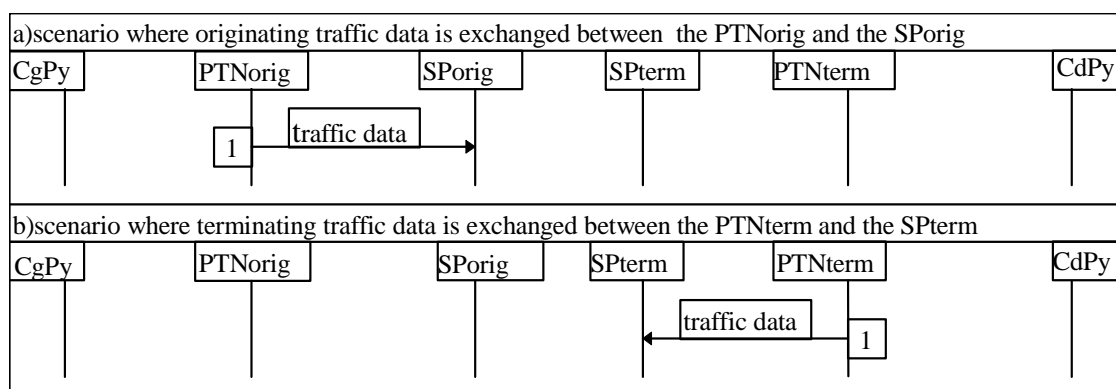

Figure 45: Traffic control capabilities

7.6.3 Avoidance of the cyclical routing of a call

Void.

8 Architectural view of the service provider access

8.1 Introduction

A variety of interfaces on different levels exist within public telecommunication networks, between them and for accessing them. The specification of intra and inter-working interfaces and a SPAI is important to both PTNOs and SPs, who desire a maximum flexibility in the deployment of new technology and introduction of new services. Intra-network interfaces are under the control and operation of public telecommunication network operators and are an integral part of their network architecture. Inter-network interfaces are used nationally and internationally between the networks of different PTNOs. Their implementation in the case of the SMP operators is subject to regulatory conditions. Regardless of the specification of the above mentioned interfaces, the network design strategy will be under the control of each PTNO, especially with respect to the relationship and interfaces with other PTNOs, SPs etc.

8.2 Network configuration scenarios

In this clause possible network configuration scenarios to connect the SP's equipment to the PTN are presented.

In figure 46 some possible network configuration are presented. These examples are based upon the IN technology. On the right, possible IN functions of the SP are shown. On the left, network functions that may be needed between the PTNO's SSF and the IN functions of the SP are shown.

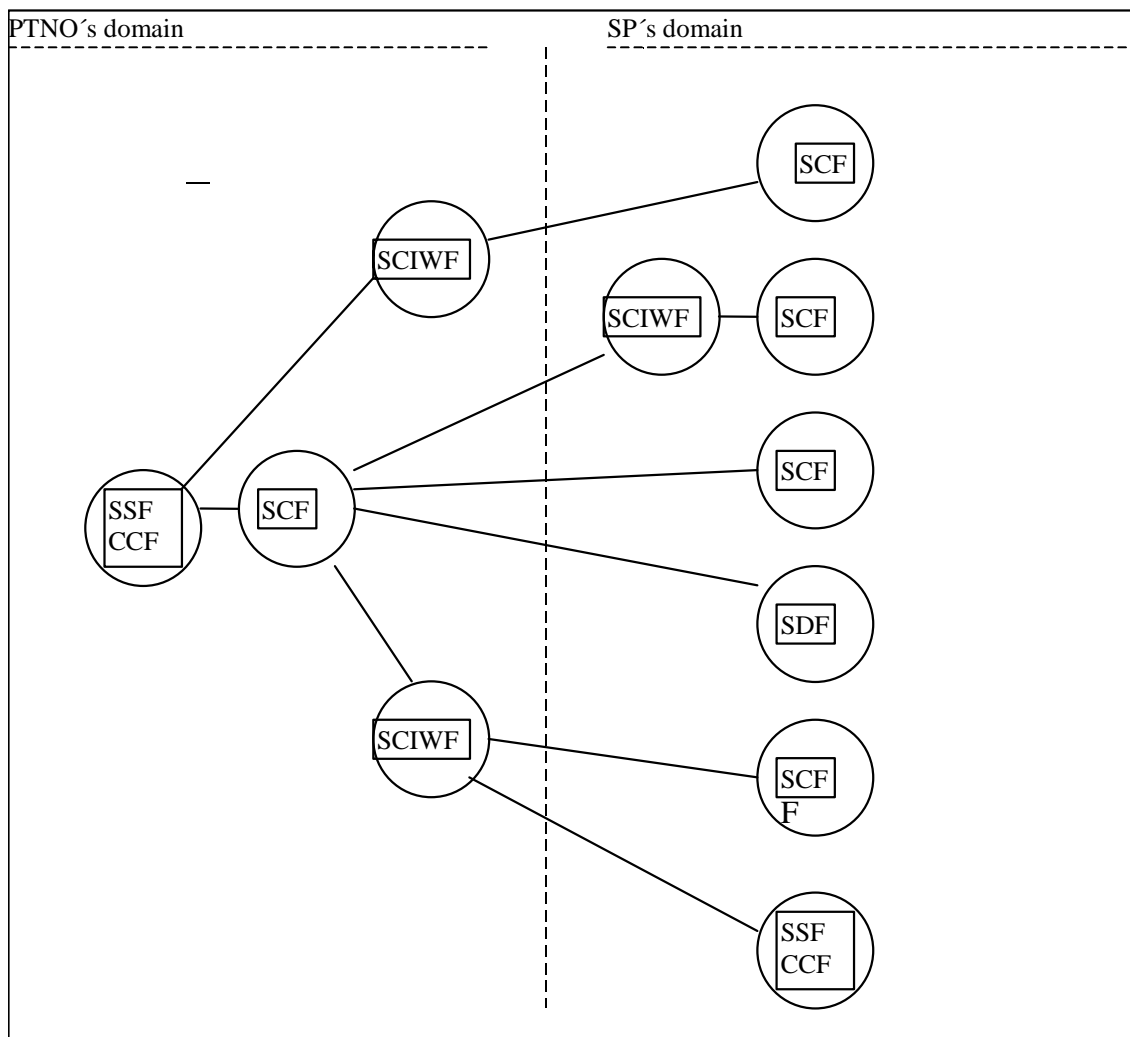

Figure 46: Possible network configurations based on the IN technology

CCF = Call Control Function
 SCF = Service Control Function
 SCIWF = Service Control Interworking Function
 SDF = Service Data Function
 SSF = Service Switching Function

The service control gateway function (SCIWF) performs e.g.:

- screening and filtering of messages and message parameters across the interface;
- mapping of messages and parameters;
- collection of usage information.

For a description of the IN functions CCF, SSF, SCF, SDF refer to the ITU-T series Q.1200 [16] Recommendations.

8.3 SPAI guidelines

The following principles are guidelines for the definition of the SPAI:

- A large part of the functionality of the SPAI can be achieved by making use of the capabilities provided over the other types of interfaces.
- PTNOs have requirements for the delivery of SPA (see EG 201 807 [4]).
- An SP may be connected to several PTNs simultaneously.
- Network interfaces need to be specified so that inter-network and access interfaces (including SPAI) have minimal dependency on the internal network architecture and intra-network interfaces.
- SPAI needs to be positioned as an interface between a PTN and other external entities, so that "firewall" functionality is either included within the interface itself or the PTNO automatically includes this "firewall" functionality behind the interface (see EG 201 807 [4]).
- The design of the SPAI needs to be based upon service capability requirements.

8.4 Service providers' interface scenarios

This clause provides examples of the different types of interface requirements that SPs have in delivering services over one or more PTNOs' networks. The solution types developed in these examples may be combined when required.

The purpose of these examples is to segment the SP's requirements so as to clarify that a suggested way forward is to design suitable interfaces for each segment. It is clear that a single interface will definitely not fit the requirements of all segments, because of differing requirements at the lower layers of the protocol.

- The first example is an SP that is usually connected to one network with ISDN primary rate access, and may typically be providing interactive voice response services. This SP will typically not have access to SS7, and the primary requirement is to drop calls back to the host network once their recording and playing of announcements has been completed. They also need to have access to CLI for authentication and billing. In this example, CR functions are the key requirement.
- The second example is an SP providing switch-based services and inter-connecting with a bearer-channel-SS7-based NNI, but in addition providing voice-processing-type services. This SP may also focus on the CR control requirements described in clause 6.
- The third example is an SP accessing the functions of a fixed PTN, using a combination of information technology systems and other PTNs in order to deliver services. The common factor is the requirement to integrate seamlessly other networks' functionality in order to construct their own service offering, without having to build their own access network. This type of SP will probably be IN-based [3], and will use a control interface to deliver services (i.e. no speech path connection except for the delivery of calls to the SP's own specialized resource point).

In the case of the examples above, the supporting protocol could respectively be an enhanced version of:

- DSS1;
- TUP or ISUP over SS7; and
- INAP, MAP, and CAMEL over SS7 or TCP/IP.

8.5 Functional framework of the SPA on the network level

SPs need access to the control plane (CP) functions and optionally also to the user plane (UP) functions of the PTNs. Moreover, management plane (MP) functions could be needed.

These planes are defined as follows:

- control plane is a layer-structured plane performing set-up, supervision, and release of calls and connections;
- user plane is a layer-structured plane providing for user information flow transfer, and associated control, e.g. flow control, and recovery from errors;
- management plane is a plane providing layer management and plane management functions in order to manage the functions of the control and user plane and their functional layers.

Management plane (MP) functions are visualized in figure 47, although the definition of management-related requirements is not included within the scope of the present document. The requirements that the SPs have to the PTNs can be split into two categories:

- CP functions of call control and service control in a PTN. The above mentioned CP functions can be provided by the control interface(s) located between the SP's equipment and PTN. The existing UNI may be insufficient to achieve the SP's commercial objectives. It should be noted that for many applications, the SP-controlled voice traffic may not exit the PTN.
- UP functions of transferring voice traffic between the SP's equipment and PTN. The above mentioned UP functions can be provided by the existing UNIs or NNIs.

This functional split allows the SP access requirements to be identified, without combining the two functions over one interface.

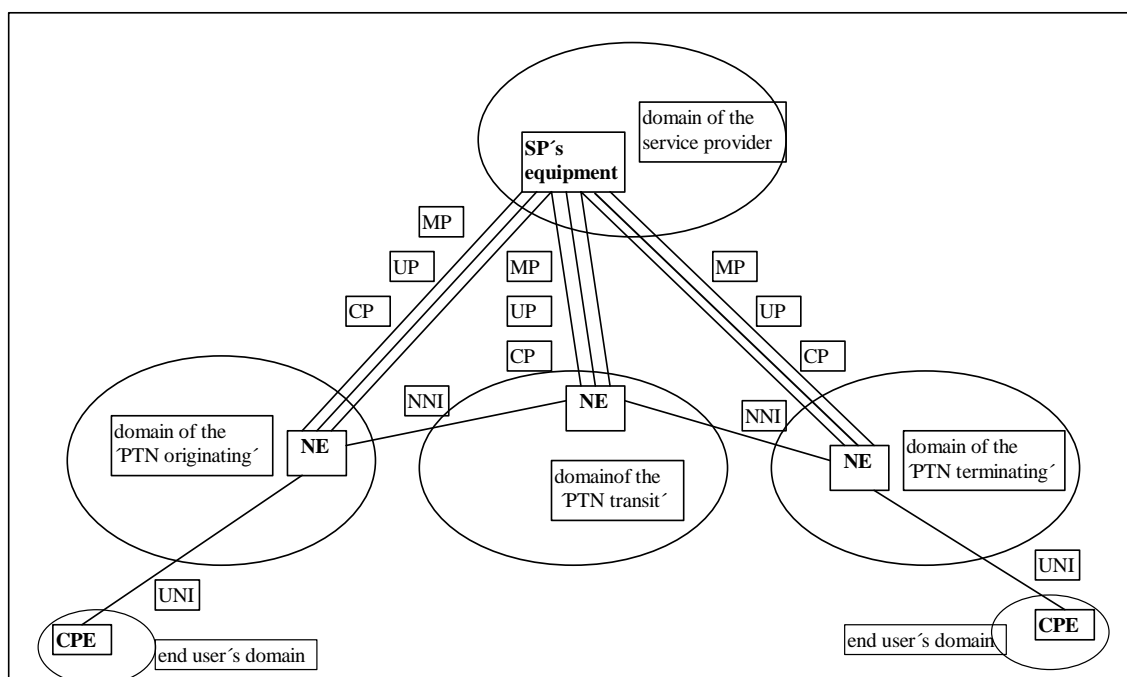

Figure 47: Location of the control-, user-, and management-related functions between the equipment of an SP and PTNs

Regarding figure 47 above, it should be noted that:

- The user plane interface between the SP and the originating, terminating, or transit network may be different from the existing UNIs.
- The originating and terminating network could be either fixed or mobile networks, although it is outside the scope of this work item to cover mobile networks and fixed-to-mobile convergence.
- A network element may refer to e.g. a local exchange, a transit exchange, a service switching point (SSP), or a service control point (SCP).

Annex A (informative): Bibliography

- ETSI EG 201 781: "Intelligent Networks (IN); Lawful interception".
- ETSI ES 201 158: "Telecommunications Security; Lawful Interception (LI); Requirements for network functions".
- ITU-T Recommendation Q.931 (1993): "Digital Subscriber Signalling System No.1; Network Layer; ISDN user-network interface layer 3 specification for basic call control".
- ITU-T Recommendation Q.761 (1997): "Signalling System No. 7; ISDN User Part functional description".
- ITU-T Recommendation Q.762 (1997): "Signalling System No. 7; ISDN User Part general functions of messages and signals".
- ITU-T Recommendation Q.763 (1997): "Signalling System No. 7; ISDN User Part formats and codes".
- ITU-T Recommendation Q.764: "Signalling System No. 7 – ISDN user part signalling procedures".
- ITU-T Recommendation Q.699 (1997): "Interworking between ISDN access and non-ISDN access over ISDN User Part of Signalling System No. 7".
- ETSI ETS 300 403-1 (1995) (including Corrigendum (1996)): "Integrated Services Digital Network (ISDN); Digital Subscriber Signalling System No. one (DSS1) protocol; Signalling network layer for circuit-mode basic call control; Part 1: Protocol specification".
- ETSI ETS 300 356-1 (1995): "Integrated Services Digital Network (ISDN); Signalling System No.7; ISDN User Part (ISUP) version 2 for the international interface; Part 1: Basic services [ITU-T Recommendations Q.761 to Q.764 (1993), modified]".
- ETSI EN 300 899-1: "Integrated Services Digital Network (ISDN); Signalling System No.7; Interworking between ISDN User Part (ISUP) version 2 and Digital Subscriber Signalling System No. one (DSS1); Part 1: Protocol specification [ITU-T Recommendation Q.699, modified]".
- ETSI ETS 300 374-1 (1994): "Intelligent Network (IN); Intelligent Network Capability Set 1 (CS1); Core Intelligent Network Application Protocol (INAP); Part 1: Protocol specification".
- ETSI ES 201 296: "Integrated Services Digital Network (ISDN); Signalling System No.7; ISDN User Part (ISUP); Signalling aspects of charging".
- ETSI EN 301 152-1: "Intelligent Network (IN); Intelligent Network Capability Set 1 (CS1) extension; Intelligent Network Application Protocol (INAP); Customised Applications for Mobile network Enhanced Logic (CAMEL); Part 1: Protocol specification".
- CCITT Recommendation I.112 (1988): "Vocabulary of terms for ISDNs".
- ETSI ETS 300 094 (1992): "Integrated Services Digital Network (ISDN); Connected Line Identification Presentation (COLP) supplementary service; Service description".
- ETSI ETS 300 095 (1992): "Integrated Services Digital Network (ISDN); Connected Line Identification Restriction (COLR) supplementary service; Service description".
- ETSI ETS 300 237 (1996): "Private Integrated Services Network (PISN); Specification, functional models and information flows; Name Identification supplementary services".
- ITU-T Recommendation Q.950 (1993): "Digital Subscriber Signalling System No.1 (DSS 1); Supplementary Services Protocols, Structure, and General Principles".
- ITU-T Recommendation Q.932 (1993): "Generic Procedures for the Control of ISDN Supplementary Services".
- EC (1997): "Green Paper on the Convergence of the Telecommunications, Media and Information Technology Sectors, and the Implications for Regulation Towards an Information Society Approach", COM(97)623, 3.12.97.

History

Document history		
V1.1.2	March 2000	Publication
V1.2.1	October 2000	Membership Approval Procedure MV 20001208: 2000-10-10 to 2000-12-08