

A guide to the application of TBR 21



European Telecommunications Standards Institute

Reference

DEG/ATA-005073 (ado00icq.PDF)

Keywords

PSTN, Terminal

ETSI Secretariat

Postal address

F-06921 Sophia Antipolis Cedex - FRANCE

Office address

650 Route des Lucioles - Sophia Antipolis
Valbonne - FRANCE
Tel.: +33 4 92 94 42 00 Fax: +33 4 93 65 47 16
Siret N° 348 623 562 00017 - NAF 742 C
Association à but non lucratif enregistrée à la
Sous-Préfecture de Grasse (06) N° 7803/88

X.400

c= fr; a=atlas; p=etsi; s=secretariat

Internet

secretariat@etsi.fr
<http://www.etsi.fr>

Copyright Notification

No part may be reproduced except as authorized by written permission.
The copyright and the foregoing restriction extend to reproduction in all media.

Contents

Intellectual Property Rights.....	4
Foreword	4
Introduction	4
1 Scope.....	5
2 References.....	5
3 Abbreviations.....	5
4 Advisory Notes that apply for all countries	5
5 Advisory Notes that apply for Germany	6
6 Advisory Notes that apply for Greece.....	6
7 Advisory Notes that apply for Portugal	6
8 Advisory Notes that apply for Spain.....	6
9 Advisory Notes that apply for Switzerland.....	7
Annex A: Advisory Notes	8
History	137

Intellectual Property Rights

IPRs essential or potentially essential to the present document may have been declared to ETSI. The information pertaining to these essential IPRs, if any, is publicly available for **ETSI members and non-members**, and can be found in ETR 314: "*Intellectual Property Rights (IPRs); Essential, or potentially Essential, IPRs notified to ETSI in respect of ETSI standards*", which is available **free of charge** from the ETSI Secretariat. Latest updates are available on the ETSI Web server (<http://www.etsi.fr/ipr>).

Pursuant to the ETSI Interim IPR Policy, no investigation, including IPR searches, has been carried out by ETSI. No guarantee can be given as to the existence of other IPRs not referenced in ETR 314 (or the updates on <http://www.etsi.fr/ipr>) which are, or may be, or may become, essential to the present document.

Foreword

This ETSI Guide (EG) has been produced by ETSI Project Analogue Terminals and Access (ATA).

Introduction

This ETSI Guide has been prepared in order that it may be referenced by the Commission Decision on the adoption of TBR 21 as a CTR. It should be applied in accordance with that Commission Decision.

NOTE: Prior to the adoption of the Commission Decision, the application of this ETSI Guide is outlined in the Foreword to TBR 21.

This ETSI Guide contains the Advisory Notes that are applicable to terminal equipment falling within the scope of TBR 21.

All of these Advisory Notes have resulted from comments made during national voting on TBR 21 in 1996.

The Advisory Notes are in two categories, as follows:

- a) those for which ATAAB has accepted collective responsibility. These are numbered in the series ATAAB AN -- They will be maintained and updated by ATAAB as necessary. They may apply in one or more countries as shown later in this document;
- b) those for which ATAAB has not accepted collective responsibility. These are numbered with a national prefix (CH, DE, ES, P etc.) and for convenience, historical sequence numbering has been retained. The content of these Advisory Notes is the responsibility of the national regulator in the country concerned. They will be maintained and updated as necessary by the national regulator. They are made publicly available by being introduced at ATAAB and by inclusion in this ETSI Guide.

Whilst every attempt will be made to keep this ETSI Guide up to date, readers are advised that the latest status of the Advisory Notes can be obtained from the ATAAB Chairman and on the Web Page <http://www.trac.org.uk>.

1 Scope

The present document gives guidance on the application of TBR 21 and is therefore applicable to Terminal Equipment falling within the scope of TBR 21.

2 References

References may be made to:

- a) specific versions of publications (identified by date of publication, edition number, version number, etc.), in which case, subsequent revisions to the referenced document do not apply; or
- b) all versions up to and including the identified version (identified by "up to and including" before the version identity); or
- c) all versions subsequent to and including the identified version (identified by "onwards" following the version identity); or
- d) publications without mention of a specific version, in which case the latest version applies.

A non-specific reference to an ETS shall also be taken to refer to later versions published as an EN with the same number.

- [1] TBR 21: "Terminal Equipment (TE); Attachment requirements for pan-European approval for connection to the analogue Public Switched Telephone Networks (PSTNs) of TE (excluding TE supporting the voice telephony service) in which network addressing, if provided, is by means of Dual Tone Multi-Frequency (DTMF) signalling".

3 Abbreviations

For the purposes of this EG, the abbreviations of TBR 21 apply, in addition to the following:

ACTE	Advisory Committee for Terminal Equipment
AN	Advisory Note
ATAAB	TRAC Analogue Type Approval Advisory Board
CEPT	Conférence des Administrations Européennes des Postes et Télécommunications
PSTN	Public Switched Telephone Network
TE	Terminal Equipment
TRAC	Technical Regulations Applications Committee

4 Advisory Notes that apply for all countries

The following Advisory Notes which appear in annex A are applicable for all countries:

- ATAAB AN 003
- ATAAB AN 004

5 Advisory Notes that apply for Germany

The following Advisory Notes which appear in annex A are applicable for Terminal Equipment intended for connection to the German PSTN in addition to those given in clause 4:

- ATAAB AN 005
- ATAAB AN 006
- ATAAB AN 007
- ATAAB AN 009
- ATAAB AN 010
- DE 03
- DE 04
- DE 05
- DE 08
- DE 09
- DE 12
- DE 14
- DE 17

6 Advisory Notes that apply for Greece

The following Advisory Notes which appear in annex A are applicable for Terminal Equipment intended for connection to the Greek PSTN in addition to those given in clause 4:

- ATAAB AN 005
- ATAAB AN 006
- GR 01
- GR 02
- GR 03
- GR 04

7 Advisory Notes that apply for Portugal

The following Advisory Notes which appear in annex A are applicable for Terminal Equipment intended for connection to the Portuguese PSTN in addition to those given in clause 4:

- ATAAB AN 001
- ATAAB AN 005
- ATAAB AN 006
- ATAAB AN 007
- ATAAB AN 011
- P03
- P04
- P08
- P10

8 Advisory Notes that apply for Spain

The following Advisory Notes which appear in annex A are applicable for Terminal Equipment intended for connection to the Spanish PSTN in addition to those given in clause 4:

- ATAAB AN 005
- ATAAB AN 007
- ATAAB AN 012
- ES 01

9 Advisory Notes that apply for Switzerland

The following Advisory Note which appears in annex A is applicable for Terminal Equipment intended for connection to the Swiss PSTN in addition to those given in clause 4:

- ATAAB AN 002

Annex A: Advisory Notes

This Annex contains the set of notes described in the main body of this document.

For convenience they are organized as follows:

- ATAAB Advisory Notes in number sequence.
- National Notes in the following order Germany, Greece, Portugal, Spain.

Table A.1: Advisory Notes

AN (applicability)	Subject, contents
AN 001 (P)	5 s waiting before automatic dialling (limit reduction from 8 s to 5 s).
AN 002 (CH)	24 Vrms ringing detection (limit reduction from 30 V to 24 V).
AN 003 (General)	Variation of signals supplied by the PSTN.
AN 004 (General)	DTMF dialling and CEPT recommendations.
AN 005 (DE / GR / P / ES)	Automatic line clearing conditions.
AN 006 (DE / GR / P)	Additional test voltage (150 V) for resistance to Earth.
AN 007 (DE / P / ES)	Control requirements (release line if no correct operation) in the case of external power failure.
AN 009 (DE)	Instantaneous voltage tested over a wider frequency range.
AN 010 (DE)	Sending levels according TBR15.
AN 011 (P)	2 min answering for automatic devices.
AN 012 (ES)	Immunity to polarity reversals.
DE 03 / GR 03	Sending level in quiescent state should be the same as in loop state.
DE 04 / GR 04	Overloading test (6.5 s) with extreme conditions ringing signalling.
DE 05 / GR 01 / P 08	Seizing the line without making a call.
DE 08	Lower limit voltage in DC characteristics.
DE 09	Return loss (reference Zr) during DTMF dialling > 14 dB (limit increase of 6 dB).
DE 12	Output signal balance during DTMF (increase of approximately 6dB).
DE14	Transition from loop to quiescent (increase of the threshold).
DE 17	Definition of a feeding bridge.
GR 02 / P 10	Additional requirements for Loop/disconnect (Decadic) dialling lines.
P 03	Impedance in quiescent state for voice and AoC 12 kHz signals.
P 04	Series installed TE (DC resistance, delay in releasing the line, insertion loss).
ES 01	DC characteristics mask is different.

List of Advisory notes

ATAAB Advisory Note Number: AN 01.....	10
ATAAB Advisory Note Number: AN 02.....	16
ATAAB Advisory Note Number: AN 03.....	21
ATAAB Advisory Note Number: AN 04.....	23
ATAAB Advisory Note Number: AN 05.....	25
ATAAB Advisory Note Number: AN 06.....	33
ATAAB Advisory Note Number: AN 07.....	38
ATAAB Advisory Note Number: AN 09.....	43
ATAAB Advisory Note Number: AN 10.....	48
ATAAB Advisory Note Number: AN 11.....	54
ATAAB Advisory Note Number: AN 12.....	58
German Advisory Note Number: DE 03	64
German Advisory Note Number: DE 04	68
German Advisory Note Number: DE 05	73
German Advisory Note Number: DE 08	75
German Advisory Note Number: DE 09	81
German Advisory Note Number: DE 12	86
German Advisory Note Number: DE 14	92
German Advisory Note Number: DE 17	97
Greek Advisory Note Number: GR 01	102
Greek Advisory Note Number: GR 02	104
Greek Advisory Note Number: GR 03	106
Greek Advisory Note Number: GR 04	110
Portuguese Advisory Note Number: P 03.....	115
Portuguese Advisory Note Number: P 04.....	120
Portuguese Advisory Note Number: P 08.....	127
Portuguese Advisory Note Number: P 10.....	129
Spanish Advisory Note Number: ES 01.....	131

ATAAB ADVISORY NOTE

TRAC Analogue Type Approval Advisory Board

ATAAB Advisory Note Number: AN 01

Subject: Additional requirements for attachment to the Portuguese PSTN

APPLICABILITY

This note is applicable for Terminal Equipment intended for connection to the Portuguese Public Switched Telephone Network, in addition to:

CTR 21 (When published)

NOTE: Until CTR 21 is available, reference should be made to ETSI document TBR 21 (Sept 1997) or, when it is available, to TBR 21.

Appendix to this Advisory Note:

A: Additional requirements and tests for attachment to the Portuguese PSTN

In consideration of the following:

- Terminals connected to the Portuguese PSTN can only be assured of the presence of dial tone for 5 seconds following seizure;
- TE approved to CTR 21 will need to note these additional requirements when a TE is intended for connection to the Portuguese Public Switched Telephone Network.

ATAAB advises the following:

To be able to inter-work properly with the Portuguese Public Switched Telephone Network, the TE shall, in addition to the requirements of CTR 21, comply with the requirements found in Appendix A of this Advisory Note.

It is the responsibility of the supplier to provide information for users as to whether the Terminal Equipment complies with the additional requirements for the Portuguese Public Switched Telephone Network specified in this Advisory Note.

Appendix A also specifies the method to assess compliance with the additional requirement, including reference to the additional tests to be performed to dynamically assess compliance with the additional requirements.

ATAAB

TRAC Analogue Type Approval Advisory Board

Appendix A

to

ATAAB Advisory Note Number: AN 01

Subject: Additional requirements and tests for attachment to the Portuguese Public Switched Telephone Network

A.1 INTRODUCTION

Terminal equipment approved to CTR 21 may not inter-work properly with the Portuguese Public Switched Telephone Network.

This Appendix specifies requirements to which a TE shall comply, in addition to the requirements of CTR 21 in order to inter-work properly with the Portuguese Public Switched Telephone Network. It also specifies the method to assess compliance with these additional requirements, including reference to additional tests to be performed to dynamically assess compliance with the additional requirements.

A.2 NORMATIVE REFERENCES

- [1] CTR21; Terminal Equipment (TE). Attachment requirements for pan-European approval for connection to the analogue Public Switched Telephone Networks (PSTNs) of TE (excluding TE supporting the voice Telephony Service) in which network addressing, if provided, is by means of Dual Tone Multi-Frequency (DTMF) signalling.

NOTE: This document makes reference to CTR 21. Until CTR 21 is available, reference should be made to the base ETSI documents prTBR 21 (Sept 1997) or, when it is available, to TBR 21.

A.3 REQUIREMENTS and ASSOCIATED TESTS

A.3.1 Automatic dialling

NOTE: The following requirements are in addition to the requirements of CTR 21 Clause 4.8.1 and the associated tests in Clause A.4.8.1. The changes introduced by this Advisory Note reduce the maximum time before which the TE must send the first digit from 8s to 5s.

A.3.1.1 Dialling without dial tone detection (Requirement - Based on CTR 21: Clause 4.8.1.1)

Justification: 91/263/EEC, Article 4(f); Inter-working with the PSTN is assured by requiring a TE with automatic dialling to start sending its digits during the time period when the network is ready to receive digits under normal conditions. The Portuguese PSTN may not be capable of accepting addressing information later than 5 seconds after line seizure.

Requirement: The TE shall start dialling not earlier than 2,7 s and before 5 s has elapsed after the loop state is established. Where adjustments are available to the user, resulting in a lower value, this is acceptable as long as the 2,7 s limit remains within the available range.

NOTE: It is recognized that, in some rare cases, the network may not be able to receive dialling signals within 3 s.

Test: The test shall be conducted according to A.3.1.2

A.3.1.2 Dialling without dial tone detection (Test - based on CTR 21: Clause A.4.8.1.1)

Requirement: Subclause A.3.1.1.

Purpose: To check that the TE starts dialling within the allowed period after seizure.

Measurement principle:

Preamble: Set the TE in quiescent state, tone-detector if any, disabled. If the pause before dialling is adjustable by the user, set it in accordance with the supplier's instructions to the closest available value to the midpoint between 3 and 5 s. If two values are equally close to the mid point, then use the lower value.

Test state: Automatic DTMF dialling.

Test configuration:

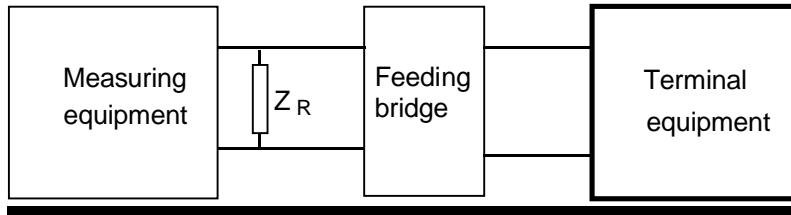

Figure A.1

DC feeding arrangement: Feed voltage: 50 V. Feed resistance: 850 Ω .

AC termination of TE: Z_R .

Measurement execution:

The TE is set in the loop state, transmitting signalling characters to line. The time shall be measured from seizure up to the start of the first digit.

Formal processing: None.

Verdict: If the time delay is equal to or greater than 2,7 s and dialling has started within 5 s then Pass; else Fail.

Guidance: None.

A.3.1.3 Dialling with dial tone detection (Requirement - Based on CTR 21: Clause 4.8.1.2)

Justification: 91/263/EEC, Article 4(f); Inter-working with the PSTN is assured by requiring a TE with automatic dialling to start sending its digits during the time period when the network is ready to receive digits. The Portuguese PSTN may not be capable of accepting addressing information later than 5 seconds after dial tone has been presented.

Requirement: If the TE is intended for automatic dialling with an automatic dial tone detection, and this facility is enabled in accordance with the supplier's instruction, it shall start dialling within 5 s of the start of the application of continuous dial tone;

For the purposes of this requirement, the dial tone is defined as a single tone signal, delivered from a generator with a source impedance equal to Z_R , in the frequency range 300 Hz to 500 Hz, whose level is between -35,7 dBV and -0,7 dBV when measured across the reference impedance Z_R which substitutes the TE.

Test: The test shall be conducted according to A.3.1.4

A.3.1.4 Dialling with dial tone detection (Test - Based on CTR 21: Clause A.4.8.1.2)

Requirement: Subclause A.3.1.3.

Purposes: To check whether, after seizure, the TE starts dialling within the allowed period after the start of the dial tone.

Measurement principle:

Preamble: Set the TE in quiescent state with dial tone detector enabled.

Test state: Automatic DTMF dialling.

Test configuration:

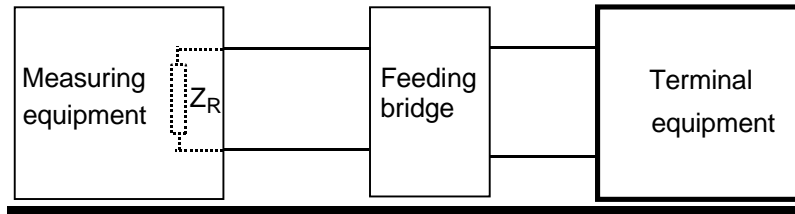

Figure A.2

DC feeding arrangement: Feed voltage: 50 V. Feed resistance: 850 Ω .

AC termination of TE: Z_R .

Measurement points: The detection range that shall be tested is limited by the frequencies and voltage levels given in the table below. The levels are defined across the reference impedance Z_R .

Detection range, frequencies:

Frequency (Hz)	Level (dBV)
300	- 0,7
300	- 35,7
500	- 35,7
500	- 0,7

Measurement execution:

The TE is set in the loop state, ready for transmitting signalling tones to the line.
In the test dial tone is activated 3 s after having established the loop state.
Send continuous dial tone. Time is measured from the start of the dial tone;

Formal processing: None.

Verdict: If the TE has started dialling before 5 s in the test, measured from the start of the dial tone, then Pass; else Fail.

Guidance: The level is supplied from a generator such that the total impedance of the generating and feeding circuitry is Z_R . The TE is replaced by a matching impedance Z_R for the purpose of level measurement. The TE is in-circuit for the purpose of timing measurement.

A.3.1.5 Requirements Table (CTR-RT)

The requirements table of CTR 21, Annex B is still applicable.

ATAAB ADVISORY NOTE

TRAC Analogue Type Approval Advisory Board

ATAAB Advisory Note Number: AN 02

Subject: Additional requirements for attachment to the Swiss PSTN

APPLICABILITY

This note is specifically applicable for Terminal Equipment intended for connection to the Swiss Public Switched Telephone Network, in addition to:

CTR 21 (When published)

NOTE: Until **CTR 21** is available, reference should be made to ETSI document prTBR 21 (Sept 1997) or, when it is available, to TBR 21.

Appendix to this Advisory Note:

A: Additional requirements and tests for attachment to the Swiss PSTN.

In consideration of the following:

- The ringing voltage delivered by the Swiss PSTN may be as low as 24 Vrms;
- TE approved to CTR 21 will need to note these additional requirements when a TE is intended for connection to the Swiss Public Switched Telephone Network.

ATAAB advises the following:

To be able to inter-work properly with the Swiss Public Switched Telephone Network, the TE shall, in addition to the requirements of CTR 21, comply with the requirements found in Appendix A of this Advisory Note.

It is the responsibility of the supplier to provide information for users as to whether the Terminal Equipment complies with the additional requirements for the Swiss Public Switched Telephone Network specified in this Advisory Note.

Appendix A also specifies the method to assess compliance with the additional requirement, including reference to the additional test to be performed to dynamically assess compliance with the additional requirement.

ATAAB

TRAC Analogue Type Approval Advisory Board

Appendix A

to

ATAAB Advisory Note Number: AN 02

Subject: Additional requirements and tests for attachment to the Swiss Public Switched Telephone Network.

A.1 INTRODUCTION

Terminal Equipment approved to CTR 21 may not inter-work properly with the Swiss Public Switched Telephone Network.

This Appendix specifies requirements to which a TE shall comply, in addition to the requirements of CTR 21 in order to inter-work properly with the Swiss Public Switched Telephone Network. It also specifies the method to assess compliance with these requirements, including reference to additional tests to be performed to dynamically assess compliance with the additional requirements.

A.2 NORMATIVE REFERENCES

- [1] CTR21; Terminal Equipment (TE). Attachment requirements for pan-European approval for connection to the analogue Public Switched Telephone Networks (PSTNs) of TE (excluding TE supporting the voice Telephony Service) in which network addressing, if provided, is by means of Dual Tone Multi-Frequency (DTMF) signalling.

NOTE: This document makes reference to CTR 21. Until CTR 21 is available, reference should be made to the base ETSI documents prTBR 21 (June 1996) or, when it is available, to TBR 21.

A.3 REQUIREMENTS and ASSOCIATED TESTS

NOTE: The following requirement is similar to and in addition to those in CTR 21 Clause 4.5 and the associated tests in Clause A.4.5. The difference between the requirements in this Advisory Note and the original requirement in CTR 21 relates to the ringing voltage available to the TE at 25 Hz which is 24V in this document and 30V in CTR 21.

A.3.1 Ringing signal detector sensitivity(Requirement - Based on CTR 21: Clause 4.5)

Justification: 91/263/EEC, Article 4(f); Inter-working with the PSTN is assured by requiring the TE to detect valid ringing signals. The Swiss PSTN may not be capable of providing a TE with a ringing voltage that exceed 24 Vrms.

Requirement: If a ring detect function is provided and enabled, the TE shall be able to respond to ringing signals of 24 Vrms at 25 Hz with a cadence of 1 s ON and 5 s OFF, superimposed on a 50 VDC feeding voltage.

The response shall be as stated by the supplier.

Test: The test shall be conducted according to Clause A.3.2

A.3.2 Ringing signal detector sensitivity (Test- Based on CTR 21: Clause A.4.5)

Requirement: Subclause A.3.1.

Purpose: To determine the ability of the TE to respond as stated to ringing signals as specified by the supplier.

Measurement principle:

Preamble: Set the TE in quiescent state with answering facility enabled.

Test state: Quiescent state.

Test configuration:

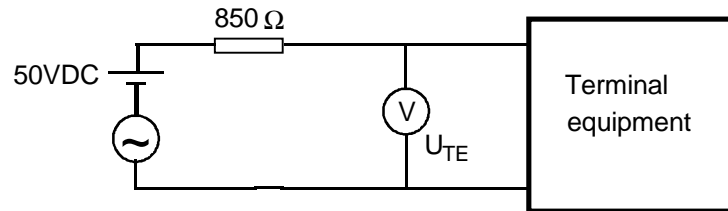

Figure A.1

DC feeding arrangement: Feed Voltage = 50 V DC.

Measurement points: The ringing signal shall have a sinusoidal source of 25 Hz and a cadence of 1 s ON and 5 s OFF.

$$U_{TE} = 24 \text{ Vrms}$$

Safety Warning: This test presents the potential for a shock hazard. Ensure satisfactory safety precautions are implemented to reduce the risk of electric shock.

Measurement execution:

Using the test configuration shown in figure A.1, apply, the ringing signal described in "Measurement points" to the circuit to determine whether it is detected by the TE as stated by the supplier.

Formal processing: None.

Verdict: If the TE detects the ringing signal described above in "Measurement points" then Pass; else Fail.

Guidance: For automatic answering TE, after the stimulation to cause the seizure, the requirement stated in CTR 21, subclause 4.6.2 and its associated test case apply.

A.3.3 Requirements Table (CTR-RT)

The requirements table of CTR 21, Annex B is still applicable.

ATAAB ADVISORY NOTE

TRAC Analogue Type Approval Advisory Board

ATAAB Advisory Note Number: AN 03

Subject: Variation of signals supplied by the PSTN

APPLICABILITY

This note is applicable for Terminal Equipment intended for connection to Public Switched Telephone Networks, in addition to:

" CTR 21" (When published)

NOTE: Until CTR 21 is available, reference should be made to ETSI document prTBR 21 (Sept 1997) or, when it is available, to TBR 21.

This note contains specific advice concerning the relationship between the requirements and tests of CTR 21 and the range of network generated signals that will be encountered in practice.

In consideration of the following:

- The needs of Terminal Equipment Suppliers/Manufacturers and Network Operators are best addressed by a simple and unambiguous approvals regime;
- Extensive testing of Terminal Equipment cannot provide an assurance that a terminal and the network will inter-work in all circumstances;
- That the nominal values for any particular network signal is not the same for all networks and the deviation from the nominal for any particular network signal may also vary.

ATAAB advises the following:

Manufacturers and Suppliers of Terminal Equipment intended to connect to the PSTN are urged: -

- to consult documents such as ETS 300 001 and the declarations provided by network operators under the amended ONP voice telephony directive, and
- to use this information to ensure that their terminals are still capable of inter-working with the network when faced with signals that are towards the extremes of the network tolerances.

As an example attention is drawn to Clause 4.5, which requires "If a ring detect function is provided and enabled, the TE shall be able to respond to ringing signals of 30 V r.m.s. at 25 Hz and 50 Hz with a cadence of 1 s ON and 5 s OFF, superimposed on a 50 VDC feeding voltage."

- 1) The ringing voltage stated is the minimum likely to be encountered for most networks. Voltages that are greater than 30V will be found on the vast majority of connections.
- 2) The ringing frequency can be either 25 Hz or 50 Hz depending on the network to which the terminal is connected and the frequency will also have a tolerance that could be as high as 20 %.
- 3) The D.C. voltage on which the ringing voltage is superimposed may be greater or less than 50VDC..
- 4) The cadence stated was chosen to give the lowest available voltage when aggregated over the duration of cadence. The cadence of ringing signals also has a tolerance, varies from network to network and a different cadence may be used by the network operator to indicate that certain supplementary services have been invoked. In the latter case it may be appropriate for a terminal that would normally be capable of automatically answering the call not to do so (or vice versa).

ATAAB ADVISORY NOTE

TRAC Analogue Type Approval Advisory Board

ATAAB Advisory Note Number: AN 04

Subject: DTMF signalling

APPLICABILITY

This note is applicable for Terminal Equipment intended for connection to Public Switched Telephone Networks, in addition to:

" CTR 21" (When published)

NOTE: Until CTR 21 is available, reference should be made to ETSI document prTBR 21 (Sept 1997) or, when it is available, to TBR 21.

This note contains specific advice concerning the generation of DTMF digits when used to address the PSTN.

In consideration of the following:

- That most European Networks incorporate receivers for DTMF signals that meet CEPT Recommendation T/CS 46-02 as reproduced in ETSI Technical Report ETR 206;
- That DTMF senders should meet the requirements as laid down in CEPT Recommendation T/CS 46-02 (ETSI ETR 206) when an unregulated generator is used or CEPT Recommendation T/STI 46-04 (ETSI ETR 207) when a regulated generator is used, and both standards require that a DTMF sender shall operate correctly in the presence of dial tone;
- That the first digit will normally be transmitted while receiving dial tone and, if the terminal sends unwanted frequencies caused by interference between transmitted digit and dial tone or allows the frequencies of the transmitted digit to be affected by dial tone, then the first digit may not be recognized;
- That networks need to be able to determine the start of each DTMF digit in order to interpret the information correctly;
- Some networks incorporate receivers for DTMF-signals that do not meet CEPT Recommendation T/CS 46-02 and which are likely to reject the last digit if the final digit of the number is not followed by a period where the level of any signal is at least 20 dB below the level of the low frequency group component.

ATAAB advises the following:

That an additional general note be added to Clause 4.8.2 of CTR 21, as follows:

NOTE: The initial digit of the network address will normally be sent with dial tone present. In order for the network to recognize this digit, the signals returned to the network must be sufficiently free of unwanted frequency components. In particular when sending DTMF digits in the presence of dial tone, the frequencies produced should remain within the frequency tolerance (see Clause 4.8.2.1) and the total level of unwanted frequencies in the range 250 Hz to 4300 Hz, excluding the frequency of the dial tone itself, should be at least 20 dB below the level of the low frequency group component (see Clause 4.8.2.3). It should also be noted:

- that the frequency or frequencies provided for dial tone varies from network to network,
- that the dial tone may be a continuous tone or may be cadenced with a network dependent on to off ratio,
- that network dependent special dial tones may be provided in case of invoked supplementary services and
- that dial tone could be present at a level as high as -0,7 dBV (see Clause 4.8.1.2).

According to CEPT Recommendation T/CS 46-02 and for the purposes of Clauses 4.8.2.4 and 4.8.2.5 of CTR 21, a DTMF digit sequence should be comprised of periods of tone-on separated by pauses. For the specification of a pause condition reference should be made to CEPT Recommendation T/CS 46-02 Section 3.3.3.2.

However, to cater for certain networks incorporating DTMF receivers which do not meet CEPT Recommendation T/CS 46-02, it is recommended exceptionally to provide a pause condition following sending of the last DTMF tone-on period.

ATAAB ADVISORY NOTE

TRAC Analogue Type Approval Advisory Board

ATAAB Advisory Note Number: AN 05

Subject: Automatic clearing of automatically originated or answered PSTN calls.

APPLICABILITY

This note is applicable for Terminal Equipment intended for connection to the German, Greek, Portuguese and Spanish Public Switched Telephone Networks, in addition to:

" CTR 21" (When published)

NOTE: Until CTR 21 is available, reference should be made to ETSI document prTBR 21 (Sept 1997) or, when it is available, to TBR 21.

Appendices to this Advisory Note:

- A. Additional requirement and tests for the clearing of automatic calls on the PSTNs of Greece, Portugal and Spain.
- B. Additional requirement and tests for the clearing of automatic calls on the PSTN of Germany.

In consideration of the following:

- That terminal equipment that is capable of Automatically Calling and/or Automatically Answering calls should also be capable of automatically releasing an established call;
- That continued holding the line when no useful information is being sent results in continued billing and can prevent incoming calls being presented.
- That it should be possible for Terminal Equipment to detect that a connection has failed and release the line by automatically changing from the loop condition to the quiescent condition.

ATAAB advises the following:

To be able to inter-work properly with the German, Greek, Portuguese and Spanish Public Switched Telephone Networks, the TE shall, in addition to the requirements of CTR 21, comply with the requirements found in the relevant appendix to this Advisory Note.

It is the responsibility of the supplier to provide information for users as to whether the Terminal Equipment complies with the additional requirements for the German, Greek, Portuguese and Spanish Public Switched Telephone Networks specified in this Advisory Note.

The relevant appendix specifies the method to assess compliance with the additional requirement, including reference to the additional test to be performed to dynamically assess compliance with the additional requirement.

ATAAB

TRAC Analogue Type Approval Advisory Board

Appendix A

to

ATAAB Advisory Note Number: AN 05

Subject: Additional requirement and tests for the clearing of automatic calls on the PSTNs of Greece, Portugal and Spain.

A.1 INTRODUCTION

Terminal equipment approved to CTR 21 may not inter-work properly with the Public Switched Telephone Networks in Greece, Portugal and Spain.

This Appendix specifies requirements to which a TE shall comply, in addition to the requirements of CTR 21 in order to inter-work properly with the Greek, Portuguese and Spanish Public Switched Telephone Networks. It also specifies the method to assess compliance with these requirements, including reference to additional tests to be performed to dynamically assess compliance with the additional requirements.

A.2 NORMATIVE REFERENCES

- [1] CTR21: Terminal Equipment (TE). Attachment requirements for pan-European approval for connection to the analogue Public Switched Telephone Networks (PSTNs) of TE (excluding TE supporting the voice Telephony Service) in which network addressing, if provided, is by means of Dual Tone Multi-Frequency (DTMF) signalling.

NOTE: This document makes reference to CTR21. Until CTR 21 is available, reference should be made to the base draft ETSI document prTBR 21 (Sept 1997), or when it is available, to TBR21.

A.3 REQUIREMENTS AND ASSOCIATED TESTS

NOTE: The following requirement applies only to TE with the facility of automatic calling or automatic answering and are in addition to the requirements of CTR 21 Clause 4.9 and its associated tests in A.4.9.

A.3.1 Liberation of Loop condition by the TE (Requirement)

Justification: 91/263/EEC, Article 4(f); Interworking with the PSTN is assured by requiring a TE that is intended to automatically release the line to assume the off-line state when a call is no longer established.

Requirement: For TE that is intended to automatically releasing the line shall, when the normal signals that are exchanged between terminals are interrupted or replaced by appropriate network supervisory tones/condition, the TE shall assume the quiescent state within 360 s of the interruption.

Test: The test shall be conducted according to Clause A.3.2

A.3.2 Liberation of Loop condition by the TE (Test)

Requirement: Subclause A.3.1

Purpose: To determine the ability of the TE to detect 1) the loss of signals from the distant terminal or 2) the existence of appropriate network supervisory tones, and that the TE subsequently releases the line.

Measurement principle:

Preamble: Set the TE in on-line state exchanging signals with a compatible terminal. The automatic clearing function should be enabled.

Test state: On-line state

Test configuration:

Figure A.3.1: Liberation of loop condition

DC feeding arrangements: Feed voltage = 50 V.

Measurement points: The network tones shall be as detailed in Table A.1.

Table A.1 Network Supervisory Tones and Conditions for the purpose of testing automatic clearing.

Clearing Conditions	Frequency / Level	Cadence (Signal/silence)
Busy tone	425Hz / = -30 dBm	200 / 200 ms
Number Unobtainable Tone	425Hz / = -30 dBm	2x200 / 200 + 600 ms
Congestion Tone	425Hz / \geq -30 dBm	3x200 / 2x200+600 ms
Absence of signal	Interruption of the reception path of the TEUT	> 360s

NOTE: In some old exchanges, the "Congestion tone" has the same characteristics of the "Busy tone". The values given in table A.1 have tolerances of 15 % for the frequencies, and of 10 % for the times in the congestion tone and of 20 % for the times in the rest of the signals.

Formal processing: The normal transmission in the reception path of the TEUT is interrupted, and the first signal of the table A.1 is applied so as to appear at the line terminals of the TEUT, until 360s) has elapsed. This process is repeated for the rest of the signals.

Verdict: If the TE goes to quiescent state in each of the tests in less than 360s then Pass; else Fail.

Guidance: None

ATAAB

TRAC Analogue Type Approval Advisory Board

Appendix B

to

ATAAB Advisory Note Number: AN 05

Subject: Additional requirement and tests for the clearing of automatic calls on the German PSTN

B.1. INTRODUCTION

Terminal equipment approved to CTR 21 may not inter-work properly with the German Public Switched Telephone Network.

This Appendix specifies requirements to which a TE shall comply, in addition to the requirements of CTR 21 in order to inter-work properly with the German Public Switched Telephone Network. It also specifies the method to assess compliance with these requirements, including reference to additional tests to be performed to dynamically assess compliance with the additional requirements.

B.2 NORMATIVE REFERENCES

- [1] CTR21: Terminal Equipment (TE). Attachment requirements for pan-European approval for connection to the analogue Public Switched Telephone Networks (PSTNs) of TE (excluding TE supporting the voice Telephony Service) in which network addressing, if provided, is by means of Dual Tone Multi-Frequency (DTMF) signalling.

NOTE: This document makes reference to CTR21. Until CTR 21 is available, reference should be made to the base draft ETSI document prTBR 21 (Sept 1997), or when it is available, to TBR21.

B.3 REQUIREMENTS AND ASSOCIATED TESTS

NOTE: The following requirement applies only to TE with the facility of automatic calling or automatic answering and are in addition to the requirements of CTR 21 Clause 4.9 and its associated tests in A.4.9.

B.3.1 Liberation of Loop condition by the TE (Requirement)

Justification: 91/263/EEC, Article 4(f); Interworking with the PSTN is assured by requiring a TE that is intended to automatically release the line to assume the off-line state when a call is no longer established.

Requirement: For TE that is intended to automatically releasing the line shall, when the normal signals that are exchanged between terminals are interrupted, the TE shall assume the quiescent state within 180 s of the interruption.

Test: The test shall be conducted according to Clause B.3.2

B.3.2 Liberation of Loop condition by the TE (Test)

Requirement: Subclause B.3.1

Purpose: To determine the ability of the TE to detect the loss of signals from the distant terminal and that the TE subsequently releases the line.

Measurement principle:

Preamble: Set the TE in on-line state exchanging signals with a compatible terminal. The automatic clearing function should be enabled.

Test state: On-line state

Test configuration:

Figure B.3.1: Liberation of loop condition

DC feeding arrangements: Feed voltage = 50 V.

Measurement points: The network tones shall be as detailed in Table 1.

Table B.1 Network Supervisory Tones and Conditions for the purpose of testing automatic clearing

Clearing Conditions	Frequency / Level	Cadence (Signal/silence)
Absence of signal	Interruption of the reception path of the TEUT	> 180s

Formal processing:

The normal transmission in the reception path of the TEUT is interrupted, and the first signal of the table A.1 is applied so as to appear at the line terminals of the TEUT, until 180s has elapsed.

Verdict:

If the TE goes to quiescent state in each of the tests in less than 180 s then Pass; else Fail.

Guidance:

None

ATAAB ADVISORY NOTE

TRAC Analogue Type Approval Advisory Board

ATAAB Advisory Note Number: AN 06

Subject: Adding a second test-point to the test of the resistance to earth.

APPLICABILITY

This note is applicable for Terminal Equipment intended for connection to the German, Greek, Portuguese and Spanish Public Switched Telephone Networks, in addition to:

" CTR 21" (When published)

NOTE: Until CTR 21 is available, reference should be made to ETSI document prTBR 21 (Sept 1997) or, when it is available, to TBR 21.

Appendix to this Advisory Note:

A: Additional requirements and tests for attachment to the PSTN in Germany, Greece and Portugal.

In consideration of the following:

- One wire of the line in the network is connected to earth at the switch. The resistance to earth of the other wire is therefore the resistance between the two wires.
- The ringing signal is up to 63 VDC plus up to 75 VAC.
- A resistance of less than 100 k Ω can cause ring tripping.
- Ring tripping can occur, when the resistance to earth is less than 100 k Ω .
- For correct inter-working between the TE and the PSTN in the Germany, Greece and Portugal, the resistance to Earth at 150 V has to be more than 100 k Ω

ATAAB advises the following:

To the test of the resistance to earth, there shall be added a new test-point.

To ensure inter-working with the Public Switched Telephone Network in Germany, Greece and Portugal, the TE shall, in addition to the requirements of CTR 21, comply with the requirements found in Appendix A of this Advisory Note.

It is the responsibility of the supplier to provide information for users as to whether the Terminal Equipment complies with the additional requirements for the Public Switched Telephone Network specified in this Advisory Note for Germany, Greece and Portugal.

Appendix A also specifies the method to assess compliance with the additional requirement, including reference to the additional tests to be performed to dynamically assess compliance with the additional requirements.

ATAAB

TRAC Analogue Type Approval Advisory Board

Appendix A

to

ATAAB Advisory Note Number: AN 06

Subject: Adding a second test-point to the test of the resistance to earth

A.1 INTRODUCTION

Terminal equipment approved to CTR 21 may not inter-work properly with the Public Switched Telephone Network in Germany, Greece and Portugal.

This Appendix specifies requirements to which a TE shall comply, in addition to the requirements of CTR 21 in order to ensure inter-working with the Public Switched Telephone Network in Germany, Greece and Portugal. It also specifies the method to assess compliance with these additional requirements, including reference to additional tests to be performed to dynamically assess compliance with the additional requirements.

A.2 NORMATIVE REFERENCES

[1] CTR 21; Terminal Equipment (TE). Attachment requirements for pan-European approval for connection to the analogue Public Switched Telephone Networks (PSTNs) of TE (excluding TE supporting the voice Telephony Service) in which network addressing, if provided, is by means of Dual Tone Multi-Frequency (DTMF) signalling.

NOTE: This document makes reference to CTR 21. Until CTR 21 is available, reference should be made to the base ETSI documents prTBR 21 (Sept 1997) or, when it is available, to TBR 21.

A.3 REQUIREMENTS and ASSOCIATED TESTS

NOTE: The following requirements are in addition to the requirements of CTR 21 Clause 4.4.4 and the associated tests in Clause A.4.4.4. The changes introduced by this Advisory Note extend the resistance-to-earth-testing to a second test-point at 150 V DC (Value ≥ 100 k Ω).

A.3.1 Resistance to earth (Requirement - Based on CTR 21: Clause 4.4.4)

Justification: 91/263/EEC, Article 4(f); Interworking with the PSTN is assured by requiring the TE to present a sufficiently high DC resistance to earth in the quiescent state to prevent the malfunction of network call control equipment. The PSTN in Germany, Greece and Portugal may not be capable of accepting a resistance to earth less than 100 k Ω at 150 V DC.

Requirement: Where the supplier's instructions state that a connection to earth is intended, the DC resistance between earth and each line terminal of the TE in quiescent states shall be not less than 10 M Ω when tested at 100 V DC and not less than 100 k Ω when tested at 150 V DC.

Test: The test shall be conducted according to A.3.2

A.3.2 Resistance to earth (Test - based on CTR 21: Clause A.4.4.4)

Requirement: Subclause A.3.1

Purpose: To avoid a resistance to earth less than 10 M Ω at 100 V DC and less than 100 k Ω at 150 V DC.

Measurement principle:

Preamble: Set the TE in quiescent state.

Test state: Quiescent state.

Test configuration:

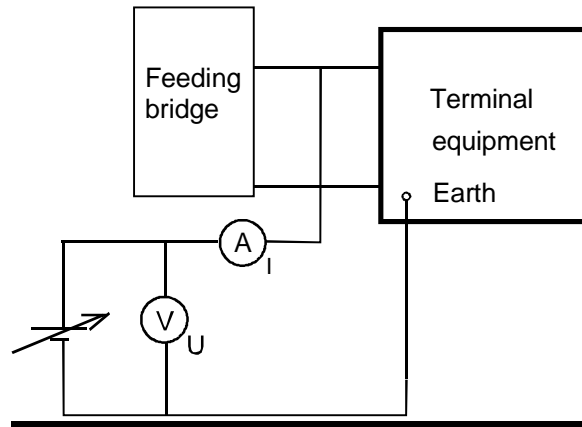

Figure A.7

DC feeding arrangement: Feed voltage: 50 V. Feed resistance: 230 Ω .

Measurement points: U = 100 V DC.
 U = 150 V DC.

Measurement execution:

Apply test voltage U between one of the line terminals and the earth connection point or points specified by the supplier's instructions for at least 30 s before measuring current I. The test shall be carried out both line terminals and for both polarities of the applied test voltages and applied feeding voltage.

Formal processing: Resistance to earth (R) = U / I.

Verdict: If R is greater than or equal to 10 M Ω at U = 100 V DC and if R is greater than or equal to 100 k Ω at U = 150 V DC then Pass; else Fail.

Guidance: None.

A.3.3 Requirements Table (CTR-RT)

The requirements table of CTR 21, Annex B is still applicable.

ATAAB ADVISORY NOTE

TRAC Analogue Type Approval Advisory Board

ATAAB Advisory Note Number: AN 07

Subject: Requirement regarding the Liberation of loop condition by the TE in the event of power failure.

APPLICABILITY

This note is applicable for Terminal Equipment intended for connection to the German, Portuguese and Spanish Public Switched Telephone Networks, in addition to:



" CTR 21" (When published)

NOTE: Until CTR 21 is available, reference should be made to ETSI document prTBR 21 (Sept 1997) or, when it is available, to TBR 21.

Appendix to this Advisory Note:

A: Additional requirements and tests for attachment to the German, Portuguese and Spanish PSTN

In consideration of the following:

- TE with external power supply, either in quiescent or loop state, might not be able to continue operation when that power supply is interrupted, or is out of its guaranteed limits.
- If the external power supply is interrupted or is out of its guaranteed limits, and the TE is in quiescent state, it should not initiate any function which is not able to terminate correctly with the external power supply interrupted.
- If the external power supply is interrupted or is out of its guaranteed limits, and the TE is in loop state, it should revert to quiescent state.
- If the TE is not able to revert to quiescent state in the presence of power failure, it might cause unjustified billing and/or unnecessary occupation of network resources.

ATAAB advises the following:

When in quiescent condition, Terminal Equipment connected to the Spanish, Portuguese and German PSTN and powered by external power supply (power supplies other than the PSTN itself), shall not initiate any function that is not able to terminate correctly with the power supply interrupted.

When in loop condition, Terminal Equipment connected to the Spanish PSTN and powered by external power supply (power supplies other than the PSTN itself), shall be able to revert to quiescent condition if that power supply is interrupted or is outside the limits necessary to permit the Terminal Equipment to continue to be compliant with CTR21.

TE approved to CTR 21 and intended for connection to the Spanish Portuguese and German Public Switched Telephone Network, shall, in addition to the requirements of CTR21, comply with the requirements found in Appendix A to this Advisory Note.

It is the responsibility of the supplier to provide information for users as to whether the Terminal Equipment complies with the additional requirements for the Spanish Portuguese and German Public Switched Telephone Network specified in this Advisory Note.

Appendix A also specifies the tests to assess compliance with this additional requirement.

ATAAB

TRAC Analogue Type Approval Advisory Board

Appendix A

to

ATAAB Advisory Note number: AN 07

Subject: Requirement regarding the Liberation of loop condition by the TE in the event of power failure

A.1 INTRODUCTION

In the event of power failure, Terminal Equipment, approved to CTR21, requiring power from a supply other than the PSTN may not work properly when connected to the German, Portuguese and Spanish Public Switched Telephone Network and in quiescent condition shall not initiate any function, which is not able to terminate correctly with its power supply interrupted.

In the event of power failure, Terminal Equipment, approved to CTR21, requiring power from a supply other than the PSTN may not work properly when connected to the German, Portuguese and Spanish Public Switched Telephone Network and TE in loop condition shall be able to revert to quiescent condition when the power supply is outside the limits necessary to permit the Terminal Equipment to remain compliant with CTR21.

This Appendix specifies requirements to which a TE shall comply, in addition to the requirements of CTR 21 to demonstrate that the TE reverts to quiescent condition in the event of power failure.

It also specifies the method to assess compliance with these additional requirements.

A.2 NORMATIVE REFERENCES

- [1] CTR21: Terminal Equipment (TE). Attachment requirements for pan-European approval for connection to the analogue Public Switched Telephone Networks (PSTNs) of TE (excluding TE supporting the voice Telephony Service) in which network addressing, if provided, is by means of Dual Tone Multi-Frequency (DTMF) signalling.

NOTE: This document makes reference to CTR21. Until CTR 21 is available, reference should be made to the base draft ETSI document prTBR 21 (June 1996), or when it is available, to TBR 21.

A.3 REQUIREMENTS AND ASSOCIATED TESTS

NOTE: The following requirements are in addition to the requirements of CTR 21 Clause 4.9 and its associated tests in A.4.9.

A.3.1 Liberation of Loop condition by the TE in the event of power failure (Requirement)

This requirement applies to TE that require power from supplies other than the PSTN in order to interwork with the PSTN.

Justification: 91/263/EEC, Article 4(f); Interworking with the PSTN is assured by requiring a TE that is unable to continue to comply with TBR 21 in the event of power failure to revert to the quiescent condition, thus avoiding unnecessary billing and occupation of network resources.

Requirement: A TE with external power supply shall revert to quiescent condition whenever that external power supply is interrupted or is outside the limits necessary to permit the Terminal Equipment to continue to be compliant with CTR21, within a time interval of 30s from the power interruption.

Compliance shall be checked by the tests outlined in section A.3.2

A.3.2 Liberation of Loop condition by the TE in the event of power failure (Test)

Requirement: A.3.1

Purpose: To verify that the TE, that has external power supply, reverts to its quiescent condition whenever that external power supply is interrupted or is outside the limits necessary to permit the Terminal Equipment to continue to be compliant with CTR21.

Measurement principle:

Preamble: Set the TE in loop state and make sure that the TE is powered with its external power supply according to the instructions manual.

Test state: Loop state

Test configuration:

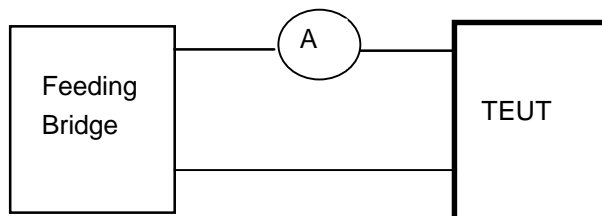

Figure A.3.1: Change to quiescent condition in the event of power failure

DC feeding arrangements: Feed voltage = 50 V. Feed resistance: 2 050 Ω.

Measurement points: Loss of power supply in loop condition

Measurement execution: Set the TE in its loop condition and power it with the external power supply in accordance with the instructions for use. After the TE has been in loop condition for 2s, disable the external power supply and then check:

- a) whether the TE has reverted to its quiescent state, according to requirement 4.9, by monitoring the DC current up to 30s after the power supply has been interrupted
- or
- b) whether the TE still continues operation, remaining in loop condition, by monitoring the DC current up to the minimum time necessary to achieve the function being performed by the TE at the moment of the power interruption, in accordance with the instructions for use.

Formal processing: None

Verdict: If the TE changes to its quiescent state according to requirement 4.9 within a time interval of 30s from the power interruption, or the TE keeps its loop state for the minimum time necessary to achieve the function that is performed at the moment of the interruption, according to the instructions for use, then Pass; else Fail.

Guidance: If the TE comes with a separate power adaptor, interrupt the power at the mains.

If the TE has a user battery, then remove the battery.

If the TE is capable of different kinds of operation, this test should be performed with the most power-consuming operation.

ATAAB ADVISORY NOTE

TRAC Analogue Type Approval Advisory Board

ATAAB Advisory Note Number: AN 09

Subject: Testing Instantaneous voltage in a wider frequency range

APPLICABILITY

This note is applicable for Terminal Equipment intended for connection to the German Public Switched Telephone Networks, in addition to:

" CTR 21" (When published)

NOTE: Until CTR 21 is available, reference should be made to ETSI document prTBR 21 (Sept 1997) or, when it is available, to TBR 21.

Appendix to this Advisory Note:

A: Additional requirements and tests for attachment to the German PSTN

In consideration of the following:

- Great values of instantaneous voltage will saturate the DTMF-receiver and therefore the network is unable to analyse the dialling-information.
- Because of the complete change of this requirement during the Resolution Meeting, this requirement could not have been considered during the public enquiry.
- Instantaneous voltage in frequency ranges, which are not tested in the current version of CTR21, may cause the loss of dialling information.
- The very low frequency ranges of instantaneous voltage from 200 Hz down to 5 Hz can be caused by internal switches in TEs, when switching from normal operation to DTMF-signalling. This can cause misinterpretation of the first digit by the DTMF-Receiver of the network.
- Higher frequency instantaneous voltage from 3800 Hz up to 4300 Hz can also effect the DTMF-Receiver because of the not ideal characteristic of the input filter of the DTMF-Receiver of the network.
- Not improving this requirement will cause wrong dialling in the German Network.

ATAAB advises the following:

The frequency range for testing instantaneous voltage should be extended to a range from 5 Hz to 4 300 Hz.

To ensure interworking with the German Public Switched Telephone Network, the TE shall, in addition to the requirements of CTR 21, comply with the requirements found in Appendix A of this Advisory Note.

It is the responsibility of the supplier to provide information for users as to whether the Terminal Equipment complies with the additional requirements for the German Public Switched Telephone Network specified in this Advisory Note.

Appendix A also specifies the method to assess compliance with the additional requirement, including reference to the additional tests to be performed to dynamically assess compliance with the additional requirements.

ATAAB

TRAC Analogue Type Approval Advisory Board

Appendix A

to

ATAAB Advisory Note Number: AN 09

Subject: Testing Instantaneous voltage in a wider frequency range

A.1 INTRODUCTION

Terminal equipment approved to CTR 21 may not interwork properly with the German Public Switched Telephone Network.

This Appendix specifies requirements to which a TE shall comply, in addition to the requirements of CTR 21 to ensure interwork with the German Public Switched Telephone Network. It also specifies the method to assess compliance with these additional requirements, including reference to additional tests to be performed to dynamically assess compliance with the additional requirements.

A.2 NORMATIVE REFERENCES

- [1] CTR 21; Terminal Equipment (TE). Attachment requirements for pan-European approval for connection to the analogue Public Switched Telephone Networks (PSTNs) of TE (excluding TE supporting the voice Telephony Service) in which network addressing, if provided, is by means of Dual Tone Multi-Frequency (DTMF) signalling.

NOTE: This document makes reference to CTR 21. Until CTR 21 is available, reference should be made to the base ETSI documents prTBR 21 (June 1996) or, when it is available, to TBR 21.

A.3 REQUIREMENTS and ASSOCIATED TESTS

A.3.1 General loop steady state requirements

NOTE: The following requirements are in addition to the requirements of CTR 21 Clause 4.7.3.2 and the associated tests in Clause A.4.7.3.2. The changes introduced by this Advisory Note extend the frequency range from 5 Hz to 4300 Hz.

A.3.1.1 Instantaneous voltage (Requirement - based on CTR 21: Clause 4.7.3.2)

Justification: 91/263/EEC, Article 4(d); Protection of the PSTN from harm is assured by limiting the signal sent into the PSTN by the TE so that the interfering effects of the signal can be predicted and avoided.

Requirement: The peak to peak voltage in the frequency range 5 Hz to 4300 Hz shall not exceed 5,0 V when the TE interface is terminated with the reference impedance Z_R .

Test: The test shall be conducted according to A.3.1.2.

A.3.1.2 Instantaneous voltage (Test - based on CTR 21: Clause A.4.7.3.2)

Requirement: Subclause A.3.1.1

Purpose: To check that the peak to peak voltage of the TE complies with subclause 4.7.3.2.

Measurement principle:

Preamble: Set the TE in loop state.

Test state: The TE shall be in loop state and sending representative signals.

Test configuration:

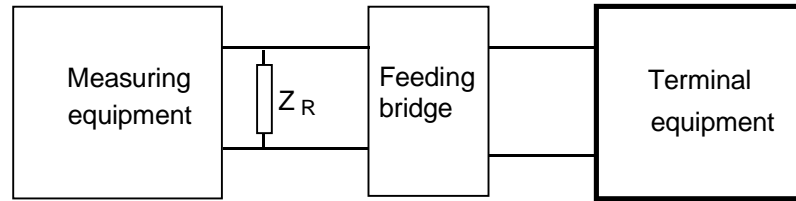

Figure A.14

DC feeding arrangement: Feed voltage: 50 V. Feed resistance: each of the following: 230 Ω and 3800 Ω . Polarity shall be switched between each feed resistance.

AC termination of TE: Z_R

Measurement points: The TE is exercised to send to the line:

- a) representative combinations of its declared output capabilities
- b) DTMF signals

Measurement execution:

The TE shall be set in the loop state, transmitting representative signals. The peak to peak voltage transmitted across the termination points of the TE, shall be measured.

Formal processing: None

Verdict: If the peak to peak voltage is not higher than 5,0 V in the frequency range 5 Hz to 4 300 Hz then Pass; else Fail.

Guidance: TE with adjustable output level is set up in accordance with supplier's instructions to send at its maximum intended level.

A.3.1.3 Requirements Table (CTR-RT)

The requirements table of CTR 21, Annex B is still applicable.

ATAAB ADVISORY NOTE

TRAC Analogue Type Approval Advisory Board

ATAAB Advisory Note Number: AN 10

Subject: Requirement regarding TBR15-levels in sending level requirements to protect the Public Switched Telephone Network in Germany from harm

APPLICABILITY

This note is applicable for Terminal Equipment intended for connection to the German Public Switched Telephone Networks, in addition to:



" CTR 21" (When published)

NOTE: Until CTR 21 is available, reference should be made to ETSI document prTBR 21 (Sept 1997) or, when it is available, to TBR 21.

Appendix to this Advisory Note:

A: Additional requirements and tests for attachment to the German PSTN

In consideration of the following:

- The requirements of TBR 15 fulfil the CCITT/ITU-T Recommendation V.2. This is the specification for the German PSTN and the international PSTN-gateways.
- The contracts between Deutsche Telekom and their international interconnection partners are based on V.2
- There is basically no gain-control in the German network
- There is no gain-control in the German network, which could adapt the frequency shape of TBR 21 approved terminals to the V.2 frequency shape at the interconnection points.
- Higher levels than allowed in TBR 15, especially at the high- and low-frequency ends of the voice-band, will affect pilot-tones of FDM-systems and the coding level of low bit rate coding TDM-systems.
- In accordance to the comment DE23 of the Public Enquiry this modification is proposed because otherwise sending levels higher than in TBR 15 will harm the PSTN of Deutsche Telekom AG and the international network.
- TBR15 was approved unanimously by ETSI, TRAC and ACTE. This gives a legal and fundamental basis for adopting the sending level values of TBR15 to TBR21. Therefore we should take the advantage of applying this harmonized requirements.

ATAAB advises the following:

The sending level limitations in the paragraphs 4.7.3.3 of TBR 21 must be identical with the sending level limitations in the paragraphs 4.2.2.2.3 of TBR 15:

To protect the international Public Switched Telephone Network and also Public Switched Telephone Network in Germany from harm, the TE shall comply with the improved sending level requirements as harmonized in TBR15.

It is the responsibility of the supplier to provide information for users as to whether the Terminal Equipment complies with the additional requirements for the German Public Switched Telephone Network specified in this Advisory Note.

Appendix A also specifies the tests according to that in detail.

ATAAB

TRAC Analogue Type Approval Advisory Board

Appendix A

to

ATAAB Advisory Note Number: AN 10

Subject: Requirement regarding TBR15-levels in sending level requirements to protect the Public Switched Telephone Network in Germany from harm

A.1 INTRODUCTION

Terminal equipment approved to CTR 21 may harm the German Public Switched Telephone Network.

This Appendix specifies requirements to which a TE shall comply, in addition to the requirements of CTR 21 to protect the German Public Switched Telephone Network from harm. It also specifies the method to assess compliance with these additional requirements, including reference to additional tests to be performed to dynamically assess compliance with the additional requirements.

A.2 NORMATIVE REFERENCES

- [1] CTR 21; Terminal Equipment (TE). Attachment requirements for pan-European approval for connection to the analogue Public Switched Telephone Networks (PSTNs) of TE (excluding TE supporting the voice Telephony Service) in which network addressing, if provided, is by means of Dual Tone Multi-Frequency (DTMF) signalling.

NOTE: This document makes reference to CTR 21. Until CTR 21 is available, reference should be made to the base ETSI documents prTBR 21 (Sept 1997) or, when it is available, to TBR 21.

- [2] CTR 15;.

A.3 REQUIREMENTS and ASSOCIATED TESTS

A.3.1 Voltage level in a 10 Hz bandwidth in loop state

NOTE: The following requirement is a change in a the requirement of CTR 21 Clause 4.7.3.3. The changes introduced by this Advisory Note replace Table 6 of TBR 21 by Table 3 of TBR 15. Accordingly to this changes the corresponding Figure is adapted.

Justification: 91/263/EEC, Article 4(d); Protection of the PSTN from harm is assured by limiting signal sent into the PSTN by the TE so that the interfering effects of the signal are limited to prevent harm to the national and international network.

Requirement: The voltage within a 10 Hz bandwidth centered at any point in the frequency band 30 Hz to 4 300 Hz, and wholly contained within that frequency band, shall not exceed the limits given in table 6 and figure 6 when the TE interface is terminated with the reference impedance Z_R . This requirement also applies to DTMF signals sent after dialling.

Table 6: Voltage in a 10 Hz bandwidth

Points	Frequency kHz	Sending level dBV
A	0,03	- 33,7
B	0,1	- 16,7
C	0,3	- 6,7
D	3,4	- 6,7
E	3,8	- 15,7
F	4,3	- 44,7

NOTE: Limits for intermediate frequencies can be found by drawing a straight line between the break points on a logarithmic (Hz) - linear (dB) scale.

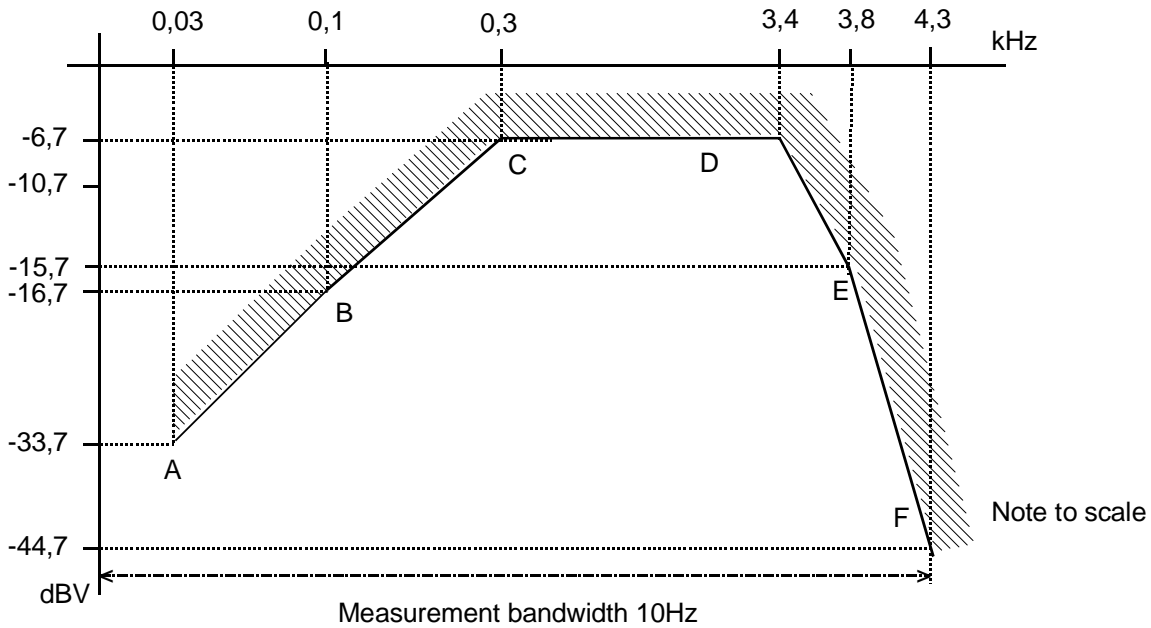

Figure 6: Voltage level in a 10 Hz bandwidth

Test: The test shall be conducted according to Annex A, subclause A.4.7.3.3.

A.3.2 Voltage level in a 10 Hz bandwidth in loop state

Requirement: Subclause A.4.7.3.3.

Purpose: To check that the TE complies with subclause A.4.7.3.3.

Measurement principle:

Preamble: Set the TE in loop state.

Test state: The TE shall be in loop state, and sending representative signals continuously.

Test configuration:

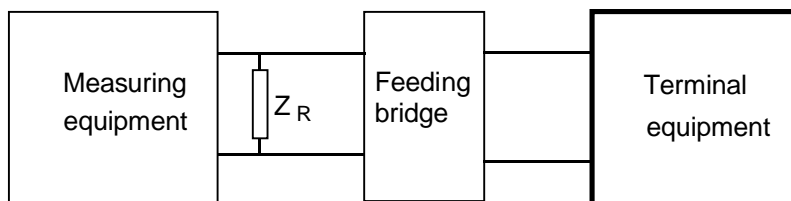

Figure A.15

DC feeding arrangement:

Feed voltage: 50 V. Feed resistance: each of the following: 230 Ω , and 3 200 Ω . Polarity shall be switched between each feed resistance.

AC termination of TE: Z_R

Measurement execution:

The TE shall be set in loop state, transmitting representative signals continuously. The voltage level transmitted across the TCP shall be measured. It shall be determined whether the level within every 10 Hz bandwidth wholly contained in the frequency range 30 Hz to 4 300 Hz is less than or equal to the limits given in table 6 and figure 6. In the case of data equipment (e.g. modems) the level shall only be measured during the data transfer phase.

Formal processing: None.

Verdict: If the levels are according to table 6 and figure 6 then Pass; else Fail.

Guidance: TE with adjustable output level is set up in accordance with the supplier's instructions to send at its maximum intended level.

A.3.3 Requirements Table (CTR-RT)

The requirements table of CTR 21, Annex B is still applicable.

ATAAB ADVISORY NOTE

TRAC Analogue Type Approval Advisory Board

ATAAB Advisory Note Number: AN 11

Subject: Requirement regarding establishment of loop for automatic answer

APPLICABILITY

This note is applicable for Terminal Equipment intended for connection to the Portuguese Public Switched Telephone Networks, in addition to:



" CTR 21" (When published)

NOTE: Until CTR 21 is available, reference should be made to ETSI document prTBR 21 (Sept 1997) or, when it is available, to TBR 21.

Appendix to this Advisory Note:

A: Additional requirements and tests for attachment to the Portuguese PSTN.

In consideration of the following:

- Terminal equipment must correctly interwork with the Portuguese PSTN as stated in Terminal Equipment Directive 91/263/EEC.
- Clause 4.5 of prTBR 21 tests the TE ringing signal detector sensibility by sending the ringing signal and waiting for the TE reaction during a time not specified.
- In the Portuguese PSTN, in some network exchanges, the ringing signal can be delivered to the TE for 2 min (if the call is not answered) and after that time the call is no more presented to that called party. This means that an automatic answering TE shall be able to respond to the ringing signal before this signal elapses.
- An automatic answering TE with a response to the ringing signal after 2 min may never answer to any call.

ATAAB advises the following:

Automatic answering terminal equipment connected to the Portuguese PSTN shall be able to answer to an incoming call during the delay of 2 min after the start of the application of the ringing signal to its terminals.

TE approved to CTR 21 and intended for connection to the Portuguese PSTN shall, in addition to the requirements of CTR 21, comply with the requirements found in Appendix A to this Advisory Note.

It is a supplier's responsibility to provide information for users as to whether the Terminal Equipment complies with the additional requirements for the Portuguese PSTN specified in this Advisory Note.

Appendix A also specifies the tests to assess compliance with the additional requirement.

ATAAB

TRAC Analogue Type Approval Advisory Board

Appendix A

to

ATAAB Advisory Note Number: AN 11

Subject: Requirement regarding establishment of loop for automatic answer

A.1 INTRODUCTION

Terminal equipment approved to CTR 21 may not interwork properly with the Portuguese PSTN.

This Appendix specifies requirements to which a TE shall comply, in addition to the requirements of CTR 21 in order to ensure interworking with the Portuguese PSTN. It also specifies the method to assess compliance with these additional requirements, including reference to additional tests to be performed to dynamically assess compliance with the additional requirements.

A.2 NORMATIVE REFERENCES

- [1] CTR 21; Terminal Equipment (TE). Attachment requirements for pan-European approval for connection to the analogue Public Switched Telephone Networks (PSTNs) of TE (excluding TE supporting the voice Telephony Service) in which network addressing, if provided, is by means of Dual Tone Multi-Frequency (DTMF) signalling.

NOTE: This document makes reference to CTR 21. Until CTR 21 is available, reference should be made to the base ETSI documents prTBR 21 (Sept 1997) or, when it is available, to TBR 21.

A.3 REQUIREMENTS AND ASSOCIATED TESTS

A.3.1 Ringing signal detector sensitivity

The following requirement is a change to Clause 4.5 of CTR 21 and to the associated tests in Clause A.4.5. The changes introduced by this Advisory Note limit the time given to the terminal to answer to the ringing signal, if the ringing detect function is provided.

The requirement of Clause 4.5 of CTR 21 shall read:

Requirement: If a ringing detect function is provided and enabled, the TE shall be able to respond to ringing signals of 30 Vrms at 25 Hz and 50 Hz with a cadence of 1 s ON and 5 s OFF, superimposed on a 50 VDC feeding bridge.

The terminal equipment shall respond as stated by the supplier and within a delay of 2 min after the start of the application of the ringing signal to the circuit.

Test: The test shall be conducted according to A.3.2.

A.3.2 Ringing signal detector sensitivity

The changes to Clause A.4.5 of CTR 21 shall be the following:

Requirement: Subclause A.3.1.

(...)

Measurement execution:

Using the test configuration shown in figure A.8, apply, one at a time, each one of the ringing signals described in "Measurement points" to the circuit to determine whether they are detected by the TE as stated by the supplier.

Formal processing: Measure the time elapsed between the start of the application of the ringing signal to the circuit and the TE response.

Verdict: If TE detects all the ringing signals above described in "Measurement points" and if the time measured above is < 2 min then "PASS"; else "FAIL".

ATAAB ADVISORY NOTE

TRAC Analogue Type Approval Advisory Board

ATAAB Advisory Note Number: AN 12

Subject: Requirement regarding transient after a change to the opposite polarity

APPLICABILITY

This note is applicable for Terminal Equipment intended for connection to the Spanish Public Switched Telephone Networks, in addition to:



" CTR 21" (When published)

NOTE: Until CTR 21 is available, reference should be made to ETSI document prTBR 21 (Sept 1997) or, when it is available, to TBR 21.

Appendix to this Advisory Note:

A: Additional requirements and tests for attachment to the Spanish PSTN

In consideration of the following:

- In the Spanish PSTN, whenever a call is established, when the called TE answers the call, the network either cuts the feeding current of the calling TE for a time, or alternatively, changes the polarity of the calling TE DC feeding voltage (which also implies a little cut in the DC feeding current).
- When the DC voltage has been changed to the opposite polarity, the loop state shall be maintained within certain limits of time and current, in order not to clear the line.
- The TE must be proved capable of supporting the change to the opposite polarity in the DC voltage and the cut of the DC current without clearing the line.

ATAAB advises the following:

Terminal equipments connected to the Spanish PSTN must be capable of keeping the line when the network changes the polarity of its feeding current.

TE approved to CTR 21 and intended for connection to the Spanish Public Switched Telephone Network, shall, in addition to the requirements of CTR21, comply with the requirements found in Appendix A to this Advisory Note.

Conformity to this additional requirements is subject to approval.

It is the responsibility of the supplier to provide information for users as to whether the Terminal Equipment complies with the additional requirements for the Spanish Public Switched Telephone Network specified in this Advisory Note.

Appendix A also specifies the tests to assess compliance with this additional requirement.

ATAAB

TRAC Analogue Type Approval Advisory Board

Appendix A

to

ATAAB Advisory Note Number: AN 12

Subject: Requirements regarding the susceptibility of the TE to the changes to the opposite polarity

A.1 INTRODUCTION

Terminal equipment approved to CTR 21 may not work properly when connected to the Spanish Public Switched Telephone Network, as the TE must be capable of supporting changes to the opposite polarity in the DC voltage and the implied line interruptions without clearing the line.

This Appendix specifies requirements to which a TE shall comply, in addition to the requirements of CTR 21 **in order to test that the TE can support changes to the opposite polarity from the network** for signalling purposes, keeping the line under certain limits of time and current.

It also specifies the method to assess compliance with these additional requirements.

A.2 NORMATIVE REFERENCES

- [1] CTR 21: Terminal Equipment (TE). Attachment requirements for pan-European approval for connection to the analogue Public Switched Telephone Networks (PSTNs) of TE (excluding TE supporting the voice Telephony Service) in which network addressing, if provided, is by means of Dual Tone Multi-Frequency (DTMF) signalling.

NOTE: This document makes reference to CTR21. Until CTR 21 is available, reference should be made to the base draft ETSI document prTBR 21 (Sept 1997), or when it is available, to TBR21.

A.3 REQUIREMENTS AND ASSOCIATED TESTS

NOTE: The following requirements are in addition to the requirements of CTR 21 Clause 4.7.1 and its associated tests in A.4.7.1.

A.3.1 Transient after a change to the opposite polarity (Requirement)

Justification: 91/263/EEC, Article 4(f); Interworking with the PSTN is assured by requiring the TE to support changes to the opposite polarity sent by the network, for signalling purposes in order to establish the call, without clearing the line.

Requirement: With the TE in loop condition, when it happens a change to the opposite polarity, the loop state shall be maintained in such a manner that the loop current shall comply with the limits according to the mask of figure A.3.1 where

- t_1 = instant in which the switch takes the new polarity
- $t_2 = t_1 + 3 \text{ ms}$
- $t_3 = t_1 + 10 \text{ ms}$
- I_1 = Stationary value of the loop current for the original polarity
- $I_2 = I_1 - 3 \text{ mA}$
- $I_3 = I_1 + 3 \text{ mA}$
- I_4 = Stationary value of the loop current for the new polarity
- $I_5 = I_4 + 3 \text{ mA}$
- $I_6 = I_4 - 3 \text{ mA}$
- $I_7 = 125 \text{ mA}$
- $I_8 = -125 \text{ mA}$
- $I_9 = -16 \text{ mA}$
- $I_{10} = -100 \text{ mA}$

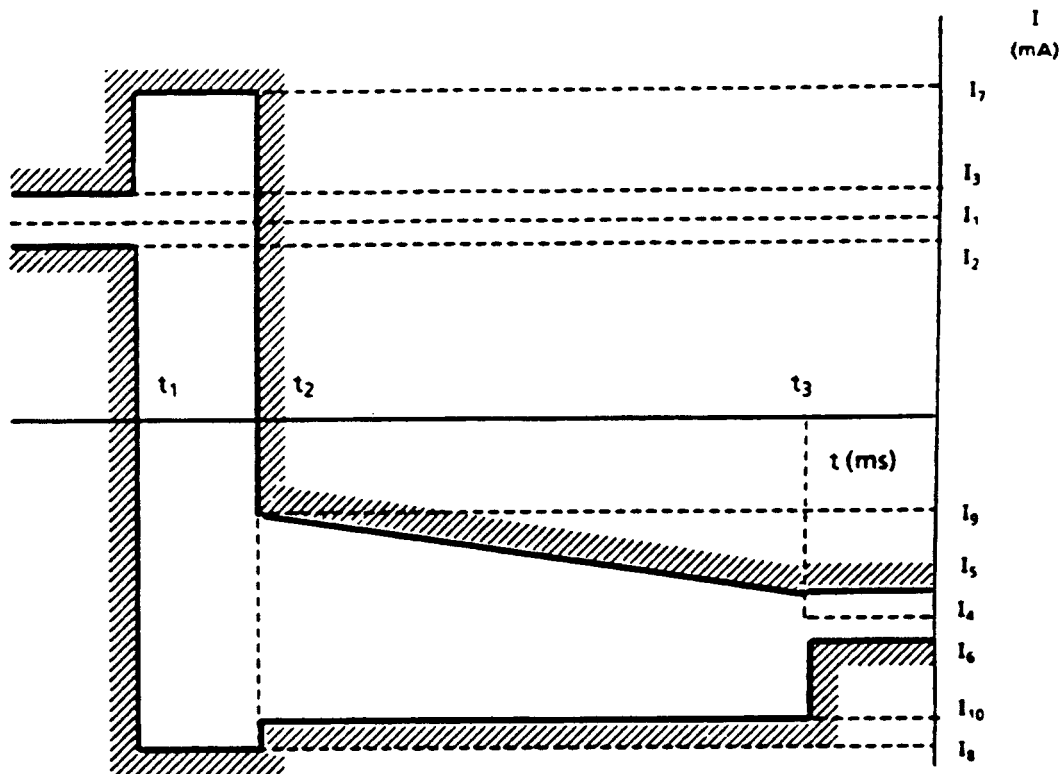

Figure A.3.1 Transient after a change to the opposite polarity

This requirement shall not be applied in those cases in which this signalling is used for clearing purposes.

Compliance shall be checked by the tests outlined in section A.3.2

A.3.2 Transient after a change to the opposite polarity (Test)

Requirement: A.3.1

Purpose: To verify that the TE is capable of keeping the line under certain conditions of time and current, after a change to the opposite polarity in the DC voltage.

Measurement principle:

Preamble: Set the TE in quiescent state

Test state: Loop state

Test configuration:

Figure A.3.2: Transient after a change to the opposite polarity

The TEUT is connected as shown in figure A.3.2.

The feeding voltages V_{f1} and V_{f2} , takes the value of 50 V. The two feeding resistors, R_{f1} and R_{f2} , take the value of 230 Ω ; the test shall also be made when these resistors take the value of 850 Ω .

A suitable instrument is used to document the loop current variations as consequence of the change of switch S_1 .

Measurement execution:

In sequence, select a feed resistance value according to the DC feeding arrangement and then cause the TE to enter the loop state after making sure that the TE has been held at least 1 minute in quiescent state. When the terminal has been in the loop state for at least

1,2 s, provoke a change to the opposite polarity by changing the position of switch S_1 .

The change of switch S_1 shall be done in a maximum time of 0,2 ms.

Allow sufficient setting time, to a maximum of 3 s, to ensure that the measured value is stable to within $\pm 0,5$ % for at least 0,2 s.

A suitable instrument is used to document the loop current variations as a consequence of the change of switch S_1 . Then repeat the sequence for other measurement points, repeating each time a transition from quiescent state to loop state.

Formal processing: None

Verdict: If, during the change of the position of the switch S_1 , the DC current has been within the time/current limits specified in figure A.3.1, then pass; else fail.

Guidance: Allowing "sufficient setting time" is useful to ensure test repeatability and reproducibility. Nevertheless if the stated stability cannot be found, the setting time shall be limited to 3s. In this latter case a measurement accuracy improvement may be obtained by averaging several measurement readings made during the setting time.

GERMAN ADVISORY NOTE

German Advisory Note Number: DE 03

Subject: Sending level in quiescent state to avoid interference with the German Public Switched Telephone Network

NOTE: The requirements in GR 03 and DE 03 are identical.

APPLICABILITY

This note is applicable for Terminal Equipment intended for connection to the German Public Switched Telephone Networks, in addition to:



" CTR 21" (When published)

NOTE: Until CTR 21 is available, reference should be made to ETSI document prTBR 21 (Sept 1997) or, when it is available, to TBR 21.

Appendix to this Advisory Note:

A: Additional requirements and tests for attachment to the German PSTN

In consideration of the following:

- The levels of any signals transmitted by a TE in the quiescent state need to be controlled in order for the effects to be predicted and, if necessary, avoided.
- The cumulative effect of a large number of TEs in quiescent state transmitting signals in excess of that permitted in the on-line state may affect the signal to noise ratio of other services using the same local distribution cable.
- The ability to deploy systems that deliver increased data rates over metallic local distribution cables requires a predictable minimum level of interference (assuming that no significant faults exist).

The German Regulatory Authority advises the following:

To protect the Public Switched Telephone Network in Germany from interference, the TE shall, in addition to the requirements of CTR 21, comply with the requirements found in Appendix A of this Advisory Note. Conformity to these additional requirements has to be assured by TE, intended for connection to the German PSTN.

Terminals connected to the German PSTN should not be permitted to send signals to the network in quiescent state that exceed the levels permitted in the on-line state.

It is the responsibility of the supplier to provide information for users as to whether the Terminal Equipment complies with the additional requirements for the Public Switched Telephone Network specified in this Advisory Note.

Appendix A also specifies the method to assess compliance with the additional requirement, including reference to the additional tests to be performed to dynamically assess compliance with the additional requirements

GERMAN ADVISORY NOTE

Appendix A

to

German Advisory Note Number: DE 03

Subject: control of sending level in quiescent state

A.1 INTRODUCTION

Terminal equipment approved to CTR 21 may interfere with the German Public Switched Telephone Network.

This Appendix specifies requirements to which a TE shall comply, in addition to the requirements of CTR 21 in order to prevent interference with the German Public Switched Telephone. It also specifies the method to assess compliance with these additional requirements, including reference to additional tests to be performed to dynamically assess compliance with the additional requirements.

A.2 NORMATIVE REFERENCES

- [1] CTR 21; Terminal Equipment (TE). Attachment requirements for pan-European approval for connection to the analogue Public Switched Telephone Networks (PSTNs) of TE (excluding TE supporting the voice Telephony Service) in which network addressing, if provided, is by means of Dual Tone Multi-Frequency (DTMF) signalling.

NOTE: This document makes reference to CTR 21. Until CTR 21 is available, reference should be made to the base ETSI documents prTBR 21 (June 1996) or, when it is available, to TBR 21.

A.3 REQUIREMENTS and ASSOCIATED TESTS

The sending level limitations contained in TBR 21 (Clause 4.7.3), applicable in the loop state, shall also apply when the TE is in the quiescent state and when performing functions, it would normally perform in the quiescent state.

Conformity shall be checked by carrying out the test of A.4.7.3 but with the TE in the quiescent state and stimulated, if necessary, to perform functions it would normally perform in the quiescent state which could influence the level of any signals presented by it to the PSTN interface.

GERMAN ADVISORY NOTE

German Advisory Note Number: DE 04

Subject: Inter-working after receiving ringing signals having a long duration

NOTE: The requirements in GR 04 and DE 04 are identical.

APPLICABILITY

This note is applicable for Terminal Equipment intended for connection to the German Public Switched Telephone Networks, in addition to:

"CTR 21" (When published)

NOTE: Until CTR 21 is available, reference should be made to ETSI document prTBR 21 (Sept 1997) or, when it is available, to TBR 21.

Appendix to this Advisory Note:

A: Additional requirements and tests for attachment to the German PSTN.

In consideration of the following:

- Ringing signals with a duration of up to 6.5 s can occur in some maintenance situations in the German PSTN.
- If a TE is not able to withstand this kind of ringing signal, it will impair its the capability to interwork properly.

The German Regulatory Authority advises the following:

To ensure interworking with the German Public Switched Telephone Network, the TE shall, in addition to the requirements of CTR 21, comply with the requirements found in Appendix A of this Advisory Note.

It is the responsibility of the supplier to provide information for users as to whether the Terminal Equipment complies with the additional requirements for the German Public Switched Telephone Network specified in this Advisory Note.

Appendix A also specifies the method to assess compliance with the additional requirement, including reference to the additional tests to be performed to dynamically assess compliance with the additional requirements.

GERMAN ADVISORY NOTE

Appendix A

to

German Advisory Note Number: DE 04

Subject: Inter-working after receiving ringing signals having a long duration

A.1 INTRODUCTION

Terminal equipment approved to CTR 21 may not inter-work properly with the German Public Switched Telephone Network.

This Appendix specifies requirements to which a TE shall comply, in addition to the requirements of CTR 21 to ensure inter-working with the German Public Switched Telephone Network. It also specifies the method to assess compliance with these additional requirements, including reference to additional tests to be performed to dynamically assess compliance with the additional requirements.

A.2 REFERENCES

- [1] CTR 21; Terminal Equipment (TE). Attachment requirements for pan-European approval for connection to the analogue Public Switched Telephone Networks (PSTNs) of TE (excluding TE supporting the voice Telephony Service) in which network addressing, if provided, is by means of Dual Tone Multi-Frequency (DTMF) signalling.

NOTE: This document makes reference to CTR 21. Until CTR 21 is available, reference should be made to the base ETSI documents prTBR 21 (Sept 1997) or, when it is available, to TBR 21.

A.3 REQUIREMENTS and ASSOCIATED TESTS

A.3.1 Characteristics of TE for ringing signals

NOTE: The following requirements are in addition to clause 4.4.2. of TBR21.

A.3.1.1 Ringing signal overload (Requirement - New Clause 4.4.2.4)

Justification: 91/263/EEC, Article 4(f); Inter-working with the PSTN is assured by requiring the TE to withstand a load caused by ringing signal with a duration up to 6,5 s. The German PSTN may not be capable of a proper interworking with TE's which cannot handle this kind of ringing signals.

Requirement: The terminal shall be tested with a DC-voltage of $U = 63 \text{ V}$ ($R_i = 140 \Omega$) and $U = 85 \text{ V}$ ($R_i = 1340 \Omega$), superimposed in each case by an AC voltage $U_{\text{eff}} = 75 \text{ V}$ (25 Hz). The duration of the load is 6,5 s. After the test the TE shall still fulfil all remaining requirements of this TBR.

NOTE: This kind of signal can occur in maintenance-procedures. Under German national regulations, if the TE would stop inter-working with the PSTN after such a signal, the operator would be liable for any loss of service.

Test: The test shall be conducted according to A.3.1.2

A.3.1.2 Ringing signal overload (Test - New Clause A 4.4.2.4)

Requirement: Subclause A.3.1.1

Purpose: To ensure interworking of TE after ringing signals up to 6,5 s.

Measurement principle:

Preamble: Set the TE in quiescent state with answering facility, if provided, enabled.

Test state: Quiescent state.

Test configuration:

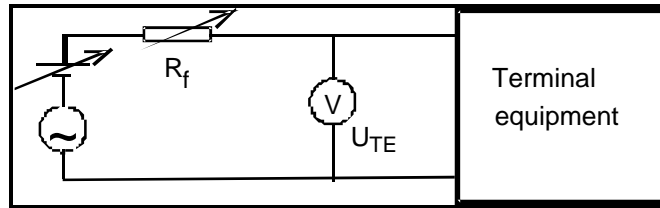

Figure A.8

DC feeding arrangement:

Feed voltage: 63 V. Feed resistance:
140 Ω . Feed voltage: 85 V.
Feed resistance: 1340 Ω .
Polarity shall be switched between each feed resistance.

Measurement points: The ringing signal has a sinusoidal source of 25 Hz and has duration of 6,5 s (on).

$$U_{TE \text{ eff}} = 75 \text{ V}$$

Safety Warning: This test presents the potential for a shock hazard. Ensure satisfactory safety precautions are implemented to reduce the risk of electric shock.

Measurement execution:

Send the ringing signal described above 2 times with a pause of 2 s in between.

Formal processing: None.

Verdict: If TE after this test complies with all other tests of CTR 21 then Pass; else Fail.

Guidance: This Test should be done as the first one, when testing a TE. For automatic answering, if the TE seizes the line during the application of the test ringing sequence, the sequence shall be completed, but the test-setup shall not be adjusted to compensate any reduction in $U_{TE \text{ eff}}$ which occurs as a result of seizure.

A.3.1.3 Requirements Table (CTR-RT)

The requirements table of CTR 21, Annex B is still applicable.

GERMAN ADVISORY NOTE

German Advisory Note Number: DE 05

Subject: Restriction on seizing the line without the intent of making a call

NOTE: The requirements in DE 05, GR 01 and P 08 are identical.

APPLICABILITY

This note is applicable for Terminal Equipment intended for connection to the German Public Switched Telephone Networks, in addition to:



" CTR 21" (When published)

NOTE: Until CTR 21 is available, reference should be made to ETSI document prTBR 21 (Sept 1997) or, when it is available, to TBR 21.

In consideration of the following:

- Dimensioning of the usable workload of the line-cards is based on the used network traffic.
- New dimensioning of the network or any other change of the network just for the introduction of a new technical regulation is out of the scope of TBR21.
- repeated automatically seizing the line without the intention of making a call could reduce the available workload of the line-card sufficiently to cause the loss of service to other customers.
- Seizing the line in order to use remote power, to check the availability of the line or to load a local battery may therefore cause loss of service to other customers, if this is repeated often and lasts long.
- Such loss of service does harm the PSTN and has to be avoided.
- Also the German PSTN may not be capable to guarantee a proper inter-working with such TEs after repeated seizing of the line.

The German Regulatory Authority advises the following:

Terminals connected to the PSTN must not do repeated automatically seizing the line without the intention to make a call.

Automatically seizure means seizure that is not under the direct control of the user, which he recognizes as a seizure.

TE approved to CTR 21 will need to meet these additional requirements when a TE is intended for connection to the Public Switched Telephone Network.

To protect the Public Switched Telephone Network in Germany from harm and to ensure proper inter-working, the TE shall, in addition to the requirements of CTR 21, comply with the requirements of this Advisory Note.

Conformity to these additional requirements has to be assured by TE, connected to the German PSTN.

It is the responsibility of the supplier to provide information for users as to whether the Terminal Equipment complies with the additional requirements for the Public Switched Telephone Network specified in this Advisory Note.

The conformity to this requirement shall be declared by the manufacturer.

GERMAN ADVISORY NOTE

German Advisory Note Number: DE 08

Subject: Lower limit of voltage in DC characteristics

APPLICABILITY

This note is applicable for Terminal Equipment intended for connection to the German Public Switched Telephone Networks, in addition to:



" CTR 21" (When published)

NOTE: Until CTR 21 is available, reference should be made to ETSI document prTBR 21 (Sept 1997) or, when it is available, to TBR 21.

Appendix to this Advisory Note:

A: Additional requirements and tests for attachment to the German PSTN

In consideration of the following:

- Because of the design of the installed line-cards of the PSTN in Germany a minimum voltage in loop state is required.
- TE not showing this minimum voltage in loop state to the network will not allow a correct inter-working with the PSTN.

The German Regulatory Authority advises the following:

The voltage/current characteristics of TE in the loop state shall provide a minimum voltage as described in Appendix A of this Advisory note.

To ensure inter-working with the German Public Switched Telephone Network, the TE shall, in addition to the requirements of CTR 21, comply with the requirements found in Appendix A of this Advisory Note.

It is the responsibility of the supplier to provide information for users as to whether the Terminal Equipment complies with the additional requirements for the German Public Switched Telephone Network specified in this Advisory Note.

Appendix A also specifies the method to assess compliance with the additional requirement, including reference to the additional tests to be performed to dynamically assess compliance with the additional requirements.

GERMAN ADVISORY NOTE

Appendix A

to

German Advisory Note Number: DE 08

Subject: Lower limit of voltage in DC characteristics

A.1 INTRODUCTION

Terminal equipment approved to CTR 21 may not interwork properly with the German Public Switched Telephone Network.

This Appendix specifies requirements to which a TE shall comply, in addition to the requirements of CTR 21 to ensure interwork with the German Public Switched Telephone Network. It also specifies the method to assess compliance with these additional requirements, including reference to additional tests to be performed to dynamically assess compliance with the additional requirements.

A.2 REFERENCES

- [1] CTR 21; Terminal Equipment (TE). Attachment requirements for pan-European approval for connection to the analogue Public Switched Telephone Networks (PSTNs) of TE (excluding TE supporting the voice Telephony Service) in which network addressing, if provided, is by means of Dual Tone Multi-Frequency (DTMF) signalling.

NOTE: This document makes reference to CTR 21. Until CTR 21 is available, reference should be made to the base ETSI documents prTBR 21 (Sept 1997) or, when it is available, to TBR 21.

A.3 REQUIREMENTS and ASSOCIATED TESTS

A.3.1 General loop steady state requirements

NOTE: The following requirements are in addition to the requirements of CTR 21 Clause 4.7.1 and the associated tests in Clause A.4.7.1. The changes introduced by this Advisory Note replaces the minimum voltage-values of 0 V by 5,4 V at the complete range of more than 20 mA current.

A.3.1.1 DC characteristics (Requirement - based on CTR 21: Clause 4.7.1)

Justification: 91/263/EEC, Article 4(f); Interworking with the European PSTN, some of which having different DC characteristics, is assured by requiring the TE to present a sufficiently low DC resistance in loop state.

Requirement: The DC voltage/current characteristics of the TE within the operating range as stated in clause 4.7 shall not exceed the limits given in table 5 and shown in figure 5.

Table 5: TE voltage/current characteristics

Point	Voltage (V)	Current (mA)
A	9,0	0
B	9,0	20,0
C	14,5	42,0
D	40,0	50,0
E	40,0	60,0
F	5,4	60,0
G	5,4	20,0
H	0	0
NOTE:	Limits for intermediate currents can be found by drawing a straight line between the break points on a linear voltage/current scale.	

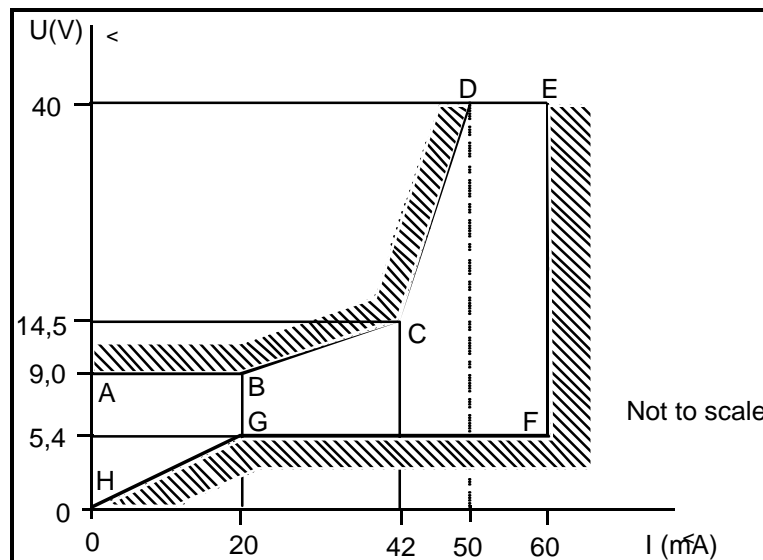

Figure 5: TE voltage/current characteristics

Test: The test shall be conducted according to Clause A.3.1.2.

A.3.1.2 DC characteristics (Test - based on CTR 21: Clause A.4.7.1)

Requirement: Subclause A.3.1.1

Purpose: To verify that the steady-state DC loop characteristics are within the limits given in table 5, and shown in figure 5. The test only applies to TE which are capable of reaching the loop state.

Measurement principle:

Preamble: Set the TE in quiescent state.

Test state: Loop state.

Test configuration:

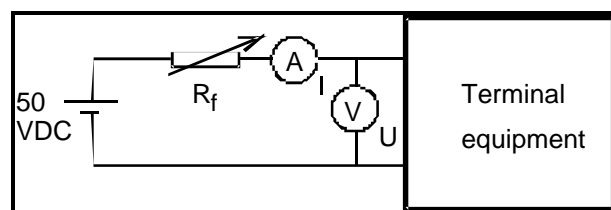

Figure A.11

DC feeding arrangement:

Feed voltage: 50 V;

Feed resistance: each of the following: 230 Ω , 850 Ω , 2 050 Ω and 3 200 Ω ; Polarity shall be switched between each feed resistance.

Measurement execution:

In sequence, select a feed resistance value according to the DC feeding arrangement and then cause the TE to enter the loop state after making sure that the TE has been held at least one minute in quiescent state. When the terminal has been in the loop state for at least 1,2 s, measure the DC current drawn by the TE and the DC voltage across the TE for each of the feed conditions. Allow sufficient settling time, to a maximum of 3 s, to ensure that the measured value is stable to within $\pm 0,5\%$ for at least 0,2 s. Then repeat the sequence for other measurement points, repeating each time a transition from quiescent state to loop state.

Formal processing: None.

Verdict: If the DC voltage/current characteristics are within the limits as given in table 5, and shown in figure 5 then Pass; else Fail.

Guidance: Allowing "sufficient settling time" is useful to ensure test repeatability and reproducibility. Nevertheless if the stated stability cannot be found, the settling time shall be limited to 3 s. In this latter case a measurement accuracy improvement may be obtained by averaging several measurement readings made during the settling time.

A.3.1.3 Requirements Table (CTR-RT)

The requirements table of CTR 21, Annex B is still applicable.

GERMAN ADVISORY NOTE

German Advisory Note Number: DE 09

Subject: Impedance during DTMF signalling

APPLICABILITY

This note is applicable for Terminal Equipment intended for connection to the German Public Switched Telephone Networks, in addition to:



" CTR 21" (When published)

NOTE: Until CTR 21 is available, reference should be made to ETSI document prTBR 21 (Sept 1997) or, when it is available, to TBR 21.

Appendix to this Note:

A: Additional requirements and tests for attachment to the German PSTN

In consideration of the following:

- For the German network, return loss of at least 14 dB against ZR is necessary between 600 Hz and 1 700 Hz when performing DTMF signalling to the network.
- This value could be expected where the TE presents a complex impedance close to ZR, even if a value of only 8 dB against ZR, as required by TBR21, is measured in the range from 300 Hz to 4 000 Hz.
- However, this might not be the case, if other impedance characteristics apply. (For example only resistive (real) impedance.).
- Not achieving a 14 dB return loss in the band between 600 Hz and 1 700 Hz could cause incorrect dialling in the German network

Germany advises the following:

For the frequency range from 600 Hz to 1 700 Hz, the impedance during DTMF dialling should be measured separately and comply with the requirements in Appendix A of this advisory Note.

To ensure inter-working with the German Public Switched Telephone Network, the TE shall, in addition to the requirements of CTR 21, comply with the requirements found in Appendix A of this Advisory Note.

It is the responsibility of the supplier to provide information for users as to whether the Terminal Equipment complies with the additional requirements for the German Public Switched Telephone Network specified in this Advisory Note.

Appendix A also specifies the method to assess compliance with the additional requirement, including reference to the additional tests to be performed to dynamically assess compliance with the additional requirements.

GERMAN ADVISORY NOTE

Appendix A

to

German Advisory Note Number: DE 09

Subject: Impedance during DTMF signalling

A.1 INTRODUCTION

Terminal Equipment approved to CTR 21 may not inter-work properly with the German Public Switched Telephone Network.

This Appendix specifies requirements to which a TE shall comply, in addition to the requirements of CTR 21 to ensure interwork with the German Public Switched Telephone Network. It also specifies the method to assess compliance with these additional requirements, including reference to additional tests to be performed to dynamically assess compliance with the additional requirements.

A.2 REFERENCES

- [1] CTR 21; Terminal Equipment (TE). Attachment requirements for pan-European approval for connection to the analogue Public Switched Telephone Networks (PSTNs) of TE (excluding TE supporting the voice Telephony Service) in which network addressing, if provided, is by means of Dual Tone Multi-Frequency (DTMF) signalling.

NOTE: This document makes reference to CTR 21. Until CTR 21 is available, reference should be made to the base ETSI documents prTBR 21 (Sept 1997) or, when it is available, to TBR 21.

A.3 REQUIREMENTS and ASSOCIATED TESTS

A.3.1 General loop steady state requirements

NOTE: The following requirements are in addition to the requirements of CTR 21 Clause 4.7.2 and the associated tests in Clause A.4.7.2.

A.3.1.1 Impedance (Requirement - based on CTR 21: Clause 4.7.2)

Justification: 91/263/EEC, Article 4(f); Inter-working with the PSTN is assured by requiring the TE to present an impedance which allows proper functioning of call control.

Requirement: during DTMF dialling the return loss calculated with respect to the reference impedance Z_R (at the same frequency) shall not be less than 14 dB at frequencies greater than 600 Hz but less than or equal 1 700 Hz.

Test: The test shall be conducted according to A.3.1.2.

A.3.1.2 Impedance (Test - based on CTR 21: Clause A.4.7.2)

Requirement: Subclause A.3.1.1

Purpose: To verify that the return loss of the input impedance of the TE (Z_i) in relation to the reference impedance Z_R is within the limits specified below.

Measurement principle:

Preamble: Set the TE in loop state and, either signalling DTMF-digits or presenting the impedance that would be presented during DTMF-signalling.

Test state: Loop state.

Test configuration:

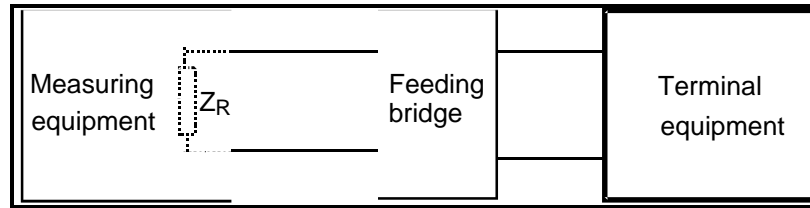

Figure A.12

DC feeding arrangement:

Feed voltage: 50 V. Feed resistance: each of the following: 230 Ω, 850 Ω, 2 050 Ω, and 3 200 Ω. Polarity shall be switched between each feed resistance.

AC termination of TE: Z_R

Measurement points:

The test signal shall be sinusoidal with a constant voltage, whose level shall be pre-set to that required to achieve a level of -10 dBV at the TE terminals.

$f_{\min} = 600$ Hz, $f_{\max} = 1\,700$ Hz with step intervals of not more than 1/3 of an octave.

Measurement execution:

When the TE has been in the loop state for at least 1,2 s, measure modulus of the voltage and current flowing at the measurement frequency. Calculate the complex impedance (Z_i) of the TE.

Formal processing: Return loss $a = 20 \log_{10} \left| \frac{Z_R + Z_i}{Z_R - Z_i} \right|$ where Z_R is the reference impedance and Z_i is the impedance of the TE.

Verdict: If the return loss is greater than or equal to 14 dB;
then Pass; else Fail.

Guidance: None.

A.3.1.3 Requirements Table (CTR-RT)

The requirements table of CTR 21, Annex B is still applicable.

GERMAN ADVISORY NOTE

German Advisory Note Number: DE 12

Subject: Improvement of Output signal balance for better DTMF signalling

APPLICABILITY

This note is applicable for Terminal Equipment intended for connection to the German Public Switched Telephone Networks, in addition to:



" CTR 21" (When published)

NOTE: Until CTR 21 is available, reference should be made to ETSI document prTBR 21 (Sept 1997) or, when it is available, to TBR 21.

Appendix to this Advisory Note:

A: Additional requirements and tests for attachment to the German PSTN

In consideration of the following:

- Low output signal balance will lead to a bad signal to noise ratio.
- With bad signal to noise ratio the network is not able to detect proper DTMF-tones.

The German Regulatory Authority advises the following:

The output signal balance in Table 8 of paragraph 4.7.4.2 of prTBR 21 shall be modified as described in Appendix A of this Advisory Note.

To ensure inter-working with the German Public Switched Telephone Network, the TE shall, in addition to the requirements of CTR 21, comply with the requirements found in Appendix A of this Advisory Note.

It is the responsibility of the supplier to provide information for users as to whether the Terminal Equipment complies with the additional requirements for the German Public Switched Telephone Network specified in this Advisory Note.

Appendix A also specifies the method to assess compliance with the additional requirement, including reference to the additional tests to be performed to dynamically assess compliance with the additional requirements.

GERMAN ADVISORY NOTE

Appendix A

to

German Advisory Note Number: DE 12

Subject: Improvement of Output signal balance for better DTMF signalling

A.1 INTRODUCTION

Terminal equipment approved to CTR 21 may not interwork properly with the German Public Switched Telephone Network.

This Appendix specifies requirements to which a TE shall comply, in addition to the requirements of CTR 21 to ensure interworking with the German Public Switched Telephone Network. It also specifies the method to assess compliance with these additional requirements, including reference to additional tests to be performed to dynamically assess compliance with the additional requirements.

A.2 REFERENCES

- [1] CTR 21; Terminal Equipment (TE). Attachment requirements for pan-European approval for connection to the analogue Public Switched Telephone Networks (PSTNs) of TE (excluding TE supporting the voice Telephony Service) in which network addressing, if provided, is by means of Dual Tone Multi-Frequency (DTMF) signalling.

NOTE: This document makes reference to CTR 21. Until CTR 21 is available, reference should be made to the base ETSI documents prTBR 21 (Sept 1997) or, when it is available, to TBR 21.

A.3 REQUIREMENTS and ASSOCIATED TESTS

A.3.1 General loop steady state requirements

NOTE: The following requirements are in addition to the requirements of CTR 21 Clause 4.7.4.2 and the associated tests in Clause A.4.7.4.2. The changes introduced by this Advisory Note complete the output signal balance-Table with increased values for DTMF dialling.

A.3.1.1 Output Signal Balance (Requirement - based on CTR 21: Clause 4.7.4.2)

Requirement: Where the supplier's instructions state that a connection to earth is intended, the Output Signal Balance when the AC termination of the TE is $600\ \Omega$ shall be at least the values given in table 8 and figure 8. This requirement only applies at frequencies where the unbalance level exceeds $-70\ \text{dBV}$ with the test method shown in clause A.4.7.4.2.

Table 8: Output Signal Balance and Longitudinal Conversion Loss, minimum values.

Frequency range	Minimum value
50 Hz to 300 Hz	30 dB
300 Hz to 600 Hz	46 dB
600 Hz to 3800 Hz	52 dB

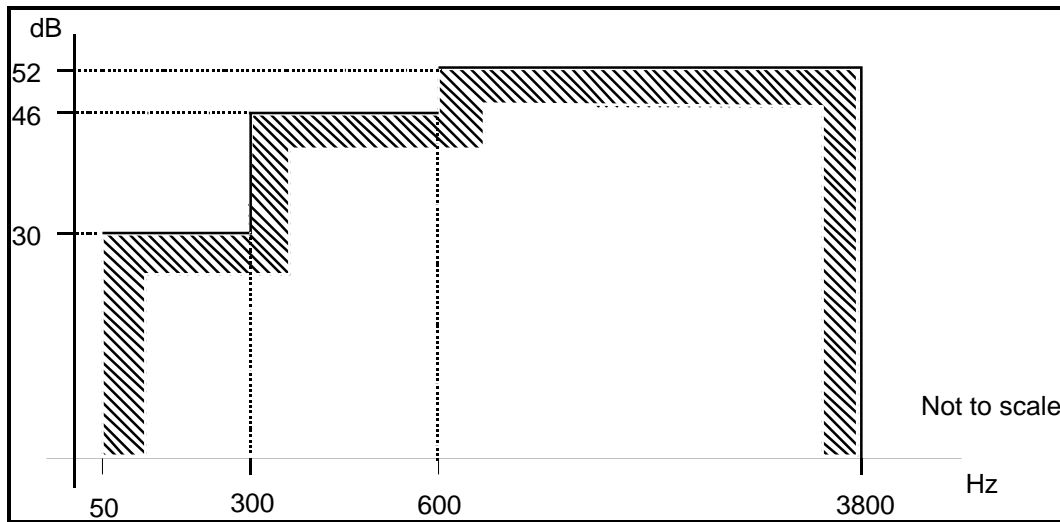

Figure 8: Output Signal Balance and Longitudinal Conversion Loss, minimum values.

Test: The test shall be conducted according to A.3.1.2.

A.3.1.2 Output Signal Balance (Test - based on CTR 21: Clause A.4.7.4.2)

Requirement: Subclause A.3.1.1

Purpose: To ensure that the impedance unbalance about earth, expressed as output signal balance, meets the requirements.

Measurement principle:

Preamble: Set the TE in loop state.

Test state: Loop state.

Test configuration:

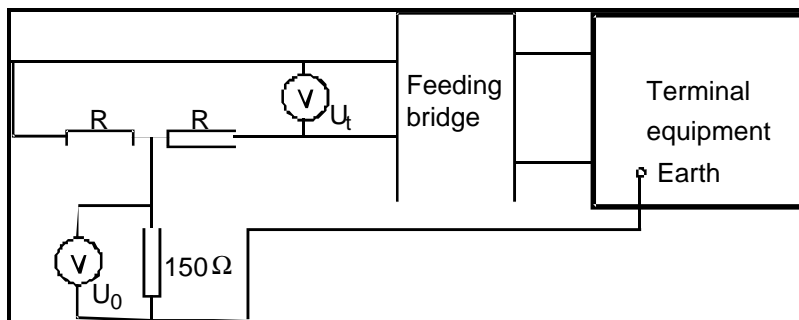

Figure A.19

DC feeding arrangement: Feed voltage: 50 V. Feed resistance: each of the following: 230 Ω , 850 Ω , 2 050 Ω and 3 200 Ω . Polarity shall be switched between each feed resistance.

Measurement points: The resistors R shall be 300 Ω . Measurement of the voltages U_0 and U_t shall be performed with a suitable frequency selective voltage measuring instrument.

Measurement execution:

The TE is set in the loop state transmitting representative signals to line.

Formal processing: The measured values of U_0 and U_t are used to calculate the Output Signal Balance by using the following equation:

$$\text{Output Signal Balance} = 20 \log_{10} \left| \frac{U_t}{U_0} \right| \text{dB}$$

For frequencies at which U_0 is less than -70 dBV the OSB is not calculated.

Verdict: If the Output Signal Balance is greater than the specified limit in table 8 and figure 8 then Pass; else Fail. For frequencies at which U_0 is less than -70 dBV there is no OSB requirement.

Guidance: The voltmeter input impedance should be greater than $100 \text{ k}\Omega$.

A.3.1.3 Requirements Table (CTR-RT)

The requirements table of CTR 21, Annex B is still applicable.

GERMAN ADVISORY NOTE

German Advisory Note Number: DE 14

Subject: Improvement for transition from loop to quiescent

APPLICABILITY

This note is applicable for Terminal Equipment intended for connection to the German Public Switched Telephone Networks, in addition to:



" CTR 21" (When published)

NOTE: Until CTR 21 is available, reference should be made to ETSI document prTBR 21 (Sept 1997) or, when it is available, to TBR 21.

Appendix to this Advisory Note:

A: Additional requirements and tests for attachment to the German PSTN

In consideration of the following:

- The clearing of the line by the TE, which is not understood correctly by the Network causes unjustified billing or unnecessary occupying of network resources.
- In TBR 21, the current drawn by the TE in the first 30 s after releasing the call is only restricted to a value, which is 10 times higher than specified for the German PSTN.
- TEs fulfilling just the minimum values of TBR 21 will remain in loop state up to 30 s longer than necessary and therefore not inter-work correctly with the PSTN.

The German Regulatory Authority advises the following:

Replace in the 1st tilde of the paragraph "Transition from loop to quiescent state" the values "0,5 mA" by "0,05 mA" and "200 ms" by "1 s"
and accordingly in the 2nd tilde also
"0,5 mA" by "0,05 mA"

To ensure inter-working with the German Public Switched Telephone Network, the TE shall, in addition to the requirements of CTR 21, comply with the requirements found in Appendix A of this Advisory Note.

It is the responsibility of the supplier to provide information for users as to whether the Terminal Equipment complies with the additional requirements for the German Public Switched Telephone Network specified in this Advisory Note.

Appendix A also specifies the method to assess compliance with the additional requirement, including reference to the additional tests to be performed to dynamically assess compliance with the additional requirements.

GERMAN ADVISORY NOTE

Appendix A

to

German Advisory Note Number: DE 14

Subject: Improvement for transition from loop to quiescent

A.1 INTRODUCTION

Terminal equipment approved to CTR 21 may not inter-work properly with the German Public Switched Telephone Network.

This Appendix specifies requirements to which a TE shall comply, in addition to the requirements of CTR 21 to ensure inter-working with the German Public Switched Telephone Network. It also specifies the method to assess compliance with these additional requirements, including reference to additional tests to be performed to dynamically assess compliance with the additional requirements.

A.2 REFERENCES

- [1] CTR 21; Terminal Equipment (TE). Attachment requirements for pan-European approval for connection to the analogue Public Switched Telephone Networks (PSTNs) of TE (excluding TE supporting the voice Telephony Service) in which network addressing, if provided, is by means of Dual Tone Multi-Frequency (DTMF) signalling.

NOTE: This document makes reference to CTR 21. Until CTR 21 is available, reference should be made to the base ETSI documents prTBR 21 (Sept 1997) or, when it is available, to TBR 21.

A.3 REQUIREMENTS and ASSOCIATED TESTS

NOTE: The following requirements are in addition to the requirements of CTR 21 Clause 4.9 and the associated tests in Clause A.4.9. The changes introduced by this Advisory Note replace the current drawn value 0,5 mA by 0,05 mA and the time value 200 ms by 1 s.

A.3.1 Transition from loop to quiescent state (Requirement - based on CTR 21: Clause 4.9)

Justification: 91/263/EEC, article 4(f); Interworking with the PSTN is assured by requiring the TE to correctly release the line.

Requirement : When the TE is connected to a source of 50 V DC in series with a resistor of 2,05 kOhm and initiates the transition from the loop to the quiescent state in order to release a call, the current drawn by the TE shall

- a) drop to a value below 0,05 mA not later than 1 s after the reference moment of the release and
- b) in the case of automatic release and subsequent automatic reseizure for the purposes of making a new call, remain below a value of 0,05 mA for a minimum of a further 1.5 s. In this case, it is permitted for there to be transient periods during which the current exceeds 0,05 mA, so long as, when aggregated, they do not exceed 20 ms.

The reference moment of the release is defined as the moment when, for the first time, the current has dropped to a value below 10mA, and has remained at a value below 10mA, for a period or periods which, when aggregated, exceed 20 ms.

NOTE 1: Clause 4.4 states the requirements for the quiescent state, including the d.c. resistance (subclause 4.4.1).

Test: The test shall be conducted according to A.3.2.

A.3.2 Transition from loop to quiescent state (Test - based on CTR 21: Clause A.4.9)

Requirement: Subclause A.3.1

Purpose: To determine, whether the TE changes correctly from the loop to the quiescent state.

Measurement principle:

Preamble: Set the TE to loop state and in the case of automatic procedures set the period which the TE will subsequently be in the quiescent state to its minimum value and activate the automatic procedure.

Test state: Cause the TE to make a transition to quiescent state.

Test configuration:

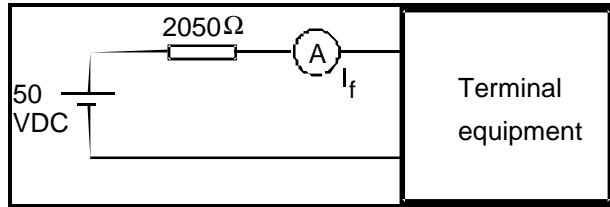

Figure A30

DC feeding arrangement: Feeding voltage 50 V DC.

Measurement points: Monitor the current I_f after it falls under 10 mA.

Measurement execution:

Cause the TE to make a transition from loop to quiescent state. Monitor the current drawn by the TE.

Formal Processing: None.

Verdict: If the TE complies with the limits of subclause 3.1 then Pass, else Fail.

Guidance: None.

A.3.2 Requirements Table (CTR-RT)

The requirements table of CTR 21, Annex B is still applicable.

GERMAN ADVISORY NOTE

German Advisory Note Number: DE 17

Subject: Definition of a feeding bridge

APPLICABILITY

This note is applicable for Terminal Equipment intended for connection to the German Public Switched Telephone Networks, in addition to:



" CTR 21" (When published)

NOTE: Until CTR 21 is available, reference should be made to ETSI document prTBR 21 (Sept 1997) or, when it is available, to TBR 21.

Appendix to this Advisory Note:

A: Definition of a feeding bride for real and reproducible test results

In consideration of the following:

- The assumption for an ideal feeding bridge could cause problems by different realizations in practical tests.
- This leads to discussion about the limits for an ideal terminal equipment and decides causally in some cases about the results "pass" or "fail".
- Under this conditions the results of the tests are not comparable and reproducible.

The German Regulatory Authority advises the following:

The feeding bridge should be explicitly defined as described in Appendix A.

GERMAN ADVISORY NOTE

Appendix A

to

German Advisory Note Number: DE 17

Subject: Definition of a feeding bridge

A.1 INTRODUCTION

Terminal equipment approved to CTR 21 may not inter-work properly with the German Public Switched Telephone Network.

This Appendix specifies requirements to which a TE shall comply, in addition to the requirements of CTR 21 in order to inter-work properly with the German Public Switched Telephone Network. It also specifies the method to assess compliance with these additional requirements, including reference to additional tests to be performed to dynamically assess compliance with the additional requirements.

A.2 REFERENCES

- [1] CTR 21; Terminal Equipment (TE). Attachment requirements for pan-European approval for connection to the analogue Public Switched Telephone Networks (PSTNs) of TE (excluding TE supporting the voice Telephony Service) in which network addressing, if provided, is by means of Dual Tone Multi-Frequency (DTMF) signalling.

NOTE: This document makes reference to CTR 21. Until CTR 21 is available, reference should be made to the base ETSI documents prTBR 21 (Sept 1997) or, when it is available, to TBR 21.

A.3 REQUIREMENTS and ASSOCIATED TESTS

NOTE: The following requirements are in addition to the requirements of CTR 21 Clause A.3. The changes introduced by this Advisory Note complete the specifications of a "non-ideal" feeding bridge by an insertion of a Table with the corresponding insertion loss-values.

A.3.1 Feeding bridge (Requirement - based on CTR 21: Clause A.3)

The feeding bridge specified in this Appendix is a configuration of test equipment used to:

- apply to the TE terminals electrical conditions consistent with those defined in the test
- suitably couple measurement equipment to the TE terminals

The insertion loss of the feeding bridge is specified in Table A.1,

- DC feeding and AC termination of the TE are as defined in the test
- All measurements are referenced to the TE terminals (e.g. the feeding bridge does not cause an attenuation or delay, in the parameter to be measured, between the TE terminals and the measuring equipment)

Table A.1: Insertion loss of the feeding bridge in Reference to the Termination Z_R

Frequency [Hz]	Maximum limit insertion loss [dB]
10	2
20	2
20	1
100	1
100	0.1
10 000	0.1

If requested by the supplier (e.g. for TE with an adaptive filter) the TE shall be reset before repeating a test with a different feeding condition.

Within individual test cases, "AC termination of TE" defines the total AC impedance to be seen by the TE including all test equipment (feeding bridge, measuring equipment, reference impedance fixtures, etc.).

A.3.2 Requirements Table (CTR-RT)

The requirements table of CTR 21, Annex B is still applicable.

GREEK ADVISORY NOTE

Greek Advisory Note Number: GR 01

Subject: Restriction on seizing the line without the intent of making a call

NOTE: The requirements in DE05, GR01 and P 08 are identical.

APPLICABILITY

This note is applicable for Terminal Equipment intended for connection to the Greek Public Switched Telephone Networks, in addition to:



" CTR 21" (When published)

NOTE: Until CTR 21 is available, reference should be made to ETSI document prTBR 21 (Sept 1997) or, when it is available, to TBR 21.

In consideration of the following:

- Dimensioning of the usable workload of the line-cards is based on the used network traffic.
- New dimensioning of the network or any other change of the network just for the introduction of a new technical regulation is out of the scope of TBR21.
- repeated automatically seizing the line without the intention of making a call could reduce the available workload of the line-card sufficiently to cause the loss of service to other customers.
- Seizing the line in order to use remote power, to check the availability of the line or to load a local battery may therefore cause loss of service to other customers, if this is repeated often and lasts long.
- Such loss of service does harm the PSTN and has to be avoided.
- Also the Greek PSTN may not be capable to guarantee a proper inter-working with such TEs after repeated seizing of the line.

The Greek Regulatory Authority advises the following:

Terminals connected to the PSTN must not do repeated automatically seizing the line without the intention to make a call.

Automatically seizure means seizure that is not under the direct control of the user, which he recognizes as a seizure.

TE approved to CTR 21 will need to meet these additional requirements when a TE is intended for connection to the Public Switched Telephone Network.

To protect the Public Switched Telephone Network in Greece from harm and to ensure proper inter-working, the TE shall, in addition to the requirements of CTR 21, comply with the requirements of this Advisory Note.

Conformity to these additional requirements has to be assured by TE, connected to the Greek PSTN.

It is the responsibility of the supplier to provide information for users as to whether the Terminal Equipment complies with the additional requirements for the Public Switched Telephone Network specified in this Advisory Note.

The conformity to this requirement shall be declared by the manufacturer.

GREEK ADVISORY NOTE

Greek Advisory Note Number: GR 02

Subject: Requirement regarding testing of Terminal Equipment with loop-disconnect signalling

NOTE: The requirements in GR 02 and P 10 are identical.

APPLICABILITY

This note is applicable for Terminal Equipment intended for connection to the Greek Public Switched Telephone Networks, in addition to:

"CTR 21" (When published)

NOTE: Until CTR 21 is available, reference should be made to ETSI document prTBR 21 (Sept 1997) or, when it is available, to TBR 21.

Appendix to this Advisory Note:

Nil

In consideration of the following:

- Terminal equipment must correctly inter-work with the Greek PSTN as stated in Terminal Equipment Directive 91/263/EEC.
- Terminal equipment must not harm the Greek PSTN as stated in Terminal Equipment Directive 91/263/EEC.
- The Greek PSTN is supported in several different public switches and some of them only accept loop disconnect signalling.
- It is possible that a user, with a loop disconnect signalling telephone line, buys a terminal equipment with both (DTMF and loop disconnect) signalling systems and tries to connect such equipment to his line.
- prTBR 21 states that if other (than DTMF) signalling method is provided in the terminal and intended to be used in certain European countries, it shall be subject to appropriate national regulations in addition to this TBR.
- A terminal under the scope of TBR 21 and with loop disconnect signalling facility is considered as intended to be used in Greece if this terminal is put on the Greek
- market with such facility enabled.
- A terminal equipment with a loop disconnect signalling facility enabled and not approved may not inter-work with the Greek PSTN and may even harm the network.

The Greek Regulatory Authority advises the following:

Terminal equipment under the scope of TBR 21 and provided with a loop disconnect signalling facility, shall be subject to appropriate mandatory additional national regulations in respect of such facility and shall therefore be marked according to those national regulations in order to be put on the Greek market or connected to the Greek PSTN.

It is a supplier's responsibility to provide information for users as to whether the Terminal Equipment complies with the additional requirements for the Greek PSTN specified in this Advisory Note.

GREEK ADVISORY NOTE

Greek Advisory Note Number: GR 03

Subject: control of sending level in quiescent state

NOTE: The requirements in GR 03 and DE 03 are identical.

APPLICABILITY

This note is applicable for Terminal Equipment intended for connection to the Greek Public Switched Telephone Networks, in addition to:

" CTR 21" (When published)

NOTE: Until CTR 21 is available, reference should be made to ETSI document prTBR 21 (Sept 1997) or, when it is available, to TBR 21.

Appendix to this Advisory Note:

A: Additional requirements and tests for attachment to the Greek PSTN

In consideration of the following:

- The levels of any signals transmitted by a TE in the quiescent state need to be controlled in order for the effects to be predicted and, if necessary, avoided.
- The cumulative effect of a large number of TEs in quiescent state transmitting signals in excess of that permitted in the on-line state may affect the signal to noise ratio of other services using the same local distribution cable.
- The ability to deploy systems that deliver increased data rates over metallic local distribution cables requires a predictable minimum level of interference (assuming that no significant faults exist).

The Greek National Regulatory Authority advises the following:

To protect the Public Switched Telephone Network in Greece from interference, the TE shall, in addition to the requirements of CTR 21, comply with the requirements found in Appendix A of this Advisory Note. Conformity to these additional requirements has to be assured by TE, intended for connection to the Greek PSTN.

Terminals connected to the Greek PSTN should not be permitted to send signals to the network in quiescent state that exceed the levels permitted in the on-line state.

It is the responsibility of the supplier to provide information for users as to whether the Terminal Equipment complies with the additional requirements for the Public Switched Telephone Network specified in this Advisory Note.

Appendix A also specifies the method to assess compliance with the additional requirement, including reference to the additional tests to be performed to dynamically assess compliance with the additional requirements

GREEK ADVISORY NOTE

Appendix A

to

Greek Advisory Note Number: GR 03

Subject: control of sending level in quiescent state.

A.1 INTRODUCTION

Terminal equipment approved to CTR 21 may interfere with the Greek Public Switched Telephone Network.

This Appendix specifies requirements to which a TE shall comply, in addition to the requirements of CTR 21 in order to prevent interference with the Greek Public Switched Telephone. It also specifies the method to assess compliance with these additional requirements, including reference to additional tests to be performed to dynamically assess compliance with the additional requirements.

A.2 NORMATIVE REFERENCES

- [1] CTR 21; Terminal Equipment (TE). Attachment requirements for pan-European approval for connection to the analogue Public Switched Telephone Networks (PSTNs) of TE (excluding TE supporting the voice Telephony Service) in which network addressing, if provided, is by means of Dual Tone Multi-Frequency (DTMF) signalling.

NOTE: This document makes reference to CTR 21. Until CTR 21 is available, reference should be made to the base ETSI documents prTBR 21 (June 1996) or, when it is available, to TBR 21.

A.3 REQUIREMENTS and ASSOCIATED TESTS

The sending level limitations contained in TBR 21 (Clause 4.7.3), applicable in the loop state, shall also apply when the TE is in the quiescent state and when performing functions, it would normally perform in the quiescent state.

Conformity shall be checked by carrying out the test of A.4.7.3 but with the TE in the quiescent state and stimulated, if necessary, to perform functions it would normally perform in the quiescent state which could influence the level of any signals presented by it to the PSTN interface.

GREEK ADVISORY NOTE

Greek Advisory Note Number: GR 04

Subject: Inter-working after receiving ringing signals having a long duration.

NOTE: The requirements in GR 04 and DE 04 are identical.

APPLICABILITY

This note is applicable for Terminal Equipment intended for connection to the Greek Public Switched Telephone Networks, in addition to:

"CTR 21" (When published)

NOTE: Until CTR 21 is available, reference should be made to ETSI document prTBR 21 (Sept 1997) or, when it is available, to TBR 21.

Appendix to this Advisory Note:

A: Additional requirements and tests for attachment to the Greek PSTN.

In consideration of the following:

- Ringing signals with a duration of up to 6.5 s can occur in some maintenance situations in the Greek PSTN.

- If a TE is not able to withstand this kind of ringing signal, it will impair its the capability to interwork properly.

The Greek Regulatory Authority advises the following:

To ensure interworking with the Greek Public Switched Telephone Network, the TE shall, in addition to the requirements of CTR 21, comply with the requirements found in Appendix A of this Advisory Note.

It is the responsibility of the supplier to provide information for users as to whether the Terminal Equipment complies with the additional requirements for the Greek Public Switched Telephone Network specified in this Advisory Note.

Appendix A also specifies the method to assess compliance with the additional requirement, including reference to the additional tests to be performed to dynamically assess compliance with the additional requirements.

GREEK ADVISORY NOTE

Appendix A

to

Greek Advisory Note Number: GR 04

Subject: Inter-working after receiving ringing signals having a long duration.

A.1 INTRODUCTION

Terminal equipment approved to CTR 21 may not inter-work properly with the Greek Public Switched Telephone Network.

This Appendix specifies requirements to which a TE shall comply, in addition to the requirements of CTR 21 to ensure inter-working with the Greek Public Switched Telephone Network. It also specifies the method to assess compliance with these additional requirements, including reference to additional tests to be performed to dynamically assess compliance with the additional requirements.

A.2 REFERENCES

- [1] CTR 21; Terminal Equipment (TE). Attachment requirements for pan-European approval for connection to the analogue Public Switched Telephone Networks (PSTNs) of TE (excluding TE supporting the voice Telephony Service) in which network addressing, if provided, is by means of Dual Tone Multi-Frequency (DTMF) signalling.

NOTE: This document makes reference to CTR 21. Until CTR 21 is available, reference should be made to the base ETSI documents prTBR 21 (Sept 1997) or, when it is available, to TBR 21.

A.3 REQUIREMENTS and ASSOCIATED TESTS

A.3.1 Characteristics of TE for ringing signals

NOTE: The following requirements are in addition to clause 4.4.2. of TBR21.

A.3.1.1 Ringing signal overload (Requirement - New Clause 4.4.2.4)

Justification: 91/263/EEC, Article 4(f); Inter-working with the PSTN is assured by requiring the TE to withstand a load caused by ringing signal with a duration up to 6,5 s. The Greek PSTN may not be capable of a proper interworking with TE's which cannot handle this kind of ringing signals.

Requirement: The terminal shall be tested with a DC-voltage of $U = 63 \text{ V}$ ($R_i = 140 \Omega$) and $U = 85 \text{ V}$ ($R_i = 1340 \Omega$), superimposed in each case by an AC voltage $U_{\text{eff}} = 75 \text{ V}$ (25 Hz). The duration of the load is 6,5 s. After the test the TE shall still fulfil all remaining requirements of this TBR.

NOTE: This kind of signal can occur in maintenance-procedures. Under Greek national regulations, if the TE would stop inter-working with the PSTN after such a signal, the operator would be liable for any loss of service.

Test: The test shall be conducted according to A.3.1.2

A.3.1.2 Ringing signal overload (Test - New Clause A 4.4.2.4)

Requirement: Subclause A.3.1.1

Purpose: To ensure interworking of TE after ringing signals up to 6,5 s.

Measurement principle:

Preamble: Set the TE in quiescent state with answering facility, if provided, enabled.

Test state: Quiescent state.

Test configuration:

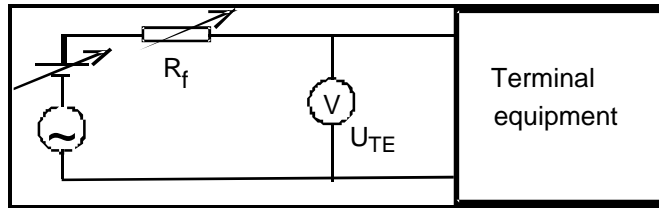

Figure A.8

DC feeding arrangement:

Feed voltage: 63 V. Feed resistance: 140 Ω .
 Feed voltage: 85 V. Feed resistance: 1340 Ω .
 Polarity shall be switched between each feed resistance.

Measurement points: The ringing signal has a sinusoidal source of 25 Hz and has duration of 6,5 s (on).

$U_{TE \text{ eff}} = 75 \text{ V}$

Safety Warning: This test presents the potential for a shock hazard. Ensure satisfactory safety precautions are implemented to reduce the risk of electric shock.

Measurement execution:

Send the ringing signal described above 2 times with a pause of 2 s in between.

Formal processing: None.

Verdict: If TE after this test complies with all other tests of CTR 21 then Pass; else Fail.

Guidance: This Test should be done as the first one, when testing a TE. For automatic answering, if the TE seizes the line during the application of the test ringing sequence, the sequence shall be completed, but the test-setup shall not be adjusted to compensate any reduction in $U_{TE \text{ eff}}$ which occurs as a result of seizure.

A.3.1.3 Requirements Table (CTR-RT)

The requirements table of CTR 21, Annex B is still applicable.

PORTUGUESE ADVISORY NOTE

Portuguese Advisory Note Number: P 03

Subject: Requirement regarding input impedance for voice band signals and billing signals in quiescent state.

APPLICABILITY

This note is applicable for Terminal Equipment intended for connection to the Portuguese Public Switched Telephone Networks, in addition to:



" CTR 21" (When published)

NOTE: Until CTR 21 is available, reference should be made to ETSI document prTBR 21 (Sept 1997) or, when it is available, to TBR 21.

Appendix to this Advisory Note:

A: Additional requirements and tests for attachment to the Portuguese PSTN.

In consideration of the following:

- Terminal equipment must correctly inter-work with the Portuguese PSTN as stated in Terminal Equipment Directive 91/263/EEC.
- The Portuguese PSTN, due to the rules applicable to the users telephone installation, allows several terminal equipments to be connected in parallel at the Network Termination Point.
- TBR21, in its Introduction section, states that "In an arbitrary combination of parallel and/or series connections, the performance of each individual terminal will need to be better than required by this TBR, to ensure satisfactory inter-working with the network.
- In a parallel connection it is necessary to guarantee that each connected terminal equipment in quiescent state has a sufficient high impedance for voice band signals in order not to interfere with another terminal connected on the same NTP and already in loop state in such a way that might
 - a) prevent the terminal in loop state from receiving signalling sent by the Portuguese PSTN (i.e. 12 kHz pulses or ringing signals);
 - b) prevent a voice telephony terminal in loop state from receiving voice sent by the Portuguese PSTN;
 - c) prevent the Portuguese PSTN from receiving signalling sent by the terminal in loop state, namely DTMF signals;
 - d) prevent the Portuguese PSTN from receiving signalling sent by a voice telephony terminal in loop state.

The Portuguese Regulatory Authority advises the following:

Terminal equipment in quiescent state shall present at its input terminals an input impedance with an absolute value not lower than 15 k Ω for signals with an AC voltage up to 1,5 Vrms and frequencies in the band frequency of 300 Hz – 4 000 Hz, and with an absolute value not lower than 6 k Ω for signals with an AC voltage up to 1,5 Vrms and frequencies in the band frequency of 4 kHz – 15 kHz.

TE approved to CTR 21 and intended for connection to the Portuguese PSTN shall, in addition to the requirements of CTR21, comply with the requirements found in Appendix A to this Advisory Note.

It is a supplier's responsibility to provide information for users as to whether the Terminal Equipment complies with the additional requirements for the Portuguese PSTN specified in this Advisory Note.

Appendix A also specifies the tests to assess compliance with the additional requirement.

PORTUGUESE ADVISORY NOTE

Appendix A

To

Portuguese Advisory Note Number: P 03

Subject: Requirement regarding input impedance for voice band signals and billing signals in quiescent state.

A.1 INTRODUCTION

Terminal equipment approved to CTR 21 may not interwork properly with the Portuguese PSTN.

This Appendix specifies requirements to which a TE shall comply, in addition to the requirements of CTR 21 in order to ensure interworking with the Portuguese PSTN. It also specifies the method to assess compliance with these additional requirements, including reference to additional tests to be performed to dynamically assess compliance with the additional requirements.

A.2 NORMATIVE REFERENCES

- [1] CTR 21; Terminal Equipment (TE). Attachment requirements for pan-European approval for connection to the analogue Public Switched Telephone Networks (PSTNs) of TE (excluding TE supporting the voice Telephony Service) in which network addressing, if provided, is by means of Dual Tone Multi-Frequency (DTMF) signalling.

NOTE: This document makes reference to CTR 21. Until CTR 21 is available, reference should be made to the base ETSI documents prTBR 21 (Sept 1997) or, when it is available, to TBR 21.

A.3 REQUIREMENTS AND ASSOCIATED TESTS

A.3.1 Input impedance in quiescent state for voice band and 12 kHz signals

NOTE: The following requirement is in addition to Clause 4.4 of CTR 21 and to the associated tests in Clause A.4.4.

Justification: 91/263/EEC, Article 4(f); Interworking with the Portuguese PSTN is assured by requiring the TE to present a sufficient high input impedance in quiescent state to signals sent by the Portuguese PSTN or by other terminal equipment in loop state connected on the same NTP.

Requirement: Terminal equipment in quiescent state shall present at its input terminals an input impedance with an absolute value not lower than 15 k Ω for signals with an AC voltage up to 1,5 Vrms and frequencies in the band frequency of 300 Hz - 4 000 Hz, and with an absolute value not lower than 6 k Ω for signals with an AC voltage up to 1,5 Vrms and frequencies in the band frequency of 4 kHz - 15 kHz.

Test: The test shall be conducted according to A.3.2.

A.3.2 Input impedance in quiescent state for voice band and 12 kHz signals

Requirement: Subclause A.3.1.

Purpose: To verify that the input impedance to voice band signals and to 12 kHz signals in quiescent state complies with the limits stated in A.3.1.

Measurement principle:

Preamble: Set the TE in quiescent state.

Test state: Quiescent state.

Test configuration: the same as Figure A.3 of prTBR21.

DC feeding arrangement: Feed Voltage = 50 V DC.

AC feeding arrangement: 1) Sinusoidal source $U_0 = 1,5$ V rms, frequency varying from 300 Hz to 4 kHz in order to measure U_{TE} across the TE.
2) Sinusoidal source $U_0 = 1,5$ V rms, frequency varying from 4 kHz to 15 kHz in order to measure U_{TE} across the TE.

Measurement points: Voltage U_{TE} and current I_{TE1} and I_{TE2} .

Safety Warning:

Measurement execution:

Using the test configuration shown, apply (one at a time), each one of the signals described in "AC feeding arrangement" to the circuit. Adjust the voltage (U_0) to set the voltage across the TE (U_{TE}) to 1,5 V rms. Measure the current I_{TE1} flowing in the circuit with sinusoidal source 1) and the current I_{TE2} flowing in the circuit with sinusoidal source 2).

Formal processing: The impedance of the TE can be calculated using the formulas

$$|Z_{Ri1}| = U_{TE} / I_{TE1}$$

$$|Z_{Ri2}| = U_{TE} / I_{TE2}$$

Verdict: If $|Z_{Ri1}|$ is equal or greater than 15 k Ω and if $|Z_{Ri2}|$ is equal or greater than 6 k Ω then "PASS"; else "FAIL".

A.3.3 Requirements Table (CTR-RT)

The requirements table of CTR 21, Annex B is still applicable.

PORTUGUESE ADVISORY NOTE

Portuguese Advisory Note Number: P 04

Subject: Requirements applicable to a terminal equipment with another port to connect a terminal equipment indirectly to the NTP in series/parallel with the terminal under test (Series Terminal Equipment).

APPLICABILITY

This note is applicable for Terminal Equipment intended for connection to the Portuguese Public Switched Telephone Networks, in addition to:



" CTR 21" (When published)

NOTE: Until CTR 21 is available, reference should be made to ETSI document prTBR 21 (Sept 1997) or, when it is available, to TBR 21.

Appendix to this Advisory Note:

A: Additional requirements and tests for attachment to the Portuguese PSTN.

In consideration of the following:

- As stated in Terminal Equipment Directive 91/263/EEC, terminal equipment must correctly interwork with the Portuguese PSTN and must also correctly inter-work via the Portuguese PSTN in case of a justified case service.
- The design of the telephone installation in the user premises allows more than one terminal equipment to be connected in series/parallel at the Network Termination Point.
- prTBR21, in its Introduction section, states that "In an arbitrary combination of parallel and/or series connections, the performance of each individual terminal will need to be better than required by this TBR, to ensure satisfactory inter-working with the network.
- prTBR 21 is applicable also to terminal equipment having another port for connection of a second TE (i.e. a telephone), as declared by the manufacturer, which then must inter-work properly with the Portuguese PSTN and even continue to guarantee inter-working between TEs in case of a justified telephony service.
- In a series connection where the terminal equipment directly connected to the NTP has a second port enabling the establishment of a telephony justified case service, it is necessary to guarantee that the terminal equipment directly connected shall not introduce
 - 1) an excessive series DC resistance therefore preventing the secondary port to provide the necessary feeding conditions to the TE connected at that port, thus disabling a justified case service to take place;
 - 2) an excessive delay in the provision of the necessary feeding conditions to the TE connected to the secondary port, in case the loop state is maintained by the associated TE;
 - 3) an excessive insertion loss for voice signals, therefore preventing the secondary port to provide a justified case service as declared by the manufacturer.

The Portuguese Regulatory Authority advises the following:

Terminal equipment having a secondary port to connect a second terminal equipment in series/parallel to the same NTP of the Portuguese PSTN shall, in addition to the requirements of CTR21, comply with the requirements found in Appendix A of this Advisory Note.

It is a supplier's responsibility to provide information for users as to whether the Terminal Equipment complies with the additional requirements for the Portuguese PSTN specified in this Advisory Note.

Appendix A also specifies the tests to assess compliance with these additional requirements

PORTUGUESE ADVISORY NOTE

Appendix A

To

Portuguese Advisory Note Number: P 04

Subject: Requirements applicable to a terminal equipment with a secondary port to connect a terminal equipment indirectly to the NTP in series/parallel with the terminal under test (Series Terminal Equipment).

A.1 INTRODUCTION

Terminal equipment approved to CTR 21 may not inter-work properly with the Portuguese PSTN.

This Appendix specifies requirements to which a TE shall comply, in addition to the requirements of CTR 21 in order to ensure inter-working with the Portuguese PSTN. It also specifies the method to assess compliance with these additional requirements, including reference to additional tests to be performed to dynamically assess compliance with the additional requirements.

A.2 DEFINITIONS

For the purpose of the requirements below, the following definitions apply:

Series Terminal Equipment (Series TE): a terminal equipment:

- directly connected to the Portuguese PSTN and with a secondary port for connection of a secondary terminal equipment;
- not enabled to maintain the loop state or the quiescent state in the NTP;
- designed to allow the loop state or the quiescent state in the NTP to be imposed and/or maintained by the secondary terminal equipment;
- considered in the loop state when the secondary TE is in the loop state;
- considered in the quiescent state when the secondary TE is in the quiescent state.

Insertion loss: The loss between the port connected to the NTP and the secondary port, for the frequencies in the voice frequency band.

A.3 NORMATIVE REFERENCES

- [1] CTR 21; Terminal Equipment (TE). Attachment requirements for pan-European approval for connection to the analogue Public Switched Telephone Networks (PSTNs) of TE (excluding TE supporting the voice Telephony Service) in which network addressing, if provided, is by means of Dual Tone Multi-Frequency (DTMF) signalling.

NOTE: This document makes reference to CTR 21. Until CTR 21 is available, reference should be made to the base ETSI documents prTBR 21 (Sept 1997) or, when it is available, to TBR 21.

A.4 REQUIREMENTS AND ASSOCIATED TESTS

A.4.1 Series DC resistance in loop state

NOTE: The following requirement is in addition to Clause 4.7 of CTR 21 and to the associated tests in Clause A.4.7.

Justification: 91/263/EEC, Article 4(f); Inter-working with the Portuguese PSTN is assured by requiring the Series TE to present a sufficient low DC series resistance in loop state.

Requirement: Series Terminal Equipment, when in the loop state, shall be responsible for the introduction of a DC resistance lower than 100 Ω .

Test: The test shall be conducted according to A.4.4.

A.4.2 Transition from quiescent to loop state

NOTE: The following requirement is in addition to Clause 4.6 of CTR 21 and to the associated tests in Clause A.4.6.

Justification: 91/263/EEC, Article 4(f); Inter-working with the Portuguese PSTN is assured by requiring the Series TE to present a sufficient low transition delay from quiescent to loop state.

Requirement: Series Terminal Equipment shall not introduce a delay higher than 100 ms in the transition from quiescent to loop state when the secondary TE changes from quiescent to loop state.

Test: The test shall be conducted according to A.4.5.

A.4.3 Insertion loss of a Series Terminal Equipment

NOTE: The following requirement is in addition to Clause 4.7 of CTR 21 and to the associated tests in Clause A.4.7.

Justification: 91/263/EEC, Article 4(f); Inter-working with the Portuguese PSTN is assured by requiring the Series TE to present a sufficient low insertion loss.

Requirement: Series Terminal Equipment in loop state shall not introduce an insertion loss worst than 1 dB for AC signals with 1,5 V rms in the frequency band of 300 Hz to 3400 Hz.

Test: The test shall be conducted according to A.4.6.

A.4.4 Series DC resistance in loop state (Test for A.4.1 requirement)

Requirement: Subclause A.4.1.

Purpose: To verify that the Series DC resistance of the Series Terminal Equipment, when in the loop state, shall be lower than 100 Ω .

Measurement principle:

Preamble: Set the TE in quiescent state.

Test state: Loop state.

Test configuration:

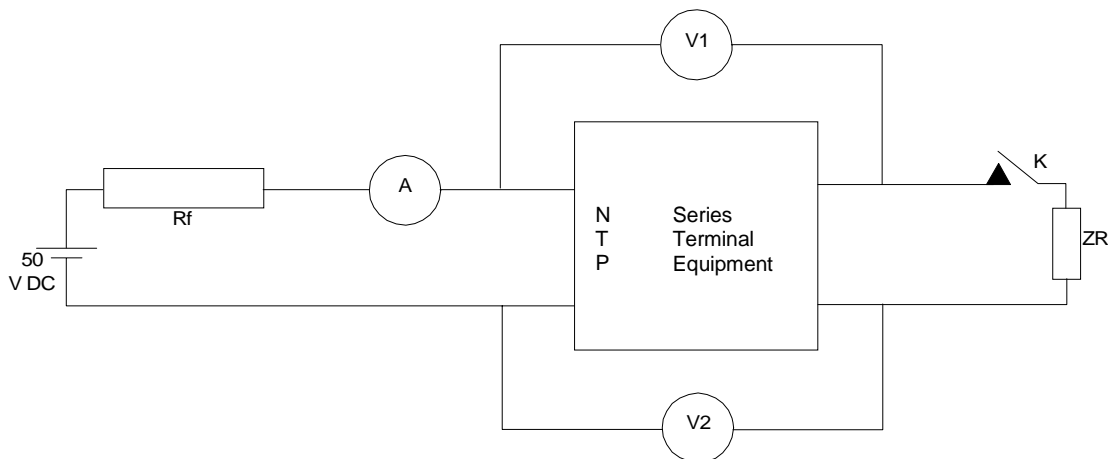

Figure A.3.1

DC feeding arrangement: Feed Voltage = 50 V DC. Feed resistance: each of the following 230 Ω , 850 Ω , 2 050 Ω and 3 200 Ω . Switch K is initially set to OFF. Polarity shall be changed between each feed resistance.

Measurement execution: Switch K is set to ON. Measure the voltage v_1 in voltmeter V_1 , the voltage v_2 in voltmeter V_2 and the current I in instrument A .

Formal processing: The series DC resistance of the TE can be calculated using the formula:

$$(v1 + v2) / I$$

Verdict: If the series DC resistance is lower than 100 Ω , then “pass”; else “fail”.

A.4.5 Transition from quiescent to loop state (Test for A.4.2 requirement)

Requirement: Subclause A.4.2.

Purpose: To verify that the transition from quiescent to loop state is performed by the Series Terminal Equipment within a delay lower than 100 ms.

Measurement principle:

Preamble: Set the TE in quiescent state.

Test state: Loop state.

Test configuration: See Figure A.3.1.

DC feeding arrangement: Feed Voltage = 50 V DC. Feed resistance: each of the following 230 Ω , 850 Ω , 2 050 Ω and 3 200 Ω . Switch K is initially set to OFF. Polarity shall be changed between each feed resistance.

Measurement execution: Switch K is set to ON. Monitor the current I and the voltages v1 and v2. Measure the voltage v1 in voltmeter V1, the voltage v2 in voltmeter V2 and the current I in instrument A, 100 ms after having switched K to ON.

Formal processing: Calculate the series DC resistance of the TE using the formula:

$$(v1 + v2) / I$$

Verdict: If the series DC resistance is lower than 100 Ω , then “pass”; else “fail”.

A.4.6 Insertion loss of a Series Terminal Equipment (Test for A.4.3 requirement)

Requirement: Subclause A.4.3.

Purpose: To verify that the Series Terminal Equipment in loop state doesn't introduce an insertion loss in the circuit worst than 1 dB, for AC signals with 1,5 V rms in the frequency band of 300 Hz to 3400 Hz.

Measurement principle:

Preamble: Set the TE in loop state.

Test state: Loop state.

Test configuration:

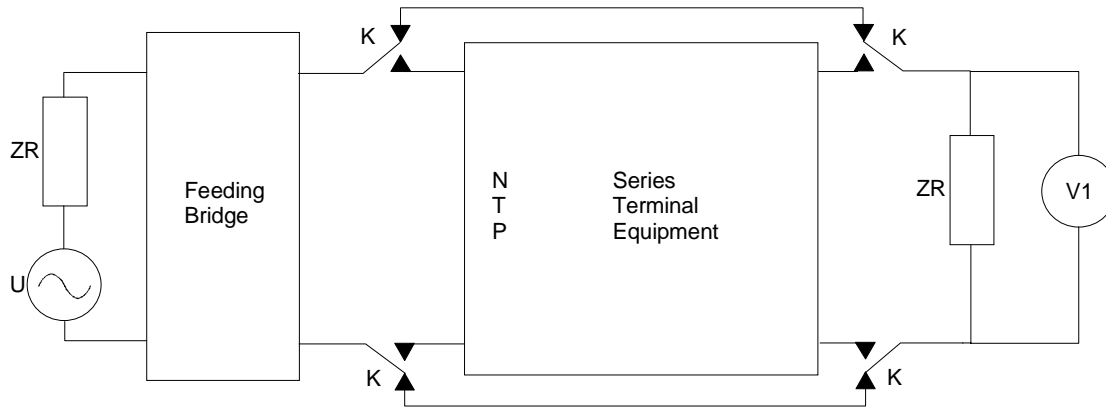

Figure A.3.2

DC feeding arrangement: Feed Voltage = 50 V DC. Feed resistance: each of the following 230 Ω , 850 Ω , 2 050 Ω and 3 200 Ω . Switch K is initially set to OFF, as shown on Figure A.3.2.

Measurement points: U shall be a sinusoidal signal with a constant voltage of 1,5 V rms throughout the specified range frequency of 300 Hz to 3400 Hz. Measurement of the voltage v1 across the secondary port charge ZR shall be performed with a suitable frequency selective voltmeter V1.

Measurement execution:

With K set to OFF, measure voltage v1OFF at the voltmeter V1 on the frequency range specified. Allow sufficient setting time at each feed condition to ensure stability of the measured value within $\pm 0,5\%$ for at least 0,2 s. Then set K to the position ON. Measure the voltage v1ON at the voltmeter V1 on the frequency range specified, using the procedure above.

Formal processing: Calculate insertion loss using the formula

$$\text{Insertion Loss} = 20 \cdot \log_{10} |v1ON / v1OFF| \text{ (dB)}$$

Verdict: If the calculated Insertion Loss is less than 1 dB in all the frequency range specified, then "pass"; else "fail".

PORTUGUESE ADVISORY NOTE

Portuguese Advisory Note Number: P 08

NOTE: This is identical to the requirements in DE 05.

Subject: Restriction on seizing the line without the intent of making a call.

NOTE: The requirements in DE05, GR01 and P 08 are identical.

APPLICABILITY

This note is applicable for Terminal Equipment intended for connection to the Portuguese Public Switched Telephone Networks, in addition to:



" CTR 21" (When published)

NOTE: Until CTR 21 is available, reference should be made to ETSI document prTBR 21 (Sept 1997) or, when it is available, to TBR 21.

In consideration of the following:

- Dimensioning of the usable workload of the line-cards is based on the used network traffic.
- New dimensioning of the network or any other change of the network just for the introduction of a new technical regulation is out of the scope of TBR21.
- repeated automatically seizing the line without the intention of making a call could reduce the available workload of the line-card sufficiently to cause the loss of service to other customers.
- Seizing the line in order to use remote power, to check the availability of the line or to load a local battery may therefore cause loss of service to other customers, if this is repeated often and lasts long.
- Such loss of service does harm the PSTN and has to be avoided.
- Also the Portuguese PSTN may not be capable to guarantee a proper inter-working with such TEs after repeated seizing of the line.

The Portuguese Regulatory Authority advises the following:

Terminals connected to the PSTN must not do repeated automatically seizing the line without the intention to make a call.

Automatically seizure means seizure that is not under the direct control of the user, which he recognizes as a seizure.

TE approved to CTR 21 will need to meet these additional requirements when a TE is intended for connection to the Public Switched Telephone Network in Portugal.

To protect the Public Switched Telephone Network in Portugal from harm and to ensure proper inter-working, the TE shall, in addition to the requirements of CTR 21, comply with the requirements of this Advisory Note.

Conformity to these additional requirements has to be assured by TE, connected to the Portuguese PSTN.

It is the responsibility of the supplier to provide information for users as to whether the Terminal Equipment complies with the additional requirements for the Public Switched Telephone Network specified in this Advisory Note.

The conformity to this requirement shall be declared by the manufacturer.

PORTUGUESE ADVISORY NOTE

Portuguese Advisory Note Number: P 10

Subject: Requirement regarding testing of Terminal Equipment with loop-disconnect signalling

NOTE: The requirements in GR 02 and P 10 are identical.

APPLICABILITY

This note is applicable for Terminal Equipment intended for connection to the Portuguese Public Switched Telephone Networks, in addition to:



" CTR 21" (When published)

NOTE: Until CTR 21 is available, reference should be made to ETSI document prTBR 21 (Sept 1997) or, when it is available, to TBR 21.

Appendix to this Advisory Note:

Nil

In consideration of the following:

- Terminal equipment must correctly inter-work with the Portuguese PSTN as stated in Terminal Equipment Directive 91/263/EEC.
- Terminal equipment must not harm the Portuguese PSTN as stated in Terminal Equipment Directive 91/263/EEC.
- The Portuguese PSTN is supported in several different public switches and some of them only accept loop disconnect signalling.
- It is possible that a user, with a loop disconnect signalling telephone line, buys a terminal equipment with both (DTMF and loop disconnect) signalling systems and tries to connect such equipment to his line.
- prTBR 21 states that if other (than DTMF) signalling method is provided in the terminal and intended to be used in certain European countries, it shall be subject to appropriate national regulations in addition to this TBR.
- A terminal under the scope of TBR 21 and with loop disconnect signalling facility is considered as intended to be used in Portugal if this terminal is put on the Portuguese market with such facility enabled.
- A terminal equipment with a loop disconnect signalling facility enabled and not approved may not inter-work with the Portuguese PSTN and may even harm the network.

The Portuguese Regulatory Authority advises the following:

Terminal equipment under the scope of TBR 21 and provided with a loop disconnect signalling facility, shall be subject to appropriate mandatory additional national regulations in respect of such facility and shall therefore be marked according to those national regulations in order to be put on the Portuguese market or connected to the Portuguese PSTN.

It is a supplier's responsibility to provide information for users as to whether the Terminal Equipment complies with the additional requirements for the Portuguese PSTN specified in this Advisory Note.

SPANISH ADVISORY NOTE

Spanish Advisory Note Number: ES 01

Subject: Requirement regarding DC current and loop resistance

APPLICABILITY

This note is applicable for Terminal Equipment intended for connection to the Spanish Public Switched Telephone Networks, in addition to:

" CTR 21" (When published)

NOTE: Until CTR 21 is available, reference should be made to ETSI document prTBR 21 (Sept 1997) or, when it is available, to TBR 21.

Appendix to this Advisory Note:

A: Additional requirements and tests for attachment to the Spanish PSTN

In consideration of the following:

- Whenever a TE wants to establish a call, the network detects the establishment by increasing the current flow to the TE.
- It can be assured that the network will detect that increase of current flow whenever the current is greater than 18.5 mA.
- In order to maintain the call, the current flow must not be lower than 18,5 mA at any moment.

The Spanish Regulatory Authority advises the following:

Terminal equipment connected to the Spanish Public Switched Telephone Network must take from the network a current of at least 18,5 mA for proper inter-working.

TE approved to CTR 21 and intended for connection to the Spanish Public Switched Telephone Network, shall, in addition to the requirements of CTR21, comply with the requirements found in Appendix A to this Spanish Advisory Note.

It is the responsibility of the supplier to provide information to users as to whether the Terminal Equipment complies with the additional requirements for the Spanish Public Switched Telephone Network specified in this Advisory Note.

Appendix A also specifies the tests to assess compliance with this additional requirement.

SPANISH ADVISORY NOTE

Appendix A

to

Spanish Advisory Note number: ES 01

Subject: Requirement regarding DC current and loop resistance

A.1 INTRODUCTION

Terminal equipment approved to CTR 21 may not work properly when connected to the Spanish Public Switched Telephone Network, as the TE must drain a minimum current of 18,5 mA for proper inter-working.

This Appendix specifies requirements to which a TE shall comply, in addition to the requirements of CTR 21, in order to test that the current drained from the network is at any moment equal to or greater than 18,5 mA.

It also specifies the method to assess compliance with these additional requirements.

A.2 NORMATIVE REFERENCES

- [1] CTR 21; Terminal Equipment (TE). Attachment requirements for pan-European approval for connection to the analogue Public Switched Telephone Networks (PSTNs) of TE (excluding TE supporting the voice Telephony Service) in which network addressing, if provided, is by means of Dual Tone Multi-Frequency (DTMF) signalling.

NOTE: This document makes reference to CTR 21. Until CTR 21 is available, reference should be made to the base ETSI documents prTBR 21 (Sept 1997) or, when it is available, to TBR 21.

A.3 REQUIREMENTS AND ASSOCIATED TESTS

NOTE: The following requirements are in addition to the requirements of CTR 21 Clause 4.7.1 and its associated tests in A.4.7.1.

A.3.1 DC current and loop resistance (Requirement - Based on CTR 21 Clause 4.7.1)

Justification: 91/263/EEC, Article 4f; inter-working with the European PSTN, some of which having different DC characteristics, requires a TE to present a sufficiently low DC resistance in loop state.

Requirement: The DC voltage/current characteristics of the TE within the operating range as stated in subclause 4.7 shall not exceed the limits given in table A.3.1 and shown in figure A.3.1.

Table A.3.1 Voltage/current characteristics

Point	Voltage (V)	Current (mA)
A	7,4	0
B	7,4	20
C	14,5	42
D	40,0	50,0
E	40,0	60,0
F	0	60,0
G	0	0

NOTE: Limits for intermediate currents can be found by drawing a straight line between the break points on a linear voltage/current scale.

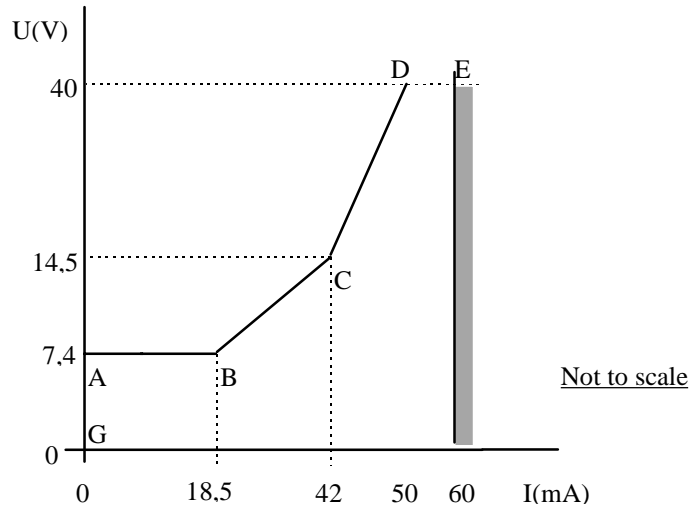

Figure A.3.1: TE voltage/current characteristics

A.3.2 DC current and loop resistance (Test - Based on CTR21:Clause A.4.7.1)

Requirement: A.3.1

Purpose: To verify that the steady-state DC loop characteristics are within the limits given in table A.3.1, and shown in figure A.3.1. The test only applies to TE which are capable of reaching the loop state.

Measurement principle:

Preamble: Set the TE in quiescent state.

Test state: Loop state.

Test configuration:

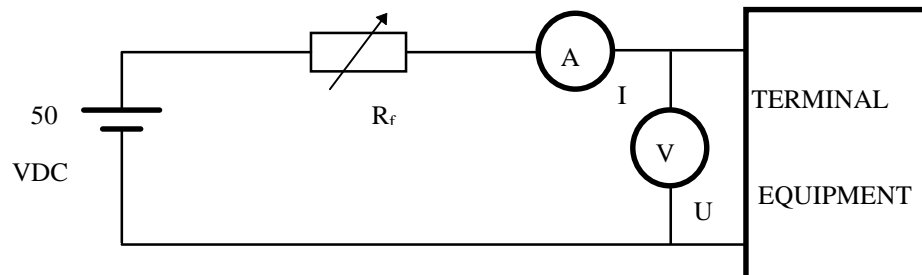

Figure A.3.2

DC feeding arrangements:

Feed voltage 50V. Feed resistance: each of the following: 230 Ω , 850 Ω , 2 050 Ω and 3 200 Ω . Polarity shall be switched between each feed resistance

Measurement execution:

In sequence, select a feed resistance value according to the DC feeding arrangement and then cause the TE to enter the loop state after making sure that the TE has been held at least 1 minute in quiescent state. When the terminal has been in the loop state for at least

1,2 s, measure the DC current drawn by the TE and the DC voltage across the TE for each of the feed conditions. Allow sufficient setting time, to a maximum of 3 s, to ensure that the measured value is stable

to within $\pm 0,5\%$ for at least 0,2 s. Then repeat the sequence for other measurement points, repeating each time a transition from quiescent state to loop state.

Formal processing: None

Verdict: If the DC voltage/current characteristics are within the limits given in table A.3.1 and shown in figure A.3.1 then Pass; else Fail.

Guidance: Allowing "sufficient setting time" is useful to ensure test repeatability and reproducibility. Nevertheless if the stated stability cannot be found, the setting time shall be limited to 3s. In this latter case a measurement accuracy improvement may be obtained by averaging several measurement readings made during the setting time.

History

Document history		
V1.1.1	October 1997	Membership Approval Procedure MV 9750: 1997-10-14 to 1997-12-12
V1.1.1	January 1998	Publication